

NAVSHIPS 92495

INSTRUCTION BOOK  
*for*  
RF SIGNAL GENERATOR SET  
AN/URM-25F

NEW LONDON INSTRUMENT COMPANY  
NEW LONDON, CONNECTICUT

DEPARTMENT OF THE NAVY  
BUREAU OF SHIPS

*Contract: NObsr 59613*

*Approved by BuShips: 12 MAY 1955*

**LIST OF EFFECTIVE PAGES**

<b>PAGE NUMBERS</b>	<b>CHANGE IN EFFECT</b>	<b>PAGE NUMBERS</b>	<b>CHANGE IN EFFECT</b>
Title page	Original	4-0 to 4-8	Original
A to C	Original	5-1 to 5-2	Original
i to iii	Original	6-1	Original
1-0 to 1-3	Original	7-0 to 7-22	Original
2-0 to 2-18	Original	8-1 to 8-30	Original
3-1	Original	i-1 to i-5	Original



DEPARTMENT OF THE NAVY  
BUREAU OF SHIPS  
WASHINGTON 25, D. C.

IN REPLY REFER TO  
Code 993-100  
12 May 1955

From: Chief, Bureau of Ships  
To: All Activities Concerned with the  
Installation, Operation and Main-  
tenance of the Subject Equipment  
  
Subj: Instruction Book for RF Signal Gen-  
erator Set AN/URM-25F,  
NAVSHIPS 92495

1. This is the instruction book for the subject equipment and is in effect upon receipt.
2. When superseded by a later edition, this publication shall be destroyed.
3. Extracts from this publication may be made to facilitate the preparation of other Department of Defense Publications.
4. All Navy requests for NAVSHIPS Electronics publications should be directed to the nearest District Publications and Printing Office. When changes or revised books are distributed, notice will be included in the Electronics Information Bulletin, NAVSHIPS 900,022(A) and in the Index of Bureau of Ships General and Electronics Publications, NAVSHIPS 250-020.

A. G. MUMMA  
Chief of Bureau



## SIMPLIFIED OPERATING PROCEDURE for RF SIGNAL GENERATOR AN/URM-25F

### CAUTION

Turn SET RF OUTPUT control fully counterclockwise.

### POWER

1. Plug signal generator power plug into 115 volt, 50-1000 cycle source.
2. Operate POWER switch to ON position.
3. Warm-up signal generator for 15 minutes.

### FREQUENCY SELECTION

4. Select frequency range by turning BAND SWITCH to desired range.
5. Tune to exact frequency by rotating TUNING knob. Read frequency directly on calibrated scale. Accuracy will be  $\pm 0.5$  percent.

### CALIBRATION

#### Note

When accuracy greater than  $\pm 0.5$  percent is required, perform steps 6 and 7, otherwise proceed to step 8.

6. Plug high impedance headphones into CAL OUT jack.
7. Calibrate signal generator (on frequencies above 1 megacycle) by turning FUNCTION SWITCH to CAL position and tuning for zero beats. Accuracy at the zero beats will be  $\pm 0.005$  percent.

### OUTPUT VOLTAGE

8. Connect output cable to RF OUT jack. Terminate signal generator into 50 ohms.
9. Set FUNCTION SWITCH to CW position.
10. Turn the MICROVOLTS control fully clockwise.
11. Rotate the SET RF OUTPUT control until the meter pointer reads in the red arc of the meter scale.

12. Select the output voltage range by turning ATTENUATOR knob to desired output voltage.

13. Set exact output voltage by rotating MICROVOLTS control. Read output voltage on the meter scale.

### MODE OF OPERATION

14. Set FUNCTION SWITCH to mode of operation.
15. Reset meter to red arc whenever changing frequency.

### WARNING

Do not reset meter with MICROVOLTS control. Turn MICROVOLTS to MAX and reset with SET RF OUTPUT control.

#### Note

For detailed information on operation, refer to section 4.

#### Note

This Instruction Book is in effect upon receipt. When superseded by a later edition, it shall be destroyed.

Extracts from this publication may be made to facilitate the preparation of other Department of Defense Publications.

All Navy requests for NAVSHIPS Electronics publications should be directed to the nearest District Publications and Printing Office. When changes or revised books are distributed, notice will be included in the Bureau of Ships Journal and in the Index of Bureau of Ships General and Electronics Publications, NAVSHIPS 250-020.

## TABLE OF CONTENTS

<i>Paragraph</i>	<i>Page</i>	<i>Paragraph</i>	<i>Page</i>
<b>SECTION 1—GENERAL DESCRIPTION</b>			
1. Introduction .....	1-1	10. Coupling to Receiver under Test.....	4-5
2. Reference Data .....	1-1	11. Use of Electrical Dummy Load DA-109/ URM-25F .....	4-5
3. Detailed Description .....	1-2	12. Using the Signal Generator .....	4-6
4. Electron Tube Complement .....	1-2	<b>SECTION 5—OPERATOR'S MAINTENANCE</b>	
5. Similarities Between Equipments .....	1-2	1. General .....	5-1
<b>SECTION 2—THEORY OF OPERATION</b>			
1. General Description of Circuits.....	2-0	2. Routine Check Chart .....	5-1
2. RF Oscillator .....	2-3	3. Fuse Replacement .....	5-1
3. Buffer Amplifier .....	2-4	4. Indicator Lamp .....	5-1
4. RF Modulated Amplifier .....	2-4	<b>SECTION 6—PREVENTIVE MAINTENANCE</b>	
5. RF Output .....	2-6	1. Routine Maintenance Check Chart .....	6-1
6. Audio Oscillator .....	2-8	2. Lubrication Data .....	6-1
7. Modulator .....	2-8	<b>SECTION 7—CORRECTIVE MAINTENANCE</b>	
8. Crystal Oscillator .....	2-11	1. Theory of Localization .....	7-1
9. Calibrating Mixer and Amplifier.....	2-12	2. Test Equipment for Trouble Shooting.....	7-1
10. RF and Modulation Metering .....	2-12	3. System Trouble Shooting .....	7-1
11. Power Supply PP-1322/URM-25F.....	2-15	4. Tube Operating Voltages and Currents .....	7-1
12. Impedance Matching Network CU-406/ URM-25F .....	2-17	5. Resistance Measurements .....	7-1
13. Impedance Matching Network CU-408/ URM-25F .....	2-17	6. Interior and Exterior Views of Units.....	7-1
14. Dummy Load DA-109/URM-25F.....	2-17	7. Removing the Signal Generator from the Case .....	7-1
15. Test Lead CX-2919/U .....	2-17	8. Removal of RF Shield Assembly.....	7-2
16. Cord CG-409A/U .....	2-18	9. Removal and Replacement of Parts.....	7-2
<b>SECTION 3—INSTALLATION</b>			
1. Unpacking .....	3-1	10. Disassembly of Step Attenuator.....	7-3
2. Installation .....	3-1	11. Removal of Oscillator Coil Turret.....	7-6
3. Adjustments .....	3-1	12. Removal of Oscillator Transformer Assem- bly .....	7-6
<b>SECTION 4—OPERATION</b>			
1. General .....	4-0	13. Removal of Tuning Capacitor .....	7-7
2. Power Circuit .....	4-0	14. Replacing RF Oscillator Circuit Compo- nents .....	7-7
3. Setting Carrier Frequency .....	4-0	15. Readjustment of Frequency Calibration.....	7-7
4. Crystal-Controlled Output .....	4-2	16. RF Oscillator Calibration Procedure.....	7-8
5. Crystal Calibration .....	4-2	17. Removal of Bridge Assembly.....	7-9
6. Adjusting Output Voltage .....	4-3	18. RF Metering Calibration .....	7-9
7. Internal Modulation and Audio Output.....	4-4	19. Percent Modulation Meter Calibration.....	7-10
8. External Modulation .....	4-4	20. RF Step Attenuator Tests.....	7-10
9. Terminating the Signal Generator.....	4-4	21. Crystal Oscillator Calibration .....	7-13
		22. Dial Scale Lamp Replacement.....	7-13
		<b>SECTION 8—PARTS LIST</b>	

## LIST OF ILLUSTRATIONS

<i>Figure</i>	<i>Title</i>	<i>Page</i>	<i>Figure</i>	<i>Title</i>	<i>Page</i>
<b>SECTION 1—GENERAL DESCRIPTION</b>					
1-1	RF Signal Generator Set AN/URM-25F Complete Equipment with Accessories	1-0	2-3	Buffer Amplifier Simplified Schematic..	2-4
<b>SECTION 2—THEORY OF OPERATION</b>					
2-1	RF Signal Generator AN/URM-25F Functional Block Diagram.....	2-1, 2-2	2-4	RF Modulated Amplifier Simplified Schematic .....	2-5
2-2	RF Oscillator Simplified Schematic.....	2-3	2-5	RF Modulator Amplifier Waveforms Van der Bijl Modulation .....	2-6
			2-6	RF Output Step Attenuator Simplified Schematic .....	2-7

**LIST OF ILLUSTRATIONS (Cont'd)**

<i>Figure</i>	<i>Title</i>	<i>Page</i>	<i>Figure</i>	<i>Title</i>	<i>Page</i>
2-7	Wien Bridge Audio Oscillator Simplified Schematic .....	2-9, 2-10	<b>SECTION 4—OPERATION</b>		
2-8	Modulator, External Modulation Simplified Schematic .....	2-11	4-1	RF Signal Generator AN/URM-25F Front Panel .....	4-0
2-9	Modulator, Internal Modulation Simplified Schematic .....	2-11	4-2	Frequency, Index and Vernier Scales.....	4-3
2-10	Crystal Oscillator Simplified Schematic .....	2-12	4-3	Dummy Load Impedance Curve.....	4-6
2-11	Calibrating Mixer and Amplifier Simplified Schematic .....	2-13, 2-14	<b>SECTION 7—CORRECTIVE MAINTENANCE</b>		
2-12	Modulation Metering Simplified Schematic .....	2-15	7-1	Failure Reports .....	7-0
2-13	RF Metering Simplified Schematic.....	2-15	7-2	RF Signal Generator AN/URM-25F Front Panel .....	7-2
2-14	Power Supply PP-1322/URM-25F Simplified Schematic .....	2-16	7-3	RF Shield Assembly .....	7-3
2-15	Impedance Matching Unit CU-406/URM-25F Simplified Schematic .....	2-17	7-4	Attenuator, Exploded View .....	7-4
2-16	Impedance Matching Network CU-408/URM-25F Simplified Schematic .....	2-17	7-5	Oscillator Coil Turret .....	7-5
2-17	Electrical Dummy Load DA-109/URM-25F Simplified Schematic .....	2-17	7-6	Bridge Assembly Components .....	7-6
2-18	Test Lead CX-2919/U Simplified Schematic .....	2-18	7-7	Bridge Assembly Components .....	7-8
<b>SECTION 3—INSTALLATION</b>			7-8	Bridge Assembly Components .....	7-10
3-1	RF Signal Generator AN/URM-25F Packaging Diagram .....	3-1	7-9	Bridge Assembly Components .....	7-11
			7-10	Bridge Assembly Components .....	7-12
			7-11	Percentage Modulation Chart .....	7-12
			7-12	Power Supply PP-1322/URM-25F.....	7-13
			7-13	Cover, Signal Generator CW-346/URM-25F Accessory Units Mounted..	7-14
			7-14	RF Signal Generator AN/URM-25F Schematic Diagram .....	7-23, 7-24

**LIST OF TABLES**

<i>Table</i>	<i>Title</i>	<i>Page</i>	<i>Table</i>	<i>Title</i>	<i>Page</i>
<b>SECTION 1—GENERAL DESCRIPTION</b>			<b>SECTION 6—PREVENTIVE MAINTENANCE</b>		
1-1	Equipment Supplied .....	1-2	6-1	Lubrication Data .....	6-1
1-2	Shipping Data .....	1-2	<b>SECTION 7—CORRECTIVE MAINTENANCE</b>		
1-3	Electron Tube Complement .....	1-2	7-1	Frequency Calibration Data .....	7-14
1-4	Basic Differences in AN/URM-25 Series Equipments .....	1-3	7-2	Trouble Symptom Chart .....	7-15
<b>SECTION 2—THEORY OF OPERATION</b>			7-3	Trouble Localization Chart .....	7-16
2-1	Band Switch Frequency Ranges .....	2-18	7-4	Specific Trouble Test Chart .....	7-17
2-2	Component Values, Oscillator Transformer Assemblies .....	2-18	7-5	Tube Operating Voltages and Currents .....	7-20
<b>SECTION 4—OPERATION</b>			7-6	Resistance Measurements .....	7-21
4-1	Function of Front Panel Controls .....	4-1	7-7	Rated Tube Characteristics .....	7-22
4-2	Frequency Interpolation Procedure .....	4-2	<b>SECTION 8—PARTS LIST</b>		
4-3	RF Attenuator Calibrations .....	4-4	8-1	List of Major Units .....	8-1
4-4	Termination References .....	4-5	8-2	Table of Replaceable Parts .....	8-2
4-5	Termination Methods .....	4-7	8-3	Cross Reference Parts List .....	8-29
<b>SECTION 5—OPERATOR'S MAINTENANCE</b>			8-4	List of Manufacturers .....	8-30
5-1	Routine Check Chart .....	5-1	8-5	Applicable Color Codes and Miscellaneous Data .....	8-31
5-2	Symptoms of Fuse Failure .....	5-2			
5-3	Fuse Locations .....	5-2			

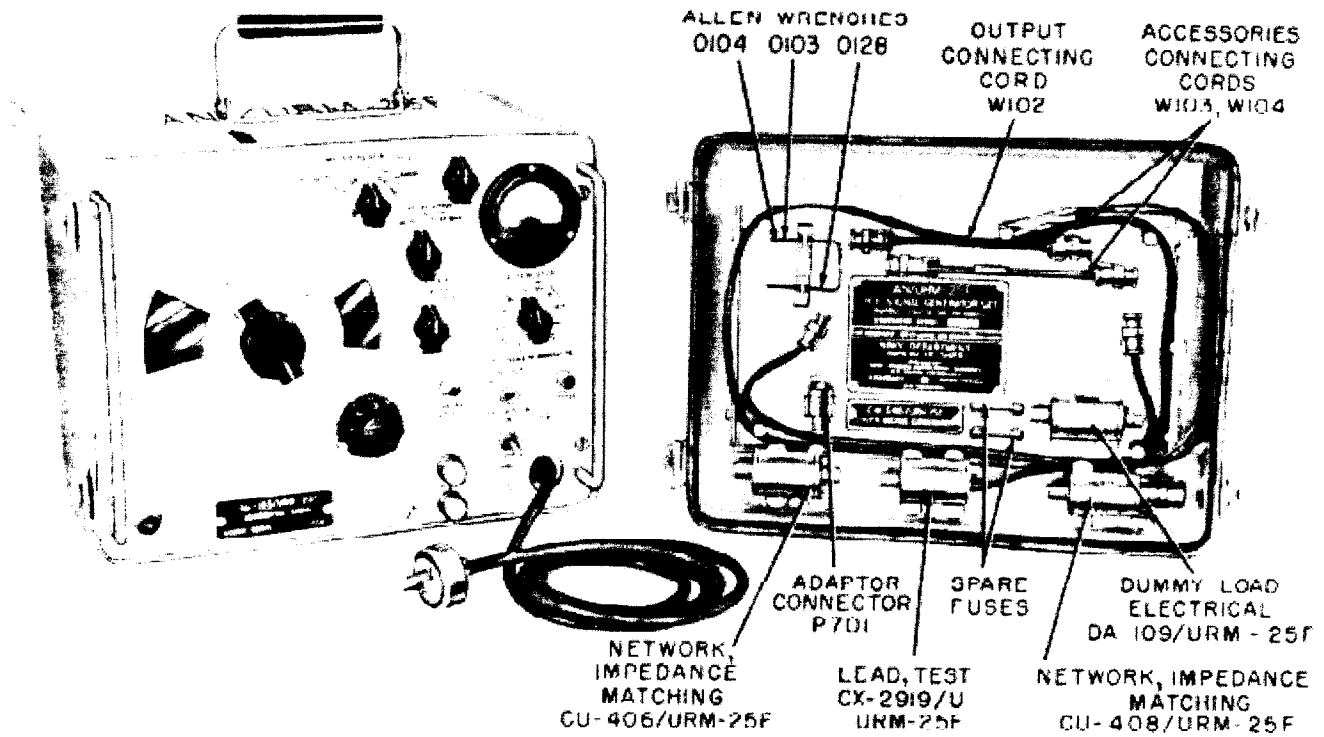

Figure 1-1. RF Signal Generator Set AN/URM-25F Complete Equipment with Accessories



## SECTION 1 GENERAL DESCRIPTION

### 1. INTRODUCTION.

*a.* RF Signal Generator AN/URM-25F is a test equipment for generating radio frequency signals, either modulated or unmodulated, over a continuous range of frequencies from 10 kilocycles to 50 megacycles.

*b.* All units, including the power supply, are incorporated in a single portable cabinet (see figure 1-1). The units supplied and their weights are listed in Table 1-1.

*c.* The AN/URM-25F operates from a 105- to 130-volt, 50- to 1000-cycle, single-phase supply. The equipment is well shielded, ruggedly built and with the cover in place capable of withstanding submersion. A calibrated main tuning dial accurate to 0.5 percent provides coarse setting of the output frequency. Precise adjustment of frequency, to within  $\pm 0.05$  percent above 15 megacycles, can be obtained by the use of the built-in crystal calibrator. The frequency at the crystal check points is within 0.005 percent at normal room temperature. A front panel meter indicates the percentage of modulation and RF output. The amplitude of the RF output signal is controlled by a calibrated attenuator.

*d.* The complete equipment consists of the following units:

- (1) Generator, Signal.....SG-103/URM-25F
- (2) Power Supply .....PP-1322/URM-25F
- (3) Cover, Signal Generator.CW-346/URM-25F
- (4) Network, Impedance Matching  
CU-408/URM-25F
- (5) Dummy Load, Electrical.DA-109/URM-25F
- (6) Network, Impedance Matching  
CU-406/URM-25F
- (7) Lead, Test .....CX-2919/U
- (8) Cord (1) CG-409A/U .....(4'2")
- (9) Cord (2) CG-409A/U .....(6")

### 2. REFERENCE DATA.

*a.* Nomenclature—RF Signal Generator Set AN/URM-25F.

*b.* Contract—NObsr 59613.

*c.* Contractor—New London Instrument Company, Box 189, New London, Connecticut.

*d.* Cognizant Naval Inspector. Inspector of Naval Materiel, Bridgeport, Connecticut.

*e.* Number of Packages Involved per Complete Shipment—two packages, consisting of one equipment and one equipment spares.

*f.* Total Cubical Contents—see Table 1-1.

*g.* Total Weight—see Table 1-1.

*b.* Frequency Range—10 kilocycles to 1 megacycle  $\pm 0.5$  percent; 1 megacycle to 50 megacycles  $\pm 0.05$  percent.

*i.* Tuning Bands and Range of each Band.

- (1) Band 1—10 to 26 KC
- (2) Band 2—26 to 75 KC
- (3) Band 3—75 to 220 KC
- (4) Band 4—220 to 600 KC
- (5) Band 5—0.6 to 1.5 MC
- (6) Band 6—1.5 to 3.8 MC
- (7) Band 7—3.8 to 10 MC
- (8) Band 8—10 to 25 MC
- (9) Band 9—25 to 50 MC

*j.* Types of Modulation—

(1) Amplitude Modulation—0 to 50 percent (indicated accuracy within  $\pm 10$  percent).

(2) Internal Modulation Frequencies.

(a) 400 cycles per second  $\pm 5$  percent.

(b) 1000 cycles per second  $\pm 5$  percent.

(3) External Modulation Frequency—100 to 15,000 cycles per second on all RF carrier frequencies above 300 kilocycles. Below 300 kilocycles with modulation frequencies up to 1000 cycles.

*k.* Output Voltage (RF)

(1) 0.1 to 100,000 microvolts ( $\pm 10\%$ ) continuously variable (across a 50-ohm termination impedance).

(2) Approximately 2 volts adjustable (across a high impedance) open circuit.

*l.* Output Voltage (AF)

(1) Frequency—400 or 1000 cycles per second.

(2) Voltage—0 to 6 volts, adjustable; (across 100,000 ohms).

(3) Adjustment—voltage varied by front panel control.

(4) Voltage Calibration—Proportional to reading on modulation meter.

*m.* Output Impedance

(1) 50 ohms at RF OUTPUT jack (J102).

(2) 500 ohms at HIGH RF OUTPUT jack (J101).

(3) 50,000 ohms at AUDIO OUT jack (J104).

*n.* Power Supply

(1) Power source requirements—115 volts  $\pm 10$  percent, 50 to 1000 cycle, single phase.

(2) Power consumption—55 watts.

**3. DETAILED DESCRIPTION.**

a. The frequency range of the AN/URM-25F is 10 kilocycles to 50 megacycles per second. These frequencies are covered by a single tube oscillator in nine bands by a band selector switch located on the front panel. Within each band the frequency is varied by means of a variable tuning capacitor. The frequency generated can be read directly to .5 percent from the main frequency dial which is geared to tuning capacitor.

b. The RF output is continuously variable from 0.1 to 100,000 microvolts and is indicated by a meter reading in association with the calibrated step attenuator. A high output is also available and will provide up to a 2-volt signal.

c. The RF output may be modulated or unmodulated. An internal modulator of either 400 or 1000 cycles is provided. Modulation can be varied from 0 to 50 percent. Provision for external modulation is available.

d. A built-in 1-megacycle crystal calibrator, effective between 1 megacycles to 50 megacycles, is used for

frequency calibration. The frequency accuracy of the signal generator is within  $\pm .05$  (above 15 mc) percent when aligned with the crystal calibrator. At calibration points accuracy is .005 percent at normal room temperature.

e. A 400- or 1000-cycle audio signal is available at the AUDIO OUT jack. This signal can be varied from 0 to approximately 6.0 volts by the % MOD control. The audio signal amplitude is proportional to the modulation percent reading on the front panel meter. A complete description of operation is given in section 4.

**4. ELECTRON TUBE COMPLEMENT.**

The quantities and types of electron tubes used in the AN/URM-25F are listed in Table 1-3.

**5. SIMILARITIES BETWEEN EQUIPMENTS.**

a. The AN/URM-25F though similar in operation to previous models, incorporates basically different mechanical and electrical designs.

b. The frequency range 10 to 50,000 kilocycles is divided differently (see Table 2-1).

**TABLE 1-1. EQUIPMENT SUPPLIED**

QUANTITY PER SHIPMENT	TITLE OF UNIT	NAVY TYPE OR A-N DESIGNATION	OVERALL DIMENSIONS (INCHES)			VOLUME (CU. IN.)	WEIGHT (LBS.)
			LENGTH	HEIGHT	DEPTH		
1	Generator, Signal	SG-103/URM-25F	14-3/4	11-1/4	11-1/8	1886	35
1	Cover, Signal Generator	CW-346/URM-25F					
1	Network, Impedance Matching	CU-406/URM-25F					
1	Network, Impedance Matching	CU-408/URM-25F					
1	Dummy Load, Electrical	DA-109/URM-25F					
1	Lead, Test	CX-2919/U					
1	Cord	CG-409 A/U (4'2")					
2	Cord	CG-409 A/U (6")					

**TABLE 1-2. SHIPPING DATA**

NUMBER OF BOXES	CONTENTS		OVERALL DIMENSIONS (INCHES)			VOLUME (CU. IN.)	WEIGHT (LBS.)
	NAME	DESIGNATION	LENGTH	HEIGHT	DEPTH		
1	RF Signal Generator Set	AN/URM-25F	19	14-1/2	14-1/2	3995	45
1	Equipment Maintenance Parts	AN/URM-25F	12	6	8	576	—

**TABLE 1-3. ELECTRON TUBE COMPLEMENT**

QUANTITY	TUBE TYPE	SYMBOL DESIGNATION	FUNCTION	LOCATION
1	6AH6	V101	RF osc.	Signal generator chassis
1	6AH6	V102	Buffer	Signal generator chassis
1	6AG7Y	V103	Modulated RF amp.	Signal generator chassis

TABLE 1-3. ELECTRON TUBE COMPLEMENT (Cont'd)

QUANTITY	TUBE TYPE	SYMBOL DESIGNATION	FUNCTION	LOCATION
1	6AH6	V104	Audio oscillator or calibrating amp.	Signal generator chassis
1	6AH6	V105	Audio oscillator or calibrating amp.	Signal generator chassis
1	6AH6	V106	Modulator or crystal oscillator	Signal generator chassis
1	6X4W	V107	Rectifier	Power supply compartment
1	0A3	V108	Voltage regulator	Power supply compartment
1	IN145	CR101	RF meter diode	Signal generator chassis
1	IN69	CR102	Calibrator mixer diode	Signal generator chassis
1	IN69	CR103	Modulation meter diode	Signal generator chassis

TABLE 1-4. BASIC DIFFERENCES IN AN/URM-25 SERIES EQUIPMENTS

MODEL	LINE CORD	"EXT MOD IN" FILTER	FREQUENCY SCALE LAMP FILTER	CRYSTAL CALIBRATOR	RF PEAKING COIL	POWER SUPPLY PP-562/URM-25	OTHER ITEM DIFFERENCES
AN/URM-25	Cord-Filter CX-1595 URM-25	Single section unshielded	None	None	One peaking coil for Band H (L-114)	L-201, T-201, Non JAN types	
AN/URM-25A	Line Cord Symbol Number W-101	Triple section shielded	Triple section shielded	None	One peaking coil for Band H (L-114)	RF bypasses C-205, C-206, added; L-201, T-201, JAN types	RF bypasses C-147, C-148 added to line filter
AN/URM-25B	Line Cord Symbol Number W-101	Triple section shielded in addition to an unshielded choke	Triple section shielded	V-108 (6BE6) crystal calibrator	Two peaking coils (L-121, L-122), effective from 16 mc to 50 mc	RF bypasses C-205, C-206, added; L-201, T-201, JAN types	C-108 (.5 uf) removed adapter connector UG-684/U added, C-149, C-156, E-131 and C-118 added, C-113 changed from 10,000 uuf to 6200 uuf, other wiring changes
AN/URM-25C	Line Cord Symbol Number W-101	Triple section shielded in addition to an unshielded choke	Triple section shielded	V-108 (6BE6) crystal calibrator	Two peaking coils (L-121, L-122), effective from 16 mc to 50 mc	RF bypasses C-205, C-206, added; L-201, T-201, JAN types	6J4 (Buffer Amplifier) replaced by two 6AH6; 9004 (RF diode) replaced by IN34 germanium diode; other circuit and component changes as required for above
AN/URM-25D	AC Line Cable Assembly CX-2647/U (6' 5/8")	Single "L" section LC filter	None	V-105 (5750) crystal calibrator	Pass band accomplished with M-derived filter	Voltage Stabilizer changed to V-108 (0A2); R-201 is 3100 ohms, 12.5 watts	Entire tube complement (See table 1-4), and associated circuitry differs from preceding models
AN/URM-25F	Attached Line Cord Symbol Number W-101	Single section RC filter	None	V-106 (6AH6)	Pass band accomplished with M-derived filter	Voltage Stabilizer changed to V-602 (0A3)	Entire tube complement (See table 1-4), and associated circuitry differs from preceding models

## SECTION 2 THEORY OF OPERATION

### 1. GENERAL DESCRIPTION OF CIRCUITS.

(See figure 2-1.)

a. Signal Generator AN/URM-25F is an eight-tube instrument capable of producing accurate test signals used in the servicing of radio receivers. The functional principle of the signal generator is similar to a radio-frequency transmitter. A single stage vacuum tube oscillator generates an RF signal in the range from 10 kilocycles to 50 megacycles. This wide range is covered in nine bands by a set of turret-mounted oscillator coils. An untuned buffer-amplifier isolates the oscillator and strengthens the RF signal. A gain control (MICROVOLTS) between the buffer-amplifier and RF output stage permits fine control of the signal amplitude. The RF output tube, also untuned, amplifies the RF signal and couples it to a precision 12-position RF step attenuator. This attenuator provides coarse adjustment of the output signal. A HIGH RF OUTPUT jack, located ahead of the attenuator, supplies a high level RF signal. The RF signal may be internally or externally modulated from 0 to 80 percent, with 0 to 50 percent modulation indicated on the front panel meter to an accuracy of 10 percent. A built-in Wien-bridge oscillator generates a sine wave audio signal of either 400 to 1000 cycles. The amplitude of this signal is varied by the % MOD control. The arm of the % MOD control is coupled to the modulator tube. The modulator operates as a cathode follower and grid-modulates the RF output stage. The audio signals are also available for external use. Two metering circuits measure and monitor the radio and audio frequency signals. Measurements appear on a calibrated front panel meter. A 1-MC crystal calibrator is incorporated to insure accurate RF output signals. When calibrated against the crystal calibrator, the generator accuracy will be within 0.005 percent at the calibration points. The crystal calibrator operates only on frequencies above 1 megacycle. A self-contained calibrating amplifier amplifies beat signals to provide sufficient amplitude to drive a pair of high impedance earphones. A five-position function switch sets the mode of operation:

Position 1 CAL	Energizes the crystal calibrating oscillator and calibrating head-phone amplifier.
Position 2 CW	Produces an unmodulated RF carrier signal.

Position 3 EXT MOD	Permits external modulation of the RF carrier signal.
Position 4 INT MOD 400 cycle	Internally modulates the RF carrier with a 400-cycle sine wave signal. Provides a 400-cycle audio signal for external use.
Position 5 INT MOD 1000 cycle	Internally modulates the RF carrier with a 1000-cycle sine wave signal. Provides a 1000-cycle audio signal for external use.

The instrument operates on 115-volt, 50- to 1000-cycle power. A transformer-isolated power supply incorporates a full-wave vacuum tube rectifier and a regulator tube to supply DC power at +150 and +75 volts. The +75-volt output is regulated and powers the RF oscillator. The unregulated +150-volt output supplies plate power to all other stages. A 6.4-volt winding energizes the vacuum tube heaters and dial lamps.

A set of test leads, impedance matching networks and dummy load unit, provide the necessary connections for connecting Signal Generator AN/URM-25F to equipment under test. The test leads and other terminating units are contained and carried in the front cover.

b. The various stages in the block diagram will now be discussed individually in this section under the following paragraphs:

1. RF Oscillator	Par. 2
2. Buffer-Amplifier	Par. 3
3. RF Modulated Amplifier	Par. 4
4. RF Output	Par. 5
5. Audio Oscillator	Par. 6
6. Modulator	Par. 7
7. Crystal Oscillator	Par. 8
8. Calibrating Amplifier	Par. 9
9. RF and Modulation Metering	Par. 10
10. Power Supply	Par. 11
11. Impedance Matching Network CU-406/URM-25F	Par. 12
12. Impedance Matching Network CU-408/URM-25F	Par. 13
13. Electrical Dummy Load DA-109/URM-25F	Par. 14
14. Test Lead CX-2919/U	Par. 15
15. Cord CG-409A/U 3 pieces	Par. 16

NAVSHIPS 92495

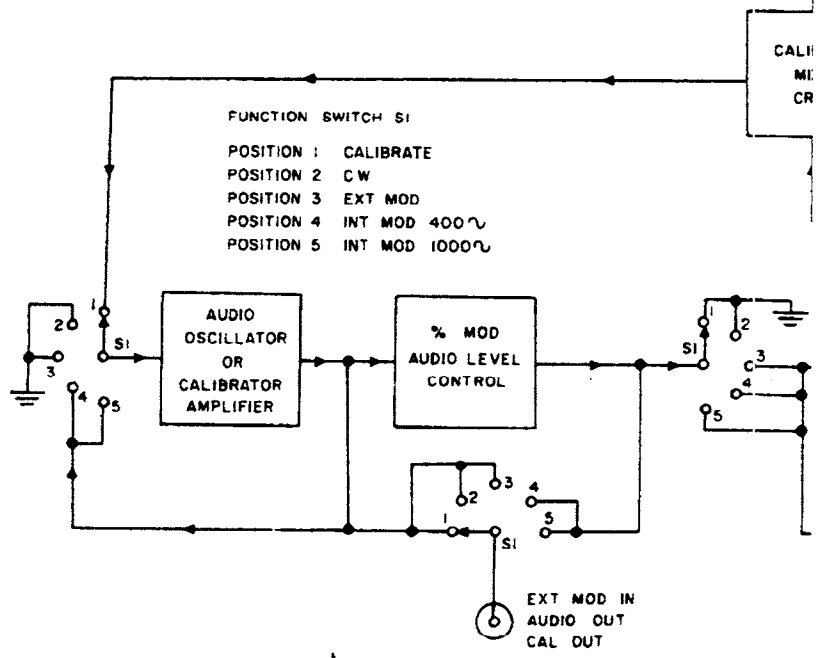
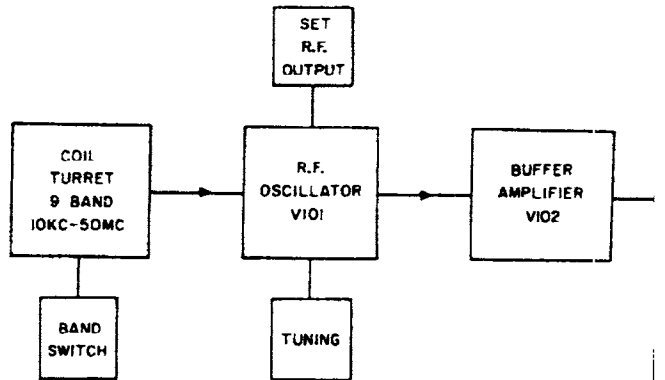

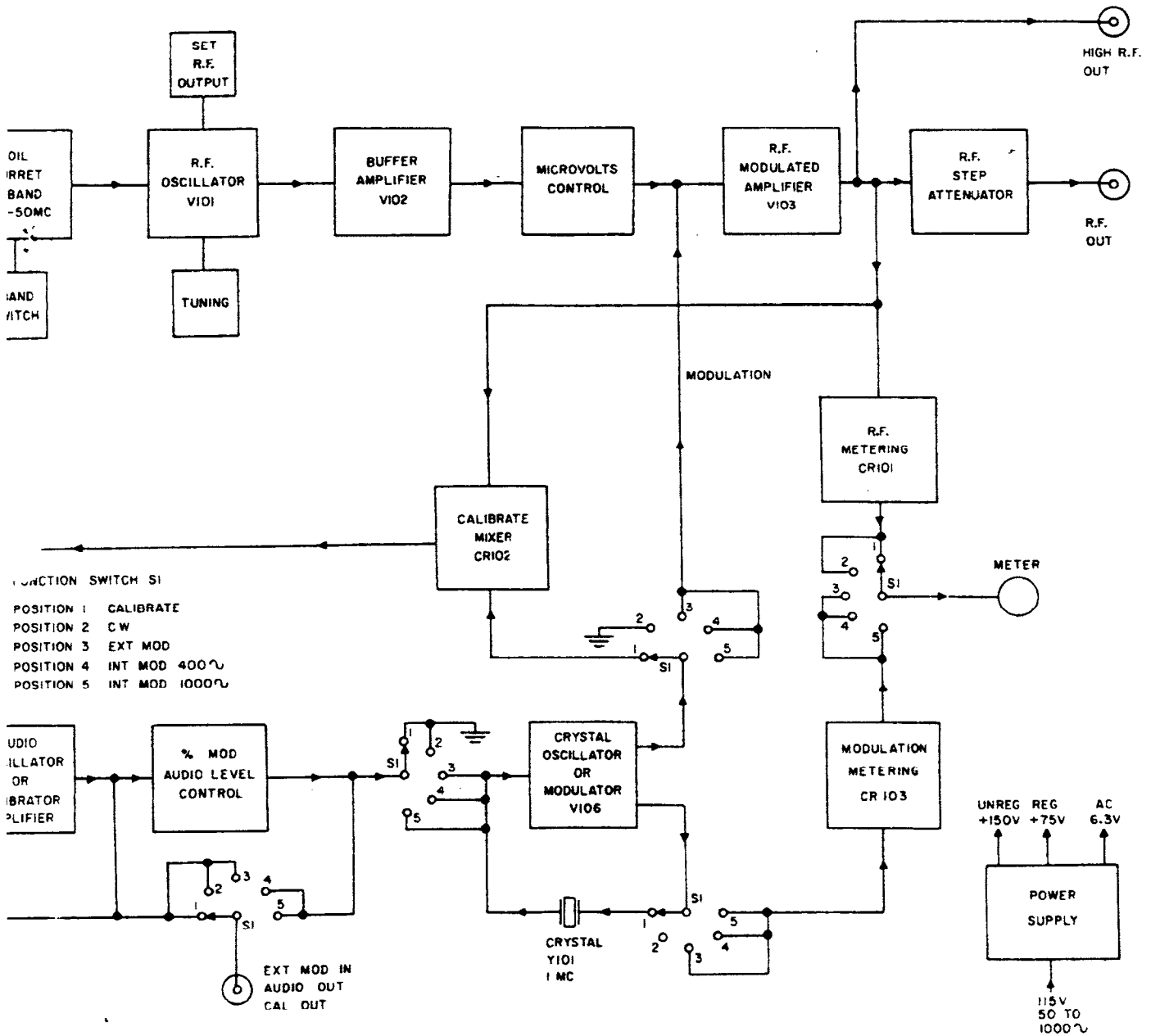

Figure 2-1. RF Signal Generator AN/URM-25F  
Functional Block Diagram

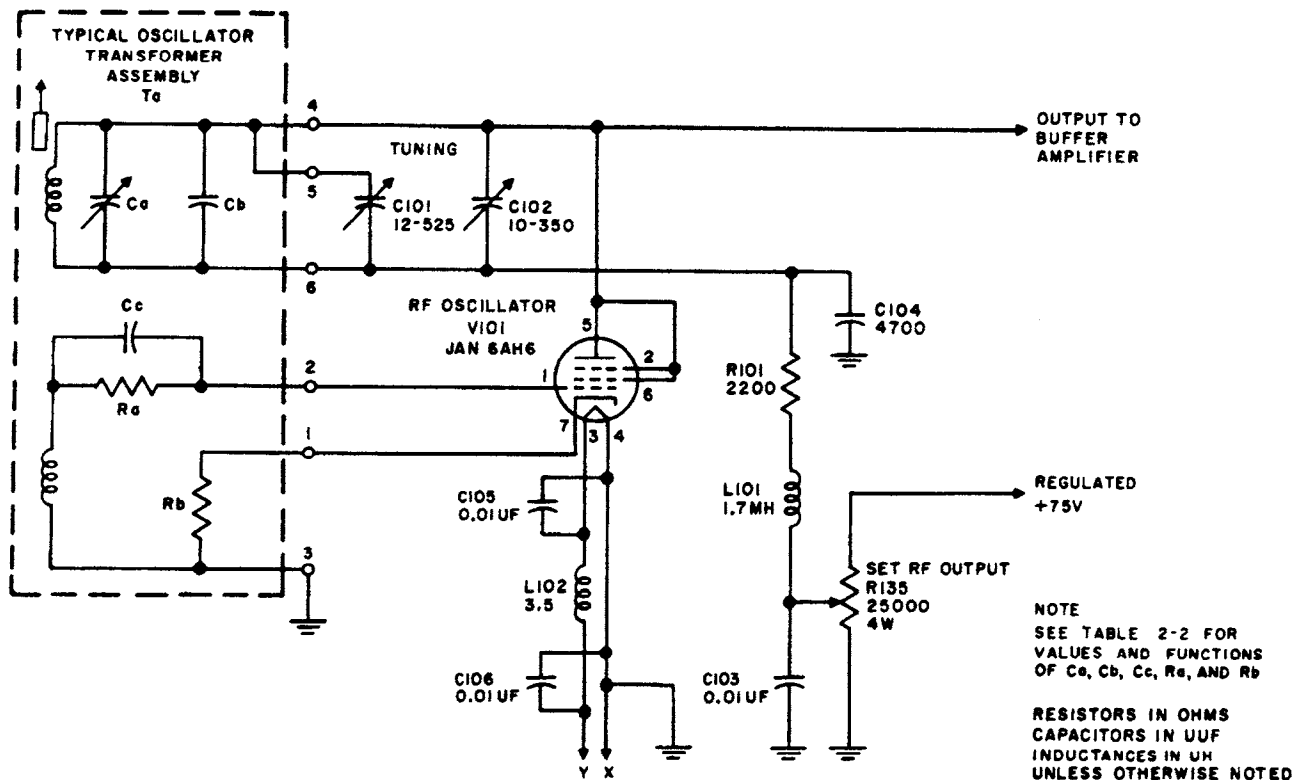

Figure 2-2. RF Oscillator Simplified Schematic

2. RF OSCILLATOR. (See figure 2-2.)

a. The RF oscillator generates the carrier signal. Its major components consist of an oscillator tube, oscillator transformer assemblies, a tuning capacitor and a SET RF OUTPUT control.

b. The oscillator circuit operates as a tuned-plate type. Positive feedback to sustain oscillation is provided by the secondary winding of oscillator transformer Ta. A single triode-connected 6AH6 vacuum tube generates the carrier signal on all bands. The frequency range of 10 kilocycles to 50 megacycles is covered in nine bands with a separate transformer assembly for each band. The frequency ranges of the nine bands are shown in Table 2-1. The oscillator transformer assemblies are turret-mounted and are positioned by the front panel BAND SWITCH. One assembly is connected at a time. Spring contacts automatically make the necessary connections for operation. Each assembly contains an oscillator transformer, a trimmer, a temperature compensating capacitor, a grid-leak capacitor, and cathode and grid-leak resistors. The oscillator coil has separate grid and plate windings with a powdered iron slug to vary the transformer primary inductance. A two-section variable tuning capacitor tunes the plate winding and varies the oscillator frequency between the limits of each band. On bands 5 to 9, 0.6 megacycles to 50 megacycles, one section of the tuning capacitor is disconnected since less capacity is needed to cover the frequency range.

c. Two calibrating adjustments are supplied on each transformer assembly. A slug, in the plate winding, sets the low frequency calibration and a trimmer capacitor Ca across the winding permits high frequency calibration. A temperature compensation capacitor Cb shunts the plate winding and eliminates drift due to temperature changes. Cathode resistor Rb is switched into the circuit on the low frequency bands (10 kilocycles to 1.5 megacycles) to increase the oscillator stability and improve the waveshape. This resistor is not necessary above 1.5 megacycles.

d. Plate supply voltage for the oscillator tube is set by SET RF OUTPUT control R135. This front panel adjustment varies the amplitude of the RF oscillator signal. The use of the SET RF OUTPUT control is covered in paragraph 5, "RF Output." This control, a wire-wound potentiometer connected across a VR tube (see "Power Supply," paragraph 11), sets the plate supply to a maximum of 75 volts.

e. RF choke coil L101 in the plate circuit prevents RF leakage into the B supply wiring. Capacitors C103 and C104 bypass RF currents and prevent them from entering the power supply wiring. To eliminate oscillator leakage through the heater-cathode capacity, RF filter components C105, C106, L102 are incorporated. This network bypasses leakage currents to ground.

f. The carrier signal is taken from the plate of the oscillator tube and coupled to the buffer amplifier. Refer to paragraph 3, "Buffer Amplifier" for details of operation.

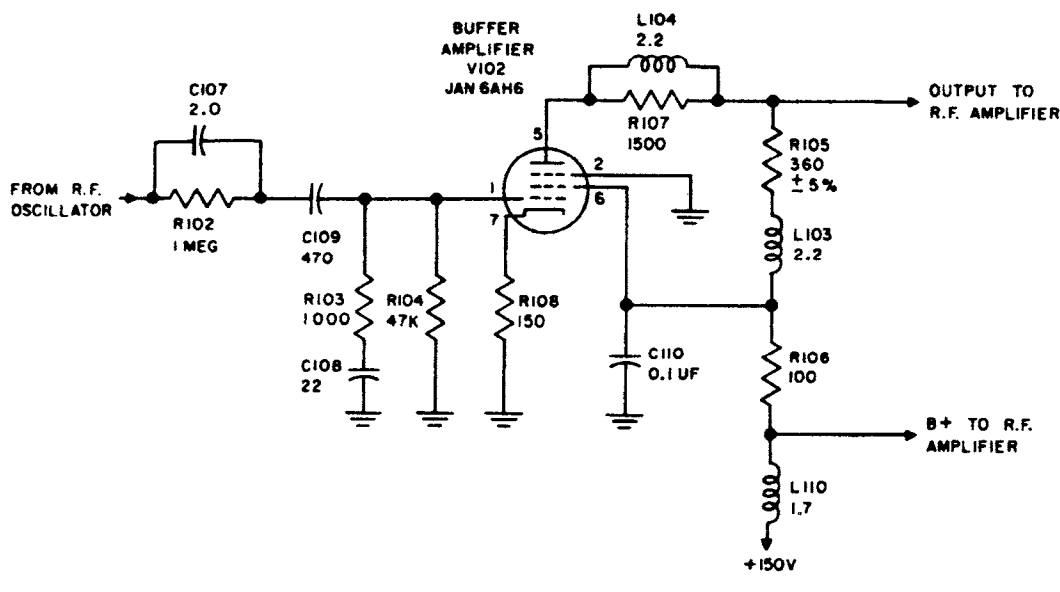

NOTE  
RESISTORS IN OHMS  
CAPACITORS IN UUF  
INDUCTANCES IN UH  
UNLESS OTHERWISE NOTED

Figure 2-3. Buffer Amplifier Simplified Schematic

3. BUFFER AMPLIFIER. (See figure 2-3a)

a. Buffer amplifier V102 is an untuned amplifier located between the RF oscillator and RF output amplifier. It consists of a pentode-connected 6AH6 vacuum tube and its associated components. As a buffer, it isolates the oscillator and prevents variations in loading from affecting the oscillator frequency. As an amplifier it amplifies the oscillator output approximately 1.5 times.

b. The buffer amplifier obtains its input signal from the RF oscillator through a coupling and equalizing network consisting of C107, C108, C109, R102, R103, and R104. This network equalizes for losses due to wiring, stray, and tube capacities. Unbypassed cathode resistor R108 provides bias for the tube and supplies feedback to stabilize the stage gain and reduce carrier distortion.

c. The plate circuit contains shunt and series peaking coils L103 and L104 and a low value of plate load resistance R106. These components extend the frequency response of the stage to 50 megacycles.

d. The output signal is picked off at the junction of L104 and R105 and coupled to the RF amplifier. A detailed description of the RF modulated amplifier is given in paragraph 4.

4. RF MODULATED AMPLIFIER.

(See figures 2-4 and 2-5.)

a. RF modulated amplifier V103 follows the buffer amplifier and functions as the output stage of the signal generator. It consists of a 6AG7Y tube operating as a single-stage class A pentode amplifier. Modulation of the RF carrier is produced in this stage.

b. The RF carrier signal is coupled to the grid of the RF modulated amplifier through blocking capacitor C111, gain control R109 (MICROVOLTS), and series

peaking coil L105, and its damping resistor R110. The MICROVOLTS control permits fine adjustment of output amplitude. Series peaking coils, which compensate for losses due to stray wiring and tube capacities, boost the RF signal on the higher bands. Modulation frequencies are applied via R112. (See paragraph 7.)

c. A Van der Bijl class A modulated amplifier circuit produces the modulated RF carrier. This type of modulator utilizes the principle that the amplification of a pentode depends upon the bias of the stage. The carrier and the modulating signal are mixed at the control grid of V103 as shown in figure 2-4. Since the carrier is small, it cannot swing sufficiently to affect the stage bias. The large modulating signal, however, exerts a great deal of control over the bias. Therefore amplification of the carrier is varied at an audio rate producing modulation. The plate current contains both the modulating frequency (see figure 2-5) and the modulated carrier. Only the latter component is desired. Hence, the modulating frequency is removed by a bandpass filter in the plate circuit of the amplifier. This filter is described in paragraphs e and f of this section. The correct no-signal bias for V103 is provided by cathode resistor R113. Capacitors C113 and C114 bypass RF and audio currents around R113 to ground.

d. B plus is shunt fed to the plate circuit of the RF modulated amplifier by L107 and L108. Peaking coils L106 and L109 and the tube and stray capacities form a series compensation network. This network extends the frequency response of the RF modulated amplifier to 50 megacycles and couples it to the step attenuator. (See paragraph 5.) C118 is a blocking capacitor. The RF metering and high RF output are picked off at the beginning of the attenuator network which is the junction of L109 and R118.



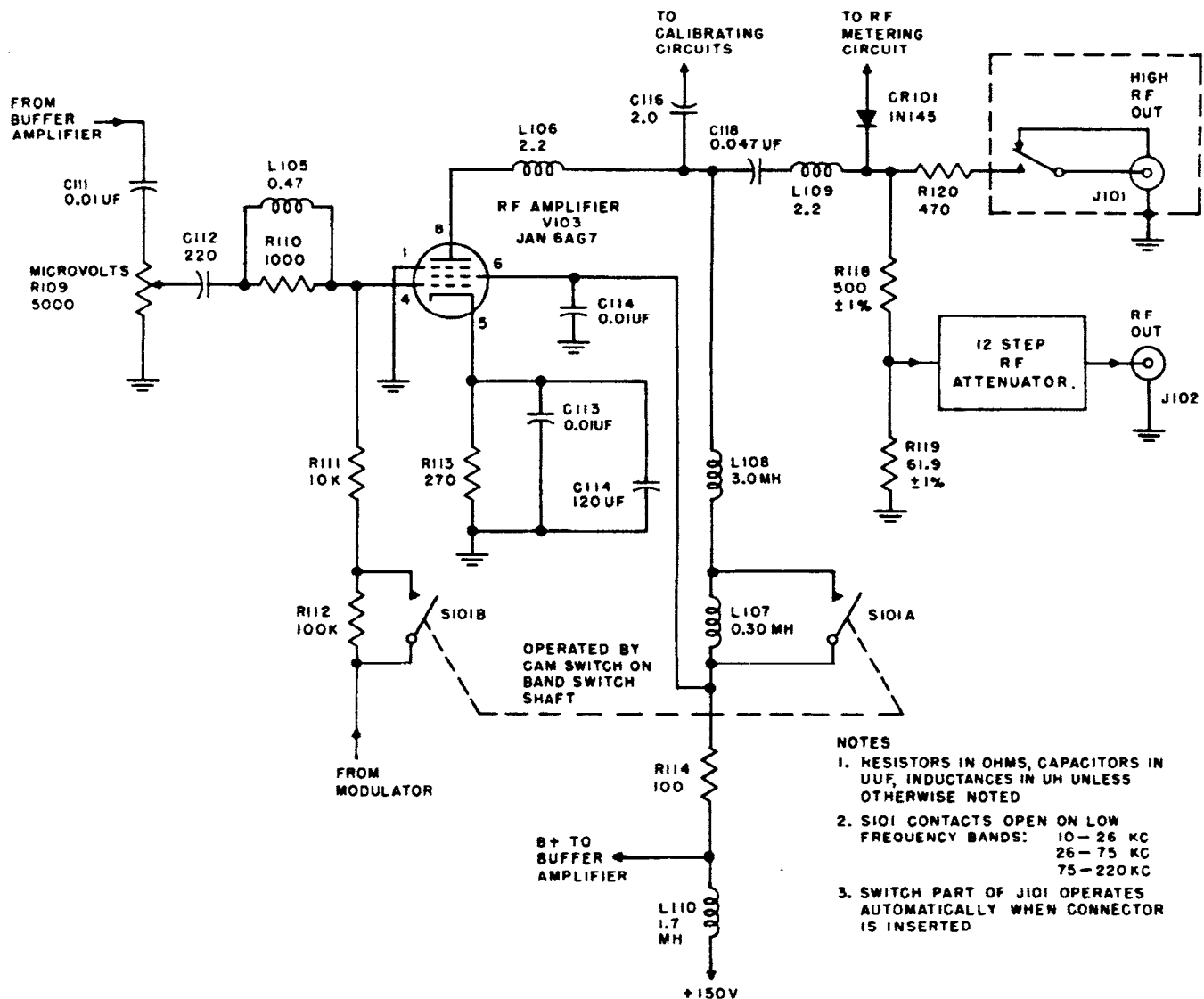

Figure 2-4. RF Modulated Amplifier Simplified Schematic

e. To prevent audio modulation signals from being bypassed to ground by the low value of R109, a small value of capacitance (C112) is employed in the arm of the MICROVOLTS control. This capacitor offers a high impedance to audio signals, but low opposition to RF signals and thereby allows both RF and audio signals to appear simultaneously at the grid of V103.

f. The RF carrier frequencies extend down to 10 kilocycles. The modulating frequencies extend up to 15,000 cycles. Switch S101 prevents the overlapping of these frequencies by restricting the modulating frequencies to less than 1000 cycles on carrier frequencies below 300 kilocycles. Switch S101 is operated automatically by a cam on the bandswitch shaft. The switch opens on bands 1, 2, and 3 (10 kilocycles to 220 kilocycles) and closes on bands 4 to 9 (220 kilocycles to 50 megacycles).

g. When switch S101 is closed, L107 is shorted out; L108, C118, and R119 act as a high pass filter, attenuating frequencies below 100 kilocycles. The filter removes the modulating audio frequencies in the output, leaving only the modulated RF signal to appear at the attenuator. Resistor R112 is shorted out, leaving an effective grid circuit resistance of 10,000 ohms. This allows modulation frequencies of up to 15,000 cycles to appear at the grid of V103.

h. When switch S101 is open, L107 is in the plate circuit, and the resulting high pass filter formed by L107 and L108 in series with C118, R118 and R119 removes frequencies below 8 kilocycles. This allows the modulated RF frequencies down to 10 kilocycles to appear at the output, while the audio modulation frequencies are removed. Resistor R112 is in the grid circuit of the RF modulated amplifier resulting in an

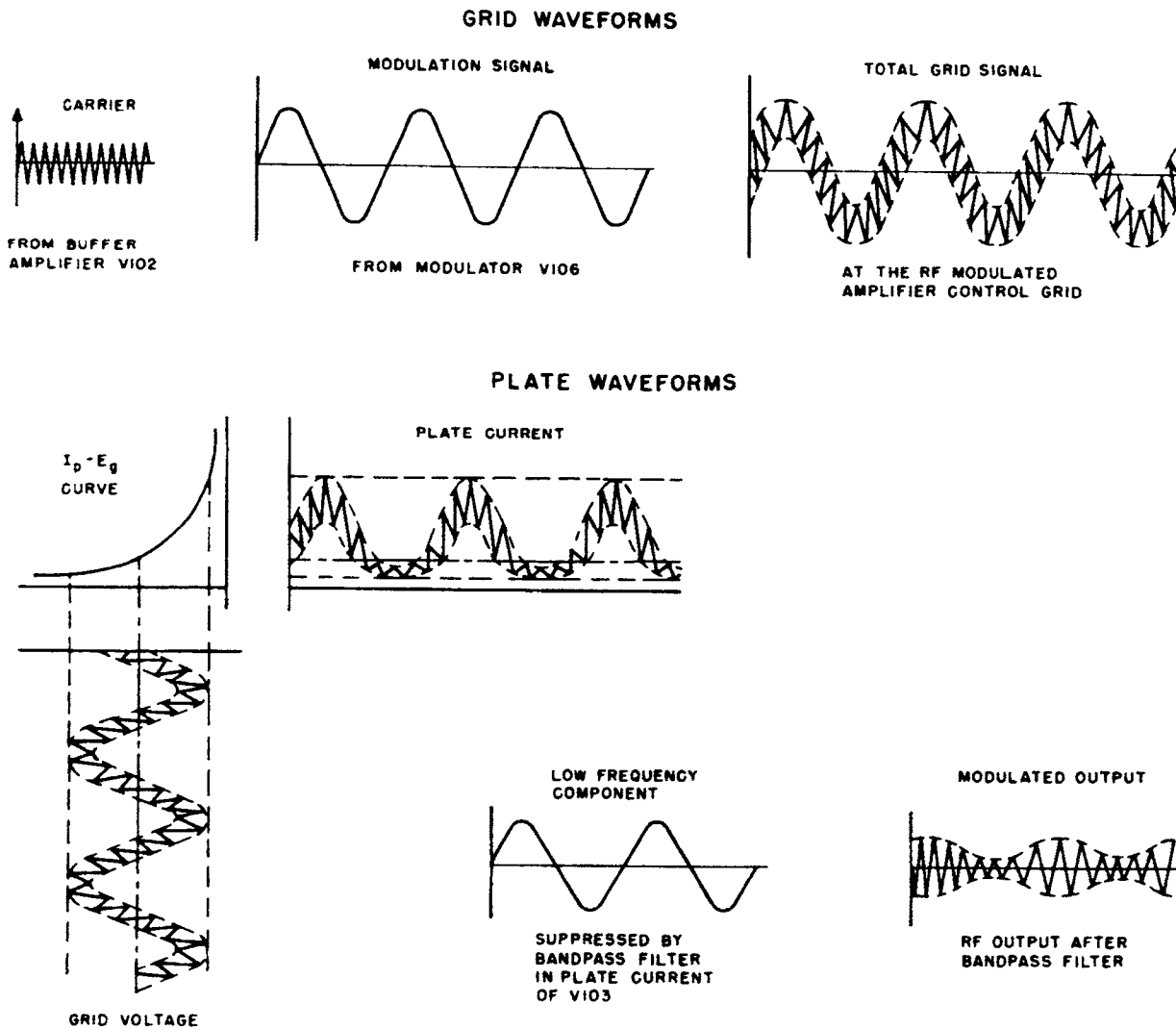

Figure 2-5. RF Modulator Amplifier Waveforms Van der Bijl Modulation

effective grid circuit resistance of 110,000 ohms. This high grid resistance prevents the loss of RF carrier at 10 kilocycles in the coupling capacitor C112. Modulation frequencies up to 1000 cycles appear at the grid without loss.

i. RF Metering and calibration voltages are taken from the plate circuit of the RF modulated amplifier. Details of each circuit are covered separately in paragraphs 9 and 10.

**5. RF OUTPUT.** (See figure 2-6.)

a. The RF output level is set by MICROVOLTS control R109 and SET RF OUTPUT control R135. When the signal generator has been set to the desired frequency, the MICROVOLTS control is turned to maximum and the SET RF OUTPUT is adjusted so that meter M101 reads in the red arc. Thereafter, fine adjustments of output are made by the MICROVOLTS control. This procedure sets the RF oscillator output

voltage to a value just sufficient to drive stages V102 and V103 correctly. Failure to observe this procedure results in high carrier distortion due to excessive overloading of buffer amplifier.

b. Two RF output circuits are available. One, the HIGH RF OUTPUT jack (J101), has an open circuit voltage of 2 volts and a source impedance of 500 ohms. The other is a calibrated signal from 100,000 microvolts to 0.1 microvolt with a source impedance of 50 ohms.

c. The HIGH RF OUTPUT jack (J101) has a switch built into it that grounds the center pin of the jack and removes it from the RF modulated amplifier circuit when the jack is not in use. UG/88U plug is used to connect from this jack to an external circuit. When the plug is inserted into the jack, the built-in switch is opened, ungrounding the center pin and connecting it to the output of V103.

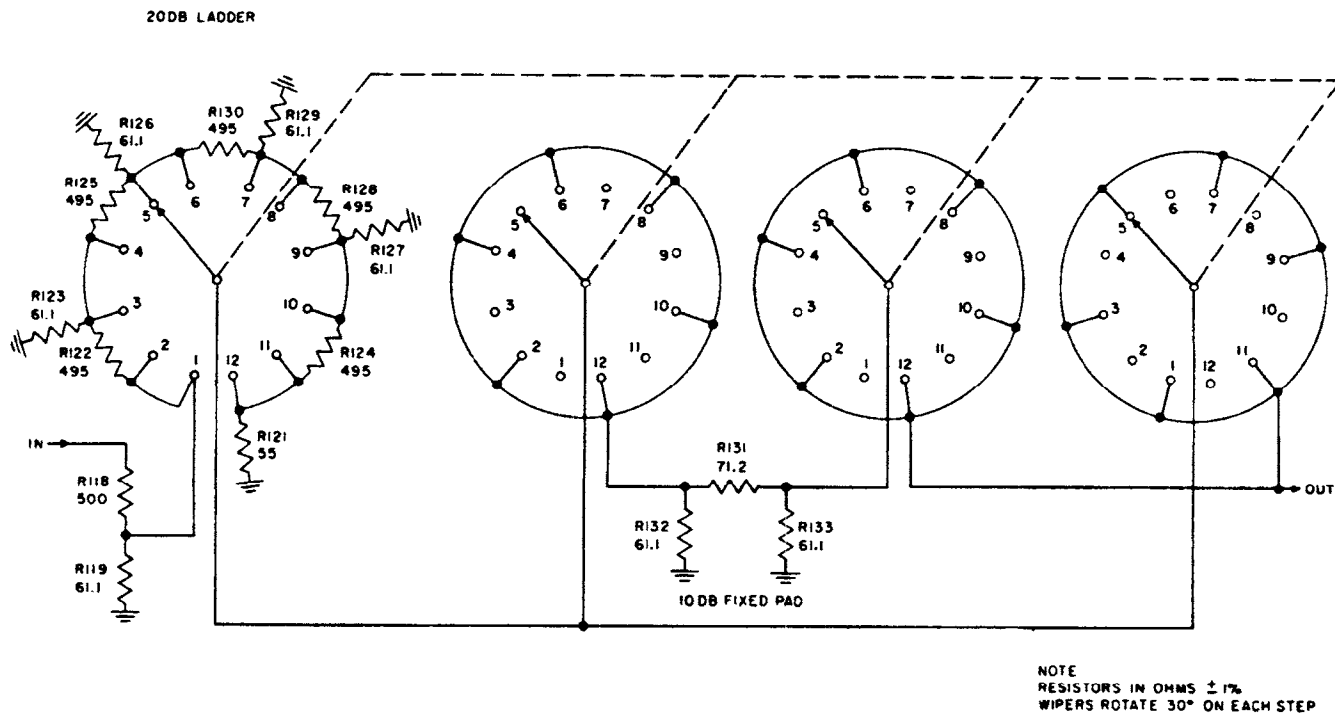

Figure 2-6. RF Output Step Attenuator Simplified Schematic

d. The RF output at the HIGH RF OUTPUT jack (J101) is 2 volts into an open-circuit load. This is obtained when meter M101 reads 10.

e. The calibrated signal from J102 is obtained via a step attenuator, which varies the output in steps of 10 db to a maximum of -110 db below 100,000 microvolts. Fine variations of output between each step are obtained by using the MICROVOLTS control.

f. The switching action of the step attenuator is shown in figure 2-6.

g. The attenuator consists of a 12-position switch and 13 precision resistors. A detent provides stops and clicks at 30° intervals. A  $\pi$  ladder circuit maintains constant impedance regardless of the amount of attenuation. The attenuator is constructed in two decks to conserve space. Internal shielding prevents leakage between the decks. One deck contains a fixed 10-db pad and the other a six-section, 20-db loss-per-section ladder attenuator. The fixed 10-db pad is switched in and out between each section of the 20-db ladder. In the 100,000-microvolt step (position 1) the 10-db pad and the 20-db per-section ladder are out of the circuit completely and no reduction in signal strength occurs. The 30,000-microvolt step (position 2) uses the fixed 10-db pad only and a 10-db reduction in signal strength occurs. The 1000-microvolt step (posi-

tion 3) uses only the first section of the 20-db ladder; loss is now 20 db. In the 3000-microvolt step (position 4) the 10-db fixed pad is switched in and, with the first section of the 20-db ladder, produces 30-db of loss. The 1000-microvolt step (position 5) cuts out the fixed 10-db pad and uses two 20-db sections of the ladder; the loss becomes 40 db. By alternately switching the 10-db fixed pad in and out of the circuit and adding successive 20-db sections of the ladder, the total attenuation of 110 db can be obtained.

b. This style of attenuator has the unique advantage of being self-checking (see section 7, paragraph 20) and capable of checking the accuracy of the microvolts scale calibration of M101.

i. When the attenuator is at the position for 100,000 microvolts output, the jack is connected to the top end of R119. See figure 2-4. The combination of R118 and R119 attenuates the signal from 2 volts to 0.2 volt. When a 50-ohm termination is used across J102 (thus properly terminating the generator), 100,000 microvolts appears across the termination. This is the voltage indicated on the meter M101. It cannot be too heavily stressed that the output voltage from J102 is only indicated correctly by the meter M101 when the generator is terminated by its correct impedance, 50 ohms. See paragraph 9, section 4 "Operation" for termination methods.

**6. AUDIO OSCILLATOR.** (See figure 2-7.)

a. The audio oscillator supplies signals for modulating the RF carrier and signals for external testing of audio equipment. Two frequencies, 400 and 1000 cycles, are generated and are selected by the front panel FUNCTION SWITCH (S103).

b. The audio oscillator operates only in the INT. MOD. positions (positions 4 and 5) of the FUNCTION SWITCH. When the switch is in CW or EXT MOD positions (positions 2 and 3) the audio oscillator is *not* operating. In position 1 circuit components are switched by the FUNCTION SWITCH to operate as a headphone amplifier for calibrating purposes (see paragraph 9 below).

c. The audio circuit is a standard Wien bridge audio oscillator. Two tubes, V104 and V105, are each triode-connected and arranged to oscillate through a frequency-selective network. The network components, R136, R140, R142, R143, R144, R147, C130, and C131 are bridge-connected and allow positive feedback to occur at 400 cycles. When the FUNCTION SWITCH is turned to the 1000-cycle position, R136 and R140 are replaced by R137 and R141 respectively. These new values change the frequency of oscillation to 1000 cycles.

d. DEGEN control R143 is part of the bridge circuit. It forms part of the negative feedback loop and is adjusted to maintain oscillation with a minimum of distortion.

e. The output level is stabilized by using the grid and cathode of V105 as a diode to provide grid-leak bias.

f. The audio output is coupled through the % MOD control R151 and out to the AUDIO OUT jack J104. When using J104 to obtain the external audio signal, equipment with high impedance, 100,000 ohms or higher, should be used to obviate loading of the audio oscillator and to prevent loss over the filter network. The % MOD control also feeds the grid of the modulator stage. Refer to paragraph 7 for modulator stage details.

g. A RF filter composed of R153, R154, R183, C137 and C138 eliminate RF leakage through the AUDIO OUT jack.

**7. MODULATOR.** (See figures 2-8 and 2-9.)

a. The modulator is a single pentode stage operating as a cathode follower for the modulating signal and as a conventional amplifier for the modulation metering circuit.

b. Modulator tube V106 performs either as a modulator or as an oscillator. When the FUNCTION SWITCH is set in EXT MOD or 400-cycle and 1000-cycle INT MOD positions (3, 4, and 5 respectively), the tube operates as a modulator stage. In position 1 the stage becomes a crystal oscillator. See paragraph 8 for details. Position 2 of the FUNCTION SWITCH (E103) grounds the modulator grid and prevents modulation.

c. The input signal to the modulator stage is obtained from either the internal audio oscillator or an external modulation source through J104. The FUNCTION SWITCH (S103) sets the mode of operation. Figure 2-8 shows the signal path for external modulation input. Audio signals enter J104 and are applied across % MOD control R151. RF filter R153, R154, R183, C137 and C138 prevents any RF leakage from the generator, thus reducing a radiation to the external audio source and its connections.

d. Figure 2-9 illustrates signal path when the internal audio oscillator is used. The output of the audio oscillator is coupled to % MOD control R151 through resistor R152. This resistor isolates the audio oscillator from the circuits following R154. The arm of the control varies the percent of modulation and the amplitude of audio output at the AUDIO OUT jack.

e. Bias for the cathode follower stage is supplied by R157. The modulator output signal, taken from cathode resistor R158, is supplied to RF modulated amplifier. MOD METER ADJ control R158 is a preset adjustment used to set the level of modulation. The modulating signal flows out of the arm of R158 through coupling condenser C141 and appears across R159, which is connected to R112 of the RF modulated amplifier. The modulation circuit is covered in paragraph 4.

f. The plate output of the modulator stage develops the modulating signal across R156. This amplified voltage deflects the front panel meter when the FUNCTION SWITCH is in the MOD positions. Refer to paragraph 10 for metering circuit theory.

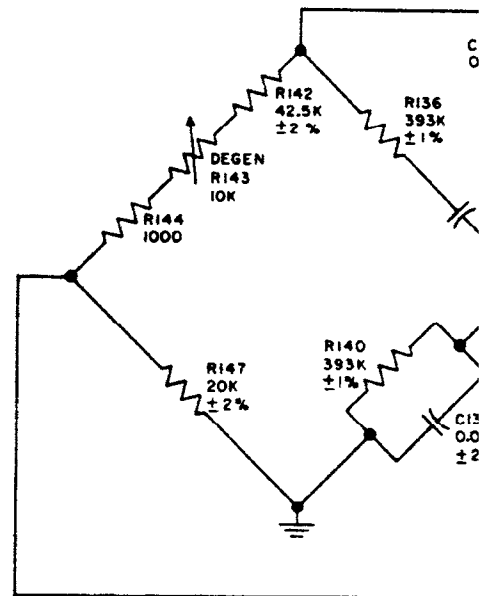

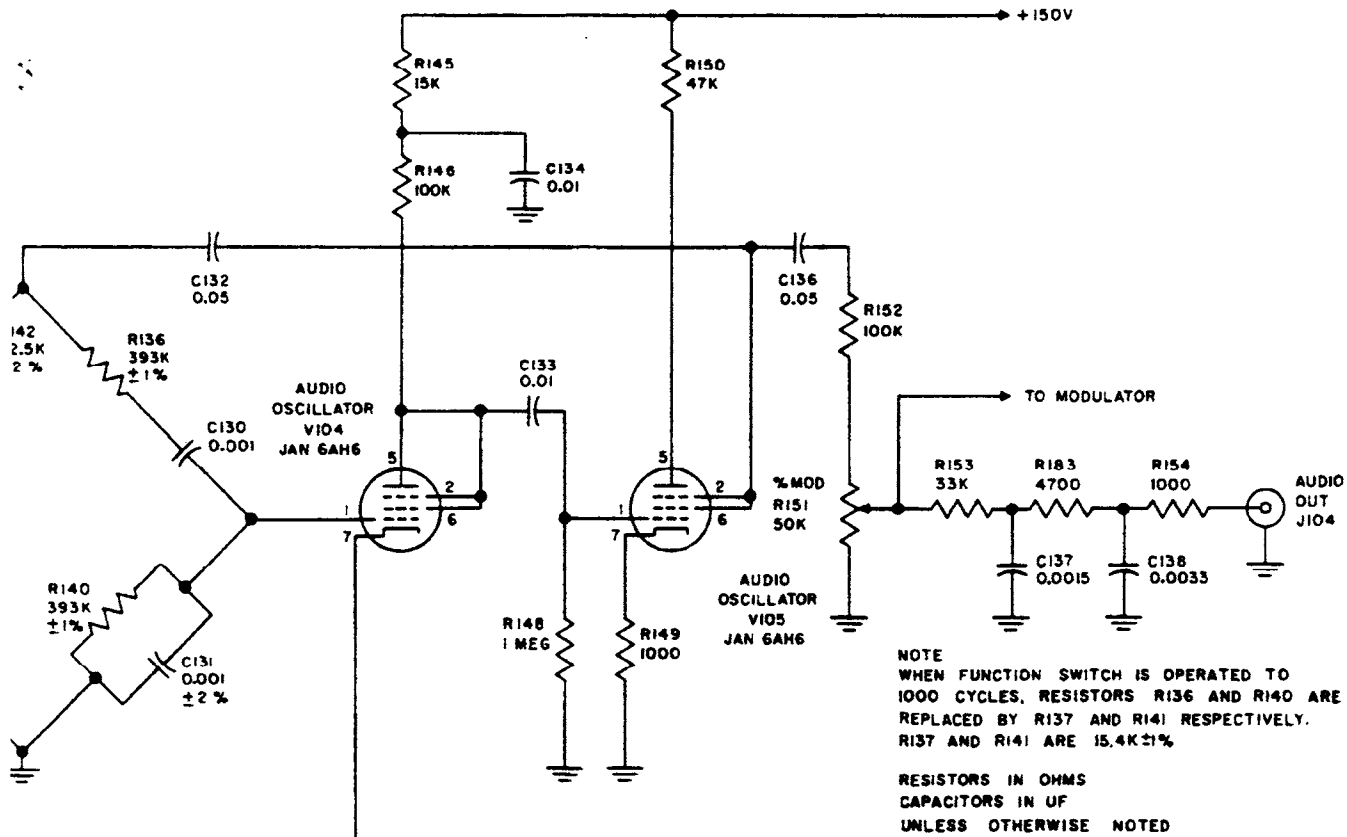
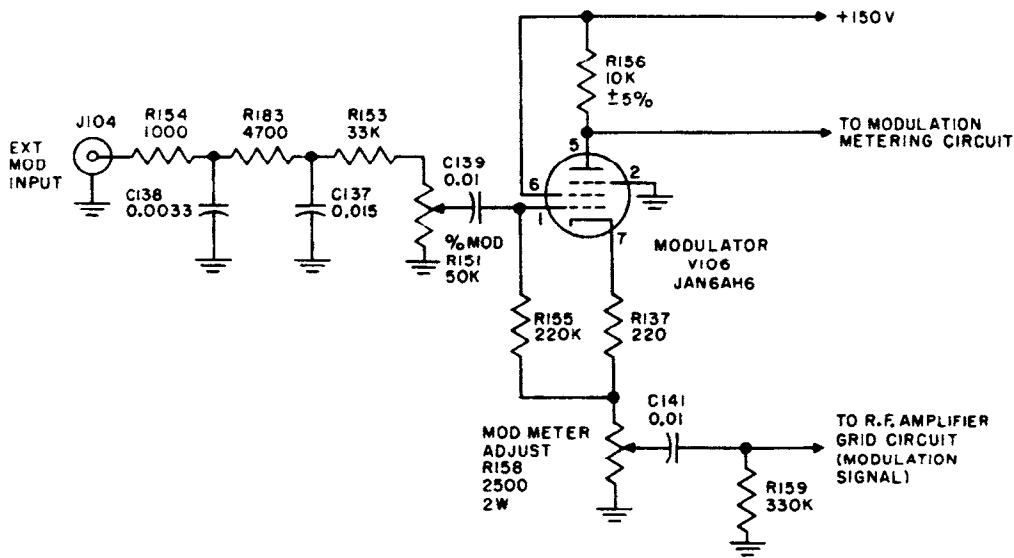
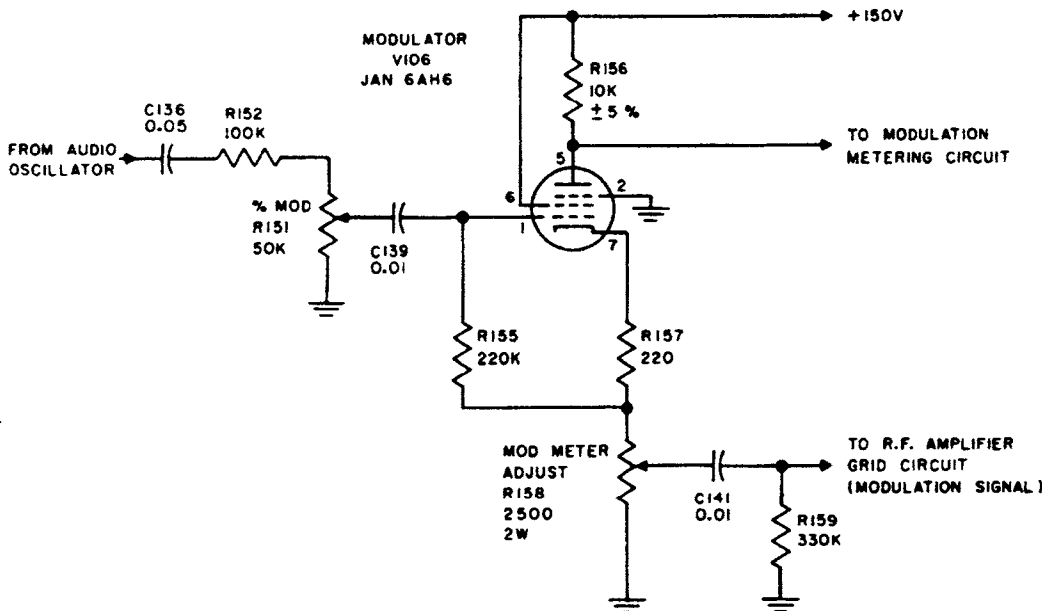

Figure 2-7. Wien Bridge Audio Oscillator  
 Simplified Schematic



NOTE  
RESISTORS IN OHMS  
CAPACITORS IN UF  
UNLESS OTHERWISE NOTED

Figure 2-8. Modulator, External Modulation Simplified Schematic



NOTE  
RESISTORS IN OHMS  
CAPACITORS IN UF  
UNLESS OTHERWISE NOTED

Figure 2-9. Modulator, Internal Modulation Simplified Schematic

**8. CRYSTAL OSCILLATOR.** (See figure 2-10.)

a. The crystal oscillator is used as a calibration standard on frequencies of 1 megacycle or higher. Frequency accuracy of the signal generator, when aligned with the crystal calibrator, is within  $\pm 0.05$  percent at any frequency above 15 megacycles. At any frequency where calibration beat notes occur, frequency accuracy is 0.005 percent at the zero beat at normal room temperature. No provisions are made for calibration below 1 megacycle where dial markings are within  $\pm 0.5$  percent.

b. The crystal oscillator uses a single 6AH6 tube. The tube functions as an oscillator in position 1 (CAL) of the FUNCTION SELECTOR and as a modulator in positions 3, 4 and 5. Refer to paragraph 7 for modulator operation.

c. The crystal oscillator is a modified Pierce oscillator. The circuit oscillates at the crystal frequency of 1 megacycle. The 1 megacycle output of the oscillator has an RMS value of approximately 15 volts. A trimmer in the grid circuit is a preset adjustment and provides a means for varying the crystal frequency

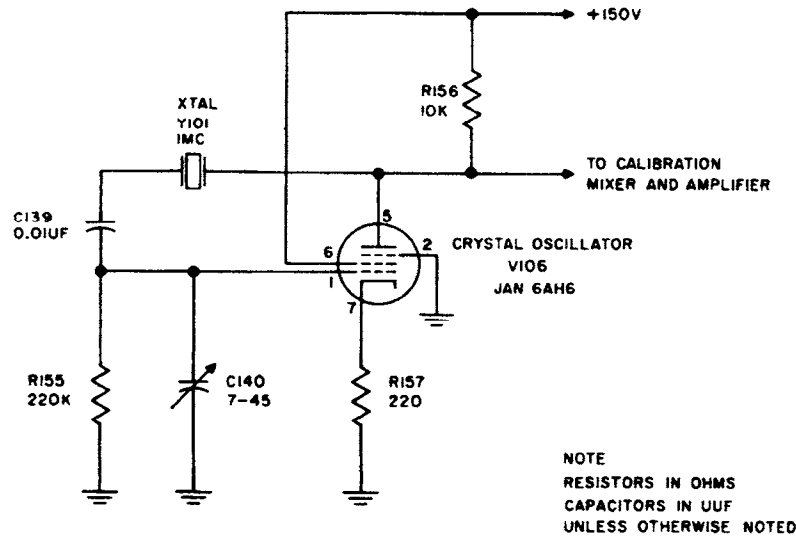

Figure 2-10. Crystal Oscillator Simplified Schematic

within small limits. This adjustment permits calibration with an external frequency standard to an accuracy of  $\pm 0.005$  percent.

d. Normal operating bias is obtained by grid current through R155. R157 is to prevent excessive current flow in the event of oscillator failure.

e. The use of the crystal calibrator is covered in detail in the next paragraph (calibrating amplifier).

### 9. CALIBRATING MIXER AND AMPLIFIER.

(See figure 2-11.)

a. The calibrating amplifier strengthens the beat notes obtained when operating the calibrating circuits. The inputs to the amplifier are the crystal oscillator and RF output of the signal generator. The output signal obtained at J104 enables the operator to audibly establish calibration, when using a pair of high impedance headphones.

b. The calibrating amplifier uses two stages of amplification. Tubes V104 and V105 are connected as amplifiers when the FUNCTION SELECTOR is in the CAL position (1). These tubes function as a Wien bridge audio oscillator in positions 3, 4 and 5 of the FUNCTION SELECTOR. Refer to paragraph 6 for audio oscillator operation.

c. The outputs of the crystal oscillator and the RF amplifier are applied to CR102 via the small capacitors C116 and C119. The signal from the crystal oscillator is rectified by CR102 producing rich harmonics of the crystal frequency. These frequencies mix with the CW output of the generator giving rise to audible beat notes which pass through the filter network R115, C117, R139, C128, which removes the remaining RF signal. The beat note is amplified by the two-stage resistance-coupled audio amplifier and is coupled to CAL OUT jack J104 through an additional RF filter. Components R153, R183, R159, C137, C138 remove

any RF which may get through to the amplifier. Inverse feedback from the cathode of V105 through C129 reduces gain at RF frequencies. The high degree of RF filtering produces a clean beat signal in the calibrating headphones.

### 10. RF AND MODULATION METERING.

(See figures 2-12 and 2-13.)

a. Two metering circuits are incorporated to monitor the signal generator output. Operation of the circuits depends upon the position of the FUNCTION SWITCH. A front panel meter, calibrated in percent modulation and microvolts, measures either audio level of RF amplitude, depending upon the position of the FUNCTION SWITCH. R163 and C143 constitute an RF filter which prevents leakage of the RF signal from the meter in the form of radiation. The hermetically sealed and preadjusted meter has a basic movement of 100 microamperes full scale deflection.

b. Figure 2-13 is a simplified schematic of the RF metering circuit in operation in the CAL and CW positions of the FUNCTION SWITCH. The RF output of the signal generator is rectified by germanium diode CR101. A DC voltage, proportional to the carrier strength, is developed and fed to the meter through multiplier resistors R116 and R160. Calibrating resistor R160 is adjusted so that when the signal generator output is 2 volts RF at J101 (open circuit) the meter indicates 10 on the microvolts scale. This then sets the accuracy of the output to be obtained at J102. The diode load at high frequencies consists of C120, R116, R160, R163 and the resistance of M101 in series. At low frequencies, it consists essentially of C120 and C121 in parallel together with the above load resistors. Resistor R117 nullifies any inductive effect exhibited by C121 at high frequencies that might render the meter calibration inaccurate at these frequencies.



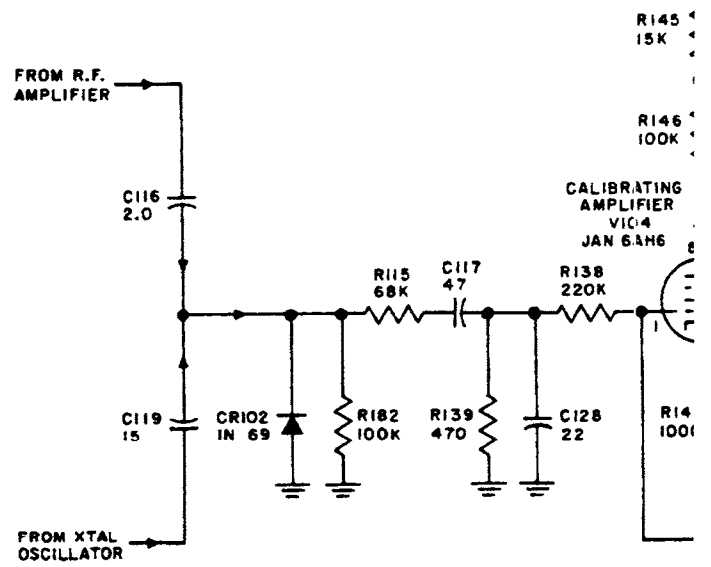

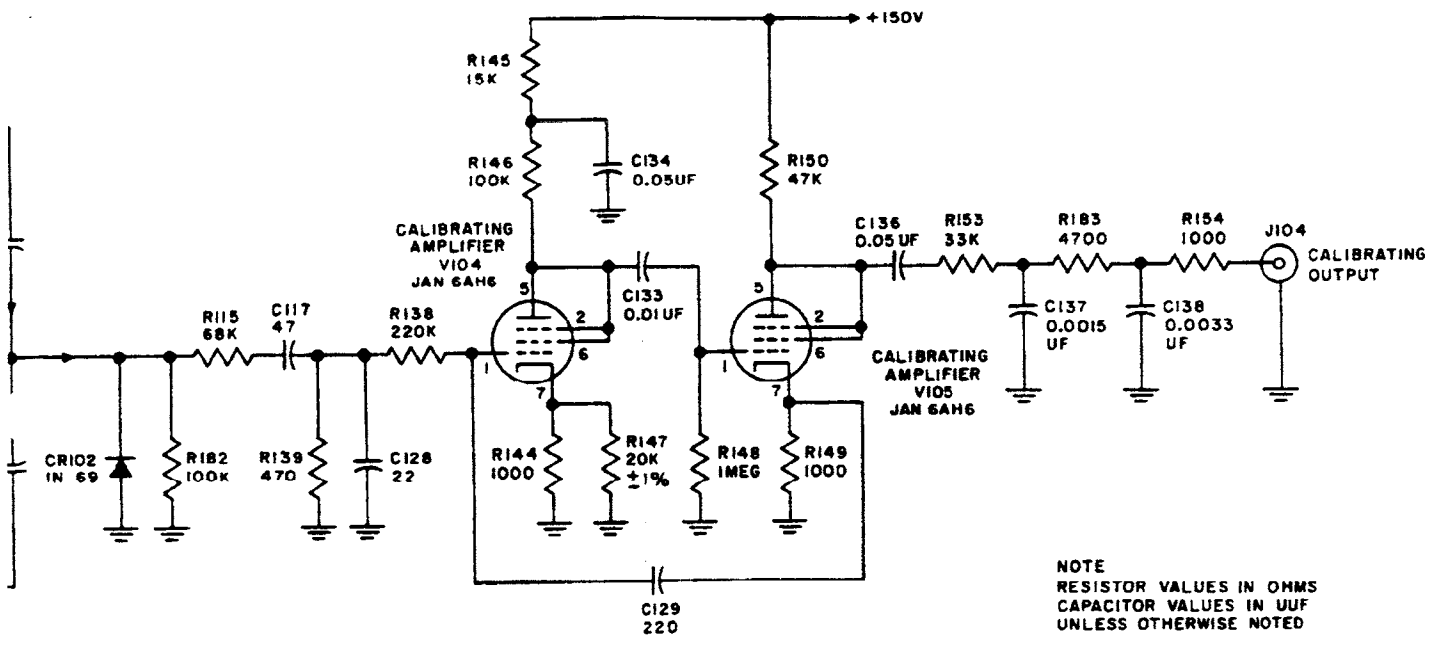

NOTE  
 RESISTOR VALUES IN OHMS  
 CAPACITOR VALUES IN UUF  
 UNLESS OTHERWISE NOTED

Figure 2-11. Calibrating Mixer and Amplifier  
 Simplified Schematic

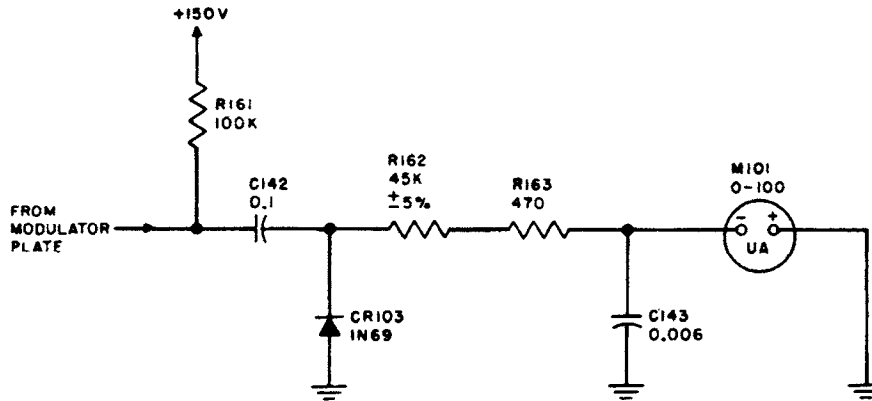

NOTE  
RESISTORS IN OHMS  
CAPACITORS IN UF  
UNLESS OTHERWISE NOTED

Figure 2-12. Modulation Metering Simplified Schematic

c. Figure 2-12 shows the modulation meter circuit which is effective in the MOD positions (3, 4, and 5) of the FUNCTION SWITCH. The circuit determines the percentage of modulation indirectly by measuring the amplitude of the audio signal. (To determine the modulation percentage directly, the amplitude of the envelope would have to be measured.) MOD METER ADJ, R158, located in the cathode of the preceding modulator stage, sets the actual percentage of modulation to conform with the meter scale calibration.

d. The meter deflecting signal is developed across R156 in the plate circuit of the preceding modulator tube. It is then coupled to germanium diode CR103 by capacitor C142. Resistor R161 prevents switching transients from breaking down diode CR103. The diode rectifies the audio signal and produces DC for meter deflection. Resistor R162 is the meter multiplier.

11. POWER SUPPLY PP-1322/URM-25F.

(See figure 2-14.)

a. The power supply provides both plate and heater power to the signal generator. The components are mounted on the right side of the case and are part from the signal generator chassis. A cable equipped with an Elco connector carries the AC and DC voltages to and from the power supply. The input voltage to the power supply is 115 volts. Voltage variations of 10 percent will not adversely affect circuit operation. Power frequencies may be from 50 to 1000 cycles.

b. The power supply is a conventional full-wave rectifier. A power transformer isolates the line and steps up the incoming AC voltage for plate supplies and reduces the voltage for heater requirements. Resistors R601 and R602 prevent excessive surge currents in V601. Filtering is accomplished by a modified  $\pi$  net-

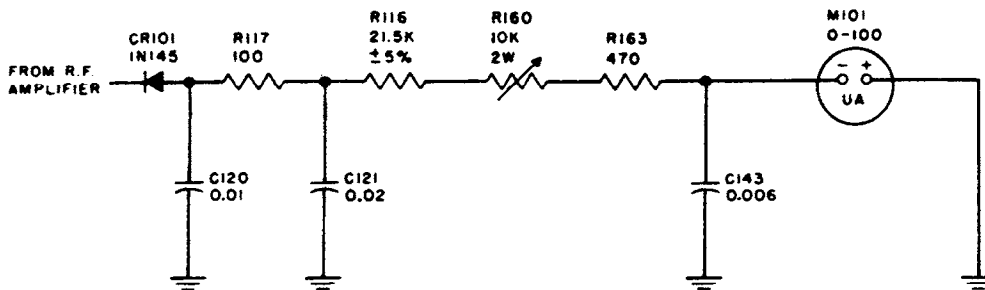

NOTE  
RESISTORS IN OHMS  
CAPACITORS IN UF  
UNLESS OTHERWISE NOTED

Figure 2-13. RF Metering Simplified Schematic

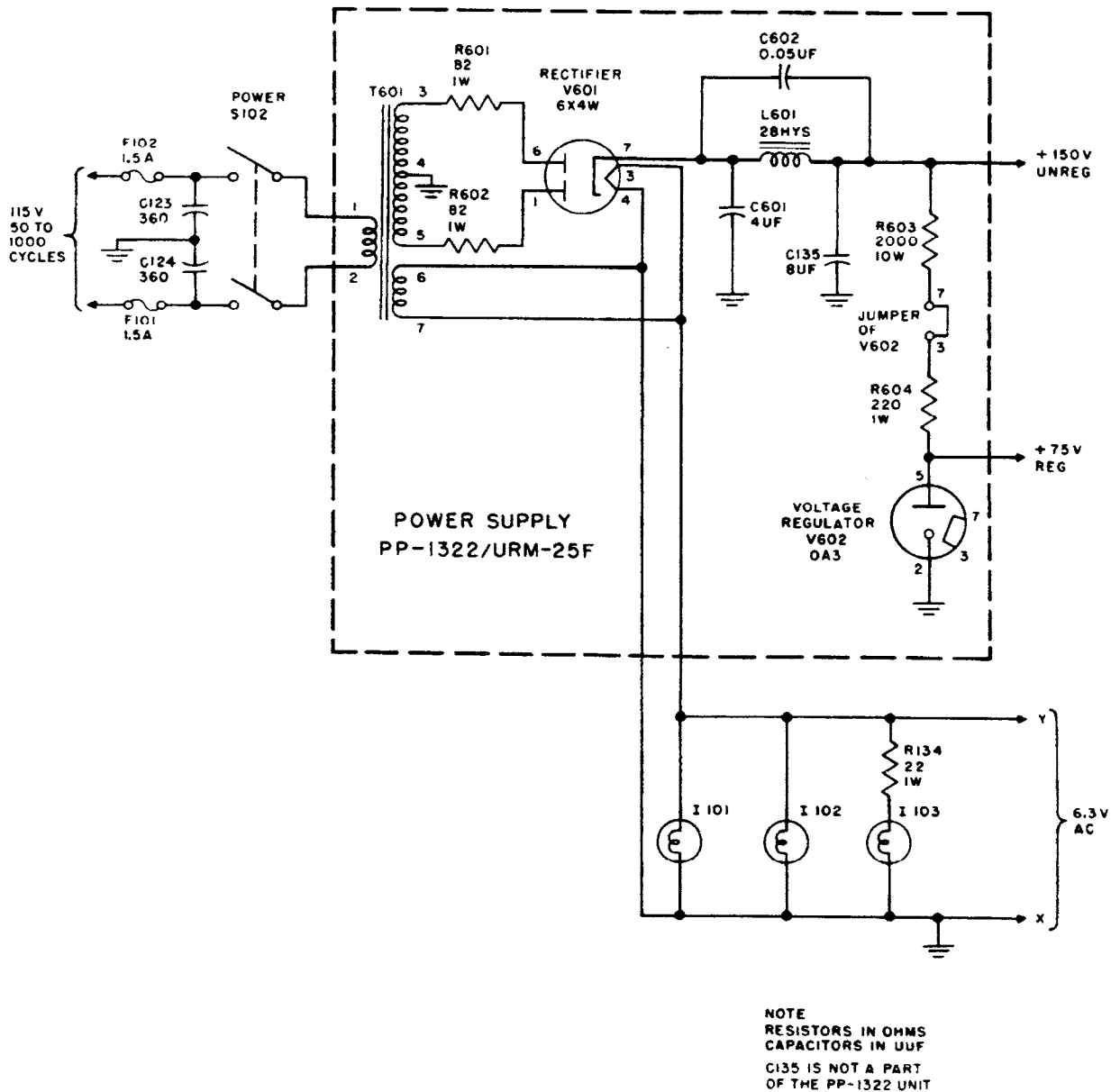

Figure 2-14. Power Supply PP-1322/URM-25F Simplified Schematic

work consisting of reactor L601 and capacitors C601, C602 and C135. Capacitor C602 resonates with the reactor at approximately 110 cycles. This resonance is quite broad and its purpose is to increase the effectiveness of the filter between 100 and 150 cycles (power supply frequencies of 50 to 75 cycles) thus keeping the B-supply ripple within the required limits. This could not otherwise be obtained without excessively large component values or an additional filter section. Above 150 cycles the ripple voltage across C601 becomes so small that capacitor divider C602-C135 is sufficient to keep the B-supply ripple within the required limits. The unregulated output voltage is 150 volts.

c. A regulated 75-volt supply consisting of a voltage regulator tube OA3 and associated dropping resis-

tors R603 and R604 develops the RF oscillator plate supply. By regulating this voltage, variations due to line voltage changes are eliminated. The jumper in the OA3 base removes plate supply from the RF oscillator stage should the VR tube be removed.

d. Parallel-connected heaters and dial lamps are powered by a secondary winding of 6.4 volts AC. This winding is grounded at one point on the signal generator chassis to avoid heater currents through the chassis of the generator. Input to the power supply is fused; these fuses are removable from the front panel. Power switch S102 breaks both sides of the line for maximum protection. Capacitors C123 and C124 prevent leakage from the signal generator to the power line. The switch, fuses, power plug, line filter capaci-

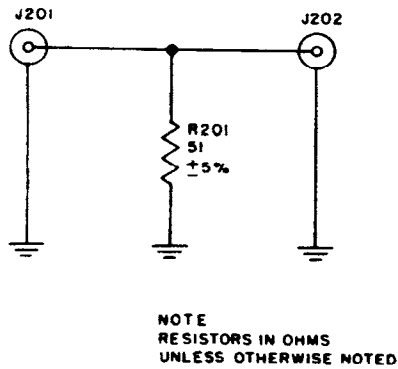

Figure 2-15. Impedance Matching Unit CU-406/URM-25F Simplified Schematic

tors, dial lamps and filter capacitor C135 are mounted on the signal generator chassis, and hence are separated from the power supply.

**12. IMPEDANCE MATCHING NETWORK  
CU-406/URM-25F.** (See figure 2-15.)

a. The Impedance Matching Network CU-406 connects the signal generator output to a high-impedance device; it prevents standing waves and errors due to impedance mismatching of the RF step attenuator.

b. The matching unit contains a 51-ohm, 5-percent carbon resistor. An aluminum can encloses the resistor and shields it from external fields. Input and output jacks are located on opposite ends of the can.

**13. IMPEDANCE MATCHING NETWORK  
CU-408/URM-25F.** (See figure 2-16.)

a. Impedance Matching Network CU-408 permits operating this 50-ohm signal generator into the 70-ohm impedance of Navy receivers.

b. The network consists of a  $\pi$  attenuator designed to reflect the proper impedances to both signal generator and receiver under test. Due to the nature of the

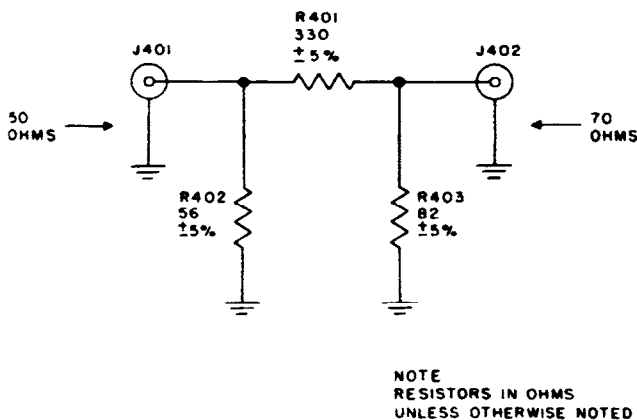

Figure 2-16. Impedance Matching Network CU-408/URM-25F Simplified Schematic

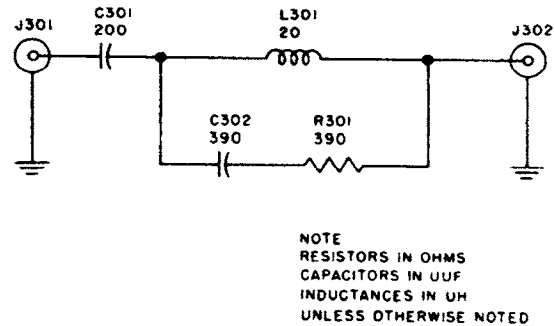

Figure 2-17. Electrical Dummy Load DA-109/URM-25F Simplified Schematic

attenuator matching device a loss of 20 db in signal intensity must be allowed for in measurements.

c. Physically, the matching unit consists of an aluminum can housing the three precision resistors. The can has input and output connectors located on opposite ends. Encasing the matching pad is necessary to prevent interference pickup.

**14. DUMMY LOAD DA-109/URM-25F.**  
(See figure 2-17.)

a. Dummy Load DA-109/URM-25F is required in making overall measurements on receivers which use a standard antenna. It approximates the conditions that would exist if an antenna were connected.

b. The dummy load components are contained in an aluminum can with the input and output jacks mounted on the opposite ends. The circuit consists of a 200-micromicrofarad capacitor (C301) and a series-parallel arrangement of a 390-micromicrofarad capacitor (C302), a 390-ohm resistor (R301) and a 20-microhenry inductor. At frequencies above 2.5 megacycles, the dummy load acts as a pure resistance of 220 to 400 ohms. Below 1.6 megacycles, the circuit acts as a 200-micromicrofarad capacitance in series with 20-microhenry inductance and a 15-ohm resistance. Refer to figure 4-3 for impedance curve.

c. The use and connection of the dummy load is fully described in section 4.

**15. TEST LEAD CX-2919/U.** (See figure 2-18.)

a. The test lead is used when making point-to-point measurements. It consists of a blocking condenser shielded by an aluminum can. A connector on one end of the can enables connection to the signal generator and two leads with alligator clips on the opposite end permit connection to the equipment under test. The capacitor prevents DC potentials from entering signal generator and causing damage.

b. Since the test lead is not a part of the 50-ohm impedance system, the output accuracy of the signal generator is no longer maintained, particularly at high RF frequencies. Details of use are covered in OPERATION, section 4.

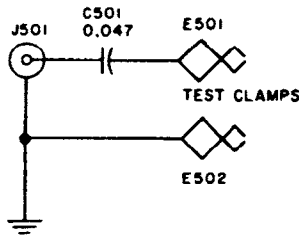

NOTE  
CAPACITOR IN UF  
UNLESS OTHERWISE NOTED

Figure 2-18. Test Lead CX-2919/U  
Simplified Schematic

16. CORD CG-409A/U.

a. Three cords are supplied to connect the impedance matching units, the dummy load and the test lead to the signal generator. These cords are lengths of 52-ohm coaxial cable with AN/UG-88/U connectors on opposite ends. Two of the cords are approximately

6 inches in length and are used to connect the external termination units. The third cord, 4 feet in length, carries the signal to the receiver under test.

TABLE 2-1  
BAND SWITCH FREQUENCY RANGES

BAND	RANGE
1	10 Kilocycles to 26 Kilocycles
2	26 Kilocycles to 75 Kilocycles
3	75 Kilocycles to 220 Kilocycles
4	220 Kilocycles to 600 Kilocycles
5	.6 Megacycles to 1.5 Megacycles
6	1.5 Megacycles to 3.8 Megacycles
7	3.8 Megacycles to 10 Megacycles
8	10 Megacycles to 25 Megacycles
9	25 Megacycles to 50 Megacycles

TABLE 2-2  
COMPONENT VALUES OSCILLATOR TRANSFORMER ASSEMBLIES

FREQUENCY	SYM. REF.	C <sub>a</sub>	C <sub>b</sub>	C <sub>c</sub>	R <sub>a</sub>	R <sub>b</sub>	J <sub>a</sub>	T <sub>a</sub>
10-26 KC	Z 101	C 146 4-30	C 147 47	C 148 470	R 168 1 Meg	R 169 22K	short	T 102
26-75 KC	Z 102	C 149 4-30	C 150 22	C 151 470	R 170 470K	R 171 10K	short	T 103
75-220 KC	Z 103	C 152 4-30	C 153 15	C 154 390	R 172 330K	R 173 6.8K	short	T 104
220-600 KC	Z 104	C 155 4-30	C 156 33	C 157 270	R 174 100K	R 175 4.7K	short	T 105
0.6-1.5 MC	Z 105	C 158 3-13	C 159 7	C 160 100	R 176 100K	R 177 3.3K	open	T 106
1.5-3.8 MC	Z 106	C 161 3-13	C 162 15	C 163 270	R 178 47K	short	open	T 107
3.8-10 MC	Z 107	C 164 3-13	C 165 10	C 166 220	R 179 15K	short	open	T 108
10-25 MC	Z 108	C 167 3-13	C 168 15	C 169 100	R 180 10K	short	open	T 109
25-50 MC	Z 109	C 170 3-13	C 171 15	C 172 220	R 181 4.7K	short	open	T 110

COMPONENT FUNCTIONS

- C<sub>a</sub>—trimmer capacity
- C<sub>b</sub>—temperature compensating capacitor
- C<sub>c</sub> } R<sub>c</sub> grid leak combination
- R<sub>a</sub> }

- R<sub>b</sub>—cathode feedback resistor
- T<sub>a</sub>—oscillator transformer
- J<sub>a</sub>—"short" indicates C101 and C102 used in parallel
- "open" indicates C102 used alone
- Symbol reference refers to each oscillator sector assembly

## SECTION 3 INSTALLATION

### 1. UNPACKING. (See figure 3-1.)

a. Signal Generator AN/URM-25F is packed in a V3C board box. Electron tubes are shipped in place. A set of spare parts is packed in a separate cardboard container.

b. The accessories for the signal generator are shipped in the front cover of the generator case. See figure 1-1 for location. The instruction book also fits into the front cover.

### 2. INSTALLATION.

a. The AN/URM-25F is a portable signal generator and does not require installation. The equipment is intended to be operated with front panel in vertical position.

b. The following settings are required prior to placing the equipment in operation. See figure 1-1.

1. Turn POWER switch (S102) to OFF position.
2. Turn SET RF OUTPUT control (E101) fully counterclockwise.
3. Turn % MOD control (E104) fully counterclockwise.
4. Connect power cable to 115-volt, 50- to 1000-cycle power source.
5. Release dial lock (E110).

### 3. ADJUSTMENTS.

a. There are no initial adjustments. All operating adjustments are described in section 4.

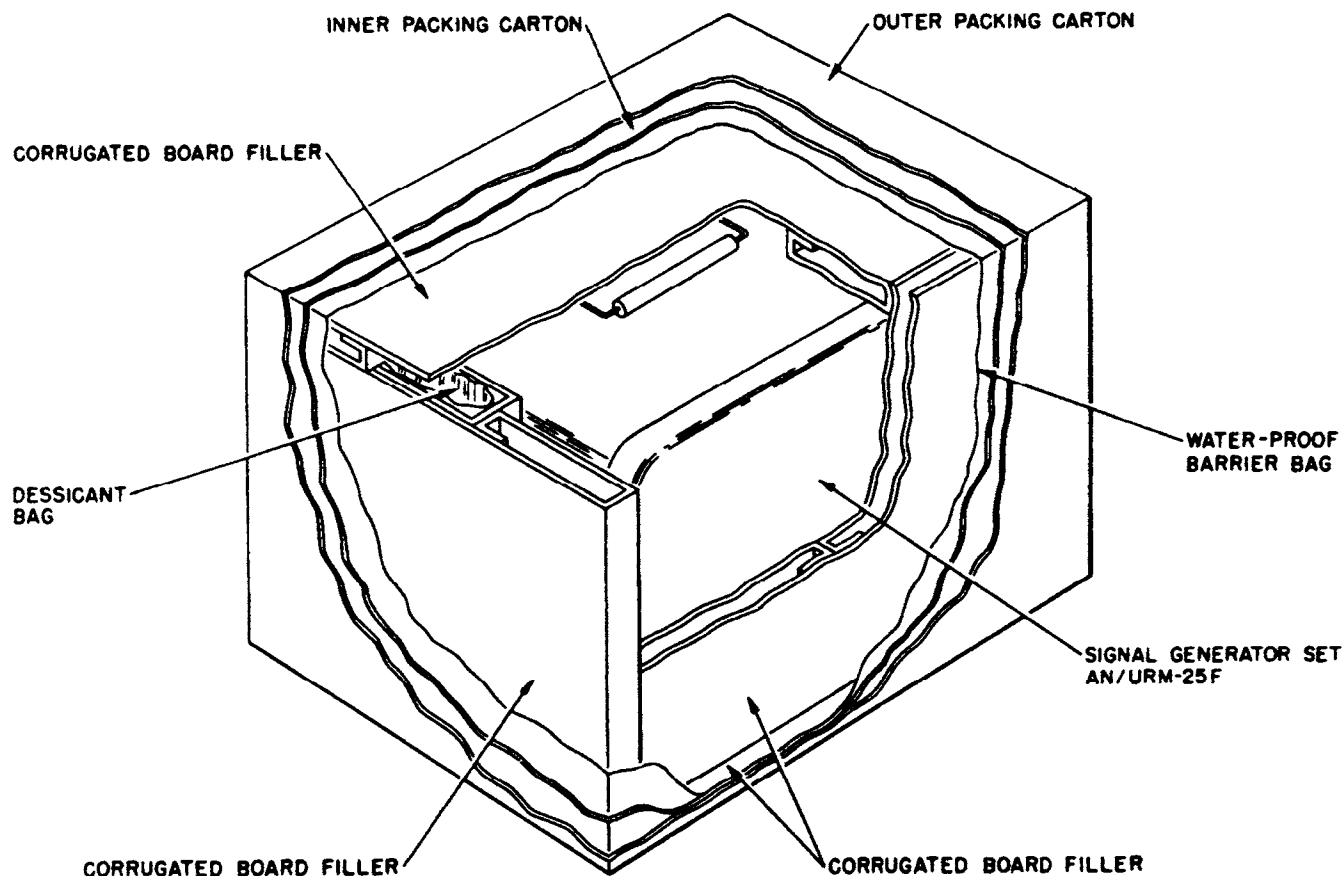

Figure 3-1. RF Signal Generator AN/URM-25F Packaging Diagram

## SECTION 4 OPERATION

### 1. GENERAL.

a. The essential details of operation and the precautions to be taken are covered in this section under the following paragraphs.

- (1) Power Circuits .....Par. 2
- (2) Setting Carrier Frequency .....Par. 3
- (3) Crystal-controlled Output .....Par. 4
- (4) Crystal Calibration .....Par. 5
- (5) Adjusting Output Voltage .....Pa. 6
- (6) Internal Modulation .....Par. 7
- (7) External Modulation .....Par. 8
- (8) Terminating the Signal Generator .....Par. 9
- (9) Coupling to Receiver Under Test .....Par. 10
- (10) Use of Dummy Load .....Par. 11
- (11) Using the Signal Generator .....Par. 12

### 2. POWER CIRCUIT. (See figure 4-1.)

a. Rotate the SET RF OUTPUT control knob (E101) and % MOD control knob (E104) fully counterclockwise before operating the POWER switch.

b. Plug the power cable into a source of 115-volt, 50- to 1000-cycle power.

c. Throw the POWER switch (S102) to the ON position. No other power switches are provided and the signal generation is now in operation. Allow minimum 15-minute warm-up period prior to setting the generator for use. This period permits the instrument to reach a stable operating state.

### 3. SETTING CARRIER FREQUENCY. (See figure 4-1.)

a. Nine frequency bands are available and are selected by the BAND SWITCH (E106). Ranges are marked

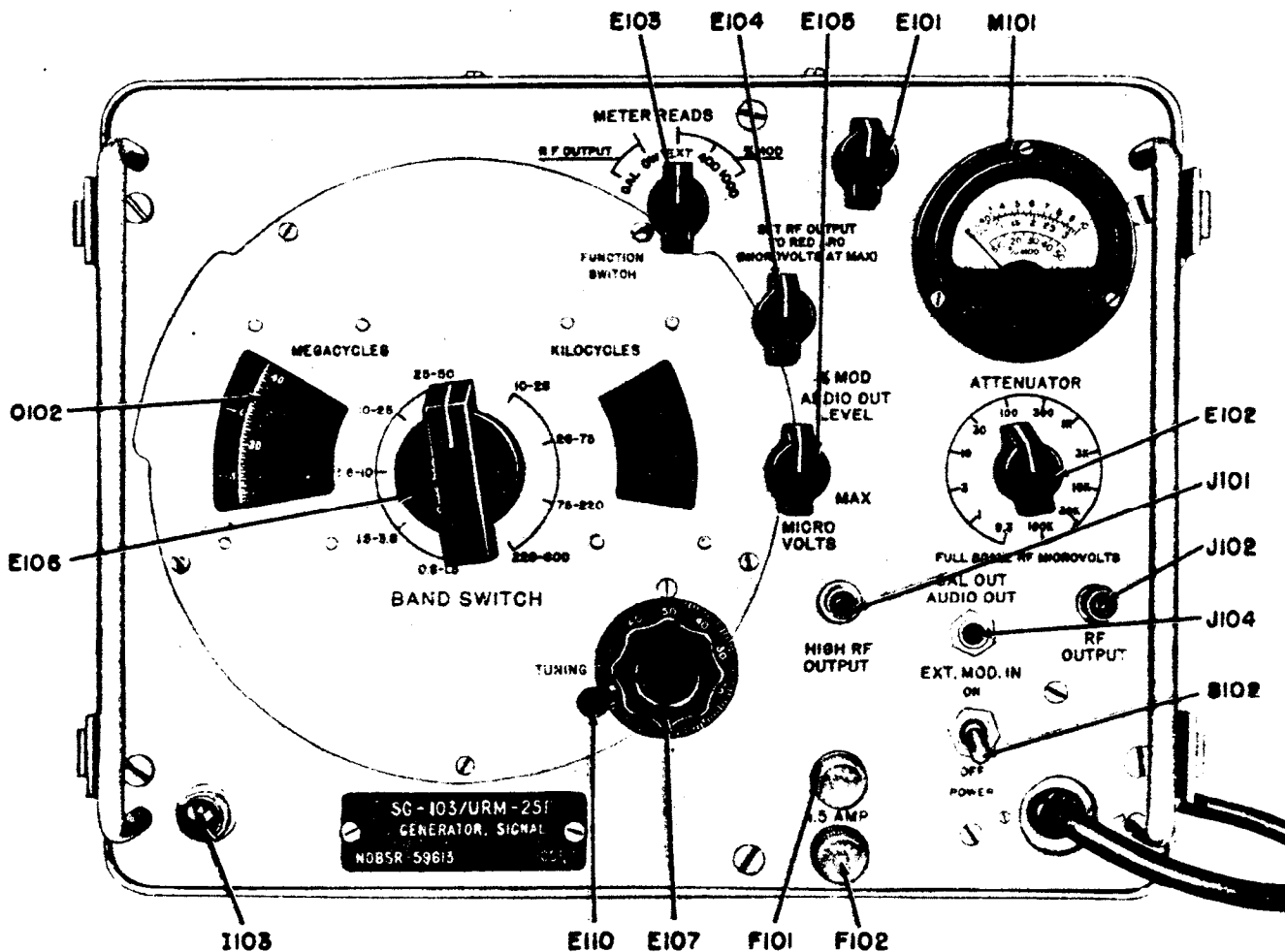

Figure 4-1. RF Signal Generator AN/URM-25F Front Panel



on the front panel. A scale mask is linked to this switch so that only the band scale selected will be visible.

*b.* An index scale calibrated linearly from 0 to 10 is located on the left side of the frequency dial (O102) and is visible in all positions of the BAND SWITCH. The TUNING knob (E107) is calibrated from 0 to 100. One complete revolution of the TUNING knob will move the index scale 1 division.

*c.* The following procedure should be observed for selecting the operating frequency of the signal generator.

(1) Turn SET RF OUTPUT control (E101) fully counterclockwise.

(2) Set FUNCTION SWITCH (E103) to CW position.

(3) Rotate BAND SWITCH (E106) to desired range.

(4) Release dial lock (E110).

(5) Turn TUNING knob (E107) until desired frequency coincides with index line.

(6) Read frequency directly from calibrated scale. It will be within  $\pm 0.5$  percent. Should greater accuracy be desired, the signal generator should be tuned against the built-in crystal oscillator as described in paragraph 5.

(7) If using the signal generator under conditions of heavy vibration, secure the TUNING knob by tightening the dial lock (E110).

TABLE 4-1. FUNCTION OF FRONT PANEL CONTROLS

Refer to figure 4-1

SYMBOL	PANEL CONTROL	FUNCTION
E106	BAND SWITCH	Selects desired frequency band. (See table 2-1).
E107	TUNING	Selects desired carrier frequency.
E103	FUNCTION SWITCH	<p><i>a.</i> Sets mode of operation as follows:</p> <p>(1) CALIBRATE</p> <p>(2) CW</p> <p>(3) EXTERNAL MODULATION</p> <p>(4) INTERNAL MODULATION 400 CYCLES</p> <p>(5) INTERNAL MODULATION 1000 CYCLES</p> <p><i>b.</i> Switches front panel meter for reading carrier output in CALIBRATE and CW position and percentage modulation in EXTERNAL MODULATION, INTERNAL MODULATION 400 AND 1000 CYCLE positions.</p>
E101	SET RF OUTPUT control	Sets level of RF OSC.
E105	MICROVOLTS control	Provides fine adjustment of RF output signal.
E102	RF Step ATTENUATOR	Provides coarse adjustment of RF output signal.
E104	% MOD control	<p><i>a.</i> Adjust percentage of modulation for internal and external modulation.</p> <p><i>b.</i> Adjusts output level of internal audio oscillator output.</p>
S102	POWER switch	ON-OFF switch for application of power.
I103	Pilot lamp	Lights when signal generator is ON.
I101	Dial lamp	Illuminates dial scales.
I102	Dial lamp	Illuminates dial scales.
J101	HIGH RF OUTPUT jack	2 volt open-circuit output, 500 ohms.
J102	RF OUTPUT jack	50 ohms step attenuator output.
J104	CAL OUT, AUDIO OUT, EXT MOD IN, jack	<p><i>a.</i> Output for calibrating headphones.</p> <p><i>b.</i> Output for internally generated audio signals.</p> <p><i>c.</i> Input for external modulation.</p>
M101	Meter	Indicates RF output voltage (upper scales), and percentage of modulation (lower scale).
F101, F102	Fuses (2)	Protects power supply.
O102	Frequency scale	Show frequency ranges.
E110	Dial lock	Locks TUNING control.

**4. CRYSTAL-CONTROLLED OUTPUT.**

(See figure 4-1.)

*a.* GENERAL. An internal crystal oscillator generates a 1 megacycle fundamental frequency and strong harmonics up to 50 megacycles. These signals can be used directly for testing external equipment. The accuracy of all crystal-generated frequencies above 1 megacycle is  $\pm 0.005$  percent.

*b.* PROCEDURE.

(1) Turn the SET RF OUTPUT control knob (E101) fully counterclockwise.

(2) Rotate the MICROVOLTS knob (E105) fully counterclockwise.

(3) Set the FUNCTION SWITCH (E103) to the CAL position.

(4) Obtain crystal output at either HIGH RF OUT jack J101 or RF OUT jack J102.

(5) Adjust the amplitude of the output signal with the step attenuator when using the RF OUT jack J101. The output at the HIGH RF OUT jack is not variable.

**Note**

The output voltage from the crystal oscillator is not calibrated and therefore readings on the meter or step attenuator are not true indications.

**5. CRYSTAL CALIBRATION.**

*a.* GENERAL. The internal crystal calibrator (V106) is used for setting the RF frequency of the signal generator between 1 and 50 megacycles. Accuracy at all crystal check points is  $\pm 0.005$  percent. Between crystal check points, the accuracy is  $\pm 0.05$  percent on frequencies above 15 megacycles.

*b.* PROCEDURE.

(1) Set signal generator to approximate frequency using dial scale (O102).

(2) Turn FUNCTION SWITCH (E103) to CAL position.

(3) Connect a pair of high-impedance headphones to CAL OUT jack (J104).

(4) Turn MICROVOLTS control (E105) fully clockwise.

**TABLE 4-2. PROCEDURE FOR FREQUENCY INTERPOLATION**

PROCEDURE	ILLUSTRATIVE EXAMPLE
<i>a.</i> Follow steps (1) through (6) of paragraph 5 <i>b</i> until zero beat is heard at a crystal check point just below the desired frequency.	<i>a.</i> If the frequency desired is 20.4 megacycles, tune to 20-megacycle crystal check point.
<i>b.</i> Record settings of index scale (E108), and TUNING knob vernier scale (E107).	<i>b.</i> If the index scale (E108) reads between 7 and 8 and the TUNING knob vernier scale reads 56, the numerical setting of this crystal check point is 756.
<i>c.</i> Rotate TUNING knob (E107) until next highest zero beat is heard.	<i>c.</i> In the case cited above, this would be the 21-megacycle crystal check point.
<i>d.</i> Record the new settings of the index scale (E108) and TUNING knob vernier scale.	<i>d.</i> If the index scale reads between 7 and 8 and the TUNING knob vernier reads 86, the numerical setting of this crystal check point is 786.
<i>e.</i> Subtract the reading recorded in step <i>b.</i> from that recorded in step <i>d.</i>	<i>e.</i> 756 (step <i>b.</i> ) from 786 (step <i>d.</i> ) is 30. This indicates that it requires 30 dial divisions to go from 756 (20 megacycles) to 786 (21 megacycles).
<i>f.</i> Determine the difference between the desired frequency and the lower check point. Multiply this by the number obtained in step <i>e.</i>	<i>f.</i> If the desired frequency is 20.4 megacycles, there is a 0.4-megacycle difference from the lower crystal check point. The number obtained in step <i>e.</i> was 30. Therefore $30 \times .4 = 12$ . This is the number of dial divisions above the lower crystal check point where the desired frequency is located.
<i>g.</i> Add number obtained in step <i>f.</i> to numerical setting for lower check point as obtained in step <i>b.</i>	<i>g.</i> Numerical setting for lower check point was 756; desired frequency is 12 dial divisions above this, or $756 + 12 = 768$ . See figure 4-2.
<i>b.</i> Set index scale (E108) and TUNING knob vernier at the value obtained in step <i>g.</i> The signal generator is now tuned to the desired frequency; accuracy is $\pm 0.05$ percent on frequencies above 15 megacycles.	

(5) Adjust SET RF OUTPUT control (E101) until meter reads in the red arc of the scale (full scale deflection).

(6) If frequency desired coincides with one of the crystal check points (spaced at 1-megacycle intervals from 1 to 50 megacycles), adjust TUNING knob slightly until zero beat is heard in the headphones. The signal generator is now tuned properly at a crystal check point. If the desired frequency falls *between* crystal check points, follow the procedure given in Table 4-2.

**Note**

For greatest accuracy, always approach the selected frequency by rotating the TUNING knob (E107) in a clockwise direction. This eliminates errors due to gear assembly backlash.

**6. ADJUSTING OUTPUT VOLTAGE.**

*a. PRELIMINARY SETTINGS.* Before the output voltage is adjusted, the signal generator control should be set in the following positions:

(1) Turn SET RF OUTPUT and % MOD controls fully counterclockwise.

(2) Plug power cable into power receptacle.

(3) Throw POWER switch to ON position. Allow 15-minute warm-up period.

(4) Set FUNCTION SWITCH to CW position.

(5) Turn MICROVOLTS control fully clockwise.

(6) Turn BAND SWITCH to desired frequency range, and set exact frequency desired on main tuning dial. (See paragraph 3.) If extreme accuracy is required, follow procedure described in paragraph 5.

*b. ADJUSTMENTS.*

(1) Turn the SET RF OUTPUT control in a clockwise direction until the meter reads in the red arc of the scale.

(2) When using RF OUTPUT jack, select the attenuation range with the RF STEP ATTENUATOR knob and adjust the MICROVOLTS control for the desired output voltage. The microvolt scale to be used on the meter depends upon the position of the attenuator knob. For example, in the 100K or 10K position

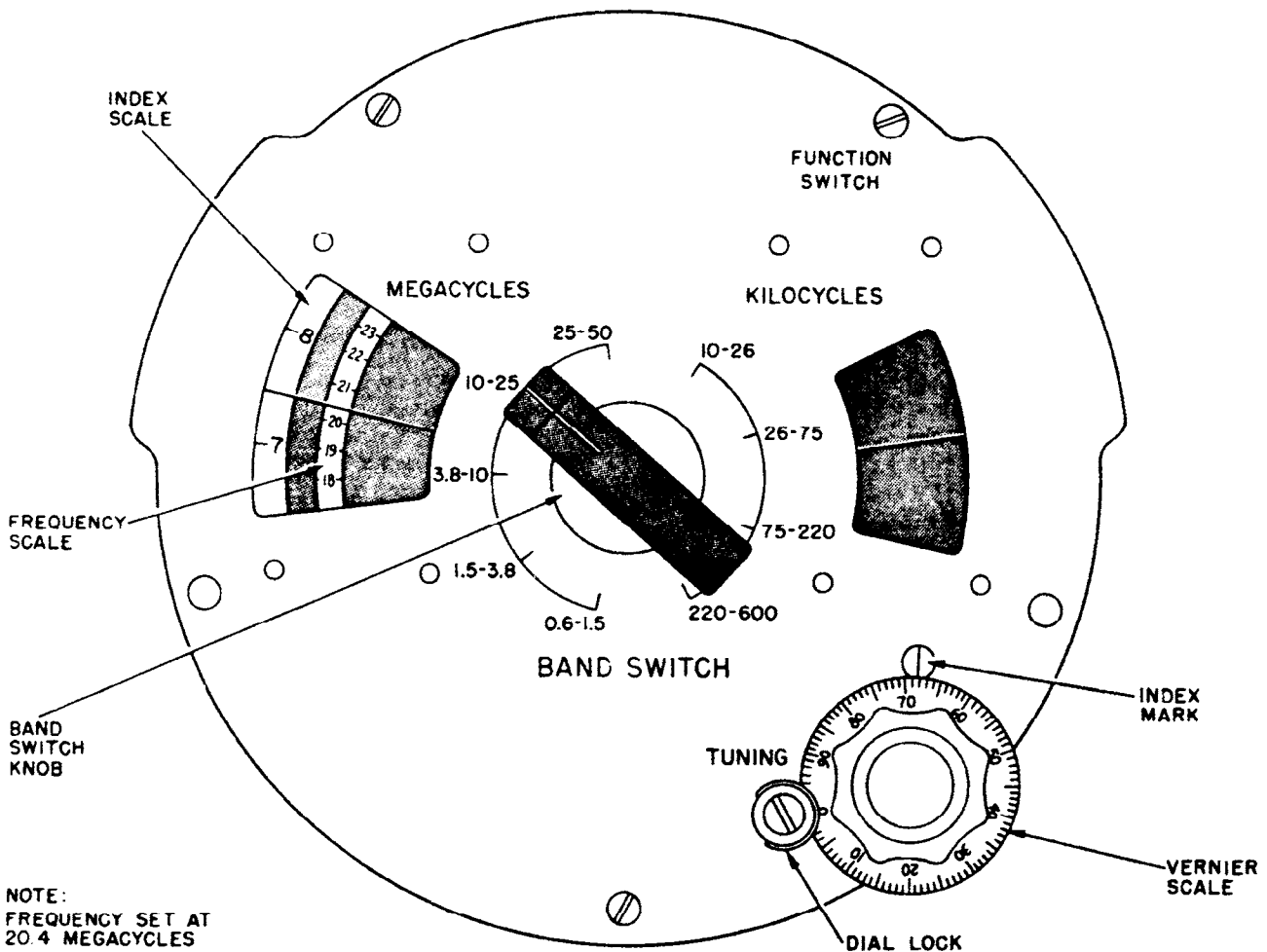

Figure 4-2. Frequency, Index Vernier Scales

use the top microvolts scale and on the 30K or 3K position use the lower microvolts scale. The output in microvolts shown by the attenuator step position is obtained when the meter reading is on 10 when using the upper microvolts scale and 3 when using the lower microvolts scale.

(3) For output voltages between attenuator step positions adjust the MICROVOLTS control knob to the appropriate meter reading. For example, to obtain 600 microvolts set the step attenuator to 1K position, and adjust MICROVOLTS control until meter reads 6 on upper microvolts scale. The meter reading is accurate only if the signal generator is terminated in 50 ohms.

(4) When changing frequency, it is necessary to reset the SET RF OUTPUT control. Rotate MICROVOLTS control fully clockwise and readjust SET RF OUTPUT control until meter reads in the red arc of the scale. Set desired output voltage as described in steps 2 and 3. Do not use the SET RF OUTPUT control for this purpose.

(5) When using the HIGH RF OUTPUT jack (J101) signal level is set by the MICROVOLTS control. The RF step attenuator does not affect the voltage at this jack. When the SET RF OUTPUT control (E101) is set up in step (1), the open-circuit voltage at J101 will be 2 volts. Use the MICROVOLTS control to reduce the amplitude further.

**TABLE 4-3. RF ATTENUATOR CALIBRATIONS**

**Note**

These calibrations hold only when signal is terminated into 50 ohms and the SET RF OUTPUT control is set as described in steps 1 and 2 of this paragraph.

STEP	VOLTAGE OUT (microvolts)	LOSS IN DECIBELS
1	100,000	0
2	30,000	10
3	10,000	20
4	3,000	30
5	1,000	40
6	300	50
7	100	60
8	30	70
9	10	80
10	3	90
11	1	100
12	0.3	110

**7. INTERNAL MODULATION AND AUDIO OUTPUT.**

*a.* INTERNAL MODULATION.

(1) Follow the procedure described in paragraph 6.

(2) Set % MOD control fully counterclockwise.

(3) Set FUNCTION SWITCH to 400 or 1000 INT MOD position as desired.

(4) Adjust % MOD control until meter reads the desired percentage of modulation. Modulation percentages between 30 or 50 percent are indicated to an accuracy of  $\pm 10$  percent.

*b.* AUDIO OUTPUT (400 or 1000 cycles).

(1) Follow steps 2, 3, 4 for internal modulation, omit step 1.

(2) Audio voltage proportional to the reading on the meter is available at the AUDIO OUT jack. Maximum open-circuit voltage is 6 volts.

(3) Terminate audio testing signals into high impedance equipment (100,000 ohms or greater) to prevent loss of output voltage.

**8. EXTERNAL MODULATION.**

*a.* Follow the procedure described in paragraph 6.

*b.* Turn % MOD control fully counterclockwise.

*c.* Set the FUNCTION SWITCH (E103) to EXT MOD position.

*d.* Connect an external audio frequency source to the EXT MOD IN jack (J104).

*e.* Adjust % MOD control (E104) for desired percentage of modulation on meter.

*f.* Modulation frequencies between 100 and 1000 cycles only are to be used at carrier frequencies below 300 kilocycles. Above 300 kilocycles, modulation frequencies can be between 100 and 15,000 cycles.

*g.* The accuracy of indicated percentage of modulation is  $\pm 1.5$  db. between 100 and 10,000 cycles.

**9. TERMINATING THE SIGNAL GENERATOR.**

*a.* When the 50-ohm cable assembly CG-409A/U is plugged into the RF OUTPUT jack (J102) and terminated properly (50 ohms), no standing waves will be present. Impedance Matching Unit CU-406/URM-25F, described in paragraph 2-12, is supplied with the equipment. When the receiver input impedance is at least 10 times the generator output impedance (e. g. approximately 500 ohms or greater), the impedance matching unit is connected between the signal generator and receiver to maintain proper termination. A 6-inch cable assembly, CG-409/U, is used to connect the matching unit to the receiver; the 4-foot cord is used to connect the signal from the signal generator to the termination unit. When connections are made as described all meter readings are correct.

*b.* When the receiver input impedance is less than 50 ohms, the impedance adapter cannot be used. In this case, a non-inductive resistor should be added in series so that the sum of the receiver input impedance and the resistor will be 50 ohms. The total impedance will then match the signal generator at the RF OUTPUT jack (J102) and standing waves will be eliminated. The

actual receiver input voltage can then be calculated from the following formula.

$$\text{Volts} = \frac{50 \text{ ohms-series resistor in ohms}}{50} \times \text{volts}$$

indicated. For example, if the receiver input impedance is equal to 30 ohms, a series resistor of 20 ohms must be added to match the 50-ohms signal generator. A meter reading of 10,000 microvolts will then represent an actual receiver input voltage as follows.

$$\text{Volts} = \frac{50 - 20}{50} \times 10000$$

$$6000 = 30 \times 200$$

The actual voltage at receiver terminals is 6000 microvolts. To minimize leakage and other losses, the series resistor should be inserted as close as possible to the receiver input terminals.

c. If the receiver input impedance is considerably less than 500 ohms, but more than 50 ohms, the impedance adapter is replaced by a non-inductive shunt resistor. This resistor shunts the receiver input impedance and brings down the total impedance to 50 ohms. The actual receiver input voltage is then equal to the meter reading. For example, if the receiver input impedance is 120 ohms, select the correct shunt resistor by the formula

$$\frac{\text{receiver impedance} \times 50 \text{ ohms}}{\text{receiver impedance} - 50 \text{ ohms}}$$

$$\frac{120 \times 50}{120 - 50}$$

$$\frac{6000}{70} = 85.07 \text{ ohms}$$

d. When the input impedance of the receiver is 70 ohms as is the case with most Navy receivers, the signal generator is properly terminated by using the Impedance Matching Network CU-408/URM-25F. This network has different input and output connectors. The output connector of the CU-408 adapter matches the input connector for Navy receivers, and should be connected directly to the receiver input if possible. The input of the adapter is connected to the signal generator by means of the 4-foot cable W-102. This results in a completely matched system. Refer to paragraph 2-13 for circuit description. Since the actual voltage at the receiver terminals is reduced by 20 decibels, a factor of 10, it can be calculated as follows.

$$\text{Actual volts} = \frac{\text{indicated volts}}{10}$$

For example assume a meter indication of 100 microvolts.

$$\text{Receiver volts} = \frac{100}{10} \text{ or } 10 \text{ microvolts.}$$

## 10. COUPLING TO RECEIVER UNDER TEST.

a. RF OUTPUT jack (J102). For best results, the termination principles outlined in Tables 4-4 and 4-5 should be followed when using 50-ohm output from J102. Cords CG-409 A/U are provided for making the necessary connections between accessory units and receivers under test.

b. HIGH RF OUTPUT jack (J101). The impedance at this jack is a resistance of 500 ohms shunted by a capacitance of 6 micromicrofarads. Additional capacity is added when a cable is connected. Therefore, the output voltage will depend on frequency of operation and length of cable. In any event, a minimum of 1 volt is available at J101 for all frequencies. It is reemphasized at this point that the termination methods outlined in Table 4-5 do not apply to this jack since the impedance at J101 is 500 ohms.

### CAUTION

Care must be taken to prevent the introduction of voltages back into the attenuators or impedance adapters from the circuit under test. Currents greater than 25 milliamperes may burn out resistances within these units. Always insert Test Lead CX-2919/U whenever making point-to-point measurements in a receiver. This precaution is not necessary when using the Dummy Load, Electrical DA-109/URM-25F, which contains a series capacitor.

c. Tables 4-4 and 4-5 show the most desirable type of termination for any particular receiver input impedance.

TABLE 4-4. TERMINATION REFERENCES

RECEIVER IMPEDANCE	METHOD	PARAGRAPH
Less than 50 ohms	Series resistor	8b
50 ohms to approximately 500 ohms	Parallel resistor	8c
500 ohms or greater	Impedance Matching Unit CU-406/URM-25F	8a
70 ohms	Impedance Matching Unit CU-408/URM-25F	8d

## 11. USE OF ELECTRICAL DUMMY LOAD DA-109/URM-25F. (See figure 4-3.)

a. Dummy Load DA-109/URM-25F is used in making overall measurements or tests on a receiver designed for use with a standard antenna. The dummy load approximates the conditions that would exist had the signal been applied to the antenna circuit of the receiver. Therefore, the significant voltage is the input

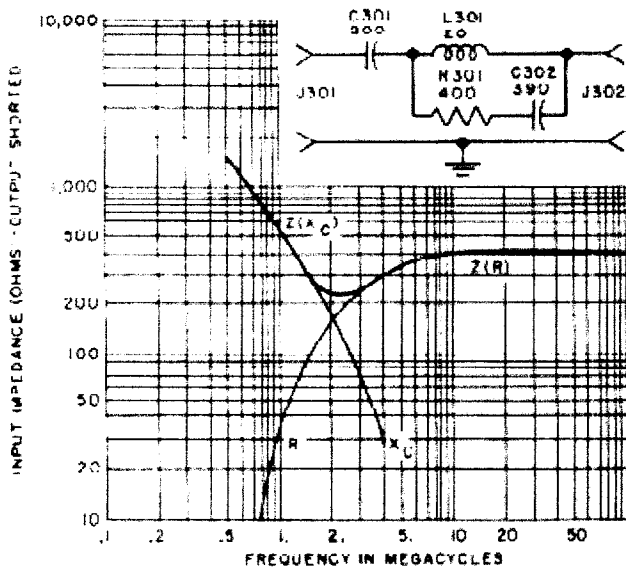

Figure 4-3. Dummy Load Impedance Curve

voltage to the dummy load rather than the input voltage to the receiver.

b. Connect a cord to the RF OUTPUT jack (J102) and terminate this cable with Impedance Matching Network CU-406/URM-25F. Connect the dummy load to the impedance matching network with a short length of cord and to the receiver under test with another short cord.

c. It can be seen from figure 4-3 that the minimum impedance of the dummy load will be approximately 220 ohms at 2 megacycles. This impedance becomes much higher at lower frequencies and approaches 400 ohms at higher frequencies. When using the dummy load, it should be realized that a 20 percent maximum error may be introduced into the meter (M101) readings at 2 megacycles. If greater meter accuracy is required, the actual impedance of the dummy load should be determined from figure 4-3 at the frequency selected. For example, if the output frequency of the signal generator is 20 megacycles, it can be seen from figure 4-3 that the series impedance of the dummy load is approximately 400 ohms resistive. A meter indication of 10,000 microvolts then represents the input voltage to the dummy load.

d. It should be realized that the input voltage to the dummy load is of far greater significance than the output voltage. This is because the dummy load, in simulating a standard antenna, becomes an integral part of the receiving system and is essential in giving a true picture of the overall sensitivity of the receiver under test.

e. For an accurate indication of the receiver output voltage, the impedance of the dummy load in series with the impedance of the equipment under test should total at least 500 ohms. From figure 4-3 it is apparent that the accuracy will be sufficiently good at frequencies above 5 megacycles. Below 5 megacycles, dummy load impedance falls approximately 220 ohms; to main-

tain accuracy at these frequencies, the receiver under test should exhibit an input impedance of at least 280 ohms.

## 12. USING THE SIGNAL GENERATOR.

a. OPERATING CONTROLS. A list of the front panel controls and their function is given in Table 4-1. The following paragraphs provide a concise summary of standard testing procedures utilizing a Signal Generator AN/URM-25F. Additional signal testing techniques will be found in the instruction book for the equipment under test.

### CAUTION

Always use Test Lead CX-2919/U when making point-to-point tests on a receiver. Failure to do so may result in burning out a resistor in the step attenuator or in one of the accessory units.

### b. RECEIVER TESTS

(1) GENERAL. The presence of incidental frequency modulation in an AM signal generator may introduce asymmetry in the apparent selectivity curve of the receiver being tested. This is particularly true for very sharply-tuned circuits. The effects of frequency modulation have been kept to a minimum in RF Signal Generator AN/URM-25F and should introduce no problem in receiver testing. For best results, perform all of the following receiver tests (except audio response) by using the unmodulated carrier signal. To do this, connect a high-impedance DC voltmeter such as Multimeters ME-25/U, AN/USM-34, or equivalent across the load of the second detector of the receiver. Adjustments can be then made with the meter deflection giving the necessary indication.

(2) SENSITIVITY. At high radio frequencies, antenna characteristic cannot be easily reproduced, and considerable care must be taken in making receiver sensitivity tests. The voltage available at the signal generator output jack (J102) is always known, but it is not known at the receiver terminals a few feet away. This latter voltage is proportional to the signal generator output voltage, but may be larger or smaller due to the characteristics and termination of the "transmission line" between the signal generator and the receiver under test.

(3) SELECTIVITY. The selectivity of a radio receiver is its ability to distinguish between the desired signal and signals at other frequencies. Selectivity is normally obtained by disabling the automatic volume control system of the receiver, setting the signal generator to the desired frequency, tuning the receiver to this frequency, and modulating the carrier signal 30 percent at 400 cycles. The frequency of the carrier is then varied in steps on either side of the frequency to which the receiver is tuned. The signal generator voltage is adjusted as necessary to maintain a constant receiver output. This information is plotted on a graph

of signal generator output (in decibels) versus frequency. The selectivity curve so obtained is compared with the curve specified by the equipment instruction book.

(4) AUDIO RESPONSE. The audio response of a receiver shows the manner in which the electrical output depends upon the modulation frequency. In making this test, connect a variable audio oscillator, such as the Navy Model AN/USM-30, TS-382/U Series or equivalent, to the EXT MOD IN jack (J104). Replace the receiver loudspeaker with an equivalent resistance. Connect an output meter across this resistance. Set the FUNCTION SWITCH (E103) to the EXT MOD position. Set the signal generator to the desired carrier frequency and tune the receiver under test to this frequency. Adjust the signal generator until a convenient output is obtained at 400 cycles. This will be the reference against which all other measurements will be compared. Observe the variation in receiver output as modulation frequencies are varied, while keeping the degree of modulation constant at 30 percent. The result of an audio response test are expressed in the form of a curve with the ratio

output at frequency

output at 400 cycles

plotted vertically, and each corresponding audio frequency plotted horizontally. In making this test, avoid overloading the receiver with excessive signal. If the noise and hum level in the receiver output are appreciable, increase signal strength from the generator until it overrides this interference.

(5) MEASURING RECEIVER GAIN PER STAGE. RF Signal Generator AN/URM-25F is also a useful device for measuring the gain of stage. To do this, connect a VTVM as the ME-74/U, ME-6/U or equivalent (with decibels scale) to the output of the stage. Apply signal generator to output of stage and increase signal strength until meter reads on upper portion of scale. Note reading. Move signal generator to input of stage and note difference from the previous reading. This difference, expressed in decibels, represents the gain of the stage.

(6) RECEIVER ALIGNMENT. The alignment of the intermediate-frequency amplifier system of a simple receiver is usually carried out by setting up the signal

TABLE 4-5. TERMINATION METHODS

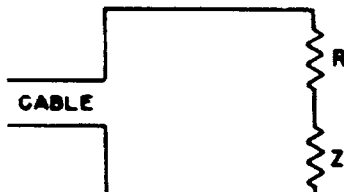
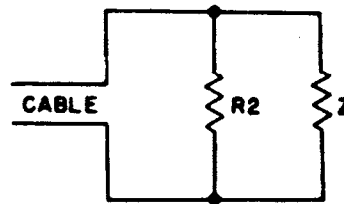
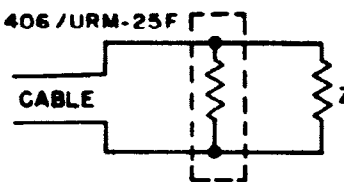
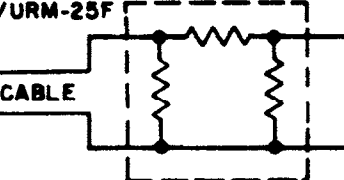
RECEIVER IMPEDANCE	CIRCUIT	ACCESSORY RESISTORS	VOLTAGE AT RECEIVER IS:
Less than 50 ohms ( $Z_1$ )		$R_1 = 50 - Z_1$	$V_{\text{indicated}} = \frac{Z_1}{50}$
From 50 ohms to approximately 500 ohms ( $Z_2$ )		$R_2 = \frac{50 Z_2}{Z_2 + 50}$	$V_{\text{indicated}}$
500 ohms or more ( $Z_3$ )	CU-406 / URM-25F 	IMPEDANCE ADAPTER	$V_{\text{indicated}}$
70 ohms ( $Z_4$ )	CU-408 / URM-25F 	IMPEDANCE ADAPTER	$\frac{V_{\text{indicated}}}{10} =$

generator at the proper frequency and working step by step backwards through the IF circuits from the second detector to the first detector.

### CAUTION

Consult the particular receiver's instruction book for details of the method applicable to that receiver. This is particularly important for wide-band amplifiers when over coupled, regenerative or stagger tuning is used. Be sure the aligning frequency is correct. Check with a heterodyne frequency meter such as AN/USM-29, AN/URM-82 series to obtain greater frequency accuracy than obtainable with a signal generator below 1 megacycle. Above 1 megacycle, the crystal calibrator in the AN/URM-25F can be used to obtain an accuracy within 0.05 percent.

Always apply the signal generator to the grid immediately preceding the circuit under adjustment and adjust the trimmers (or variable inductances) for maximum output. In carrying out this procedure, it will of course be necessary to reduce the output of the signal generator each time the signal is applied to the grid of a tube at lower power level. The next step is to align the radio frequency and oscillator circuits of the receiver. This is accomplished by setting the receiver dial near the high end of the band in question and applying a signal of the proper frequency from the signal generator to the antenna input terminals of the receiver. First adjust the RF stage shunt trimmer capacitors (or iron core inductances) for maximum receiver output, and then adjust the oscillator shunt trimmer until receiver output is maximum. The receiver dial and signal generator are then set at the low frequency end of the receiver dial, and the oscillator series padder capacitor is adjusted for maximum output. Recheck the high frequency end of the band and repeat the above procedure as necessary.

(7) RECEIVER ALIGNMENT ABOVE 50 MEGACYCLES. RF Signal Generator AN/URM-25F can also be used to align receivers above 50 megacycles by using the second harmonic of the frequency selected. Although the harmonic distortion is kept below 10 percent this still allows some second harmonics to be introduced at the RF OUTPUT jack (J102). However, when the second harmonic is used, the signal generator meter can no longer be used as an indication of output.

c. MODULATED OPERATION. In using the equipment with modulated output, three waves are emitted, one at the carrier frequency and one at each of the two "sidebands." Considerable discretion must be used in employing the modulated method of receiver testing, based on the selectivity of the receiver and frequency of test, since the carrier and both side-

bands must be received in true proportion in order to obtain accurate measurements.

d. RECEIVER OUTPUT. In aligning or testing a receiver, a voltmeter or output meter should be connected across the output terminals, in parallel with the proper resistance output load.

e. RECEIVER OVERALL SENSITIVITY. The sensitivity of some radio receivers is so high that at certain frequencies the inherent noise level is sufficient to saturate the detector or audio tubes. Accordingly, all receivers are measured and rated for both CW and MCW sensitivity with their sensitivity, volume, and gain controls adjusted so that under no-signal conditions no more than 60 microwatts of noise is present in the output. When reading overall receiver sensitivity it may not be possible to attenuate all frequencies to zero, even when the ATTENUATOR knob (E102) is set at 0.3 microvolt and the MICROVOLTS control (E105) is fully counterclockwise. This is due to the effects of leakage and stray disturbances caused by circulating currents in the case, or between panel and case. These effects can be minimized by properly orienting the signal generator with respect to the receiver. Proper orientation of the signal generator will also minimize pickup of unwanted external voltages. To determine whether interference is due to signal generator leakage or to outside pickup, compare the output of the receiver with the signal generator turned ON and the output with the generator OFF.

f. STANDARD LEVELS. Standard levels are as follows:

- (1) Standard output level of reference - 6 milliwatts.
- (2) Standard noise level - 60 microwatts.
- (3) Standard output load - 600 ohms for low impedance output, or 20,000 ohms for high impedance output, unless special impedances are provided in receivers and noted in their instruction books.

g. VOLTMETER USED AS AN OUTPUT METER. In making measurements using a voltmeter as an output meter, the following approximate wattages correspond to the voltages at the load impedances noted:

- (1) 1.9 volts at 600 ohms  
11.0 volts at 20,000 ohms                      6 milliwatts
- (2) 0.19 volt at 600 ohms  
1.1 volts at 20,000 ohms                      60 microwatts
- (3) 0.77 volt at 600 ohms  
4.5 volts at 20,000 ohms                      1 milliwatt
- (4) For receivers provided with output meters having a zero level of 6 milliwatts - minus 20 decibels equal 60 microwatts.
- (5) For receivers provided with output meters having a zero level of 60 microwatts - plus 20 decibels equal 6 milliwatts.



## SECTION 5 OPERATOR'S MAINTENANCE

### 1. GENERAL.

a. The RF Signal Generator AN/URM-25F is capable of producing accurate test signals when properly calibrated and maintained. Therefore, maintenance procedure performed by non-technical operators necessarily must be limited to replacing fuses and pilot lamp and keeping an operations and measurements record to aid maintenance personnel in trouble shooting the equipment.

### 2. ROUTINE CHECK CHART. (Refer to figure 4-1.)

Before using the equipment perform the checks listed in Table 5-1, "Routine Check Chart."

### 3. FUSE REPLACEMENT.

If equipment stops operating, check for symptoms of fuse failure per Table 5-2. If equipment exhibits these

symptoms, refer to Table 5-3 for fuse locations. In replacing fuses, obey the following precautions:

#### CAUTION

Never replace a fuse with one of higher rating unless continued operation of the equipment is more important than probable damage. If a fuse burns out immediately after replacement, do not replace it a second time until cause of failure has been corrected.

### 4. INDICATOR LAMP.

The power-on lamp, I103, is located in the lower left hand corner of the front panel. To remove lamp, unscrew jewel and remove; press down on lamp, turn counterclockwise, and pull out. Replace with Navy type TS-53 lamp.

**TABLE 5-1. ROUTINE CHECK CHART**

WHAT TO CHECK	HOW TO CHECK	PRECAUTIONS AND REMARKS
1. Installation	<p>Before connecting the power cable to the power source, make sure the equipment is properly set up in accordance with instructions given in Section 3—INSTALLATION.</p> <p>a. POWER switch (S102) in OFF position.</p> <p>b. Set RF OUTPUT control (E101) fully counterclockwise.</p> <p>c. % MOD control (E104) fully counterclockwise.</p> <p>d. MICROVOLTS control (E105) fully clockwise.</p>	See that all the cables and wires are in good condition and that electrical connections are properly made.
2. Power Supply	<p>Set controls as follows:</p> <p>a. Set RF OUTPUT control (E101) fully counterclockwise.</p> <p>b. % MOD control (E104) fully counterclockwise.</p> <p>c. POWER switch (S102) to ON position.</p>	The indicator lamp (I103) and frequency scale lamps (I101) (I102) should light. If they do not, check front panel fuses (see Table 5-3) and lamps.
3. Carrier Frequency	<p>Set the controls and switches as follows:</p> <p>a. Set RF OUTPUT (E101) fully counterclockwise.</p> <p>b. MICROVOLTS control (E105) fully clockwise.</p>	<p>a. Meter (M101) should move up-scale as SET RF OUTPUT control (E101) is rotated in a clockwise direction.</p> <p>b. The meter pointer should be able to be adjusted into the red arc of the meter scale in all positions of the BAND SWITCH (E106).</p>

TABLE 5-1. ROUTINE CHECK CHART (Cont'd)

WHAT TO CHECK	HOW TO CHECK	PRECAUTIONS AND REMARKS
3. (Cont'd)	<ul style="list-style-type: none"> <li>c. FUNCTION SWITCH (E103) to the CW position.</li> <li>d. BAND SWITCH (E106) to corresponding band position.</li> <li>e. POWER switch (S102) to ON position.</li> </ul>	
4. Modulation Frequency	Set controls and switches as follows: <ul style="list-style-type: none"> <li>a. Set RF OUTPUT control (E101) fully counterclockwise.</li> <li>b. % MOD control (E105) fully counterclockwise.</li> <li>c. FUNCTION SWITCH (E103) to INT MOD 400 cycle position.</li> <li>d. BAND SWITCH (E106) to corresponding band position.</li> <li>e. POWER switch (S102) to ON position.</li> </ul>	When % MOD control (E104) is rotated clockwise, the meter should reach a minimum of 50 percent modulation as indicated on meter scale.

TABLE 5-2. SYMPTOMS OF FUSE FAILURE

POWER "ON" PANEL LAMP (I103) AND DIAL SCALE LAMPS (I101 AND I102)	ALL ELECTRON TUBES	METER M101	OPEN FUSE	VALUE (AMPS)	COMMENTS
NONE LIGHT	HEATERS OUT	NO READINGS	F101 or F102 or BOTH	1.5 each	Check power cable from signal generator to power supply.

TABLE 5-3. FUSE LOCATIONS

FUNCTIONAL SYMBOLS	LOCATION	PROTECTS	FUSE RATING
F101 AND F102	<ul style="list-style-type: none"> <li>1. Physically located on signal generator front panel in fuse holders (XF101 and XF102). See figure 4-1.</li> <li>2. Electrically located in primary of power transformer T601. See figure 2-14.</li> </ul>	Primary of power transformer (T601)	1.5 amps each

## SECTION 6 PREVENTIVE MAINTENANCE

THE ATTENTION OF MAINTENANCE PERSONNEL IS INVITED TO THE REQUIREMENTS OF CHAPTER 67 OF THE BUREAU OF SHIPS MANUAL OF THE LATEST ISSUE.

### 1. ROUTINE MAINTENANCE CHECK CHART.

The fully-enclosed construction of RF Signal Generator AN/URM-25F minimizes the extent of preventive maintenance. Periodic testing of equipment to determine if it is in proper working order should be performed in accordance with the step-by-step procedure given in Table 5-1, "Routine Check Chart." If the signal generator is used frequently (several times a week), these checks should be made prior to use. Otherwise

they can be made weekly. Unless otherwise specified, all symbol designations given in Table 5-1 refer to the front panel diagram of figure 4-1.

### 2. LUBRICATION DATA.

Lubrication in the Signal Generator AN/URM-25F is required on the tuning capacitor worm gear and worm of the tuning drive assembly. The parts are to be lubricated once a year. Apply a thin film of MIL-G-3278 grease on the surfaces of the worm and gear. Rotate the worm and gear several times to spread lubricant evenly. Remove old grease and clean parts before applying new lubricant.

**TABLE 6-1. LUBRICATION DATA**

LUBRICANT		
ANA SPECIFICATION	DESCRIPTION	FEDERAL STOCK NO.
MIL-G-3278	Grease, Aircraft Instruments, for low and high temperatures	8 oz tube, WS-9150-261-8297 1 lb can, WS-9150-261-8298 5 lb can, WF-9150-223-4012 25 lb can, WR-9150-190-0897 35 lb can, WF-9150-190-0898 100 lb can, WS-9150-190-0899

## FAILURE REPORTS

**A** FAILURE REPORT must be filled out for the failure of any part of the equipment whether caused by defective or worn parts, improper operation, or external influences. It should be made on Failure Report, form NAVGEN 1025, which has been designed to simplify this requirement. The card must be filled out and forwarded to BUSHIPS. Full instructions are to be found on each card.

Use great care in filling the card out to make certain it carries adequate information. For example under "Circuit Symbol" use the proper circuit identification taken from the schematic drawings, such as T-803, in the case of a transformer, or R-207, for a resistor. Do not substitute brevity for clarity. Use the back of the card to completely describe the cause of failure and attach an extra piece of paper if necessary.

The purpose of this report is to inform BUSHIPS of the cause and rate of failures. The information is used by the Bureau in the design of future equipment and in the maintenance of adequate supplies to keep the present equipment going. The cards you send in, together with those from hundreds of other ships, furnish a store of information permitting the Bureau to keep in touch with the performance of the equipment of your ship and all other ships of the Navy.

This report is not a requisition. You must request the replacement of parts through your Officer-in-Charge in the usual manner.

Make certain you have a supply of Failure Report cards and envelopes on board. They may be obtained from the nearest District Printing and Publication Office.

Figure 7-1. Failure Reports

## SECTION 7 CORRECTIVE MAINTENANCE

### 1. THEORY OF LOCALIZATION.

a. The first step in maintenance or repair is to determine definitely that a defective condition exists. If the equipment is not operated correctly, certain indications of trouble might be presented when there is actually nothing wrong with the equipment. The technician should be thoroughly familiar with Section 4, OPERATION, of this book before attempting to analyze the indicated defect.

b. After positive determination is made that the generator is defective, the first step in trouble shooting is to localize the trouble, that is, decide which circuit of the signal generator is not functioning. Once the analysis has narrowed down to the defective circuit, it becomes a relatively simple process of making voltage and resistance checks to locate the faulty part (e.g. resistor, capacitor, etc.).

c. The chief parts of the signal generator which are subject to wear or deterioration are electronic tubes and switches. In addition the RF oscillator inductances may vary slightly and require recalibration as a result of aging or excessive temperature variations. (See Table 7-1 FREQUENCY CALIBRATION DATA.)

### 2. TEST EQUIPMENT FOR TROUBLE SHOOTING.

The technician may find a wide variation of applicable test equipment to use in trouble shooting and making repairs on the RF Signal Generator AN/URM-25F. However, to achieve the best results in accordance with the characteristics of the signal generator, the following test equipments or their equivalents are recommended for use:

a. Navy Model AN/URM-82 Crystal Calibrated Frequency Indicating Equipment.

b. Navy Model AN/USM-29 Combined Heterodyne Frequency Meter and Crystal Controlled Calibration Equipment.

c. Tube Tester TV-3/U or equivalent.

d. Electronic Multimeter ME-74/U or ME-6/U Series.

e. Resistance Bridge ZM-4/U.

f. Oscilloscope OS-8/U, Series AN/USM-32 or equivalent Cathode Ray Oscilloscope.

g. Multimeter AN/PSM-4, TS-352/U.

### 3. SYSTEM TROUBLE SHOOTING.

a. In employing any systematic method for trouble shooting, the methods and procedures followed by the technician will vary greatly. Any method employed is satisfactory as long as it will produce accurate results with greatest expediency.

b. To assist the electronics technician in applying himself to the maintenance problems, a trouble symptoms chart and two trouble shooting tables are listed in this section. The first, Table 7-2, TROUBLE SYMPTOM CHART is a listing of some common trouble symptoms with suggested checks for locating the defect; the second, Table 7-3, TROUBLE LOCALIZATION CHART is a systematic procedure for determining the defective unit or component; the third, Table 7-4, SPECIFIC TROUBLE TEST CHART gives hints that may be applied in finding the specific part that may be defective.

### 4. TUBE OPERATING VOLTAGES AND CURRENTS.

Electron tube operating voltages and currents under normal operating conditions are given in Table 7-5, TUBE OPERATING VOLTAGES AND CURRENTS.

### 5. RESISTANCE MEASUREMENTS.

A complete set of resistance readings from the tube sockets of the AN/URM-25F is given in Table 7-6, RESISTANCE MEASUREMENTS.

### 6. INTERIOR AND EXTERIOR VIEWS OF UNITS.

To assist the technician doing maintenance work in locating the positions of various coils, capacitors, resistors, switches, etc., comprising the signal generator, there will be found in this section additional photograph illustrations. They show the parts of the signal generator with the corresponding symbol designation indicated. These pictures will facilitate the easy and quick identification of all parts.

### 7. REMOVING THE SIGNAL GENERATOR FROM THE CASE. (See figure 7-2.)

a. Since the RF Signal Generator AN/URM-25F is a precision instrument, great care should be taken in removing the signal generator from its case. Before attempting to disassemble the unit, be sure that the power cord is disconnected from the power source. Adhere carefully to the following procedure:

(1) Loosen the six captive screws located around the outer edge of the panel. See figure 7-2.

(2) Gently pull the signal generator chassis about eight inches from the cabinet, using the lifting handles provided on the front panel. The generator unit cannot be completely removed since the interconnecting power cable is still connected to the power supply.

(3) Remove the power supply cable by pulling the power plug out of the power supply socket on the power supply sub-chassis. The generator may now be

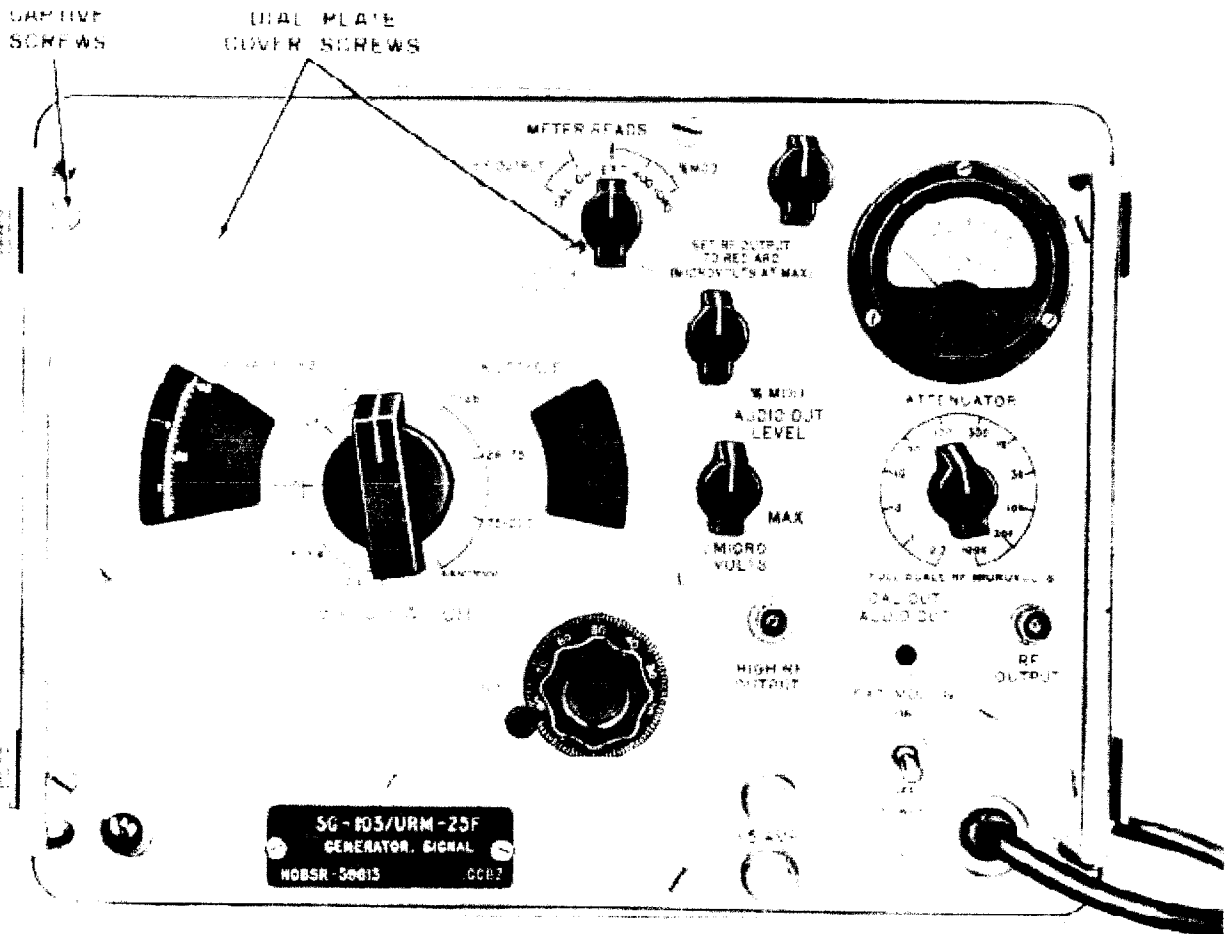

Figure 7-2. RF Signal Generator AN/URM-25F Front Panel

removed. The power supply will remain in the cabinet and *cannot* be removed.

(1) With signal generator removed from the case, the equipment may now be reconnected for testing purposes. Enough power cable is provided to enable the signal generator to be connected to its power supply when out of its case.

(a) Insert power supply cable plug (P104) into power supply socket (P601).

(b) Insert power cable into power line. The unit may now be turned on for testing procedures.

### WARNING

Voltages up to 400 volts will be exposed when the signal generator is being tested outside of the cabinet. Exercise great care in handling the instrument under these conditions.

### 8. REMOVAL OF RF SHIELD ASSEMBLY.

a. Procedure.

(1) Place signal generator chassis face down and

allow the chassis to rest on front panel handles.

(2) Locate the four RF shield latches. (See figure 7-3.)

(3) Depress and rotate each latch through 90°.

(4) Release latch.

(5) Remove the shield assembly by lifting straight up.

b. Reassembly Precautions and Instructions.

When replacing the RF shield assembly be sure the red indicator line on the RF shield assembly lines up with red arrow on the front panel casting. The arrow is located below the RF oscillator tube V101. The RF shield assembly must not be tilted and the shield should fit snugly in the taper provided in the front panel. (See figure 7-6.) Failure to properly position the shield will prevent reassembly.

### 9. REMOVAL AND REPLACEMENT OF PARTS.

a. Whenever repairs are made involving the removal or replacement of any component part, the part removed should be marked or tagged for identification and its

exact position in the equipment carefully noted and recorded so that when the same or new part is replaced the equipment will be precisely as before. This precaution is particularly necessary when RF components such as coils and capacitors are replaced. The location of these parts with respect to associated components plays an important role in the performance of the equipment.

b. Whenever any parts are replaced by new ones always use the identical type listed and described in Section 8, Table 8-1. If such parts cannot be obtained, substitute only similar parts with equivalent electrical and mechanical characteristics. This is not recommended as a normal procedure and the exact replacement should be ordered.

c. Replacement of the majority of parts in the RF Signal Generator AN/URM-25F usually does not require a disassembly of the signal subassemblies, since

construction is such that most components are exposed. Therefore, removal instructions of subassemblies are limited.

#### 10. DISASSEMBLY OF STEP ATTENUATOR.

(See figure 7-4.)

##### a. Procedure.

(1) Remove the signal generator from its case. See paragraph 7.

(2) Position the signal generator chassis face down and allow it to rest on the front panel handles.

(3) Locate detent assembly (E135).

(4) Loosen the detent collar screws (E136).

(5) Remove two detent holding screws and spacers (E137).

(6) Lift off detent.

(7) Remove three cover holding screws.

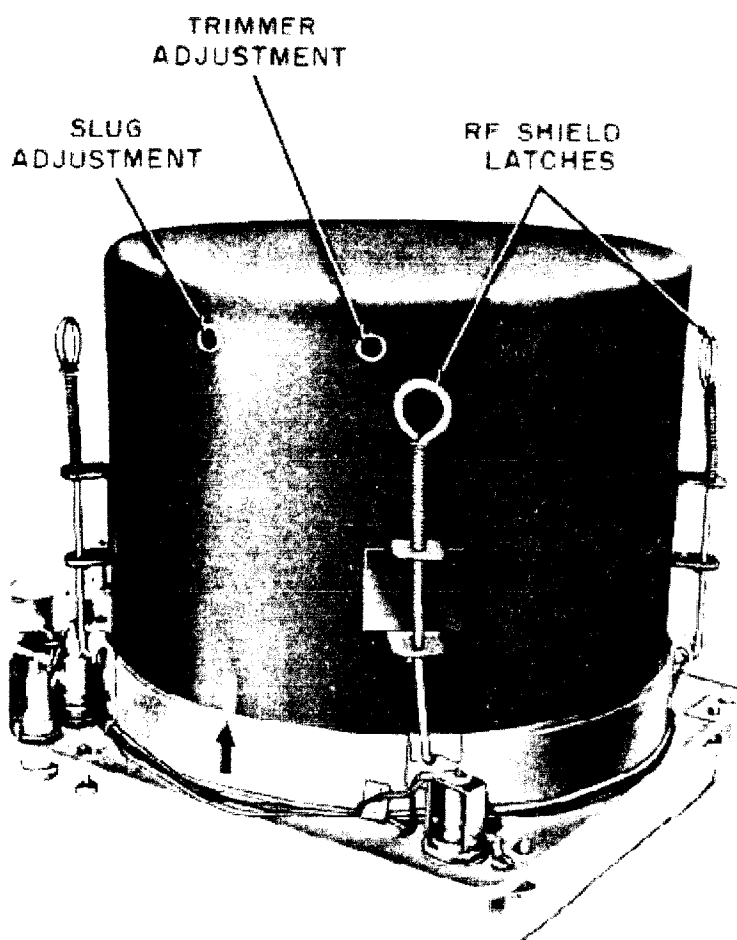

Figure 7-3. RF Shield Assembly

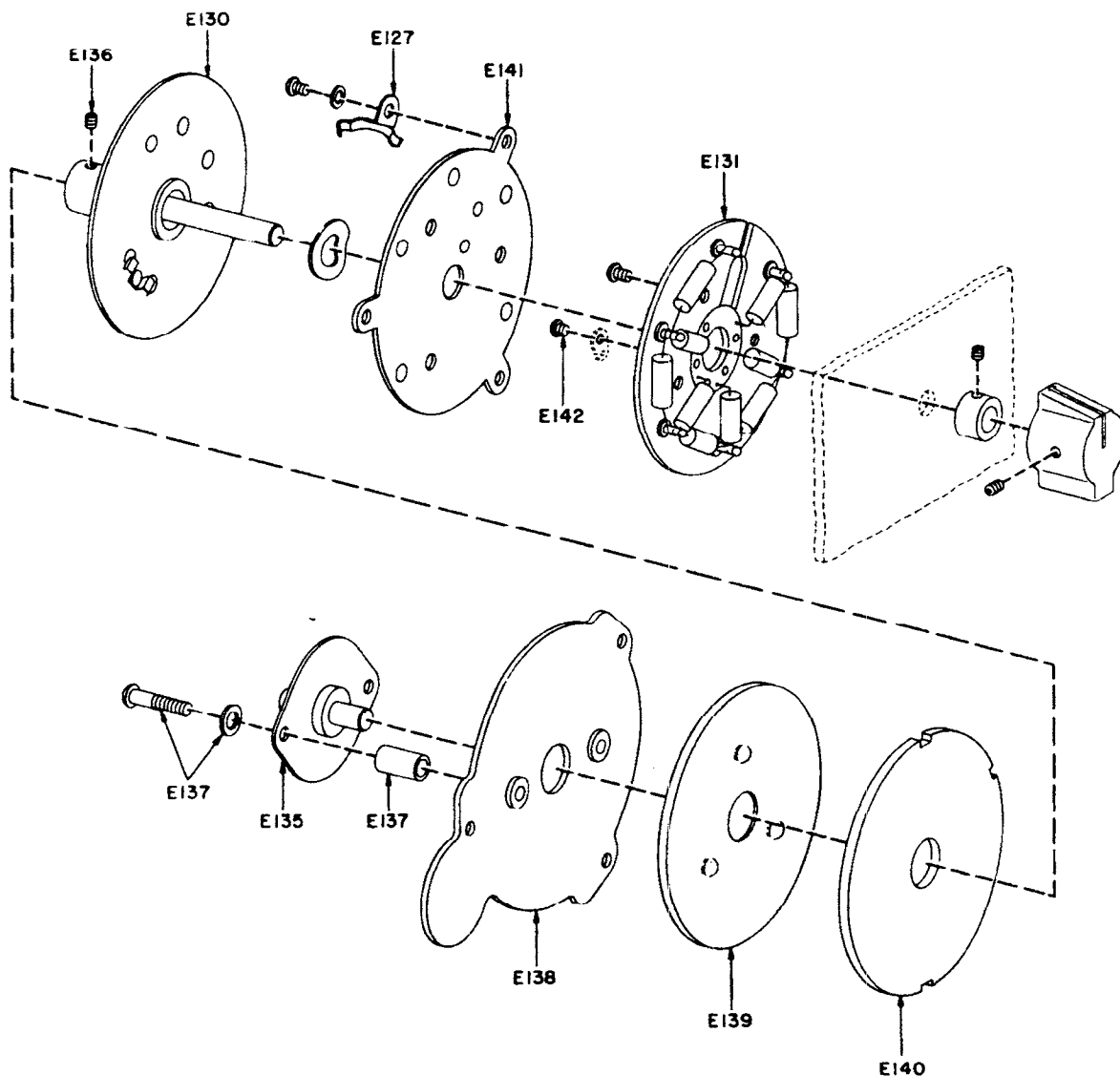

Figure 7-4. Attenuator, Exploded View

- (8) Lift off cover assembly (E138).
- (9) Lift out grounding cover (E139).
- (10) Lift out contact ring (E140).

**Note**

It is not necessary to unsolder connecting lead unless replacing contact ring.

(11) Loosen front panel attenuator knob set screws. Use the #6 Allen wrench supplied in front cover.

(12) Pull off knob.

(13) Loosen attenuator collar set screw. Use #6 Allen wrench.

(14) Pull off collar.

(15) Reposition signal generator chassis face down.

(16) Lift out wiper plate assembly (E130). This assembly contains 10-db pad resistors.

(17) Remove spring washer. The washer maintains proper contact between wiper plate assembly and insulator assembly.

(18) Remove three grounding contacts (E127) by unscrewing holding screw on each contact.

(19) Remove two screws holding insulator assembly.

(20) Lift out insulator assembly (E141).

(21) Remove three screws holding contact plate (E131) to front panel casting.

(22) Remove five screws holding five grounding lugs (E142).

(23) Unsolder lead from signal generator interior to contact plate (E131). Remove plate. This plate contains the 20-db pad resistors.



b. Reassembly Instructions.

- (1) Reassemble the attenuator in reverse order of disassembly. Observe the following additional instructions.
- (2) Rethread lead from contact plate through hole and resolder to proper connection.
- (3) Carefully align ground lug screws noting that each screw holds its own ground lug and that no adjacent screw heads touch each other.
- (4) When replacing contact plate holding screws, reseal screws with insulating compound.
- (5) Handle insulator assembly carefully. Do not distort edges that maintain ground contact.
- (6) Align grounding contacts as close to wall of attenuator as possible.
- (7) Replace spring washer on shaft.
- (8) Insert wiper plate assembly with 10-db pad resistors facing up.
- (9) When replacing retaining collar on front panel attenuator shaft, pull on shaft before tightening collar screws. This is necessary to insure proper contact of wiper arms.
- (10) Connect an ohmmeter between double wiper contacts and ground.

- (11) Rotate wiper plate assembly through 360 and check for readings on all 12 positions. Ten steps will read 50 ohms, the other 2 steps will read 55 ohms.
- (12) Align contact ring slot to clear projecting screw.
- (13) Replace grounding cover and attenuator cover.
- (14) Replace detent. Do not tighten set screws.
- (15) Temporarily tighten front panel knob.
- (16) Connect an ohmmeter between the RF OL 1-PU1 jack center contact.

**CAUTION**

Do not use an ohmmeter that places a current greater than 25 milliamperes through the attenuator resistors.

- (17) Rotate attenuator knob until the ohmmeter reads 55 ohms. Only one position will show 55 ohms; the others will read 50 ohms.
- (18) Retaining the 55-ohm position, turn knob in each direction to determine area of contact. Set shaft to center of contact area.
- (19) Tighten set screws on detent collar.
- (20) Loosen knob set screw, being careful not to

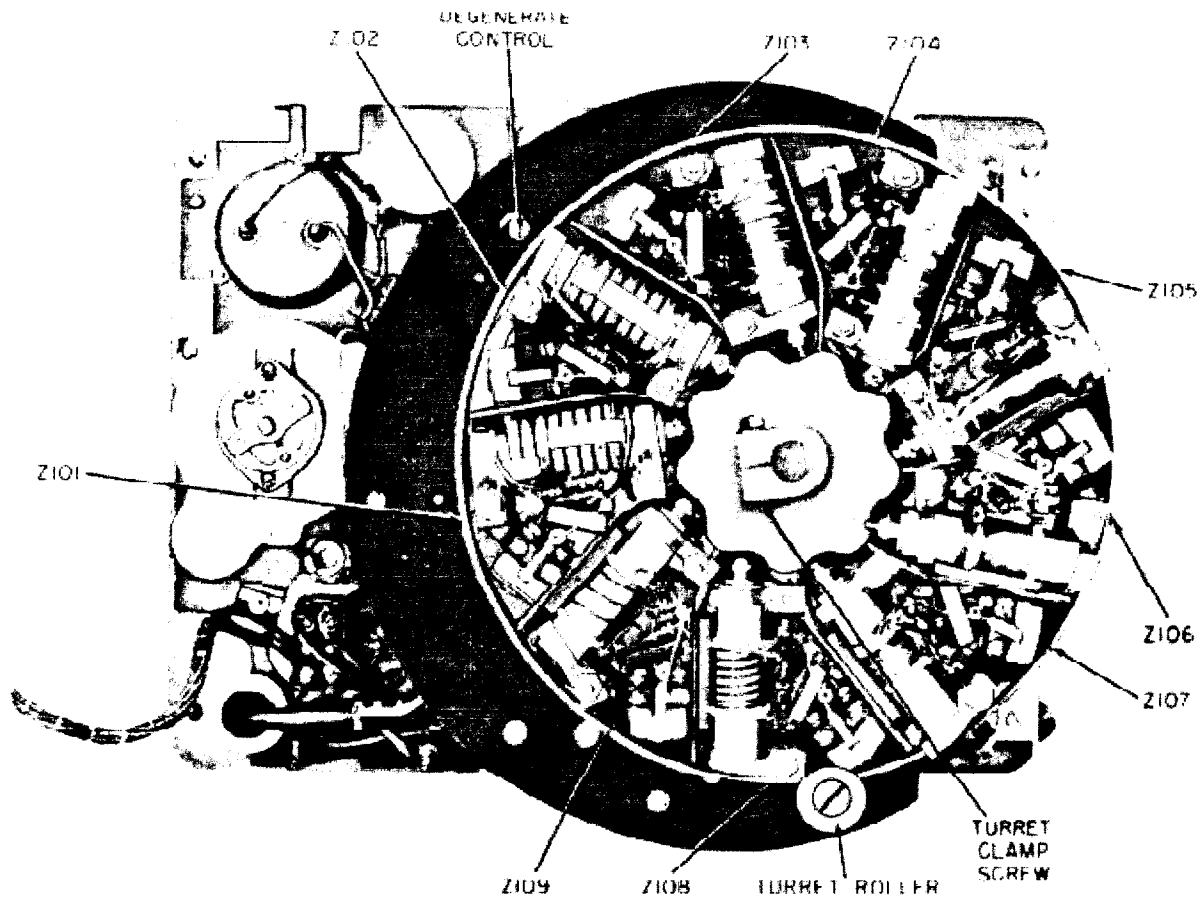

Figure 7-5. Oscillator Coil Turret

turn shaft. Reposition knob at 100,000 microvolt position and tighten set screw.

Final check—Rotate attenuator through all remaining positions. A 50-ohm reading should be obtained on each position.

### 11. REMOVAL OF OSCILLATOR COIL TURRET.

#### a. Procedure.

(1) Remove the signal generator from its case. See paragraph 7.

(2) Remove the RF shield assembly. See paragraph 7.

(3) Position the signal generator chassis face down and allow it to rest on the front panel handles.

(4) Loosen turret clamp screw. (See figure 7-5.)

(5) Remove turret roller and screw. (See figure 7-5.)

(6) Lift up turret assembly.

### WARNING

Turret detent roller will spring out when lifting out turret assembly.

#### b. Reassembly Instructions

(1) Reassemble the turret assembly in reverse order of removal instructions. Observe the following additional instructions.

(2) Brace front panel of band switch knob to prevent movement. A block of wood between knob and surface of bench will suffice.

(3) Replace detent roller with narrow end of taper upward.

(4) Align band switch shaft with flat in turret assembly.

(5) Use a screwdriver to press detent roller into guide on the underside of turret casing.

### 12. REMOVAL OF OSCILLATOR TRANSFORMER ASSEMBLY. (See figures 7-6 and 7-7.)

#### a. Procedure.

(1) Remove the signal generator from its case. See paragraph 7.

(2) Remove RF shield assembly. See paragraph 8.

(3) Position the signal generator chassis face down and allow it to rest on the front panel handles.

(4) Rotate turret assembly so that desired oscillator sector assembly has its trimmer capacitor approximately above feed-thru capacitor C125. See figures 7-6 and 7-7.

(5) Remove the two holding nuts and catch two holding bolts which will drop down.

(6) Lift out oscillator sector assembly.

#### b. Installation Instructions.

Follow removal instructions in reverse order.

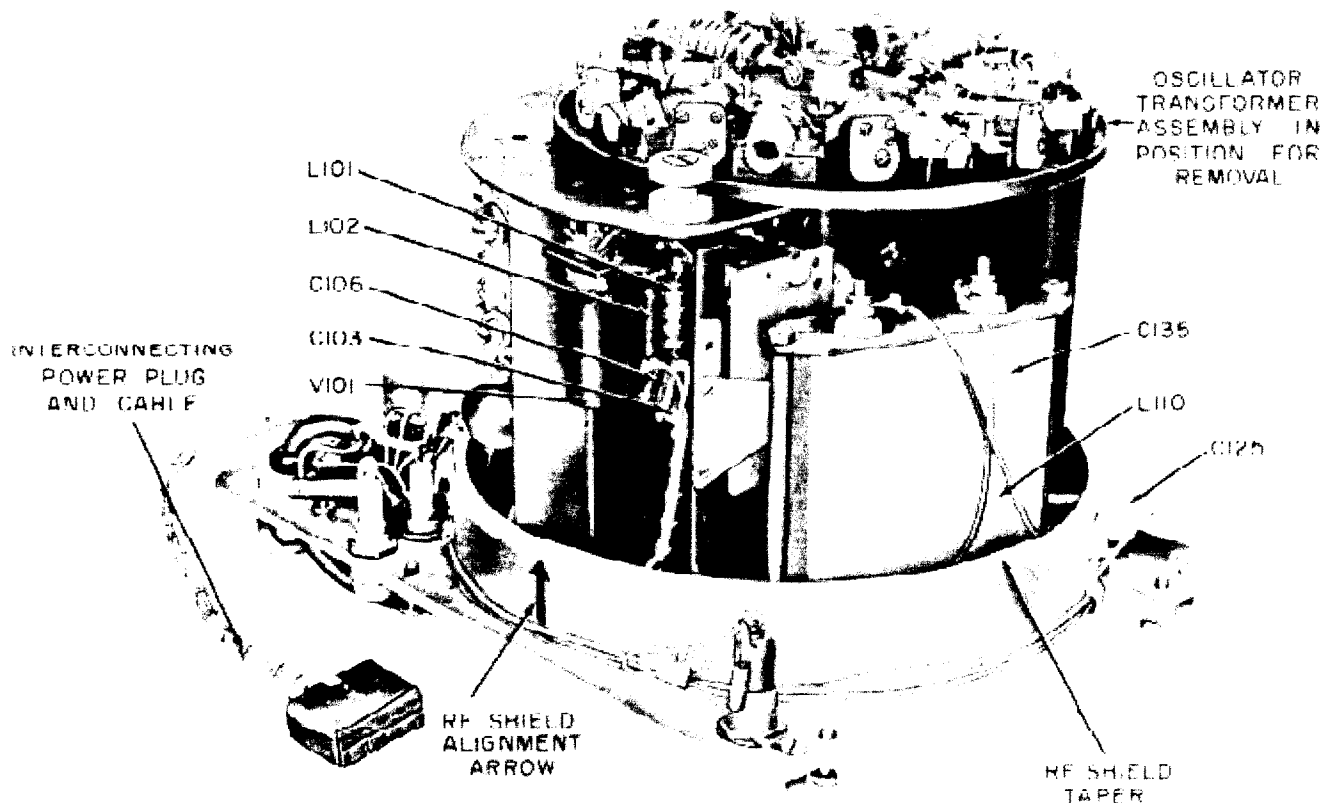

Figure 7-6. Bridge Assembly Components

### 13. REMOVAL OF TUNING CAPACITOR.

(See figure 7-7.)

#### a. Procedure.

- (1) Remove the signal generator from its case. See paragraph 7.
- (2) Remove the RF shield assembly. See paragraph 8.
- (3) Position the signal generator chassis face down and allow it to rest on the front panel handles.
- (4) Remove wing nuts holding C135 (8 ufd 600 V capacitor) leaving leads intact.
- (5) Remove turret assembly. See paragraph 11.
- (6) Remove buffer amplifier tube V102.
- (7) Loosen tuning capacitor flexible coupling.
- (8) Through opening in top, unsolder two connections to tuning capacitor C101.
- (9) From side unsolder the connection from tuning capacitor C102.
- (10) From side unsolder components on tuning capacitor ground terminal.
- (11) Remove two screws on capacitor support.
- (12) Remove four screws holding capacitor mounting plate.
- (13) Remove tuning capacitor.

#### Note

Eight insulating spacers will drop out.

#### b. Reassembly Instruction.

- (1) Reassemble by using the removal instructions in reverse order up to step "8."
- (2) Realign 8 insulating spacers.
- (3) Before replacing connecting wires check with ohmmeter for short from frame of tuning capacitor to ground.
- (4) Do not tighten set screws on flexible coupling.
- (5) Turn tuning capacitor to maximum capacity.
- (6) Turn frequency knob (E107) fully counterclockwise.
- (7) Tighten one set screw in coupling.
- (8) Turn frequency knob clockwise 8 divisions.
- (9) Loosen set screws in coupling.
- (10) Turn frequency knob fully counterclockwise.
- (11) Retighten both set screws in coupling.
- (12) Continue reassembly in reverse order of removal.
- (13) Recalibrate all frequency bands. (See paragraph 15.)

### 14. REPLACING RF OSCILLATOR CIRCUIT COMPONENTS.

a. The RF oscillator frequency determining components listed in Table 2-2 and tuning capacitor C100A should not normally be replaced in the field unless the necessary calibrating instruments are available. These instruments include RF heterodyne frequency meters that cover from 10 kilocycles to 50 megacycles with an accuracy of at least 0.05 percent (e.g. AN/USM-29).

b. Changing the oscillator tube should not normally cause error in calibration. However, when replacing the oscillator tube, the signal generator should be recalibrated as soon as possible.

### 15. READJUSTMENT OF FREQUENCY CALIBRATION. (See figure 7-5.)

a. *WHEN TO CALIBRATE.* The signal generator should be recalibrated whenever oscillator coils or capacitors are replaced and whenever it is suspected that the frequency error is in excess of  $\pm 0.5$  percent. This recalibration is accomplished by adjusting the oscillator coil tuning slugs and trimmers as discussed in paragraph 16 of this section.

b. *LIMITATIONS OF INTERNAL CRYSTAL OSCILLATOR (V106) FOR FREQUENCY RECALIBRATION.* The use of the integral crystal calibrator for interpolative calibration was discussed in Section 4. When used in this manner, the accuracy of the signal generator is increased from the rated  $\pm 0.5$  percent to  $\pm 0.05$  percent at frequencies above 15 megacycles. Since the crystal calibrator operates on the harmonic generation principle, it is limited as a recalibrating device when some circuit defect or replacement introduces a frequency error greater than 0.5 percent. For example: if for some reason, the frequency error at 50 megacycles is 2 percent, the frequency scale will read 50 megacycles when the actual frequency is 51 megacycles. Since zero beats occur at both 50 and 51 megacycles (1 megacycle apart), it will be difficult to determine which point corresponds to 50 megacycles. Similarly, at lower frequencies (down to 1 megacycle), the combination of signal generator and crystal calibrator harmonics may introduce beats at intervals closer than 1 megacycle. Since the accuracy of the signal generator is better than  $\pm 0.5$  percent, there will be no problem in determining the zero beat for interpolative calibration. When recalibrating the instrument because of errors greater than 1 percent, the instruments in the following paragraph should be used to avoid any possible confusion.

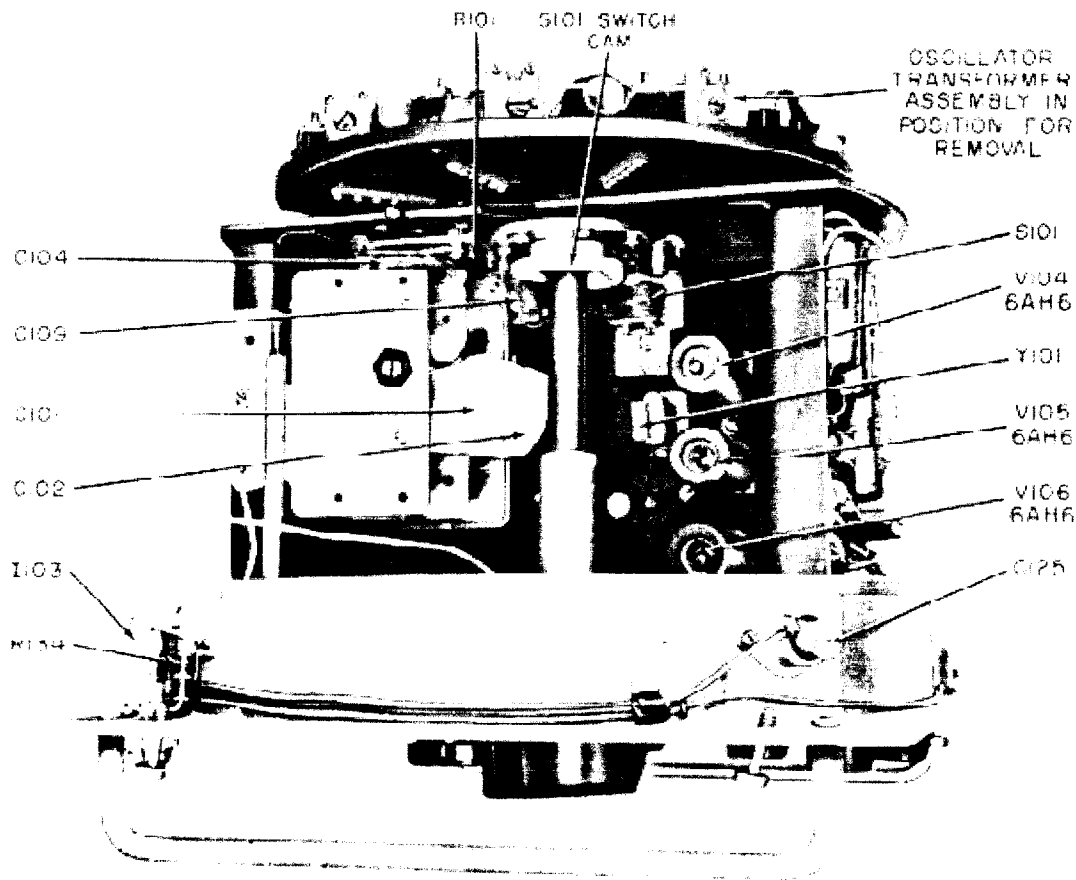

Figure 7-7. Bridge Assembly Components

c. RECOMMENDED TEST EQUIPMENT FOR RECALIBRATING

- (1) AN/USM-29 Frequency Meter.
- (2) Set of high impedance headphones for monitoring zero beat.

**Note**

The tuning slugs and trimmers for each band are available through holes in the RF shield. (See figure 7-3.) The correct slug and trimmer for each band being calibrated are automatically brought in alignment with these holes. DO NOT REMOVE SHIELD FOR CALIBRATION PURPOSES.

**16. RF OSCILLATOR CALIBRATION PROCEDURE.**

(See figures 7-3 and Table 7-1.)

a. Preparation.

- (1) Remove the signal generator from its case. (See paragraph 7. (Do not remove RF shield assembly.)

- (2) When calibrating above 100 kilocycles, connect the signal generator to either the Navy Model AN/USM-29 or AN/URM-82 frequency meter.

- (3) Plug a pair of headphones into the audio output of the frequency meter. Make the necessary adjustments as described in procedure, paragraph b below.

- (4) When calibrating below 100 kilocycles, use Oscilloscope OS-8/U and either the AN/URM-82 or AN/USM-29. Inject a signal from the AN/URM-82 or AN/USM-29 into the horizontal plates of the oscilloscope. Connect the output of Signal Generator AN/URM-25F to the vertical plates of the oscilloscope. Adjust the AN/URM-25F until a circle appears on the oscilloscope screen. (Occasionally, it may be necessary to operate on one of the harmonics of the AN/URM-82 or AN/USM-29. In this case, the AN/URM-25F is adjusted until the proper Lissajous figure appears on the oscilloscope. For example, if the output of the

AN/USM-29 is 20 kilocycles and the signal from the AN/URM-25F is 10 kilocycles, a Lissajous pattern showing a figure eight on its side will be seen on the oscilloscope.)

**Note**

Alignment of frequency bands may be done in any order.

- (1) Position the signal generator with front panel vertical and bottom side of chassis up.
- (2) Select the band to be calibrated.
- (3) Adjust TUNING knob to the low end calibration point. (See Table 7-1.)
- (4) Locate two alignment holes in RF shield assembly. One hole permits trimmer adjustment and the other inductance (slug) adjustment. Refer to figure 7-3.
- (5) Use non-metallic screwdriver and adjust the slug of coil for correct frequency. Obtain zero beat or zero-shaped Lissajous pattern.
- (6) Adjust TUNING knob to high end calibration point. (See Table 7-1.)
- (7) Adjust trimmer for correct frequency. Obtain zero beat or zero-shaped Lissajous pattern.

**Note**

Use insulated screwdriver to prevent shorting B+ to ground. The trimmer is at B+ potential.

- (8) Repeat steps 5 and 7 until no further adjustment is necessary.
- (9) Check mid-point of band for accuracy.

**CAUTION**

After the necessary adjustments have been made on the upper and lower ends of the band being calibrated, the corresponding calibrations should be correct throughout the frequency range. If not, the main tuning capacitor assembly C100A may be defective. One common way that the tuning condenser becomes defective is through "plate bending". Never bend the plates in attempting to make an adjustment in frequency.

**17. REMOVAL OF BRIDGE ASSEMBLY.**

(See figures 7-6, 7-7, 7-8 and 7-9.)

*a.* Procedure.

- (1) Remove the signal generator from its case. See paragraph 7.
- (2) Remove the RF shield assembly. Refer to paragraph 8.
- (3) Unsolder the three leads from terminal board TB106.
- (4) Unsolder ground lead from ground lug adjacent to the attenuator inside front panel.

- (5) Unsolder step attenuator lead from terminal board TB101.
- (6) Unsolder resistor R120 from HIGH RF OUTPUT jack J101.
- (7) Unsolder three tube heater leads from C126.
- (8) Unsolder three tube heater ground leads from ground lug near C126.
- (9) Unsolder red B+ lead from C125.
- (10) Unsolder red-white lead from L110.
- (11) Loosen couplings on the following shafts:
  - Function switch
  - Modulation level control
  - Microvolts control
  - Tuning
- (12) Loosen clamp screw on turret.
- (13) Loosen set screws on turret shaft cams.
- (14) Remove four 10-32 screws at the base of bridge assembly.
- (15) Lift bridge assembly away from the front panel.

**CAUTION**

Lift cam along with the bridge assembly. Failure to do so will result in the damage of switch S101.

*b.* Reassembly Instructions.

- (1) Reassemble the bridge assembly in reverse order of disassembly.
- (2) Check cam switch for operation. See that cam operates switch S101 on the three lowest frequency bands (10 kilocycles to 220 kilocycles).
- (3) When tightening the coupling on the frequency control shaft, follow the procedure in section 7-13, paragraphs *b* (4) through *b* (11).

**18. RF METERING CALIBRATION.** (See figure 7-8.)

*a.* Procedure.

- (1) Remove the signal generator from its case. See paragraph 7.
- (2) Remove the RF shield assembly. See paragraph 8.
- (3) Set the signal generator to 100 kilocycles.
- (4) Set the FUNCTION SWITCH to CW position.
- (5) Connect a high impedance RF volmeter to the HIGH RF OUTPUT jack J101. Be sure to depress center contact of the jack to release short across jack. The W101 cable may be used to connect the RF meter.
- (6) Adjust set RF OUTPUT control (E101) until 2 volts of RF is measured at jack J101.
- (7) Adjust (R160) RF METER CAL control until the front panel meter (M101) indicates 10 on the microvolts scale.

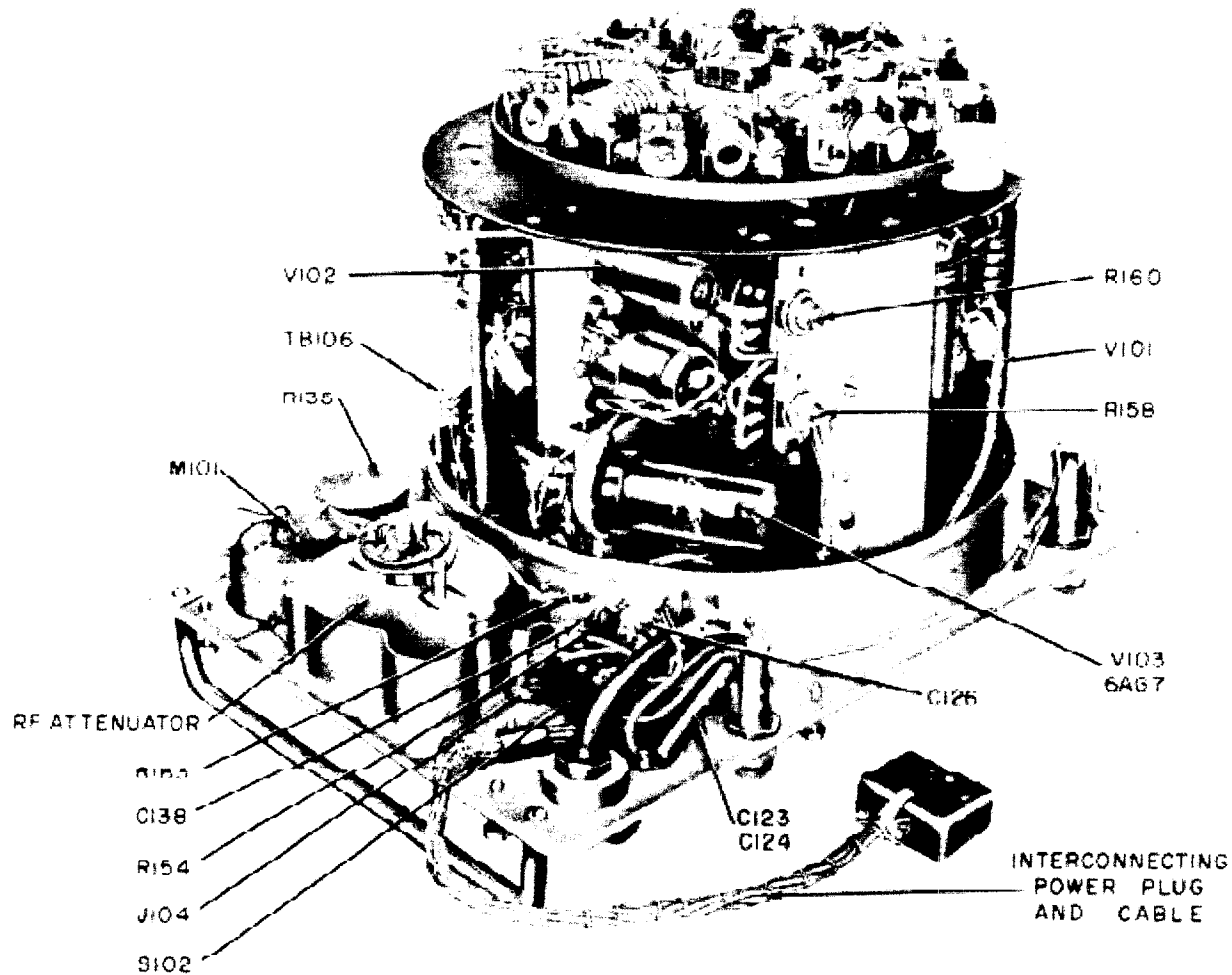

Figure 7-8. Bridge Assembly Components

**19. PERCENT MODULATION METER CALIBRATION.** (See figure 7-8.)

*a.* Procedure.

- (1) Remove the signal generator from its case. See paragraph 7.
- (2) Remove the RF shield assembly. See paragraph 8.
- (3) Turn FUNCTION SWITCH to CW position.
- (4) Adjust carrier output to 100,000 microvolts.
- (5) Turn FUNCTION SWITCH to INT MOD 400 cycles position.
- (6) Turn % MOD control fully counterclockwise.
- (7) Connect the RF OUTPUT jack (J102) to the vertical input terminals of an oscilloscope.
- (8) Place a graduated celluloid screen over the face of the oscilloscope.
- (9) Adjust vertical gain of oscilloscope for 50 percent coverage on screen. Refer to figure 7-11, unmodulated carrier.

(10) Turn the % MOD control (E104) until front panel meter reads 50 percent modulation.

(11) Turn the MOD METER ADJ control (R158) until oscilloscope pattern indicates 50 percent modulation. See figure 7-11, 50 PERCENT MODULATION.

(12) Turn the % MOD control (E104) until front panel meter reads 30 percent modulation.

(13) Observe oscilloscope pattern. It should appear as drawn in figure 7-11, 30 PERCENT MODULATION.

(14) If necessary readjust (R158) MOD METER ADJ control until 30 and 50 percent readings are both as accurate as possible, favoring the 30 percent adjustment since this value is used most often.

**20. RF STEP ATTENUATOR TESTS.**

*a.* GENERAL. By the proper use of the 10-db steps of the attenuator together with the front panel meter (M101), the accuracy of both the attenuator and meter may be checked.

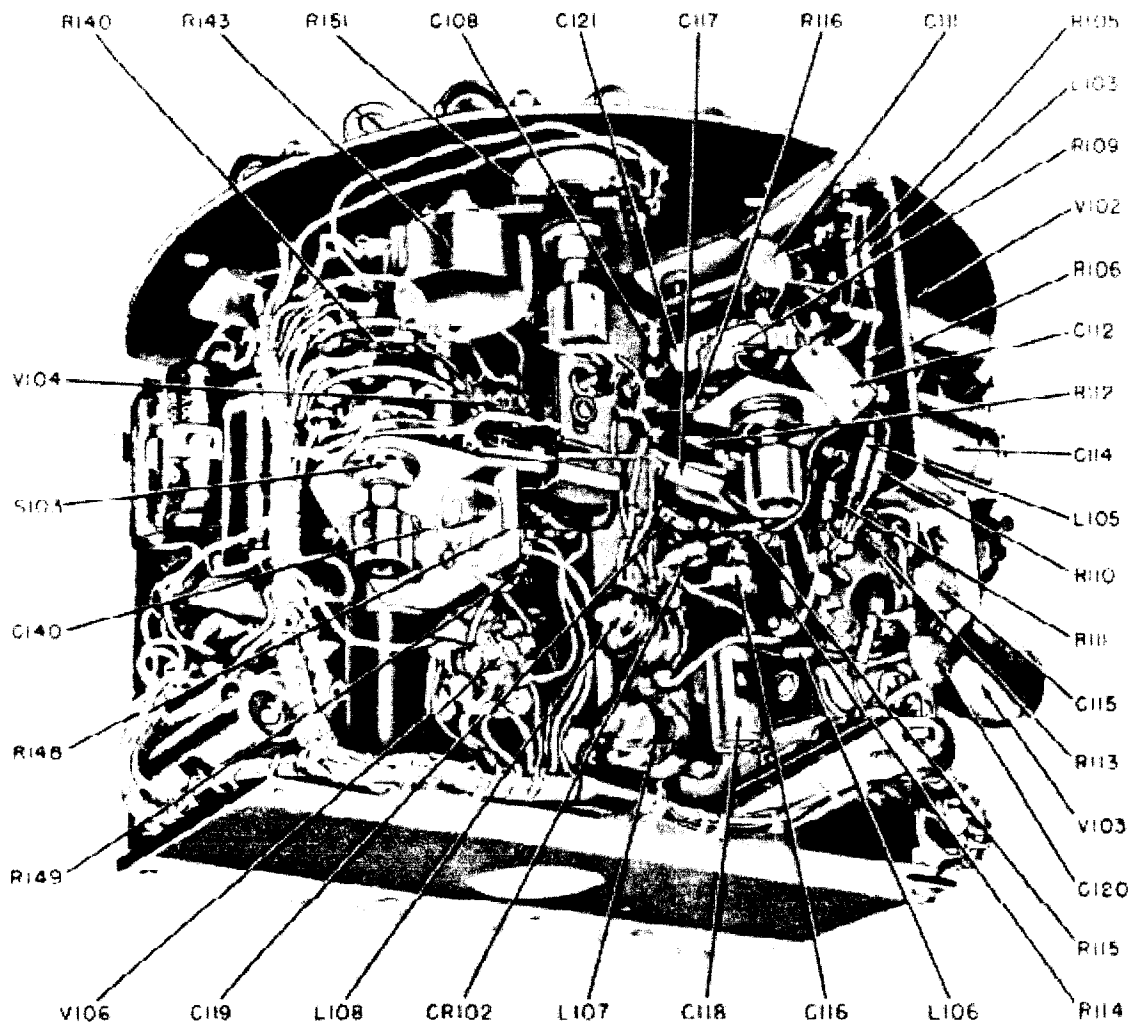

Figure 7-9. Bridge Assembly Components

**b. PROCEDURE.**

- (1) Connect the signal generator, properly terminated, to a calibrated receiver.
- (2) Set the ATTENUATOR knob to the 100,000 microvolt position.
- (3) Adjust the MICROVOLTS control to obtain a reading of 3 on the top microvolts scale of the meter. (Actual output voltage is now 30,000 microvolts.)
- (4) Record the receiver output.
- (5) Turn the ATTENUATOR to the 30,000 microvolt position.
- (6) Readjust the MICROVOLTS control for a reading of 3 on the lower microvolts scale of the meter.
- (7) Record the receiver output.
- (8) The ratio of the output voltages recorded in steps 4 and 7 should be 1, and not more than 1.1 for 10 percent tolerance.

(9) Repeat similar procedure on each pair of adjacent attenuator steps. For example: between 30,000 microvolts and 10,000 microvolts positions; between 10,000 microvolts and 3,000 microvolts positions.

(10) If the ratio found in step 8 is greater than 1, the defective section of the attenuator may be found as follows:

*a.* If there is a constant error between the steps, this indicates that the meter (M101) or germanium diode (CR101) is defective.

*b.* If the ratios between the adjacent steps are the inverse of each other and this is true of all adjacent pairs, the 10-db pad is defective.

*c.* If the error is found only at one 10-db step, the 20 db section of the ladder network associated with that step is defective.

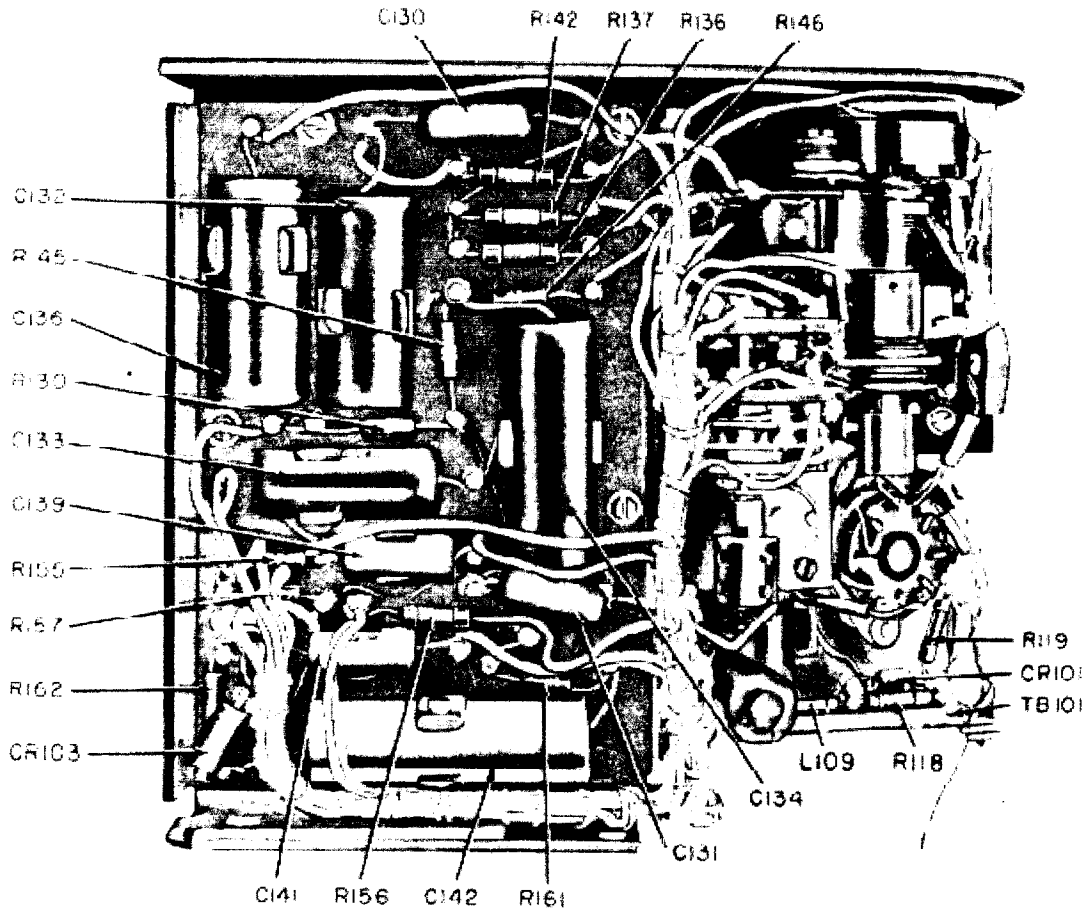

Figure 7-10. Bridge Assembly Components

100%

$A_p = 20$  DIVISIONS  
 $A_c = 2$  DIVISIONS

50%

$A_p = 10$  DIVISIONS  
 $A_c = 5$  DIVISIONS  
 $A_p = 2 \times A_c$

$A_p = 10$  DIVISIONS  
 $A_c = 7$  DIVISIONS  
 $A_p = \frac{10}{7} \times A_c$

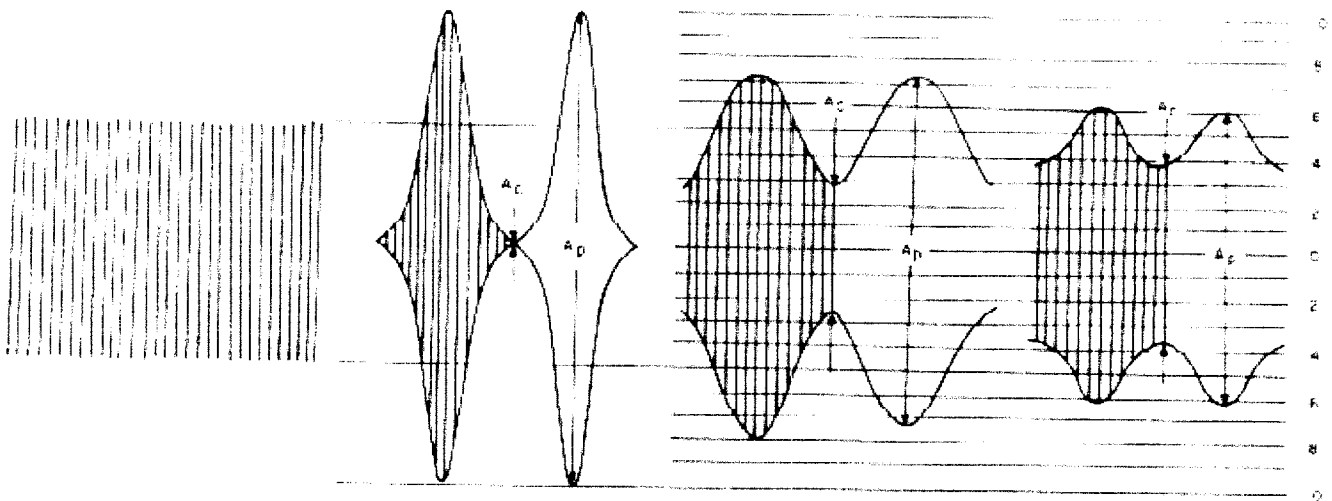

UNMODULATED CARRIER  
(10 DIVISIONS)

$$\% \text{ MODULATION} = \frac{A_p - A_c}{A_p + A_c} \times 100$$

Figure 7-11. Percentage Modulation Chart



## 21. CRYSTAL OSCILLATOR CALIBRATION.

(See figure 7-9.)

### a. Procedure.

- (1) Remove the signal generator from its case. Refer to paragraph 7.
- (2) Remove the RF shield assembly. See paragraph 8.
- (3) Tune a receiver, such as a Navy Model RBC series to the 5 megacycle signal of Station WWV.
- (4) Rotate the SET RF OUTPUT control on the signal generator fully counterclockwise.
- (5) Turn the FUNCTION SWITCH to CAL position.
- (6) Connect the HIGH RF OUTPUT jack (H01) to the antenna input of the receiver.
- (7) Adjust crystal oscillator trimmer, (C140) for zero beat against 5 megacycle transmission of WWV. (This will be the fifth harmonic of the 1 megacycle crystal.) Zero beat will be heard on receiver loudspeaker.

## 22. DIAL SCALE LAMP REPLACEMENT.

(See figure 7-2.)

### a. Procedure.

- (1) Loosen Allen head set screw in band switch knob.
- (2) Pull off knob.
- (3) Loosen Allen head set screw in tuning knob.
- (4) Remove 5 screws holding dial plate cover.
- (5) Remove dial cover and tuning knob.
- (6) Dial scale lamps (1101 and 1102) are then exposed for replacement.
- (7) Replace lamps with Navy type 1S52.

### b. Reassembly.

- (1) Reassemble in reverse order of removal instructions.
- (2) Rotate tuning control shaft fully counterclockwise.
- (3) When TUNING knob is replaced on shaft, tighten knob so that the index mark coincides with graduation mark 8 on the TUNING knob scale.

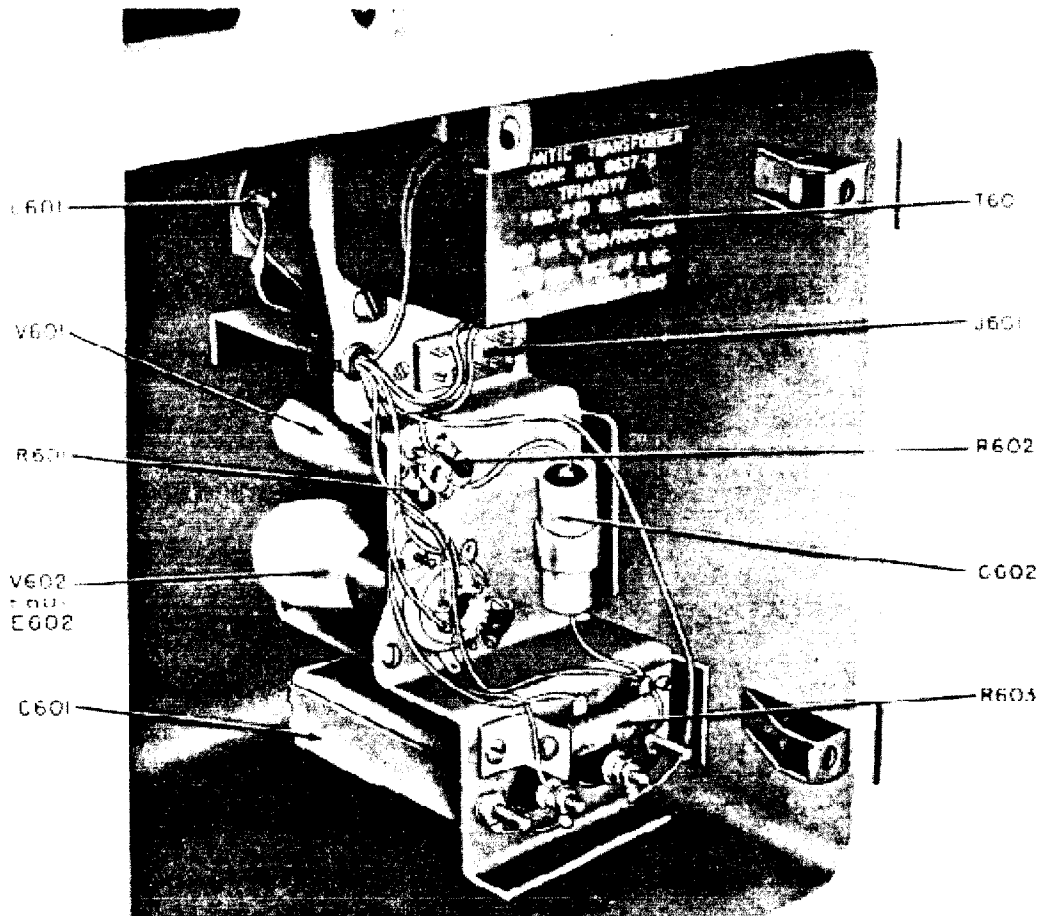

Figure 7-12. Power Supply PP-1322/URM-25F

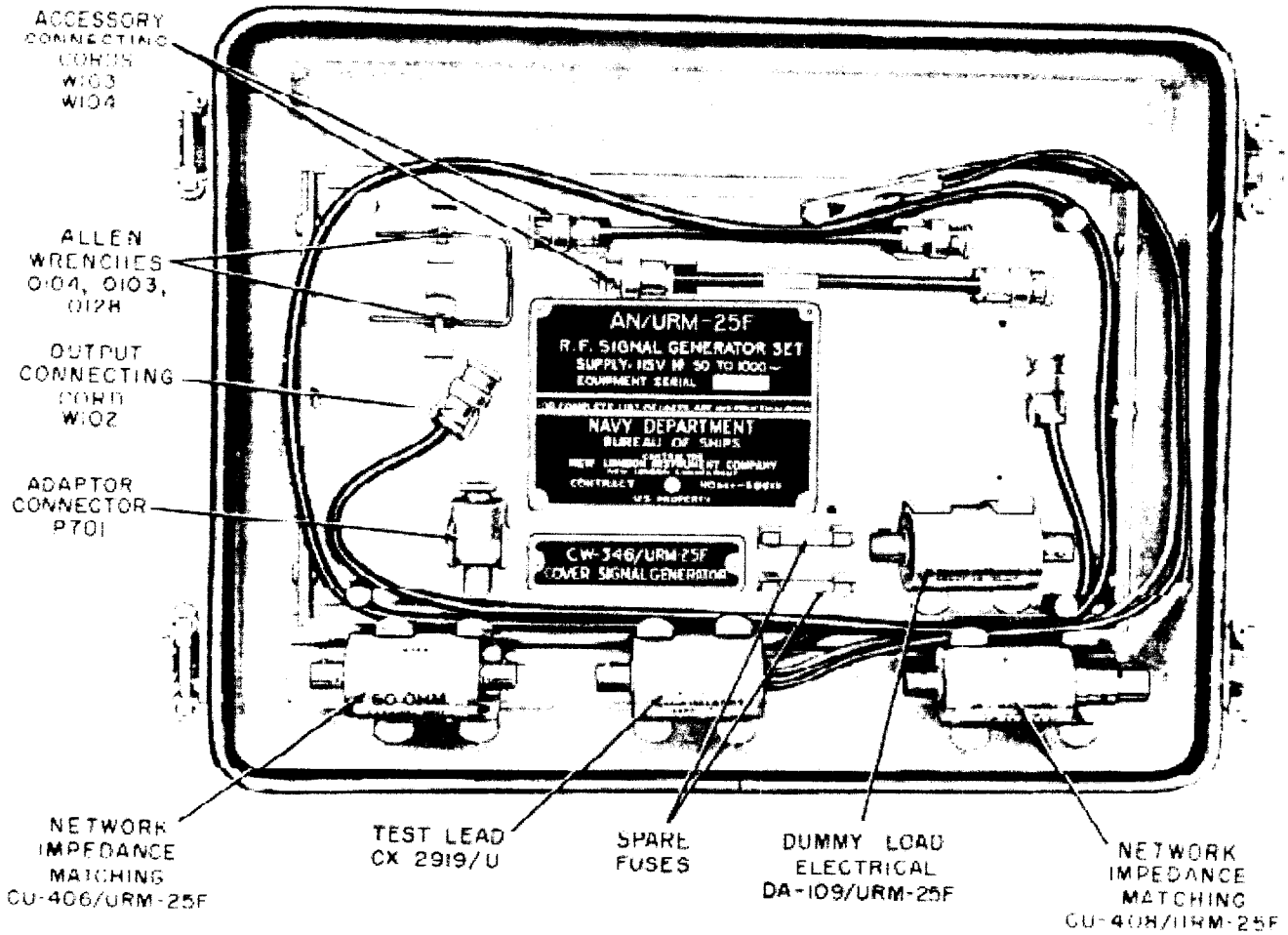

Figure 7-13. Cover, Signal Generator CW-346/URM-25F, Accessory Units Mounted

TABLE 7-1. FREQUENCY CALIBRATION DATA

BAND SWITCH SETTING	LOW END—ADJUST SLUG		HIGH END—ADJUST TRIMMER	
	FREQ	COIL	FREQ	CAPACITOR
10-26 KC	11 KC	T102	25 KC	C146
26-75 KC	30 KC	T103	70 KC	C149
75-220 KC	90 KC	T104	200 KC	C152
220-600 KC	250 KC	T105	550 KC	C155
0.6-1.5 MC	.75 MC	T106	1.3 MC	C158
1.5-3.8 MC	1.75 MC	T107	3.5 MC	C161
3.8-10 MC	4.5 MC	T108	9.0 MC	C164
10-25 MC	12.0 MC	T109	22.5 MC	C167
25-50 MC	25.0 MC	T110	45.0 MC	C170

TABLE 7-2. TROUBLE SYMPTOM CHART

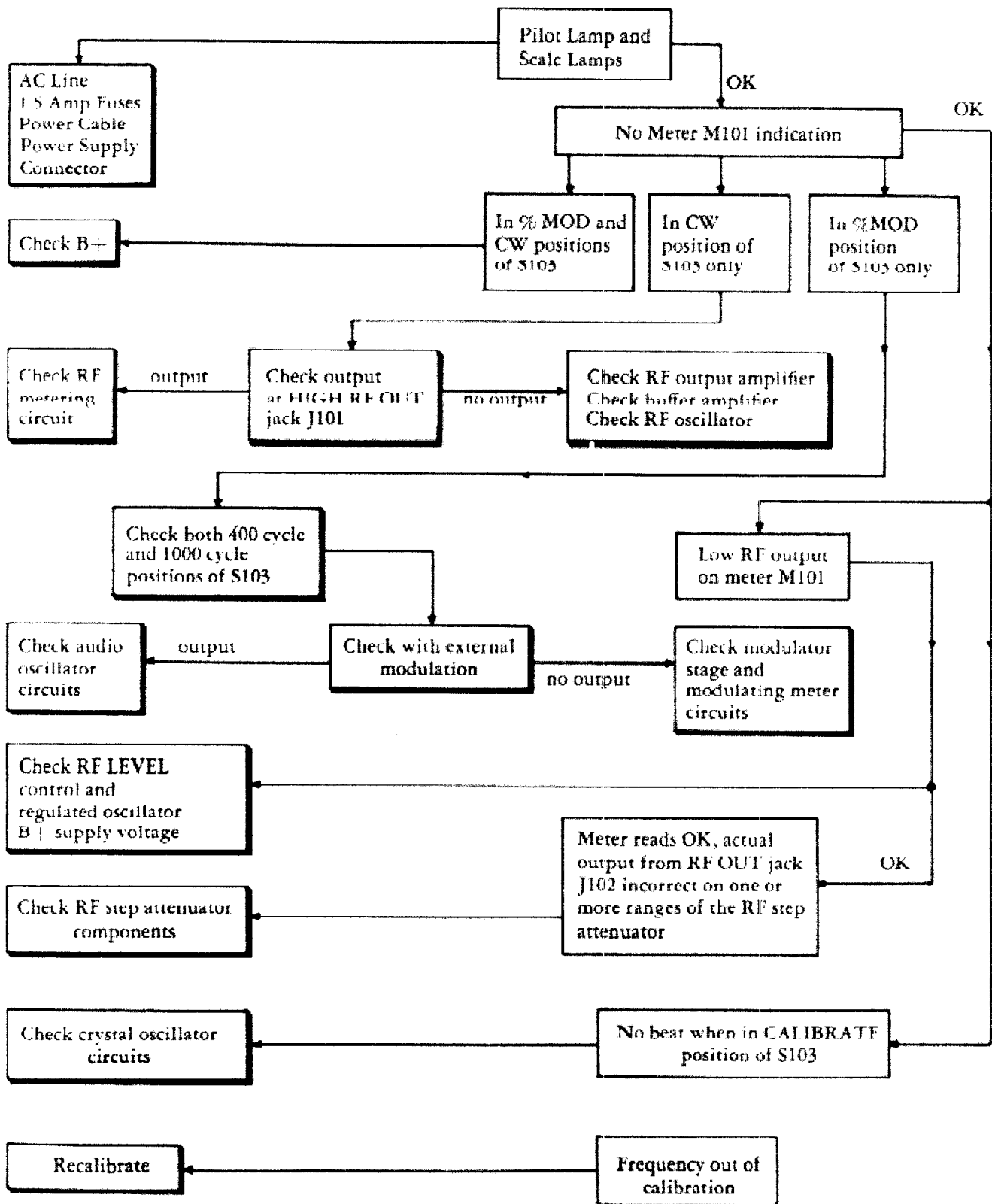

TABLE 7-3. TROUBLE LOCALIZATION CHART

**Note**

Turn the SET RF OUTPUT (E101) and % MOD (E104) controls fully counterclockwise. Turn the MICROVOLTS control (E105) fully clockwise.

CIRCUIT LOCALIZATION	LOCALIZATION METHOD
1. POWER SUPPLY	<p><i>a.</i> Turn power switch (S102) on. If power ON lamp (I103) and dial scale lamps (I102 and I101) light, the 115V AC fuses, and at least part of the power supply is functioning. If none of the lamps light, see table 7-4, paragraph 1.</p>
2. RF OSCILLATOR, BUFFER AMPLIFIER, MODULATED RF AMPLIFIER, AND RF METERING CIRCUITS	<p><i>a.</i> Set the FUNCTION SWITCH (103) in the CW position.</p> <p><i>b.</i> Rotate the SET RF OUTPUT control (E101) slowly from the counterclockwise to clockwise position; the meter (M101) should move toward full scale deflection. If it does, the RF oscillator, buffer amplifier, modulated RF amplifier and RF metering circuits are functioning properly.</p> <p><i>c.</i> Set the BAND SWITCH (E106) to all ranges and check for operation as described previously in paragraph <i>b.</i> If one or more bands are inoperative, probably the trouble is in the RF oscillator circuit associated with the defective range. See table 7-4, paragraph 3(<i>b</i>).</p> <p><i>d.</i> If test described in paragraph <i>b.</i> did not produce meter deflection, turn the FUNCTION SWITCH (E103) to INT MOD 400 cycle position. Rotate the % MOD control (E104) clockwise. The meter (M101) should move towards full scale deflection. If it does, there is trouble in either the RF oscillator, buffer amplifier, modulated RF amplifier or RF metering circuits. The deflection of the meter movement in this test indicates that the 400 cycle modulation circuits are functioning properly.</p> <p><i>e.</i> If the meter reads in paragraph <i>d.</i> but not in paragraph <i>a.</i> or <i>b.</i>, connect an oscilloscope to the HIGH RF OUT jack (J101). Adjust the signal generator to a carrier frequency between 10 and 500 kilocycles. Turn the SET RF OUTPUT control (E101) clockwise. If a pattern appears on the oscilloscope, the RF metering circuit is defective. See table 7-4, paragraph 4. If a pattern can not be obtained, the RF oscillator, buffer amplifier or modulated RF amplifier is inoperative. See table 7-4, paragraph 2 and 3.</p>
3. AUDIO OSCILLATOR, MODULATION AND MODULATION METERING CIRCUITS	<p><i>a.</i> If the meter (M101) responds to test in paragraph 2 <i>b.</i> but not in paragraph 2 <i>d.</i>, trouble is indicated in the audio oscillator, modulator or modulation metering circuit.</p> <p><i>b.</i> Plug a set of high impedance headphones into the AUDIO OUT jack (J104). Turn the FUNCTION SWITCH (E103) to either 400 or 1000 cycle INT MOD position. If the audio oscillator is heard as the % MOD control (E104) is rotated, the audio oscillator is functioning properly and the modulator or the modulation metering circuit is defective. See table 7-4, paragraphs 6 and 7. If no audio is heard, the audio oscillator is defective. See table 7-4, paragraph 5.</p> <p><i>c.</i> Turn the FUNCTION SWITCH (E103) to the EXT MOD position. Apply a 1,000 CPS external audio signal to the EXT MOD IN jack (J104). Rotate the % MOD control (E104) clockwise. The meter (M101) should indicate modulation. If it does, the audio oscillator is not operating. If the meter does not deflect, the modulator stage or modulation metering circuits are defective.</p>
4. MODULATION METERING CIRCUIT	<p><i>a.</i> If the test in 3 <i>a.</i> does not produce meter deflection, set the signal generator to 100 kilocycles and connect an oscilloscope to the HIGH RF OUT jack (J101). Turn the FUNCTION SWITCH (E103) to CW and set the meter (M101) to the red arc of the meter scale with the SET RF OUTPUT control (E101). Apply external modulation as described in paragraph 3 <i>c.</i> If a modulation pattern (fig. 7-11) appears on the oscilloscope, the modulation metering circuit is defective. See table 7-4, paragraph 7. If a modulation pattern cannot be obtained, the modulator stage is defective. See table 7-4, paragraph 6.</p>
5. RF STEP ATTENUATOR OR OUTPUT CABLES	<p><i>a.</i> If RF output is available at the HIGH RF OUT jack (J101) and cannot be obtained at the RF OUTPUT jack (J102), the step attenuator (E102) or output cables may be defective. See table 7-4, paragraph 8.</p>
6. POWER SUPPLY	<p><i>a.</i> If the meter does not respond to any of the tests, check the power supply. See table 7-4, paragraph 1.</p>

TABLE 7-3. TROUBLE LOCALIZATION CHART (Cont'd)

CIRCUIT LOCALIZATION	LOCALIZATION METHOD
7. CRYSTAL CALIBRATOR	<p>a. Set the FUNCTION SWITCH (E103) to the CAL position. Rotate the SET RF OUTPUT control (E101) fully counterclockwise. The meter pointer should move approximately 1/16 of an inch. If it does not the crystal oscillator is defective. See table 7-4, paragraph 9.</p> <p>b. If the crystal oscillator test moves the meter 1/16 of an inch, tune the signal generator to an RF frequency above 1 megacycle. Adjust the SET RF OUTPUT control (E101) until meter (M101) reads in the red arc of the scale. Connect a set of high impedance headphones to the CAL OUT jack (J104). Beat notes should be heard at the 1 megacycle intervals. If beat notes cannot be obtained the calibrating amplifier is defective. See table 7-4, paragraph 9.</p>

TABLE 7-4. SPECIFIC TROUBLE TEST CHART

**Note**

Turn the SET RF OUTPUT (E101) and % MOD (104) controls fully counterclockwise. Turn the MICROVOLTS control (E105) fully clockwise.

LOCATION AND TYPE OF TROUBLE	TEST INSTRUCTIONS
1. POWER SUPPLY PP-1322/URM-25F	
a. COMPLETE INOPERATIVE	<p>(1) Check fuses (F101) and (F102).</p> <p>(2) Check POWER switch (S102).</p> <p>(3) Check interconnecting power cable between power supply and signal generator chassis with an ohmmeter.</p>
b. NO B+; HEATER VOLTAGE OK	<p>(1) Check rectifier tube (V601). If surge limiting resistors (R601) and (R602) are burnt, suspect heater-cathode short in (V601) or shorted input filter capacitor (C601).</p> <p>(2) Check for B+ short to ground with power off.</p> <p>(3) Measure high voltage winding of power transformer (T601).</p>
c. NO +75 VOLT POWER; +150 VOLT POWER OK	<p>(1) Check voltage regulator tube (V602). Check current limiting resistors (R603) and (R604).</p>
d. OVERHEATING	<p>(1) Check for shorted turns on power transformer (T601).</p> <p>(2) Check for partial breakdown of the input filter capacitor (C601), filter choke (L601) and output filter capacitor (C135).</p>
<b>Note</b>	
An ohmmeter test will not always identify this trouble.	
e. LOSS OF REGULATION	<p>(1) Vary input line voltage between 103 and 126 volts. The +75 volts regulated supply should not change more than 3 volts.</p> <p>(2) Replace the regulator tube (V602) if variation exceeds 3 volts.</p>
2. BUFFER AMPLIFIER AND MODULATED RF AMPLIFIER	
a. NO OUTPUT	<p>(1) Check voltages on buffer amplifier (V102) and modulated RF amplifier (V103). See table 7-5 (Voltage Measurements).</p> <p>(2) Test V102 and V103 in tube checker.</p> <p>(3) Check V102 and V103 resistances to ground with ohmmeter. Use table 7-6.</p>
b. LOW OUTPUT AT FREQUENCIES BELOW 100 KILOCYCLES	<p>(1) Check operation of the modulator audio circuit switch (S101). Cam operation should open the switch on ranges 10-26, 26-75, and 75-220 kilocycles. See figure 7-7.</p>

TABLE 7-4. SPECIFIC TROUBLE TEST CHART (Cont'd)

LOCATION AND TYPE OF TROUBLE	TEST INSTRUCTIONS
3. RF OSCILLATOR a. INOPERATIVE ON ALL BANDS	(1) Check voltages on RF oscillator tube (V101). See table 7-5.
	<b>Note</b>
	Operation of SET RF OUTPUT control (E101) will vary plate voltage. Cathode voltage will be obtained only on bands covering 10 to 1500 kilocycles.
	(2) Make resistance measurements on V101 socket. Refer to table 7-6. (3) Test V101.
b. INOPERATIVE ON 1 OR MORE BANDS	(1) Check continuity and resistance of components of transformer assembly concerned. (2) Check operation of contacts between turret plate and oscillator assembly contact plate. (3) Replace RF oscillator tube (V101). May be inoperative at certain frequencies.
c. ERRATIC OPERATION	(1) Check contacts between turret and oscillator contact plate. (2) Check tube (V101) and substitute a new tube if necessary. (3) Check tuning capacitor (C101) and (C102) for dirty contacts, bent plates etc. (4) Check oscillator transformer assembly of band concerned for poor connections.
4. RF-METERING CIRCUIT	(1) Check diode CR101. (2) Check continuity of circuit.
5. AUDIO OSCILLATOR a. INOPERATIVE ON BOTH 400 CYCLE AND 1000 CYCLE POSITIONS	<b>Note</b>
	If both audio oscillator ranges are inoperative the probability is that a tube (either V104 or V105) is defective on some component common to both frequencies.
	(1) Check tubes (V104) and (V105). (2) Check setting of the DEGEN control. Vibration may have changed its setting. Clockwise rotation of this control may start audio oscillator.
	<b>Note</b>
	The position of the DEGEN control (R143) is a critical adjustment.
b. REGENERATION CONTROL ADJUSTMENT	(1) Turn % MOD control (E104) fully clockwise. (2) Turn DEGEN control (R143), (see figure 7-10), until audio oscillations start. Do not advance beyond this point as distortion of the audio signal will result.
c. INOPERATIVE ON EITHER 400 OR 1000 CYCLE POSITION	(1) Check bridge circuit resistances R136, R137, R140, and R141.
	<b>Note</b>
	The bridge resistors are of 1 percent tolerance and should be checked on a resistance bridge. An ohmmeter measure is not suitable, as a change of 5 percent in value can cause defective operation.
6. MODULATOR STAGE NO MODULATION OF RF CARRIER, AUDIO OSCILLATOR OK	(1) Check voltages at modulator tube socket (V106). Refer to table 7-5. (2) Test tube (V106). (3) Check setting of MOD METER ADJ (R158). See section 7, paragraph 19. (4) Test RF modulated amplifier cathode capacitor (C114). When C114 is open virtually no modulation of the carrier will take place.

TABLE 7-4. SPECIFIC TROUBLE TEST CHART (Cont'd)

LOCATION AND TYPE OF TROUBLE	TEST INSTRUCTIONS
7. MODULATION METERING CIRCUIT	(1) Check meter rectifier (CR103). (2) Check components of metering circuit. (3) If rectifier (CR103) is defective, check surge resistor (R161). If this resistor opens or increases in value switching transients may have caused CR103 to fail.
8. STEP ATTENUATOR a. NO OUTPUT ON ALL STEPS  <b>CAUTION</b> DO NOT USE AN OHMMETER THAT PASSES CURRENTS GREATER THAN 25 MILLIAMPERES THROUGH RESISTORS UNDER TEST.	(1) Check RF output from HIGH RF OUT jack (J101). If output is available attenuator matching resistors (R118) and (R119) may be defective. (2) Check DC resistance from RF OUT jack (J102) to ground. Readings should be 50 ohms on all positions of the attenuator except 100,000 microvolt position which reads 55 ohms. (3) If no or high resistance is measured in step 2, check connection between J102 and contact plate of attenuator. See figure 7-4 for attenuator exploded view. (4) Resistance checks that differ from 50 or 55 ohms indicate that attenuator contacts may be faulty or attenuator resistances are defective. (5) Detailed check of RF attenuator is given in paragraph 20.
b. OUTPUT ON SOME BUT NOT ALL STEPS	(1) One of the step series resistors may be open circuited. This can be checked by measuring resistance as described in 8 a. above. The defective resistance will be between the two contact positions which measure 55 ohms instead of 50 ohms. (2) A resistance reading of other than 50 ohms on every other step indicates a defective resistor in the 10-db pad, or a poor contact between the wiper plate and contact ring.
9. CRYSTAL CALIBRATOR a. CRYSTAL OSCILLATOR NOT OPERATING	(1) Measure RF voltage at plate of crystal oscillator tube (V106). If should be between 12 to 15 volts. (2) If measurement obtained in step 1 is correct, test the coupling capacitor (C119). (3) Check the DC voltage across the mixer diode (CR102). Measurement should show +10 to +12 volts. If it doesn't, the diode is probably defective. (4) If in step 1, no RF voltage is obtained, check voltage at crystal oscillator socket (V106). (5) Test tube (V106). (6) Test crystal (Y101).
b. CRYSTAL OSCILLATOR OPERATING; BUT NO BEAT NOTE	(1) Check calibration amplifier. Touch tip of screwdriver to grid on V104; hum should be heard in headphones. (2) Test voltages at calibration amplifier sockets (V104) and (V105). (3) Test tubes (V104) and (V105). (4) Check DC voltage across mixer diode (CR102). (5) Make continuity check of circuit.
10. HUM MODULATION	(1) Listen for power line hum (impressed on carrier frequency) or check output on oscilloscope. (2) Check for unshielded leads between the signal generator and receiver. All leads between these units should be shielded. (3) Check for mechanical vibrations of the power transformer (T601). (4) Change the RF oscillator tube (V101). (5) Change the modulator tube (V106). (6) Check for open second filter capacitor (C135).
11. ACCESSORY UNITS a. IMPEDANCE MATCHING UNIT CU-406/URM-25F b. ELECTRICAL DUMMY LOAD DA-109/URM-25F c. IMPEDANCE MATCHING NETWORK CU-408/URM-25F d. TEST LEAD CX-2919/U	a. Test accessory units with an ohmmeter or resistance bridge. Refer to figure 7-14 for schematic diagrams.  <b>CAUTION</b> When using an ohmmeter to measure resistances of accessory unit, be sure that ohmmeter current is less than 25 milliamperes.
12. OUTPUT CABLES	Check for leakage resistance with a megger.

TABLE 7-5. TUBE OPERATING VOLTAGES AND CURRENTS

SYMBOL NUMBER	TUBE TYPE	FUNCTION	PLATE VOLTAGE (V)	PLATE CURRENT (MA)	SCREEN VOLTAGE (V)	SCREEN CURRENT (MA)	SUPPRESSOR VOLTAGE (V)	CATHODE VOLTAGE (V)	GRID VOLTAGE (V)	VOLTAGE HEATER AC (V)	PRECAUTIONS
V101	6AH6	RF OSC	+30	0 to 1	+30	0 to 1	+30	+0.5	-1.1	6.3	See notes 1, 2, 3, and 6
V102	6AH6	BUFFER AMP	+150	8.0	+150	2.0	0	+1.5	0	6.3	See note 2
V103	6AG7Y	MODULATED RF AMP	+150	13.0	+150	4.0	0	+4.3	0	6.3	See note 2
V104	6AH6	AUDIO OSCILLATOR	+130	0.2	+130	0.2	+130	+4.0	0	6.3	See note 4
V104	6AH6	CALIBRATION AMP	+50	0.9	+50	0.9	+50	+0.9	0	6.3	See note 5
V105	6AH6	AUDIO OSCILLATOR	+90	1.5	+90	1.5	+90	+1.3	1.0	6.3	See note 4
V105	6AH6	CALIBRATION AMP	+85	1.6	+85	1.6	+85	+1.5	0	6.3	See note 5
V106	6AH6	MODULATOR	+90	6.5	+150	2.5	0	+23	+22	6.3	See note 3
V106	6AH6	CRYSTAL OSCILLATOR	+110	9.0	+150	2.5	0	+2.3	-35	6.3	See note 5
V601	6X4W	FULL WAVE RECTIFIER	180V ACON EACH PLATE	62.5	—	—	—	+175	—	6.3	—
V602	OA3	VOLTAGE REGULATOR	+75	30	—	—	—	0	—	—	—

NOTES: Voltage measurements with respect to ground.

All DC readings obtained with 20,000 ohm/voltmeter.

All AC readings obtained with 1,000 ohm/voltmeter.

(1) RF oscillator frequency set at 1 megacycle.

(2) SET RF OUTPUT control (R135) adjusted to red arc on meter scale.

(3) FUNCTION SWITCH in CW position.

(4) FUNCTION SWITCH in 400 cycle INT MOD position.

(5) FUNCTION SWITCH in CAL position.

(6) Operation of SET RF OUTPUT control (R135) will vary the RF oscillator plate voltage from 0 to 75 volts. (Set as in note 2.)



TABLE 7-6. RESISTANCE MEASUREMENTS

SYMBOL NUMBER	TUBE TYPE	FUNCTION	PLATE PIN	SCREEN PIN	SUPPRESSOR PIN	CATHODE PIN	HEATER PIN	CONTROL GRID PIN	PRECAUTIONS
V101	6AH6	RF OSC	2.2K	CON- NECTED TO PLATE	CON- NECTED TO PLATE	0 to 22K	0	10K to 1 meg.	See notes 1 and 2
V102	6AH6	BUFFER AMP	28K	CON- NECTED TO PLATE	CON- NECTED TO PLATE	150 ohms	0	47K	—
V103	6AG7Y	MODU- LATED RF AMP	28K	28K	0	270 ohms	0	340K or 440K	See note 3
V104	6AH6	AS AN AUDIO OSCIL- LATOR	145K	CON- NECTED TO PLATE	CON- NECTED TO PLATE	20K	0	393K 154K	See note 4 See note 5
V104	6AH6	AS A CALI- BRATE AMPLI- FIER	145K	CON- NECTED TO PLATE	CON- NECTED TO PLATE	1000 ohms	0	700K	See note 6
V105	6AH6	AS AN AUDIO OSCIL- LATOR	70K	CON- NECTED TO PLATE	CON- NECTED TO PLATE	1000 ohms	0	1 meg	See note 4
V105	6AH6	AS A CALI- BRATE AMPLI- FIER	70K	CON- NECTED TO PLATE	CON- NECTED TO PLATE	1000 ohms	0	1 meg	See note 6
V106	6AH6	AS A MODU- LATOR	38K	28K	0	2700 ohms	0	220K	See note 4
V106	6AH6	AS A CRYSTAL OSCIL- LATOR	38K	28K	0	220 ohms	0	220K	See note 6
V601	6X4W	FULL WAVE RECTI- FIER	160 ohms ON EACH PLATE	—	—	29K	0	—	—

TABLE 7-6. RESISTANCE MEASUREMENTS (Cont'd)

SYMBOL NUMBER	TUBE TYPE	FUNCTION	PLATE PIN	SCREEN PIN	SUPPRESSOR PIN	CATHODE PIN	HEATER PIN	CONTROL GRID PIN	PRECAUTIONS
V602	OA3	VOLT-AGE REGU-LATOR	25K	—	—	0	—	—	

## NOTES:

- (1) Resistance measurements on plate pin vary with the setting of R135 SET RF OUTPUT control.  
 (2) Resistance measurements off grid and cathode pins depend on position of the Band Switch and are as follows:

BAND	GRID PIN	CATHODE PIN
1—10 to 26 KC	1 Meg	22K
2—26 to 75 KC	470K	10K
3—75 to 220 KC	330K	6.8K
4—220 to 600 KC	100K	4.7K
5—.6 to 1.5 MC	100K	3.3K
6—1.5 to 3.8 MC	47K	0
7—3.8 to 10 MC	15K	0
8—10 to 25 MC	10K	0
9—25 to 50 MC	47K	0

- (3) Resistance measurement at control grid pin is 440K on Bands 1, 2 and 3 and 340K on Bands 4 to 9.  
 (4) FUNCTION SWITCH in 400 cycle INT MOD position.  
 (5) FUNCTION SWITCH in 1,000 cycle INT MOD position.  
 (6) FUNCTION SWITCH in CALIBRATE position.

TABLE 7-7. RATED TUBE CHARACTERISTICS

TUBE TYPE	HEATER VOLTAGE (V)	HEATER CURRENT (A)	PLATE VOLTAGE (V)	GRID BIAS (V)	SCREEN VOLTAGE (V)	PLATE CURRENT (MA)	SCREEN CURRENT (MA)	AC PLATE RESISTANCE (OHMS)	VOLTAGE AMPLIFICATION FACTOR (MU)	TRANSCONDUCTANCE (MICROMHOS)		EMISSION	
										NOR-MAL	MINI-MUM	IS (MA)	TEST VOLT
6AH6	6.3	.45	300	CATH-ODE RESIS-TOR 150 ohms	150	10	2.5	500K	—	500K	8500		
6AG7Y	6.3	.65	300	-3	150	30	7.0	130K	—	130K	11,000		
6X4W	6.3	.6	300	—	—	75	—	—	—	—	—		
OA3	—	—	75	—	—	5-40	—	—	—	—	—		

RATED GERMANIUM CRYSTAL DIODE CHARACTERISTICS

TYPE	MAXIMUM INVERSE VOLTS (V)	PEAK RECTIFIED CURRENT (MA)	MAXIMUM SURGE CURRENT (MA)	MAXIMUM REVERSE CURRENT (uA)	MAXIMUM AVERAGE CURRENT (MA)
1N145	-30	350	750	.1 (C-10V)	85
1N69	-60	125	400	.05 (C-10V)	40

R176	RESISTOR, fixed: comp. 3.3 meg $\pm 10\%$ ; $\frac{1}{2}W$ ; Spec. MIL-R-11/2.	Xtal, Cal coupling resistor	RC20GF33K	R176	1		
R177	Same as R129.	V107 series grid resistor					
R201	RESISTOR, fixed: wire wound; 3100 ohms $\pm 5\%$ ; 22W; Spec. MIL-R-26.	Power supply series dropping resistor	RW21G312	R201	1		
R301	RESISTOR, fixed: film; 75 ohms $\pm 1\%$ ; $\frac{1}{2}W$ ; Spec. MIL-R-10509B.	p/o 5:1 fixed attenuator CN-223/URM-25D	RN70B75R0F	R301, 303	2		
R302	RESISTOR, fixed: film; 121 ohms $\pm 1\%$ ; $\frac{1}{2}W$ ; Spec. MIL-R-10509B.	p/o 5:1 fixed attenuator CN-223/URM-25D	RN70B1210F	R302	1		
R303	Same as R301.	p/o 5:1 fixed attenuator CN-223/URM-25D					
R401	RESISTOR, fixed: film; 61.9 ohms $\pm 1\%$ ; $\frac{1}{2}W$ ; Spec. MIL-R-10509B.	p/o 10:1 fixed attenuator CN-224/URM-25D	RN70B61R9F	R401, 403	2		
R402	RESISTOR, fixed: film; 249 ohms $\pm 1\%$ ; $\frac{1}{2}W$ ; Spec. MIL-R-10509B.	p/o 10:1 fixed attenuator CN-224/URM-25D	RN70B2490F	R402	1		
R-403	Same as R401.						
R501	RESISTOR, fixed: film; 49.9 ohms $\pm 1\%$ ; $\frac{1}{2}W$ ; Spec. MIL-R-10509B.	p/o impedance adapter MX-1487/URM-25D	RN70B49R9F	R501	1		
R701	RESISTOR, fixed: film; 402 ohms $\pm 1\%$ ; $\frac{1}{2}W$ ; Spec. MIL-R-10509B.	p/o antenna simulator SM-35/URM-25	RN70B4020F	R701	1		
<b>Switches</b>							
S101	SWITCH, rotary; 2 section; 4 positions; 1 pole, 6 stator contacts on 1 section; 4 stator contacts on 1 section; silver alloy contacts; ceramic body; $\frac{1}{2}$ " lg x $1\frac{1}{2}$ " wd x $1\frac{1}{4}$ " high; single hole mig bshg $\frac{3}{8}$ "-32 x $\frac{1}{4}$ " lg; $\frac{1}{4}$ " diam rd shaft $1\frac{1}{2}$ " lg; non-turn device; Spec. MIL-S-3786.	Carrier Range Switch		(18) 107-B-646	107-B-646	S101	1
S102	SWITCH, rotary; 4 section; 5 position; 2 poles per section on 3 sections; 2 stator contacts on 1 section; silver alloy contacts; ceramic body; $1\frac{1}{4}$ " lg x $1\frac{3}{4}$ " wd x $1\frac{1}{4}$ " high; shorting type; solder lug term; signal hole mig; bushing $\frac{3}{8}$ "-32 x $\frac{1}{4}$ " lg; $\frac{1}{4}$ " diam rd metal shaft $\frac{1}{4}$ " lg; non-turn device; Spec. MIL-S-3786.	Mod, Xtal & Meter Selector		(13) 107-B-647	107-B-647	S102	1

TABLE 7-4. COMBINED PARTS AND SPARE PARTS LIST (Continued)

PARTS									
SYMBOL DESIG.	NAME OF PART AND DESCRIPTION	FUNCTION	JAN. AND (NAVY TYPE) NO.	STANDARD NAVY AND (SIGNAL CORP.) STOCK NO.	MFG. & MFG.'S DESIGNATION	CONTRACTOR'S DRAWING PART NO.	ALL SYMBOL DESIG. INVOLVED	QUAN. PER EQUIP.	
<b>Switches (Cont)</b>									
S103	SWITCH, toggle; DPST; 5 amps; 125v dc; phenolic body; 1 1/2" lg x 3/8" wd x 3/8" d; 1/16" lg bat type handle; normally open; solder lug term; single hole mtg bshg 1/2"-32, 1/2" lg; Spec. MIL-S-21195.	Power Off/On Switch	ST22K				S103	1	
<b>Transformer</b>									
T201	TRANSFORMER, power; filament and plate type; 115V, 50/1000 cyc; single ph; two output windings, sec #1 - 6.5V at 4.5 amp; sec #2 - 450V CT at 75 ma; working voltage to ground, pri 165V - RMS test 500V, sec #1 - 10V - RMS test 500V, sec #2 - 320 V - RMS test 900V; hermetically sealed rectangular case; 3" lg x 2 1/4" wd x 3 3/4" high excl term; seven 1/2" high standoff term; four No. 8-32 x 1/4" lg mtg bolts on 2" x 2 1/4" mtg/c; Spec. MIL-T-27, Grade 1, Class A, Family 03.	Power Transformer			(25) 107-B-309	107-B-309	T201	1	
<b>Terminal Boards</b>									
TB101	BOARD, terminal; resistor, capacitor, Xtal diode mounting board; 66 standoff lug term; XXX phenolic rectangular board, .093" thk; 6 1/4" lg x 4" wd; four .128" diam holes on 1.750" x 5.125" mtg/c.	Audio and metering terminal board			(25) 107-C-650	107-C-650	TB101	1	
TB102	BOARD, terminal; 5 feed-through lug term; XXX phenolic rectangular board, .093" thk; 1 1/2" lg x 1/2" wd; two .104" diam holes on 3/2" mtg/c.	PF filters output			(25) 107-B-651	107-B-651	TB102	1	
TB103	BOARD, terminal; resistor, capacitor, choke mounting board; 5 feed-through lug term; 4 standoff lug term; XXX phenolic board .093" thk; irregular shape; 3 1/2" lg x 2 1/4" wd o/a; two .128" diam holes on 1 1/4" mtg/c.	RF bracket (terminal board assy)			(25) 107-B-720	107-B-720	TB103	1	
<b>Electron Tubes</b>									
V101	ELECTRON TUBE: R.F pentode; Spec. MIL-E-1.	Carrier oscillator	6AH6				V101, 102, 107	3	
V102	Same as V101.	Buffer stage							
V103	ELECTRON TUBE: power pentode; Spec. MIL-E-1.	Output amplifier	6AG7				V103	1	
V104	ELECTRON TUBE: double-diode Spec. MIL-E-1.	Carrier volt meter	5726/6ALSW/6097				V104	1	
V105	ELECTRON TUBE: pentagrid Spec. MIL-E-1.	Crystal calibrator	5750/6BE6W				V105	1	

COMPONENT VALUES  
OSCILLATOR TRANSFORMER ASSEMBLY

BAND		T <sub>A</sub>	C <sub>A</sub>	C <sub>B</sub>	C <sub>C</sub>	R <sub>A</sub>	R <sub>B</sub>	J <sub>A</sub>
FREQ.	SYM. REF.							
10-26KC	Z101	T102	C146 4-30	C147 47	C148 470	R168 1 MEG	R169 22K	SHORT
26-75KC	Z102	T103	C149 4-30	C150 22	C151 470	R170 470K	R171 10K	SHORT
75-220KC	Z103	T104	C152 4-30	C153 15	C154 390	R172 330K	R173 6.8K	SHORT
220-600KC	Z104	T105	C155 4-30	C156 33	C157 270	R174 100K	R175 4.7K	SHORT
0.6-1.5MC	Z105	T106	C158 3-13	C159 7	C160 100	R176 100K	R177 3.3K	OPEN
1.5-3.8MC	Z106	T107	C161 3-13	C162 15	C163 270	R178 47K	SHORT	OPEN
3.8-10MC	Z107	T108	C164 3-13	C165 10	C166 220	R179 15K	SHORT	OPEN
10-25MC	Z108	T109	C167 3-13	C168 15	C169 100	R180 10K	SHORT	OPEN
25-50MC	Z109	T110	C170 3-13	C171 15	C172 220	R181 4.7K	SHORT	OPEN

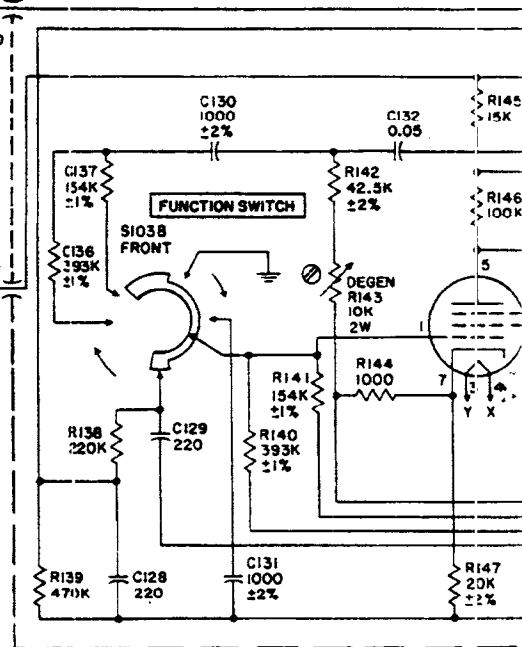
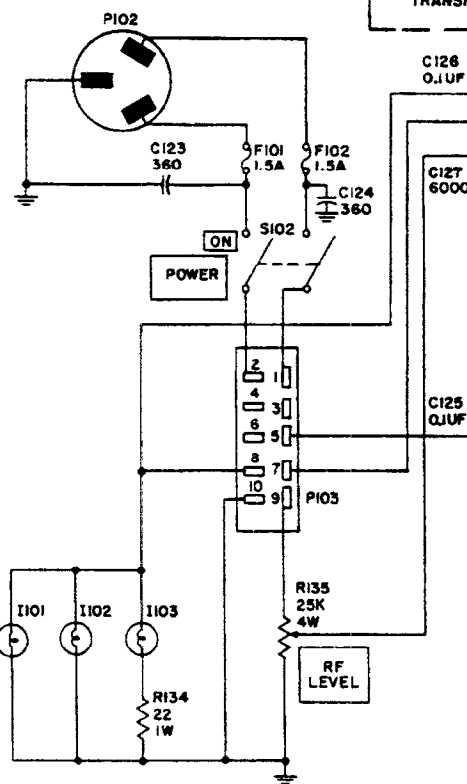
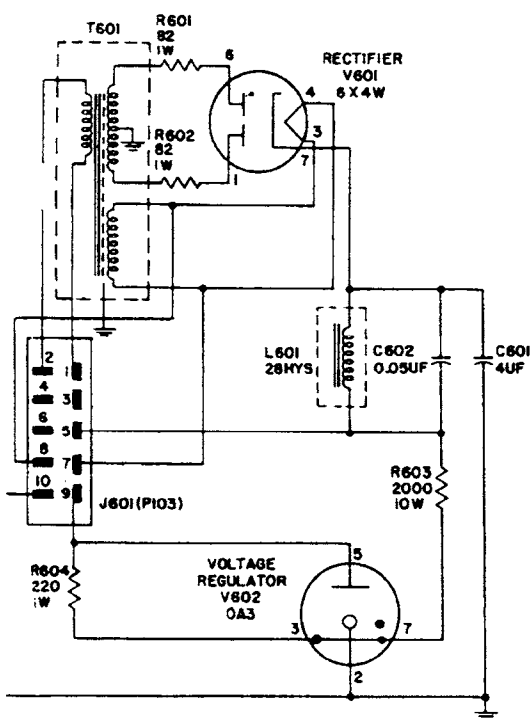
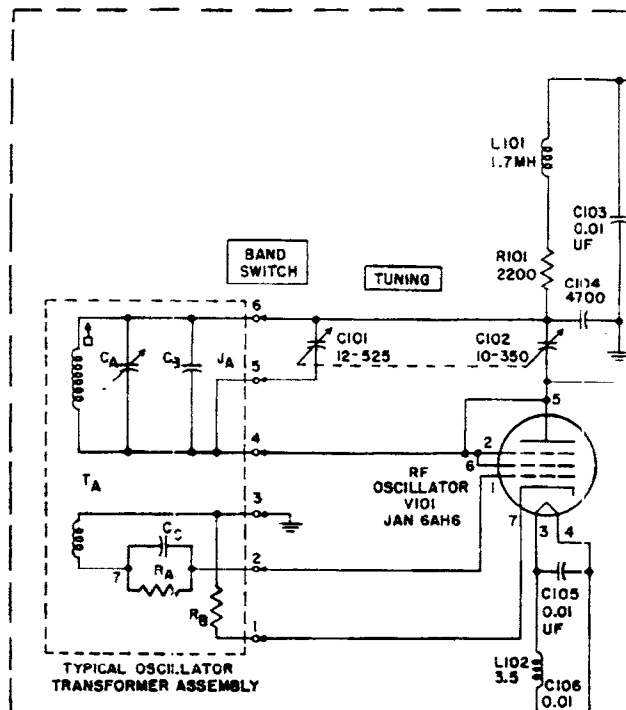

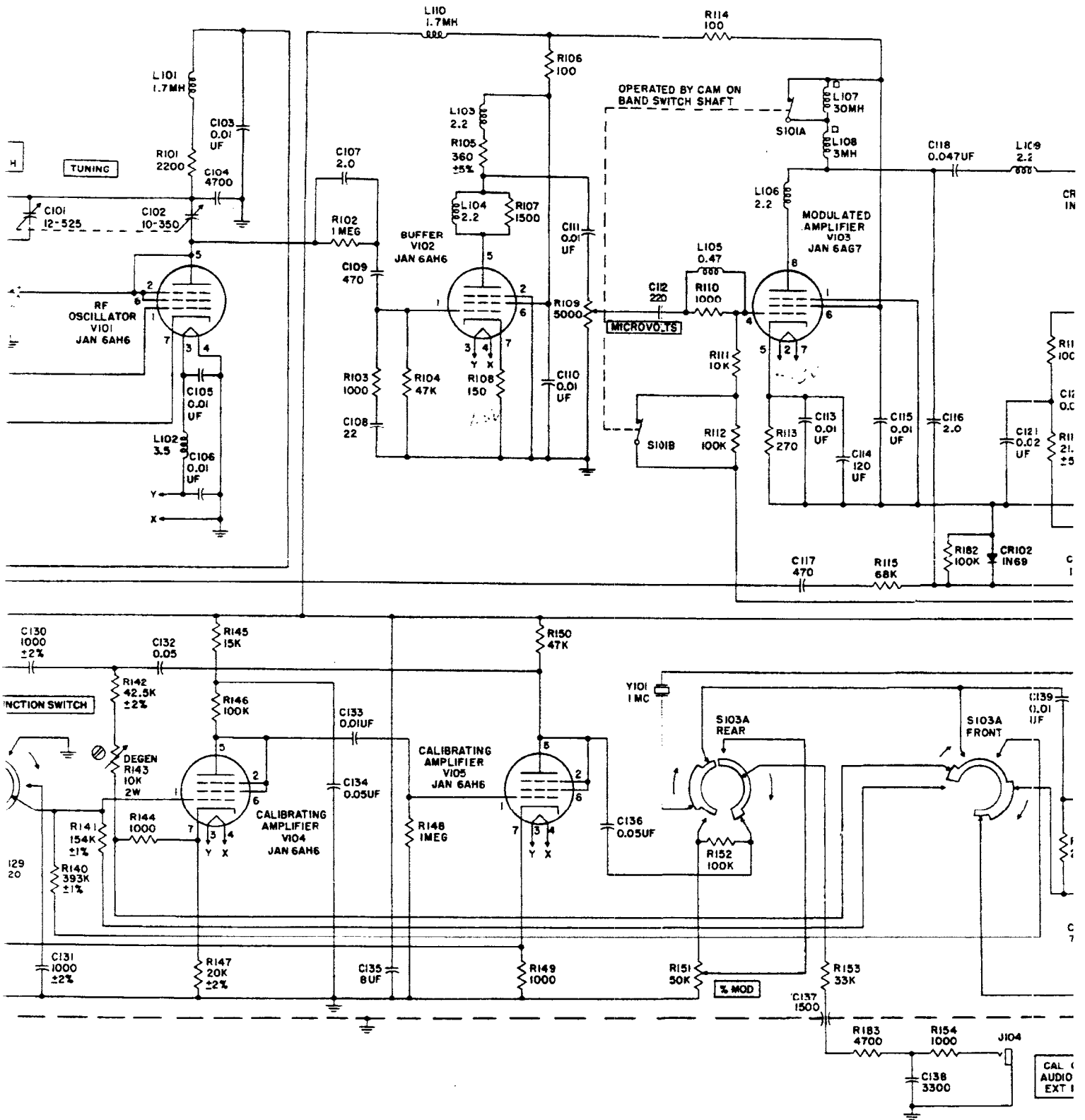

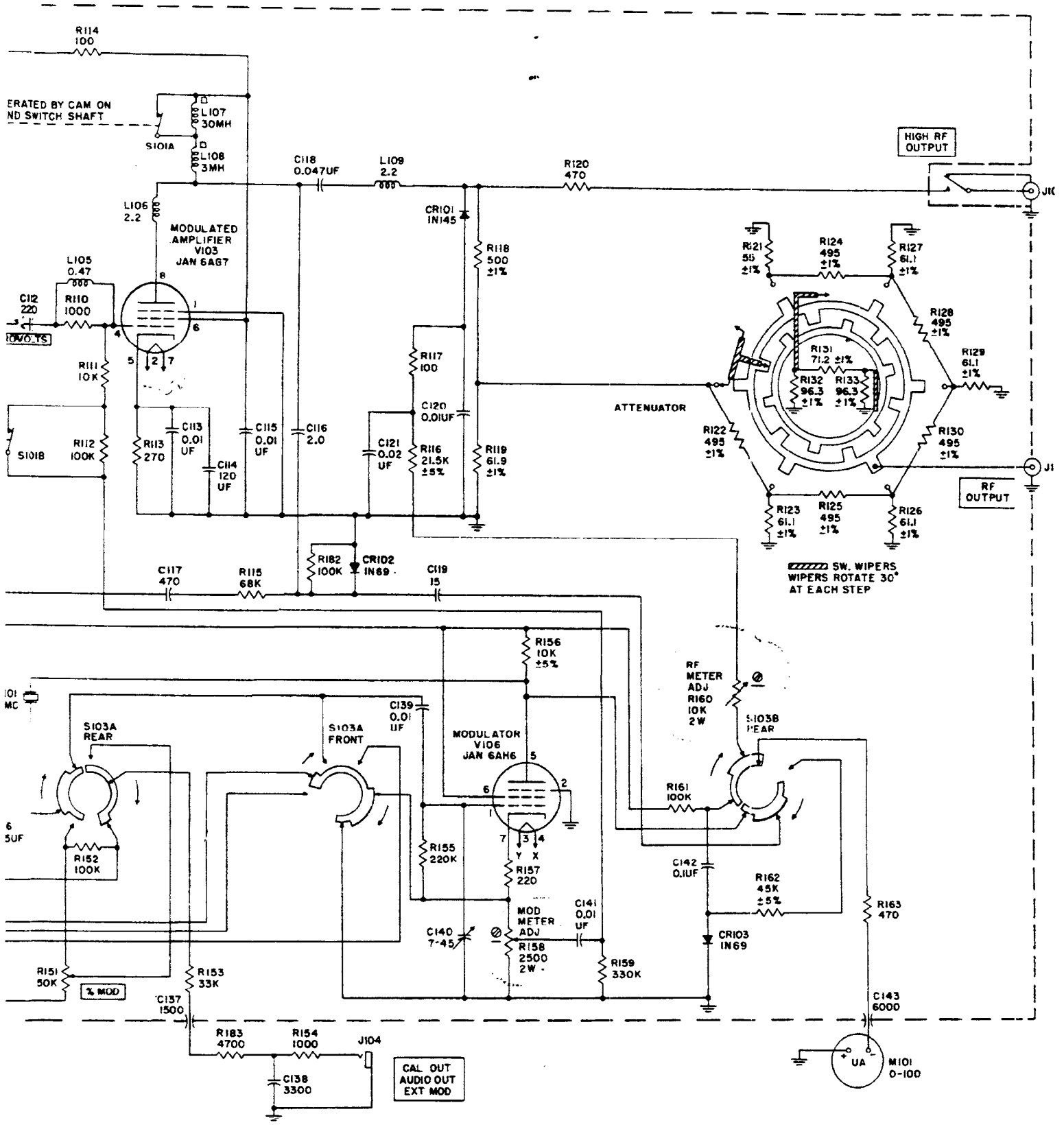
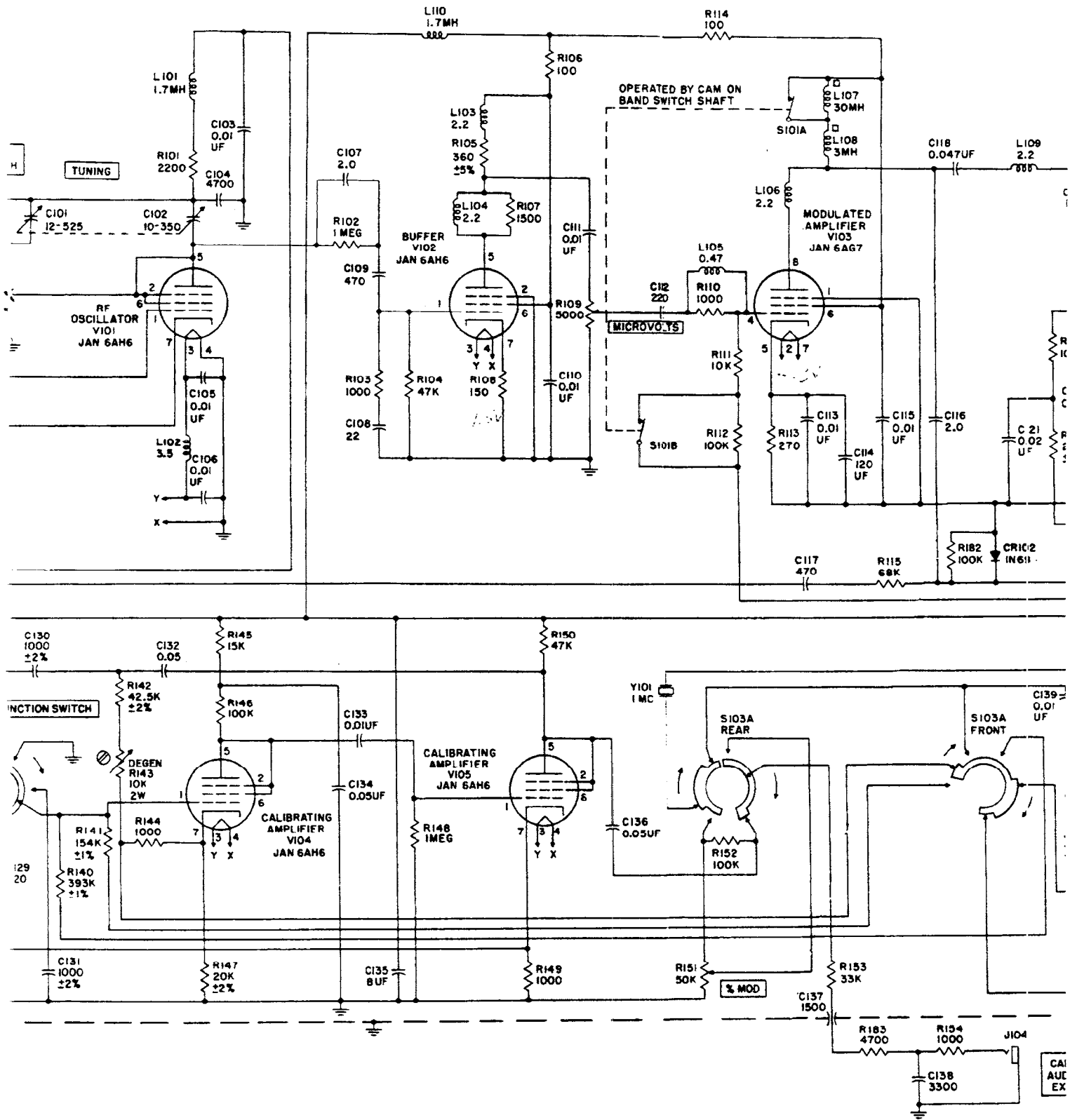

Figure 7-14. RF Signal Generator





**SECTION 8  
PARTS LISTS**

TABLE 8-1. LIST OF MAJOR UNITS

SYMBOL GROUP	NAME OF MAJOR UNIT	DESIGNATION
100-199	Generator, Signal	SG-103/URM-25F
200-299	Network, Impedance Matching	CU-406/URM-25F
300-399	Dummy, Load, Electrical	DA-109/URM-25F
400-499	Network, Impedance Matching	CU-408/URM-25F
500-599	Lead, Test	CX-2919/U
600-699	Power Supply	PP-1322/URM-25F
700-799	Cover, Signal Generator	CW-346/URM-25F

TABLE 8-2. TABLE OF REPLACEABLE PARTS

Reference Desig.	Stock Numbers Signal Corps Standard Navy Air Force	Name and Description	Locating Function
C100	---	TUNER, RADIO FREQUENCY: variable capacitor tuning; 10 kc to 50 mc frequency range, nine bands 3-1/2 in. lg, 3-1/4 in. w, 2-7/8 in. deep; composed of C100A, O115, O116, O117, O118, O119, O120, O121, O122, O123, O124, O125, O126, O127, NLIC Dwg No. 162-C-344.	Continuous frequency control
C100A	---	CAPACITOR, VARIABLE ASSEMBLY: 10 kc to 50 mc frequency range, nine bands 4-23/32 in. lg, 3-3/16 in. w, 1-27/32 in. high, includes capacitor drive housing.	Variable capacitor p/o C100
C101	For reference only	CAPACITOR, VARIABLE AIR DIELECTRIC: plate-meshing type 1 section, 0 uuf to 11.0 uuf capacity, no trimmers included, shaft adjustment 180° clockwise rotation of plates, part of C100A assembly.	Section of C100A
C102	For reference only	CAPACITOR, VARIABLE DIELECTRIC: plate-meshing type 1 section, 0 to 14.5 uuf capacity, no trimmers included, shaft adjustment 180° clockwise rotation of plates, part of C100A assembly.	Section of C100A
C103	R16JAN- CK63Y103Z N16-C-19140-9591 ---	CAPACITOR, FIXED, CERAMIC DIELECTRIC: 10,000 uuf +100 -20% tolerance, 500 vdcw, +300 -700 uuf per uf insulated; 3/4 in. dia, 5/32 in. thk; MIL-C-11015A, CK63Y103Z.	V101 Plate decoupling
C104	---	CAPACITOR, FIXED, MICA DIELECTRIC: 1 section, 500 vdcw, 4700 uuf, ±10% tolerance, style No. 22, MBCA Ref Dwg Group 1; low-loss plastic case; 53/64 in. lg, 53/64 in. w, 11/32 in. high; JAN-C-5, CM35B472K.	V101 Plate decoupling
C105		Same as C103.	V101 Filament decoupling
C106		Same as C103.	V101 Filament decoupling
C107	---	CAPACITOR, FIXED, CERAMIC DIELECTRIC: 500 vdcw, 2 uuf 0.25 uf tolerance, case style No. 1, MBCA Ref Dwg Group 1; -330 parts per million per deg C, uninsulated; 0.400 in. lg, 0.200 in. dia; JAN-C-20A, CC20SK020C.	V101 Plate coupling
C108	---	CAPACITOR, FIXED, CERAMIC DIELECTRIC: 22 uuf, 0.25 uuf tolerance, case style No. 1, MBCA Ref Dwg Group 1; -330 parts per million per deg C, uninsulated; 0.400 in. lg, 0.200 in. dia, JAN-C-20A, CC20SH220J.	V102 Grid shunt
C109	For replacement use SNSN N16-C-016140-8550 ---	CAPACITOR, FIXED, MICA DIELECTRIC: 500 vdcw, 470 uuf, ±5% tolerance, case style No. 22, MBCA Ref Dwg Group 1, low-loss plastic, ±100 parts per million per deg C; 51/64 in. lg, 15/32 in. w, 7/32 in. high, JAN-C-5, CM20D471J.	V102 Grid coupling
C110		Same as C103.	V102 Decoupling
C111		Same as C103.	V102 Plate coupling
C112	---	CAPACITOR, FIXED, MICA DIELECTRIC: 500 vdcw, 220 uuf, ±10% tolerance, case style No. 22, MBCA Ref Dwg Group 1, low-loss plastic; 51/64 in. lg, 15/32 in. w, 7/32 in. high, JAN-C-5, CM20B221K.	V103 Grid coupling
C113		Same as C103.	V103 RF cathode bypass

TABLE 8-2. TABLE OF REPLACEABLE PARTS

Reference Desig.	Stock Numbers Signal Corps Standard Navy Air Force	Name and Description	Locating Function
C114	--- For replacement use SNSN N16-C-020259-7500 ---	CAPACITOR, FIXED, ELECTROLYTIC: 1 section, 25 vdcw, 120 uf capacity, -20°C to +65°C working temp range, case style No. 16, MBCA Ref Dwg Group 1, metal case, hermetically sealed; 1-3/4 in. lg, 1 in. dia, JAN-C-62, CE31E121F.	V103 Audio cathode bypass
C115		Same as C103.	V103 Decoupling capacitor
C116		Same as C107.	Calibrator RF coupling
C117	--- N16-C-30114-4276 3330-37603-4800	CAPACITOR, FIXED, MICA DIELECTRIC: 500 vdcw, 470 uuf, ±10% tolerance, case style No. 22, MBCA Ref Dwg Group 1, low-loss plastic; 51/64 in. lg, 15/32 in. w, 7/32 in. high, JAN-C-5, CM20B471K.	Calibrator audio coupling
C118	--- --- ---	CAPACITOR, FIXED, PAPER DIELECTRIC: 1 section, 400 vdcw, 47,000 uuf, ±20% tolerance, case style No. 2, MBCA Ref Dwg Group 1, metal case, hermetically sealed; 13/16 in. lg, 0.4 in. dia, GUC XGS2268-20, NLIC Dwg No. 162-A-441.	Output coupling
C119	--- N16-C-015988-1600 ---	CAPACITOR, FIXED, CERAMIC DIELECTRIC: 15 uuf capacity +5% tolerance, 500 vdcw, -330 parts per million per deg C; 0.400 in. lg, 0.200 in. dia, JAN-C-20A, CC20SH150J.	Crystal calibrator coupling
C120		Same as C103.	RF meter bypass
C121	--- N16-C-011008-0500 ---	CAPACITOR, FIXED, PAPER DIELECTRIC: 1 section, 100 vdcw, 20,000 uuf, ±20% tolerance, case style No. 2, MBCA Ref Dwg Group 1, metal case, hermetically sealed; 1 in. lg, 23/64 in. dia, JAN-C-25, CP16A1HB203M.	RF meter bypass
C122		Not used.	
C123	--- N16-C-017973-1354 ---	CAPACITOR, FIXED, CERAMIC DIELECTRIC: 1 section, 500 vdcw, 360 uuf, ±5% tolerance, -750 parts per million per deg C, case style No. 1, MBCA Ref Dwg Group 1, insulated, 1.326 in. lg, 0.340 in. dia, JAN-C-20A, CC36UJ361J.	Line bypass
C124		Same as C123.	Line bypass
C125	--- N16-C-045801-9324 3330-0572-51184	CAPACITOR, FIXED, PAPER DIELECTRIC: 1 section, 400 vdcw, 130 v ac, 0.1 ufd capacity per section, case style No. 18, MBCA Ref Dwg Group 1, metal case, hermetically sealed, 1-13/16 in. lg, 11/16 in. dia, SPR Part No. 80P1, NLIC Dwg No. 162-A-442.	B+ feed-through
C126		Same as C125.	Filament feed-through
C127	--- --- ---	CAPACITOR, FEED-THROUGH: 1 section, 500 vdcw, 6000 uuf GMV, case style No. 4, MBCA Ref Dwg Group 1, metal case, 3/4 in. lg, 5/16 in. w, ERC 327-6000 uuf, NLIC Dwg No. 162-A-443-1.	Oscillator B+ feed-through
C128		Same as C112.	Calibrator filter condenser
C129		Same as C112.	Calibrator filter condenser

TABLE 8-2. TABLE OF REPLACEABLE PARTS

Reference Desig.	Stock Numbers Signal Corps Standard Navy Air Force	Name and Description	Locating Function
C130	--- N16-C-31080-2214 ---	CAPACITOR, FIXED, MICA DIELECTRIC: 1 section, 500 vdcw, 1000 uuf, +2% tolerance, ±100 parts per million per deg C, case style No. 22, MBCA Ref Dwg Group 1, molded low-loss case; 53/64 in. lg, 53/64 in. w, 9/32 in. high, JAN-C-5, CM30D102G.	Audio oscillator frequency determination
C131		Same as C130.	Audio oscillator frequency determination
C132	--- N16-C-44289-8652 3330-31770439	CAPACITOR, FIXED, PAPER DIELECTRIC: 1 section, 600 vdcw, 50,000 uuf, ±20% tolerance, case style No. 2, MBCA Ref Dwg Group 1, metal case, hermetically sealed; 1-11/16 in. lg, 11/16 in. dia, JAN-C-25, CP26A1EF503M.	Audio oscillator coupling capacitor
C133	--- N16-C-42767-6196 ---	CAPACITOR, FIXED, PAPER DIELECTRIC: 1 section, 600 vdcw, 10,000 uuf, ±20% tolerance, case style No. 2, MBCA Ref Dwg Group 1, metal case, hermetically sealed; 1-5/16 in. lg, 1/2 in. dia, JAN-C-25, CP26A1EF103M.	V104 Plate coupling
C134		Same as C132.	V104 Decoupling
C135	R16JAN-CP70E1EF 805V N16-C-051501-9840 3330-317371-340	CAPACITOR, FIXED, PAPER DIELECTRIC: 1 section, 600 vdcw, 8 uuf, +10 -20% tolerance, case style No. 34, MBCA Ref Dwg Group 1, metal case, hermetically sealed; 3-3/4 in. lg, 1-1/4 in. w, 4-1/4 in. high, JAN-C-25, CP70E1EF805V.	B+ filter
C136		Same as C132.	V105 Plate coupling
C137	--- For replacement use SNSN N16-C-018787-8062 ---	CAPACITOR, FEED-THROUGH: 1 section, 500 vdcw, 1500 uuf, ±20% tolerance, case style No. 4, MBCA Ref Dwg Group 1, metal case, 3/4 in. lg, 5/16 in. w, ERC 327-1500 uuf, NLIC Dwg 162-A-443-2.	Audio output feed-through
C138	--- N16-C-018961-1550 ---	CAPACITOR, FIXED, CERAMIC DIELECTRIC: 1 section, 500 vdcw, 3300 uuf, +10 -20% tolerance, variable temp coefficient, insulated, 3/4 in. dia, 5/32 in. thk, MIL-C-11015A, CK62Y332Z.	Audio output RF filter
C139	--- N16-C-042762-5424 ---	CAPACITOR, FIXED, PAPER DIELECTRIC: 1 section, 100 vdcw, 10,000 uuf, ±20% tolerance, case style No. 2, MBCA Ref Dwg Group 1, metal case, hermetically sealed; 13/16 in. lg, 23/64 in. dia, JAN-C-25, CP16A1HB103M.	V103 Grid coupling
C140	--- N16-C-64133-6581 3330-313420185	CAPACITOR, VARIABLE, CERAMIC DIELECTRIC: rotary, 1 section, 7.0 to 45.0 uuf capacity, 500 vdcw, Ref Dwg Group 204, section A, No. 2; 27/32 in. lg, 41/64 in. w, 13/32 in. deep, JAN-C-81, CV11C450.	Crystal shunt
C141		Same as C139.	V103 Modulated coupling
C142	--- N16-C-045807-8094 3330-316777500	CAPACITOR, FIXED, PAPER DIELECTRIC: 1 section, 600 vdcw, 100,000 uuf, ±20% tolerance, case style No. 2, MBCA Ref Dwg Group, metal case, hermetically sealed; 2-1/16 in. lg, 11/16 in. dia, JAN-C-25, CP26A1EF104M.	Audio metering coupling
C143		Same as C122.	Meter feed-through
C144		Not used.	L111 Filter
C145		Not used.	L111 Filter

TABLE 8-2. TABLE OF REPLACEABLE PARTS

Reference Desig.	Stock Numbers Signal Corps Standard Navy Air Force	Name and Description	Locating Function
C146	--- N16-C-064062-6985 ---	CAPACITOR, VARIABLE, CERAMIC DIELECTRIC: 1 section, 4 to 30 uuf, 500 vdcw, MBCA Ref Dwg Group 204, section A, No. 2; 27/32 in. lg, 41/64 in. w, 13/32 in. deep, JAN-C-81, CV11C300.	RF oscillator trimmer
C147	--- For replacement use SNSN N16-C-016525-2573 ---	CAPACITOR, FIXED, CERAMIC DIELECTRIC: 500 vdcw, 47 uuf, -750 parts per million per deg C, ±5% tolerance, case style No. 1, MBCA Ref Dwg Group 1, uninsulated, 0.400 in. lg, 0.200 in. dia, JAN-C-20A, CC20UJ470J.	RF oscillator compensating
C148		Same as C109.	RF oscillator grid coupling
C149		Same as C146.	RF oscillator trimmer
C150	--- N16-C-016149-1215 ---	CAPACITOR, FIXED, CERAMIC DIELECTRIC: 500 vdcw, 22 uuf, ±5% tolerance, -750 parts per million per deg C, case style No. 1, MBCA Ref Dwg Group 1, uninsulated, 0.400 in. lg, 0.200 in. dia, JAN-C-20A, CC20UJ220J.	RF oscillator compensating
C151		Same as C109.	RF oscillator grid coupling
C152		Same as C146.	RF oscillator trimmer
C153	--- N16-C-015989-1215 ---	CAPACITOR, FIXED, CERAMIC DIELECTRIC: 500 vdcw, 15 uuf, ±5% tolerance, -750 parts per million per deg C, case style No. 1, MBCA Ref Dwg Group 1, uninsulated, 0.400 in. lg, 0.200 in. dia, JAN-C-20A, CC20UJ150J.	RF oscillator compensating
C154	--- N16-C-029898-3608 ---	CAPACITOR, FIXED, MICA DIELECTRIC: 1 section, 500 vdcw, 390 uuf, ±5% tolerance, -100 to +100 parts per million per deg C, case style No. 22, MBCA Ref Dwg Group 1, low-loss plastic, 51/64 in. lg, 15/32 in. w, 7/32 in. high, JAN-C-5, CM20D391J.	RF oscillator grid coupling
C155		Same as C146.	RF oscillator trimmer
C156	--- N16-C-016309-1215 ---	CAPACITOR, FIXED, CERAMIC DIELECTRIC: 500 vdcw, 33 uuf, ±5% tolerance, -750 parts per million per deg C, case style No. 1, MBCA Ref Dwg Group 1, uninsulated, 0.400 in. lg, 0.200 in. dia, JAN-C-20A, CC20UJ330J.	RF oscillator compensating
C157	--- N16-C-29608-2206 ---	CAPACITOR, FIXED, MICA DIELECTRIC: 1 section, 500 vdcw, 270 uuf, ±5% tolerance, -100 to +100 parts per million per deg C, case style No. 22, MBCA Ref Dwg Group 1, low-loss plastic, 51/64 in. lg, 15/32 in. w, 7/32 in. high, JAN-C-5, CM20D271J.	RF oscillator grid coupling
C158	--- N16-C-63965-2800 3330-313050138	CAPACITOR, VARIABLE, CERAMIC DIELECTRIC: 1 section, rotary, 3.0 uuf to 13.0 uuf, 500 vdcw, 27/32 in. lg, 41/64 in. w, 13/32 in. deep, JAN-C-81, CV11B130.	RF oscillator trimmer
C159	--- For replacement use SNSN N16-C-015753-7072 ---	CAPACITOR, FIXED, CERAMIC DIELECTRIC: 500 vdcw, 7 uuf, ±0.5 uuf tolerance, -750 parts per million per deg C, case style No. 1, MBCA Ref Dwg Group 1, uninsulated, 0.400 in. lg, 0.200 in. dia, JAN-C-20A, CC20UJ070D.	RF oscillator compensating

TABLE 8-2. TABLE OF REPLACEABLE PARTS

Reference Desig.	Stock Numbers Signal Corps Standard Navy Air Force	Name and Description	Locating Function
C160	--- N16-C-028553-1206 ---	CAPACITOR, FIXED, MICA DIELECTRIC: 1 section, 500 vdcw, 100 uuf, ±5% tolerance, -100 to +100 parts per million per deg C, case style No. 2, MBCA Ref Dwg Group 1, low-loss plastic; 51/64 in. lg, 15/32 in. w, 7/32 in. high, JAN-C-5, CM20D101J.	RF oscillator grid coupling
C161		Same as C158.	RF oscillator trimmer
C162		Same as C153.	RF oscillator compensating
C163		Same as C157.	RF oscillator grid coupling
C164		Same as C158.	RF oscillator trimmer
C165	--- N16-C-015917-2572 ---	CAPACITOR, FIXED, CERAMIC DIELECTRIC: 500 vdcw, 10 uuf, ±0.5 uuf tolerance, -750 parts per million per deg C, case style No. 1, MBCA Ref Dwg Group 1, uninsulated; 0.400 in. lg, 0.200 in. dia, JAN-C-20A, CC20UJ100D.	RF oscillator compensating
C166	--- N16-C-029370-7606 ---	CAPACITOR, FIXED, MICA DIELECTRIC: 1 section, 500 vdcw, 2.0 uuf, ±5% tolerance, -100 to +100 parts per million per deg C, case style No. 22, MBCA Ref Dwg Group 1, low-loss plastic; 51/64 in. lg, 15/32 in. w, 7/32 in. high, JAN-C-5, CM20D221J.	RF oscillator grid coupling
C167		Same as C158.	RF oscillator trimmer
C168		Same as C153.	RF oscillator compensating
C169		Same as C160.	RF oscillator grid coupling
C170		Same as C158.	RF oscillator trimmer
C171		Same as C153.	RF oscillator compensating
C172		Same as C166.	RF oscillator grid coupling
CR101	--- N16-T-051760-0005 ---	CRYSTAL UNIT, RECTIFYING: 1 unit, germanium type, Military, 1N145 to MIL-E-1/811 (Navy).	RF meter diode
CR102	--- N16-T-051769-0000 ---	CRYSTAL UNIT, RECTIFYING: 1 unit, germanium type, MIL-E-1B, JAN-1N69.	Calibration detector
CR103		Same as CR102.	Percentage modulation meter diode
E101	--- Low Failure Item - if required requisition from ESO referencing Nav Ships 900-180A ---	KNOB: set screw type; 1-1/8 in. lg, 3/4 in. w, 5/8 in. high, for 1/4 in. dia shaft, natural colored body, arrow marking, WAEQ K105, NLIC Dwg 162-A-369.	RF level knob
E102		Same as E101.	Attenuator knob
E103		Same as E101.	Function switch
E104		Same as E101.	Percent modulation
E105		Same as E101.	Microvolt control

TABLE 8-2. TABLE OF REPLACEABLE PARTS

Reference Desig.	Stock Numbers Signal Corps Standard Navy Air Force	Name and Description	Locating Function
E106	--- Low Failure Item - if required requisition from ESO referencing Nav Ships 900-180A ---	KNOB: set screw type; 2-1/4 in. lg, 1-1/2 in. w, 1 in. high, natural colored body, for 1/2 in. shaft, arrow marking, NLIC Dwg 162-B-212.	Band change knob
E107	--- Low Failure Item - if required requisition from ESO referencing Nav Ships 900-180A ---	DIAL VERNIER: knob type, engraved 0 to 100 left to right, linear range, for 1/4 in. shaft, dim. 1-3/4 in. dia, 1 in. high, NLIC Dwg 162-B-238.	Tuning control
E108	--- --- ---	TURRET SECTION ASSEMBLY: p/o RF Oscillator Assembly, 7 contact points, brass, silver plated, 1/8 in. dia, 1/2 in. lg, over-all dim. 2-5/8 in. lg, 2-1/8 in. w, 7/8 in. high, NLIC Dwg 162-D-047.	Makes contact for and holds frequency coils
E109		Same as E108.	Makes contact for and holds frequency coils
E110		Same as E108.	Makes contact for and holds frequency coils
E111		Same as E108.	Makes contact for and holds frequency coils
E112		Same as E108.	Makes contact for and holds frequency coils
E113		Same as E108.	Makes contact for and holds frequency coils
E114		Same as E108.	Makes contact for and holds frequency coils
E115		Same as E108.	Makes contact for and holds frequency coils
E116		Same as E108.	Makes contact for and holds frequency coils
E117	--- --- ---	CONTACT ASSEMBLY ELECTRICAL: p/o RF Oscillator circuit, 6 points, copper silver plated; 5/32 in. high, 9/16 in. lg, over-all dim. 2-1/8 in. lg, 1 in. w, 5/32 in. high, NLIC Dwg 162-B-354.	Makes contact to frequency range coils
E118	--- Low Failure Item - if required requisition from ESO referencing Nav Ships 900-180A ---	CONTACT ELECTRICAL: grounding contacts for frequency turret, 1 point, silver plated; 9/16 in. lg, 5/32 in. w, over-all dim. 2-1/32 in. lg, 5/32 in. w, 15/32 in. high, NLIC Dwg 162-D-124-9.	Makes contact to frequency range coil

TABLE 8-2. TABLE OF REPLACEABLE PARTS

Reference Desig.	Stock Numbers Signal Corps Standard Navy Air Force	Name and Description	Locating Function
E119		Same as E118.	Makes contact to frequency range coil
E120	--- N16-S-034607-6039 ---	SHIELD ELECTRON TUBE: accommodates RMA tube envelope style 5-3, straight cylinder shape, open top, vented, brass, over-all dim. 2-1/4 in. lg, 0.930 in. dia, mounts on tube socket, JAN-S-28A, TS102U03.	Tube shield
E121	--- N16-S-034557-8351 ---	SHIELD ELECTRON TUBE: accommodates RMA tube envelope style 5-2, straight cylinder type, open top, vented, brass, over-all dim. 1-3/4 in. lg, 0.930 in. dia, mounts directly on tube socket, JAN-S-28S, TS102U02.	Tube shield
E122		Same as E121.	Tube shield
E123		Same as E121.	Tube shield
E124		Same as E121.	Tube shield
E125		Same as E121.	Tube shield
E126		Not used.	
E127	--- --- ---	CONTACT GROUNDING: p/o attenuator, 2 contact points, phosphor bronze, silver plated contact surface, over-all dim. 1-5/16 in. lg, 5/16 in. w, 1/8 in. high, NLIC Dwg 162-A-282.	Attenuator ground
E128		Same as E127.	Attenuator ground
E129		Same as E127.	Attenuator ground
E130	--- --- ---	ROTOR, WIPER PLATE: over-all dim. 2-5/8 in. dia, 1/2 in. high, NLIC Dwg 162-B-287.	Makes contact for attenuator
E131	--- --- ---	CONTACT ASSEMBLY, LOWER: p/o attenuator, 6 points silver plated, 3/32 in. dia, 0.023 in. high, over-all dim. 2-5/8 in. dia, 1/16 in. thk, NLIC Dwg 162-B-228.	Mounts and provides contact for attenuator resistors
E132	--- --- ---	CONTACT RING: copper, natural finish, saucer shaped, over-all dim. 2.745 in. dia, 1/8 in. thk, mounts in snug-fitting shoulder, NLIC Dwg 162-B-029.	Attenuator switch plate
E133	--- Low Failure Item - if required requisition from ESO referencing Nav Ships 900-180A ---	CLAMP, ELECTRICAL: cold rolled steel Cd plated, fastened by No. 6 machine screw, over-all dim. 7/16 in. high, 1 in. lg, 13/16 in. w, approx designed to hold electron tube, NLIC Dwg 162-A-416.	V103 Tube hold-down clamp
E134		Not used.	
F101	--- G16-F-016302-0090 ---	FUSE, CARTRIDGE: 1.5 amps, 250 v, AC instantaneous, ferrule type, glass, one time, non-indicating, 1-1/4 in. lg, 1/4 in. dia, BUS HKP-BEHJ, NLIC Dwg 162-A-458, MIL-F-15160, FO2G1R50A.	Primary power fuse



TABLE 8-2. TABLE OF REPLACEABLE PARTS

Reference Desig.	Stock Numbers Signal Corps Standard Navy Air Force	Name and Description	Locating Function
F102		Same as F101.	Primary power fuse
F103		Same as F101.	Primary spare fuse
F104		Same as F101.	Primary spare fuse
I101	--- GM17-L-005195-0000 ---	LAMP, INCANDESCENT: 6 to 8 v, 0.25 amp, white, 1 filament, tungsten, C-2R, 15/16 in. over-all lg over 25 hr rated life, Navy lamp TS-53 to BuShips Dwg 9-S-4222-L-30, GLEC 51.	Instrument lamp
I102		Same as I101.	Instrument lamp
I103		Same as I101.	Pilot lamp
J101	--- --- ---	CONNECTOR, RECEPTACLE: 1 contact, low-loss plastic, straight shape, 1-13/16 in. lg, 11/16 in. dia, w/enclosing shell, copper base alloy, corrosion resistant, precious metal plated, locking type, w/switch twist type, 1 mtg hole 1/2 in. dia body threaded 1/2 in.-28 threads, NLIC Dwg 162-C-361.	Jack for high RF output
J102	--- N17-C-073108-5259 ---	CONNECTOR, RECEPTACLE: 1 contact, low-loss plastic, straight shape, 1-1/16 in. lg, 1/2 in. dia, BNC type UG-1094/U, locking type, 1 mtg hole 0.432 in. dia, ALI Sig Corps Dwg No. SC-D-72305.	RF output jack
J103		Not used.	
J104	--- N17-J-039248-4418 ---	JACK, TELEPHONE: leaf contact arrangement J-1, MBCA Ref Dwg Group 4, 1-1/4 in. lg, 7/8 in. w, 3/4 in. high, 2 conductor, shank dim. 0.250 in. dia, 1.209 in. lg, JAN-J-641, JJ-034.	Audio output/input jack
L101	--- N16-C-076596-1365 R16-NLIC-162B111	CHOKE, RADIO FREQUENCY: 15 ma current rating, for use above 250 kc, 1 in. lg, 7/16 in. dia, NLIC Dwg 162-B-111.	V101 B+ filter choke
L102	--- N16-C-73117-7602 R16-NLIC-162-B116	CHOKE, RADIO FREQUENCY: 15 ma current rating, for use above 7.9 mc, 1 in. lg, 1/4 in. dia, NLIC Dwg 162-B-116.	V101 Filament filter choke
L103	--- Low Failure Item - if required requisition from ESO referencing Nav Ships 900-180A ---	CHOKE, RADIO FREQUENCY: 15 ma current rating, for use above 7.9 mc, 1/2 in. lg, 1/8 in. dia, NLIC Dwg 162-A-391.	V102 Series peaking coil
L104		Same as L103.	V102 Series peaking coil
L105	--- Low Failure Item - if required requisition from ESO referencing Nav Ships 900-180A ---	CHOKE, RADIO FREQUENCY: 15 ma current rating, for use above 7.9 mc, 1/2 in. lg, 1/8 in. dia, NLIC Dwg 162-A-392.	V102 Grid peaking control

TABLE 8-2. TABLE OF REPLACEABLE PARTS

Reference Desig.	Stock Numbers Signal Corps Standard Navy Air Force	Name and Description	Locating Function
L106		Same as L103.	V102 Series peaking coil
L107	--- N16-C-074438-8989 ---	CHOKE, RADIO FREQUENCY: 15 ma current rating, for use above 7.9 kc, 1-7/8 in. lg, 5/8 in. dia, NLIC Dwg 162-B-109.	V104 Plate circuit B+ feed choke
L108	--- N16-C-071362-7077 ---	CHOKE, RADIO FREQUENCY: 15 ma for use above 250 kc, 1-7/8 in. lg, 1/2 in. dia, NLIC Dwg 162-B-107.	V104 Plate circuit B+ feed choke
L109		Same as L103.	V102 Series peaking coil
L110		Same as L101.	B+ RF filter choke
M101	--- N17-M-029352-2959 ---	MULTIMETER: 1 to 10 uv 2 steps, 5 to 50% modulation, 1 step, $\pm 2\%$ accuracy, basic meter size, 2-1/2 in. dia max, 100 micro-amp sensitivity, over-all dim. 2.695 in. dia, 2.74 in. deep, BUI P35X2753, NLIC Dwg 162-C-045.	RF level and modulation meter
O101	--- Shop Manufacture ---	CLAMP, ELECTRICAL: steel, painted, two No. 6-32 bolts, 4-7/8 in. lg, 1-11/32 in. w; to hold capacitor 4-1/4 in. high; NLIC Dwg 162-B-167.	Hold down device for C135
O102	--- Low Failure Item - if required requisition from ESO referencing Nav Ships 900-180A ---	DIAL SCALE, ASSEMBLY: kc and mc, 10 kc to 50 mc, 9 bands, range of inscription is non-linear; 45 in. effective scale length, 6-5/8 in. dia, 3/32 in. thk, 5/8 in. dia, center hole; NLIC Dwg 162-B-205.	Indicates frequency setting of generator
O103	--- G41-W-2445-2 ---	WRENCH: hex type, 1/16 in. across flats, 1-27/32 in. w; hex handle; 90° offset, ALN No. 6.	Fits No. 6 Allen screw
O104	--- G41-W-2444-5 ---	WRENCH: hex type, .050 in. across flats, 1-27/32 in. w; hex handle; 90° offset; ALN No. 4.	Fits No. 4 Allen screw
O105	--- Low Failure Item - if required requisition from ESO referencing Nav Ships 900-180A ---	DIAL, INDEX: fixed line type; illuminated 6-3/4 in. lg, 3-7/16 in. w, 1/16 in. thk; NLIC Dwg 162-B-298.	Fixed dial index
O106	--- Shop Manufacture ---	BOLT, THUMB: steel, corrosion resistant finished, cylindrical slot; 1/8 in. high, 3/8 in. dia; No. 12 thread, nominal length 7/8 in., Class 2 fit, 7/32 in. min lg, NLIC Dwg 162-A-235.	Retains front panel
O107		Same as O106.	Retains front panel
O108		Same as O106.	Retains front panel
O109		Same as O106.	Retains front panel
O110		Same as O106.	Retains front panel
O111		Same as O106.	Retains front panel

TABLE 8-2. TABLE OF REPLACEABLE PARTS

Reference Desig.	Stock Numbers Signal Corps Standard Navy Air Force	Name and Description	Locating Function
O112	---	GASKET: neoprene, joint 1, Ref Dwg Group 76; diagonal cut Ref Dwg Group 76; nominal dim. 1/4 in. w, 1/2 in. high, 46 in. lg; NLIC Dwg 162-B-011.	Makes unit water-tight
O113	---	Not used.	
O114	---	Not used.	
O115	---	GEAR, WORM WHEEL: plain style, phosphor bronze alloy No. 610, 3/16 in. w face, 20° pressure angle, 0.833 pitch dia, used w/worm gear w/single thread, right hand helix angle of 4° 46'; 0.2502 in. bore dia, 5/8 in. dia hub, 1/2 in. lg hub bore, p/o C100 assembly; NLIC Dwg 162-A-338.	Drive for tuning capacitor
O116	N16-G-505001-0347	GEAR, WORM: straight type stainless steel material, single thread, 3/4 in. w face, 20° pressure angle, 1/2 in. pitch dia, 4° 46'; thread lead, right hand thread, 0.540 in. outside dia, mtg by 0.2363 in. dia shaft, p/o C100 assembly; NLIC Dwg 162-A-339.	Drive for tuning capacitor
O117	---	COUPLING, SHAFT, FLEXIBLE: phosphor bronze, HP not rated, 1-1/16 in. OD, 1/2 in. lg, for 1/4 in. shafts, p/o C100 assembly; NLIC Dwg 162-A-359.	Drive for tuning capacitor
O118	---	BEARING, BALL, THRUST: single row, grooved race surface, single direction, rigid, w/o seating ring, 0.2490 in. bore dia, 0.6250 in. max OD, 0.1969 in. max height, lubricated w/grease to Spec. MIL-G-3278, p/o C100 assembly; NIC4DS, NLIC Dwg 162-A-449.	Drive for tuning capacitor
O119	GM3110-156-4278	BEARING, BALL, THRUST: double row, concave race surface, double direction, rigid, 0.2362 in. bore dia, 0.7480 in. OD, 0.236 in. high, p/o C100 assembly; NH 13301; NLIC Dwg 162-A-448.	Drive for tuning capacitor
O120	For replacement use SNSN GM3110-100-6176	BALL, BEARING: chrome alloy steel, 3/16 in. dia, Rockwell D scale 60-70 hardness, Grade No. 2, p/o C100 assembly; HOV.	Drive for tuning capacitor
O121	Shop Manufacture	BRACKET, BEARING: composition No. 10 to Spec QQ-A-591, iridite finished, rectangular shape, 1-5/8 in. lg, 1-13/32 in. w, 1/4 in. thk, mtg by two 0.173 in. dia holes 1.312 in. c to c, p/o C100 assembly; NLIC Dwg 162-A-334.	Drive for tuning capacitor
O122	Shop Manufacture	BLOCK, BEARING: composition No. 10 to Spec QQ-A-591, iridite finished, rectangular shape, 31/32 in. lg, 0.687 in. w, 1/4 in. thk, mtg by four No. 2-56 tapped holes, p/o C100 assembly; NLIC Dwg 162-A-335.	Drive for tuning capacitor
O123	Low Failure Item - if required requisition from ESO referencing NAV Ships 900-180A	SPRING, LEAF: beryllium copper, Navy Spec 46C10, 1/2 hard, U shape, 1-1/4 in. lg, 3/4 in. w, 0.687 in. deep, 0.010 in. thk material, four 0.102 in. dia holes, four 1/8 by 9/32 in. mtg slots on bottom, p/o C100 assembly; NLIC Dwg 162-A-342.	Drive for tuning capacitor

TABLE 8-2. TABLE OF REPLACEABLE PARTS

Reference Desig.	Stock Numbers Signal Corps Standard Navy Air Force	Name and Description	Locating Function
O124	--- Shop Manufacture ---	PLATE, ALUMINUM: 52S hard per QQ-A-318b, iridite finished, square, 0.687 in. lg, 0.687 in. w, 0.064 in. thk, four 1/8 in. lg, 9/32 in. w, slots on 0.437 in. by 0.375 in. mtg centers, p/o C100 assembly; NLIC Dwg 162-A-343.	Drive for tuning capacitor
O125	--- Shop Manufacture ---	RETAINER: aluminum alloy type 2S-0, caustic etched 1/8 in. lg, 0.091 in. dia, p/o C100 assembly; NLIC Dwg 162-A-362.	Drive for tuning capacitor
O126	--- Shop Manufacture ---	RETAINER, BALL: corrosion resistant steel, A1S1 type 303, passivated, headless, 3/64 in. by 3/64 in. slotted drive, hollow point, 7/16 in. over-all lg, 5/16 in. -32 threaded entire lg, p/o C100 assembly; NLIC Dwg 162-A-358.	Drive for tuning capacitor
O127	--- Shop Manufacture ---	PLATE, STOP: aluminum alloy 52S hard per QQ-A-318b, iridite finished, 9/16 in. lg, 1/2 in. w, 0.064 in. thk, over-all, two 0.102 in. dia holes spaced 1/4 in. c to c, p/o C100 assembly; NLIC Dwg 162-A-363.	Drive for tuning capacitor
O128	G41-W-2446-2 --- ---	WRENCH: hex type, 5/64 in. across flat, 45/64 in. w, hex handle 1-31/32 in. lg, ALN No. 8.	Fits No. 4 Allen cap
P101		Not used.	
P102		Not used.	
P103	--- --- ---	CONNECTOR, PLUG, ELECTRICAL: 10 contacts, type MFE insulation to Spec MIL-P-14, rectangular shape; 1-19/32 in. lg, 1-21/32 in. high, 13/16 in. deep over-all; w/partially enclosing shell of ferrous metal iridite protected; contacts of phosphor bronze, polarized, non-locking; 1/2 in. dia max cable opening; NLIC Dwg 162-A-447.	Mates with J601
P104	--- --- ---	CONNECTOR, PLUG: 3 contacts, 1 connector mating end; glass filled dielectric; p/o W101, straight shape, 2-5/32 in. lg, 1-17/32 in. w, 15/16 in. thk, non-locking; accommodates cable up to 0.450 in. dia, cable clamp; AUTT 920.	Connector for power cable W101
P105	--- N17-C-71408-5333 ---	CONNECTOR, PLUG: 1 rd male contact, straight type connector; over-all dim., 31/32 in. lg, 9/16 in. dia; 52 ohms nominal impedance, non constant frequency impedance characteristic; cylinder body, brass, silver plated, locking type; molded teflon insert; 9/16 in. OD coupling nut; p/o W102, W103 and W104; AN type UG-88/U Navy Dwg RE49F246 IPC 1200.	Connector for power cable W102, W103 and W104
R101	--- N16-R-50012-811 3350-098000-3651	RESISTOR, FIXED, COMPOSITION: body style No. 3, MBCA Ref Dwg Group 2; 2200 ohms ±10% tolerance, 1/2 w; characteristic F; 0.406 in. lg, 0.175 in. dia; insulated; JAN-R-11, RC20BF222K.	V101 Plate filtering
R102	--- N16-R-050975-0811 3350-098000-6671	RESISTOR, FIXED, COMPOSITION: body style No. 3, MBCA Ref Dwg Group 2; 1 meg ±10% tolerance, 1/2 w; characteristic F; 0.406 in. lg, 0.175 in. dia; insulated; JAN-R011, RC20BF105K.	Coupling shunt resistor
R103	--- N16-R-049922-0811 ---	RESISTOR, FIXED, COMPOSITION: body style No. 3, MBCA Ref Dwg Group 2; 1000 ohms ±10% tolerance, 1/2 w; characteristic F; 0.406 in. lg, 0.175 in. dia; insulated; JAN-R-11, RC20BF102K.	V102 Grid bias
R104	--- N16-R-50480-811 3350-098000-5131	RESISTOR, FIXED, COMPOSITION: body style No. 3, MBCA Ref Dwg Group 2; 47,000 ohms, ±10% tolerance, 1/2 w; characteristic F; 0.406 in. lg, 0.175 in. dia; insulated; JAN-R-11, RC20BF473K.	V102 Grid bias

TABLE 8-2. TABLE OF REPLACEABLE PARTS

Reference Desig.	Stock Numbers Signal Corps Standard Navy Air Force	Name and Description	Locating Function
R105	--- N16-R-049723-0431 3350-098000-2791	RESISTOR, FIXED, COMPOSITION: body style No. 3, MBCA Ref Dwg Group 2; 360 ohms, $\pm 5\%$ tolerance, 1/2 w; characteristic F; 0.406 in. lg, 0.175 in. dia; insulated; JAN-R-11, RC20BF361J.	V102 Plate peaking
R106	--- N16-R-49580-811 3350-098000-2271	RESISTOR, FIXED, COMPOSITION: body style No. 3, MBCA Ref Dwg Group 2; 100 ohms, $\pm 10\%$ tolerance, 1/2 w; characteristic F; 0.406 in. lg, 0.175 in. dia; insulated; JAN-R-11, RC20BF101K.	V102 Decoupling resistor
R107	--- N16-R-49967-811 ---	RESISTOR, FIXED, COMPOSITION: body style No. 3, MBCA Ref Dwg Group 2; 1500 ohms, $\pm 10\%$ tolerance, 1/2 w; characteristic F; 0.406 in. lg, 0.175 in. dia; insulated; JAN-R-11, RC20BF152K.	V102 Plate damper
R108	--- N16-R-49625-811 ---	RESISTOR, FIXED, COMPOSITION: body style No. 3, MBCA Ref Dwg Group 2; 150 ohms, $\pm 10\%$ tolerance, 1/2 w; characteristic F; 0.406 in. lg, 0.175 in. dia; insulated; JAN-R-11, RC20BF151K.	V102 Cathode resistor
R109	R16JAN-RV3ATFD 502A For replacement use SNSN N16-R-087518-7670 3350-769500-2275	RESISTOR, VARIABLE COMPOSITION: 1 section; 5000 ohms, $\pm 10\%$ tolerance, 1/2 w; std A taper, MBCA Ref Dwg Group 3; metal case, enclosed; 1-9/32 in. dia, 21/32 in. deep; single shaft, metal, rd; 1/4 in. dia, 7/8 in. lg, from mtg center; high torque; supplied w/o sw; CPH Type CA1737 per NLIC Dwg 162-A-444; JAN-R-94, RV3ATFD502A.	Microvolt control
R110		Same as R103.	V103 Grid coupling damper
R111	--- N16-R-50282-811 3350-098000-4391	RESISTOR, FIXED, COMPOSITION: body style No. 3, MBCA Ref Dwg Group 2; 10,000 ohms, $\pm 10\%$ tolerance, 1/2 w; characteristic F; 0.406 in. lg, 0.175 in. dia; insulated; JAN-R-11, RC20BF103K.	V103 Grid resistor
R112	--- N16-R-50633-811 3350-098000-5451	RESISTOR, FIXED, COMPOSITION: body style No. 3, MBCA Ref Dwg Group 2; 100,000 ohms, $\pm 10\%$ tolerance, 1/2 w; characteristic F; 0.406 in. lg, 0.175 in. dia; insulated; JAN-R-11, RC20BF104K.	V103 Grid resistor
R113	--- N16-R-49688-811 ---	RESISTOR, FIXED, COMPOSITION: body style No. 3, MBCA Ref Dwg Group 2; 270 ohms, $\pm 10\%$ tolerance, 1/2 w; characteristic F; 0.406 in. lg, 0.175 in. dia; insulated; JAN-R-11, RC20BF271K.	V103 Cathode resistor
R114		Same as R106.	V103 Decoupling resistor
R115	--- N16-R-50552-811 3350-098000-5291	RESISTOR, FIXED, COMPOSITION: body style No. 3, MBCA Ref Dwg Group 2; 68,000 ohms, $\pm 10\%$ tolerance, 1/2 w; characteristic F; 0.406 in. lg, 0.175 in. dia; insulated; JAN-R-11, RC20BF683K.	Calibrator filter resistor
R116	--- For replacement use SNSN N16-R-050369-0788 ---	RESISTOR, FIXED, FILM: body style No. 3, MBCA Ref Dwg Group 2; 21,500 ohms, $\pm 5\%$ tolerance, 1/2 w; temp coefficient 0.05% per deg C; 1/2 in. lg, 5/32 in. dia; MIL-R-10509A, RN15X2152J.	Fixed RF meter resistor
R117		Same as R106.	Fixed RF meter resistor

TABLE 8-2. TABLE OF REPLACEABLE PARTS

Reference Desig.	Stock Numbers Signal Corps Standard Navy Air Force	Name and Description	Locating Function
R118	--- For replacement use SNSN N16-R-072953-8841 ---	RESISTOR, FIXED, FILM: body style No. 3, MBCA Ref Dwg Group 2; 500 ohms, $\pm 1\%$ tolerance, 1/2 w; temp coefficient 0.05% per deg C; 1/2 in. lg, 5/32 in. dia, ETR DC1/2C; performance to MIL-R-10509A, RN15X5000F, NLIC Dwg 162-A-445-1.	Attenuator series resistor
R119	--- N16-R-072869-4209 ---	RESISTOR, FIXED, FILM, body style No. 3, MBCA Ref Dwg Group 2; 61.9 ohms, $\pm 1\%$ tolerance, 1/2 w; temp coefficient 0.05% per deg C; 1/2 in. lg, 5/32 in. dia; MIL-R-10509A, RN15X61R9F.	Attenuator shunt resistor
R120	--- N16-R-49769-811 3350-098000-2911	RESISTOR, FIXED, COMPOSITION: body style No. 3, MBCA Ref Dwg Group 2; 470 ohms, $\pm 10\%$ tolerance, 1/2 w; characteristic E; 0.406 in. lg, 0.175 in. dia; insulated; JAN-R-11, RC20BF471K.	High output coupling resistor
R121	--- N16-R-72862-5322 ---	RESISTOR, FIXED, FILM: body style No. 3, MBCA Ref Dwg Group 2; 55.0 ohms, $\pm 1\%$ tolerance, 1/2 w; temp coefficient 0.05% per deg C; 1/2 in. lg, 5/32 in. dia; ETR DC1/2C; performance to MIL-R-10509A, RN15X55R0F, NLIC Dwg 162-A-445-2.	Step attenuator resistor
R122	--- N16-R-72952-8301 ---	RESISTOR, FIXED, FILM: body style No. 3, MBCA Ref Dwg Group 2; 495 ohms, $\pm 1\%$ tolerance, 1/2 w; temp coefficient 0.05% per deg C; 1/2 in. lg, 5/32 in. dia, ETR DC1/2C; performance to MIL-R-10509a, RN15X4950F, NLIC Dwg 162-A-445-3.	Step attenuator resistor
R123	--- For replacement use SNSN N16-R-872868-3301 ---	RESISTOR, FIXED, FILM, body style No. 3, MBCA Ref Dwg Group 2; 61.1 ohms, $\pm 1\%$ tolerance, 1/2 w; temp coefficient 0.05% per deg C; 1/2 in. lg, 5/32 in. dia, ETR DC1/2C; performance to MIL-R-10509a, RN15X6121F, NLIC Dwg 162-A-445-3.	Step attenuator resistor
R124		Same as R122.	Step attenuator resistor
R125		Same as R122.	Step attenuator resistor
R126		Same as R123.	Step attenuator resistor
R127		Same as R123.	Step attenuator resistor
R128		Same as R122.	Step attenuator resistor
R129		Same as R123.	Step attenuator resistor
R130		Same as R122.	Step attenuator resistor
R131	--- N16-R-073181-4594 ---	RESISTOR, FIXED, FILM: body style No. 3, MBCA Ref Dwg Group 2; 71.2 ohms, $\pm 5\%$ tolerance, 1/2 w; temp coefficient 0.05% per deg C; 1/2 in. lg, 5/32 in. dia, ETR DC1/2C; performance to MIL-R-10509a, RN15X71R2F, NLIC Dwg 162-A-445-5.	Step attenuator resistor

TABLE 8-2. TABLE OF REPLACEABLE PARTS

Reference Desig.	Stock Numbers Signal Corps Standard Navy Air Force	Name and Description	Locating Function
R132	--- --- ---	RESISTOR, FIXED, FILM: body style No. 3, MBCA Ref Dwg Group 2; 96.3 ohms, $\pm 1\%$ tolerance, 1/2 w; temp coefficient 0.05 per deg C; 1/2 in. lg, 5/32 in. dia, ETR DC1/2C; performance to MIL-R-10509a, RN15X96R3F, NLIC Dwg 162-A-445-6.	Step attenuator resistor
R133		Same as R132.	Step attenuator resistor
R134	--- N16-R-49320-231 ---	RESISTOR, FIXED, COMPOSITION: body style No. 3, MBCA Ref Dwg Group 2; 22 ohms, $\pm 10\%$ tolerance, 1 w; characteristic E; 0.750 in. lg, 0.280 in. dia; insulated; JAN-R-11, RC30BF220K.	Indicator lamp series resistor
R135	--- --- ---	RESISTOR, VARIABLE WIRE-WOUND: 1 section; 25,000 ohms, $\pm 10\%$ tolerance, 4 w; std A taper, MBCA Ref Dwg Group 3; metal case enclosed; 1.78 in. dia, 0.98 in. deep; metal shaft, rd w/flat 1/4 in. dia, 7/8 in. lg, high torque w/o switch; JAN-R-19 type; CPH CA1301, NLIC Dwg 162-A-440.	RF level control
R136	--- For replacement use SNSN N16-R-073259-6551 ---	RESISTOR, FIXED, FILM: body style No. 3, MBCA Ref Dwg Group 2; 393,000 ohms, $\pm 1\%$ tolerance, 1/2 w; temp coefficient 0.05% per deg C; 1/2 in. lg, 5/32 in. dia, ETR DC1/2C; performance to MIL-R-10509a, RN15X3933F, NLIC Dwg 162-A-445-7.	Audio oscillator frequency determination
R137	--- For replacement use SNSN N16-R-073210-1346 ---	RESISTOR, FIXED, FILM: body style No. 3, MBCA Ref Dwg Group 2; 154,000 ohms $\pm 1\%$ tolerance, 1/2 w; temp coefficient 0.05% per deg C; 1/2 in. lg, 5/32 in. dia, MIL-R-10509A, RN15X1543F.	Audio oscillator frequency determination
R138	--- N16-R-50714-811 3350-098000-5781	RESISTOR, FIXED, COMPOSITION: body style No. 3, MBCA Ref Dwg Group 2; 220,000 ohms, $\pm 10\%$ tolerance, 1/2 w; characteristic E; 0.406 in. lg, 0.175 in. dia; insulated; JAN-R-11, RC20BF224K.	Calibrator filter resistor
R139	--- N16-R-050822-0811 ---	RESISTOR, FIXED, COMPOSITION: body style No. 3, MBCA Ref Dwg Group 2; 470,000 ohms, $\pm 10\%$ tolerance, 1/2 w; characteristic F; 0.406 in. lg, 0.175 in. dia; insulated; JAN-R-11, RC20BF474K.	Calibrator filter resistor
R140		Same as R136.	Audio oscillator frequency determination
R141		Same as R137.	Audio oscillator frequency determination
R142	--- N16-R-073140-8033 ---	RESISTOR, FIXED, FILM: body style No. 3, MBCA Ref Dwg Group 2; 42,500 ohms, $\pm 2\%$ tolerance, 1/2 w; temp coefficient 0.05 per deg C; 1/2 in. lg, 5/32 in. dia, ETR DC1/2C; performance per MIL-R-10509A, RN15X4252G, NLIC Dwg 162-A-445-8.	Fixed degeneration
R143	--- N16-R-091291-4985 ---	RESISTOR, VARIABLE, WIRE-WOUND: 1 section, 10,000 ohms, $\pm 10\%$ tolerance, 2 w; std A taper, MBCA Ref Dwg Group 3; metal case, enclosed; 1.28 in. dia, 0.62 in. deep, metal shaft, rd slotted, 1/2 in. from mtg surface, normal torque; w/o switch; JAN-R-19, RA20A1SA103 AK.	Degeneration control
R144		Same as R103.	V104 Cathode resistor

TABLE 8-2. TABLE OF REPLACEABLE PARTS

Reference Desig.	Stock Numbers Signal Corps Standard Navy Air Force	Name and Description	Locating Function
R145	--- N16-R-050336-0811	RESISTOR, FIXED, COMPOSITION: body style No. 3, MBCA Ref Dwg Group 2; 15,000 ohms, $\pm 10\%$ tolerance, 1/2 w; characteristic F; 0.406 in. lg, 0.175 in. dia; insulated; JAN-R-11, RC20BF153K.	V104 Plate decoupling
R146		Same as R112.	V104 Plate load
R147	--- N16-R-073112-5324	RESISTOR, FIXED, FILM: style No. 3, MBCA Ref Dwg Group 2; 20,000 ohms, $\pm 2\%$ tolerance, 1/2 w; temp coefficient 0.05% per deg C; 1/2 in. lg, 5/32 in. dia, ETR DC1/2C; performance to MIL-R-10509a, RN15X2002G, NLIC Dwg 162-A-445-9.	V104 Cathode resistor
R148		Same as R102.	V105 Grid resistor
R149		Same as R103.	V105 Cathode resistor
R150		Same as R104.	V105 Plate load
R151	--- For replacement use SNSN N16-R-87849-4747	RESISTOR, VARIABLE COMPOSITION: 1 section, 50,000 ohms, $\pm 10\%$ tolerance, 1/2 w; std A taper, MBCA Ref Dwg Group 3; metal case, enclosed, 1-9/32 in. dia, 21/32 in. deep; metal shaft rd; w/flat 7/8 in. from mtg surface; normal torque; w/o switch; JAN-R-94, FV3ATFD503A.	Percentage modulation control
R152		Same as R112.	V105 Plate coupling resistor
R153	--- N16-R-050417-0811	RESISTOR, FIXED, COMPOSITION: body style No. 3, MBCA Ref Dwg Group 2; 33,000 ohms, $\pm 10\%$ tolerance, 1/2 w; characteristic F; 0.406 in. lg, 0.175 in. dia; insulated; JAN-R-11, RC20BF333K.	RF filter audio out
R154		Same as R103.	RF filter audio out
R155		Same as R138.	V106 Grid resistor
R156	--- For replacement use SNSN N16-R-050281-0616	RESISTOR, FIXED, FILM: body style No. 3, MBCA Ref Dwg Group 2; 10,000 ohms, $\pm 5\%$ tolerance, 1/2 w; temp coefficient 0.05% per deg C; 1/2 in. lg, 5/32 in. dia; MIL-R-10509A, RN15X1002J.	V106 Plate load
R157	--- N16-R-049661-0811	RESISTOR, FIXED, COMPOSITION: body style No. 3, MBCA Ref Dwg Group 2; 220 ohms, $\pm 10\%$ tolerance, 1/2 w; characteristic F; 0.406 in. lg, 0.175 in. dia; JAN-R-11, RC20BF221K.	V106 Cathode resistor
R158	--- N16-R-090868-2980	RESISTOR, VARIABLE, WIRE-WOUND: 1 section, 2500 ohms, $\pm 10\%$ tolerance, 2 w; std A taper, MBCA Ref Dwg Group 3; metal case, enclosed, 1.28 in. dia, 0.68 in. deep; metal shaft, rd, slotted, 1/2 in. lg from mtg surface, normal torque; w/o switch; JAN-R-94, RA20A1SA252AK.	Pre-set percent modulation
R159	--- N16-R-50759-811 3350-098000-5891	RESISTOR, FIXED, COMPOSITION: body style No. 3, MBCA Ref Dwg Group 2; 330,000 ohms, $\pm 10\%$ tolerance, 1/2 w; characteristic F; 0.406 in. lg, 0.175 in. dia; insulated; JAN-R-11, RC20BF334K.	V106 Modulation fixed resistor
R160		Same as R143.	RF meter adjustment



TABLE 8-2. TABLE OF REPLACEABLE PARTS

Reference Desig.	Stock Numbers Signal Corps Standard Navy Air Force	Name and Description	Locating Function
R161		Same as R112.	Isolation resistor for audio metering circuit
R162	--- For replacement use SNSN N16-R-073144-7226 ---	RESISTOR, FIXED, FILM: body style No. 3, MBCA Ref Dwg Group 2; 45,000 ohms, $\pm 5\%$ tolerance, 1/2 w; temp coefficient 0.05% per deg C; 1/2 in. lg, 5/32 in. dia, ETR DC1/2C; performance to MIL-R-10509A, RN15X4502E, NLIC Dwg 162-A-445-10.	Fixed modulation meter resistor
R163		Same as R120.	RF filter resistor
R164		Not used.	
R165		Not used.	
R166		Not used.	
R167		Not used.	
R168		Same as R102.	Oscillator grid resistor
R169	--- N16-R-50372-811 3350-098000-4711	RESISTOR, FIXED, COMPOSITION: body style No. 3, MBCA Ref Dwg Group 2; 22,000 ohms, $\pm 10\%$ tolerance, 1/2 w; characteristic E; 0.406 in. lg, 0.175 in. dia; insulated; JAN-R-11, RC20BF223K.	Oscillator cathode resistor
R170		Same as R139.	Oscillator grid resistor
R171		Same as R111.	Oscillator cathode resistor
R172		Same as R159.	Oscillator grid resistor
R173	--- N16-R-050201-0811 ---	RESISTOR, FIXED, COMPOSITION: body style No. 3, MBCA Ref Dwg Group 2; 6800 ohms, $\pm 10\%$ tolerance, 1/2 w; characteristic E; 0.406 in. lg, 0.175 in. dia; insulated; JAN-R-11, RC20BF682K.	Oscillator cathode resistor
R174		Same as R112.	Oscillator grid resistor
R175	--- N16-R-50129-811 3350-098000-3971	RESISTOR, FIXED, COMPOSITION: body style No. 3, MBCA Ref Dwg Group 2; 4700 ohms, $\pm 10\%$ tolerance, 1/2 w; characteristic E; 0.406 in. lg, 0.175 in. dia; insulated; JAN-R-11, RC20BF472K.	Oscillator cathode resistor
R176		Same as R112.	Oscillator grid resistor
R177	--- N16-R-050066-0811 ---	RESISTOR, FIXED, COMPOSITION: body style No. 3, MBCA Ref Dwg Group 2; 3300 ohms, $\pm 10\%$ tolerance, 1/2 w; characteristic E; 0.406 in. lg, 0.175 in. dia; insulated; JAN-R-11, RC20BF332K.	Oscillator cathode resistor
R178		Same as R104.	Oscillator grid resistor
R179		Same as R145.	Oscillator grid resistor

TABLE 8-2. TABLE OF REPLACEABLE PARTS

Reference Desig.	Stock Numbers Signal Corps Standard Navy Air Force	Name and Description	Locating Function
R180		Same as R111.	Oscillator grid resistor
R181		Same as R175.	Oscillator grid resistor
R182		Same as R112.	Calibrator detector load
R183		Same as R175.	RF filter audio out
S101	---	SWITCH, LEVER, CAM: 2 lever positions; locking; 1st position - 2b, 2nd position - 2a, MBCA Ref Dwg Group 4; 125 v, 5 amp; 1-3/4 in. lg, 9/16 in. w, 7/8 in. high; 4 terminals, solder lug type, NLIC Dwg 162-B-277.	Modulator audio circuit sw
S102	---	SWITCH, TOGGLE: DPST, over-all dim. 1-21/64 in. max lg, 49/64 in. w, 1 in. deep; bat type handle, 11/16 in. lg excluding lg of bushing; toggle lock, JAN-S-23, ST52K.	Power off/on switch
S103	N17-S-072828-2605 ---	SWITCH, ROTARY: 2 sections, 5 positions, max of switching positions possible; non pile-up type; 12 fixed contacts; physical dim., 3/4 in. lg, 1-1/4 in. w, 1-5/16 in. high; flatted type shaft, 13/16 in. lg, 1/4 in. dia, NLIC Dwg 162-B-002.	Audio osc and cryst calibration function sw
T101		Not used.	
T102	---	TRANSFORMER, RADIO, FREQUENCY: 10 to 26 kc, 2 windings, primary, 300 uh at 1000 cycles, 700 turns ea of 7 pies, No. 38 AWG; 90 ohms DC resistance, untapped; 2-1/4 in. lg, 13/16 in. dia; primary tuned, adj iron core located axially, NLIC Dwg 162-C-030.	RF osc transformer 10 to 26 kc
T103	---	TRANSFORMER, RADIO, FREQUENCY: 26 to 75 kc, 2 windings, primary, 43 uh at 1 kc, 380 turns on ea of 6 pies; No. 36 AWG wire, 175 ohms DC resistance, untapped, secondary, 420 turns on single pie, No. 36 AWG wire, 35 ohms resistance AC, untapped; 2-1/4 in. lg, 13/16 in. dia; primary tuned, adj iron core, located axially, NLIC Dwg 162-C-031.	RF osc transformer 26 to 75 kc
T104	---	TRANSFORMER, RADIO, FREQUENCY: 75 to 220 kc, 2 windings, primary, 5 uh at 1 kc; 155 turns on ea of 5 pies, No. 34 AWG wire, 36 ohms DC resistance, untapped; secondary, 200 turns on single pie, No. 34 AWG wire, 10 ohms DC resistance untapped; 2-1/4 in. lg, 11/16 in. dia; primary tuned, adj iron core, NLIC Dwg 162-C-032.	RF osc transformer 75 to 220 kc
T105	---	TRANSFORMER, RADIO, FREQUENCY: 220 to 600 kc, 2 windings, primary, 605 uh at 1 kc, 60 turns on ea of 4 pies, No. 34 AWG wire, 12 ohms DC resistance, untapped; secondary, 110 turns on single pie, No. 34 AWG wire, 6 ohms DC resistance, untapped; 2-1/4 in. lg, 5/8 in. dia; primary tuned, adj iron core, NLIC Dwg 162-C-033.	RF osc transformer 220 to 600 kc
T106	---	TRANSFORMER, RADIO, FREQUENCY: 0.6 to 1.5 mc, 2 windings, primary, 192 uh at 790 kc, 180 turns solenoid, No. 36 AWG wire, 12 ohms DC resistance, untapped; secondary, 70 turns single pie, No. 36 AWG wire, 6 ohms DC resistance, untapped; 2-1/4 in. lg, 5/8 in. dia; primary tuned, adj iron core, NLIC Dwg 162-C-034.	RF osc transformer 0.6 to 1.5 mc

TABLE 8-2. TABLE OF REPLACEABLE PARTS

Reference Desig.	Stock Numbers Signal Corps Standard Navy Air Force	Name and Description	Locating Function
T107	--- --- ---	TRANSFORMER, RADIO, FREQUENCY: 1.5 to 3.8 mc, 2 windings, primary, 30 uh at 2.5 mc, 50 turns; No. 30 AWG wire, 2 ohms DC resistance, untapped; secondary, 6-2/3 turns, No. 30 AWG wire, untapped; 2-1/4 in. lg, 5/8 in. dia; primary tuned, adj iron core, NLIC Dwg 162-C-035.	RF osc transformer 1.5 to 3.8 mc
T108	--- --- ---	TRANSFORMER, RADIO, FREQUENCY: 3.8 to 10 mc, 2 windings, primary, 5.2 uh at 7.9 mc, 19 turns, No. 24 AWG wire, untapped; secondary, 3-2/3 turns, No. 30 AWG wire, untapped; 2-1/4 in. lg, 5/8 in. dia; primary tuned, adj iron core, NLIC Dwg 162-C-036.	RF osc transformer 3.8 to 10 mc
T109	--- --- ---	TRANSFORMER, RADIO, FREQUENCY: 10 to 25 mc, 2 windings, primary, 0.73 uh at 25 mc, 7 turns, No. 20 AWG wire, untapped, secondary, 2-2/3 turns, No. 30 AWG wire, untapped; 2-1/4 in. lg, 5/8 in. dia; primary tuned, adj iron core, NLIC Dwg 162-C-037.	RF osc transformer 10 to 25 mc
T110	--- --- ---	TRANSFORMER, RADIO, FREQUENCY: 25 to 50 mc, 2 windings, primary, 2 uh at 25 mc, 3 turns, No. 20 AWG wire, untapped; secondary, 1-2/3 turns, No. 30 AWG wire, untapped; 2-1/4 in. lg, 5/8 in. dia; primary tuned, adj iron core, NLIC Dwg 162-C-038.	RF osc transformer 25 to 50 mc
TB101	--- Low Failure Item - if required requisition from ESO referencing Nav Ships 900-180A ---	TERMINAL BOARD: phenolic; incl 6 terminals, solder post type; approx 2-3/32 in. lg, 2-3/32 in. w, 3/32 in. thk; NLIC Dwg 162-A-375.	Holds and makes contact for resistors and capacitors
TB102	--- Low Failure Item - if required requisition from ESO referencing Nav Ships 900-180A ---	TERMINAL BOARD: phenolic; incl 5 terminals, solder post type; 2-7/16 in. lg, 1 in. w, 3/32 in. thk; NLIC Dwg 162-A-117.	Holds and makes contact for resistors and capacitors
TB103	--- Low Failure Item - if required requisition from ESO referencing Nav Ships 900-180A ---	TERMINAL BOARD: phenolic; incl 33 terminals, solder post type; 5-1/4 in. lg, 3-3/8 in. w, 3/32 in. thk; NLIC Dwg 162-C-195.	Holds and makes contact for resistors and capacitors
TB104	--- Low Failure Item - if required requisition from ESO referencing Nav Ships 900-180A ---	TERMINAL BOARD: phenolic; incl 18 terminals, solder post type; 4-3/4 in. lg, 1-1/2 in. w, 3/32 in. thk; NLIC Dwg 162-B-210.	Holds and makes contact for resistors and capacitors
TB105	--- Low Failure Item - if required requisition from ESO referencing Nav Ships 900-180A ---	TERMINAL BOARD: phenolic; incl 7 terminals, solder post type; 2-15/16 in. lg, 15/16 in. w, 3/32 in. thk; NLIC Dwg 162-A-211.	Holds and makes contact for resistors and capacitors

TABLE 8-2. TABLE OF REPLACEABLE PARTS

Reference Desig.	Stock Numbers Signal Corps Standard Navy Air Force	Name and Description	Locating Function
TB106	--- Low Failure Item - if required requisition from ESO referencing Nav Ships 900-180A ---	TERMINAL BOARD: phenolic; incl 4 terminals, solder post type; 1-1/4 in. lg, 1 in. w, 3/32 in. thk; NLIC Dwg 162-A-400.	Holds and makes contact for resistors and capacitors
V101	--- N16-T-56186 ---	ELECTRON TUBE: glass envelope; RF amplifier, pentode; ML-E-1B, JAN-6AH6.	RF oscillator
V102		Same as V101.	Buffer
V103	--- N16-T-056177-0000 ---	ELECTRON TUBE: metal envelope; power amplifier, ML-E-1B, JAN-6AG7Y.	Modulated amplifier
V104		Same as V101.	Audio oscillator
V105		Same as V101.	Calibrator amplifier
V106		Same as V101.	Modulator
W101	--- Assemble from component parts ---	CABLE ASSEMBLY: power, electrical UNRL type SJ, 3 conductors, stranded, No. 18 AWG synthetic rubber insulated; polychloroprene sheath, 600 v RMS max rated working voltage; 6 ft over-all lg, 1 plug, AUTT 920 on one end, no terminal or fittings on second end, NLIC Dwg 162-B-048.	Input power cable
W102	--- Assemble from component parts ---	CORD, CG-409A/U: (4 ft 2 in.) type RG-58A/U coaxial, 52 ohms, characteristic impedance; single conductor, copper, stranded, 7 strands No. 20 AWG, 0.150 in. OD polyethylene dielectric, shield data; 1 copper tinned, black vinyl jacket, over-all lg, 50 in. excluding terminations, termination data; AN type, UG-88/U plug on ea end; NLIC Dwg 162-B-101.	Radio frequency output connecting cable
W103	--- Assemble from component parts ---	CORD, CG-409A/U: (6 in.) coaxial, 52 ohms, characteristic impedance; conductor data, copper tinned, stranded, 7 strands, No. 20 AWG, polyethylene dielectric, shield data, 1 copper, black vinyl jacket, type RG-58A/U, over-all lg, 6 in. lg, excluding terminations 4 in., termination data, AN plug type UG-88/U on ea end; NLIC Dwg 162-B-100.	RF cable for accessories
W104		Same as W103.	RF cable for accessories
W105	--- For replacement use SNSN N15-C-34954-8050 ---	CABLE POWER: 3 conductors, No. 18 AWG per strand; copper, 41 strand per conductor No. 34 AWG, tinned UNRL type SJ vinyl jacket, insulated; 600 volts ac max rated working voltage; rd cut, UNRL type SJ, 3 conductors p/o W101, NLIC Dwg 162-B-048-1.	Cable power p/o W101
W106	--- N15-C-12200-575 ---	CABLE, RADIO, FREQUENCY: single braid type; 52 ohms characteristic impedance 25.8 uuf capacitance per foot max; 1900 v root mean sq max operating voltage; single inner conductor, 0.0071 inch, copper tinned; 0.116 in. OD outer conductor, copper tinned; synthetic resin dielectric; black vinyl jacket; 0.195 in. over-all cross sectional dim.; p/o W102, W103 and W104; JAN-C-17A, RG-58A/U.	Cable radio frequency p/o W102, W103 and W104

TABLE 8-2. TABLE OF REPLACEABLE PARTS

Reference Desig.	Stock Numbers Signal Corps Standard Navy Air Force	Name and Description	Locating Function
XF101	--- N17-F-74267-5075 ---	FUSE HOLDER: extractor post type, 250 v, 15 amp; accommodates 1 cartridge type fuse, 1-1/4 in. lg, 1/4 in. dia; holder over-all 2-1/8 in. lg, 11/16 in. dia; BUS Type HKP-11, NLIC Dwg 162-A-458.	Retains fuse and makes contact
XF102		Same as XF101.	Retains fuse and makes contact
XI101	--- For replacement use SNSN N17-L-51633-4457 ---	LIGHT, PANEL: no lamp incl, miniature bayonet, bracket mounted on frame, on side of dial, 1-15/16 in. lg, 1/2 in. w, NLIC Dwg 162-B-130.	Lights tuning dial
XI102	--- --- ---	LIGHT, PANEL: no lamp incl, miniature bayonet type, bracket mounted on frame, on rear of dial, 1-15/16 in. lg, 1/2 in. w, NLIC Dwg 162-B-202.	Lights tuning dial
XI103	--- For replacement N17-L-76854-3991 ---	LIGHT, INDICATOR: supplied w/lens, 1/2 in. dia, red, smooth, screw mounted lens holder, accommodates G-3-1/2 lamp, miniature bayonet base, 2-1/16 in. lg, 15/16 in. dia, lamp replaceable from front of panel, DMC 50 Mil w/smooth red jewel, NLIC Dwg 162-A-460.	Indicates power-on
XV101	R16-S-4396-500 N16-S-062603-6702 ---	SOCKET, ELECTRON TUBE: section D, type E; molded plastic body, low-loss composition; 21/32 in. dia, hole rd shaped, plain; 25/32 in. lg, 0.800 in. dia; 2 mtg holes, provisions for mtg electron tube shield are provided, bayonet type, electron tube retaining device not incl, JAN-S-28A, TS102P01.	Holds and makes contact with tube
XV102		Same as XV101.	Holds and makes contact with tube
XV103	--- N16-S-063515-4151 ---	SOCKET, ELECTRON TUBE: section B, type B; molded plastic body, low-loss composition; 1-1/8 in. dia, chassis hole; 2 mtg holes spaced c to c, 1-7/8 in. lg, 1-3/8 in. w, 1/2 in. high; provisions for mtg electron tube shield are provided, bayonet type, electron tube retaining device not incl, JAN-S-28A, TS101P01.	Holds and makes contact with tube
XV104		Same as XV101.	Holds and makes contact with tube
XV105		Same as XV101.	Holds and makes contact with tube
XV106		Same as XV101.	Holds and makes contact with tube
XY101	--- For replacement use SNSN N16-S-054284-7281 ---	SOCKET CRYSTAL: 2 contacts regularly spaced, 0.094 in. dia, pins accommodated, spaced 0.487 in. c to c, brass contacts, silver plated, molded construction ceramic 55/64 in. lg, 3/8 in. high; solder lug type, no grounding lug data, body accommodation hole not required, 1 mtg hole in center, NF CH2C-4, NLIC Dwg 162-A-450.	Holds and makes contact for crystal
Y101	--- N16-C-096783-1861 ---	CRYSTAL, UNIT: Quartz, 1 plate incl, 1 mc, ±0.005% tolerance, -55 to 90°C fundamental, etched, Military, 0.720 in. lg, 0.768 in. high, 0.312 in. w, 1,000,000 kc, MIL, MIL-C-3098A, CR-18/U, REHO CR-18/U.	Calibrator crystal

TABLE 8-2. TABLE OF REPLACEABLE PARTS

Reference Desig.	Stock Numbers Signal Corps Standard Navy Air Force	Name and Description	Locating Function
J201	- - - - - - - - -	CONNECTOR, RECEPTACLE: 1 contact; low-loss plastic; straight shape; 1-1/16 in. lg, 1/2 in. dia; BNC type UG-1094/U, locking type, 1 mtg hole 0.432 in. dia, SIG Corps Dwg SC-D-72305. (Same as J102)	Coaxial input jack for impedance matching network
J202		Same as J201.	Coaxial input jack for impedance matching network
R201	- - - N16-R-049444-0431 - - -	RESISTOR, FIXED, COMPOSITION: body style No. 3, MBCA Ref Dwg Group 2; 51 ohms, $\pm 5\%$ tolerance; 1/2 w; characteristic F; 0.406 in. lg, 0.175 in. dia, insulated, JAN-R-11, RC20BF510J.	Primary termination resistor

TABLE 8-2. TABLE OF REPLACEABLE PARTS

Reference Desig.	Stock Numbers Signal Corps Standard Navy Air Force	Name and Description	Locating Function
C301	--- N16-C-029265-3006 3330-376013590	CAPACITOR, FIXED, MICA DIELECTRIC: 1 section, 500 vdcw, 200 uuf, ±5% tolerance, -100 to +100 parts per million per deg C, temp coefficient, case style No. 22, MBCA Ref Dwg Group 1, low-loss plastic, 51/64 in. lg, 5/32 in. w, 7/32 in. high, JAN-C-5, CM20D201J.	DA109 filter network capacitors
C302	--- N16-C-029898-3606 ---	CAPACITOR, FIXED, MICA DIELECTRIC: 1 section, 500 vdcw, 390 uuf, ±5% tolerance, -100 to +100 parts per million per deg C, case style No. 22, MBCA Ref Dwg Group 1, low-loss plastic, 51/64 in. lg, 15/32 in. w, 7/32 in. high, JAN-C-5, CM20D391J. (Same as C154)	DA109 network caps
J301	--- --- ---	CONNECTOR, RECEPTACLE: 1 contact, low-loss plastic, straight shape, 1-1/16 in. lg, 1/2 in. dia, BNC type UG-1094/U, locking type, 1 mtg hole 0.432 in. dia, SIG Corps Dwg SC-D-72305. (Same as J102)	Jack for dummy load
J302		Same as J301.	Jack for dummy load
L301	--- --- ---	CHOKE, RADIO FREQUENCY: 15 ma current rating, for use above 2.5 mc, 1/2 in. lg, 3/16 in. dia, NLIC Dwg 162-B-135.	Impedance matching network series inductor
R301	--- N16-R-049733-0811 ---	RESISTOR, FIXED, COMPOSITION: body style No. 3, MBCA Ref Dwg Group 2, 1500 ohms, ±5% tolerance, 1/2 w, characteristic F, 0.406 in. lg, 0.175 in. dia, insulated, JAN-R-11, RC20BF391J.	Load resistor

TABLE 8-2. TABLE OF REPLACEABLE PARTS

Reference Desig.	Stock Numbers Signal Corps Standard Navy Air Force	Name and Description	Locating Function
J401	--- --- ---	CONNECTOR, RECEPTACLE: 1 contact, low-loss plastic, straight shape, 1-1/16 in. lg, 1/2 in. dia, BNC type UG-1094/U, locking type, 1 mtg hole 0.432 in. dia, SIG Corps Dwg SC-D-72305. (Same as J102)	50 ohm coaxial fitting for impedance matching network
J402	--- --- ---	CONNECTOR, RECEPTACLE: 1 contact, low-loss plastic, straight type, over-all, 1-1/16 in. lg, 1/2 in. dia, 1 mtg hole 1/2 in. dia, threaded 1/2-32 in., NLIC Dwg 162-B-225.	Connects 70 ohm Navy receivers to network
R401	--- N16-R-049705-0431 3350-098000-2991	RESISTOR, FIXED, COMPOSITION: body style No. 3, MBCA Ref Dwg Group 2, 390 ohms, $\pm 5\%$ tolerance, 1/2 w, characteristic F, 0.406 in. lg, 0.175 in. dia, insulated, JAN-R-11, RC20BF331J.	Attenuator shunt resistor
R402	--- N16-R-049462-0431 3350-098000-2751	RESISTOR, FIXED, COMPOSITION: body style No. 3, MBCA Ref Dwg Group 2, 56 ohms, $\pm 5\%$ tolerance, 1/2 w, characteristic F, 0.406 in. lg, 0.175 in. dia, insulated, JAN-R-11, RC20BF560J.	Attenuator series resistor
R403	--- N16-R-49534-431 ---	RESISTOR, FIXED, COMPOSITION: body style No. 3, MBCA Ref Dwg Group 2, 82 ohms, $\pm 5\%$ tolerance, 1/2 w, characteristic F, 0.406 in. lg, 0.175 in. dia, insulated, JAN-R-11, RC20BF820J.	Attenuator shunt resistor



TABLE 8-2. TABLE OF REPLACEABLE PARTS

Reference Desig.	Stock Numbers Signal Corps Standard Navy Air Force	Name and Description	Locating Function
C501	--- --- ---	CAPACITOR, FIXED, PAPER DIELECTRIC: 1 section, 400 vdcw, 47,000 uuf, ±20% tolerance, case style No. 2, MBCA Ref Dwg Group 1, metal case, hermetically sealed, 13/16 in. lg, 0.4 in. dia, GUC XGS2268-20, NLIC Dwg 162-A-441. (Same as C118)	DC-blocking capacitor
E501	--- N17-C-802555-801 ---	CLIP, ELECTRICAL: alligator style No. 1, MBCA Ref Dwg Group 37, steel Cd plated, dim. 2 in. lg, 1/4 in. w, 3/8 in. high, not insulated, MUE Part No. 60.	Alligator clip on test lead
E502		Same as E501.	Alligator clips on test lead
J501	--- --- ---	CONNECTOR, RECEPTACLE: 1 contact, low-loss plastic, straight shape, 1-1/16 in. lg, 1/2 in. dia, BNC type UG-1094/U, locking type, 1 mtg hole 0.432 in. dia, SIG Corps Dwg SC-D-72305. (Same as J102)	Coaxial input jack for impedance matching network

TABLE 8-2. TABLE OF REPLACEABLE PARTS

Reference Desig.	Stock Numbers Signal Corps Standard Navy Air Force	Name and Description	Locating Function
C601	--- N16-C-049981-9970 3330-058750290	CAPACITOR, FIXED, PAPER DIELECTRIC: 1 section, 600 vdcw, 4 uf, +20% -10% tolerance; case style No. 34, MBCA Ref Dwg Group 1; metal case, hermetically sealed; 2-1/2 in. lg, 1-3/16 in. w, 3-7/8 in. high; JAN-C-25, CP70E1EF405V.	B+ filter capacitor
C602	--- N16-C-44289-8650 3330-31770439	CAPACITOR, FIXED, PAPER DIELECTRIC: 1 section, 600 vdcw, 50,000 uuf, ±20% tolerance; case style No. 2, MBCA Ref Dwg Group 1, metal case, hermetically sealed; 1-11/16 in. lg, 11/16 in. dia, JAN-C-25, CP26A1EF503M. (Same as C132)	L601 Filter capacitor
E601	--- N16-R-503580-213 ---	CLAMP, ELECTRICAL: stainless steel, fastened by stud type post; over-all dim., 13/16 in. dia, 3/16 in. high, designed to hold electron tube; TTE No. 3 Top Hat.	V602 Tube hold-down clamp
E602	--- N16-S-800651-175 ---	POST, SCREW, METAL: stainless steel, threaded No. 8-32 both ends, 3-1/4 in. lg w/2 nuts and 1 lockwasher; TTE 32.	V602 Tube hold-down clamp
J601	--- --- ---	CONNECTOR, RECEPTACLE: 10 contacts, type MFE insulation to Spec MIL-P-14, rectangular shape, 2-7/16 in. lg, 11/16 in. w, 1/2 in. high over-all excluding contacts; polarized, phosphor bronze contacts; non-locking; 2 mounting holes tapped No. 6-32, 2-3/32 in. c to c, NLIC Dwg 162-A-446.	Connection to power supply
L601	--- N16-R-029328-7975 ---	REACTOR, FIXED: inductance type, one coil, 28 henries, 75 ma DC, 400 ohms resistance, 3-1/8 in. lg, 3 in. w, 2-25/32 in. high, NLIC Dwg 162-C-020.	High voltage filter reactor
R601	--- N16-R-049536-0231 ---	RESISTOR, FIXED, COMPOSITION: body style No. 3, MBCA Ref Dwg Group 2, 82 ohms, ±10% tolerance, 1 w, characteristic E, 0.750 in. lg, 0.280 in. dia, insulated, JAN-R-11, RC30BF820K.	V601 Series plate resistor
R602		Same as R601.	V601 Series plate resistor
R603	--- N16-R-066103-7646 ---	RESISTOR, FIXED, WIRE WOUND: body style No. 20, MBCA Ref Dwg Group 2, 2000 ohms, ±5% tolerance, 8 w, 275°C, temp coefficient, 1 in. lg, 19/32 in. dia, cement coat, resistant to humidity, 11/64 in. w, 21/64 in. lg, JAN-R-26, RW31G202.	V602 Dropping resistor
R604	--- N16-R-049662-0231 ---	RESISTOR, FIXED, COMPOSITION: body style No. 3, MBCA Ref Dwg Group 2, 220 ohms, ±10% tolerance, 1 w, characteristic E, 0.750 in. lg, 0.280 in. dia, insulated, JAN-R-11, RC30BF221K.	V602 Dropping resistor
T601	--- --- ---	TRANSFORMER, POWER STEP-DOWN AND STEP-UP: open frame, 115 v ac, 50 to 1000 cps, single phase, No. 1 secondary 365 v, 70 ma, center tapped; No. 2 secondary 6.4 v, 4.25 amp impregnated; dim. MBCA Ref Dwg Group 12, 3-1/8 in. lg, 3 in. w, 2-11/16 in. high; NLIC Dwg 162-D-022.	Power transformer
V601	--- N16-T-056840-0050 ---	ELECTRON TUBE: glass envelope, rectifier, MIL-E-1B, JAN6X4W.	Rectifier
V602	--- N16-T-53030 ---	ELECTRON TUBE: glass envelope, voltage regulator, MIL-E-1B, JAN0A3.	Voltage regulator

TABLE 8-2. TABLE OF REPLACEABLE PARTS

Reference Desig.	Stock Numbers Signal Corps Standard Navy Air Force	Name and Description	Locating Function
XV601	R16-S-4396-500 N16-S-082603-6702 - - -	SOCKET, ELECTRON TUBE: section D, type E; molded plastic body, low-loss composition; 21/32 in. dia, hole rd shaped, plain; 25/32 in. lg, 0.800 in. dia; 2 mtg holes, provisions for mtg, electron tube shield are provided, bayonet type, electron tube retaining device not incl JAN-S-28A, TS102P01. (Same as XV101)	Holds and makes contact with tubes
XV602	- - - N16-S-063515-4151 - - -	SOCKET, ELECTRON TUBE: section B, type B; molded plastic body, low-loss composition; 1-1/8 in. dia, chassis hole; 2 mtg holes spaced c to c, 1-7/8 in. lg, 1-3/8 in. w, 1/2 in. high; provisions for mtg electron tube shield are provided, bayonet type, electron tube retaining device not incl, JAN-S-28A, TS101P01. (Same as XV103)	Holds and makes contact with tubes

TABLE 8-2. TABLE OF REPLACEABLE PARTS

Reference Desig.	Stock Numbers Signal Corps Standard Navy Air Force	Name and Description	Locating Function
P701	<p>--- N17-C-067990-2447 ---</p>	<p>ADAPTOR, CONNECTOR: 1 contact, low-loss plastic, straight, 1-7/16 in. lg, 3/4 in. dia, w/enclosing shell, copper base alloy, precious metal plated, one end locking, one end threaded, 3/4 in. OD coupling nut, 5/8 in. coupling nut thread, IPC UG-201A/U per SIG Corps Dwg SC-D-72309.</p>	<p>To adapt BNC output to Type "N" output</p>

TABLE 8-3. CROSS REFERENCE PARTS LIST

FEDERAL STOCK NO.	KEY SYMBOL	FEDERAL STOCK NO.	KEY SYMBOL	FEDERAL STOCK NO.	KEY SYMBOL
GM17-L-005195-0000	I101	N16-R-049661-0811	R157	N16-T-056177-0000	V103
GM3110-156-4278	O119	N16-R-049662-0231	R604	N16-T-056840-0050	V601
G41-W-2444-5	O104	N16-R-049705-0431	R401	N16-T-53030	V602
G41-W-2445-2	O103	N16-R-049723-0431	R105	N16-T-56185	V101
G41-W-2446-2	O128	N16-R-049733-0811	R301	N17-C-067990-2447	P701
N15-C-12200-575	W106	N16-R-049922-0811	R103	N17-C-71408-5333	P105
N16-C-011008-0500	C121	N16-R-050066-0811	R177	N17-C-802555-801	E501
N16-C-015433-4383	C107	N16-R-050201-0811	R173	N17-F-74267-5075	XF101
N16-C-015917-2572	C165	N16-R-05036-0811	R145	N17-J-039248-4418	J104
N16-C-015988-1600	C119	N16-R-050417-0811	R153	N17-M-029352-2959	M101
N16-C-015989-1215	C153	N16-R-050822-0811	R139	N17-S-065063-8605	S103
N16-C-016149-1215	C150	N16-R-050975-0811	R102	N17-S-072828-2805	S102
N16-C-016309-1215	C156	N16-R-072869-4209	R119	R16-NLIC-162B111	L101
N16-C-017973-1354	C123	N16-R-073112-5324	R147	R16-NLIC-162B116	L102
N16-C-018961-1550	C138	N16-R-073140-8033	R142	R16-NLIC-162C004	C101
N16-C-028553-1206	C160	N16-R-073161-4594	R131	R16-S-4396-500	XV101
N16-C-029265-3006	C301	N16-R-090868-2980	R158	R16JAN-CK63Y103Z	C103
N16-C-029370-7606	C166	N16-R-091291-4985	R143	R16JAN-CP70E1EF805V	C135
N16-C-029898-3606	C154	N16-R-49320-231	R134	R16JAN-RV3ATFD502A	R109
N16-C-032646-6808	C104	N16-R-49462-431	R402	3330-056750290	C601
N16-C-042762-5424	C139	N16-R-49534-431	R403	3330-0572-51184	C125
N16-C-045801-9324	C125	N16-R-49580-811	R106	3330-313050138	C158
N16-C-045807-8094	C142	N16-R-49625-811	R108	3330-313420185	C140
N16-C-049981-9970	C601	N16-R-49688-811	R113	3330-316777500	C142
N16-C-051501-9840	C135	N16-R-49705-431	R401	3330-317371-340	C135
N16-C-064062-6985	C146	N16-R-49769-811	R120	3330-31770439	C132
N16-C-071362-7077	L108	N16-R-49967-811	R107	3330-376013590	C301
N16-C-074438-8989	L107	N16-R-50012-811	R101	3330-376026200	C112
N16-C-076596-1365	L101	N16-R-50129-811	R175	3330-37603-4800	C117
N16-C-096783-1861	Y101	N16-R-50282-811	R111	3330-376150800	C104
N16-C-19140-9591	C103	N16-R-50372-811	R169	3350-098000-2271	R106
N16-C-29375-8076	C112	N16-R-503580-213	E601	3350-769500-2275	R109
N16-C-29608-2206	C157	N16-R-50480-811	R104	3350-098000-2791	R105
N16-C-30109-3806	C109	N16-R-50552-811	R115	3350-098000-2911	R120
N16-C-30114-4276	C117	N16-R-50633-811	R112	3350-098000-2991	R401
N16-C-31080-2214	C130	N16-R-50714-811	R138	3350-098000-3651	R101
N16-C-42767-6196	C133	N16-R-50759-811	R159	3350-098000-3971	R175
N16-C-44289-8652	C132	N16-R-72862-5322	R121	3350-098000-4391	R111
N16-C-63965-2800	C158	N16-R-72952-8301	R122	3350-098000-4711	R169
N16-C-64133-6581	C140	N16-S-034557-8351	E121	3350-098000-5291	R115
N16-C-71408-5333	P105	N16-S-034607-6039	E120	3350-098000-5451	R112
N16-C-73117-7602	L102	N16-S-062603-6702	XV101	3350-098000-5781	R138
N16-R-029328-7975	L601	N16-S-063515-4151	XV103	3350-098000-5891	R159
N16-R-049444-0431	R201	N16-S-800651-175	E602	3350-098000-6671	R102
N16-R-049462-0431	R402	N16-T-051760-0005	CR101		
N16-R-049536-0231	R601	N16-T-051769-0000	CR102		

TABLE 8-4. LIST OF MANUFACTURERS

ABBREVIATIONS	PREFIX	NAME	ADDRESS
ALII	CBUM	Allied Industries Inc	Louisville 10, Ky
ALN	CAYT	Allen Mfg, Company	Hartford 2, Conn
AUTT		Automatic and Precision Mfg, Co	Yonkers 5, N.Y.
BUI	CAVK	Burlington Instrument Co	Burlington, Iowa
BUS	CFA	Bussman Mfg, Company	St Louis, Mo
CPH	CTC	Chicago Telephone Supply, Co	Elkhart, Ind
DHM		Harry Davies Molding Co	Chicago 10, Ill
DMC	CAYS	Drake Mfg, Company	Chicago, Ill
ELCL		Elco Corporation	Philadelphia 24, Pa
ERC	CER	Erie Resistor Corporation	Erie, Pa
ETR		Electra Mfg, Company	Kansas City, Mo
GLEC	CG	General Electric Co, Lamp Dept	Newton Upper Falls 64, Mass
GUC	CGF	Gudeman Co	Chicago 10, Ill
HOV		Hoover Ball and Bearing, Co	Ann Arbor, Mich
IPC	CARO	Industrial Products Co	Danbury, Conn
MUE	CBIT	Mueller Electric Co	Cleveland 14, Ohio
NF	CNZ	National Fabricated Products, Inc	Chicago, Ill
NH		Norma-Hoffmann Bearings Corp	Stamford, Conn
NI		Nice Ball Bearing Co	Philadelphia, Pa
NLIC		New London Instrument Co	New London, Conn
REHO		Reeves-Hoffman Corp	Carlisle, Pa
SPR	CSF	Sprague Electric Co	North Adams, Mass
TTE	CACA	Times Facsimile Corp	New York 19, N.Y.
UNRL		Underwriters Laboratories, Inc	New York, N.Y.
WAEQ		Whitso, Inc	Schiller Park, Ill

**RESISTOR COLOR CODES**

RMA COLOR CODE FOR  
FUSED COMPOSITION RESISTORS

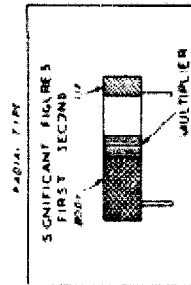
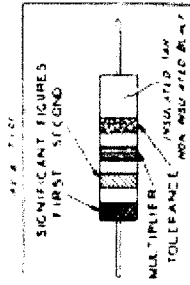

JAN COLOR CODE FOR  
FUSED COMPOSITION RESISTORS

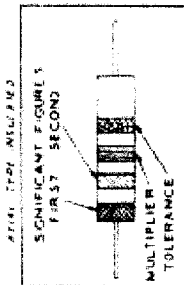

JAN COLOR CODE FOR  
FUSED COMPOSITION RESISTORS

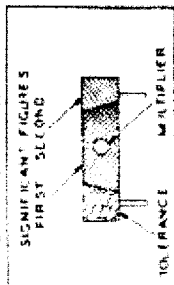

**CAPACITOR COLOR CODES**

RMA 7-007 COLOR CODE FOR MICA DIELECTRIC CAPACITORS

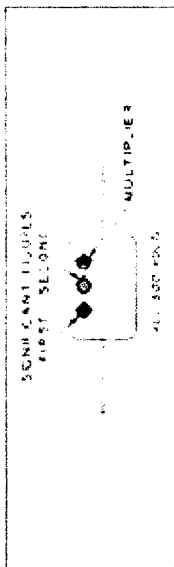

JAN 2-007 COLOR CODE FOR MICA DIELECTRIC CAPACITORS

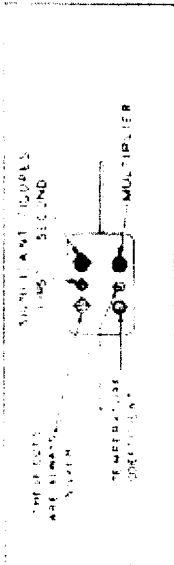

RMA 8-007 COLOR CODE FOR MICA DIELECTRIC CAPACITORS

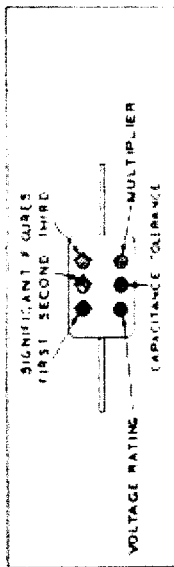

JAN 2-007 COLOR CODE FOR MICA DIELECTRIC CAPACITORS

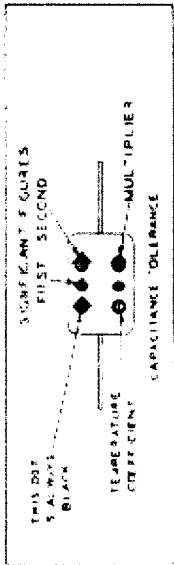

RMA COLOR CODE FOR TUBULAR  
CERAMIC-DIELECTRIC CAPACITORS

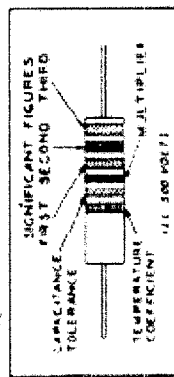

JAN COLOR CODE FOR TUBULAR  
CERAMIC-DIELECTRIC CAPACITORS

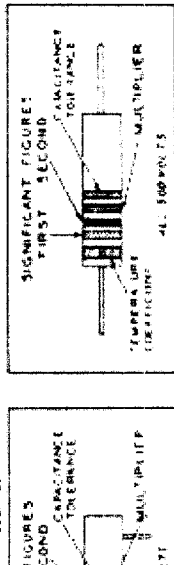

RMA RADIO MANUFACTURERS ASSOCIATION  
JAN JOINT ARMY-NAVY

RESISTORS		CAPACITORS	
TOLERANCE	MULTIPLIER	SIGNIFICANT FIGURE	COLOR
1	0	0	BROWN
10	10	10	RED
100	100	100	ORANGE
500	500	500	YELLOW
10000	10000	10000	GREEN
100000	100000	100000	BLUE
1000000	1000000	1000000	PURPLE
10000000	10000000	10000000	GRAY
100000000	100000000	100000000	WHITE
5	0.1	0.1	YELLOW
10	0.1	0.1	YELLOW
20	0.1	0.1	NO COLOR

RMA MICA AND CERAMIC DIELECTRIC	JAN CERAMIC DIELECTRIC	VOLTAGE RATING	TEMPERATURE COEFFICIENT
COLOR	MULTIPLIER	A	B
BROWN	10	100	100
RED	100	200	200
ORANGE	1000	300	300
YELLOW	10000	400	400
GREEN	100000	500	500
BLUE	1000000	600	600
PURPLE	10000000	700	700
GRAY	100000000	800	800
WHITE	1000000000	900	900
YELLOW	0.1	1000	1000
YELLOW	0.1	2000	2000
NO COLOR	0.1	500	500

TABLE 8-5. APPLICABLE COLOR CODES AND MISCELLANEOUS DATA

## INDEX

SUBJECT	FIGURE OR TABLE	SECTION	PARAGRAPH	PAGE
<b>A</b>				
Amplifier—				
buffer		2	3	2-4
calibrating mixer and modulated, RF		2	9	2-12
modulated, RF		2	4	2-4
AN/URM-25F RF Signal Generator Set see "RF Signal Generator Set AN/URM-25F"				
<b>C</b>				
Cable Assembly CG-409 A/U see "Cord CG-409 A/U"				
Calibration—				
attenuator, RF	4-3	4		4-4
crystal		4	5	4-2
crystal oscillator		7	21	7-13
frequency—				
data of	7-1	7		7-14
readjustment of		7	15	7-7
meter, percent modulation		7	19	7-10
metering, RF		7	18	7-9
oscillator, procedure for RF		7	16	7-8
CG-409 A/U Cord see "Cord CG-409 A/U"				
Charts—				
frequency calibration data	7-1	7		7-14
rated tube characteristics	7-7	7		7-22
resistance measurements	7-6	7		7-21
routine check		6	1	6-1
trouble—	5-1	5		5-1
localization	7-3	7		7-16
specific, test for	7-4	7		7-17
symptom	7-2	7		7-15
voltages and currents, tube operating	7-5	7		7-20
Circuits—				
description, general		2	1	2-0
power		4	2	4-0
Cord CG-409 A/U—				
coupling to receiver under test		4	10	4-5
description		2	16	2-18
terminating		4	9	4-4
methods of	4-4 4-5	4 4		4-5 4-7
CU-406/URM-25F Impedance Matching Network see "Impedance Matching Network CU-406/ URM-25F"				
CU-408/URM-25F Impedance Matching Network see "Impedance Matching Network CU-408/ URM-25F"				
CW-346/URM-25F Signal Generator Cover see "Signal Generator Cover CW-346/URM-25F"				
CX-2919/U Test Lead see "Test Lead CX-2919/U"				



SUBJECT	FIGURE OR TABLE	SECTION	PARAGRAPH	PAGE
<b>D</b>				
DA-109/URM-25F Electrical Dummy Load see "Electrical Dummy Load DA-109/URM-25F"				
Data, reference .....		1	2	1-1
<b>E</b>				
Electrical Dummy Load DA-109/URM-25F, use of .....		4	11	4-5
Electron tube complement .....		1	4	1-2
	1-3	1	.....	1-2
Equipments—				
complete list of units in .....		1	1d	1-1
similarities between .....		1	5	1-2
supplied .....	1-1	1	.....	1-2
<b>F</b>				
Frequency—				
calibration, data of .....	7-1	7	.....	7-14
carrier, setting of .....		4	3	4-0
interpolation procedure .....	4-2	4	.....	4-2
ranges, band switch .....	2-1	2	.....	2-18
<b>I</b>				
Impedance Matching Network CU-406/URM-25F, description .....		2	12	2-17
Impedance Matching Network CU-408/URM-25F, description .....		2	13	2-17
Interpolation, procedure for frequency .....	4-2	4	.....	4-2
<b>L</b>				
Lubrication data .....		6	2	6-1
	6-1	6	.....	6-1
<b>M</b>				
Maintenance—				
corrective—				
calibration—				
crystal oscillator .....		7	21	7-13
frequency—				
data of .....	7-1	7	.....	7-14
readjustment of .....		7	15	7-7
metering, RF .....		7	18	7-9
oscillator, procedure for RF .....		7	16	7-8
disassembly of step attenuator .....		7	10	7-3
localization, theory of .....		7	1	7-1
removal of—				
bridge assembly .....		7	17	7-9
oscillator—				
coil turret .....		7	11	7-6
transformer assembly .....		7	12	7-6
parts .....		7	9	7-2
shield assembly, RF .....		7	8	7-2
signal generator from case .....		7	7	7-2
tuning capacitor .....		7	13	7-7
replacement of—				
dial scale lamp .....		7	22	7-13
oscillator circuit components, RF .....		7	14	7-7

SUBJECT	FIGURE OR TABLE	SECTION	PARAGRAPH	PAGE
parts .....		7	9	7-2
resistance measurements .....		7	5	7-1
	7-6	7	.....	7-21
tests—				
specific trouble chart .....	7-4	7	.....	7-17
step attenuator, RF .....		7	20	7-10
trouble localization chart .....	7-3	7	.....	7-16
trouble shooting—				
symptom chart .....	7-2	7	.....	7-15
system .....		7	3	7-1
test equipment for .....		7	2	7-1
tube characteristics, rated .....	7-7	7	.....	7-22
units, interior and exterior views of .....		7	6	7-1
voltages and currents, tube operating .....		7	4	7-1
	7-5	7	.....	7-20
operator's—				
fuse—				
failure, symptoms of .....	5-2	5	.....	5-2
replacement .....		5	3	5-1
general .....		5	1	5-1
indicator lamp .....		5	4	5-1
routine check chart .....		5	2	5-1
	5-1	5	.....	5-1
preventive—				
lubrication data .....		6	2	6-1
	6-1	6	.....	6-1
routine check chart .....		6	1	6-1
Metering, RF and modulation .....		2	10	2-12
Modulation—				
external .....		4	8	4-4
internal .....		4	7a	4-4
types of .....		1	2j	1-1
Modulator .....		2	7	2-8

## N

## Networks, Impedance Matching—

CU-406/URM-25F .....		2	12	2-17
CU-408/URM-25F .....		2	13	2-17

## O

Operating procedure, simplified .....			Introduction .....	i
Oscillator—				
audio .....		2	6	2-8
buffer .....		2	3	2-4
coil turret, removal of .....		7	11	7-6
crystal .....		2	8	2-11
RF .....		2	2	2-3
transformer—				
assemblies, component values of .....	2-2	2	.....	2-18
assembly removal .....		7	12	7-6

SUBJECT	FIGURE OR TABLE	SECTION	PARAGRAPH	PAGE
Output—				
audio (400 or 10000 cycles) .....		4	7b	4-4
crystal-controlled .....		4	4	4-2
RF—				
adjusting—				
adjustments .....		4	6b	4-3
preliminary settings .....		4	6a	4-3
high .....		4	10b	4-5

## P

Parts lists .....		8		8-1
Power circuit .....		4	2	4-0
Power Supply PP-1322/URM-25F, description .....		2	11	2-15
PP-1322/URM-25F Power Supply see "Power Supply PP-1322/URM-25F"				

## R

Receiver tests—				
alignment .....		4	12b(6)	4-7
above 50 megacycles .....		4	12b(7)	4-8
audio response .....		4	12b(4)	4-7
general .....		4	12b(1)	4-6
measuring gain per stage .....		4	12b(5)	4-7
selectivity .....		4	12b(3)	4-6
sensitivity .....		4	12b(2)	4-6
Resistance measurements .....		7	5	7-1
	7-6	7		7-21
RF Signal Generator Set AN/URM-25F—				
adjustments .....		3	3	3-1
basic differences in .....	1-4	1		1-3
circuits, description of .....		2	1	2-0
description .....		1	3	1-2
equipment consists of .....		1	1d	1-1
	1-1	1		1-2
installation .....		3	2	3-1
operating procedure, simplified .....		Introduction		i
operation, general .....		4	1	4-0
reference data .....		1	2	1-1
unpacking .....		3	1	3-1
using—				
modulated operation .....	12c	4	12c	4-8
operating controls .....		4	12a	4-6
receiver—				
output .....		4	12d	4-8
overall sensitivity .....		4	12e	4-8
tests .....		4	12b	4-6
standard levels .....		4	12f	4-8
voltmeter as output meter .....		4	12g	4-8

## S

SG-103/URM-25F Signal Generator see "Signal Generator SG-103/URM-25F"				
Shipping data .....	1-2	1		1-2
Signal Generator SG-103/URM-25F .....		1	1d	1-1
Signal Generator Cover CW-346/URM-25F .....		1	1d	1-1

SUBJECT	FIGURE OR TABLE	SECTION	PARAGRAPH	PAGE
<b>T</b>				
Test Lead CX-2919/U, description .....		2	15	2-17
Tests—				
specific trouble chart .....	7-4	7		7-17
step attenuator, RF .....		7	20	7-10
Trouble—				
localization chart .....	7-3	7		7-16
shooting—				
system .....		7	3	7-1
test equipment for .....		7	2	7-1
specific test chart .....	7-4	7		7-17
symptom chart .....	7-2	7		7-15
Tube characteristics, rated .....	7-7	7		7-22
<b>U</b>				
Units comprising RF Signal Generator AN/URM-25F .....		1	1d	1-1
<b>V</b>				
Voltage—				
output, RF .....		1	2k	1-1
adjusting—		2	5	2-6
adjustments .....		4	6b	4-3
preliminary settings .....		4	6a	4-3
Voltages and currents, tube operating .....	7-5	7		7-20