

FM-Spulensatz 7434-051 ZF=10,7 MHz
 AM-Spulensatz 7417-118 ZF=460 kHz
 FM-COIL-SET 7434-051 F=10,7 Mc
 AM-COIL-SET 7417-118 F=460 kc
 BLOC-BOBINAGE FM-7434-051 F1 10,7 Mc
 BLOC-BOBINAGE AM-7417-118 F1 460 kc

Spannungen mit Grundig-Röhrenvoltmeter
 Ströme mit Multivari 5 bei 220V-Netzspannung
 ohne Signal gemessen

VOLTAGE MEASURED WITH GRUNDIG VTVM CURRENTS
 WITH MULTIVARI 5 AT 220V A.C. LINE VOLTAGE
 MEASURED WITHOUT SIGNAL

TENSION MESURÉE AVEC GRUNDIG VOLTMÈTRE
 ÉLECTRONIQUE, LES COURANTS AVEC MULTIVARI 5
 TENSION ALTERNATIF LA TENSION DE RESEAU MESURÉE
 SANS SIGNAL

Wellenbereiche
 WAVE BANDS
 GAMMES D'ONDES

UKW/FM	87,5	-	108 MHz / Mc
KW/SW/OC	5,4	-	16,2 MHz / Mc
MW/PO	510	-	1620 kHz / kc
LW/OO	145	-	350 kHz / kc

RTV 350 a

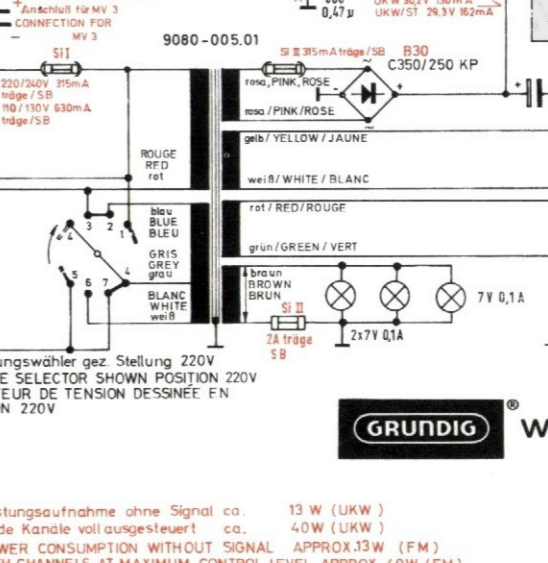
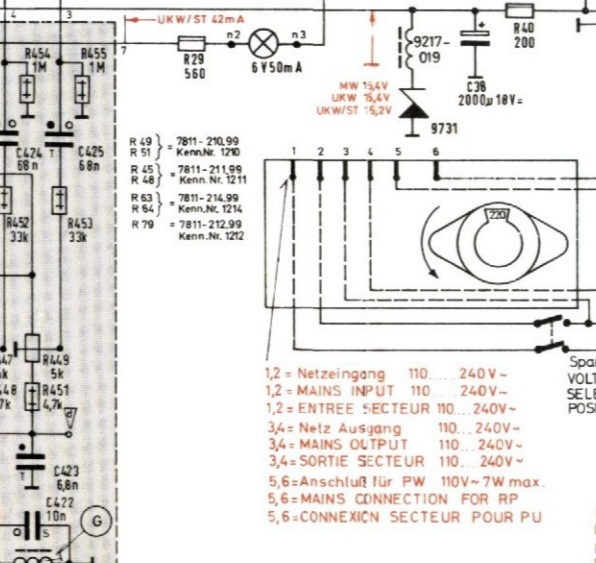
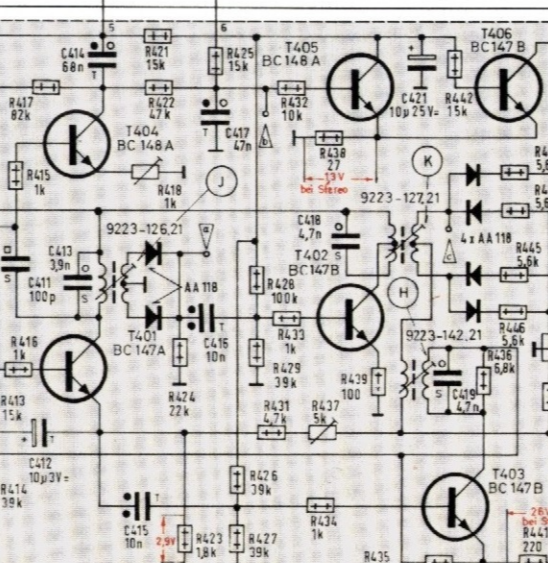
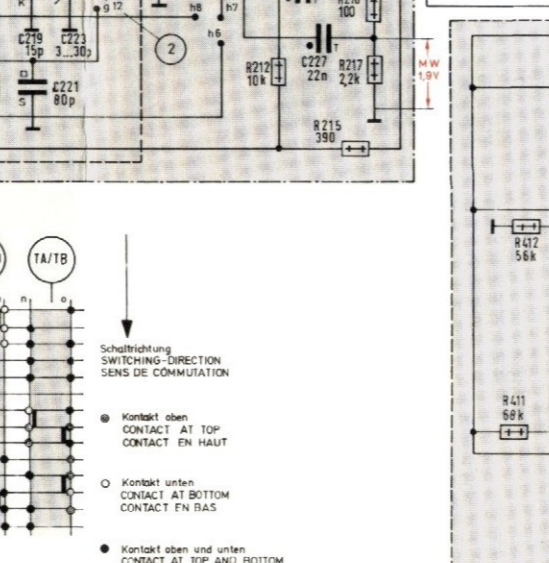
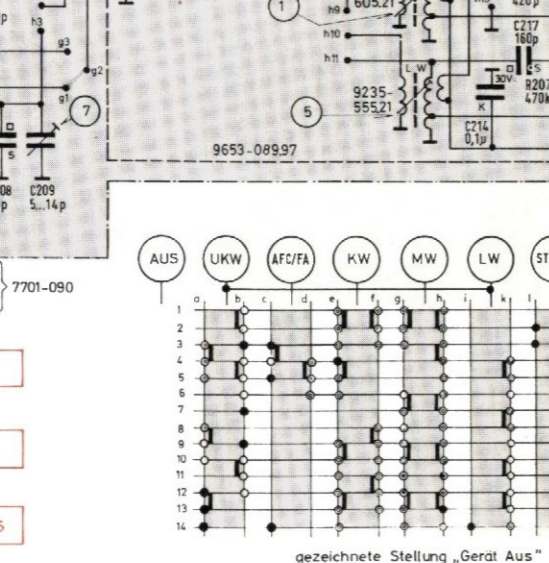
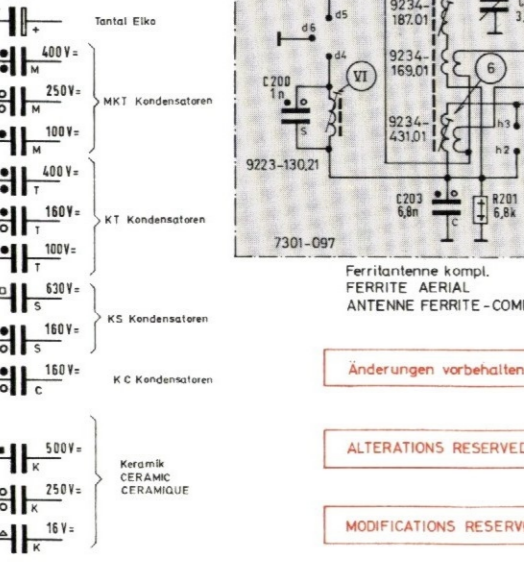
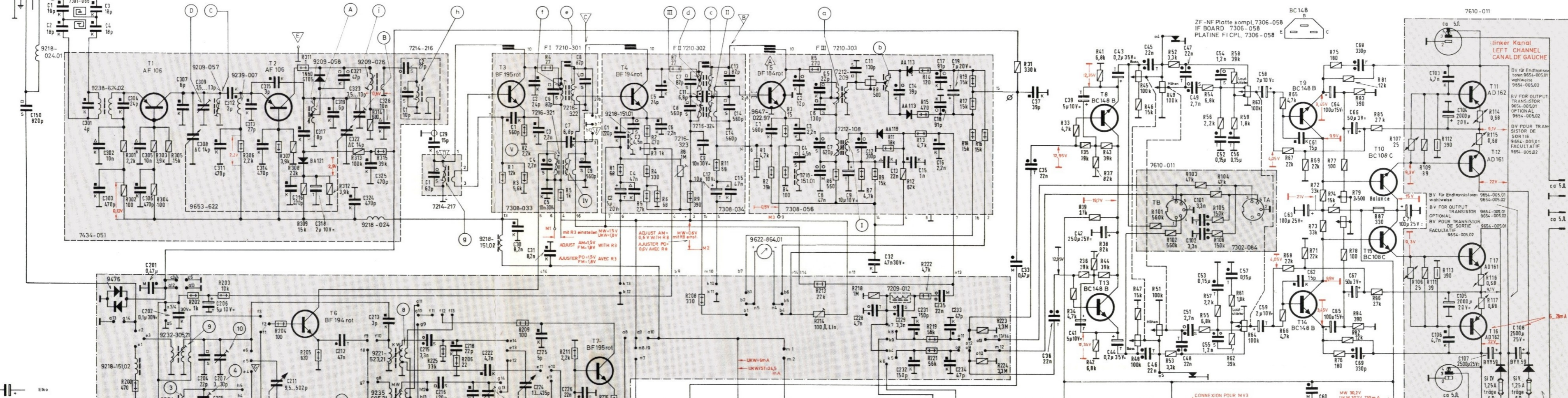
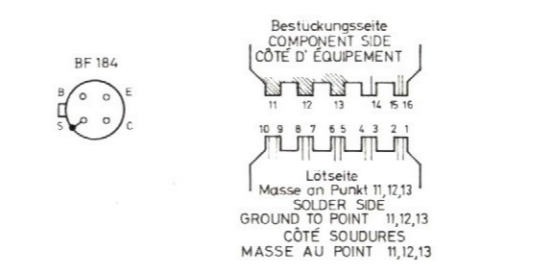
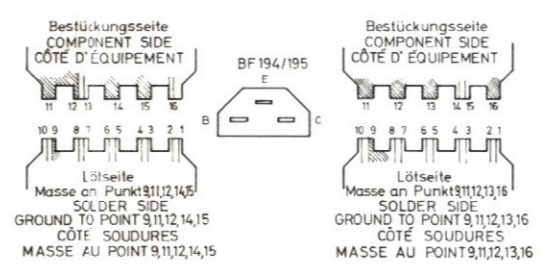
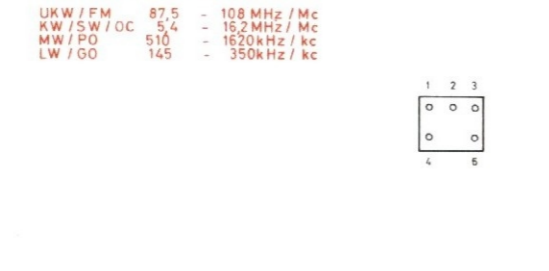
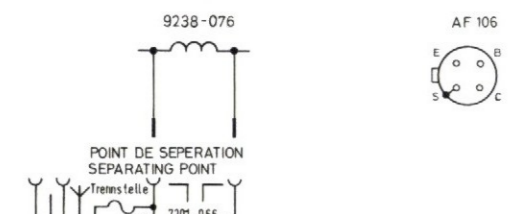

20564 / 2

C:	1, 2, 3, 4, 150, 301, 302, 303, 304, 305, 306, 307, 308, 309, 310, 311, 312, 313, 314, 315, 316, 317, 318, 319, 320, 321, 322, 323, 324, 325, 326, 327, 328, 329, 330, 331, 332, 333, 334, 335, 336, 337, 338, 339, 340, 341, 342, 343, 344, 345, 346, 347, 348, 349, 350, 351, 352, 353, 354, 355, 356, 357, 358, 359, 360, 361, 362, 363, 364, 365, 366, 367, 368, 369, 370, 371, 372, 373, 374, 375, 376, 377, 378, 379, 380, 381, 382, 383, 384, 385, 386, 387, 388, 389, 390, 391, 392, 393, 394, 395, 396, 397, 398, 399, 400, 401, 402, 403, 404, 405, 406, 407, 408, 409, 410, 411, 412, 413, 414, 415, 416, 417, 418, 419, 420, 421, 422, 423, 424, 425, 426, 427, 428, 429, 430, 431, 432, 433, 434, 435, 436, 437, 438, 439, 440, 441, 442, 443, 444, 445, 446, 447, 448, 449, 450, 451, 452, 453, 454, 455, 456, 457, 458, 459, 460, 461, 462, 463, 464, 465, 466, 467, 468, 469, 470, 471, 472, 473, 474, 475, 476, 477, 478, 479, 480, 481, 482, 483, 484, 485, 486, 487, 488, 489, 490, 491, 492, 493, 494, 495, 496, 497, 498, 499, 500, 501, 502, 503, 504, 505, 506, 507, 508, 509, 510, 511, 512, 513, 514, 515, 516, 517, 518, 519, 520, 521, 522, 523, 524, 525, 526, 527, 528, 529, 530, 531, 532, 533, 534, 535, 536, 537, 538, 539, 540, 541, 542, 543, 544, 545, 546, 547, 548, 549, 550, 551, 552, 553, 554, 555, 556, 557, 558, 559, 560, 561, 562, 563, 564, 565, 566, 567, 568, 569, 570, 571, 572, 573, 574, 575, 576, 577, 578, 579, 580, 581, 582, 583, 584, 585, 586, 587, 588, 589, 590, 591, 592, 593, 594, 595, 596, 597, 598, 599, 600, 601, 602, 603, 604, 605, 606, 607, 608, 609, 610, 611, 612, 613, 614, 615, 616, 617, 618, 619, 620, 621, 622, 623, 624, 625, 626, 627, 628, 629, 630, 631, 632, 633, 634, 635, 636, 637, 638, 639, 640, 641, 642, 643, 644, 645, 646, 647, 648, 649, 650, 651, 652, 653, 654, 655, 656, 657, 658, 659, 660, 661, 662, 663, 664, 665, 666, 667, 668, 669, 670, 671, 672, 673, 674, 675, 676, 677, 678, 679, 680, 681, 682, 683, 684, 685, 686, 687, 688, 689, 690, 691, 692, 693, 694, 695, 696, 697, 698, 699, 700, 701, 702, 703, 704, 705, 706, 707, 708, 709, 710, 711, 712, 713, 714, 715, 716, 717, 718, 719, 720, 721, 722, 723, 724, 725, 726, 727, 728, 729, 730, 731, 732, 733, 734, 735, 736, 737, 738, 739, 740, 741, 742, 743, 744, 745, 746, 747, 748, 749, 750, 751, 752, 753, 754, 755, 756, 757, 758, 759, 760, 761, 762, 763, 764, 765, 766, 767, 768, 769, 770, 771, 772, 773, 774, 775, 776, 777, 778, 779, 780, 781, 782, 783, 784, 785, 786, 787, 788, 789, 790, 791, 792, 793, 794, 795, 796, 797, 798, 799, 800, 801, 802, 803, 804, 805, 806, 807, 808, 809, 810, 811, 812, 813, 814, 815, 816, 817, 818, 819, 820, 821, 822, 823, 824, 825, 826, 827, 828, 829, 830, 831, 832, 833, 834, 835, 836, 837, 838, 839, 840, 841, 842, 843, 844, 845, 846, 847, 848, 849, 850, 851, 852, 853, 854, 855, 856, 857, 858, 859, 860, 861, 862, 863, 864, 865, 866, 867, 868, 869, 870, 871, 872, 873, 874, 875, 876, 877, 878, 879, 880, 881, 882, 883, 884, 885, 886, 887, 888, 889, 890, 891, 892, 893, 894, 895, 896, 897, 898, 899, 900, 901, 902, 903, 904, 905, 906, 907, 908, 909, 910, 911, 912, 913, 914, 915, 916, 917, 918, 919, 920, 921, 922, 923, 924, 925, 926, 927, 928, 929, 930, 931, 932, 933, 934, 935, 936, 937, 938, 939, 940, 941, 942, 943, 944, 945, 946, 947, 948, 949, 950, 951, 952, 953, 954, 955, 956, 957, 958, 959, 960, 961, 962, 963, 964, 965, 966, 967, 968, 969, 970, 971, 972, 973, 974, 975, 976, 977, 978, 979, 980, 981, 982, 983, 984, 985, 986, 987, 988, 989, 990, 991, 992, 993, 994, 995, 996, 997, 998, 999, 1000
----	--------------------------------------------------------------------------------------------------------------------------------------------------------------------------------------------------------------------------------------------------------------------------------------------------------------------------------------------------------------------------------------------------------------------------------------------------------------------------------------------------------------------------------------------------------------------------------------------------------------------------------------------------------------------------------------------------------------------------------------------------------------------------------------------------------------------------------------------------------------------------------------------------------------------------------------------------------------------------------------------------------------------------------------------------------------------------------------------------------------------------------------------------------------------------------------------------------------------------------------------------------------------------------------------------------------------------------------------------------------------------------------------------------------------------------------------------------------------------------------------------------------------------------------------------------------------------------------------------------------------------------------------------------------------------------------------------------------------------------------------------------------------------------------------------------------------------------------------------------------------------------------------------------------------------------------------------------------------------------------------------------------------------------------------------------------------------------------------------------------------------------------------------------------------------------------------------------------------------------------------------------------------------------------------------------------------------------------------------------------------------------------------------------------------------------------------------------------------------------------------------------------------------------------------------------------------------------------------------------------------------------------------------------------------------------------------------------------------------------------------------------------------------------------------------------------------------------------------------------------------------------------------------------------------------------------------------------------------------------------------------------------------------------------------------------------------------------------------------------------------------------------------------------------------------------------------------------------------------------------------------------------------------------------------------------------------------------------------------------------------------------------------------------------------------------------------------------------------------------------------------------------------------------------------------------------------------------------------------------------------------------------------------------------

7214-217	C: 1, 2, 3, 4, 5, 6, 7, 8, 9, 10, 11, 12, 13, 14, 15, 16, 17, 18, 19, 20, 21, 22, 23, 24, 25, 26, 27, 28, 29, 30, 31, 32, 33, 34, 35, 36, 37, 38, 39, 40, 41, 42, 43, 44, 45, 46, 47, 48, 49, 50, 51, 52, 53, 54, 55, 56, 57, 58, 59, 60, 61, 62, 63, 64, 65, 66, 67, 68, 69, 70, 71, 72, 73, 74, 75, 76, 77, 78, 79, 80, 81, 82, 83, 84, 85, 86, 87, 88, 89, 90, 91, 92, 93, 94, 95, 96, 97, 98, 99, 100
----------	-----------------------------------------------------------------------------------------------------------------------------------------------------------------------------------------------------------------------------------------------------------------------------------------------------------------------------------------------------------------------------------------------------------

ZF I 7210-301	C: 1, 2, 3, 4, 5, 6, 7, 8, 9, 10, 11, 12, 13, 14, 15, 16, 17, 18, 19, 20, 21, 22, 23, 24, 25, 26, 27, 28, 29, 30, 31, 32, 33, 34, 35, 36, 37, 38, 39, 40, 41, 42, 43, 44, 45, 46, 47, 48, 49, 50, 51, 52, 53, 54, 55, 56, 57, 58, 59, 60, 61, 62, 63, 64, 65, 66, 67, 68, 69, 70, 71, 72, 73, 74, 75, 76, 77, 78, 79, 80, 81, 82, 83, 84, 85, 86, 87, 88, 89, 90, 91, 92, 93, 94, 95, 96, 97, 98, 99, 100
---------------	-----------------------------------------------------------------------------------------------------------------------------------------------------------------------------------------------------------------------------------------------------------------------------------------------------------------------------------------------------------------------------------------------------------

ZF II 7210-302	C: 1, 2, 3, 4, 5, 6, 7, 8, 9, 10, 11, 12, 13, 14, 15, 16, 17, 18, 19, 20, 21, 22, 23, 24, 25, 26, 27, 28, 29, 30, 31, 32, 33, 34, 35, 36, 37, 38, 39, 40, 41, 42, 43, 44, 45, 46, 47, 48, 49, 50, 51, 52, 53, 54, 55, 56, 57, 58, 59, 60, 61, 62, 63, 64, 65, 66, 67, 68, 69, 70, 71, 72, 73, 74, 75, 76, 77, 78, 79, 80, 81, 82, 83, 84, 85, 86, 87, 88, 89, 90, 91, 92, 93, 94, 95, 96, 97, 98, 99, 100
----------------	-----------------------------------------------------------------------------------------------------------------------------------------------------------------------------------------------------------------------------------------------------------------------------------------------------------------------------------------------------------------------------------------------------------

ZF III 7210-310	C: 1, 2, 3, 4, 5, 6, 7, 8, 9, 10, 11, 12, 13, 14, 15, 16, 17, 18, 19, 20, 21, 22, 23, 24, 25, 26, 27, 28, 29, 30, 31, 32, 33, 34, 35, 36, 37, 38, 39, 40, 41, 42, 43, 44, 45, 46, 47, 48, 49, 50, 51, 52, 53, 54, 55, 56, 57, 58, 59, 60, 61, 62, 63, 64, 65, 66, 67, 68, 69, 70, 71, 72, 73, 74, 75, 76, 77, 78, 79, 80, 81, 82, 83, 84, 85, 86, 87, 88, 89, 90, 91, 92, 93, 94, 95, 96, 97, 98, 99, 100
-----------------	-----------------------------------------------------------------------------------------------------------------------------------------------------------------------------------------------------------------------------------------------------------------------------------------------------------------------------------------------------------------------------------------------------------

Leistungsaufnahme ohne Signal ca. 13 W (UKW)
 beide Kanäle vollausgesteuert ca. 40 W (UKW)
 POWER CONSUMPTION WITHOUT SIGNAL APPROX. 13 W (FM)
 BOTH CHANNELS AT MAXIMUM CONTROL LEVEL APPROX. 40 W (FM)
 PUISSANCE ABSORBÉE SANS SIGNAL APPROX. 13 W (FM)
 LES DEUX CANAUX À LA MODULATION MAXIMUM APPROX. 40 W (FM)

GRUNDIG WERKE GMBH FÜRTH (BAY.)

Grundchassis CS 350 a

(19-8060-1001)

RTV 350 a

(11-1551-1101)

Remplacement des curseurs de contact aux fins de réparation

Le remplacement des curseurs de contact est très facile à réaliser. Pour cela, il faut démonter le châssis et retirer le cadran (fig. 1).

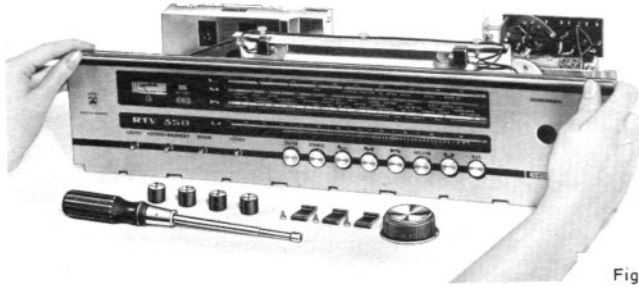

Fig. 1

À cause du bain de soudure, les petites ouvertures mesurant 4,5 x 10 mm dans la plaquette de circuits imprimés sont recouvertes par des bandes adhésives qu'il faut enlever.

On retire alors le petit ressort à pression qui se trouve au-dessous du châssis et qui correspond à chaque curseur. Il est recommandé d'utiliser dans ce but des brucelles, avec lesquelles on peut réaliser également dans de bonnes conditions la mise en place de ces ressorts. (Fig. 2)

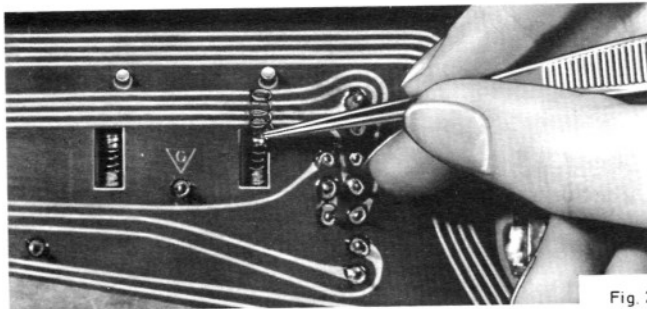

Fig. 2

On sépare alors du curseur considéré le bouton-poussoir correspondant, en le déplaçant d'un mouvement de traction pas trop doux vers le bas et vers l'avant (Fig. 3).



Fig. 3

Direction d'enlèvement du bouton-poussoir.

Une fois cela fait, on n'a plus qu'à exercer une traction sur le curseur en matière plastique, auquel est accroché le bouton, pour que le levier fourchu en matière plastique servant à actionner le poussoir puisse se rabattre vers l'avant. La fig. 4 (dans le cas des curseurs mono/stéréo ainsi que AFC/PA, il faut retirer également le volet à cran d'arrêt) une fois cela fait, il n'y a plus qu'à retirer le curseur de son logement. Il faut cependant faire attention, lors de l'opération, que les minuscules ressorts de contact ne sautent pas de leur cône de fixation.

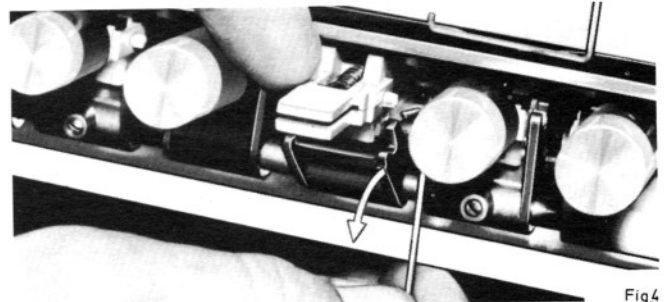

Fig. 4

On procède en sens inverse lors du montage. Au cours de cette opération il faut veiller, lors de l'introduction du curseur, à ne pas déformer les ressorts de contact. Dans ce but, on fait tourner tous les ressorts de contact sur leur tourillon de manière qu'ils agissent par rapport à la direction d'introduction des surfaces de contact à la manière d'un biseau de mise en place. Les ressorts de contact glissent alors bien en direction de l'intérieur de la cavité (fig. 5).

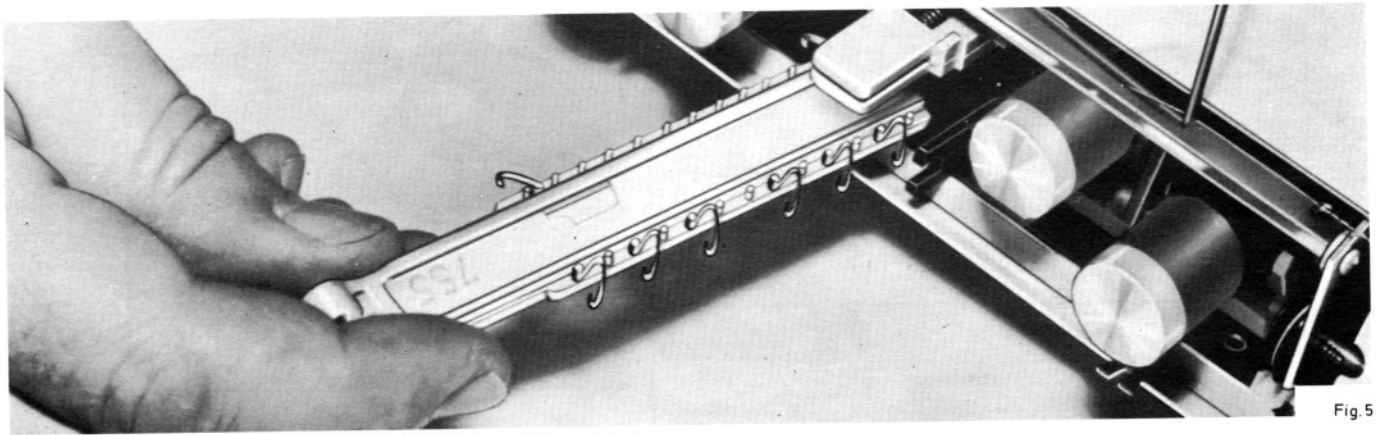
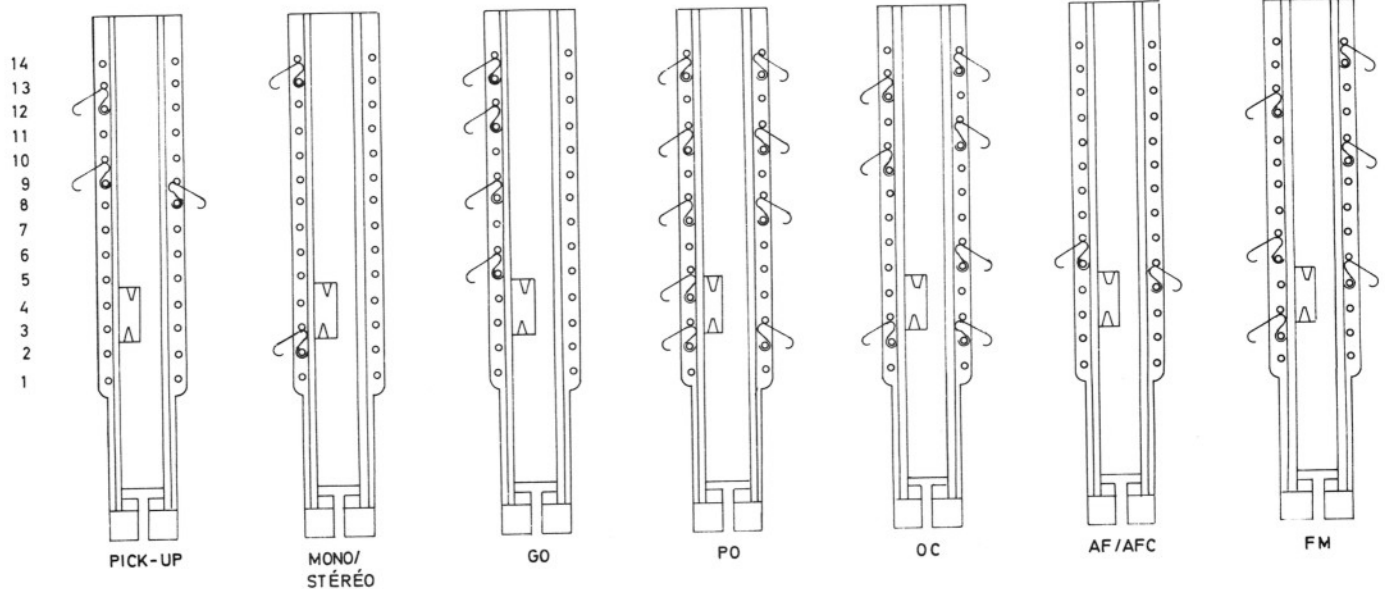
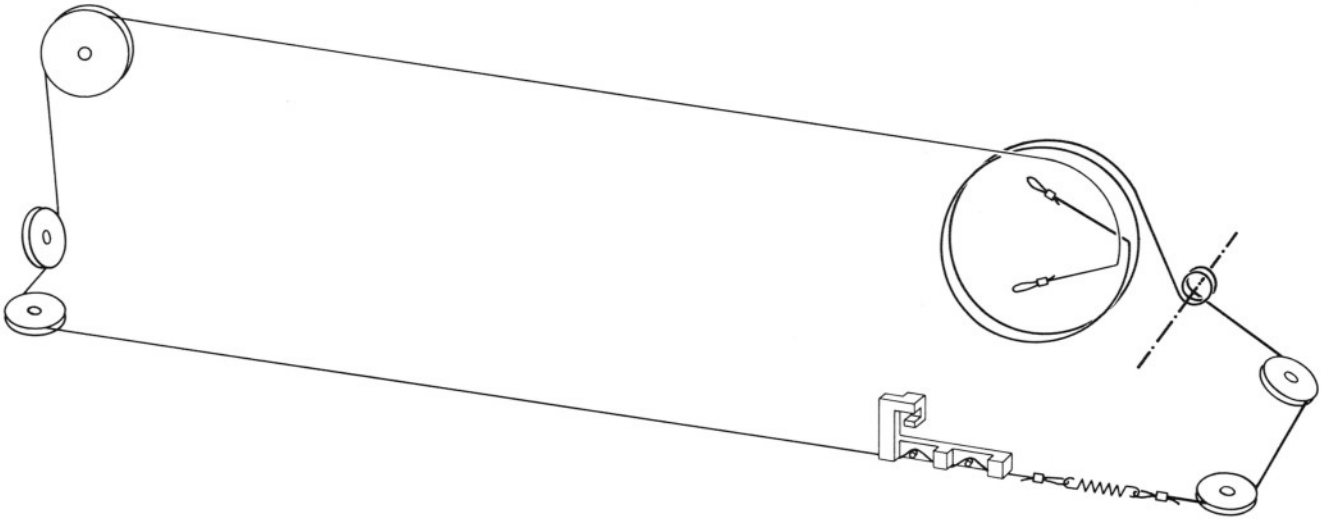

Fig. 5

PLAN DE MONTAGE DES COMPOSANTS SUR LES CURSEURS



Commande d'entraînement FM, vue du côté du cadran
 câble en fibres textiles, longueur 525 mm environ
 câble en acier, longueur 755 mm environ.



Commande d'entraînement AM, vue du côté du cadran
 câble en fibres textiles, longueur environ 590 mm
 câble en acier, longueur environ 645 mm

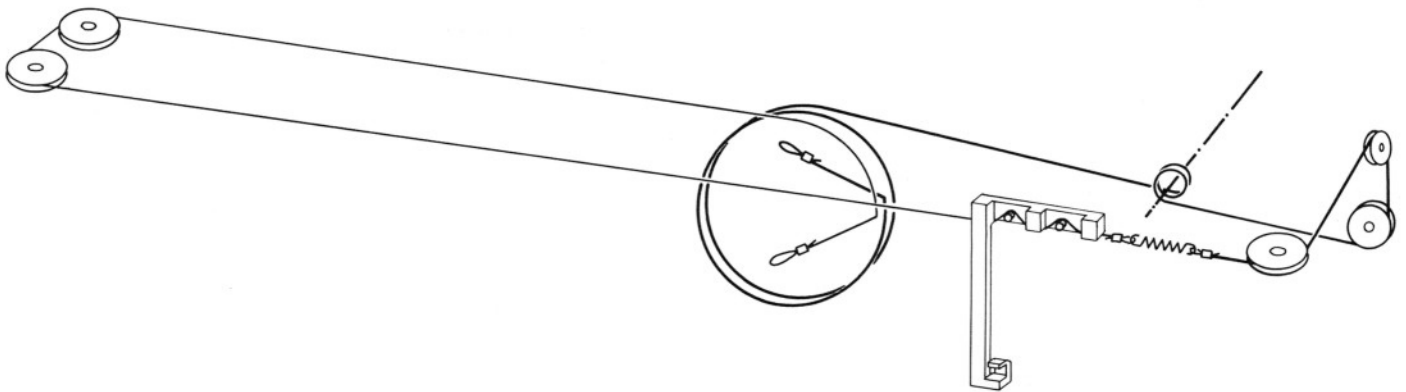

Remarque

Si le transfo d'alimentation secteur doit être remplacé aux fins de réparation, il faut dessouder toutes les connexions. Il faut retirer sur la face intérieure gauche une vis parker. On retire à droite les deux vis M4 qui maintiennent fermement ensemble les feuilles de tôle du transfo, car les vis de fixation des équerres de fixation ne sont pas accessibles (voir le croquis). Si l'on retire encore la plaque du sélecteur de tension, on peut sortir le transformateur d'alimentation sans difficulté de bas en haut, cependant que les deux équerres de fixation droites restent sur l'appareil.

CORRECTIONS

Concernent : Les instructions pour les réparations CS 350, RTV 350, HF 350.

Sur le schéma des instructions concernant les réparations il faut modifier les points de réglage comme suit : remplacer 7 par 4, 6 par 3, 3 par 6 et 4 par 7.

