

LOOP 2.8X AT 600 KC

8.8X AT 600 KC

35X FROM 600 KC TO 455 KC

11X FROM 455 KC TO

IU4 R.F.

IL6 CONVERTER

IU4 I.F.

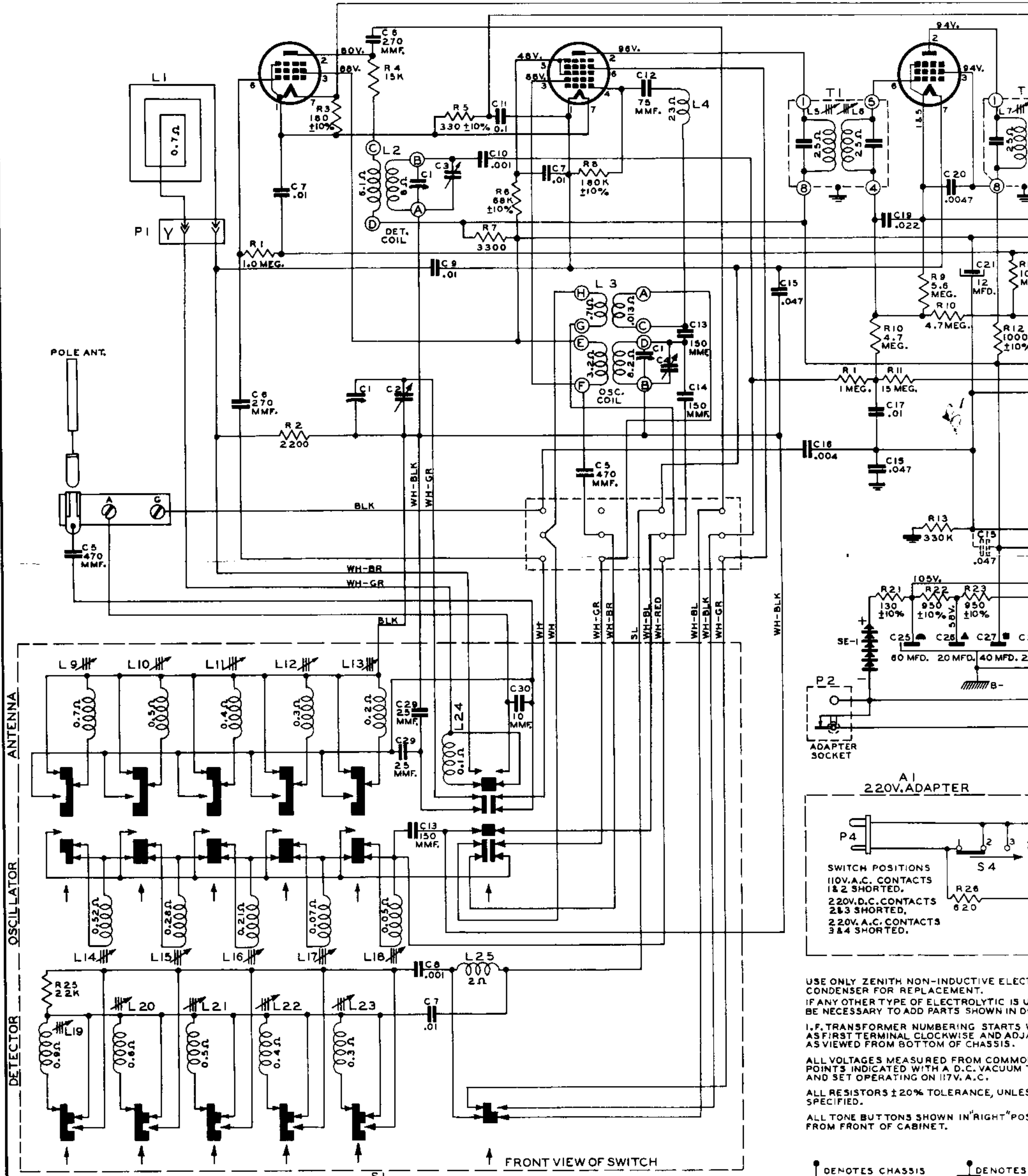

ANTENNA
OSCILLATOR
DETECTOR

BAND SELECTOR SWITCH, COIL AND WIRE ASSEMBLY
BAND SWITCH BUTTONS SHOWN IN NON-OPERATED "OUT" POSITION

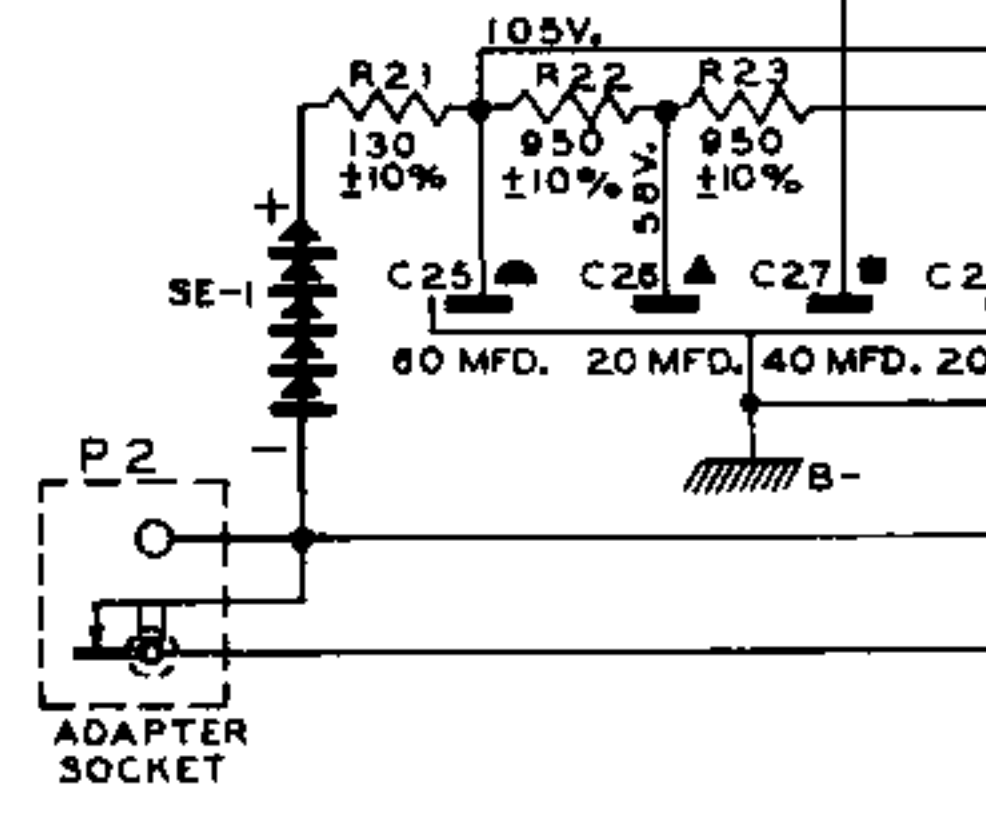

A1 220V ADAPTER

SWITCH POSITIONS
110V. A.C. CONTACTS 1 & 2 SHORTED.
220V. D.C. CONTACTS 2 & 3 SHORTED.
220V. A.C. CONTACTS 3 & 4 SHORTED.

USE ONLY ZENITH NON-INDUCTIVE ELECTRIC CONDENSER FOR REPLACEMENT.
IF ANY OTHER TYPE OF ELECTROLYTIC IS USED, IT IS NECESSARY TO ADD PARTS SHOWN IN DOT.

I.F. TRANSFORMER NUMBERING STARTS WITH FIRST TERMINAL CLOCKWISE AND ADJACENT TERMINAL AS VIEWED FROM BOTTOM OF CHASSIS.

ALL VOLTAGES MEASURED FROM COMMON POINTS INDICATED WITH A D.C. VACUUM TUBE SET OPERATING ON 117V. A.C.

ALL RESISTORS ± 20% TOLERANCE, UNLESS SPECIFIED.

ALL TONE BUTTONS SHOWN IN "RIGHT" POSITION FROM FRONT OF CABINET.

⏏ DENOTES CHASSIS
⏏ DENOTES BATTERY

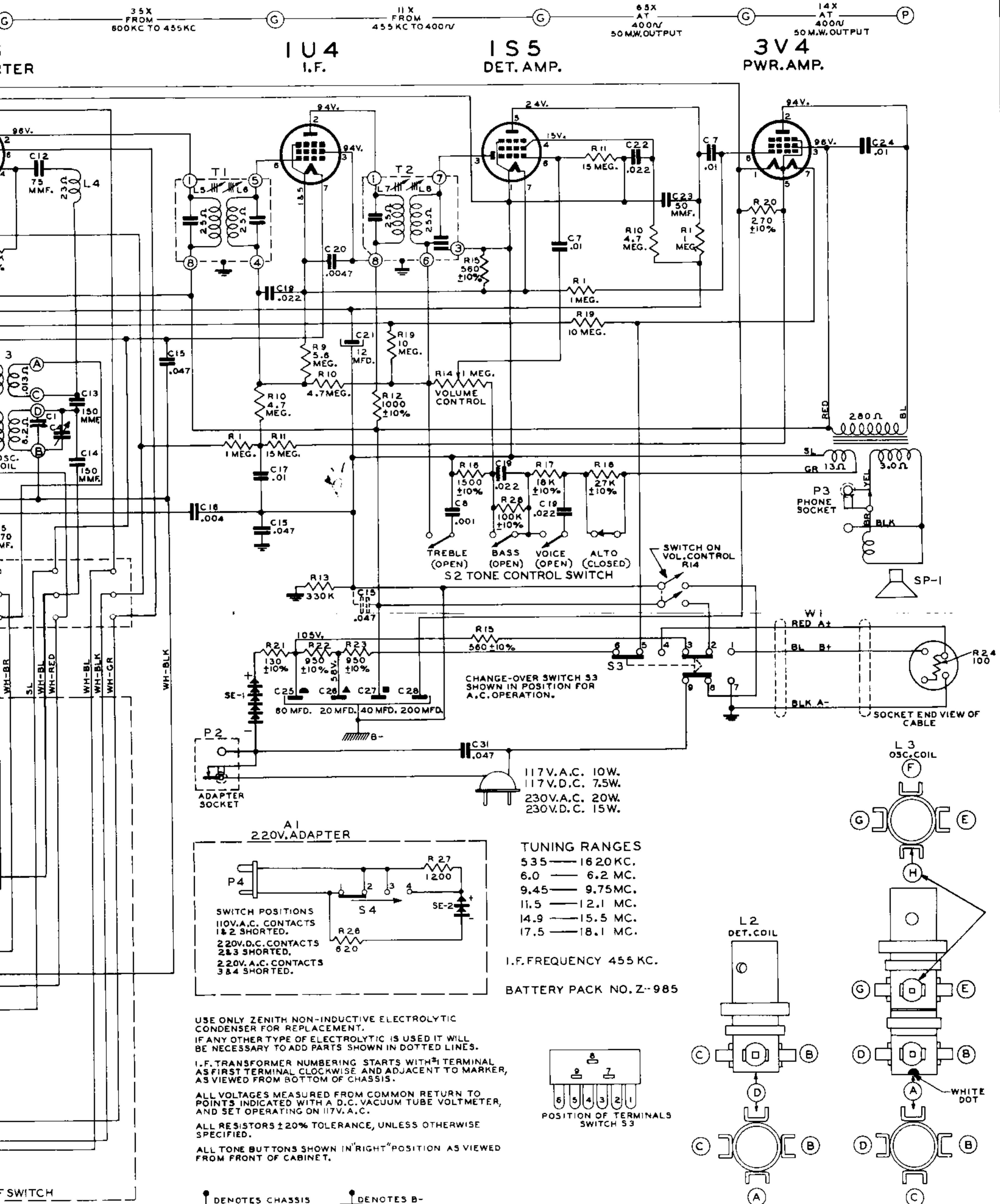

35X FROM 800KC TO 455KC 11X FROM 455 KC TO 400V 65X AT 400V 50M.W.OUTPUT 14X AT 400V 50M.W.OUTPUT

1U4
I.F.

1S5
DET. AMP.

3V4
PWR. AMP.

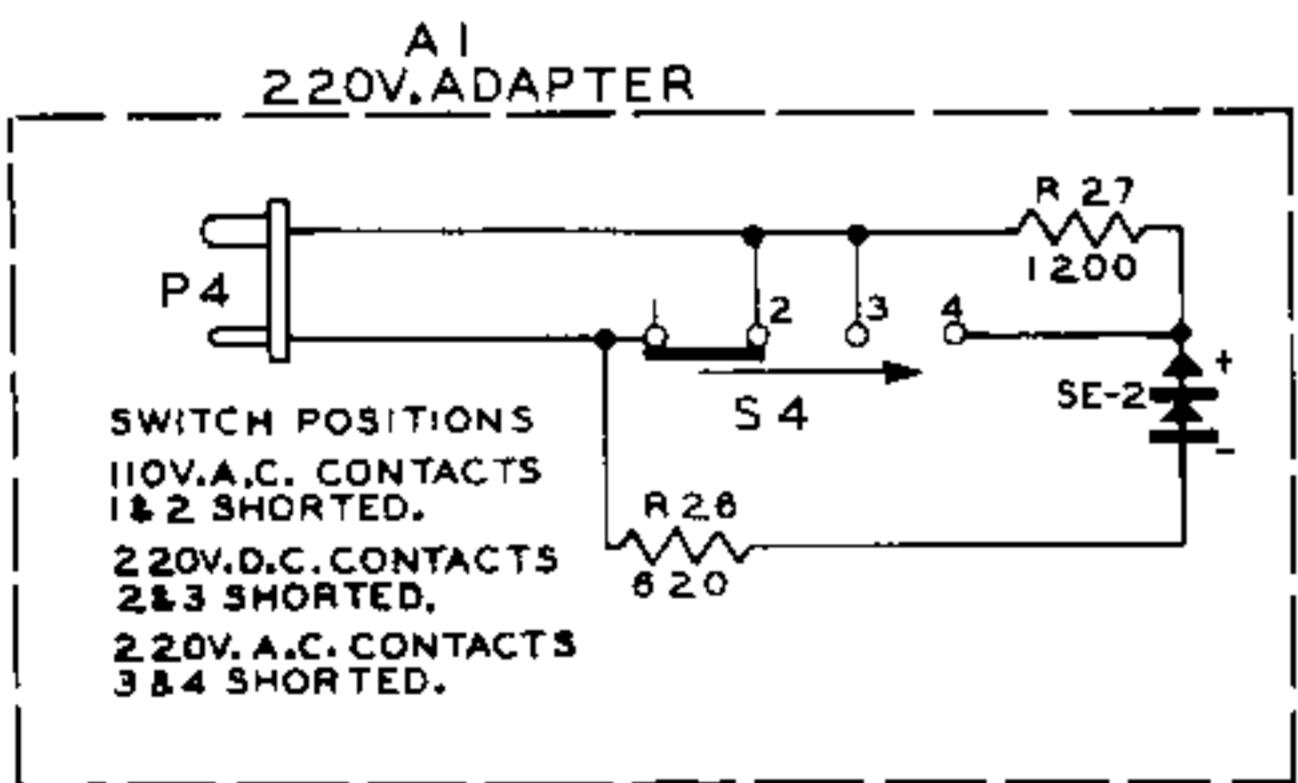

- TUNING RANGES**
- 5.35 — 16.20 KC.
 - 6.0 — 6.2 MC.
 - 9.45 — 9.75 MC.
 - 11.5 — 12.1 MC.
 - 14.9 — 15.5 MC.
 - 17.5 — 18.1 MC.

I.F. FREQUENCY 455 KC.
 BATTERY PACK NO. Z-985

USE ONLY ZENITH NON-INDUCTIVE ELECTROLYTIC CONDENSER FOR REPLACEMENT. IF ANY OTHER TYPE OF ELECTROLYTIC IS USED IT WILL BE NECESSARY TO ADD PARTS SHOWN IN DOTTED LINES.

I.F. TRANSFORMER NUMBERING STARTS WITH #1 TERMINAL AS FIRST TERMINAL CLOCKWISE AND ADJACENT TO MARKER, AS VIEWED FROM BOTTOM OF CHASSIS.

ALL VOLTAGES MEASURED FROM COMMON RETURN TO POINTS INDICATED WITH A D.C. VACUUM TUBE VOLTMETER, AND SET OPERATING ON 117V. A.C.

ALL RESISTORS ±20% TOLERANCE, UNLESS OTHERWISE SPECIFIED.

ALL TONE BUTTONS SHOWN IN "RIGHT" POSITION AS VIEWED FROM FRONT OF CABINET.

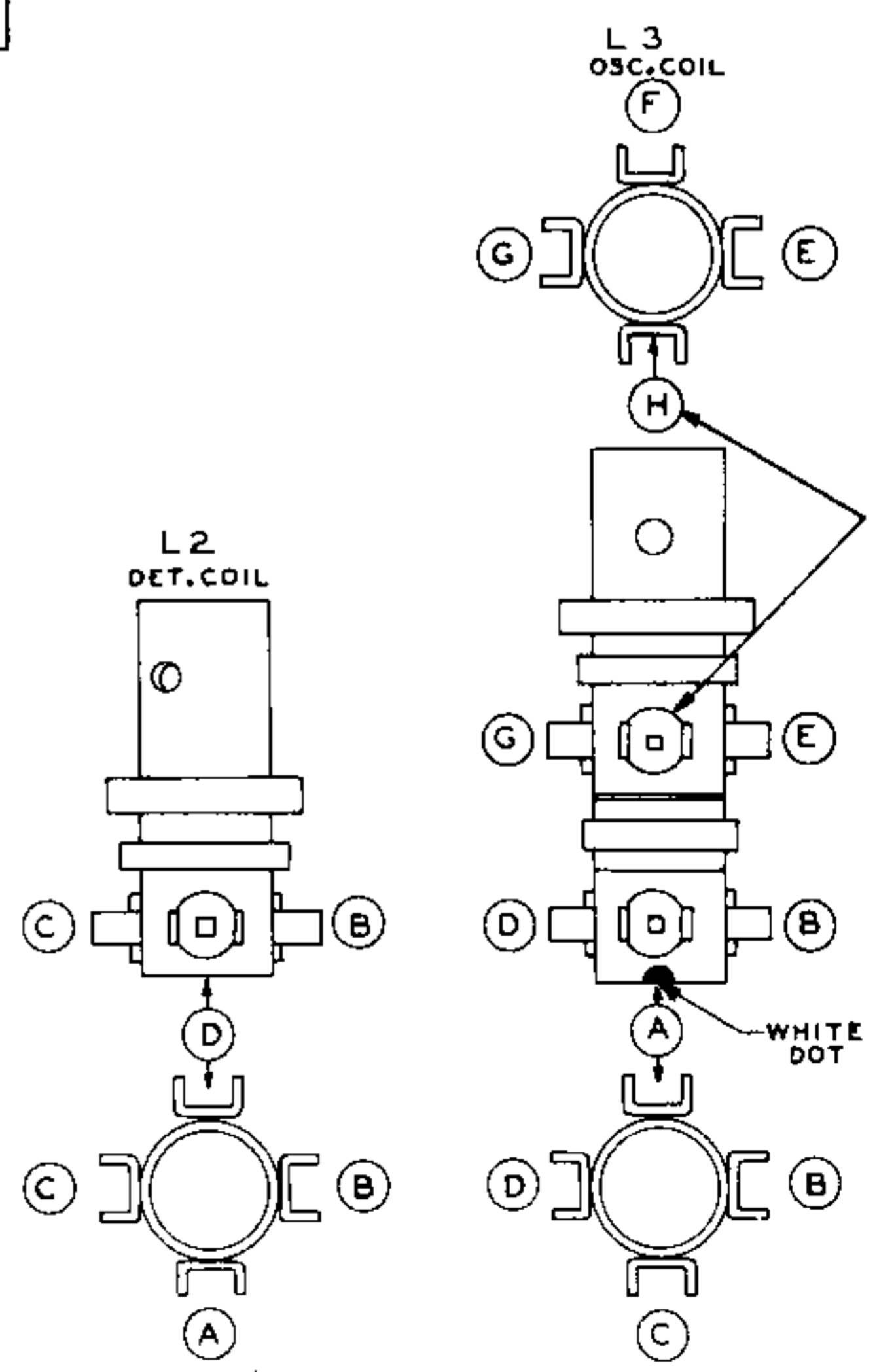
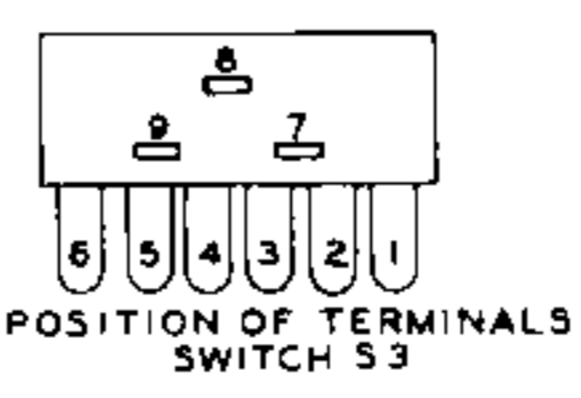

⊥ DENOTES CHASSIS ⊥ DENOTES B-

TO THE SERVICE MAN:

Chassis 5G40 features a high gain tuned RF stage ahead of a conventional superheterodyne circuit with band spread tuning on the 49, 31, 25, 19 and 16 meter bands.

If removal of the chassis from the cabinet ever becomes necessary this should be done with care.

The alignment of chassis 5G40 is conventional. However, care must be exercised when making adjustments, and the alignment procedure must be followed exactly. Set the chassis over a metal plate approximately the same distance the battery pack is from the bottom of the chassis when it is in the cabinet. This procedure will introduce the approximate amount of metal in the field of the RF and oscillator coils as when the chassis is in the cabinet. A signal generator of reasonable accuracy and good attenuation must be used. An output meter (AC) of the copper oxide rectifier type with a range of 1 to 30 volts in several steps is necessary to get accurate output readings. Alignment wrenches should be of the non-metallic type, especially when making adjustments at the higher frequencies.

When reinstalling the chassis in the cabinet be careful not to disturb the cabling between the short wave coil assembly and chassis. Tune in a weak broadcast signal near 1400 Kc. and touch up trimmer C2. This will insure maximum performance after alignment.

The I.F. transformers incorporated in this receiver are of the new permeability tuned type. The advantage of an I.F. transformer of this type is its extreme stability under various humidity and temperature conditions. The upper coil is the secondary and the lower the primary. When adjusting these I.F. transformers the tuning wrench 68-7 can be inserted into the top slug, rotated until maximum output is obtained and then dropped down to the lower slug and the same operation repeated. The tuning wrench is so designed that turning one slug does not affect the adjustment of the other.

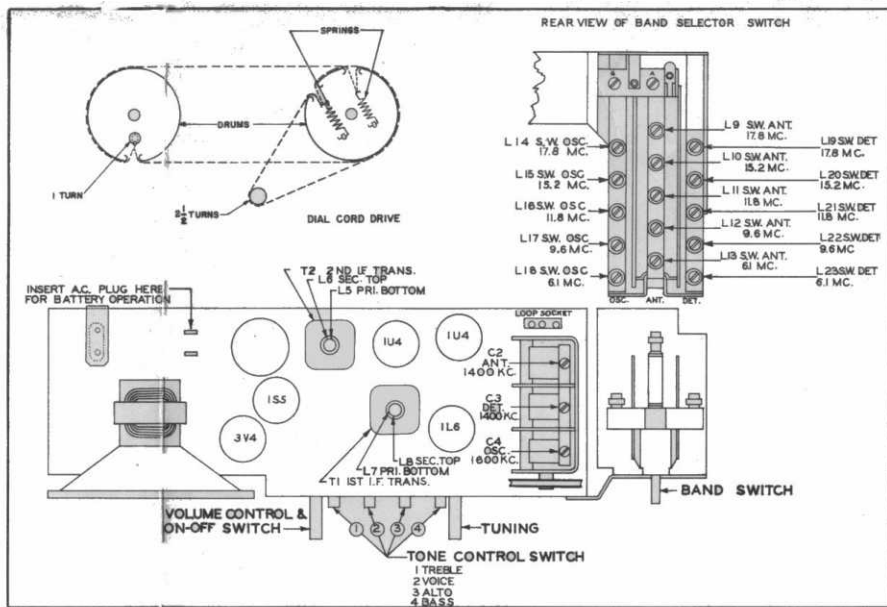

TUBE, TRIMMER LOCATION AND DIAL CABLE DRAWING

ALIGNMENT PROCEDURE

OPERATION	CONNECT OSCILLATOR TO	DUMMY ANTENNA	INPUT SIG. FREQUENCY	BAND	SET DIAL AT	TRIMMERS	PURPOSE
1	Positive lead of signal generator to converter grid through a .1 MFD condenser and negative lead to negative filament of 1L6 tube.		455 Kc.	BC	600 Kc.	L5, 6, 7, 8	Align I.F.
2			1600 Kc.	BC	1600 Kc.	C4	Set Oscillator to Scale
3	One turn loop Coupled loosely to Broadcast Wavemagnet		1400 Kc.	BC	1400 Kc.	C3	Alignment of Detector
4			1400 Kc.	BC	1400 Kc.	C2	Alignment of B.C. Wavemagnet
5*	3 feet of wire Approx. 1 foot from Extended Wavemagnet		6.1 Mc.	49 Met.	6.1 Mc.	L18, 23, 13	Alignment of S.W. Oscillator, detector and antenna
6*			9.6 Mc.	31 Met.	9.6 Mc.	L17, 22, 12	
7*			11.8 Mc.	25 Met.	11.8 Mc.	L16, 21, 11	
8*			15.2 Mc.	19 Met.	15.2 Mc.	L15, 20, 10	
9*			17.8 Mc.	16 Met.	17.8 Mc.	L14, 19, 9	

*NOTE: Rock Tuning Condenser When Making Alignment Under Operations 5, 6, 7, 8 and 9.