

**MODEL R600 and R600L  
CHASSIS 6R40 and 6R41**

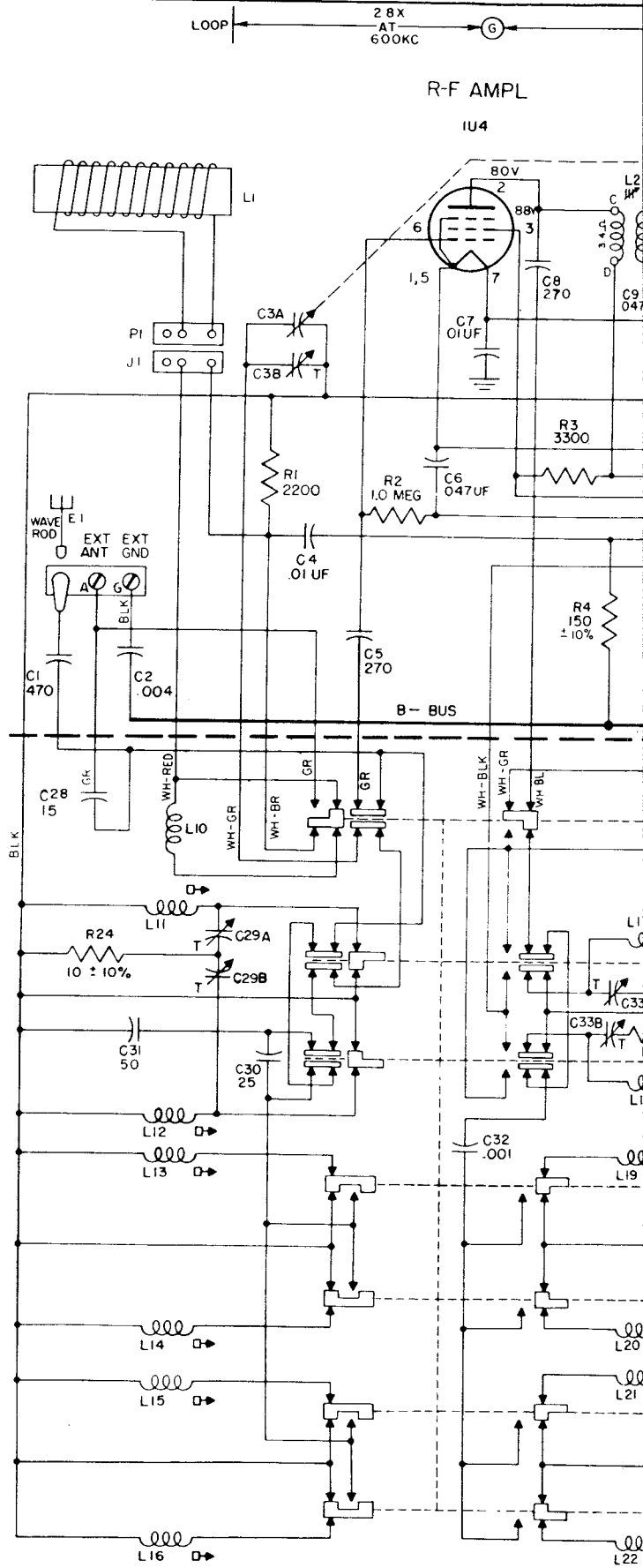

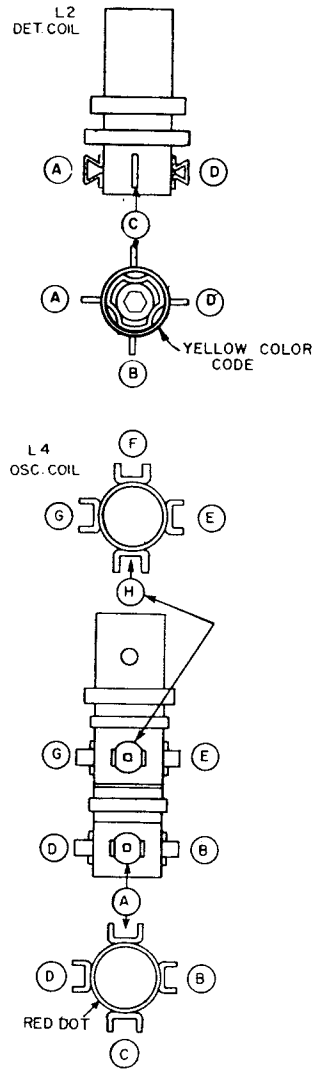
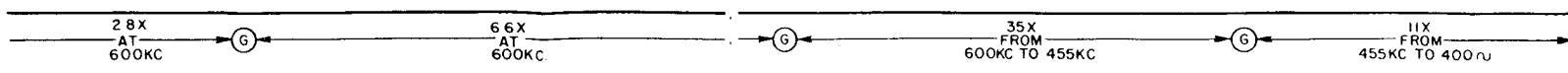

R-F AMPL

CONVERTER

I-F AMPL

DET-

IU4

IL6

IU4

IU5

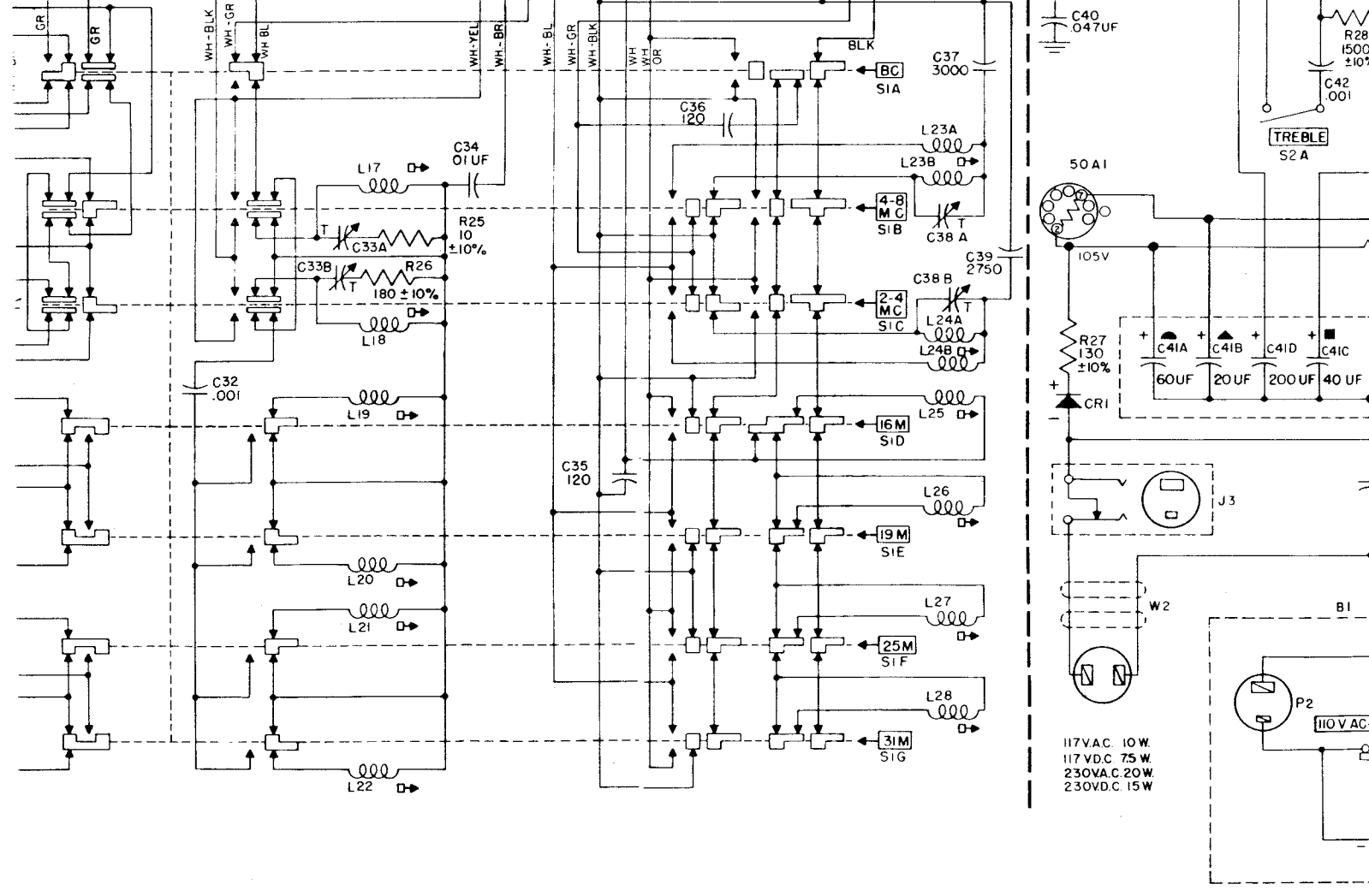
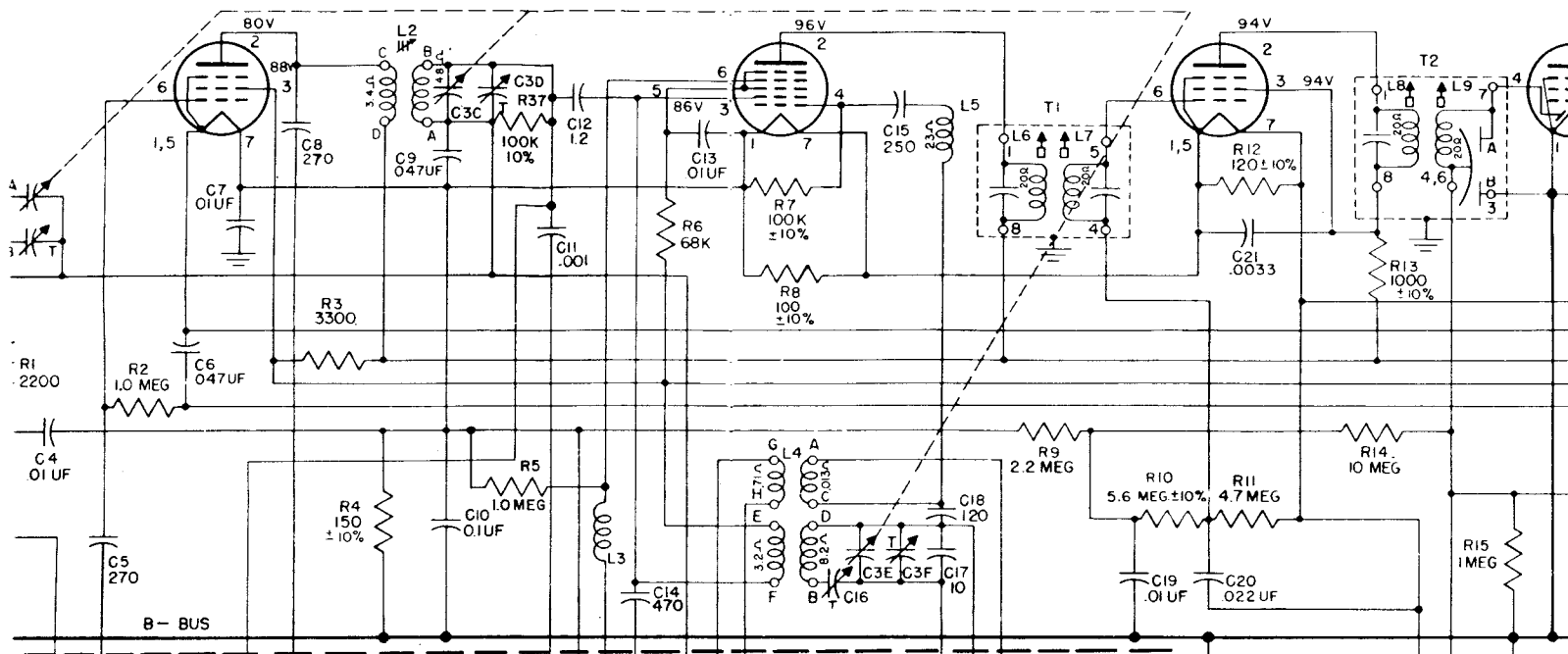

117VAC. 10W.  
117VDC. 75W.  
230VAC. 20W.  
230VDC. 15W

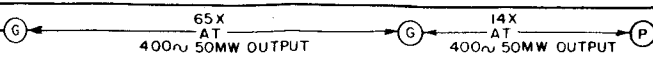

-AMPL

AUDIO OUTPUT

U5

3V4

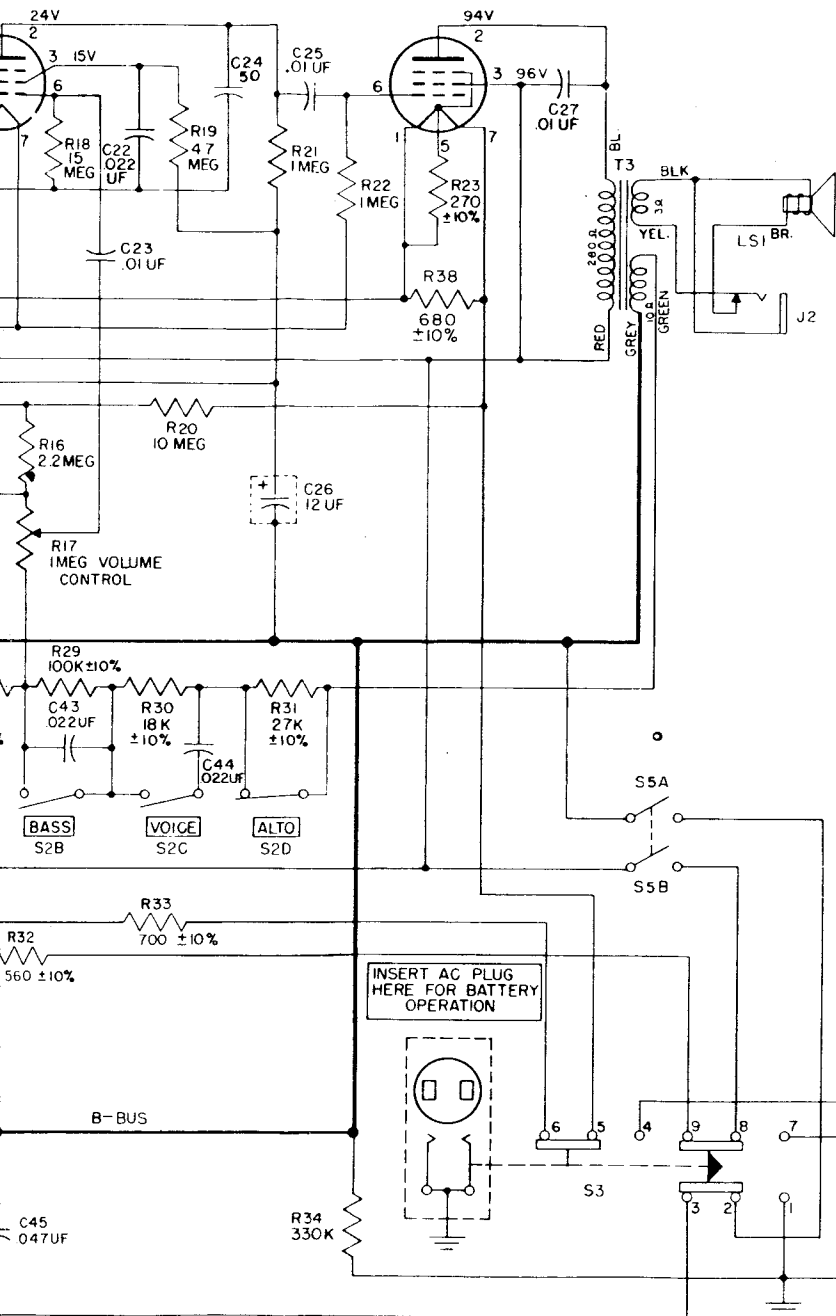

NOTES

- 1 RESISTOR VALUES IN OHMS, CAPACITY VALUES IN UUF UNLESS OTHERWISE SPECIFIED.
- 2 IF TRANSFORMER NUMBERING STARTS WITH #1 TERMINAL AS FIRST TERMINAL CLOCKWISE AND ADJACENT TO MARKER, AS VIEWED FROM THE BOTTOM OF CHASSIS
- 3 ALL SECTIONS OF BAND SELECTOR SWITCH S1 SHOWN IN NONOPERATING POSITION. IN OPERATING POSITIONS SLIDING CONTACTS MOVE TO THE LEFT.
- 4 ALL TONE BUTTONS S2 SHOWN IN RIGHT POSITION AS VIEWED FROM THE FRONT OF CABINET
- 5 S3 POWER CHANGEOVER SWITCH SHOWN IN POSITION FOR POWER LINE OPERATION
- 6 POWER ADAPTER SWITCH S4 SHOWN IN 110 VOLTS AC-DC POSITION
- 7 ALL VOLTAGES MEASURED FROM COMMON RETURN TO POINTS INDICATED WITH A D.C. VACUUM TUBE VOLTMETER AND SET OPERATING ON 117V. A.C.

TUNING RANGES

540	—	1600 KC
4 MC	—	8 MC
2 MC	—	4 MC
174	—	18.2 MC
148	—	15.6 MC
115	—	12.1 MC
94	—	9.8 MC

I.F. FREQUENCY 455 KC  
BATTERY PACK NO. Z-985

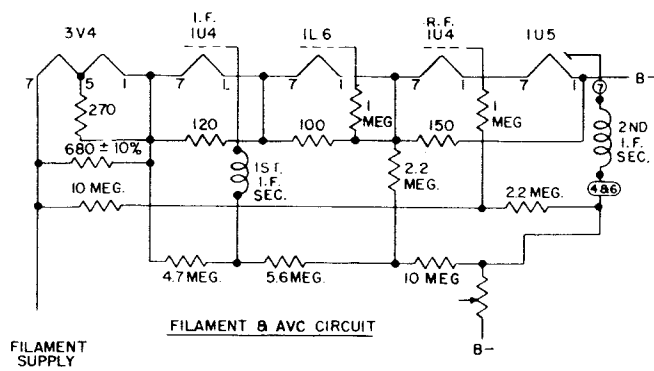
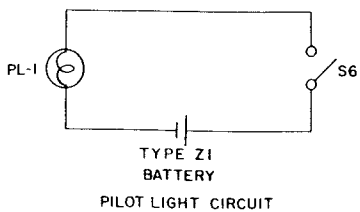
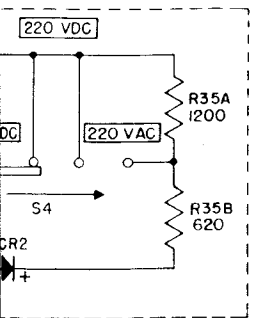

Chassis 6R40 features a high gain tuned RF stage ahead of a conventional superheterodyne circuit with band spread tuning on the 31, 25, 19 and 16 meter bands. There are two continuous coverage bands, one covering 2-4 megacycles and one covering 4-8 megacycles.

If removal of the chassis from the cabinet ever becomes necessary this should be done with care.

The alignment of chassis 6R40 is conventional. However, care must be exercised when making adjustments, and the alignment procedure must be followed exactly. Set the chassis over a metal plate approximately the same distance the battery pack is from the bottom of the chassis when it is in the cabinet. This procedure will introduce the approximate amount of metal in the field of the RF and oscillator coils as when the chassis is in the cabinet. A signal generator of reasonable accuracy and good attenuation must be used. An output meter (AC) of the copper oxide rectifier type with a range of 1 to 30 volts in several steps is necessary to get accurate output readings. Alignment wrenches should be of the non-metallic type, especially when making adjustments at the higher frequencies.

When reinstalling the chassis in the cabinet be careful not to disturb the coupling between the short wave coil assembly and chassis. Tune in a weak broadcast signal near 1400 Kc. and touch up trimmer C3B. This will insure maximum performance after alignment.

The I.F. transformers incorporated in this receiver are of the new permeability tuned type. The advantage of an I.F. transformer of this type is its extreme stability under various humidity and temperature conditions. The upper coil is the secondary and the lower the primary. When adjusting these I.F. transformers the tuning wrench 68-19 can be inserted into the top slug, rotated until maximum output is obtained and then dropped down to the lower slug and the same operation repeated. The tuning wrench is so designed that tuning one slug does not affect the adjustment of the other.

Thermal Regulator Tube 50A1 is an automatic rheostat designed to keep the current in a circuit at a definite value. Should the supply voltage change, either upward or downward, the Thermal Regulator will automatically increase or decrease its resistance to compensate for this change and keep the current thru the controlled circuit at a constant value.

As used in the R600, the controlled circuit consists of the filament of the five vacuum tubes connected in series. A constant current thru these filaments is equivalent to a constant voltage applied across them.

The Thermal Regulator tube is capable of performing its function because of its peculiar electric thermal characteristics. Basically the tube consists of a fine iron wire filament hermetically sealed in a hydrogen atmosphere. By balancing the temperature resistance curve of the wire against the thermal conductivity curve of the gas, it is possible to make a unit that automatically changes its resistance to keep a constant current flowing over a large range of voltage variation.

By keeping the filament current of the vacuum tubes constant at 50 milliamperes we extend the line voltage range over which the set will operate from 90 to 130 volts and increase tube life by an indefinite amount.

ALIGNMENT PROCEDURE

OPER.	CONNECT TO DUMMY ANTENNA	INPUT SIG. FREQ.	BAND	SET DIAL AT	TRIMMERS	PURPOSE
1	Positive lead of signal generator to converter grid through a .1 Mfd. condenser & negative lead to negative filament of 1L6 tube.	455 Kc	BC	600 Kc	L6,7,8,9	Align I.F.
2	One turn loop coupled loosely to broadcast wavemagnet	1600 Kc	BC	1600 Kc	C3F	Set oscillator to scale
3		1400 Kc	BC	1400 Kc	C3D	Alignment of selector
4		1400 Kc	BC	1400 Kc	C3B	Alignment of BC ant.
5*		600 Kc	BC	600 Kc	Rock C16	Align 1 of BC at 600 Kc
6		7.8 Mc	4-8 Mc	7.8 Mc	C38A, C33A, C29A	Alignment of S. W. Oscillator Detector and Antenna.
7*	4.2 Mc	4-8 Mc	4.2 Mc	Rock L23B		
8	REPEAT OPERATIONS 6 & 7					
9	3.9 Mc	2-4 Mc	3.9 Mc	C38B, C33B, C29B		
10*	2.1	2-4 Mc	2.1 Mc	Rock L24B		
11	REPEAT OPERATIONS 9 & 10					
12	17.8 Mc	16 Meters	17.8 Mc	L25, L19, L13		
13*	15.2	19 Meters	15.2	L26, L20, L14		
14	11.8 Mc	25 Meters	11.8	L27, L21, L15		
15*	9.6 Mc	31 Meters	9.6 Mc	L28, L22, L16		

\* NOTE: Rock Tuning Condenser When Making Alignment Under Operations 5, 7, 10, 12, 13, 14 & 15. NOTE: If Trimmers C2, C3, C4 are adjusted after procedures No. 2 through No. 15 are completed, it will be necessary to repeat alignment procedures No. 2 through No. 15.



PART NO.	DIAG. NO.	DESCRIPTION Chassis Parts	PRICE
12-1873		Bracket (part of S-20821)	.05
12-2053		Dial support bracket	.06
12-2054		Pointer shaft bracket	.15
12-2056		Tuning shaft bracket	.02
15-57		Cap & insulator (part of S-15785)	.10
19-189		Coil mtg. clip	.02
19-249		Coil mtg. clip	.03
22-3	C7, 13, 23, 25, 34	.01 Mfd. ceramic 500V (5 used)	.26
22-4	C2	.004 Mfd. ceramic 500V	.26
22-1390	C1, 14	.470 Mmf. mica 500V (2 used)	.26
22-1392	C30	.75 Mmf. ceramic 500V	.33
22-1433	C39	2750 Mmf. mica 500V	.65
22-1674	C24	50 Mmf. ceramic 500V	.20
22-1741	C41A, B, C, D	Electrolytic 20/150V, 40/150V, 60/150V, 200/10V	4.65
22-1761	C31	50 MMfd. ceramic 500V	.20
22-1765	C12	1.2 Mmf. molded 500V	.20
22-1775	C9, 40	.047 Mfd. paper 400V (2 used)	.26
22-1777	C10	.1 Mfd. paper 200V	.26
22-1778	C6	.047 Mfd. paper 200V	.26
22-1779	C27	.01 Mfd. paper 600V	.26
22-1780	C21	.0033 Mfd. paper 400V	.26
22-1784	C4	.01 Mfd. paper 400V	.20
22-1846	C19	.01 Mfd. paper 400V	.20
22-1953	C17	10 Mmf. ceramic 500V	.35
22-2056	C26	Electrolytic 12/150V	1.20
22-2058	C5, 8	270 Mmf. mica 500V (2 used)	.26
22-2071	C20, 43, 44	.022 Mfd. paper 200V (3 used)	.26
22-2072	C22	.022 Mfd. paper 400V	.26
22-2126	C15	250 Mmf. ceramic 500V	.26
22-2127	C32, 42	.001 Mfd. paper 600V (2 used)	.26
22-2218	C11	.001 Mfd. ceramic 500V	.35
22-2279	C18, 35	120 Mmf. ceramic 500V (2 used)	.30
22-2280	C36	120 Mmf. ceramic 500V	.35
22-2281	C37	3000 Mmf. mica 500V	.55
22-2282	C16	Single section trimmer	.70
22-2283	C38A, C38B	2 section trimmer	.55
22-2284	C33A, C33B	2 section trimmer	.55
22-2285	C29A, C29B	2 section trimmer	.65
22-2329	C28	15 Mmf. ceramic 500V	.20
22-2520	C3A, B, C, D, E, F	3 section variable	5.75
22-2569	C45	.047 Mfd. paper 600V	
26-520		Dial scale (used on 6R40)	3.50
26-530		Dial scale (used on 6R41)	3.75
44-29	J2	Headphone jack	.75
49-748	LS1	5 1/4" PM speaker	10.00
54-34		6-32 x 1/4 x 3/32 hex nut (2 mt. ea. 95-1148, 95-1149 & 212-13)	.01
54-139		3/8 x 32 x 9/16 palnut	.01
57-1911		Trim plate (used on 85-543)	.10
57-1986		Scale background plate (used on 6R40)	.45
57-2030		Scale background plate (used on 6R41)	.75
58-182	P2	Adapter plug on S-15715	
59-300		Dial pointer	.50
61-137		Idler pulley (3 part of S-20793)	.10
63-1701	R24, 25	10 ohm 1/2W Ins. 10% (2 used)	.16
63-1743	R8	100 ohm 1/2W Ins. 10%	.16
63-1744	R36	100 ohm 1/2W Ins. 20%	.16
63-1747	R12	1200 ohm 1/2W Ins. 10%	.16
63-1750	R4	150 ohm 1/2W Ins. 10%	.16
63-1754	R26	180 ohm 1/2W Ins. 10%	.16
63-1761	R23	270 ohm 1/2W Ins. 10%	.16
63-1775	R32	560 ohm 1/2W Ins. 10%	.16
63-1778	R38	680 ohm 1/2W Ins. 10%	.16
63-1785	R13	1000 ohm 1/2W Ins. 10%	.16
63-1792	R28	1500 ohm 1/2W Ins. 10%	.16
63-1800	R1	2200 ohm 1/2W Ins. 20%	.16
63-1807	R3	3300 ohm 1/2W Ins. 20%	.16
63-1838	R30	18 K ohm 1/2W Ins. 10%	.16
63-1845	R31	27 K ohm 1/2W Ins. 10%	.16
63-1863	R6	68 K ohm 1/2W Ins. 20%	.16
63-1869	R7, 29, 37	100 K ohm 1/2W Ins. 10% (3 used)	.16
63-1891	R34	330 K ohm 1/2W Ins. 20%	.16
63-1912	R2, 5, 15, 21, 22	1 Megohm 1/2W Ins. 20% (5 used)	.16
63-1926	R9, 16	2.2 Megohm 1/2W Ins. 20% (2 used)	.16
63-1940	R11, 19	4.7 Megohm 1/2W Ins. 20% (2 used)	.16
63-1943	R10	5.6 Megohm 1/2W Ins. 10%	.16
63-1954	R14, 20	10 Megohm 1/2W Ins. 20% (2 used)	.16
63-1961	R18	15 Megohm 1/2W Ins. 20%	.16
63-2276	R17	Volume control & switch	1.81
63-2395	R35A, R35B	Candohm (part of S-15715)	
63-2839	R27	130 ohm 3W Ins. 10%	.50
63-2930	R33	700 ohm 3W WW 10%	.35
64-306		Shoulder rivet (1 mt. ea. 61-137)	.03
78-274		Electrolytic socket	.03
78-543	J4	4 contact socket (part of S-15785)	.13
78-802	J1	Wavemagnet ant. socket	.10
78-806		Miniature tube socket	.15
78-807		Miniature tube socket (4 used)	.15
78-844		Adapter socket (220V)	.25
78-846		Novel miniature tube socket	.20
80-69		Dial cord tension spring (1 used on ea. S-20783 & S-20805)	.05
80-209		Dial cord tension spring (used on S-20784)	.03
83-1102		2 Lug Terminal Strip	.05
83-1071		Threaded Retaining Strip (1 used on ea. 149-86)	.02
83-1880		Ant. Terminal Strip (part of S-17806)	.20
83-1919		2 Lug Terminal Strip	.05
83-2190		7 Lug Terminal Strip	.15
83-2307		4 Lug Terminal Strip	.06
85-473	S4	3 Position Switch on S-15715	
85-502	S1	Band Switch (part of S-20821)	12.25
85-503	S2	Tone Control Switch	1.00
85-543	S3	Power Change-Over Switch	1.40
or 85-520	S3	Power Change-Over Switch	1.00
93-2		Brass Washer (2 mt. ea. 78-802 & 84-4)	.01
93-125		Internal Lockwasher (2 mt. ea. 95-1148 & 95-1149, 1 mt. 212-13)	.01
93-158		1/8 x .142 x .318 Steel Washer (used on 212-13)	.05
93-209		.031 x .140 x 7/16 Steel Washer (2 mt. 26-520)	.02
94-295		Gang Capacitor & Speaker Mtg. Bushing (3 used on ea. 22-2520 & 49-748)	.04
94-742		Tuning Slug Insert (1 part of ea. S-17730 & S-17731)	.09
94-773		Insert (1 part of ea. S-18614 & S-18615; 2 on S-18735)	.06
94-812		Coil Insert Bushing (part of S-20844)	.05
95-1148	T1	1st IF Transformer	1.60
95-1149	T2	2nd IF Transformer	1.60
95-1369	T3	Audio Output Transformer (part of 49-748)	2.50
113-8		6-32 x 1/4 x 1/4 Hex Hd. Mach. Screw (lockwasher att.- 11 used)	.02
113-13		6-32 x 7/16 x 1/4 Hex Hd. Mach. Screw (lockwasher att.- 1 mt. 22-2520 & 3 mt. 49-748)	.02
113-18		6-32 x 5/16 Hex Hd. Mach. Screw (lockwasher att.- used on 12-1873)	.02
113-19		6-32 x 9/16 x 1/4 Hex Hd. Mach. Screw	.02
113-56		4-40 x 1/4 Hex Hd. Mach. Screw (lockwasher att.- 2 used)	.02
114-39		8-32 x 1/4 x 1/4 Hex Hd. Self-Tap Screw (mts. 12-2053)	.01
114-51		6-32 x 1/2 x 1/4 Hex Hd. Mach. Screw (2 mt. 22-2520)	.01

114-116		6-32 x 1/4 x 1/4 Hex Hd. Mach. Screw	
114-157		6-32 x 1/2 x 1/4 Hex Hd. Self-Tap Screw (2 mt. 26-520)	.01
114-297		6-32 x 1/4 x 1/4 Hex Hd. Self-Tap Screw (6 used)	.01
114-435		8 x 5/16 x 1/4 Hex Hd. Self-Tap Screw (flat washer att. 2 mt. S-20776)	.03
114-437		6-32 x 7/16 x 1/4 Hex Hd. Mach. Screw (2 mt. 26-520)	.02
125-17		Rubber Grommet	.03
139-96		Speaker Baffle (part of S-20790)	.25
149-85		Iron Core (part of S-20844)	.10
149-86		Iron Core (12 used)	.10
149-96		Iron Core (1 part of ea. S-17730, 17731, 18614 & 18615; 2 on S-18735)	.10
188-148		Retaining Ring (used on S-20794)	.02
188-149		Retaining Ring (used on S-20791)	.02
188-168		Retaining Ring (used on S-20794)	.06
196-174		Speaker Gasket (part of S-20790)	.25
212-9	CR2	Selenium Rectifier (part of S-15715)	
212-13	CR1	Selenium Rectifier	2.25
100-162		Thermal Resistor	
S-14403	L5	R.F. Choke Coil Assem.	.20
S-15785	W1	Battery Cable & Socket Assem.	.55
S-15715	B1	Voltage Adapter Assem. (available for this model)	4.20
S-17686		Coil Support Bracket Assem. (part of S-20821)	.25
S-17709	L4	Osc. Coil Assem. (B.C.)	1.00
S-17714	L19	RF Coil Assem. (16M)	.50
S-17715	L20	RF Coil Assem. (19M)	.50
S-17716	L21	RF Coil Assem. (25M)	.50
S-17717	L22	RF Coil Assem. (31M)	.50
S-17718	L13	Ant. Coil Assem. (16M)	.50
S-17719	L14	Ant. Coil Assem. (19M)	.50
S-17720	L15	Ant. Coil Assem. (25M)	.50
S-17721	L16	Ant. Coil Assem. (31M)	.50
S-17726	L25	Osc. Coil Assem. (16M)	.50
S-17727	L26	Osc. Coil Assem. (19M)	.50
S-17728	L27	Osc. Coil Assem. (25M)	.50
S-17729	L28	Osc. Coil Assem. (31M)	.50
S-17730	L23A, L23B	Osc. Coil Assem. (4-8 M.C.)	.70
S-17731	L24A, L24B	Osc. Coil Assem. (2-4 M.C.)	.70
S-17806		Band Sw. Mtg. Bracket & Term. Assem. (part of S-20821)	.65
S-18614	L12, L18	RF Coil Assem. (2-4 M.C.)	.50
S-18615	L17	RF Coil Assem. (4-8 M.C.)	.50
S-18735	L11	RF Coil Assem. (4-8 M.C.)	.50
S-20776		A.C. Cord & Reel Assem.	7.50
S-20782		RF Terminal Strip Assem.	.35
S-20783		Drive Cord & Eyelet Assem. (Gang)	.08
S-20784		Drive Cord & Eyelet Assem. (Pointer)	.10
S-20790		Speaker, Baffle & Gasket Assem.	10.75
S-20791		Pointer, Pulley & Shaft Assem.	.35
S-20793		Dial Mtg. Bracket & Rivet Assem.	.55
S-20794		Drive Shaft & Pulley Assem.	.60
S-20805		Drive Cord & Eyelet Assem. (Idler)	.08
S-20820	L10	Ant. Loading Coil Assem.	.50
S-20821		Band Switch Bracket & Coil Assem.	45.00
S-20843	L3	RF Choke Coil Assem.	.40
S-20844	L2	Detector Coil Assem. (BC)	.60

## R600 CABINET PARTS LIST

PART NO.	DIAG. NO.	DESCRIPTION	PRICE
12-1082		Telescoping Ant. Mtg. Bracket	.06
12-2058		Inside Cover Hinge Bracket (2 part of S-20815)	.10
14-1633		Model R600 Portable Cabinet	
or 14-1772		Model R600 Portable Cabinet	
16-957		Packing Carton	
17-67		Telescoping Ant. Rod Ret. Clamp	.08
19-253		Battery Retaining Clip	
19-258		Retaining Clip (3 used)	.03
24-670		Inside Front Cover (Model R600) (Part of S-20815)	1.80
24-671		AC Plug Cover (Model R600)	.15
36-86		Cabinet Handle (part of 14-1633)	.85
40-73		Cabinet Back Cover Hinge (2 part of 14-1633)	.25
40-147		Inside Cover Stop Hinge	
43-233		Wavemagnet Ant. Housing (part of S-20813)	1.25
43-234		Cover Housing (part of S-20815)	1.65
46-912		Band Switch Knob (Model R600 - 7 used)	.10
46-913		Tuning Knob (Model R600)	.15
46-1242		Vol. Control Knob (Model R600)	.30
54-341		8-32 x 1/4 x 3/32 Hex Nut (2 mt. S-15802)	.02
54-369		Cable Retaining Nut (2 used)	.05
54-391		3/8 - 32 Hex Nut	
56-320		Inside Cover Hinge Pin (part of S-20815)	.20
57-1520		Adapter Socket Cover Plate	.15
57-1725		Emblem Plate (part of S-20815)	.20
57-2082		Escutcheon (Model R600)	
58-157		Battery Plug (used with 85-542)	.05
58-179	P1	3 Prong Plug (part of S-20809)	.15
64-18		Brass Eyelet (part of S-20809)	.01
69-108		6-32 x 1/4 Rd. Hd. Mach. Screw (2 part of S-20823)	.02
69-292		4-40 x 1/4 Phils. Rd. Hd. Mach. Screw (2 mt. 85-542)	.03
70-166		6 x 1/2 Phils. Rd. Hd. Wood Screw (1 mt. chassis)	.02
70-168		4 x 1/2 Phils. Rd. Hd. Wood Screw (3 mt. 57-2082)	.02
70-169		4 x 3/4 Phils. Rd. Hd. Wood Screw (4 mt. 57-2082)	.02
70-189		6 x 5/16 Rd. Hd. Wood Screw (1 mt. ea. 19-258)	.03
70-202		4 x 3/8 Phils. Binding Hd. Wood Screw	.04
70-214		6 x 1/2 Phils. Rd. Washer Hd. Wood Screw (6 used)	.04
72-115		3 x 3/8 Phils. Flat Hd. Wood Screw (2 used)	.03
72-121		4 x 3/8 Phils. Flat Hd. Wood Screw (8 used)	.20
78-985		Dial Light Socket	.03
80-976		Cover Return Spring (2 part of S-20815)	.10
83-1617		Pull Tab (part of S-20809)	.06
83-1876		Push Button Felt Strip	.15
83-2184		Wavemagnet Ant. Mtg. Strip (part of S-20823 - Model R600)	.30
83-2320		Felt Strip	
85-542	S6	Momentary Contact Switch (S.P.) (Model R600)	.40
93-126		Int. Lockwasher (2 mt. S-15802)	.01
93-132		.038 x 11/64 x 7/16 Steel Washer (2 used)	.01
93-1188		Shakeproof Lockwasher (2 used)	
93-1195		Brass Washer	
97-367		Handle Mtg. Stud (2 part of 14-1633)	.25
97-428		Wavemagnet Ant. Ret. Stud (2 part of S-20823)	.20
100-171	PL1	Pilot Light Bulb (78-985)	.20
112-419		Mach. Screw (2 part of 14-1633)	
112-919		Screw (2 used on S-21428)	.08
112-920		6-20 x 3/8 Phils. Binding Hd. Self-Tap Screw (4 part of S-20813)	.02
114-197		Hex Washer Hd. Self-Tap Screw (2 mt. chassis)	.02
114-294		6-20 x 1/4 x 1/4 Hex Hd. Self-Tap Screw (4 part of S-20815)	.02
114-446		6-32 x 1/4 x 1/4 Hex Slotted Hd. Self-Tap Screw (used on 57-1520)	.02
156-42		Door Latch - Upper Half (part of 14-1633)	1.25
156-43		Door Latch - Lower Half (part of 14-1633)	1.25
157-7		Strike Fastener (2 part of 14-1633)	.08
157-8		Strike Fastener (2 part of 14-1633)	.05
159-49		Snap Button (4 used)	.01
166-75		Recessed Bumper (4 part of 14-1633)	.10

199-160 or		Ant. Ins. Sleeve (2 used)	.08
199-200		Ant. Ins. Sleeve (2 used)	.08
202-1011		Shortwave Chart Book (S-20815)	.85
202-1042		Special Booklet	.25
202-1071		Operating Guide	
202-1072		Service Notes	
S-15635		Wavemagnet Ant. Suction Cup Assem. (2 used)	.15
S-15722		Ant. Knob & Latch Spring Assem. (part of S-15802)	.45
S-15802	E1		
or S-22213		Telescoping Ant. Assem. (Model R600)	7.50
S-20799		Front Cover Hinge Assem. - Left (part of 14-1633)	.75
S-20800		Front Cover Hinge Assem. - Right (part of 14-1633)	.75
S-20809		Cable & Plug Assem. (part of S-20813)	.40
S-20811		Wavemagnet Ant. Wdg. Assem. (part of S-20813)	2.00
S-20813	L1	Complete Wavemagnet Ant. Assem. (Model R600)	4.90
S-20815		Inside Cover & Housing Assem. (Model R600)	5.40
S-20822		Wavemagnet Ant. Cover Assem. (Model R600)	1.30
S-20823		Wavemagnet Ant. Mtg. Strip Assem.	.55
Z985X		Complete Battery Pack	
S-18631		Headphone Kit (Available complete with 1-58-203 adaptor plug)	6.00

## R600L CABINET PARTS LIST

PART NO.	DIAG. NO.	DESCRIPTION	PRICE
12-1082		Telescoping Ant. Mtg. Bracket	.06
12-2058		Inside Cover Hinge Bracket (2 part of S-21426)	.10
14-1675		Model R600L Portable Cabinet	
16-957		Packing Carton	
17-67		Telescoping Ant. Rod Ret. Clamp	.08
19-253		Battery Retaining Clip	
19-258		Retaining Clip (3 used)	.03
24-695		Inside Front Cover (Model R600L - Part of S-21426)	1.95
24-696		AC Plug Cover (Model R600L)	.45
26-530		Dial Scale	
36-94		Cabinet Handle (part of 14-1675)	1.10
40-73		Cabinet back cover hinge (2 part of 14-1675)	.25
40-147		Inside Cover Stop Hinge	
43-244		Wavemagnet Housing (part of S-21428)	1.60
43-245		Cover Housing (part of S-21426)	1.80
46-1288		Band Switch Knob (7 used)	.10
46-1289		Tuning Knob	.30
46-1290		Volume Control Knob	.30
54-341		8-32 x 1/4 x 3/32 Brass Hex Nut (2 used on S-21433)	.02
54-369		Cable Retaining Nut (2 used)	.05
54-391		3/8-32 Hex Nut	
56-320		Inside Cover Hinge Pin (part of S-21426)	.20
57-1520		Adapter Socket Cover Plate	.15
57-1725		Emblem Plate (part of S-21426)	.20
57-2030		Scale Background Plate	
57-2083		Escutcheon	
58-157		Battery Plug (used with 78-985)	.05
58-179		Three Prong Plug (part of S-20809)	.15
64-18		Brass Eyelet (part of S-20809)	
69-108		6-32 x 1/4 Rd. Hd. Mach. Screw (2 part of S-21437)	.02
69-292		4-40 x 1/4 Phils. Rd. Hd. Mach. Screw (2 used)	.03
70-166		6 x 1/2 Phils. Rd. Hd. Wood Screw	.02
70-168		4 x 1/2 Phils. Rd. Hd. Wood Screw (3 used on 57-2083)	.02
70-169		4 x 3/4 Phils. Rd. Hd. Wood Screw (4 used on 57-2083)	.02
70-189		6 x 5/16 Rd. Hd. Wood Screw (used on 19-258)	.03
70-202		4 x 3/8 Phils. Mach. Screw	.04
70-214		6 x 1/2 Phils. Washer Hd. Wood Screw (5 on S-21437, 1 on 19-258)	.04
71-7		Phils. Ctr. Sk. Mach. Screw (2 each 156-42 and 156-43)	
72-115		3 x 3/8 Phils. flat hd. wood screw (2 used)	.03
72-121		4 x 3/8 Phils. flat hd. wood screw (6 used on S-21426) and (3 on 24-696)	.03
78-985		Dial light socket	.20
80-976		Cover return spring (2 part of S-21426)	.10
83-1617		Pull tap (part of S-20809)	.06
83-1876		Push button felt strip	.15
83-2252		Wavemagnet mtg. strip (part of S-21437)	.30
83-2320		Felt Strip	
85-550		Momentary contact switch (S.P.) (used with 78-985)	.45
93-126		Int. lockwasher (2 used on S-21433)	.01
93-132		.038 x 11/64 x 7/16 Steel washer (2 used)	.01
93-1188		Lockwasher (2 used)	
93-1195		Brass washer	
97-367		Handle mtg. stud (2 part of 14-1675)	.25
97-428		Wavemagnet retaining stud (2 part of S-21437)	.20
100-171		Pilot light bulb (78-985)	.20
112-419		Mach. Screw (2 part of 14-1675)	
112-919		Screw (2 used on S-21428)	.08
112-920		6-20 x 3/8 Phils. Self-Tap Screw (4 part of S-21428)	.02
114-197		Self-Tap Screw (2 used)	.02
114-294		6-20 x 1/4 x 1/4 Self-Tap Screw (4 part of S-21426)	.02
114-446		6-32 x 1/4 x 1/4 Hex Hd. Self-Tap Screw (used on 57-1520)	.02
156-42		Door latch - upper half (part of 14-1675)	1.25
156-43		Door latch - lower half (part of 14-1675)	1.25
157-7		Strike fastener (2 part of 14-1675)	.08
157-8		Strike fastener (2 part of 14-1675)	.05
159-49		Snap button (4 used)	.01
166-75		Recessed bumper (4 part of 14-1675)	.10
199-160		Ant. ins. sleeve	.08
202-1011		SW chart book (S-21426)	.85
202-1042		Special booklet	
202-1071		Operating guide	
202-1072		Service notes	
202-1073		Service notes supplement	
S-15635		Wavemagnet suction cup assem. (2 used)	.15
S-20809		Cable & Plug assem. (part of S-21428)	.40
S-20811		Wavemagnet wdg. assem. (part of S-21428)	2.00
S-21424		Front cover hinge assem. - left (part of 14-1675)	.85
S-21425		Front cover hinge assem. - right (part of 14-1675)	.85
S-21426		Inside cover & housing assem.	5.40
S-21427		Wavemagnet cover assem. (part of S-21428)	1.50
S-21428		Wavemagnet assem.	6.50
S-21432		Ant. knob & latch spring assem. (part of S-21433)	
S-21433		Telescoping ant. assem.	8.80
S-21437		Wavemagnet mtg. strip assem.	.70