

Emerson Radio

MODEL 888
"TRANSTIMER"
CHASSIS 120416

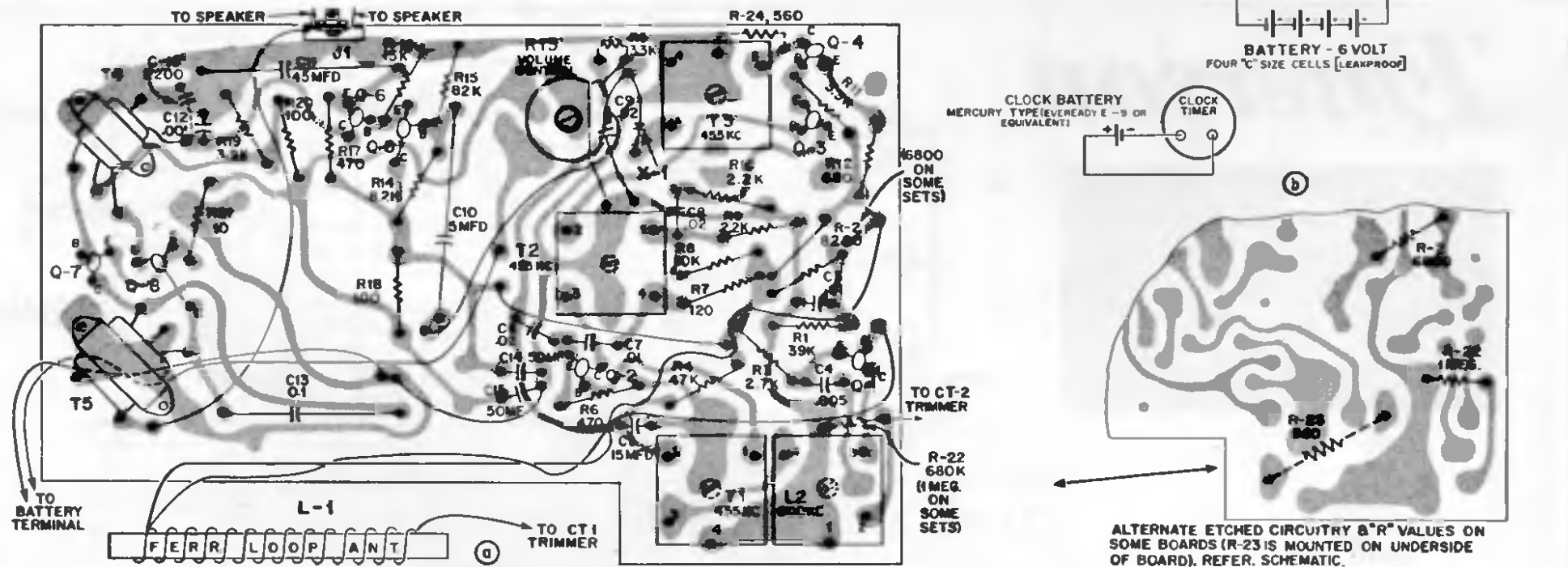
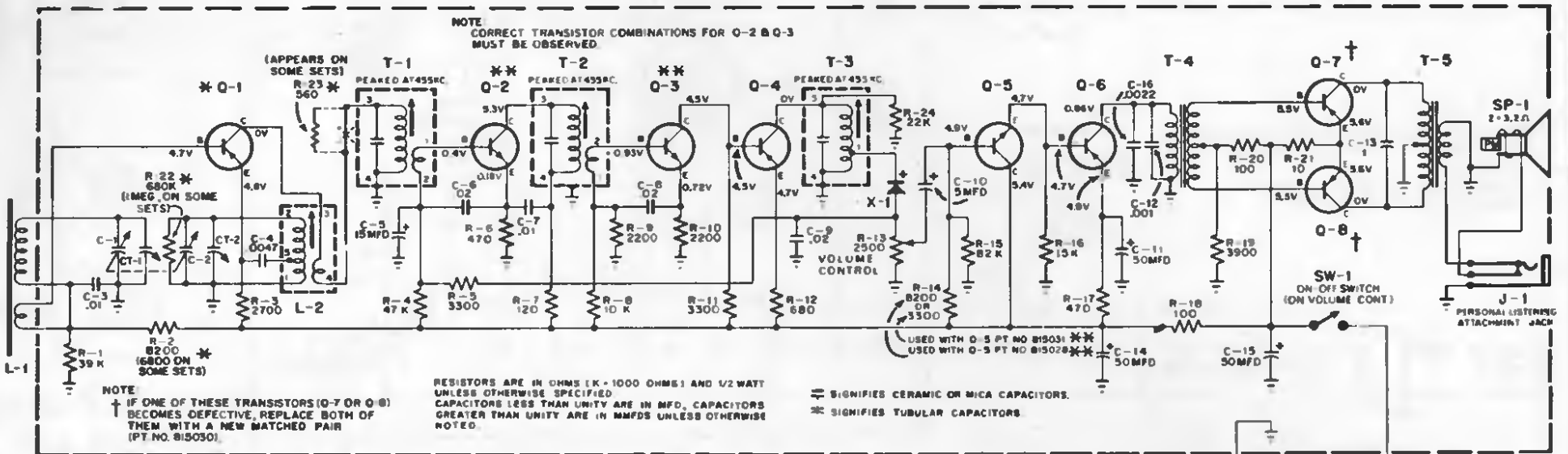

It will be seen from the schematic drawing of the 888 that certain transistors are used in pairs and are associated with specified resistors. Some individual transistors must likewise be used with specific resistors. Because of the small physical size of the transistors, the 1st three digits, "815", have been replaced by the letter, "E"

TRANSISTOR PAIRS		ASSOCIATED	TRANSISTOR PAIRS		ASSOCIATED	TRANSISTOR	ASSOCIATED	TRANSISTOR	ASSOCIATED
Q2	Q3	R12	Q2	Q3	R12	Q5	R14	Q5	R14
815026C	815026A	680	815026C	815026E	680	815031	3800	815033	6800
815026B	815026B	680	815026D	815026D	680	815028	8200	815034	8200
815026B	815026D	680	815026C	815026F	330	815032	4700	815035	10,000

TRANSISTOR SUBSTITUTES	TRANSISTOR NOS.	TRANSISTOR SUBSTITUTES	TRANSISTOR NOS.	TRANSISTOR SUBSTITUTES	TRANSISTOR NOS.
FDR	USE	FOR	USE	FOR	USE
815026B	815026D	815026F	No. Subst.	815033	815032
815026A	815026E	815028	815032	815034	815032
815026C	No Subst.	815031	815032	815035	815032

