

ICF-380

SERVICE MANUAL

US Model
Canadian Model
AEP Model
UK Model
E Model

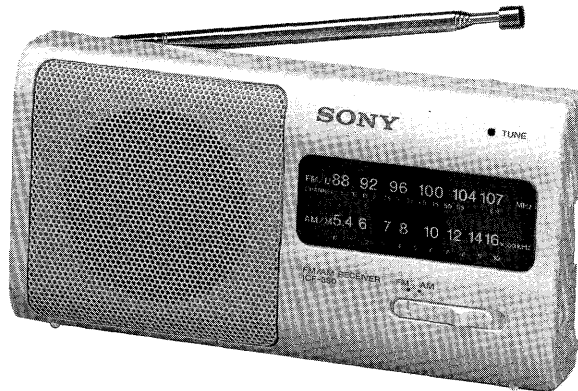

SPECIFICATIONS

Frequency range

	Frequency range	
	FM	AM
AEP, Germany, UK, E model	87.6 – 107.5MHz	531 – 1,602kHz
US, Canadian model	87.6 – 108MHz	530 – 1,710kHz
East European model	65 – 108MHz	531 – 1,602kHz

Intermediate frequency FM: 10.7 MHz

AM: 455 kHz

Antennas

FM: Telescopic antenna

AM: Built-in ferrite bar antenna

Speaker

Approx. 5.7 cm (2 1/4 inches) dia.

Power output

150 mW (at 10% harmonic distortion)

Output

Earphone jack (minijack)

Power requirements

3 V DC, two R6 (size AA) batteries

Battery life

Approx. 30 hours of listening (for four hours a day at a normal volume), using Sony batteries SUM-3 (NS)

Approx. 62 hours, using Sony alkaline batteries

AM3

Dimensions

Approx. 154.5 x 79 x 34.5 mm (w/h/d)

(6 1/8 x 3 1/8 x 1 3/8 inches)

incl. projecting parts and controls with the carrying handle pushed in

Weight

Approx. 260 g (9.2 oz), incl. batteries

Design and specifications subject to change without notice.



FM/AM RECEIVER
SONY®

SECTION 1
GENERAL

This section is extracted from instruction manual.

A Location of Controls

- 1 Speaker
 - 2 Dial scale
 - 3 Dial pointer
 - 4 BAND selector
 - 5 Telescopic antenna
 - 6 TUNE (tuning) indicator
 - 7 TUNE (tuning) control
 - 8 POWER/VOL (volume) control
Turn left to increase the volume.
 - 9 Carrying handle
 - 10 Battery compartment
 - 11 Ⓜ (earphone) jack
- The sound through the speaker cannot be heard when an earphone is connected to the jack.

A

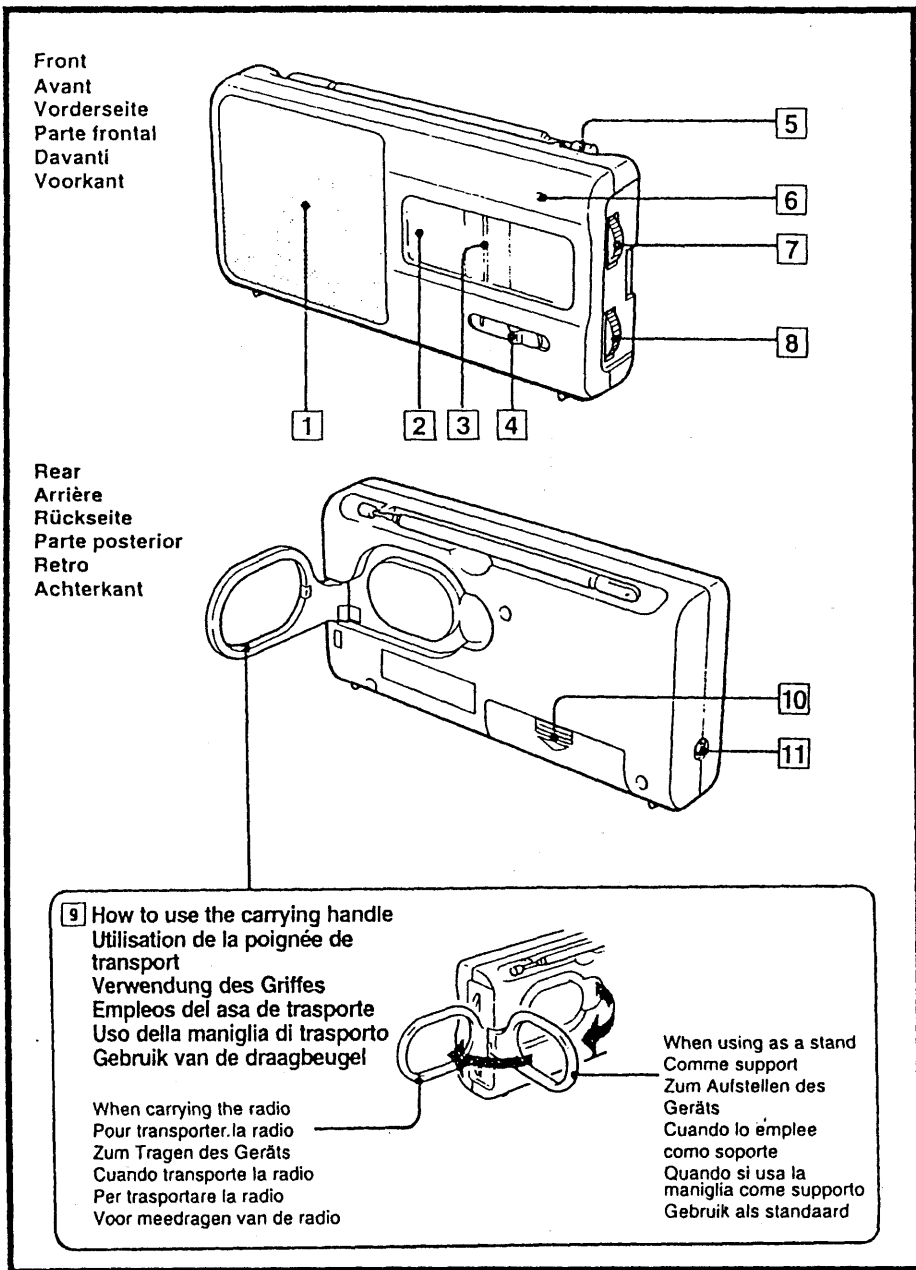

SEE ADDITIONAL INFORMATION

**SECTION 2
ADJUSTMENTS**

FM SECTION

BAND SWITCH : FM

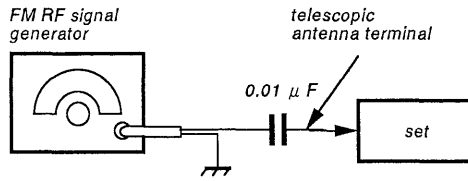

400Hz, 30% FM modulation
frequency deviation \pm 22.5kHz
Output level: as low possible

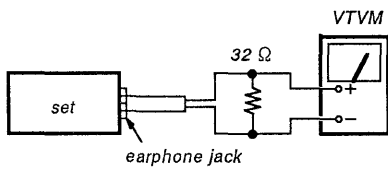

- Repeat the procedures in each adjustment several times, and the frequency coverage and tracking adjustments should be finally done by the trimmer capacitors.

FM FREQUENCY COVERAGE ADJUSTMENT	
Adjust for a maximum reading on VTVM.	
L4	86.5 (87.35) ((87.35)<64>) MHz
CT1-3	109.5 (108.5) ((108.5)<109.5>) MHz

FM TRACKING ADJUSTMENT	
Adjust for a maximum reading on VTVM.	
L2	86.5 (87.35) ((87.35)<68>) MHz
CT1-2	109.5 (108.5) ((108.5)<102>) MHz

AM SECTION

BAND SWITCH : AM

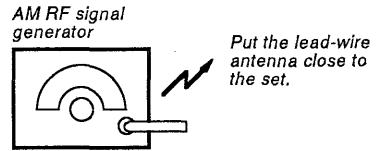

400Hz, 30% AM modulation
Output level: as low as possible

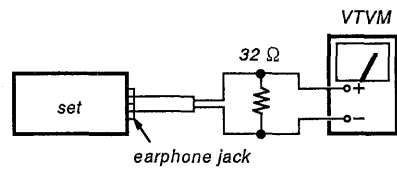

- Repeat the procedures in each adjustment several times, and the frequency coverage and tracking adjustments should be finally done by the trimmer capacitors.

AM FREQUENCY COVERAGE ADJUSTMENT	
Adjust for a maximum reading on VTVM.	
L5	520 (520) ((516.5)) kHz
CT1-4	1,750 (1,650) ((1,631.5)) kHz

AM TRACKING ADJUSTMENT	
Adjust for a maximum reading on VTVM.	
L1	600 (620) ((620)) kHz
CT1-1	1,400kHz

NOTE: no mark : US, Canadian model.
(): AEP, German, UK, E, Saudi Arabia model.
(()): Italian model.
< >: East European model

Adjustment Location : MAIN BOARD

[MAIN BOARD] (COMPONENT SIDE)

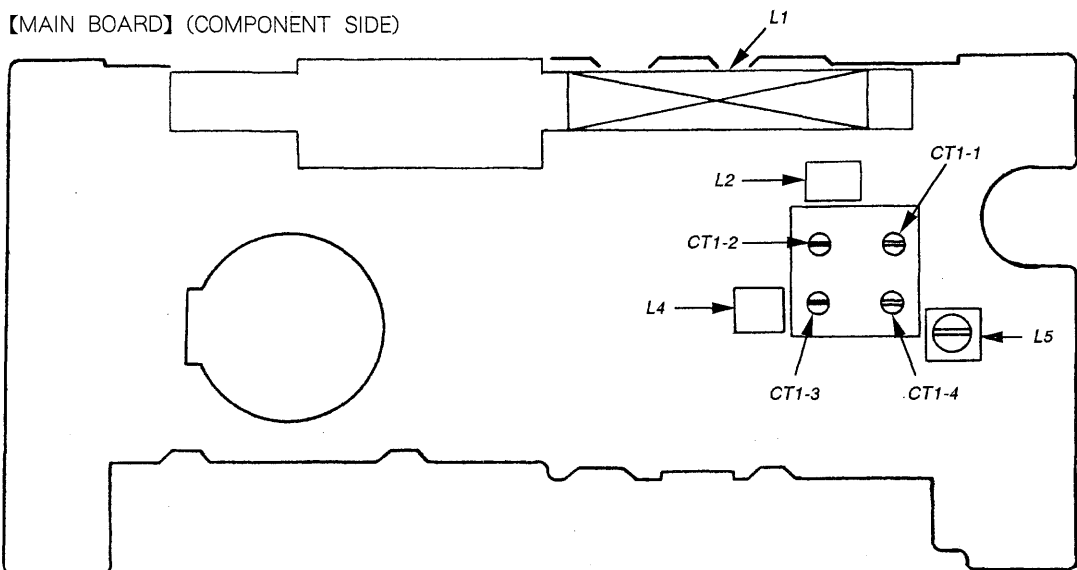

MEMO

A series of horizontal dotted lines for writing.

SECTION 3
DIAGRAMS

SEE ADDITIONAL
INFORMATION

3-1. PRINTED WIRING BOARD

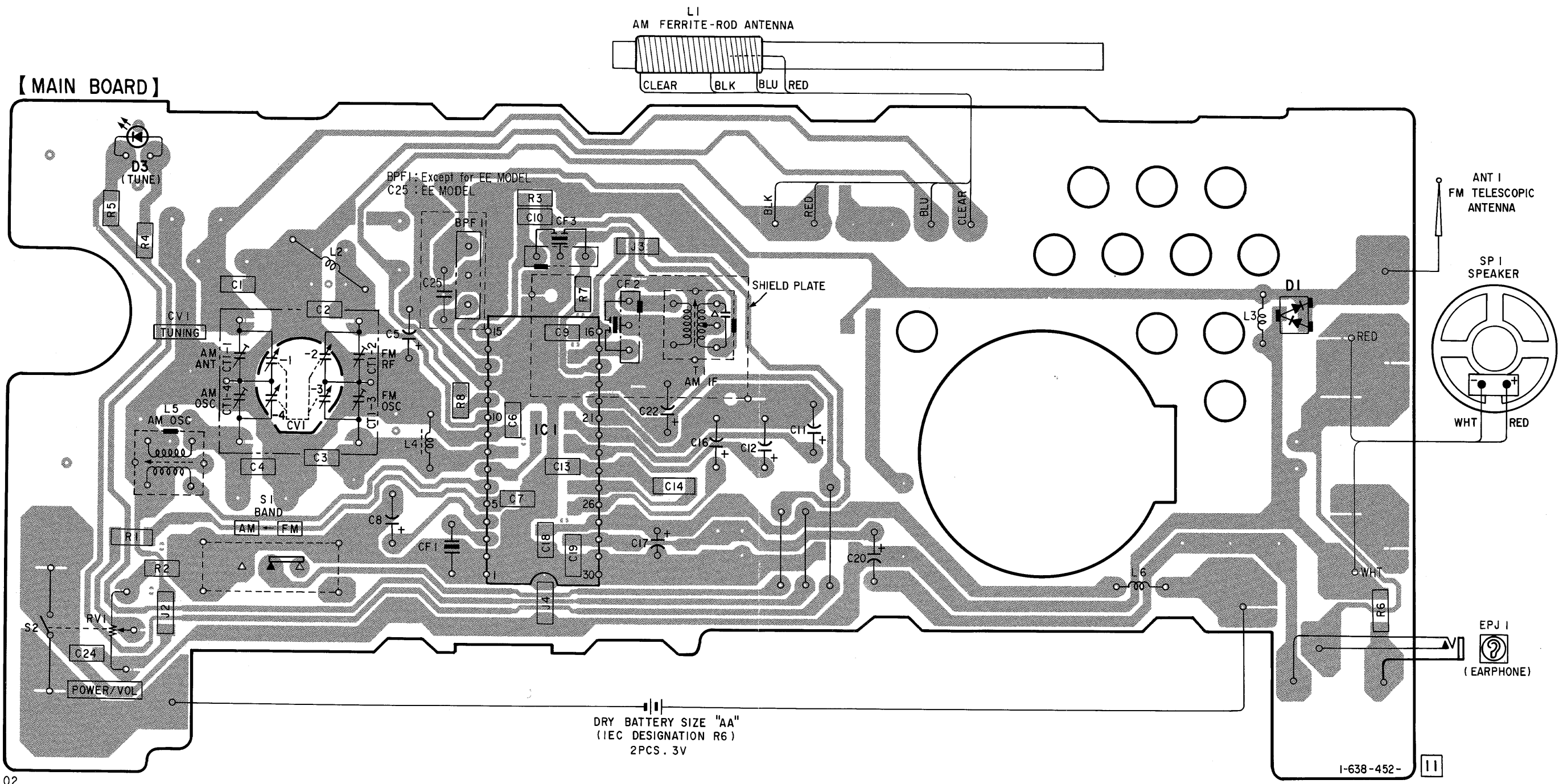

02

I-638-452-11

Note :

- ○ — : parts extracted from the component side.
- [] — : indicates side identified with part number.
- [] — : Pattern on the side which is seen.
- EE : East European Model

• SEMICONDUCTOR LEAD LAYOUT

TLR124

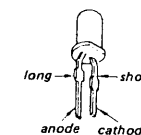

3-2. SCHEMATIC DIAGRAM

SEE ADDITIONAL INFORMATION

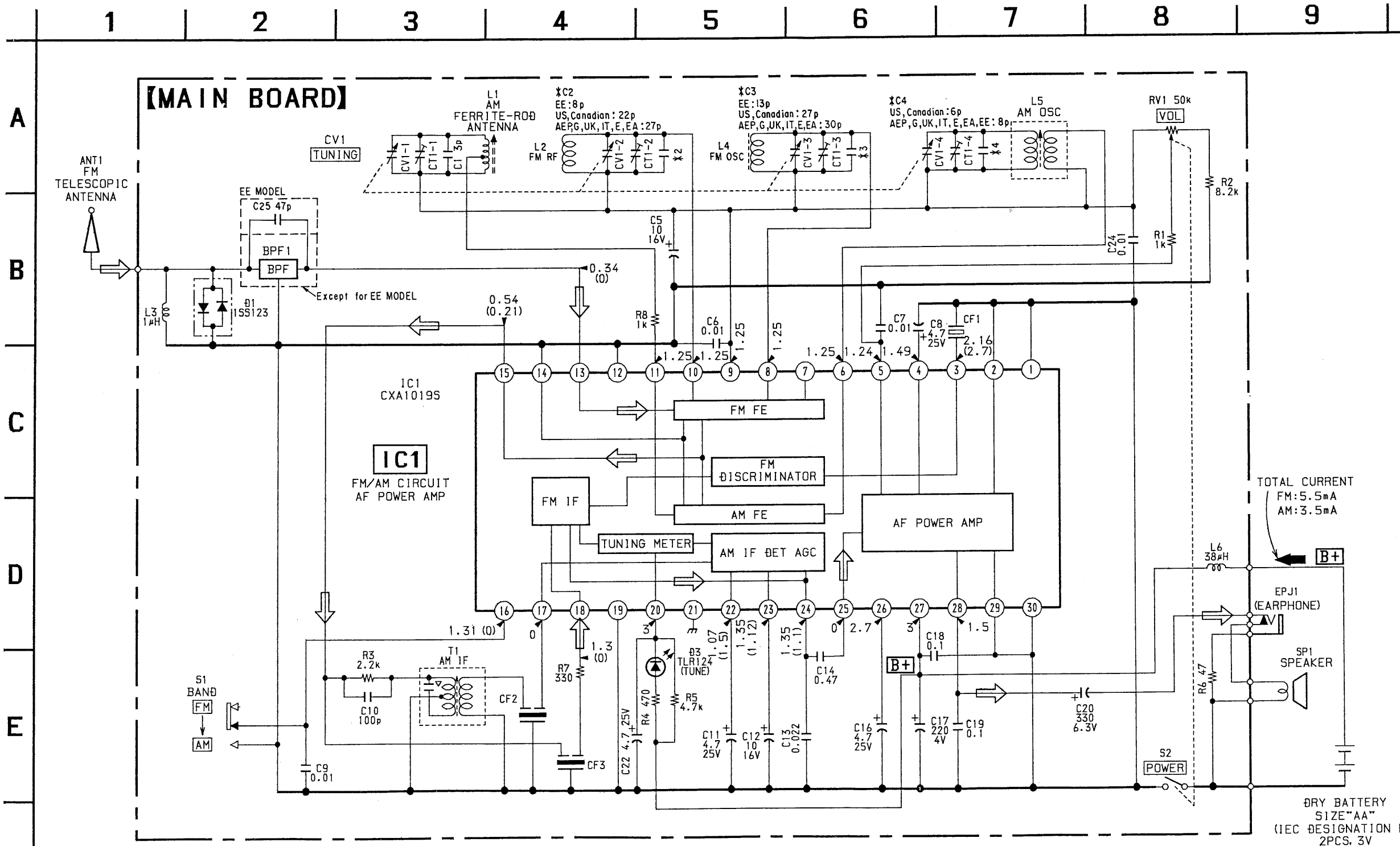

02

Note :

- All capacitors are in μF unless otherwise noted. $\text{pF} : \mu\mu\text{F}$
- 50WV or less are not indicated except for electrolytics and tantalums.
- All resistors are in Ω and $\frac{1}{4}\text{W}$ or less unless otherwise specified.
- Δ : internal component.
- **B+** : B+ Line
- IT : Italian Model
- EA : Saudi Arabia Model
- G : German Model
- EE : East European Model
- Total current is measured with power ON.
- Power voltage is dc 3V and fed with regulated dc power supply from battery terminal.
- Voltage are dc with respect to ground under no-signal conditions.
- no mark : FM
- () : AM
- Voltages are taken with a VOM (input impedance 10M Ω). Voltage variations may be noted due to normal production tolerances.
- Signal path.
- \Rightarrow : FM

DRY BATTERY
SIZE "AA"
(IEC DESIGNATION R6)
2PCS, 3V

SEE ADDITIONAL INFORMATION

**SECTION 4
EXPLODED VIEW**

NOTE:

- -XX, -X mean standardized parts, so they may have some differences from the original one.
- The construction parts of an assembled part are indicated with a collation number in the remark column.
- Color indication of Appearance Parts
Example:
KNOB, BALANCE (WHITE).... (RED)

- Items marked "*" are not stocked since they are seldom required for routine service. Some delay should be anticipated when ordering these items.

- The mechanical parts with no reference number in the exploded views are not supplied.
- IT : Italian Model
EA : Saudi Arabia Model
G : German Model
EE : East European Model
AE7: Spanish Model

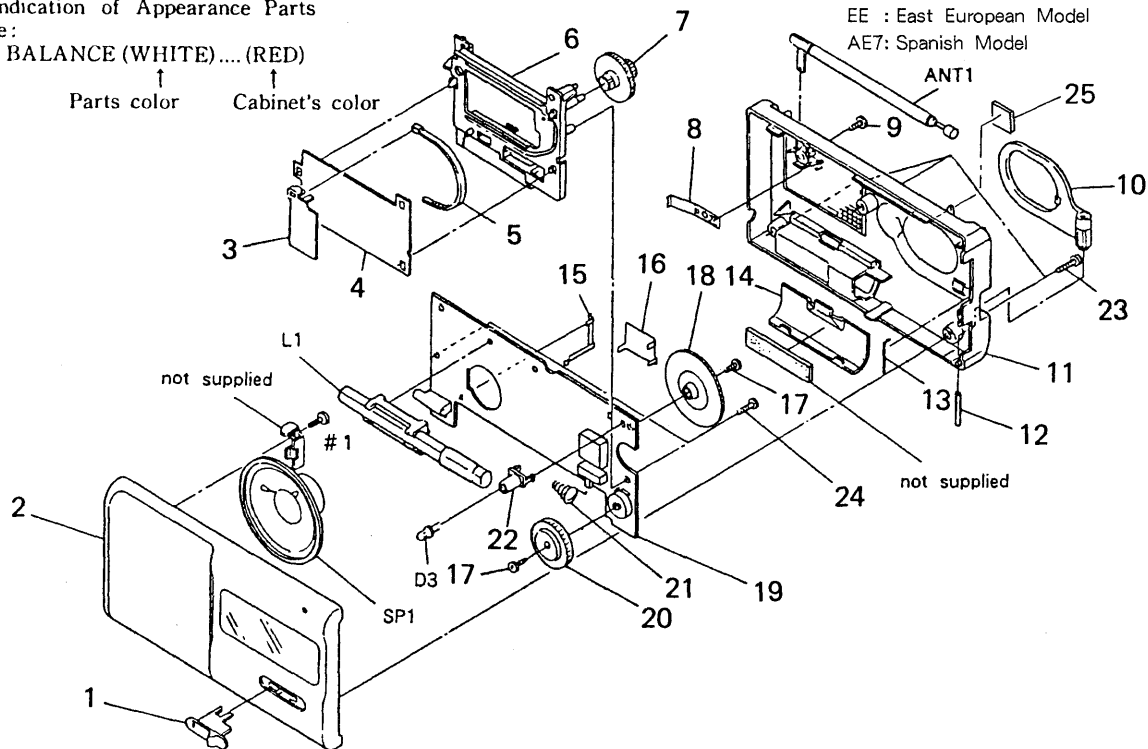

Ref. No.	Part No.	Description	Remark
1	3-369-174-01	KNOB (BAND) (BLK)	
1	3-369-174-11	KNOB (BAND) (WHT) (EXCEPT EA)	
1	3-369-174-21	KNOB (BAND) (RED) (AE7, UK)	
2	X-3363-152-1	CABINET (FRONT) ASSY (BLK) (AEP, UK, E, EA)	
2	X-3363-153-1	CABINET (FRONT) ASSY (BLK) (IT)	
2	X-3363-154-1	CABINET (FRONT) ASSY (WHT) (AEP, UK, E)	
2	X-3363-156-1	CABINET (FRONT) ASSY (RED) (AE7, UK)	
2	X-3363-157-1	CABINET (FRONT) ASSY (WHT) (IT)	
2	X-3363-158-1	CABINET (FRONT) ASSY (BLK) (US, Canadian)	
2	X-3363-737-1	CABINET (FRONT) ASSY (WHT) (US, Canadian)	
2	X-3367-359-1	CABINET (FRONT) ASSY (BLK) (EE)	
3	3-369-163-01	POINTER	
* 4	3-369-165-01	PLATE, BACK	
5	3-369-170-01	RACK	
* 6	3-369-185-01	CHASSIS	
7	3-369-172-01	KNOB (TUNE) (BLK)	
7	3-369-172-11	KNOB (TUNE) (WHT) (EXCEPT EA)	
7	3-369-172-21	KNOB (TUNE) (RED) (AE7, UK)	
* 8	3-369-166-01	PLATE (ANT), CONTACT	
9	3-370-476-01	SCREW (+B) (2X5), NYLOCK	
10	3-369-169-01	HANDLE (BLK) (EXCEPT EE)	
10	3-369-169-11	HANDLE (WHT) (EXCEPT EA)	
10	3-369-169-21	HANDLE (RED) (AE7, UK)	
10	3-369-169-41	HANDLE (BLK) (EE)	
11	3-369-187-01	CABINET (REAR) (BLK) (AEP, UK, IT, EE)	
11	3-369-187-11	CABINET (REAR) (WHT) (AEP, UK, IT)	
11	3-369-187-21	CABINET (REAR) (RED) (AE7, UK)	
11	3-369-187-41	CABINET (REAR) (BLK) (US, Canadian, E, EA)	
11	3-369-187-51	CABINET (REAR) (WHT) (US, Canadian, E)	

Ref. No.	Part No.	Description	Remark
12	3-372-368-01	PIN, PARALLEL	
13	3-372-123-01	SPRING (HANDLE)	
14	3-369-161-01	LID, BATTERY CASE (BLK)	
14	3-369-161-11	LID, BATTERY CASE (WHT) (EXCEPT EA)	
14	3-369-161-21	LID, BATTERY CASE (RED) (AE7, UK)	
15	3-369-157-01	PLATE, CONTACT BATTERY	
* 16	3-369-167-01	PLATE, SHIELD	
17	3-370-474-21	SCREW (NYLOCK +B 1.7x4)	
18	3-369-171-01	GEAR (TUNING CAPACITOR)	
* 19	A-3661-293-A	MAIN BOARD (CHIP). COMPLETE (AE7/UK/E)	
* 19	A-3661-326-A	MAIN BOARD (CHIP). COMPLETE (G, IT, EA)	
* 19	A-3661-445-A	MAIN BOARD (CHIP). COMPLETE (US, Canadian)	
* 19	A-3661-885-A	MAIN BOARD (CHIP), COMPLETE (EE)	
20	3-369-173-01	KNOB (VOL) (BLK)	
20	3-369-173-11	KNOB (VOL) (WHT) (EXCEPT EA)	
20	3-369-173-21	KNOB (VOL) (RED) (AE7, UK)	
21	3-369-164-01	SPRING, BATTERY	
* 22	3-369-162-01	HOLDER, LED	
23	7-685-135-19	SCREW +2.6x10 TYPE2 NO-SLIT	
24	3-371-765-21	SCREW +BTP 2X8	
25	3-372-369-01	CUSHION (REAR)	
ANT1	1-501-247-21	ANTENNA, TELESCOPIC	
D3	8-719-812-41	DIODE TLR124	
L1	1-402-566-11	ANTENNA, FERRITE-ROD (AM)	
SP1	1-544-517-11	SPEAKER	

SEE ADDITIONAL INFORMATION

SECTION 5 ELECTRICAL PARTS LIST

MAIN

NOTE:

- Due to standardization, replacements in the parts list may be different from the parts specified in the diagrams or the components used on the set.
- -XX, -X mean standardized parts, so they may have some difference from the original one.
- RESISTORS
All resistors are in ohms
METAL: Metal-film resistor
METAL OXIDE: Metal Oxide-film resistor
F: nonflammable

- Items marked "*" are not stocked since they are seldom required for routine service. Some delay should be anticipated when ordering these items.
- SEMICONDUCTORS
In each case, u: μ , for example:
uA.....: μ A....., uPA.....: μ PA.....
uPB.....: μ PB....., uPC.....: μ PC.....
uPD.....: μ PD.....
- CAPACITORS
uF: μ F
- COILS
uH: μ H

When indicating parts by reference number, please include the board name.

- IT : Italian Model
- EA : Saudi Arabia Model
- G : German Model
- EE : East European Model
- AE7: Spanish Model

Ref. No.	Part No.	Description	Remark
*	A-3661-293-A	MAIN BOARD (CHIP). COMPLETE	(AE7, UK, E)
*	A-3661-326-A	MAIN BOARD (CHIP). COMPLETE	(G, IT, EA)
*	A-3661-445-A	MAIN BOARD (CHIP). COMPLETE	(US, Canadian)
*	A-3661-885-A	MAIN BOARD (CHIP), COMPLETE	(EE)

< FILTER >			
BPF1	1-236-839-11	FILTER, BAND PASS	(Except for EE)
< CAPACITOR >			
C1	1-163-086-00	CERAMIC CHIP	3PF 50V
C2	1-163-091-00	CERAMIC CHIP	8PF 50V (EE)
C2	1-163-101-00	CERAMIC CHIP	22PF 5% 50V (US, Canadian)
C2	1-163-103-00	CERAMIC CHIP	27PF 5% 50V (AEP, G, UK, IT, E, EA)
C3	1-163-103-00	CERAMIC CHIP	27PF 5% 50V (US, Canadian)
C3	1-163-104-00	CERAMIC CHIP	30PF 5% 50V (AEP, G, UK, IT, E, EA)
C3	1-163-706-00	CERAMIC CHIP	13PF 5% 50V (EE)
C4	1-163-089-00	CERAMIC CHIP	6PF 5% 50V (US, Canadian)
C4	1-163-091-00	CERAMIC CHIP	8PF 50V (AEP, G, UK, IT, E, EA, EE)
C5	1-126-157-11	ELECT	10uF 20% 16V
C6	1-164-232-11	CERAMIC CHIP	0.01uF 50V
C7	1-163-031-11	CERAMIC CHIP	0.01uF 50V
C8	1-126-163-11	ELECT	4.7uF 20% 50V
C9	1-163-031-11	CERAMIC CHIP	0.01uF 50V
C10	1-163-117-00	CERAMIC CHIP	100PF 5% 50V
C11	1-126-163-11	ELECT	4.7uF 20% 50V
C12	1-126-157-11	ELECT	10uF 20% 16V
C13	1-163-037-11	CERAMIC CHIP	0.022uF 10% 25V
C14	1-162-637-11	CERAMIC CHIP	0.47uF 16V

Ref. No.	Part No.	Description	Remark
C16	1-126-163-11	ELECT	4.7uF 20% 50V
C17	1-124-434-11	ELECT	220uF 20% 4V
C18	1-163-077-00	CERAMIC CHIP	0.1uF 10% 25V
C19	1-163-077-00	CERAMIC CHIP	0.1uF 10% 25V
C20	1-128-057-11	ELECT	330uF 20% 6.3V
C22	1-126-163-11	ELECT	4.7uF 20% 50V
C24	1-163-031-11	CERAMIC CHIP	0.01uF 50V
C25	1-101-881-61	CERAMIC	47PF 10% 50V (EE)
< FILTER >			
CF1	1-567-097-61	FILTER, CERAMIC	
CF2	1-577-072-11	FILTER, CERAMIC	
CF3	1-567-097-61	FILTER, CERAMIC	
< VARIABLE CAPACITOR >			
CV1	1-151-641-11	CAP, VARIABLE (TUNING)	(US, Canadian)
CV1	1-151-658-11	CAP, VARIABLE (TUNING)	(AEP, G, UK, IT, E, EA)
CV1	1-151-659-11	CAP, VARIABLE (TUNING)	(EE)
< DIODE >			
D1	8-719-800-76	DIODE	1SS226
D3	8-719-812-41	DIODE	TLR124
< JACK >			
EPJ1	1-563-836-21	JACK (EARPHONE)	
< IC >			
IC1	8-752-035-29	IC	CXA1019S
< JACK >			
J2	1-216-296-00	METAL CHIP	0 5% 1/8W
J3	1-216-296-00	METAL CHIP	0 5% 1/8W
J4	1-216-296-00	METAL CHIP	0 5% 1/8W

SEE ADDITIONAL
INFORMATION

MAIN

Ref. No.	Part No.	Description	Remark
< COIL >			
L1	1-402-566-11	ANTENNA, FERRITE-ROD (MW) (AEP, G, UK, IT, E, EA, EE)	
L1	1-402-566-21	ANTENNA, FERRITE-ROD (MW) (US, Canadian)	
L2	1-406-922-11	COIL, AIR-CORE (EE)	
* L2	1-422-320-11	COIL, AIR-CORE (AEP, G, UK, IT, E, EA)	
* L2	1-428-287-11	COIL, AIR-CORE (US, Canadian)	
L3	1-410-316-11	INDUCTOR 1uH	
* L4	1-422-294-11	COIL, AIR-CORE (AE7, UK, E)	
* L4	1-422-342-11	COIL, AIR-CORE (US, Canadian)	
L4	1-428-241-11	COIL, AIR-CORE (EE)	
L4	1-460-018-11	COIL (WITH CORE) (G, IT, EA)	
L5	1-406-028-00	COIL, OSC (MW)	
L6	1-410-294-11	INDUCTOR, MICRO 38uH	
< RESISTOR >			
R1	1-216-198-00	METAL CHIP 1K 5% 1/8W	
R2	1-216-071-00	METAL CHIP 8.2K 5% 1/10W	
R3	1-216-057-00	METAL CHIP 2.2K 5% 1/10W	
R4	1-216-041-00	METAL CHIP 470 5% 1/10W	
R5	1-216-065-00	METAL CHIP 4.7K 5% 1/10W	
R6	1-216-166-00	METAL GLAZE 47 5% 1/8W	
R7	1-216-037-00	METAL CHIP 330 5% 1/10W	
R8	1-216-049-00	METAL CHIP 1K 5% 1/10W	
< VARIABLE RESISTOR >			
RV1	1-241-555-11	RES, VAR, CARBON 50K (POWER/VOL)	
< SWITCH >			
S1	1-552-370-00	SWITCH, SLIDE (BAND)	
< TRANSFORMER >			
T1	1-404-341-00	TRANSFORMER, 1F	

Ref. No.	Part No.	Description	Remark
MISCELLANEOUS *****			
ANT1	1-501-247-21	ANTENNA, TELESCOPIC	
SP1	1-544-517-11	SPEAKER	

ACCESSORY & PACKING MATERIAL *****			
*	3-369-733-01	INDIVIDUAL CARTON (US, Canadian, E, EA)	
*	3-369-733-21	INDIVIDUAL CARTON (AEP, G, UK, IT, EE)	
*	3-370-050-01	CUSHION, CORRUGATED FIBERBOARD	
	3-703-264-11	LABEL (B), SERIAL NO	
	3-753-405-11	MANUAL, INSTRUCTION (ENGLISH/GERMAN /FRENCH/ ITALIAN/DUTCH)	
	3-753-405-41	MANUAL, INSTRUCTION (ARABIC/SWEDISH /PORTUGUESE) (AE7, UK, EA)	
	3-753-405-61	MANUAL, INSTRUCTION (ENGLISH/POLISH /HUNGARIAN/CZECH/RUSSIAN) (EE)	

ICF-380

SONY[®] SERVICE MANUAL

US Model
Canadian Model
AEP Model
UK Model
E Model

SUPPLEMENT-1

File this Supplement with the Service Manual.

**Subject :The contents are partly changed by
the difference of manufactory.
("MADE IN JAPAN" AE7 Model only)**

● AE7 : Spanish

– MODEL IDENTIFICATION –

– Specification –

Note : The differences between "MADE IN JAPAN" and "MADE IN MALAYSIA" can be judged by specification label.

SONY[®]
DC : 3V \dashv R6 (SIZE AA) \times 2
BATT OR EQUIV
MADE IN JAPAN

SONY[®]
DC : 3V \dashv R6 (SIZE AA) \times 2
BATT OR EQUIV
MADE IN MALAYSIA

MADE IN MALAYSIA

● CHANGED PARTS LIST (Service Manual Page 9, 10, 11)

Ref. No.	Former Parts Description (Part No.)	Part No.	New Parts Description	Remark
12	3-703-358-08 PIN, PARALLEL (DIA.2 \times 20)	3-372-368-01	PIN, PARALLEL	Changed
17	3-370-474-01	3-370-474-21	SCREW (NYLOCK + B 1.7 \times 4)	Changed
23	3-376-001-01 SCREW (+ PTP)(2.6 \times 10)	7-685-135-19 (Ref. No. : # 1)	SCREW + 2.6 \times 10 TYPE2 NO-SLIT	Changed
SP1	1-544-517-21	1-544-517-11	SPEAKER	Changed
C4	1-163-093-00 CERAMIC CHIP 10PF 5% 50V (AEP, UK, IT, E, EA)	1-163-091-00	CERAMIC CHIP 8PF 5% 50V (AEP, UK, IT, E, EA)	Changed
C7	1-164-232-11 CERAMIC CHIP 0.01 μ F 50V	1-163-031-11	CERAMIC CHIP 0.01 μ F 50V	Changed
C9	1-164-232-11 CERAMIC CHIP 0.01 μ F 50V	1-163-031-11	CERAMIC CHIP 0.01 μ F 50V	Changed
C17	1-124-635-00 ELECT 220 μ F 20% 4V	1-124-434-11	ELECT 220 μ F 20% 4V	Changed
C20	1-124-442-00 ELECT 330 μ F 20% 6.3V	1-128-057-11	ELECT 330 μ F 20% 6.3V	Changed

**SECTION 2
ADJUSTMENTS**

MADE IN JAPAN

(AE7 MODEL ONLY)

FM SECTION

BAND SWITCH : FM

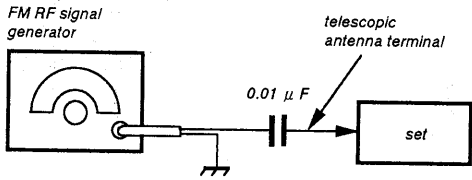

400Hz, 30% FM modulation
frequency deviation \pm 22.5kHz
Output level: as low as possible

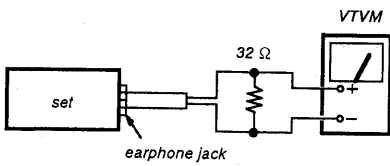

- Repeat the procedures in each adjustment several times, and the frequency coverage and tracking adjustments should be finally done by the trimmer capacitors.

FM FREQUENCY COVERAGE ADJUSTMENT	
Adjust for a maximum reading on VTVM.	
L3	87.35MHz
CT1-3	108.5MHz

FM TRACKING ADJUSTMENT	
Adjust for a maximum reading on VTVM.	
L2	87.35MHz
CT1-2	108.5MHz

AM SECTION

BAND SWITCH : AM

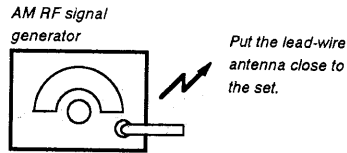

400Hz, 30%
AM modulation
Output level: as low as possible

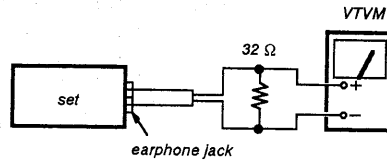

- Repeat the procedures in each adjustment several times, and the frequency coverage and tracking adjustments should be finally done by the trimmer capacitors.

AM FREQUENCY COVERAGE ADJUSTMENT	
Adjust for a maximum reading on VTVM.	
L4	520kHz
CT1-4	1,650kHz

AM TRACKING ADJUSTMENT	
Adjust for a maximum reading on VTVM.	
L1	620kHz
CT1-1	1,400kHz

Adjustment Location :

[MAIN BOARD] (COMPONENT SIDE)

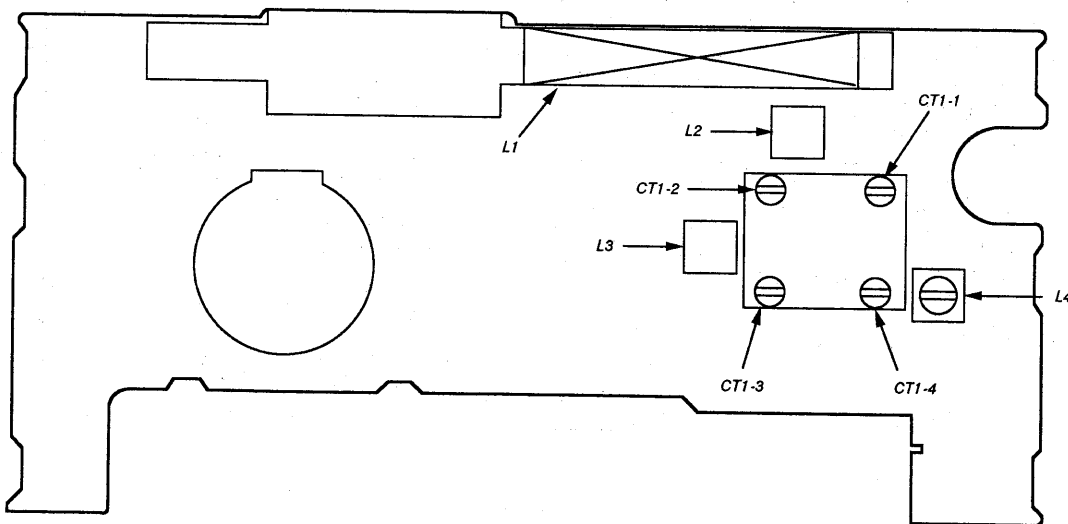

SECTION 3
DIAGRAMS

MADE IN JAPAN (AE7 MODEL ONLY)

3.1 PRINTED WIRING BOARD

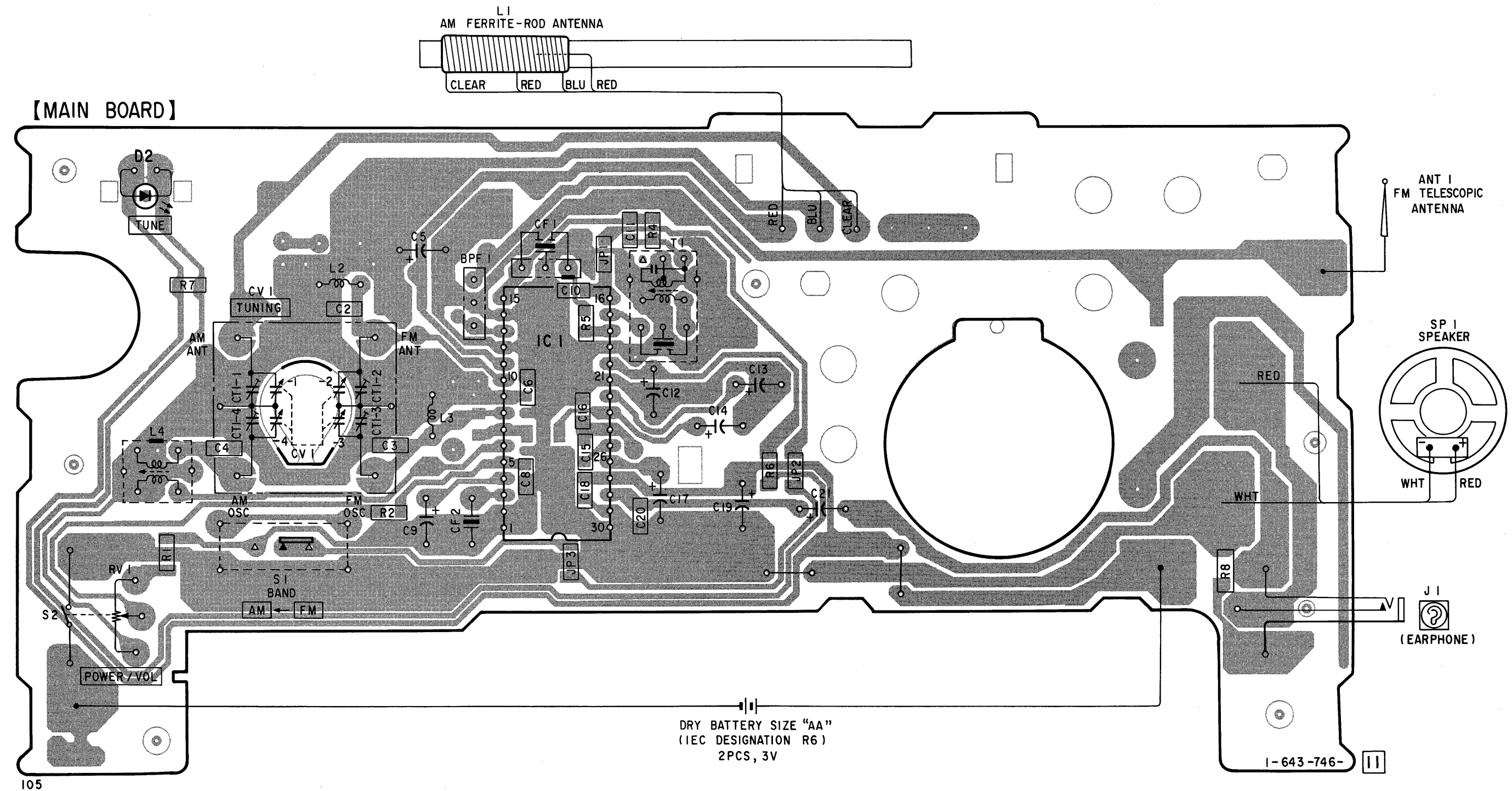

105

- Note:
- ○ — : parts extracted from the component side.
 - [] — : indicates side identified with part number.
 - [] — : Pattern on the side which is seen.

• SEMICONDUCTOR LEAD LAYOUT

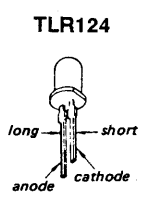

3.2 SCHEMATIC DIAGRAM

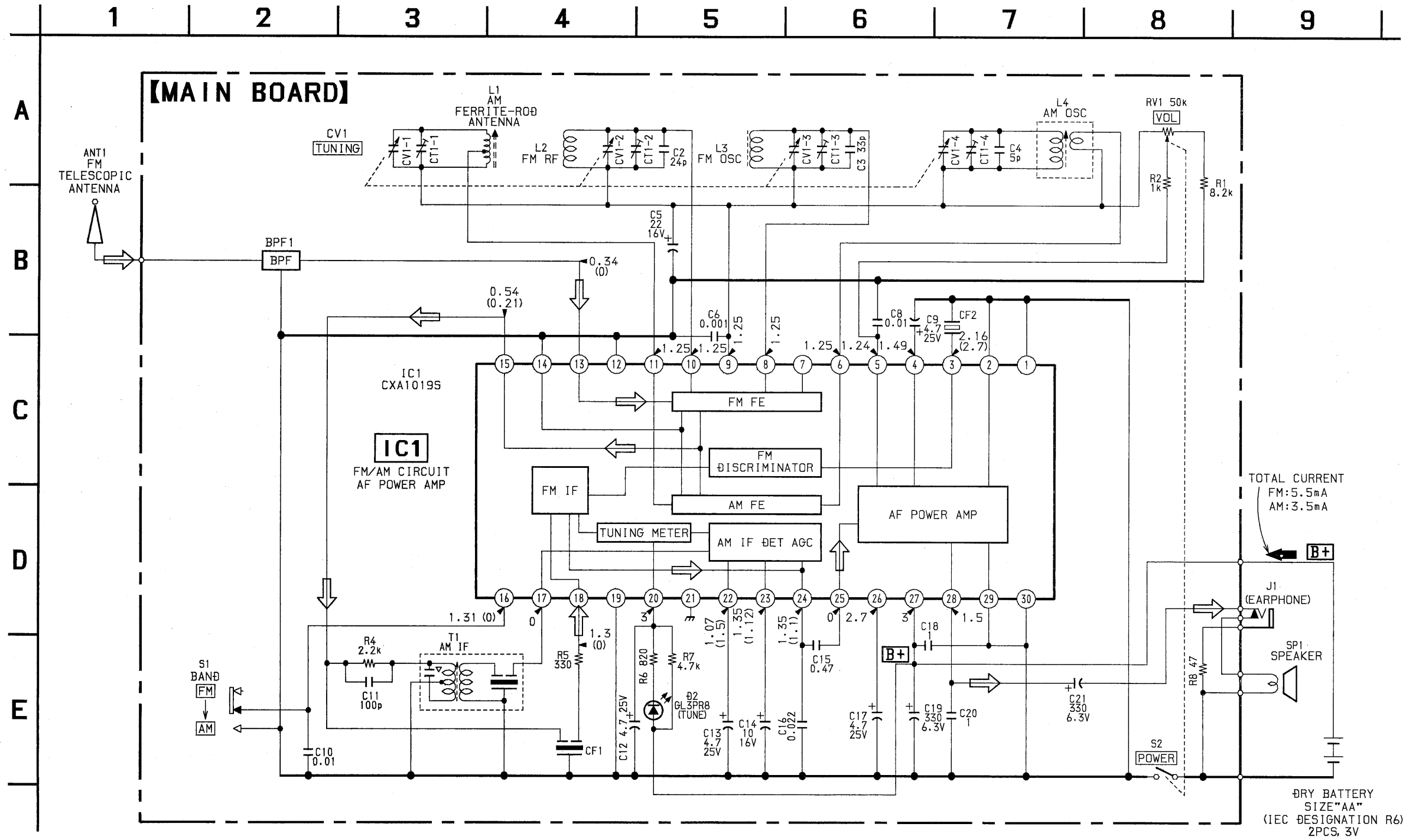

TOTAL CURRENT
FM: 5.5mA
AM: 3.5mA

DRY BATTERY
SIZE "AA"
(IEC DESIGNATION R6)
2PCS, 3V

Note:

- All capacitors are in μF unless otherwise noted. pF: $\mu \mu F$
50WV or less are not indicated except for electrolytics and tantalums.
- All resistors are in Ω and $\frac{1}{4}W$ or less unless otherwise specified.
- Δ : internal component.
- **B+**: B+ Line
- Total current is measured with power ON.
- Power voltage is dc 3V and fed with regulated dc power supply from battery terminal.
- Voltage are dc with respect to ground under no-signal conditions.
no mark: FM
(): AM
- Voltages are taken with a VOM (Input impedance 10M Ω).
Voltage variations may be noted due to normal production tolerances.
- Signal path.
 \Rightarrow : FM

MADE IN JAPAN

(AE7 MODEL ONLY)

MAIN

NOTE:

- Due to standardization, replacements in the parts list may be different from the parts specified in the diagrams or the components used on the set.
- -XX, -X mean standardized parts, so they may have some difference from the original one.
- RESISTORS
All resistors are in ohms
METAL : Metal-film resistor
METAL OXIDE : Metal oxide-film resistor
F : nonflammable

- Items marked " * " are not stocked since they are seldom required for routine service. Some delay should be anticipated when ordering these items.

● SEMICONDUCTORS

In each case, u : μ , for example :

uA..... : μ A....., uPA..... : μ PA.....

uPB..... : μ PB....., uPC..... : μ PC.....

uPD..... : μ PD.....

● CAPACITORS

uF : μ F

● COILS

uH : μ H

When indicating parts by reference number, please include the board.

Ref.No.	Part No.	Description	Remark
*	A-3679-444-A	MAIN BOARD COMPLETE *****	
		< FILTER >	
BPF1	1-239-061-11	FILTER, BAND PASS	
		< CAPACITOR >	
C2	1-163-102-00	CERAMIC CHIP 24PF	5% 50V
C3	1-163-715-11	CERAMIC CHIP 33PF	5% 50V
C4	1-163-088-00	CERAMIC CHIP 5PF	0.25PF 50V
C5	1-124-134-00	ELECT 22MF	20% 16V
C6	1-163-141-00	CERAMIC CHIP 1000PF	5% 50V
C8	1-163-031-11	CERAMIC CHIP 0.01MF	50V
C9	1-126-163-00	ELECT 4.7MF	20% 50V
C10	1-164-232-11	CERAMIC CHIP 0.01MF	10% 50V
C11	1-163-117-00	CERAMIC CHIP 100PF	5% 50V
C12	1-126-163-11	ELECT 4.7MF	20% 50V
C13	1-126-163-11	ELECT 4.7MF	20% 50V
C14	1-126-157-11	ELECT 10MF	20% 16V
C15	1-164-005-11	CERAMIC CHIP 0.47MF	25V
C16	1-163-037-11	CERAMIC CHIP 0.022MF	10% 25V
C17	1-126-163-11	ELECT 4.7MF	20% 50V
C18	1-164-346-11	CERAMIC CHIP 1MF	16V
C19	1-124-442-00	ELECT 330MF	20% 6.3V
C20	1-164-346-11	CERAMIC CHIP 1MF	16V
C21	1-124-442-00	ELECT 330MF	20% 6.3V
		< FILTER >	
CF1	1-567-097-61	FILTER, CERAMIC	
CF2	1-567-097-61	FILTER, CERAMIC	
		< VARIABLE CAPACITOR >	
CV1	1-151-703-11	CAP, VARIABLE (TUNING)	

Ref.No.	Part No.	Description	Remark
		< DIODE >	
D2	8-719-812-41	DIODE TLR124 (TUNE)	
		< IC >	
IC1	8-752-035-29	IC CXA1019S	
		< JACK >	
J1	1-691-917-11	JACK, EP (EARPHONE)	
		< JUMPER RESISTER >	
JP1	1-216-295-00	METAL CHIP 0	5% 1/10W
JP2	1-216-296-00	METAL CHIP 0	5% 1/8W
JP3	1-216-296-00	METAL CHIP 0	5% 1/8W
		< COIL >	
L1	1-501-554-11	ANTENNA, FERRITE-ROD (AM)	
* L2	1-422-320-11	COIL, AIR-CORE	
* L3	1-422-341-11	COIL, AIR-CORE	
L4	1-406-492-11	COIL (OSC)	
		< RESISTER >	
R1	1-216-220-00	METAL CHIP 8.2K	5% 1/8W
R2	1-216-049-00	METAL CHIP 1K	5% 1/10W
R4	1-216-057-00	METAL CHIP 2.2K	5% 1/10W
R5	1-216-037-00	METAL CHIP 330	5% 1/10W
R6	1-216-196-00	METAL CHIP 820	5% 1/8W
R7	1-216-065-00	METAL CHIP 4.7K	5% 1/10W
R8	1-216-166-00	METAL CHIP 47	5% 1/8W
		< VARIABLE RESISTER >	
RV1	1-241-900-11	RES, VAR, CARBON 50K (POWER/VOL)	

Ref.No. Part No. Description Remark

< SWITCH >

S1 1-553-015-00 SWITCH, SLIDE (BAND)

< TRANSFORMER >

T1 1-239-321-11 TRANSFORMER, IF

MISCELLANEOUS

ANT1 1-501-247-21 ANTENNA, TELESCOPIC
SP1 1-504-147-11 SPEAKER (5.7CM)

ACCESSORY & PACKING MATERIAL

* 3-383-006-01 INDIVIDUAL CARTON
3-755-679-11 MANUAL, INSTRUCTION (ENGLISH, SPANISH)

HARDWARE LIST

#1 7-685-135-19 SCREW +P 2.6X10 TYPE2 NON-SLIT

