

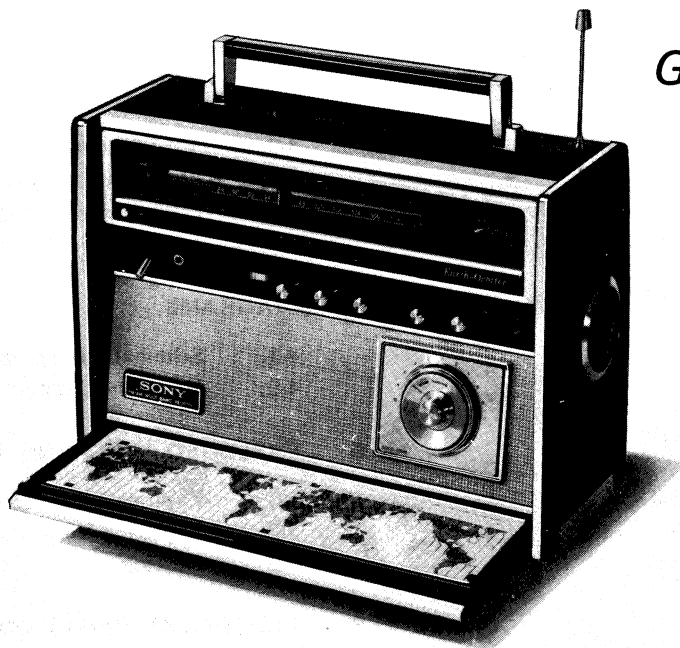

Set using ISO screws

CRF-5090

*GEP Model
General Export Model*



SPECIFICATIONS

Circuit System:	13-transistor 10-diode superheterodyne 7-transistors for auxiliary circuit	Selectivity at ± 10 kHz off-resonance:	35 dB at 1,400 kHz
Frequency Coverage:	AIR 108 – 136 MHz (2.78 – 2.2 m) FM 87.5 – 108 MHz (3.42 – 2.78 m) LW 150 – 400 kHz (2000 – 750 m) MW 530 – 1,605 kHz (566 – 187 m) SW1 1.6 – 3.5 MHz (187 – 86 m) SW2 3.5 – 9.0 MHz (86 – 33 m) SW3 9.0 – 14.0 MHz (33 – 21 m) SW4 14 – 21 MHz (21 – 14 m) SW5 21 – 26 MHz (14 – 11 m)	Power Output at 10 % distortion: maximum:	1.8 W 2.7 W
Intermediate Frequency:	FM/AIR 10.7 MHz LW/MW/SW 455 kHz	Current Drain at zero signal: maximum:	FM 40 mA, MW 35 mA 320 mA
Antenna System:	FM/AIR telescopic antenna or external antenna (impedance 75 Ω) LW/MW built-in ferrite bar antenna or external antenna (high impedance) SW telescopic antenna or external antenna (impedance 75 Ω)	Power Requirement:	DC eight "D" size flashlight batteries 12 volts or car battery by using SONY car battery cord DCC-2AW AC house current 100 V, 120 V, 220 V or 240 VAC; 50/60 Hz
Sensitivity at 50 mW output, S/N 6 dB:	AIR 0.9 μ V (–1 dB) FM 0.7 μ V (–3 dB) LW 63 μ V/m (36 dB/m) MW 24 μ V/m (27 dB/m) SW1 1.2 μ V (1 dB) SW2 1 μ V (0 dB) SW3 1 μ V (0 dB) SW4 1.2 μ V (1 dB) SW5 1.3 μ V (2 dB)	Speaker:	10 cm x 15 cm (4" x 6"), 8 Ω
		Dimensions:	340 mm (W) x 230 mm (H) x 160 mm (D) (13 $\frac{3}{8}$ " x 9 $\frac{1}{16}$ " x 6 $\frac{5}{16}$ ")
		Weight:	6.6 kg (14 lb 9 oz) overall with batteries

SONY®

SERVICE MANUAL

TABLE OF CONTENTS

<u>Section</u>	<u>Title</u>	<u>Page</u>	<u>Section</u>	<u>Title</u>	<u>Page</u>
	Specifications	1			
1. OUTLINE			3-2.	AM I-f Alignment	9
1-1.	Block Diagram	3	3-3.	Bfo Osc Coil Adjustment.	9
1-2.	External View	3	3-4.	Frequency Coverage and Tracking Adjustment.	10
2. DISASSEMBLY AND REASSEMBLY			4. DIAGRAMS		
2-1.	Front Panel Removal	4	4-1.	Schematic Diagram.	13
2-2.	Chassis Removal	4	4-2.	Mounting Diagram	15
2-3.	FM Front End Removal	5	5. EXPLODED VIEW AND PACKING		
2-4.	FM Front End Reassembly.	5	5-1.	Exploded View (1).	17
2-5.	Dial Scale Reassembly	5	5-2.	Exploded View (2).	19
2-6.	Circuit Board Removal.	6	5-3.	Packing	21
2-7.	Dial Cord Stringing.	6	6. ELECTRICAL PARTS LIST.		22
3. CIRCUIT ADJUSTMENTS					
3-1.	FM I-f Alignment	8			

Hardware Nomenclature

P – Pan Head Screw		SC – Set Screw	
PS – Pan Head Screw with Spring Washer		E – Retaining Ring (E Washer)	
K – Flat Countersunk Head Screw		W – Washer	
B – Binding Head Screw		SW – Spring Washer	
RK – Oval Countersunk Head Screw		LW – Lock Washer	
T – Truss Head Screw		N – Nut	
R – Round Head Screw			
F – Flat Fillister Head Screw			

– Example –

When ordering replacement parts, you should use PART NUMBER listed on the Parts List or shown in the EXPLODED VIEW. The reference number should not be used for ordering purposes.

**SECTION 1
OUTLINE**

1-1. BLOCK DIAGRAM

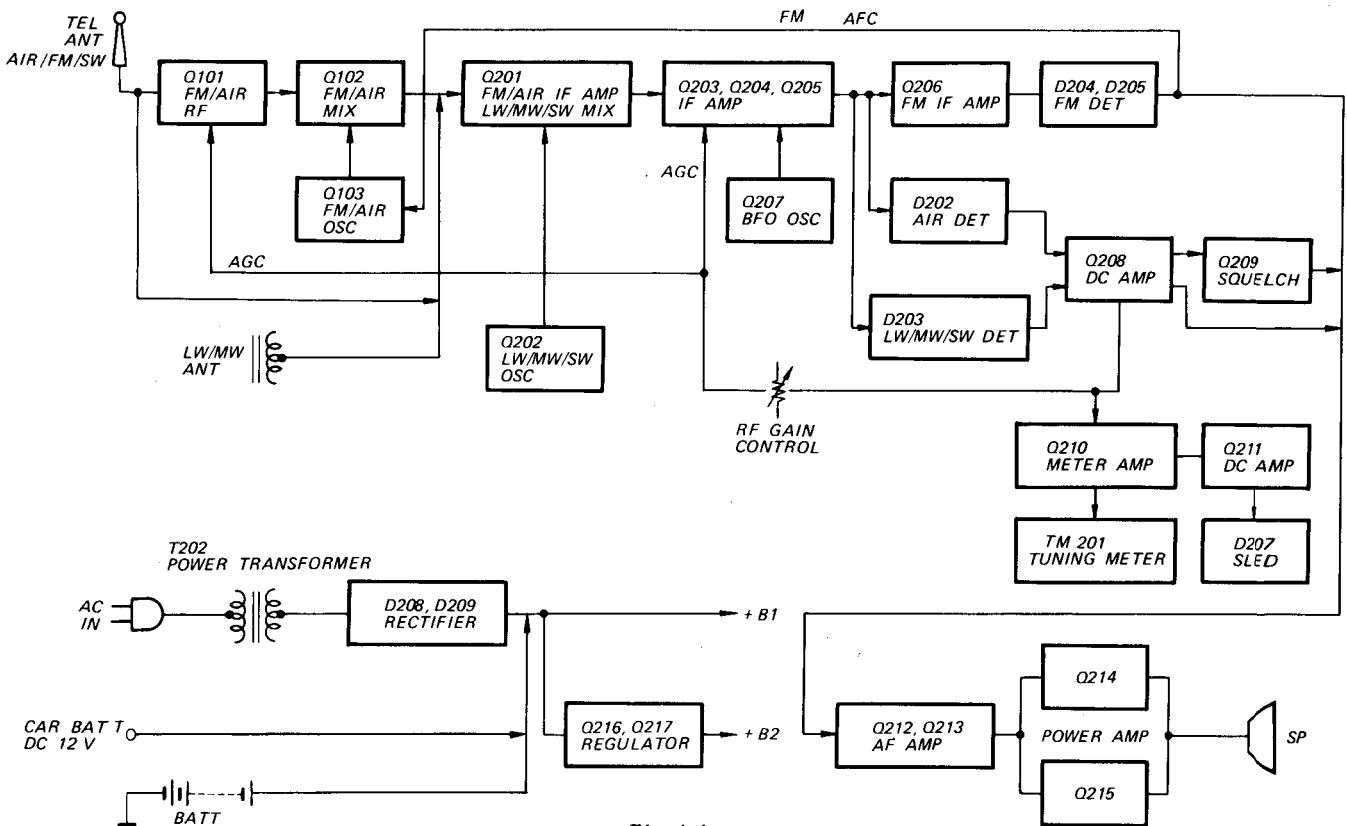
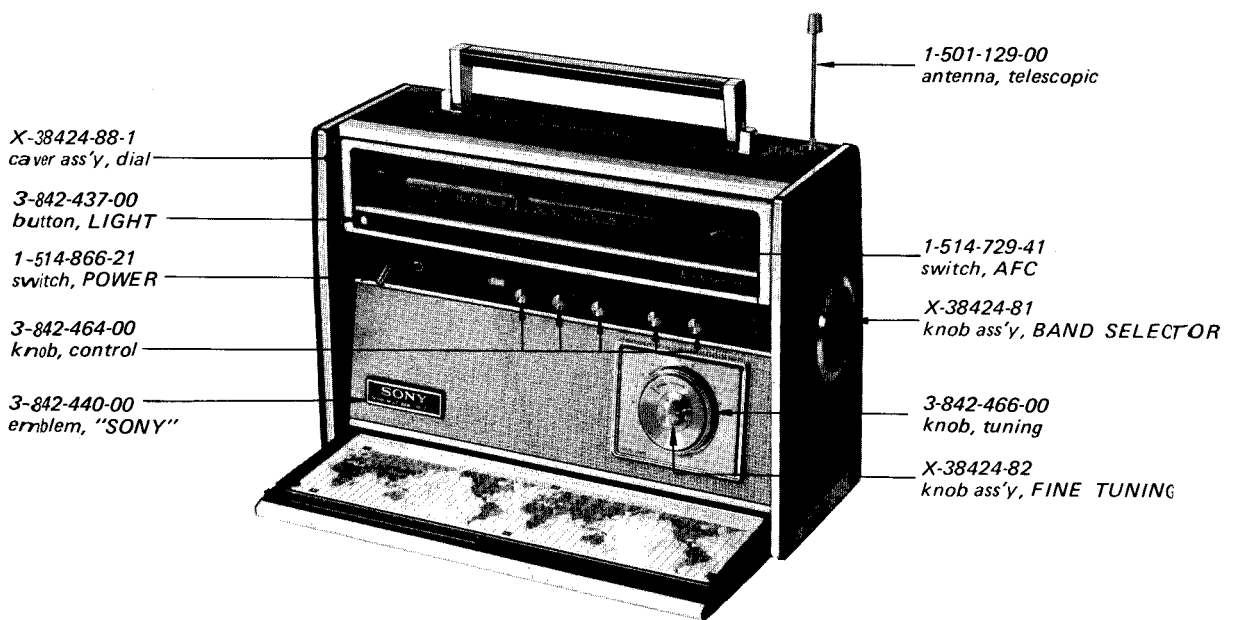

Fig. 1-1.

1-2. EXTERNAL VIEW



CRF-5090

SECTION 2

DISASSEMBLY AND REASSEMBLY

2-1. FRONT PANEL REMOVAL

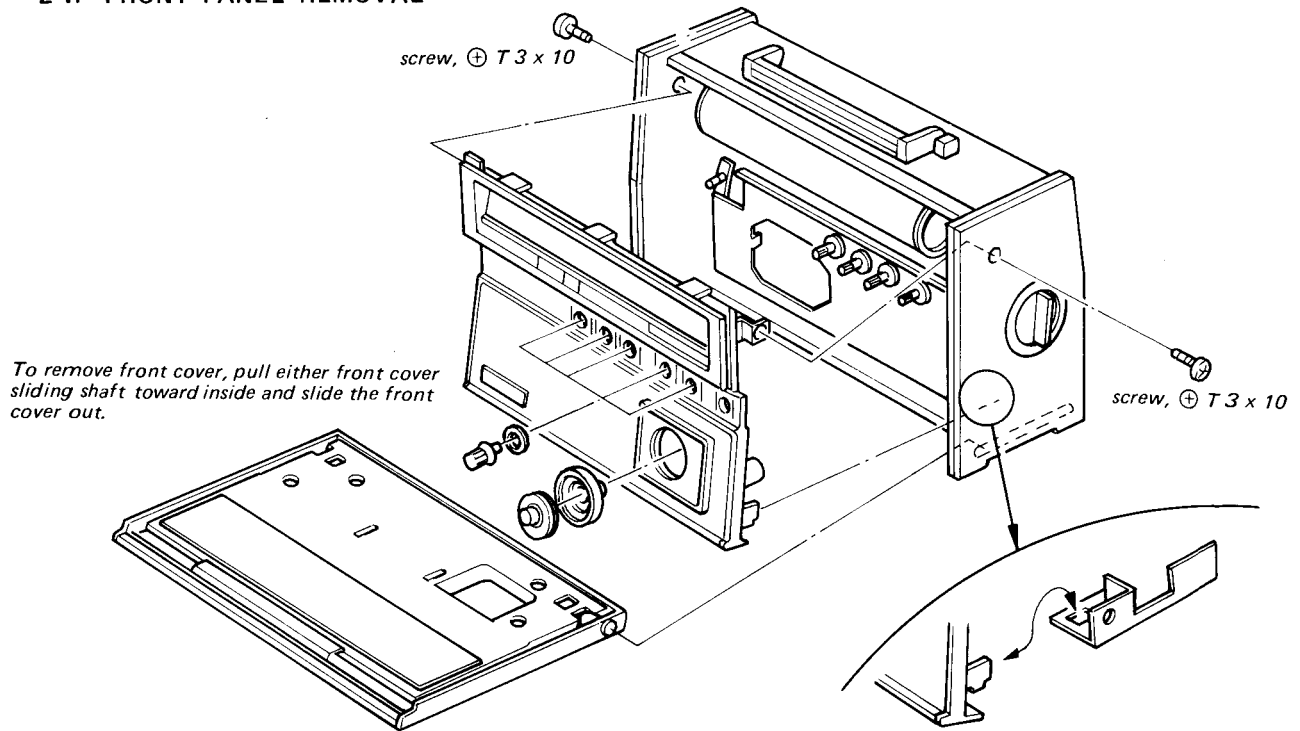

2-2. CHASSIS REMOVAL

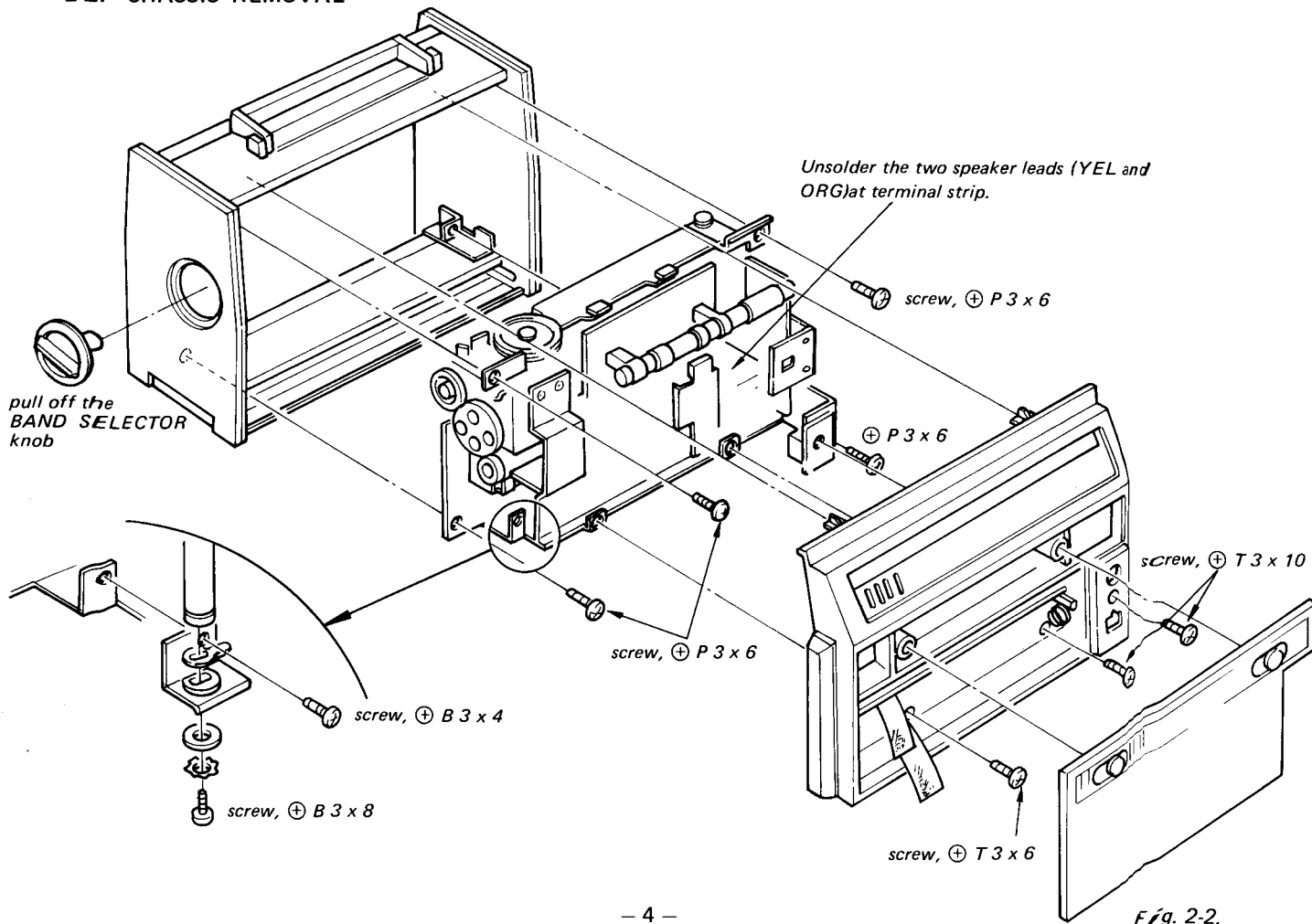

2-3. FM FRONT END REMOVAL

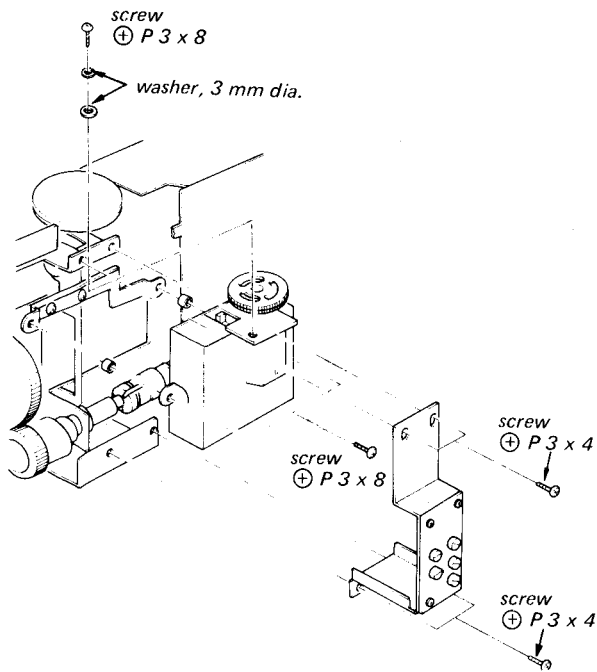

Fig. 2-3.

2-4. FM FRONT END REASSEMBLY

1. Rotate the dial drum fully clockwise and the double gear ass'y fully counterclockwise.
2. Attach the FM/AIR selector lever A on the FM/AIR selector switch.
3. Set the FM front end with three screws. See Fig. 2-3. above.

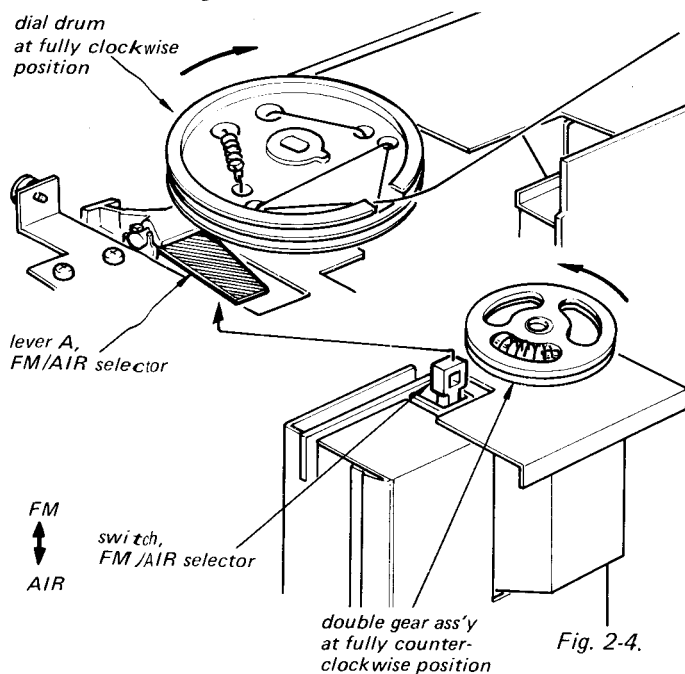

Fig. 2-4.

2-5. DIAL SCALE REASSEMBLY

1. Rotate the BAND SELECTOR knob fully clockwise.
2. Be sure that FM/AIR selector lever B is pushed upwards and that FM/AIR selector switch is pushed downwards. If not, remove the BAND SELECTOR knob and gear B and readjust the shaft of gear A by rotating idler.
3. Set the dial drum so that it shows AIR band and that the tip of the pointer is on the line of AIR band as shown in Fig. 2-6.

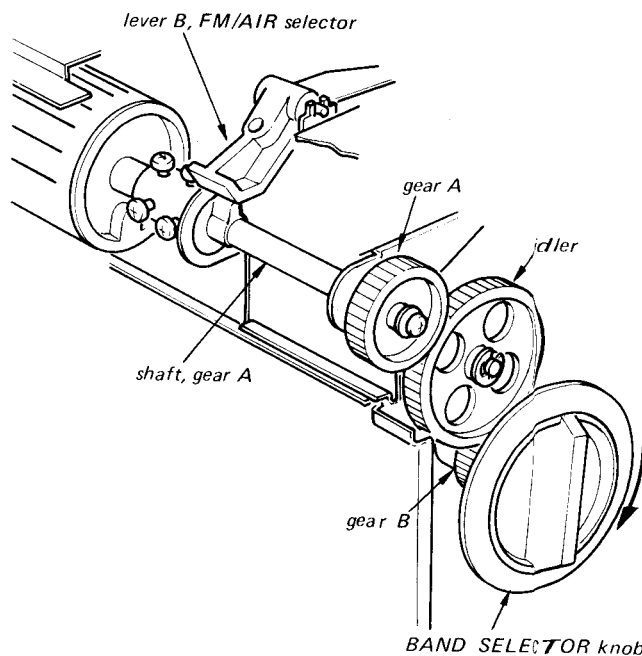

Fig. 2-5.

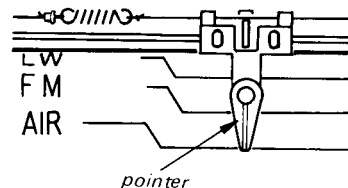

Fig. 2-6.

CRF-5090

2-6. CIRCUIT BOARD REMOVAL

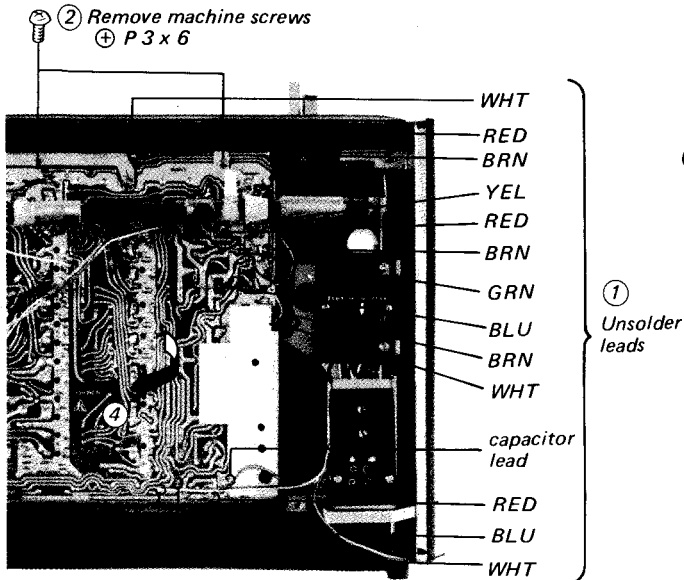
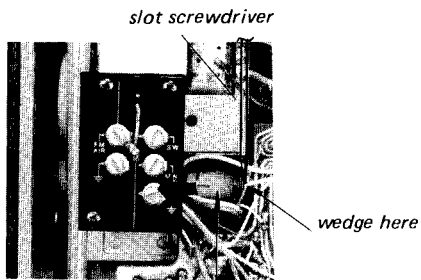

Fig. 2-7.



- 3-842-488
③ Remove connector A from band selector switch shaft by wedging.

Fig. 2-8.

2-7. DIAL CORD STRINGING

Dial Drum Driving Cord

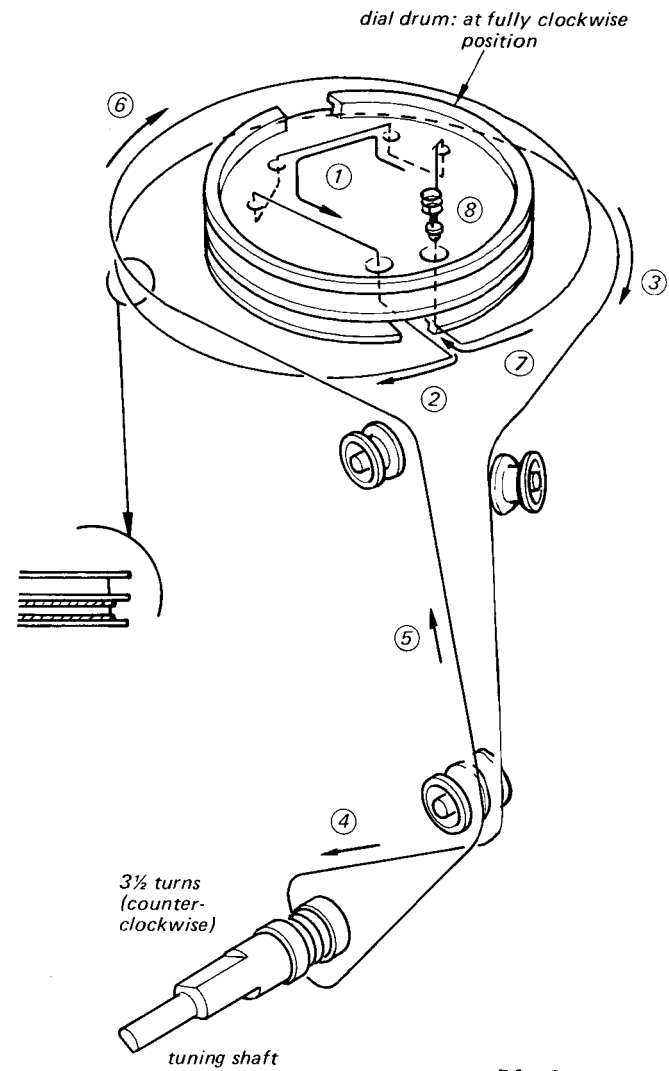
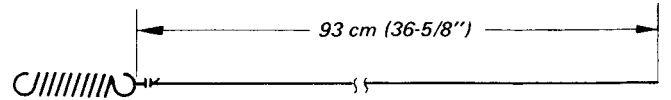

Fig. 2-9.

Pointer Driving Cord

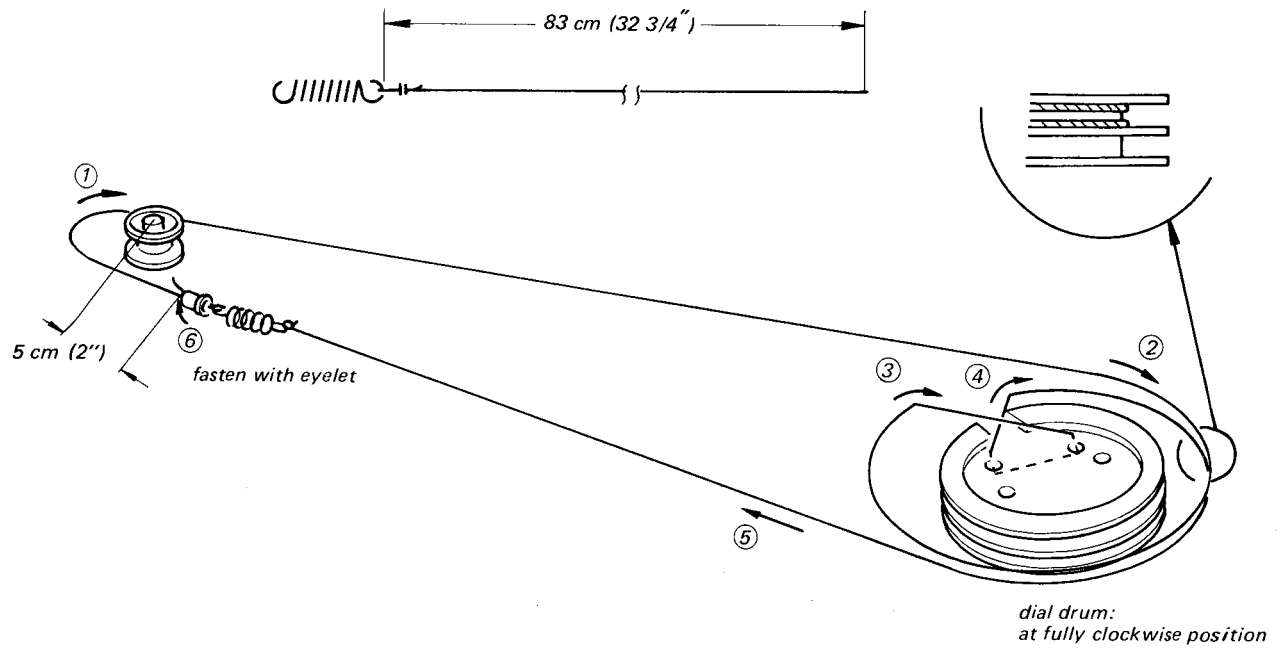

Fig. 2-10.

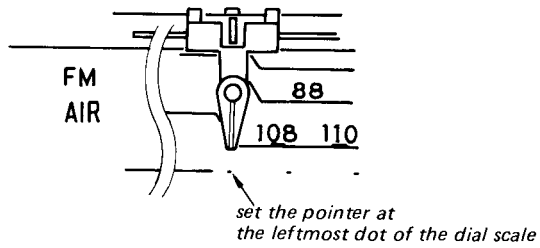

Fig. 2-11.

CRF-5090

**SECTION 3
CIRCUIT ADJUSTMENTS**

Test Equipment/Tools Required:

- Rf signal generator (for FM and AM)
- Loop antenna
- VTVM
- 8 Ω resistor
- 0.01 μF ceramic capacitor
- Screwdriver for alignment

Modulation:

- FM 400 Hz, ±22.5 kHz frequency-modulated signal
- AM 400 Hz, 30% amplitude-modulated signal

Preparation

VTVM Connection:

To EARPHONE jack with 8 Ω load resistor in parallel

VOLUME Control Setting: Mechanical mid position

TONE Control Setting: Mechanical mid position

AFC Switch: OFF

BFO Control Setting: OFF

RF Gain Control Setting: NORMAL

SQUELCH Control Setting: Fully counterclockwise position

3-1. FM I-F ALIGNMENT

Setup is shown in Fig. 3-1.

Set the BAND SELECTOR to FM.

Connect the rf signal generator to the FM/AIR ext ant terminals after detaching antenna lug as shown in Fig. 3-2.

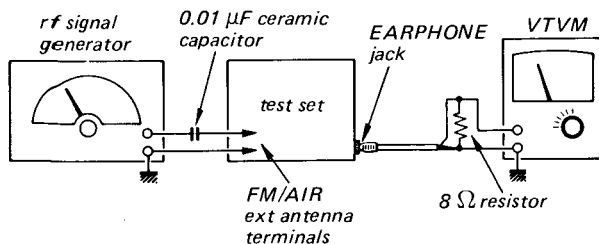

Fig. 3-1. FM/AIR i-f alignment, frequency coverage and tracking adjustment setup

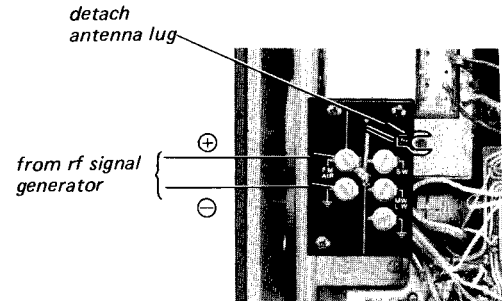

Fig. 3-2. Rf signal generator coupling

Rf Signal Generator Frequency	Rf Signal Modulation	Adjust	Remarks
10.7 MHz	400 Hz, 30% AM modulation	IFT F-4 See Fig. 3-6.	Adjust for minimum meter reading ^(*1) .
10.7 MHz	400 Hz, ±22.5 kHz FM modulation	IFT F-1 IFT F-2 ^(*2) IFT F-3 See Fig. 3-4 and Fig. 3-6.	Set the tuning knob at the best signal position. Adjust for maximum meter reading.

Note:*1. Minimum output will be observed at both extremes of the discriminator. The real null point will be obtained in the middle of the core thread length and maximum output will be obtained at both sides of the true null point. Slowly and carefully turn the core to obtain minimum output.

*2. IFT F-2 is unable to adjust from rear part of the set. Remove the front panel and adjust IFT F-2 from front part. (See Fig. 3-4).

3-2. AM I-F ALIGNMENT

AM i-f alignment can be eliminated except when necessary. The ceramic filter CFT is factory preset and i-f transformer IFT A1 is shielded by shield case. The intermediate frequency of the set is characterized by the ceramic filter because a ceramic filter has a peculiar vibrating frequency which depends on its size.

Preparation:

- POWER switch : ON
- BAND SELECTOR : MW
- BFO switch : OFF
- Rf Signal Generator Coupling:
Loop antenna (See Fig. 3-3)
- Modulation:
400 Hz 30% amplitude-modulated signal

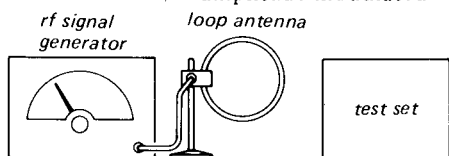

Fig. 3-3. AM i-f alignment and bfo osc coil adjustment setup

Modulate the rf signal with 400 Hz AM modulation. Vary the rf signal around 455 kHz to find i-f frequency of the set. The dial of the rf signal generator shows i-f frequency of the set when the output power of the speaker becomes maximum. If the peak of the output power is not found around 455 kHz, adjust the ceramic filter cores after removing front panel and dial drum as shown in Fig. 3-4.

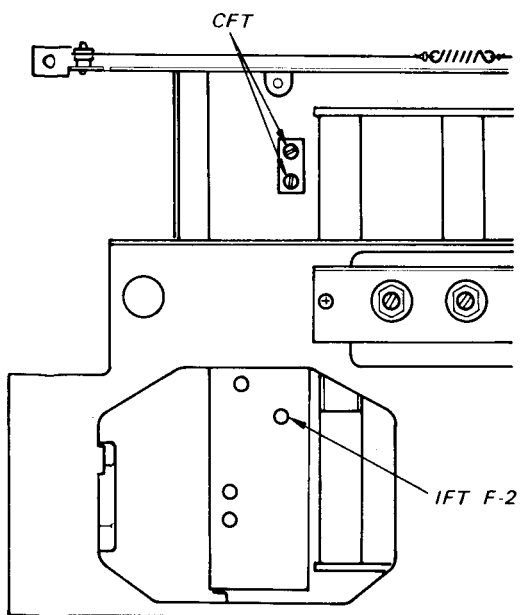

Fig. 3-4. Adjustment locations

3-3. BFO OSC COIL ADJUSTMENT

Preparation:

- POWER switch: ON
- BAND SELECTOR: MW
- BFO switch: ON
- BFO Control Setting:

Mechanical mid position as shown in Fig. 3-5.
Rf Signal Generator Coupling: Loop antenna
Setup: See Fig. 3-3.

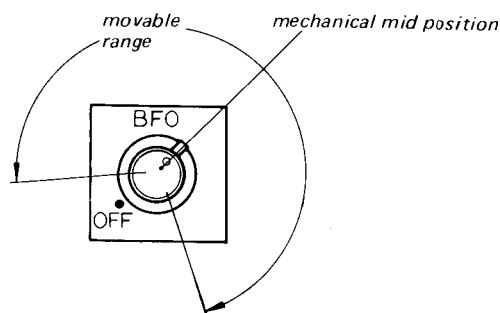

Fig. 3-5. BFO control setting

Rf Signal Generator Frequency	Adjust	Remarks
455 kHz unmodulated signal (*)	BFO osc coil L220 See Fig. 3-6.	Adjust for zero beating.

Note: (*) Tune the rf signal generator frequency to the i-f frequency of the set which is found in AM I-F ALIGNMENT.

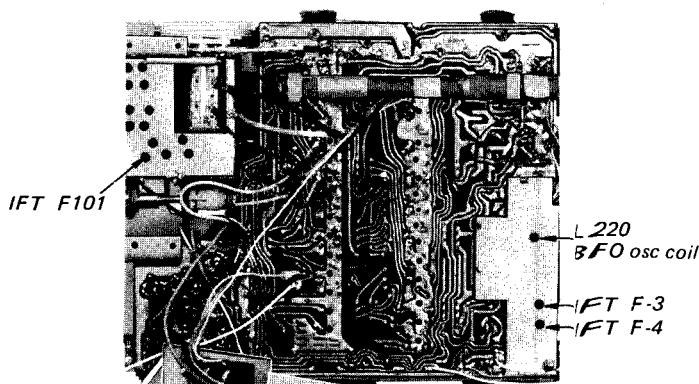

Fig. 3-6. Adjustment locations

CRF-5090

3-4. FREQUENCY COVERAGE AND TRACKING ADJUSTMENT

Setup: FM/AIR See Fig. 3-1.

LW/MW See Fig. 3-7.

SW1 - 5 See Fig. 3-8.

Note: Fully telescope the telescopic antenna.

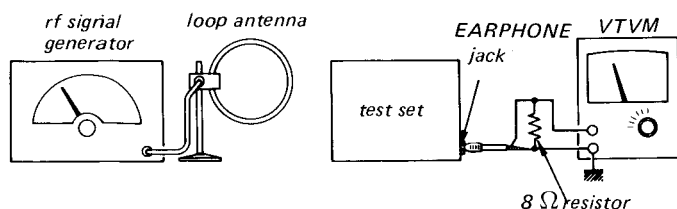

Fig. 3-7. LW/MW frequency coverage and tracking adjustment setup

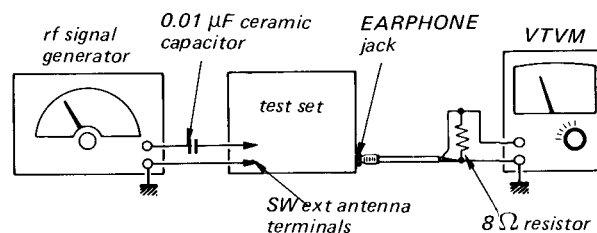

Fig. 3-8. SW1-5 frequency coverage and tracking adjustment setup

Note: In West Germany the FM frequency coverage should be within the range between 87.5 MHz and 108 MHz. Make the frequency coverage by adjusting osc coil L106 and osc trimmer CT105 with the intended frequency signal from the rf signal generator.

Adjustment	Rf Signal Generator Coupling	Rf Signal Generator Frequency	Receiver Pointer Setting	Adjust	Remarks
FM Frequency Coverage	To FM/AIR ext ant terminal by detaching ant lug (See Fig. 3-2)	86.5 MHz	Fully left	FM osc coil L106	BAND SELECTOR : FM Adjust for maximum meter reading.
		109.5 MHz	Fully right	FM osc trimmer CT105	
FM Tracking		86.5 MHz	Tune in 86.5 MHz signal	FM ant coil L101 FM rf coil L103	
		109.5 MHz	Tune in 109.5-MHZ signal	FM ant trimmer CT101 FM rf trimmer CT103	
AIR Frequency Coverage	- ditto -	107 MHz	Fully left	AIR osc coil L107	BAND SELECTOR : AIR Adjust for maximum meter reading.
		138 MHz	Fully right	AIR osc trimmer CT106	
AIR Tracking		107 MHz	Tune in 107 MHz signal	AIR ant coil L102 AIR rf coil L104	
		137.5 MHz	Tune in 137.5-MHz signal	AIR ant trimmer CT102 AIR rf trimmer CT104	
MW Frequency Coverage	Loop antenna (See Fig. 3-7)	520 kHz	Fully left	MW osc coil L202	BAND SELECTOR : MW Adjust for maximum meter reading.
		1,680 kHz	Fully right	MW osc trimmer CT202	

CRF-5090 CRF-5090

Adjustment	Rf Signal Generator Coupling	Rf Signal Generator Frequency	Receiver Pointer Setting	Adjust	Remarks
MW Tracking	Loop antenna	620 kHz	Tune in 620 kHz signal	Position of MW ant coil L210	BAND SELECTOR : MW Adjust for maximum meter reading
		1,400 kHz	Tune in 1,400-kHz signal	MW ant trimmer CT209	
LW Frequency Coverage	Loop antenna	145 kHz	Fully left	LW osc coil L201	BAND SELECTOR : LW Adjust for maximum meter reading.
		410 kHz	Fully right	LW osc trimmer CT201	
LW Tracking		160 kHz	Tune in 160 kHz signal	Position of LW ant coil L208	
		360 kHz	Tune in 360 kHz signal	LW ant trimmer CT208	
SW1 Frequency Coverage	To SW ext ant terminal (see Fig. 3-8)	1.55 MHz	Fully left	SW1 osc coil L203	BAND SELECTOR : SW1 Adjust for maximum meter reading.
		3.6 MHz	Fully right	SW1 osc trimmer CT203	
SW1 Tracking		1.55 MHz	Tune in 1.55 MHz signal	SW1 ant coil L211	
		3.6 MHz	Tune in 3.6 MHz signal	SW1 ant trimmer CT210	
SW2 Frequency Coverage	- ditto -	3.4 MHz	Fully left	SW2 osc coil L204	BAND SELECTOR : SW2 Adjust for maximum meter reading.
		9.2 MHz	Fully right	SW2 osc trimmer CT204	
SW2 Tracking		3.4 MHz	Tune in 3.4 MHz signal	SW2 ant coil L212	
		9.2 MHz	Tune in 9.2 MHz signal	SW2 ant trimmer CT211	
SW3 Frequency Coverage	- ditto -	8.9 MHz	Fully left	SW3 osc coil L205	BAND SELECTOR : SW3 Adjust for maximum meter reading.
		14.3 MHz	Fully right	SW3 osc trimmer CT205	
SW3 Tracking		8.9 MHz	Tune in 8.9 kHz signal	SW3 antcoil L213	
		14.3 MHz	Tune in 14.3 kHz signal	SW3 ant trimmer CT212	

Adjustment	Rf Signal Generator Coupling	Rf Signal Generator Frequency	Receiver Pointer Setting	Adjust	Remarks
SW4 Frequency Coverage	- ditto -	13.8 MHz	Fully left	SW4 osc coil L206	BAND SELECTOR : SW4 Adjust for maximum meter reading.
		21.4 MHz	Fully right	SW4 osc trimmer CT206	
SW4 Tracking		13.8 MHz	Tune in 13.8 MHz signal	SW4 ant coil L214	
		21.4 MHz	Tune in 21.4 MHz signal	SW4 ant trimmer CT213	
SW5 Frequency Coverage	- ditto -	20.7 MHz	Fully left	SW5 ant coil L207	BAND SELECTOR : SW5 Adjust for maximum meter reading.
		27.MHz	Fully right	SW5 osc trimmer CT207	
SW5 Tracking		20.7 MHz	Tune in 20.7 MHz signal	SW5 ant coil L215	
		27 MHz	Tune in 27 MHz signal	SW5 ant trimmer CT214	

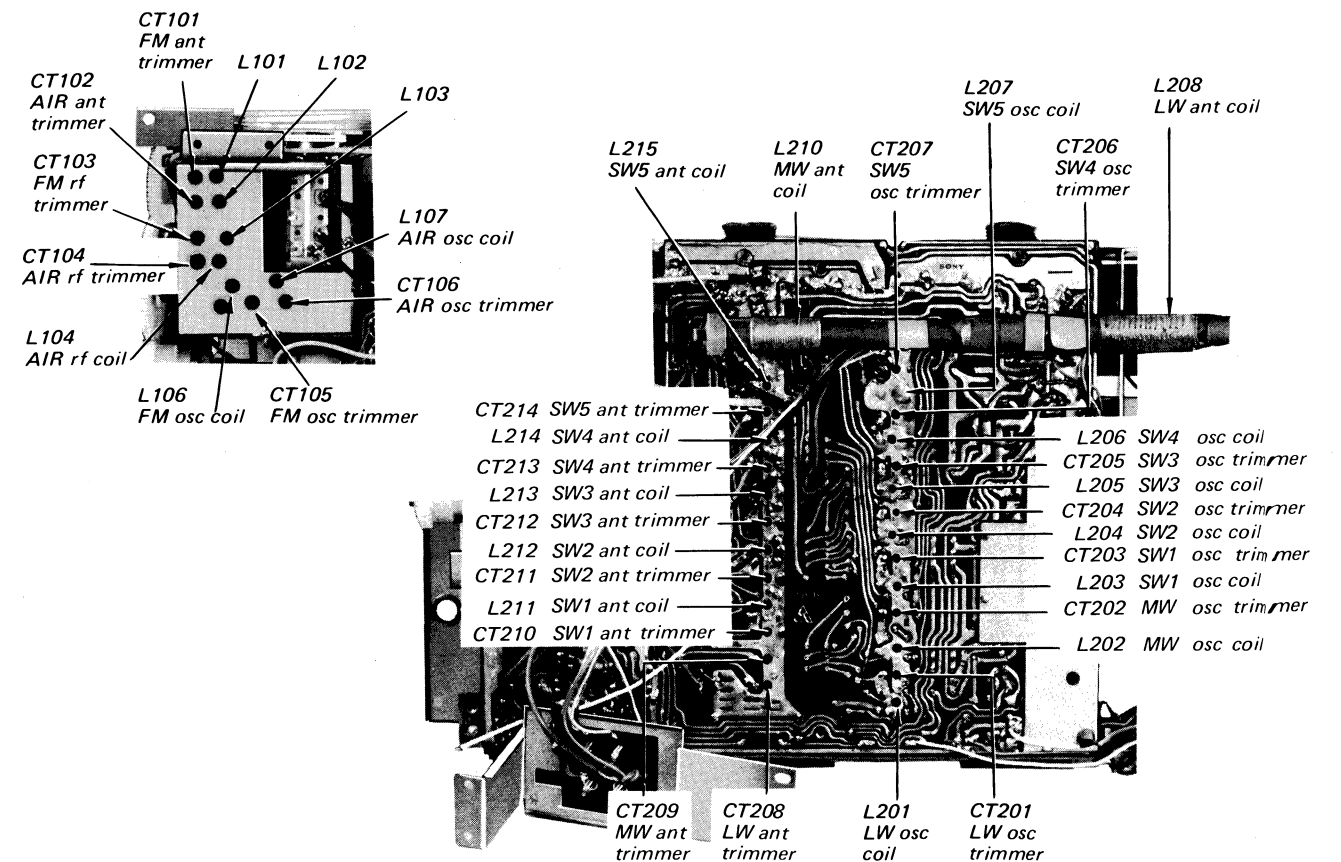
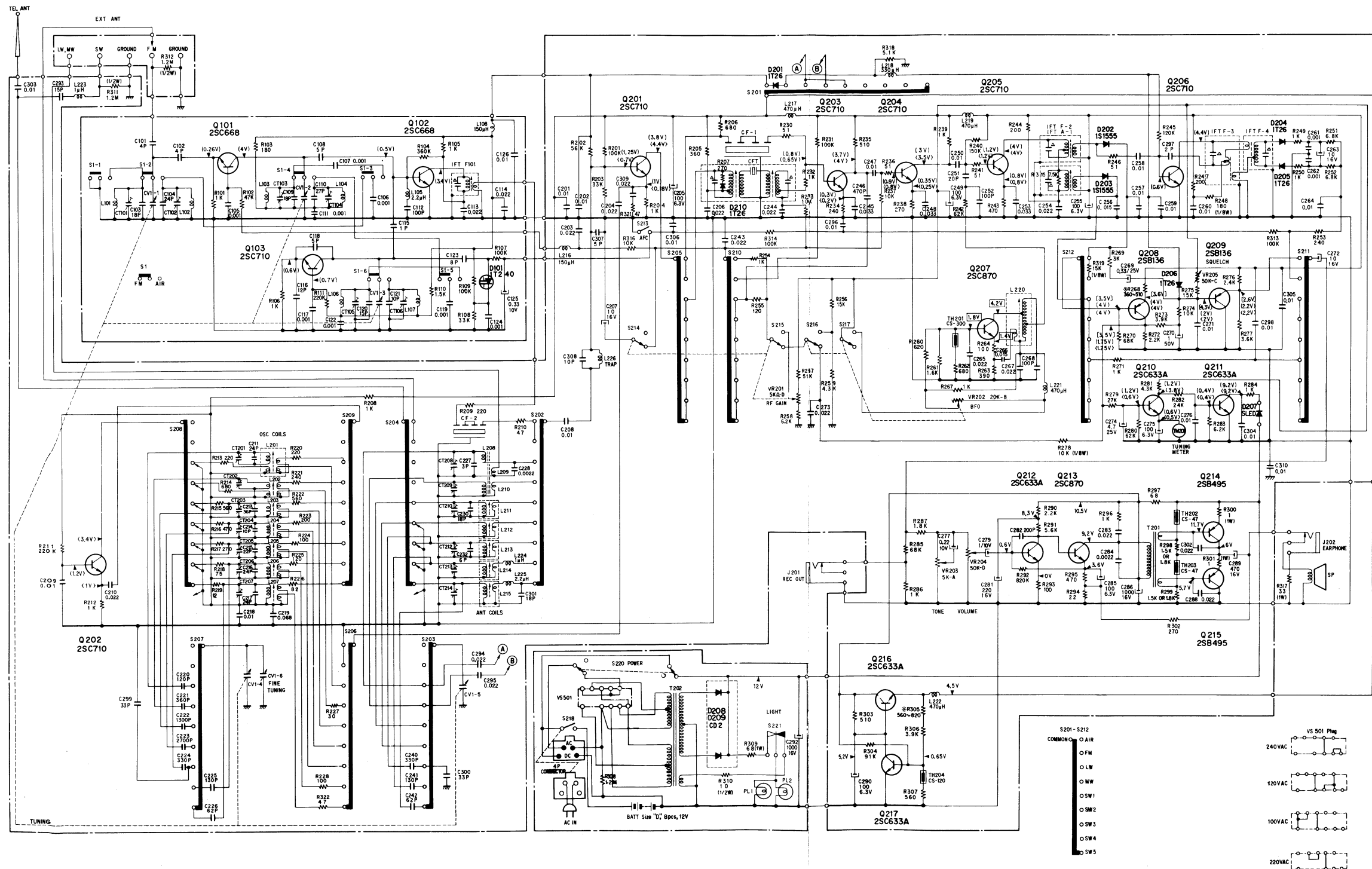

Fig. 3-9. Adjusting parts locations

CRF-5090 CRF-5090

SECTION 4 DIAGRAMS

4-1. SCHEMATIC DIAGRAM



Notes:

1. All resistance values in Ω and all capacitance values in μF unless otherwise noted.
2. All voltages measured to ground circuit with a dc voltmeter with no signal received. Variations may be noted due to normal production tolerances.
3. The values in () measured with band selector set to FM, in [] AIR with SQUELCH control at fully counterclockwise position and in \square MW with BFO control set to ON.
4. Capacitors marked Δ built in i-f transformers and ceramic filter.

D101 : 1T240

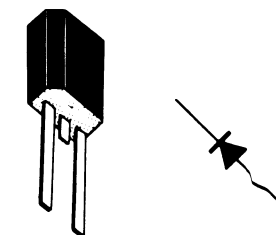

D201, D204~D206, D210 : 1T26
 D202, D203 : 1S1555

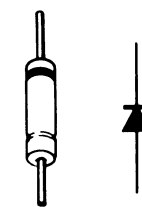

D208, D209 : CD2

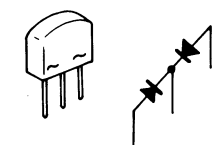

CRF-5090 CRF-5090

4-2. MOUNTING DIAGRAM

Q101, Q102 : 2SC668

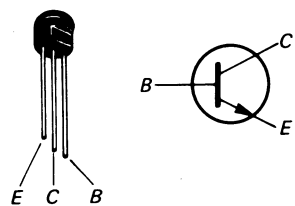

Q103, Q201-Q206 : 2SC710
Q207, Q213 : 2SC870

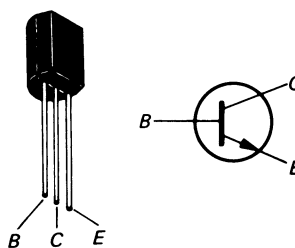

Q208, Q209 : 2SB136
Q214, Q215 : 2SB495

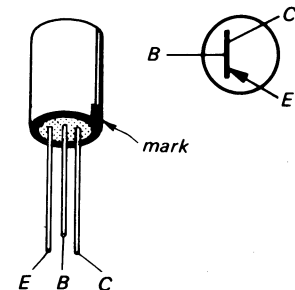

Q210-Q212, Q216, Q217 : 2SC633A

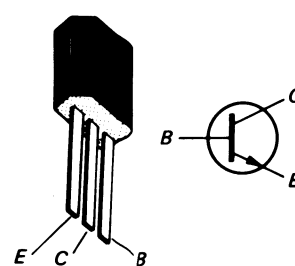

D207 : SLED

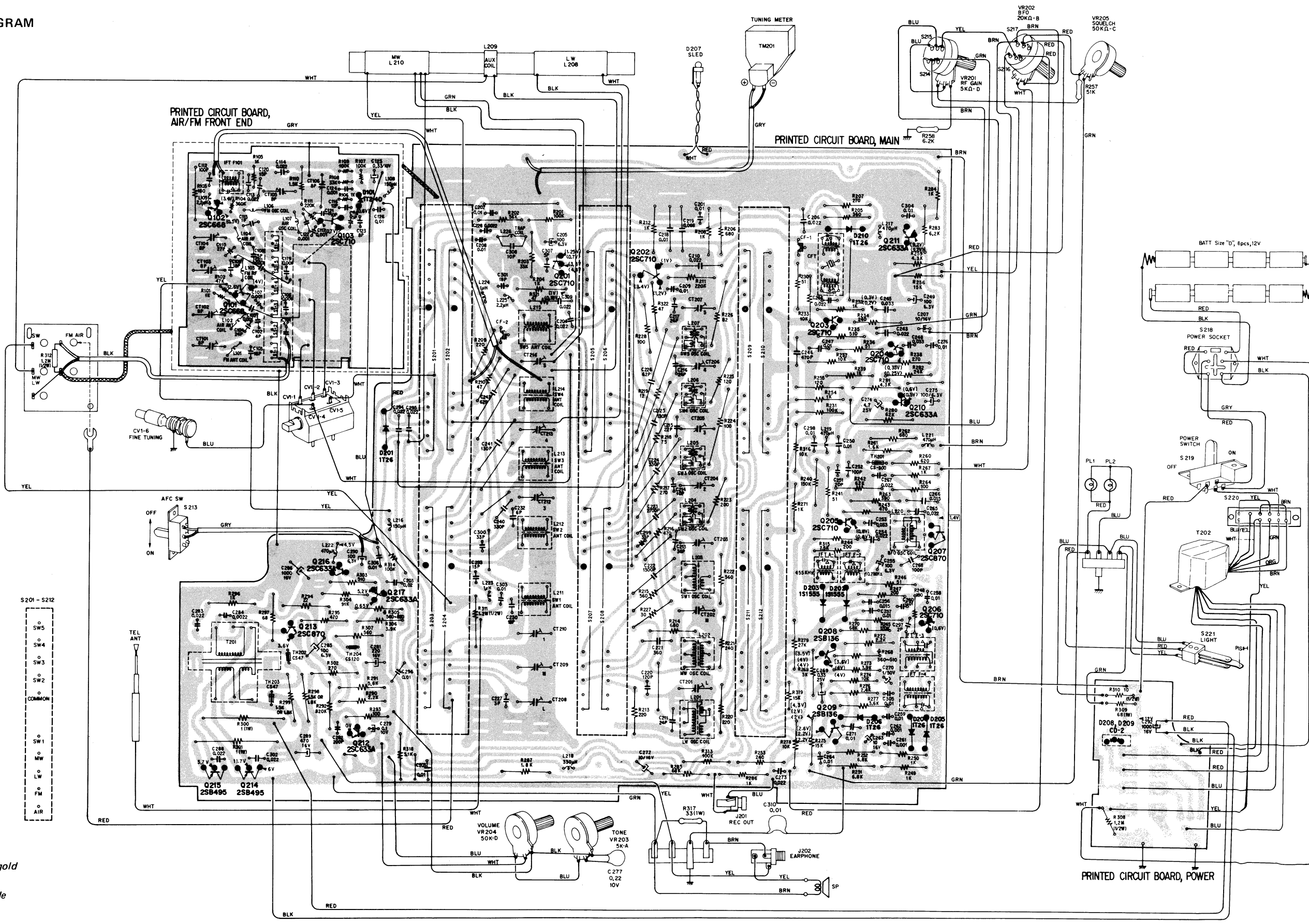
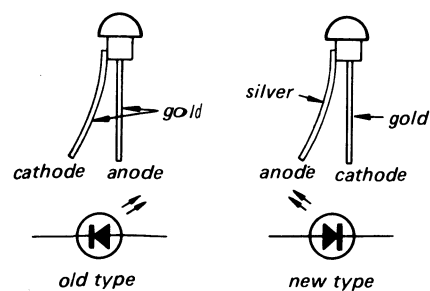

- SW5
- SW4
- SW3
- SW2
- COMMON
- SW1
- MW
- LW
- FM
- AIR

CRF-5090 CRF-5090

5-2. EXPLODED VIEW (2)

Parts without part numbers and names are not available.

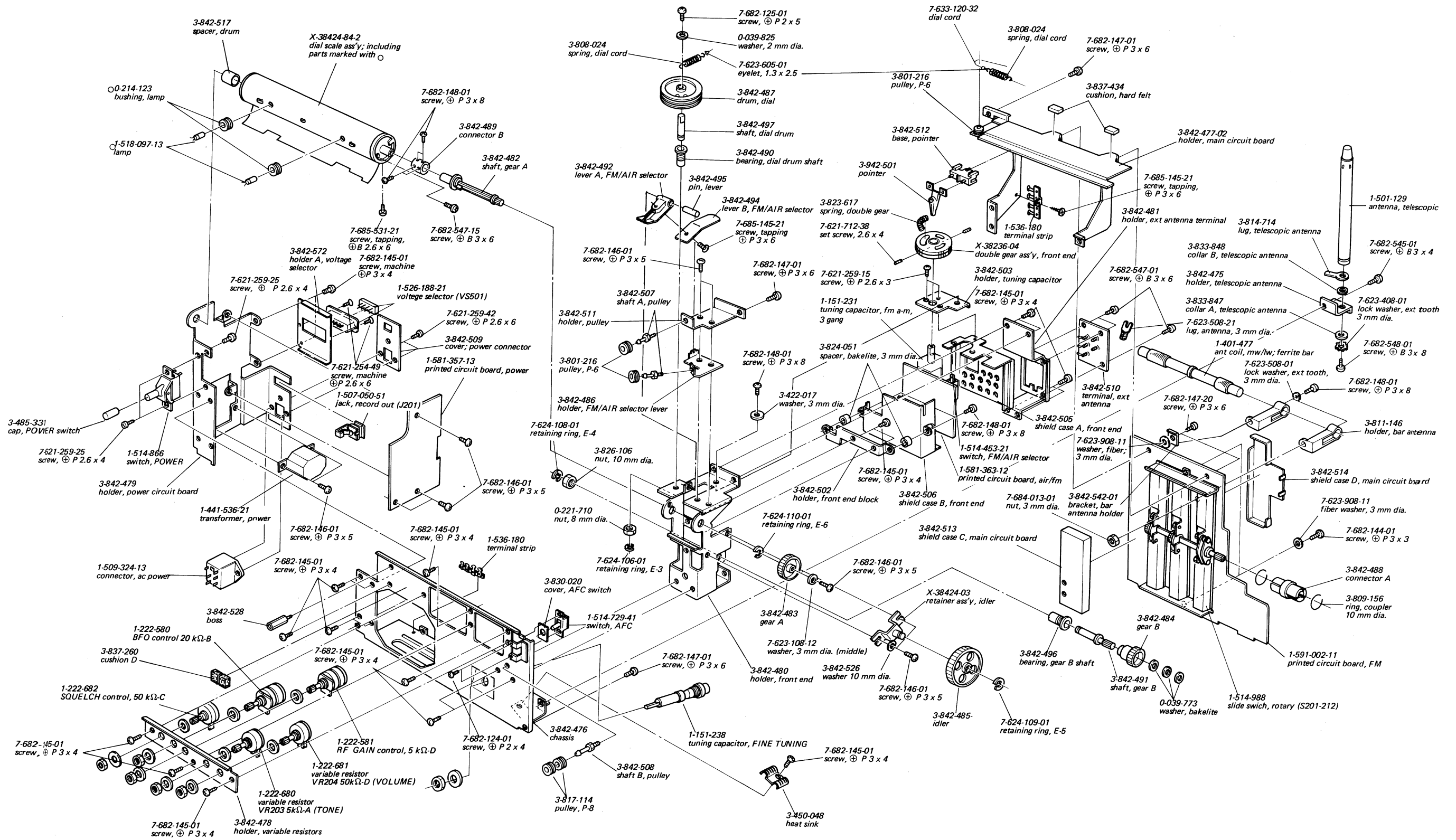

CRF-5090 CRF-5090

**SECTION 6
ELECTRICAL PARTS LIST**

5-3. PACKING

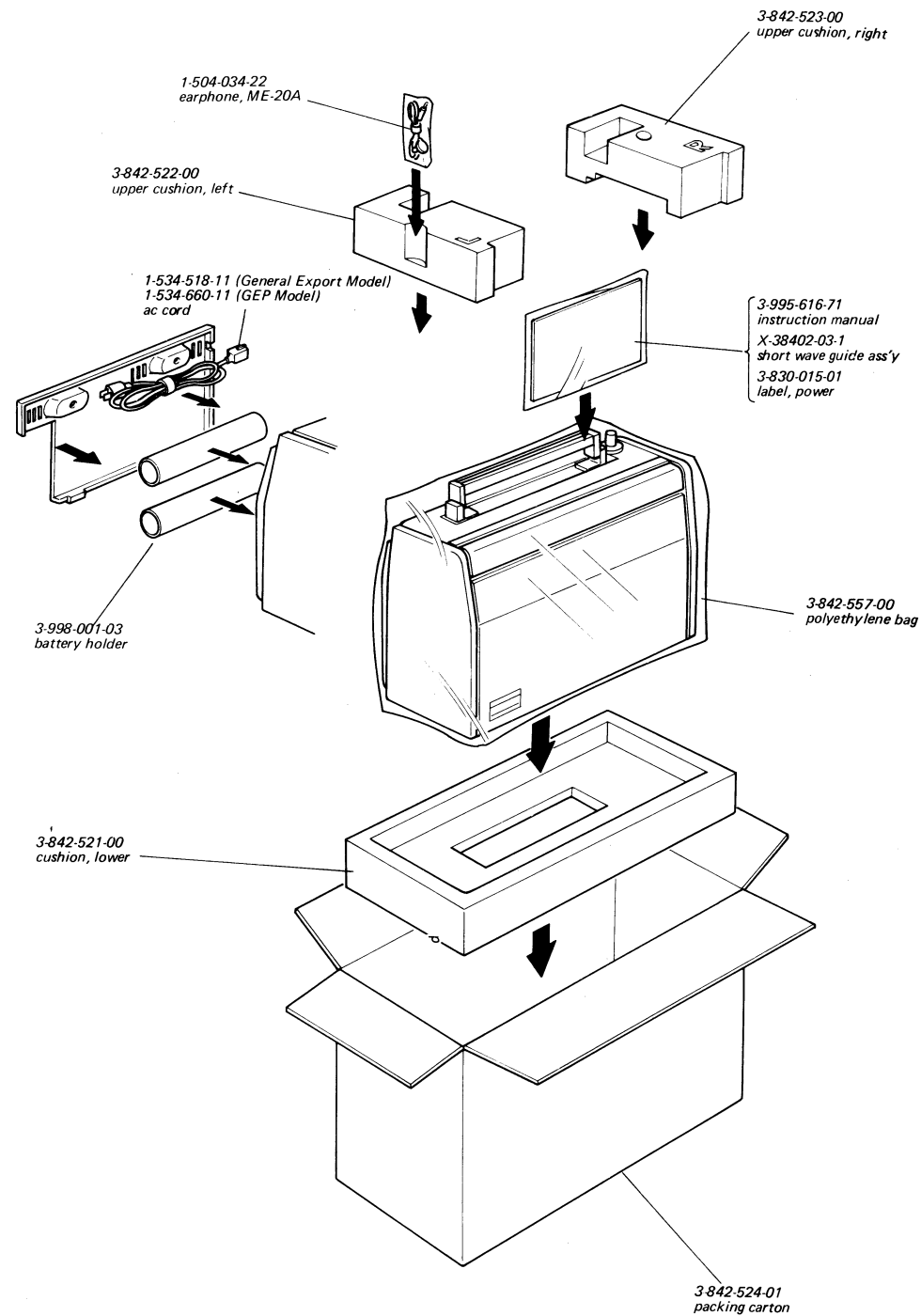

<u>Ref. No.</u>	<u>Part No.</u>	<u>Description</u>	<u>Ref. No.</u>	<u>Part No.</u>	<u>Description</u>
SEMICONDUCTORS					
Q101		transistor 2SC668	L205	1-405-499	osc coil, SW3
Q102		transistor 2SC668	L206	1-405-500	osc coil, SW4
Q103		transistor 2SC710	L207	1-405-501	osc coil, SW5
Q201		transistor 2SC710	L208	1-401-477	ant coil, LW/MW; ferrite bar
Q202		transistor 2SC710	L209		
Q203		transistor 2SC710	L210		
Q204		transistor 2SC710	L211	1-401-373	ant coil, SW1
Q205		transistor 2SC710	L212	1-401-478	ant coil, SW2
Q206		transistor 2SC710	L213	1-401-479	ant coil, SW3
Q207		transistor 2SC870	L214	1-401-480	ant coil, SW4
Q208		transistor 2SB136	L215	1-401-481	ant coil, SW5
Q209		transistor 2SB136	L216	1-407-171	150 μH, micro inductor
Q210		transistor 2SC633A	L217	1-407-177	470 μH, micro inductor
Q211		transistor 2SC633A	L218	1-407-175	330 μH, micro inductor
Q212		transistor 2SC633A	L219	1-407-177	470 μH, micro inductor
Q213		transistor 2SC870	L220	1-405-502	osc coil, bfo
Q214		transistor 2SB495	L221	1-407-177	470 μH, micro inductor
Q215		transistor 2SB495	L222	1-407-177	470 μH, micro inductor
Q216		transistor 2SC633A	L223	1-407-178	1 μH, micro inductor
Q217		transistor 2SC633A	L224	1-407-178	1 μH, micro inductor
D101		diode 1T240	L225	1-407-182	2.2 μH, micro inductor
D201		diode 1T26	L226	1-401-201	trap coil
D202		diode 1S1555	IFT F101	1-403-242-15	transformer, FM i-f
D203		diode 1S1555	IFT F-2	1-403-555	transformer, FM i-f
D204		diode 1T26	IFT F-3	1-403-287-11	transformer, FM discriminator; primary
D205		diode 1T26	IFT F-4	1-403-287-21	transformer, FM discriminator; secondary
D206		diode 1T26	IFT A-1	1-403-174	transformer, AM i-f
D207		diode SLED	CF1	1-527-184-11	ceramic filter, FM i-f
D208-D209		diode CD-2		1-527-184-15	
D210		diode 1T26	CF2	1-527-184-11	ceramic filter, FM i-f
TH201	8-690-005	thermistor CS300		1-527-184-15	
TH202	8-691-002-11	thermistor CS47	CF3	1-403-165-21	ceramic filter, AM i-f
TH203	8-691-002-11	thermistor CS47	T201	1-423-140	transformer, driver
TH204	8-691-001-11	thermistor CS120	T202	1-441-536-21	transformer, power

COILS AND TRANSFORMERS

L101	1-425-350	ant coil, FM
L102	1-405-503	ant coil, AIR
L103	1-425-350	rf coil, FM
L104	1-405-503	rf coil, AIR
L105	1-407-182	2.2 μH, micro inductor
L106	1-405-503	osc coil, FM
L107	1-405-503	osc coil, AIR
L108	1-407-171	150 μH, micro inductor
L201	1-405-497	osc coil, LW
L202	1-405-399	osc coil, MW
L203	1-405-451	osc coil, SW1
L204	1-405-498	osc coil, SW2

CAPACITORS

All fixed capacitors are in μF unless otherwise specified.

CV1-1~5	1-151-231	tuning capacitor, FM/AM 3-gang
CV1-6	1-151-238	tuning capacitor, FINE TUNING
CT101	1-141-097-21	capacitor, trimmer
CT102	1-141-097-21	capacitor, trimmer
CT103	1-141-097-21	capacitor, trimmer
CT104	1-141-097-21	capacitor, trimmer
CT105	1-141-097-21	capacitor, trimmer
CT106	1-141-097-21	capacitor, trimmer
C101	1-102-937	4 pF ceramic
C102	i-102-937	4 pF ceramic
C103	1-102-953	18 pF ceramic
C104	1-102-960	24 pF ceramic

<u>Ref. No.</u>	<u>Part No.</u>	<u>Description</u>		<u>Ref. No.</u>	<u>Part No.</u>	<u>Description</u>	
C105	1-102-918	0.001	ceramic	C218	1-105-673-12	0.01	mylar
C106	1-102-918	0.001	ceramic	C219	1-105-683-12	0.068	mylar
C107	1-102-918	0.001	ceramic	C220	1-107-087	120 pF	silvered mica
C108	1-102-942	5 pF	ceramic	C221	1-107-182	370 pF	silvered mica
C109	1-102-953	18 pF	ceramic	C222	1-103-728	1300 pF	styrol
C110	1-102-961	27 pF	ceramic	C223	1-103-735	2700 pF	styrol
C111	1-105-661-12	0.001	mylar	C224	1-107-097	330 pF	silvered mica
C112	1-107-085	100 pF	mica	C225	1-107-088	130 pF	silvered mica
C113	1-102-924	0.022	ceramic	C226	1-107-080	62 pF	silvered mica
C114	1-102-924	0.022	ceramic	C227	1-102-940	3 pF	ceramic
C115	1-102-934	1 pF	ceramic	C228	1-105-665-12	0.0022	mylar
C116	1-102-510	12 pF	ceramic	C229		
C117	1-102-918	0.001	ceramic	C230	1-102-953	18 pF	ceramic
C118	1-102-864	5 pF	ceramic	C231		
C119	1-102-918	0.001	ceramic	C232	1-102-943	6 pF	ceramic
C120	1-102-880	15 pF	ceramic	C233		
C121	1-101-999	10 pF	ceramic	C234		
C122	1-105-661-12	0.001	mylar	C235		
C123	1-102-865	8 pF	ceramic	C236		
C124	1-105-661-12	0.001	mylar	C237		
C125	1-127-021	0.33	10 V electrolytic (alox)	C238		
C126	1-105-673-12	0.01	mylar	C239		
CT201	1-141-140	capacitor,	trimmer	C240	1-107-097	330 pF	silvered mica
CT202	1-141-140	capacitor,	trimmer	C241	1-107-088	130 pF	silvered mica
CT203	1-141-140	capacitor,	trimmer	C242	1-107-080	62 pF	silvered mica
CT204	1-141-140	capacitor,	trimmer	C243	1-105-677-12	0.022	mylar
CT205	1-141-140	capacitor,	trimmer	C244	1-105-677-12	0.022	mylar
CT206	1-141-140	capacitor,	trimmer	C245	1-105-679-12	0.033	mylar
CT207	1-141-140	capacitor,	trimmer	C246	1-107-185	470 pF	silvered mica
CT208	1-141-140	capacitor,	trimmer	C247	1-105-673-12	0.01	mylar
CT209	1-141-140	capacitor,	trimmer	C248	1-105-679-12	0.033	mylar
CT210	1-141-140	capacitor,	trimmer	C249	1-121-491	100	6.3 V electrolytic
CT211			C250	1-105-673-12	0.01	mylar
CT212	1-141-140	capacitor,	trimmer	C251	1-107-068	20 pF	silvered mica
CT213	1-141-140	capacitor,	trimmer	C252	1-107-085	100 pF	silvered mica
CT214	1-141-140	capacitor,	trimmer	C253	1-105-679-12	0.033	mylar
C201	1-105-673-12	0.01	mylar	C254	1-105-677-12	0.022	mylar
C202	1-105-673-12	0.01	mylar	C255	1-121-491	100	6.3 V electrolytic
C203	1-101-924	0.022	ceramic	C256	1-105-675-12	0.015	mylar
C204	1-105-677-12	0.022	mylar	C257	1-105-673-12	0.01	mylar
C205	1-121-491	100	6.3 V electrolytic	C258	1-105-673-12	0.01	mylar
C206	1-101-924	0.022	ceramic	C259	1-105-673-12	0.01	mylar
C207	1-121-471	10	16 V electrolytic	C260	1-105-673-12	0.01	mylar
C208	1-105-673-12	0.01	mylar	C261	1-105-661-12	0.001	mylar
C209	1-105-673-12	0.01	mylar	C262	1-105-661-12	0.001	mylar
C210	1-105-677-12	0.022	mylar	C263	1-121-471	10	16 V electrolytic
C211	1-102-960	24 pF	ceramic	C264	1-105-673-12	0.01	mylar
C212			C265	1-105-677-12	0.022	mylar
C213	1-102-964	36 pF	ceramic	C266	1-105-675-12	0.015	mylar
C214	1-102-947	10 pF	ceramic	C267	1-105-677-12	0.022	mylar
C215	1-102-959	22 pF	ceramic	C268	1-102-734	100 pF	ceramic
C216	1-102-960	24 pF	ceramic	C269	1-127-082	0.33	10 V electrolytic (alox)
C217	1-102-960	24 pF	ceramic	C270	1-121-442	1	50 V electrolytic

CRF-5090

<u>Ref. No.</u>	<u>Part No.</u>	<u>Description</u>		<u>Ref. No.</u>	<u>Part No.</u>	<u>Description</u>
C271	1-105-673-12	0.01	mylar	R104	1-244-734	360 k
C272	1-121-471	10	16 V electrolytic	R105	1-242-673	1 k
C273	1-105-677-12	0.022	mylar	R106	1-242-673	1 k
C274	1-121-464	4.7	25 V electrolytic	R107	1-242-721	100 k
C275	1-121-491	100	6.3 V electrolytic	R108	1-242-709	33 k
C276	1-105-673-12	0.01	mylar	R109	1-242-721	100 k
C277	1-127-046	0.22	10 V electrolytic (alox)	R110	1-242-677	1.5 k
C278			R111	1-242-729	220 k
C279	1-127-045	0.1	10 V electrolytic (alox)	R201	1-244-721	100 k
C280			R202	1-244-715	56 k
C281	1-121-421	220	16 V electrolytic	R203	1-244-709	33 k
C282	1-102-098	470 pF	ceramic	R204	1-244-673	1 k
C283	1-105-677-12	0.022	mylar	R205	1-244-662	360
C284	1-105-665-12	0.0022	mylar	R206	1-244-669	680
C285	1-121-491	100	6.3 V electrolytic	R207	1-244-659	270
C286	1-121-186	1000	16 V electrolytic	R208	1-244-673	1 k
C287			R209	1-244-657	220
C288	1-105-677-12	0.022	mylar	R210	1-244-641	47
C289	1-121-426	470	16 V electrolytic	R211	1-244-729	220 k
C290	1-121-491	100	6.3 V electrolytic	R212	1-244-673	1 k
C291			R213	1-244-657	220
C292	1-121-186	1000	16 V electrolytic	R214	1-244-669	680
C293	1-102-951	15 pF	ceramic	R215	1-244-667	560
C294	1-101-924	0.022	ceramic	R216	1-244-665	470
C295	1-101-924	0.022	ceramic	R217	1-244-659	270
C296	1-105-673-12	0.01	mylar	R218	1-244-646	75
C297	1-102-939	2 pF	ceramic	R219	1-244-627	12
C298	1-105-673-12	0.01	mylar	R220	1-244-657	220
C299	1-102-963	33 pF	ceramic	R221	1-244-658	240
C300	1-102-963	33 pF	ceramic	R222	1-244-667	560
C301	1-102-953	18 pF	ceramic	R223	1-244-656	200
C302	1-105-677-12	0.022	mylar	R224	1-244-649	100
C303	1-101-923	0.01	ceramic	R225	1-244-651	120
C304	1-101-923	0.01	ceramic	R226	1-244-647	82
C305	1-105-673-12	0.01	mylar	R227	1-244-636	30
C306	1-101-923	0.01	ceramic	R228	1-244-649	100
C307	1-102-942	5 pF	ceramic	R229	
C308	1-102-947	10 pF	ceramic	R230	1-244-642	51
C309	1-105-677-12	0.022	mylar	R231	1-244-721	100 k
C310	1-101-923	0.01	ceramic	R232	1-244-673	1 k
				R233	1-244-697	10 k
				R234	1-244-658	240
				R235	1-244-666	510
				R236	1-244-642	51
				R237	1-244-697	10 k
				R238	1-244-659	270
				R239	1-244-673	1 k
				R240	1-244-725	150 k
				R241	1-244-642	51
				R242	1-244-716	62 k
				R243	1-244-665	470
				R244	1-244-656	200
				R245	1-244-723	120 k
				R246	1-244-642	51
				R247	1-244-656	200

RESISTORS

All fixed resistors are in Ω , $\frac{1}{4}W$, $\pm 5\%$, carbon film type unless otherwise noted.

VR 201	1-222-581	RF GAIN control	5 k Ω D
VR 202	1-222-580	BFO control	20 k Ω B
VR 203	1-222-680	TONE control	5 k Ω A
VR 204	1-222-681	VOLUME control	50 k Ω D
VR 205	1-222-682	SQUELCH control	50 k Ω C
R101	1-242-673	1 k	
R102	1-242-713	47 k	
R103	1-244-655	180	

CRF-5090

SONY CORPORATION

2C0557-1

© 1972

Printed in Japan

- 26 -