

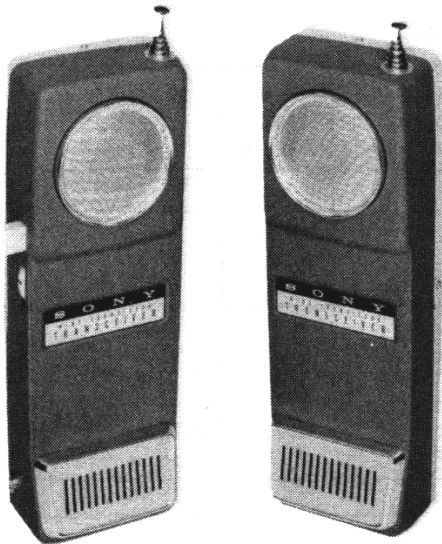

PHOTOFACT[®] with

CIRCUITRACE[®]



TRADE NAME : Sony Model CB-901
 SUPPLIER : Sony Corp. of America
 514 Broadway, New York 12, N. Y.
 TYPE SET : 9 Transistor Transceiver
 POWER SUPPLY : 12 Volts DC
 RATING : 8MA@12VDC (Receive, No Signal)
 18MA@12VDC (Transmit, No Modulation)
 TUNING RANGE : Any one CB Channel 1 thru 23

SONY MODEL CB-901

ALIGNMENT INSTRUCTIONS

Suggested Alignment Tools: A1 thru A8...GENERAL CEMENT #9089, 8728A

RECEIVER ALIGNMENT

Connect DC VTVM across Volume Control.

	SIGNAL GENERATOR	CHANNEL	ADJUST	REMARKS
1.	High side thru .01mfd to base of X1, common to ground. Tune to 455KC (Unmod.) .		A1, A2, A3	Adjust for maximum deflection.
2.	Radiate signal into receiver of antenna. Tune to channel frequency.		A4, A5, A6	Adjust for maximum deflection.

TRANSMITTER ALIGNMENT

ONLY THOSE PERSONS PROPERLY LICENSED ARE PERMITTED TO MAKE REPAIRS OR ADJUSTMENTS WHICH MAY RESULT IN ILLEGAL OPERATION. (REFER TO FCC RULES & REGULATIONS PART 19, SUBPART D, SECTION 19.71)

	SPECIAL INSTRUCTIONS	INDICATOR	ADJUST	REMARKS
1.	Maintain supply voltage at 12V during alignment.	RF Wattmeter (or Field Strength Meter)	A7, A8	Remove jumper. (Refer to capacitor photo). Connect DC milliammeter. Key transmitter. Adjust for maximum on RF wattmeter and MINIMUM on DC milliammeter. Retouch A6 for maximum deflection on RF wattmeter.

HOWARD W. SAMS & CO., INC. Indianapolis 6, Indiana

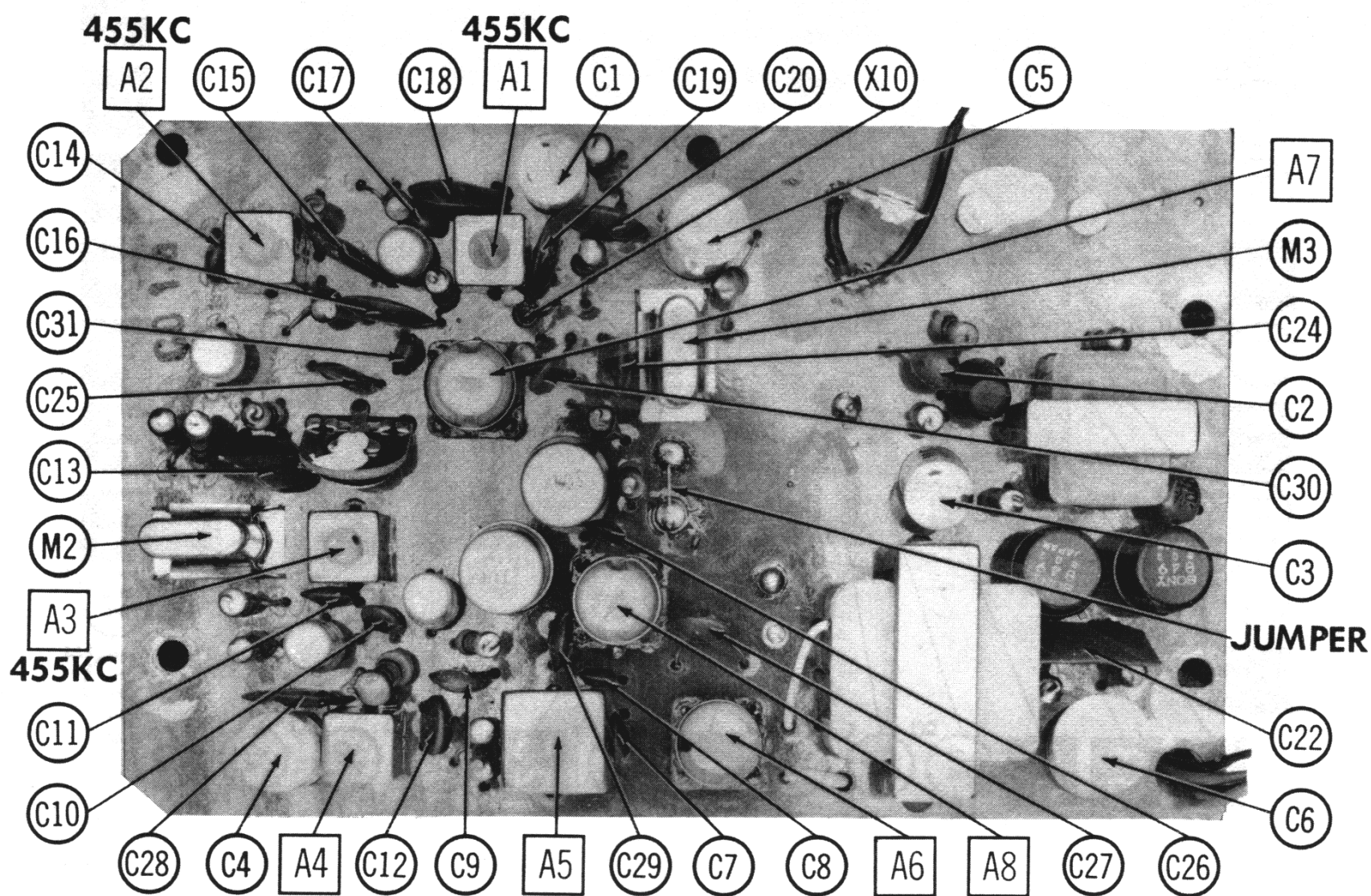
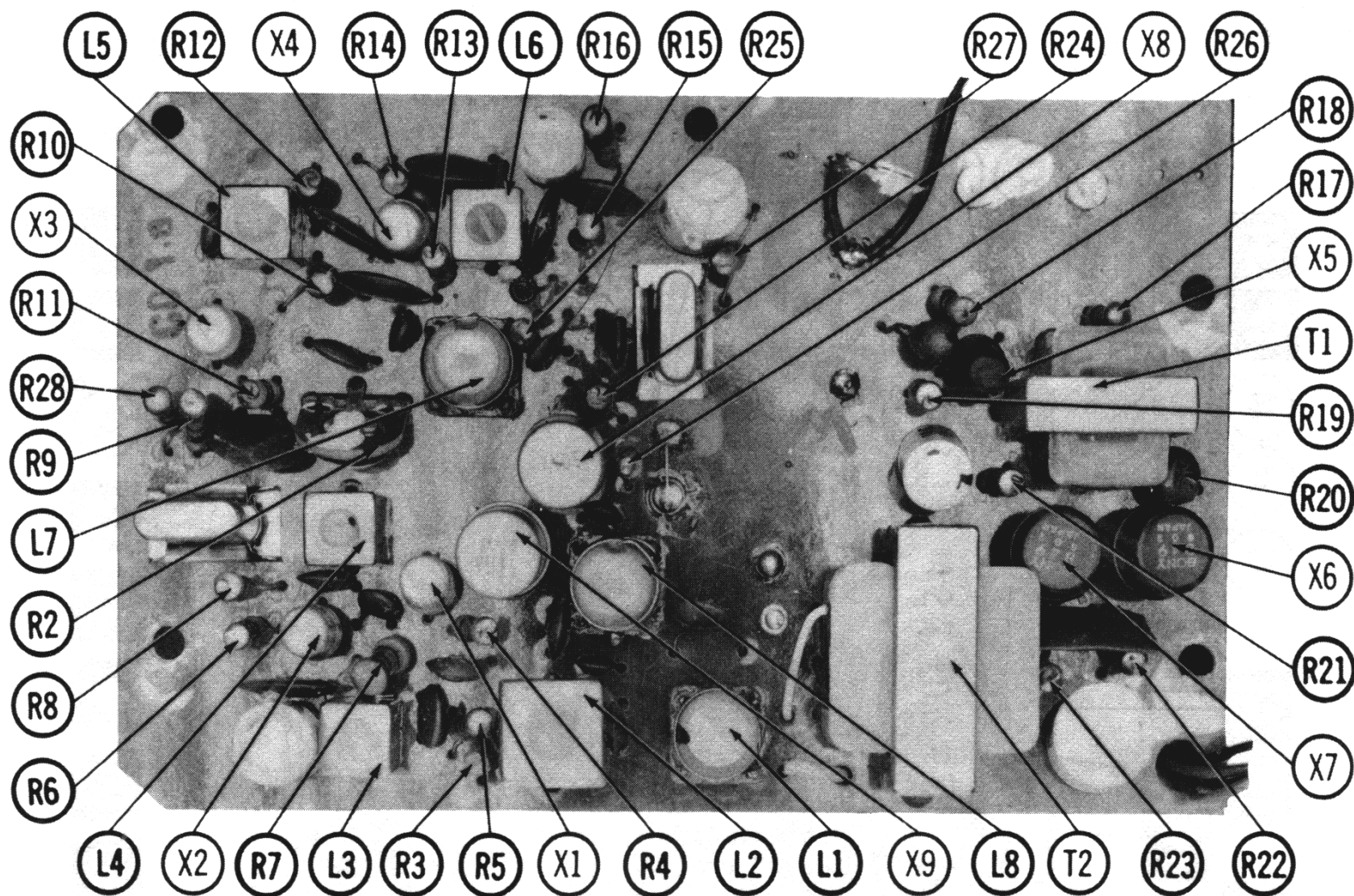

PARTS LIST AND DESCRIPTION

TRANSISTORS

ITEM No.	ORIG. TYPE	USE	REPLACEMENT DATA			NOTES
			DELCO PART No.	GENERAL ELECTRIC PART No.	RCA PART No.	
X1	A122	Mixer	DS25	GE-1		PNP
X2	A122	Rec. Osc.	DS25	GE-1		PNP
X3	C76	1st IF Amp.		GE-7		NPN
X4	C76	2nd IF Amp.		GE-7	2N647	NPN
X5	D64	Driver-Speech Amp.		GE-8	2N408	NPN
X6	B49	Output-Modulator	DS26	GE-2	2N408	PNP
X7	B49	Output-Modulator	DS26	GE-2	2N408	PNP
X8	2SA70	Trans. Osc.	DS34	GE-1		PNP
X9	TTL16	Final Amp.	DS34	GE-1		PNP

POWER RECTIFIERS & SIGNAL DIODES

ITEM No.	MEASURED CURRENT	ORIGINAL Part or Type No.	RECTIFIERS			NOTES
			MALLORY PART No.	RCA PART No.	SARKES TARZIAN PART No.	
X10		1T23			Detector	

ELECTROLYTIC CAPACITORS

ITEM No.	RATING CAP.	VOLT.	REPLACEMENT DATA						
			CORNELL-DUBILIER PART No.	AEROVOX PART No.	CORNELL-DUBILIER PART No.	GENERAL ELECTRIC PART No.	MALLORY PART No.	SPRAGUE PART No.	
C1	30	6	BCD6025	BCD6025	ECPB412	MTI-10	TT6X30	MLY30-6	VL-1092
C2	.3	6		BCD6025	ECPB412	MTI-10	TT6X30	MLY30-6	VL-1092
C3	30	6		BCD15025	ECPB412	MTI-10	TT15X30	MLY25-15	TE-1158
C4	30	15		BCD15025	ECPB412	MTI-10	TT15X30	MLY25-15	TE-1158
C5	30	15		BCD15025	ECPB412	MTI-10	TT15X30	MLY25-15	TE-1158
C6	50	15		BCD15050	NLW50-15	MTI-16		MLY50-15	TE-1160

FIXED CAPACITORS

ITEM No.	RATING	REMARKS	REPLACEMENT DATA						
			AEROVOX PART No.	CENTRALAB PART No.	CORNELL-DUBILIER PART No.	ELMENCOR PART No.	MALLORY PART No.	SPRAGUE PART No.	
C7	100		DI-100	DD-101	LI0T1	CCD-101	CCD-101	GP310	10TS-T10
C8	20		DI-20	DD-200	LI0Q2	CCD-200	CCD-200	GP420	10TS-Q20
C9	.01		TTD-01	CK-103	H05S1			TA-110	TG-S10
C10	20		DI-20	DD-200	LI0Q2	CCD-200	CCD-200	GP420	10TS-Q20
C11	.01		TTD-01	CK-103	H05S1			TA-110	TG-S10
C12	.001		DI-1000	DD-102	LI0D1	CCD-102	CCD-102	GP210	10TS-D10
C13	.04		TTD-05	CK-503	H05S5			GP210	TG-S50
C14	1		NPO-DI 1	TCZ-1	H05S5			CNO-510	10TCC-V10
C15	.04		TTD-05	CK-503	H05S5			CNO-510	TG-S50
C16	.04		TTD-05	CK-503	H05S5			CNO-510	TG-S50
C17	1		NPO-DI 1	TCZ-1	H05S5			CNO-510	10TCC-V10
C18	.04		TTD-05	CK-503	H05S5			TA-120	TG-S20
C19	.02		TTD-02	CK-203	H05S2			TA-120	TG-S20
C20	.02		TTD-02	CK-203	H05S2			TA-110	TG-S10
C21	.01		TTD-01	CK-103	H05S1			GP420	10TS-Q20
C22	.1		TTD-1	CK-104	H05P1			GP220	10TS-D20
C23	20		DI-20	DD-200	LI0Q2	CCD-200	CCD-200	GP220	10TS-Q20
C24	.002		DI-2000	DD-202	LI0D2	CCD-202	CCD-202	GP412	10TS-Q12
C25	.01		TTD-01	CK-103	H05S1	CCD-120	CCD-120	GP210	10TS-D10
C26	12		DI-12	DD-102	LI0Q12	CCD-102	CCD-102	GP210	10TS-S50
C27	.001		DI-1000	DD-102	LI0Q12	CCD-102	CCD-102	GP210	10TS-S50
C28	.04		TTD-05	CK-503	H05S5	CCD-502	CCD-502	TA-250	TG-D50
C29	.005		TTD-005	CK-502	H05D5	CCD-Q20	CCD-Q20	GP420	10TS-Q20
C30	20		DI-20	DD-200	LI0Q2	CCD-120	CCD-120	GP412	10TS-Q12
C31	12		DI-12	DD-120	LI0Q12	CCD-120	CCD-120	GP412	10TS-Q12

CONTROLS

All wattages 1/2 watt, or less, unless otherwise listed.

ITEM No.	USE	RESIST-ANCE	REPLACEMENT DATA			
			SONY PART No.	CENTRALAB PART No.	CLAROSTAT PART No.	CTS-IRC PART No.
R1	Volume & Switch	5000Ω	36, 09			
R2	Transmit Osc. Bias	2000Ω				

COILS (RF-IF)

ITEM No.	USE	REPLACEMENT DATA					NOTES
		SONY PART No.	MERIT PART No.	MILLER PART No.	STANCOR PART No.	WORKMAN PART No.	
L1	Ant. Load						
L2	Ant. Coll						
L3	Rec. Osc.						
L4	1st IF						
L5	2nd IF						
L6	3rd IF						
L7	Transmit Osc.						
L8	Final						

TRANSFORMER (DRIVER)

ITEM No.	TURNS RATIO	REPLACEMENT DATA				NOTES
		SONY PART No.	MERIT PART No.	STANCOR PART No.	THORADARSON PART No.	
T1	1.3 1	423-045				

TRANSFORMER (AUDIO OUTPUT)

ITEM No.	IMPEDANCE	REPLACEMENT DATA				NOTES
		SONY PART No.	MERIT PART No.	STANCOR PART No.	THORADARSON PART No.	
T2	1000Ω CT	6-8Ω	427-026			

BATTERIES

ITEM No.	VOLTAGE	SONY PART No.	REPLACEMENT DATA			NOTES
			BURGESS	EVEREADY	MALLORY	
M1	1.5V	930	1015		M-15R (Zinc-Carbon) MN-1500 (Manganese) ZM-9 (Mercury)	

MISCELLANEOUS

ITEM No.	PART NAME	SONY PART No.	NOTES	REPLACEMENT DATA	
				ITEM No.	TYPE
M2	Crystal		Receive		
M3	Crystal		Transmit		
M4	Switch		Receive-Transmit		

WIRING DATA

General-use Hook-up Wire	Use BELDEN No. 8530 (Solid) Available in 12 Colors
Shielded Antenna Lead	8524 (Stranded) Available in 12 Colors
Coiled Microphone Cable	Use BELDEN No. 8214 Lowest Loss (RG-8/U Type)
Ignition Noise Suppression	Use BELDEN No. 8237 Low Loss (RG-8/U)
Bonding Strap	Use BELDEN No. 8259 (Stranded) Miniature (RG-58/U)
	8498 Single Conductor Shielded (Neoprene)
	7300-Series Spark-Plug Sets
	8661 (3/8 In.)

SONY MODEL CB-901

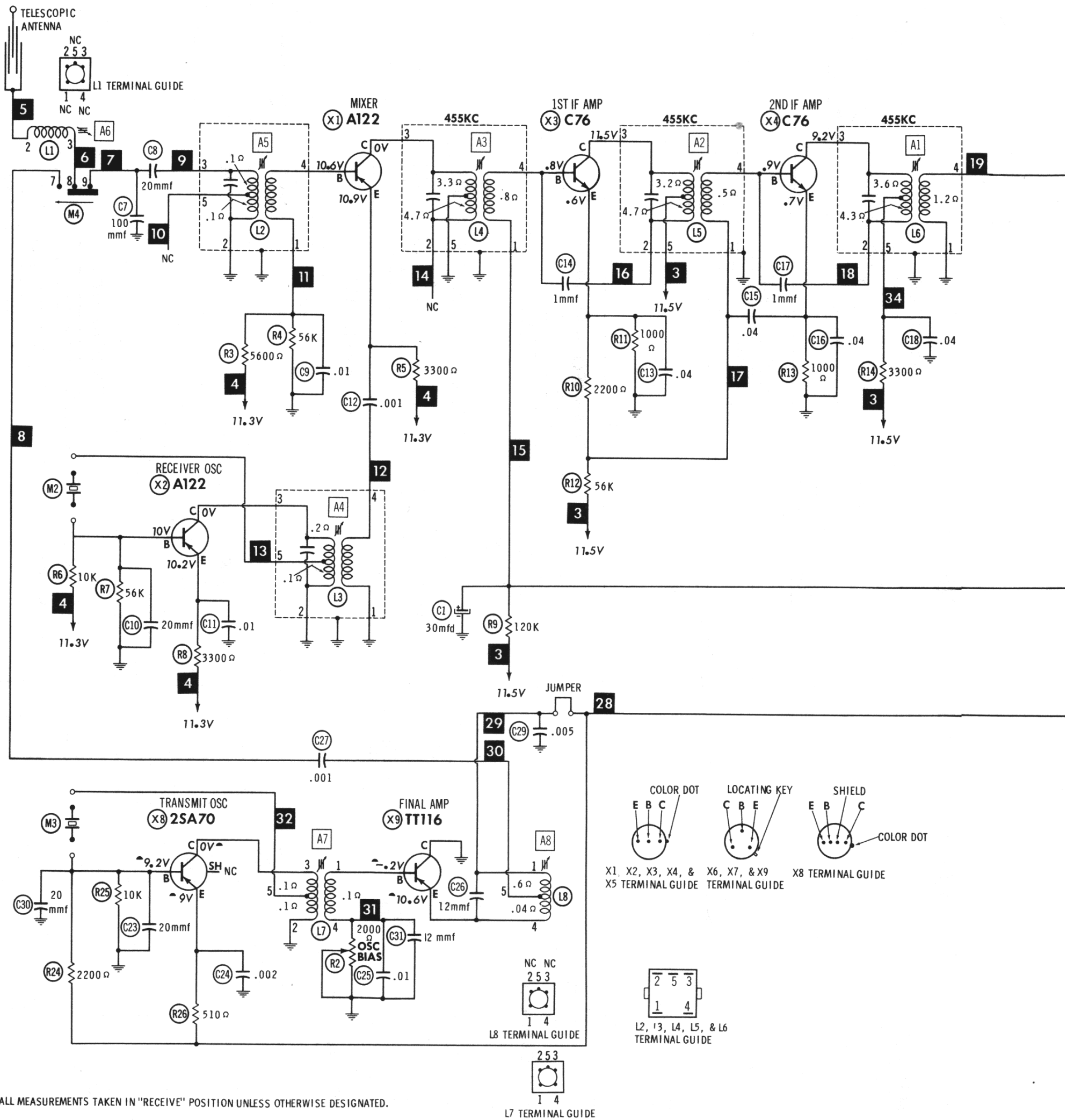

ALL MEASUREMENTS TAKEN IN "RECEIVE" POSITION UNLESS OTHERWISE DESIGNATED.

▲ TAKEN IN "TRANSMIT" POSITION.

NUMBERS ASSIGNED TO COILS, SWITCHES, PLUGS, SOCKETS, AND TRANSFORMERS ARE TO FACILITATE CIRCUIT TRACING OR COMPONENT REPLACEMENT AND MAY NOT NECESSARILY BE FOUND ON THE UNIT.

RESISTANCE MEASUREMENTS NOT GIVEN BECAUSE OF THE WIDE VARIATION IN INTERNAL TRANSISTOR RESISTANCE.

1. DC voltage measurements taken with vacuum tube voltmeter.
2. Socket connections or transistor terminals are shown as bottom views.
3. Measured values are from socket pin or terminal to common ground.
4. Nominal tolerance on component values makes possible a variation of $\pm 15\%$ in voltage and resistance readings.

A PHOTOFACIT STANDARD NOTATION SCHEMATIC with **CIRCUITRACE**

©Howard W. Sams & Co., Inc. 1963

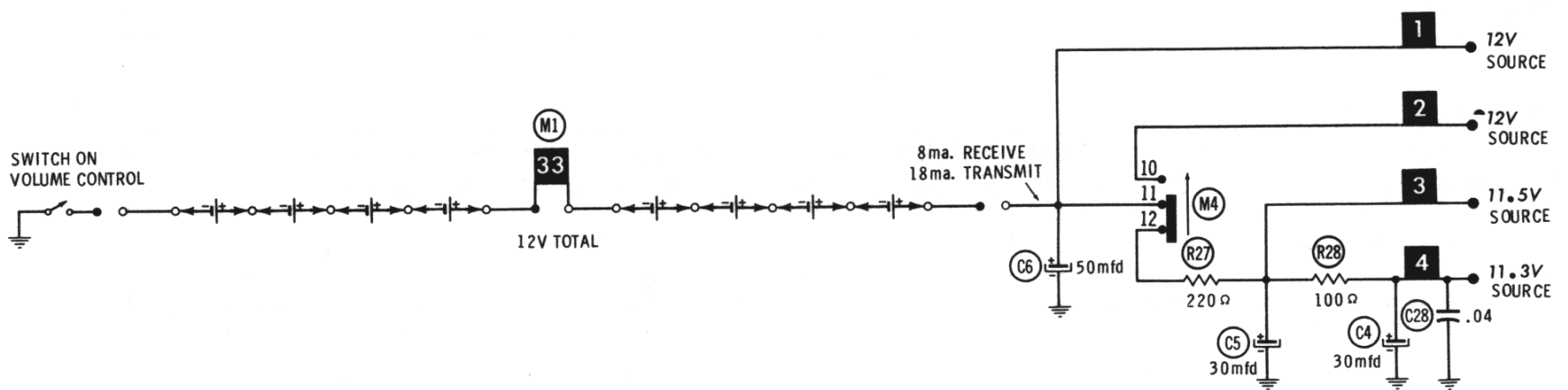
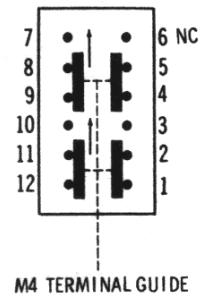
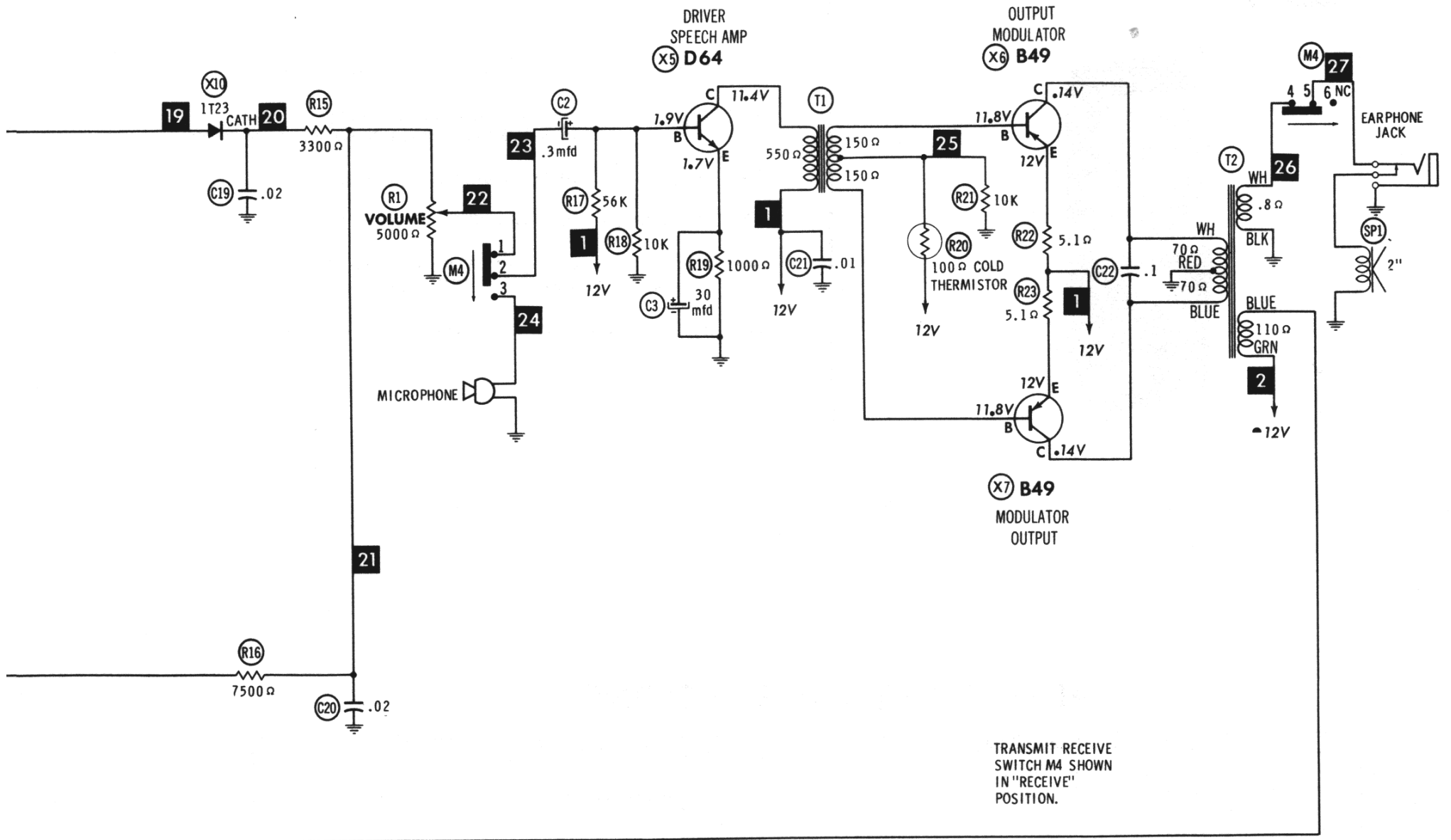

SONY MODEL CB-901