

## A Self-contained Mains-operated Three, having a Generous Output.

IT may still be said that the three-valve set is the most popular on the British market to-day. Three valves give adequate selectivity in relation to the number of stations that can be received. From the listener's standpoint the output stage is far more important than the arrangement of the H.F. amplifier and the range-getting properties of the receiver. It is the output stage that determines quality of reception, and if one can overcome the desire for the novelty of receiving forty continental stations, the reduced number that one will get with the three-valve set are practically free from valve noise, mush, and heterodyning. The three-valve set renders the reception of some ten stations an easy matter, gives an adequate input to the detector, and passes on a signal to the output valve as free of distortion as it is possible to obtain with any other combination of valves.

It is from these considerations that Philips have introduced yet another model in the three-valve range. It has a good single H.F. stage devoid of the defects of cross-modulation, self-oscillation, and the other well-known difficulties associated with two or more H.F. stages. Its detector is the leaky grid arrangement, using the 244V. valve, having values of grid condenser, leak and anode voltage conforming to the requirements of power grid detection, and being distortion-free within wide limits.

In the output stage is the generous power pentode, the PM24A. In comparing receiving sets particular attention should be paid to the type of output valve adopted, for therein largely lies the cost of the set, while the quality of reception is mainly governed by whether or not a generous output valve is fitted. The PM24A delivers a power output of 3,000 milliwatts to the loud speaker, a figure which, by way of comparison, is more than three times that of the average 6-volt battery power valve.

Turning to the details of the circuit, it is to be noted

that the aerial is coupled to the first tuned circuit through a small air condenser having a value of 0.00002 mfd., and by this means aerial dimensions have but little effect upon the tuning positions for given stations and the gang operation of the two tuning condensers. An unusual feature is the dividing of the wave range of 200 to 2,100 metres into three sections instead of the customary two. This renders the set more sensitive as greater signal strength is developed across the tuned circuits. Following the H.F. valve, which is an S4V, is a straightforward tuned anode coupling. A generous H.F. filter follows the detector valve, which is transformer-coupled to the pentode.

The construction is particularly compact, which is largely due to the use of tuning condensers having mica dielectric, a practice concerning which there can be no

criticism. It is probable that solid dielectric condensers such as these will not lend themselves to gang operation, but here, while the two tuning condensers are on a single shaft in order to render control easy, an auxiliary adjustment is provided for rocking the fixed plates of one of the condensers. Thus, the merits are

gained of single-dial control, with the advantage of being able to get the last ounce out of the set by careful adjustment of an individual tuning condenser. The main chassis assembly is carried on a substantial bent iron frame, cadmium-plated to prevent rusting. The wave-change switch has a positive action, and while this fitment is often the cause of trouble in a receiver it is, in this case, owing to its particular form of construction, thoroughly reliable. A powerful snap action indicates the switch positions. Honeycomb-type tuning coils are adopted, and coupling between the aerial and anode coils is avoided by totally enclosing the aerial inductance in a metal compartment.

A new departure is to be found in the mains equipment in the use of a mains transformer suited to supply

### SPECIFICATION.

*H.F. stage with tuned anode coupling and S4V valve.  
Power grid detector, 244V valve. Transformer L.F.  
coupling to power pentode valve, the PM24A.*

*Wave range, 200 to 2,100 metres in three steps. Single-dial  
tuning with trimmer. Reaction and volume controls.*

*Provision for gramophone pick-up. High voltage valve  
rectification.*

*Adaptable for A.C. supplies from 100 to 250 volts and 40  
to 100 cycles.*

*Cone loud speaker with 4-pole balanced armature movement  
and incorporating a choke capacity filter.*

*Price, complete with valves, £25.*



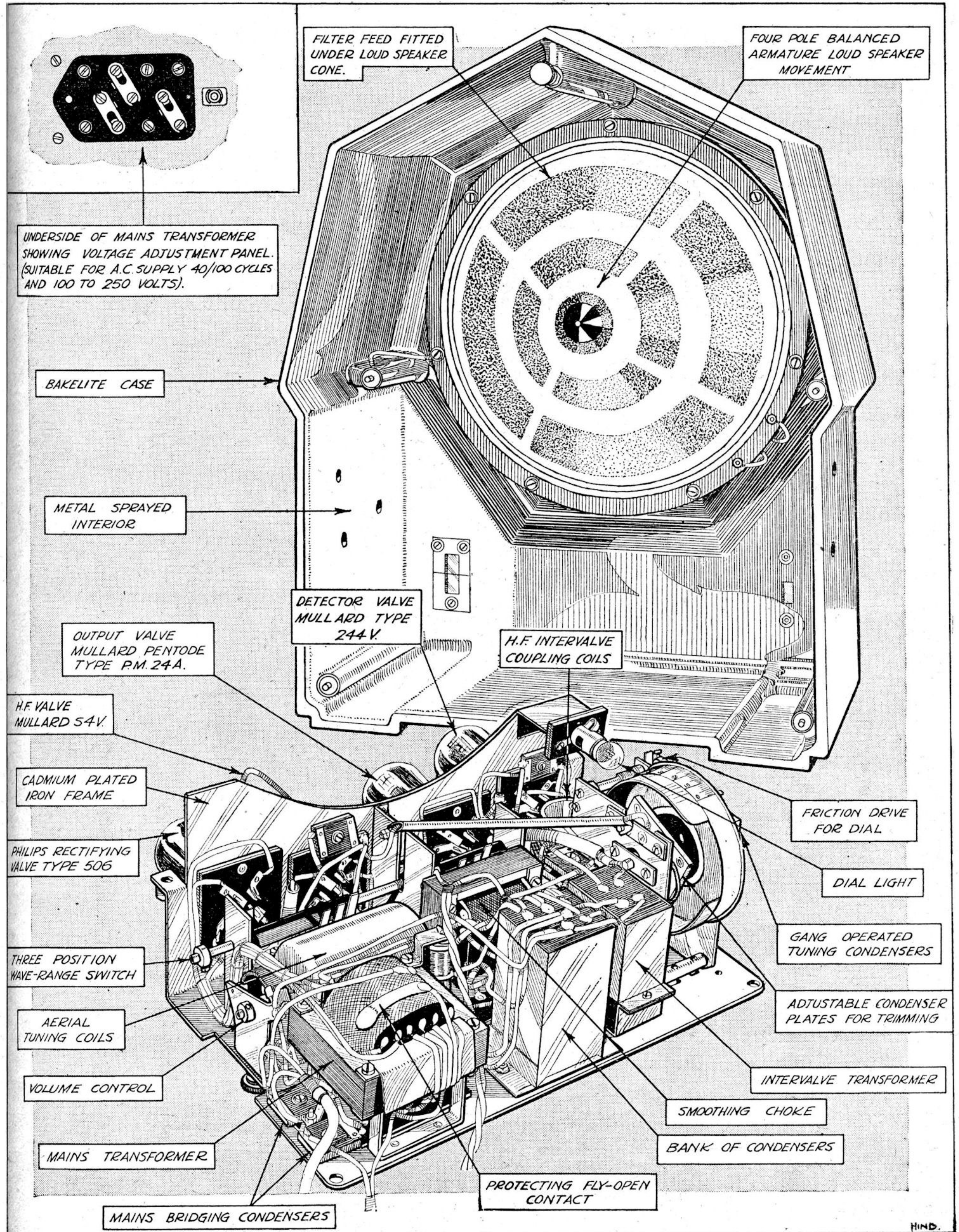

Internal details of construction. The Philips "Radioplayer," type 2634.

HIND.



**Philips Radioplayer.**—

voltages between 100 and 250 and frequencies from 40 to 100 cycles, so that one need not specify the mains requirements of particular localities. A feature of all Philips' sets is a fly-open spring contact, held down by a low melting point alloy which breaks the main supply should an error occur in the set to cause overloading and thus bringing about a small rise in the temperature of the mains transformer. The smoothing equipment is generous, using a gapped-core choke which, combined with other small but important details, gives reception entirely free from mains hum.

A bold and original cabinet design with a conical loud speaker grille of oxidised metal, and the cabinet itself of mottled bakelite, produce a set of tasteful

foreign programmes were received with strength and quality equal to that of the Midland Regional. By combining the loud speaker with the receiver the manufacturers may take into account the characteristics of both in order to get as near as possible to the desired uniform audio-frequency response. The customary measurement of the output over the frequency range was not carried out in this instance, but as an alternative an aural test was applied which revealed practically no falling off in the ability of the set to reproduce the upper frequencies up to 5,000 cycles, while at the lower end of the scale only a slight weakening was observed as the test frequency dropped below 200. This test revealed also a satisfactory absence of marked resonances. This outfit fulfils the requirements of those needing a set of moderate

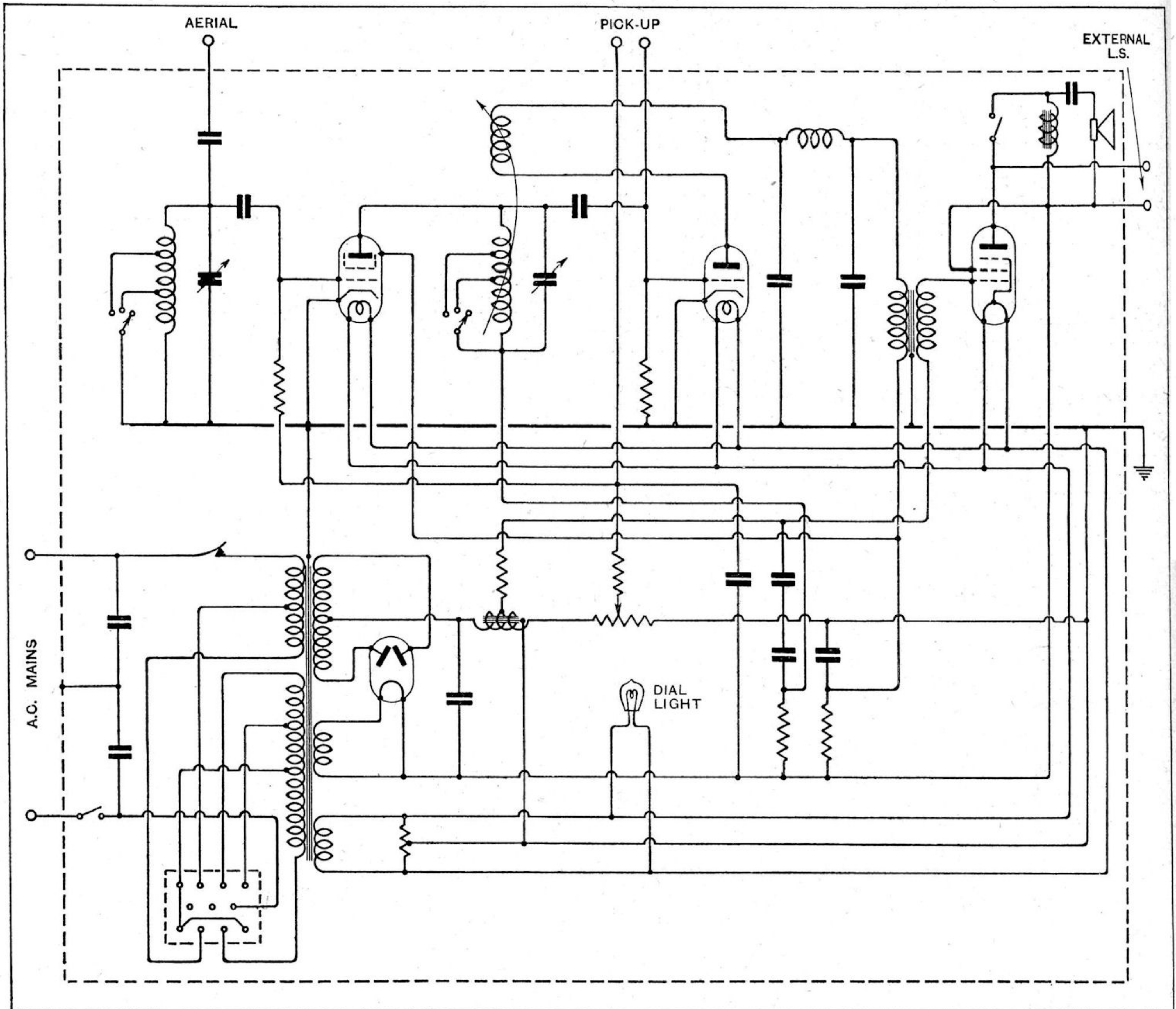

Circuit of Philips three-valve A.C.-operated "Radioplayer," type 2634.

appearance. The knob controls being placed at the sides are convenient to operate.

Used in North London, separation of the two Brookmans Park stations presented no difficulty, and many

range-getting properties and giving good quality reproduction. It is considerably better than the simple sets of slightly lower price and does not include unnecessarily elaborate and expensive equipment.