

# OPERATING INSTRUCTIONS

FOR

## *PRECISION* SERIES 612 AND 614

### TUBE AND BATTERY TESTERS

In the following pages, descriptions of vacuum tube testing procedures, accompanied by supplementary and associated tests such as ballast, condenser, battery testing, etc. are set forth in complete and extensive detail. All of these details will serve as a complete reference testing guide, supplying answers for special and unusual testing problems. In addition, each testing procedure is discussed in great detail, allowing the operator to become intimately familiar not only with all functions of the instrument but with a wide scope of testing techniques and problems.

This complete instruction manual should therefore be THOROUGHLY READ AND DIGESTED before any attempt is made to operate your Series 612 or 614 .....

However, as an aid to rapid reference to routine testing procedure, the CONDENSED procedure on the following page is outlined for CONVENIENCE PURPOSES ONLY:

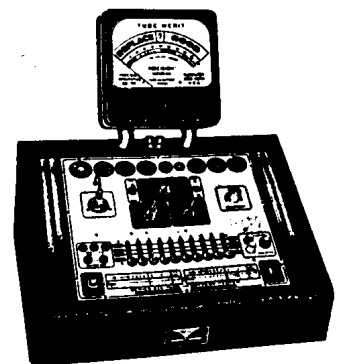
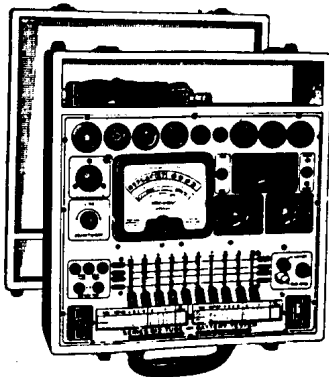

**PRECISION APPARATUS COMPANY, INC.**

92-27 HORACE HARDING BLVD. • ELMHURST, NEW YORK

Export Division: 458 BROADWAY, NEW YORK CITY, U. S. A. • Cables: MORHANEX

CONDENSED TUBE TESTING INSTRUCTIONS

SERIES 612 - 614

1. Depress "OFF" Button and connect attachment plug to 110-125 volts, 50-60 cycle source.
2. Set Controls "A", "B", "C", and the Lever designated under position "D" to positions listed on the roller chart. (ALL OTHER LEVERS REMAIN IN "NORMAL" POSITION.)
3. Release the "OFF" button by depressing the "READ METER" button.
4. Rotate the "LINE ADJUSTMENT" control until meter pointer lines up with "ADJUST LINE" indication.
5. Insert tube and ALLOW TO HEAT.
5. Re-adjust the "LINE ADJUSTMENT CONTROL".
7. Throw each lever individually to "F" position and then back to "NORMAL" (WITH THE EXCEPTION OF THE LEVER(S) WHICH ALREADY HAS BEEN THROWN TO POSITION "D"). Observe the Neon lamp while each lever is thrown to "F" position. If neon lamp glows when \*any lever is thrown to "F" position the tube should be discarded as defective. (\*With the exception of lever(s) listed under "FIL. CONT." on the roller chart.) The tube should be lightly tapped during these tests.
8. If no short circuits have been indicated, and neon glow has been obtained on the "FIL. CONT" lever(s) , then throw the levers indicated on the roll chart under "E" and "F" to the numbered positions indicated.
- . Depress the "READ METER" push button and observe the tube Quality meter reading.

NOTE: All meter indications should be read on the 3 colored "REPLACE - ? - GOOD" scale with the exception of DIODES and special types noted on the roller chart. Meter readings for DIODES and DIODE SECTIONS of multi-purpose tubes should be read on the 2 colored "DIODES-SPECIAL" arc.

**PRECISION APPARATUS COMPANY, INC.**

92-27 HORACE HARDING BLVD. • ELMHURST, NEW YORK

Export Division: 458 BROADWAY, NEW YORK CITY, U. S. A. • Cables: MORHANEX



A. INTRODUCTION

The Series 612 and 614 Tube and Battery Testers are modern lever type vacuum tube testers incorporating the new PRECISION-designed Lever-Operated, Element Distribution System.

The Cathode Conductance test circuit employed, (based upon the basic vacuum tube emissive testing circuit recommended by the Radio Manufacturers' Association,) is implemented to the fullest degree through the use of super-flexible interlocking element switching, providing complete non-arbitrary adaptability to all modern receiving tubes and to tubes yet to be designed.

B. FEATURES

1. TIME-PROVEN CATHODE CONDUCTANCE TESTING CIRCUIT subjects tube to a thoroughly reliable standardized emissive-capability test.
2. OPEN ELEMENT TEST - Special secondary check facilities supplements the primary Cathode Conductance test providing a COMPLETE question-free test.
3. LEVER TYPE ELEMENT DISTRIBUTION SYSTEM - this highly important PRECISION feature COMPLETELY ELIMINATES ALL POSSIBILITIES OF INFLEXIBILITY due to unusual multiple tube basing terminations of new tubes and tubes yet to be developed.
4. QUALITATIVE TUBE MERIT readings directly indicated on a three colored ENGLISH READING SCALE supplemented by a linear scale for tube matching and qualitative comparison purposes. A SPECIAL TWO COLORED SCALE ALSO PROVIDES FOR SIMPLIFIED TEST OF DIODES AND SPECIAL LOW CURRENT TYPE TUBES.
5. DOUBLE-WINDOW, BRASS GEAR-OPERATED ROLLER TUBE CHART provides speedy, easy reading tube references. New charts furnished periodically, upon request, as a no-charge PRECISION SERVICE to all registered owners.
6. DUAL FREE-POINT FILAMENT TERMINAL SELECTION locates terminals of ALL filaments (single, double, center-tapped) regardless of rotating pin positions common to many modern F.M. and television tubes.
7. VISIBLE FILAMENT CONTINUITY TESTS; rapidly performed by the PRECISION NUMBERED LEVER-TYPE DISTRIBUTION SYSTEM; shows up open filaments for all types of tubes regardless of filament base connections. In addition, this PRECISION feature immediately reveals the open section of tapped filaments.
8. ACCOMODATES ALL MODERN TUBE TYPES AND FILAMENT VOLTAGES .75 to 117 volts, including .75, 10, 18.9, 35, 45, 50, 70, 85 and 117 volts. TESTS NOVAL BUTTON 9 PIN TUBES, SUB-MINIATURE TYPES, DOUBLE CAP U.H.F. TYPES, LOKTALS, BANTAM JUNIORS (Miniature Hearing Aid and Pocket Radio Tubes), SINGLE ENDED (T.V. and F.M. Amplifiers) REGULAR OCTALS (MG, G and METALS), SPRAY-SHIELD AND GLASS TYPES, MINIATURE 7 PIN TYPES AND ACORN TUBES.
9. SPECIFIC INDIVIDUAL LOADS AND VOLTAGES available for application to varied classes of tubes.
10. TESTS diodes, triodes, rectifiers, tetrodes, pentodes, multi-purpose tubes, gaseous types such as OY4, OZ3, and OZ4 and remote control gaseous types such as OA4 and 2A4, regardless of varying filament terminations or other rotating element positions.
11. MULTI-SECTION TUBES: Individual tests for each section of multi-section tubes, where required, including visible tests of the fluorescent screen and winking effect on cathode ray indicator tubes and FM/AM alignment ray indicator tubes. No shifting of tubes is necessary to obtain all tests.
12. HOT CATHODE LEAKAGE TEST: Sensitive neon method quickly shows up poor cathode structure in accord with leakage specifications of leading tube manufacturers.
13. DUAL SENSITIVITY HOT INTER-ELEMENT SHORT TESTS made ingeniously simple through the use of PRECISION LEVER DISTRIBUTION SYSTEM, and lens-protected magnified neon lamp. Double sensitivity is made available through the flip of a switch to permit special application tube selection to more rigid standards.
14. NOISE TEST pin jacks incorporated for earphone or amplifier connection. Each element can be separately noise tested through use of the flexible Lever Distribution System.
15. BALLAST TEST: The regular tube test sockets accomodate all ballast unit tests for open and loose elements and leakage between sections of multi-section ballasts; made possible through the rapid-action LEVER DISTRIBUTION SYSTEM.
16. PILOT LIGHT TESTS for all miniature screw base and bayonet type lamps.

17. ACCURACY of the tube test circuit is closely maintained by the use of individual calibrating controls, adjusted and sealed at the factory against laboratory standards, and through use of individual, 1% bridge-calibrated wire wound shunts.
18. LARGE EASY-TO-READ D'Arsonval double-jeweled Meter, accurately balanced and factory-calibrated to within 2 percent.
19. TUBE SELECTION REFERENCES plainly marked on panel in large easy-to-read characters, eliminating memorization or guesswork.
20. PILOT LIGHT ON-OFF INDICATOR.
21. PANEL-MOUNTED FUSE EXTRACTOR POST.
22. MICRO-LINE ADJUSTMENT, read directly on meter, provided by use of continuously variable, heavy duty line voltage control.
23. TELEPHONE-CABLED PLASTIC INSULATED WIRING EMPLOYED THROUGHOUT.
24. PAPER CONDENSER LEAKAGE TESTS. SENSITIVE NEON METHOD.
25. TEST CIRCUITS COMPLETELY ISOLATED FROM POWER LINE.

IMPORTANT PRELIMINARY OPERATING NOTES:

THE FOLLOWING IDENTIFICATIONS AND DESCRIPTIONS SHOULD BE CAREFULLY READ: FULL FAMILIARITY WITH THE CONTROL FUNCTIONS WILL GREATLY FACILITATE TESTING PROCEDURES:

CONTROL A - Load and Voltage Selector

This switch selects any one or a combination of loads and plate potentials applicable to the particular tube under test. In addition Control "A" serves as the function selector for Dry Battery testing.

CONTROL B - Filament voltage selector: Provides a complete range of 17 filament operating potentials from .75 through 117 volts. Control "B" also functions as DRY BATTERY TEST RANGE SELECTOR when switch "A" is set to "BATTERY TEST" position.

CONTROL C - Meter sensitivity potentiometer: A special, tapered potentiometer enabling the setting of calibration limits for all tubes as noted on the tube test roller chart.

ELEMENT DISTRIBUTION LEVER SWITCH

This distribution lever switch consists of 10 individual 4 position switches. Each switch is individually numbered from 1 through to 10. Each number represents a tube element number as listed by Tube Manufacturers and the Radio Manufacturers Association. For example, consider the case of a screen grid tube type 6SJ7. The tube element numbering, as listed in standard tube manuals, is as follows:

- Pin 1 - No Connection
- Pin 2 - Heater
- Pin 3 - Suppressor
- Pin 4 - Control grid
- Pin 5 - Cathode
- Pin 6 - Screen grid
- Pin 7 - Heater
- Pin 8 - Plate

When a type 6SJ7 tube is inserted into its socket, pin 1 of the tube is automatically connected to lever 1; pin 2 to lever 2; pin 3 to lever 3; etc. Each numbered lever, therefore controls the application of its corresponding tube element into the appropriate tube tester circuit. It will be noted that each Master Lever can be thrown into any one of 4 positions, indicated as: "D", "E", "F", and "NORMAL". The purposes of these positions are listed as follows:

Position "D" - Filament Return Position. Any lever thrown to the "D" position connects its corresponding element (usually one filament termination) to the filament potential selected by Switch "B"

Position "E" - Open Circuit Position. Any lever thrown to the "E" position open-circuits its corresponding tube element.

Position "F" - "TEST" or Cathode Conductance Test and meter indicating circuit. For the normal cathode conductance tube test, all tube elements other than those included in the filament-cathode circuit are thrown to "TEST" position; in the case of 6SJ7 therefore levers 3, 4, 6 and 8 are thrown to "F" position.

Position "NORMAL" - Common termination to cathode and/or reference potential.

It is therefore seen that the complete settings for the lever switches are as follows:

"D" (Fil. Ret)	"E" (Open)	"F" (Test)
7	-	3-4-6-8

NOTE: - All other levers remain in "NORMAL" Position.

In addition the lever switches serve as the "Short" and "Filament Continuity" test system. (See section C - "General Operating Instructions".)

"READ METER" BUTTON. This push-button (when depressed) provides the meter reading for Cathode Conductance quality tests.

"OFF" BUTTON. This push-button (when in the down or depressed position), shuts the instrument OFF. To turn the instrument ON, the "READ METER" button is depressed, releasing the "OFF" button.

SOCKETS:

This instrument incorporates the new Noval 9 pin, 8 contact acorn, loktal, combination 7 prong, Button 7 pin, 6 prong, 5 prong and 4 prong sockets. A "SPARE" socket is also incorporated providing accessible panel space for innovations in tube basing design.

OVERHEAD CONNECTOR CAPS ("Grid Caps")

Three separately functioning grid caps are employed:

1. BLACK DUAL CAP (accommodates both large and small type tube-caps), is used for all single capped tubes other than pin type caps.
2. RED DUAL CAP (accommodates both large and small type tube-caps), is used only in conjunction with tubes having 2 caps (such as type 2C22) OR in accordance with special instructions (roller chart).
3. SMALL BLACK PIN CAP. Used in conjunction with acorn type tubes and others incorporating similar pin type caps.

THE METER employed is of rectangular, modern design, incorporating a ruggedly constructed, D'Arsonval type movement of 2% accuracy. Tube performance Merit is read directly on two non-confusing multi-colored arcs supplemented by a linear reference scale for tube-matching purposes.

"TUBE-SPEC." SWITCH: This switch, in the "TUBE" position adjusts the short check circuit sensitivity in conformity with recommended practice. In the "SPEC." test position, extra-high sensitivity is provided for special purpose tube selection and qualitative check of paper condensers

THE PILOT LIGHT TEST SOCKET located incenter of combination 7 prong socket, accommodates all miniature screw and bayonet base pilot lamps.

FUSE EXTRACTOR POST; This post accommodates a type 3AG, 1 ampere fuse, conveniently replaceable from front of panel.

NOISE TEST PIN JACKS; These jacks provide for audible tube noise tests.

NEON LAMP SHORT INDICATOR (A sensitive GE type NE-57) is incorporated in a low electrostatic attraction short and filament continuity test circuit.

CONDENSER TEST TIP JACKS: These tip jacks provide for qualitative paper condenser tests and general continuity checking by the neon lamp method.

ROLLER CHART: The double-window, brass geared, tube-test data roller chart, (rotated through use of the thumb-actuated roller wheel) provides for trouble-free rapid access to all standard tube test settings. See back of instruction manual for test data covering special purpose tubes and tube types infrequently encountered.

C. GENERAL OPERATING INSTRUCTIONS

With "OFF" button depressed, connect the attachment plug of the instrument to any 50-60 cycle 110-125 volt A.C. source.

RETURN ALL LEVERS TO THE "NORMAL" POSITION.

Refer to the tube test roller chart for the tube test number to be tested and set only CONTROLS "A", "B", and "C", and the Lever designated under position "D" to position(s) indicated the roller chart.

Press (and then remove finger from) the "READ METER" button to turn instrument ON. (It noted that the "OFF" button is thereby released to the up or ON position.) Then rotate the "LINE ADJUSTMENT" control knob to bring pointer of meter to the vertical "ADJUST LINE" INDICATION.

NOTE: "ADJUST-LINE" indication will be had on the meter ONLY when control "A" is set to one of the tube test positions 1 through 5.

Insert tube to be tested into its respective socket and allow the tube to heat. (Use black or pin type overhead cap connector when necessary.) See Page 3 for use of RED cap connector. any deviation of the meter pointer from the "ADJUST LINE" position (after tube has heated) should be corrected by rotating the "LINE ADJUSTMENT" knob to bring the meter pointer back to "ADJUST LINE" position (center of scale).

FILAMENT CONTINUITY, HOT CATHODE LEAKAGE AND INTER-ELEMENT SHORT TESTS.

After settings are made (as noted above) WITH ALL LEVERS in the "NORMAL" POSITION (except the lever(s) which has been thrown to "D" position) and with the "TUBE-SPEC" switch in "TUBE" position, then proceed to obtain these tests by simply individually throwing the numbered levers 1 through 10, to position "F" and then back to "NORMAL" in consecutive order. Watch the neon lamp "SHORT" indicator for glow or continuous flicker as each lever is thrown into "F" position. The tube under test should be LIGHTLY tapped during "SHORT" tests, to reveal loose elements which might become shorted under vibration.

IMPORTANT: NEON LAMP SHOULD GLOW ONLY WHEN THOSE LEVERS DESIGNATED ON TUBE CHART FOR FILAMENT CONTINUITY, ("FIL. CONT.") ARE ACTUATED, OR ON THOSE ADDITIONAL LEVER NUMBERS SPECIFICALLY NOTED ON THE ROLLER CHART.

Inasmuch as the filament of the tube under test is disengaged when the "Fil.Cont" lever(s) (designated on the roll chart) is actuated for "SHORT" tests, it is necessary that this lever(s) be immediately returned to "NORMAL" position thereby allowing the tube to remain in a heated condition for further test.

The tube under test should be rejected as defective (open filament) if neon lamp fails to glow when the designated Filament Continuity lever(s) is actuated.

\* \* \* \* \*

DISREGARD ANY MOMENTARY NEON LAMP FLASHES AS LEVERS ARE ACTUATED.

These flashes are merely the discharge of the blocking condenser in the short check circuit

\* \* \* \* \*

NOTE: Inasmuch as the lever numbers directly coincide with socket prong numbers, it becomes apparent that the operator (for short check purposes) need only actuate that quantity of levers equal to the number of socket prongs involved. For example: If tube under test inserts into the 4 prong socket, then only levers 1 through 4 need be short-checked; if the tube inserts into the 5 prong socket, then levers 1 through 5 are the only ones involved, etc. If a top grid cap is present, then add lever 9 to the short check procedure.

A discernible neon lamp glow or continuous flicker, when any one of the levers "1 to 10" are actuated, (with the exception of the designated filament continuity lever) indicates an inter-electrode high resistance leakage or short and the tube should be rejected without further testing (unless otherwise noted on the tube test roller chart.) Inasmuch as these tests are made while the tube is in a heated condition, the tube should be allowed time to heat up sufficiently. In this manner, shorts or leakages that may occur due to expansion of internal elements can be more readily detected.

Because all tube elements connect to individually numbered lever switches, there is no necessity to employ a separate cathode leakage lever. Cathode leakage will be detected when the respective lever (corresponding to a particular tube's cathode), is actuated.

NOTE: Levers 1 through 10 are numbered in accordance with standard tube basing sequence. Should short indications be obtained on any one or more levers, (for example levers 5, 6 and 8), then the tube elements, corresponding to the tube pins No. 5, 6 and 8 are either internally shorted or are connected through low leakage paths to other elements of the tube.

AUDIBLE NOISE TEST.

An audible noise test of defective and noisy tubes can be had, if desired by inserting an earphone or audio amplifier system into the "NOISE TEST" tip jacks. The testing procedure is the same as outlined for obtaining HOT CATHODE LEAKAGE TESTS AND HOT INTER ELECTRODE SHORT TESTS described previously.

An intermittent or constant LOUD audible hum when making CATHODE LEAKAGE AND HOT INTER-ELECTRODE SHORT TESTS, will indicate loose or shorted tube elements, a possible cause for fading and noisy radio reception. A loud audible hum when the "FIL. CONT." lever is actuated is normal and is indicative of a continuous filament.

DO NOT ATTEMPT TO OBTAIN TUBE QUALITY METER INDICATION UNTIL AFTER SHORT TESTS ARE MADE, ELSE SERIOUS DAMAGE MAY RESULT TO INSTRUMENT.

TUBE QUALITY INDICATION (CATHODE CONDUCTANCE TESTS)

AFTER SHORT AND FILAMENT CONTINUITY CHECKS AND LINE ADJUSTMENTS HAVE BEEN ACCOMPLISHED, throw the levers indicated (on the roller chart) under "E" and "F" to the positions called for. ALL OTHER LEVERS (with the exception of the lever listed under position "D" which has already been thrown to its proper position in the FIL. CONT. test) MUST REMAIN IN "NORMAL" POSITION.

Then depress the "READ METER" button and obtain the (Cathode Conductance) Quality Indication.

IMPORTANT NOTE: ALL DIODES, diode sections of multi purpose tubes and special tubes indicated on the roller chart are checked on the two colored arc marked "DIODES-SPECIAL".

NOTE: The flexible element selection circuit of the SERIES 612 and 614 allows for either series or parallel connection of center-tapped filaments. In order to obtain uniformity of test settings and to minimize operating errors, all tubes with center-tapped filaments are tested in parallel connection. Should the neon lamp fail to glow when any one of the levers (listed on the roller chart under "FIL. CONT.") are actuated during the "FIL. CONT." test, the tube should be discarded.

If, however, one section of a center-tapped filament be indicated to be open-circuited, and for some reason the operator does perform a Quality Test, it will be found in many cases that a reading in the upper section of the red, "REPLACE" sector can be obtained. This is, of course, due to the parallel filament connection. The intact portion of the filament is still operating and causing a partial meter reading to be obtained. Such tubes should have been previously discarded as the result of the "FIL. CONT." test failure.

OPEN ELEMENT TESTS:

Should the Cathode or Control grid of a tube to be tested, be open circuited within the tube (an unusual occurrence) a "REPLACE" indication will automatically be obtained during the Quality Test. Should the relatively rare condition of an open circuited Screen or plate, etc. occur, the condition may be ascertained during the Quality Test by holding the "READ METER" button down and individually throwing the levers under "F" position on the roller chart to "E" position and then back to "F" position. If an element is open circuited NO movement of the meter pointer will be noted as its corresponding numbered lever is actuated

SPECIAL ROLLER CHART NOTATIONS

"EYE TESTS" (electron ray type indicator tubes)

Single Target Type. This type is typified by types 6E5 and 6G5: For example a roller chart line for type 6E5 appears as follows:

TUBE	SECTION	A	B	C	D	E	F	Fil. Cont.
6E5	Eye	4	7	0	1	-	2-4	-

The following test procedure must be employed: After performing the standard "SHORT" test, set all switches and levers as indicated on the roller chart. Depress the "READ METER" button and observe the circular fluorescent screen which should illuminate completely.

Next, throw the FIRST of the two levers indicated under the "F" lever setting (in this example, lever 2) TO THE "NORMAL" POSITION.

A good tube will now exhibit a typical angular shadow. Return the same first

lever to its original "F" position and note closure of the shadow angle. DISREGARD METER INDICATIONS.

Double Target Type. (Twin electron ray indicator tubes)

This type is typified by type 6AF6 and 6AD6; For example, a typical roller chart line for type 6AD6 appears as follows:

TUBE	SECTION	A	B	C	D	E	F	Fil. Cont.
6AD6	Eye	4	7	0	2	-	3-4-5	7

The following test procedure must be employed:

After performing the standard "SHORT-TEST", set all switches and levers as indicated on the roller chart.

Depress the "READ METER" button and observe the circular fluorescent screen which should illuminate completely.

Next, throw the FIRST of the three levers under the "F" settings (in this example, lever 3) to the "NORMAL" position. A good tube will now exhibit a typical angular shadow.

Next throw the SECOND of the three levers under the "F" settings (in this example, lever 4) to the "NORMAL" position. The tube, if good will exhibit another angular shadow opposite the position occupied by the first shadow. DISREGARD METER INDICATIONS.

FM/AM Eye Tests (Tuning indicator tubes). This type of electron ray tube is typified by type 6AL7 and is tested simply and positively through virtue of the flexibility of the Series 612 and 614.

Test procedure is as follows:

After performing the standard "SHORT" test set all levers and switches as indicated on the roller chart including the lever numbers listed in the parenthesis.

Depress the "READ METER" button and observe the two rectangular fluorescent patterns on the screen of the tube.

With the "READ METER" button depressed throw the FIRST lever listed in the parenthesis from its "D" position to "E" position. One rectangular pattern should become slightly shorter in length.

Next, throw the SECOND lever listed in the parenthesis from its "D" position to "E" position. The other rectangular pattern should then become shorter in length.

Next, throw the THIRD lever listed in the parenthesis from its "D" position to "E" position. BOTH ends of the pattern (opposite to the ends noted above) should then slightly decrease in length. Observe these ends closely as the movement may be slight.

SPECIAL RECTIFIER TEST (types 70A7, 117N7 and 117P7)

Because of unusual internal connections (plate tied to one side of filament) the 70A7, 117N7 and 117P7 RECTIFIER sections require slightly special test procedures.

70A7 - RECTIFIER SECTION. Set all controls and lever 2 in accordance with the roller chart. AFTER THE TUBE HAS HEATED SUFFICIENTLY throw BOTH levers 2 and 7 rapidly to "E" position and then lever 6 rapidly to "F" position - then quickly depress the "READ METER" button. The first meter deflection obtained is the significant reading, inasmuch as the meter reading will quickly recede coincidental with cooling of the heater.

117N7 and 117P7 - RECTIFIER SECTION. Set all controls and lever 2 in accordance with the roller chart. All levers, with the exception of lever 2, must be in "NORMAL" position, AFTER THE TUBE HAS HEATED SUFFICIENTLY, throw lever 2 rapidly to "E" position AND lever 7 rapidly to "F" position, then quickly depress the "READ METER" button. The first meter deflection obtained is the significant reading, inasmuch as the meter reading will quickly recede coincidental with cooling of the heater.

SPECIAL SHORT INDICATION NOTES. Listings for several tubes on the roller chart bear notes indicating that certain tubes "Must Show Short" on one or more levers in addition to the "FIL. CONT." numbers. For normal usage any tube which does not show short on the designated levers should be considered a defective tube.

However due to multiple terminations of elements in many modern tubes, certain of these tubes may be salvaged for specific applications wherein the exact circuit application is known. Two of these cases are noted as follows:



- a) Tubes with the negative filament connection terminating in 2 base pins. Should one of the two base pin connections become open, the tube may be salvaged and the remaining pin may be used for negative filament termination only if the radio or electronic circuit will allow the use of that pin or BOTH.
- b) Tubes with an element such as plate, grid, etc. terminating at two or more base pins. Again, if one terminating pin remains connected to the element, the tube may be salvaged if the electronic circuit will allow the use of that pin and does not require the use of the open-circuited base pin or BOTH.

Gas Type Rectifiers OY4, OZ3 and OZ4

When testing these gas rectifier types, it will be noted that the meter pointer will remain, for a short interval, in the "REPLACE" sector and then deflect rapidly into the "GOOD" sector. This condition is normal for a good gas rectifier. However, should the meter pointer remain constantly in the "REPLACE" sector (after the lapse of several seconds), then the gas rectifier should be rejected.

SUB-MINIATURE TUBE TESTS

The sub-miniature type of vacuum tube, (typified by types 1C8 and 2E31) employs closely-spaced flexible leads for element terminations in contrast to standard rigid pin basing. In addition, two bulb shapes are in production; The ROUND type with lead terminations arranged circularly, and the FLAT type with lead terminations arranged in one linear plane. Considering this condition and the fact that many subminiature types are directly soldered into operating circuits, with leads cut to varying lengths, PRECISION engineers offer a simple but FLEXIBLE AND UNIVERSAL subminiature tube test adapter unit with flexible leads and positive contact clips. This adapter unit permits positive connection of sub-miniature tubes with maximum facility regardless of lead length variations, and with a minimum possibility of inter-lead shorting. See Fig. 1. below.

This adapter, Precision No. G-110 is available as a separate optional item in view of its specialized and limited application.

Adapter G-110 can be obtained directly from distributor or factory, at nominal cost. It can also be readily fabricated from standardly available parts through reference to Fig. 1. Each lead is numbered 1 through 8 in accordance with the standard basing of the octal plug.

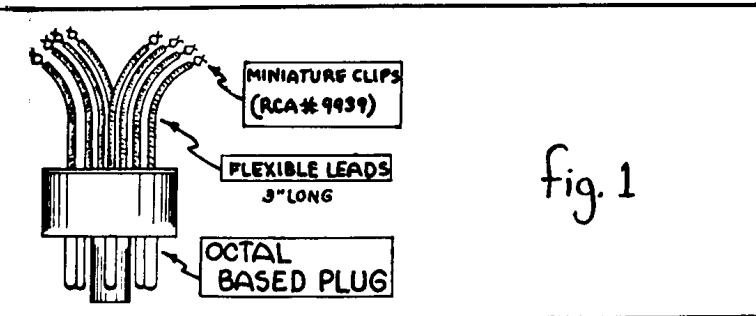

TUBE-BRAND VARIATIONS.

In determining the tube test limits for this instrument, PRECISION engineers have spent considerable time checking thousands of tubes from the production runs of leading tube manufacturers. From the information so gathered, the data on the roller chart, accompanying this instrument, has been compiled.

Inasmuch as extensive and intensive research is constantly being made in the radio tube industry to improve and stabilize the electrical and mechanical construction of tubes, it is not uncommon for a tube manufacturer to make a change in a particular tube's specifications. This change, though not necessarily readily noticeable in radio set performance, may nevertheless be made to improve tube stability and life. This change or variation may, however, indicate itself on the PRECISION Series 612-614 and necessitate a new test limit for that particular type number.

Therefore, should a particular type number be found to vary consistently from the assigned average roller chart limits, merely redetermine the new CONTROL "C" average setting required to pass these tubes at approximately 70 of the 0-100 linear scale below the 3 color tube testing arc.

It can readily be seen that a consistently low or high reading for any particular tube type of a definite manufacturer is not necessarily to be taken as indicative of a poorer or better run of tubes, nor as defect in the tube tester.

PILOT LAMP TESTS

The miniature base socket, located in the center of the combination seven prong tube socket accommodates all miniature screw and bayonet base type pilot lamps, Christmas tree bulbs, etc. Test procedure is as follows:

a) Select proper filament voltage by setting CONTROL "B" to one of the following applicable voltages:

<u>CONTROL "B"</u>	<u>VOLTS</u>	<u>POS.</u>	<u>VOLTS</u>	<u>POS.</u>
	.75	1	10	9
	1.5	2	12.6	10
	2.0	3	18.9	11
	2.5	4	25	12
	3.3	5	35	13
	5.0	6	50	14
	6.3	7	70	15
	7.5	8	85	16
			117	17

b) Set Lever #1 to position "D"; turn instrument "ON"; adjust for "LINE"; insert bulb. NOTE: LEVER SWITCHES 2 THROUGH 10 MUST BE IN "NORMAL" POSITION.

D. BALLAST INFORMATION

BALLAST TESTING:

The neon short check circuit, in conjunction with the numbered Lever-Distribution system provides a simple and positive method for obtaining the following ballast tests.

1. Point to point continuity test of each section of single unit as well as multiple section ballasts.
2. Tests for loose elements.
3. Tests for leakage between sections of multi-element ballasts.

NOTE: Frequently, one may encounter privately numbered ballast tubes, whose numbers have no relationship to the standard RMA Ballast Coding System. A uniform method of ballast resistor test can only be devised on the basis of some type of system. The "Precision" ballast test data, which follows, is related to the Standard RMA Code. Therefore, privately numbered ballasts should be referred to ballast manufacturers' replacement manuals for identification of the ballast in terms of the Standard RMA Code.

BALLAST RESISTOR CODE:

A sample and interpretation of the code appearing on standard octal type and replacement type ballasts are as follows:

(RMA STANDARD OCTAL TYPE) BK49AG  
 (REPLACEMENT TYPE) BKX55AG

The first letter "B" on both types, if used, indicates ballast action. The letter "K", "L" or "M" on both types, indicate type of pilot lamp. The letter "X", "Y" or "Z", immediately following the pilot lamp designation, denotes a particular SERIES of base wiring and appears only on replacement type ballasts. The numerals "49" or "55", appearing on the respective types, indicate the total voltage drop produced by the ballast resistor including the pilot lamp. The letter "A" or B-C-D-E-F-G-H-J, appearing on both types (and immediately following the voltage drop numerals) designates the particular BASE WIRING Circuit used. The letter "G" following the base wiring circuit designation on both types, if used, merely indicates octal base glass unit, and is of no importance as far as testing is concerned.

A letter "J" following the base wiring designation such as K55CJ, refers to an internal jumper between pins 3 and 4, (See BALLAST TEST PROCEDURE).

Where the letter "p" or "PR" appears after the base wiring designation, such as K55CP or K55CPR, this indicates an additional resistor section is employed for the rectifier plate circuit (See BALLAST TEST PROCEDURE).

FOR STANDARD RMA OCTAL TYPE BALLASTS, THE BASE WIRING DESIGNATION A-B-C-D-E-F-G-H-J IS THE ONLY INFORMATION NECESSARY FOR TEST PURPOSES.

FOR REPLACEMENT TYPE BALLASTS, THE X, Y, OR Z SERIES AND BASE WIRING DESIGNATION IS THE INFORMATION NECESSARY FOR THE TESTING OF THESE TYPES.

BALLAST TEST PROCEDURE:

The OCTAL SOCKET is used to accommodate all octal base type ballasts.

1. ALL CONTROLS AND LEVERS MUST BE IN THE FOLLOWING DESIGNATED POSITIONS BEFORE ANY ATTEMPT IS MADE TO TEST BALLAST UNITS:

Set CONTROL "A" to #1 position  
 Set CONTROL "B" to #18 position  
 Set CONTROL "C" to 0 Position  
 Throw all levers to "NORMAL POSITION"

2. Turn instrument ON and adjust for "ADJUST-LINE" indication on the meter. Insert the Ballast.
3. Classify the BALLAST unit to be tested according to its R.M.A. Base wiring. Refer to Fig. 1 below and determine the applicable base pin numbers. Then individually throw the levers corresponding to the base pin numbers, to "F" position and then back to "NORMAL" position. A neon glow should be obtained as each lever is thrown to "F" position.

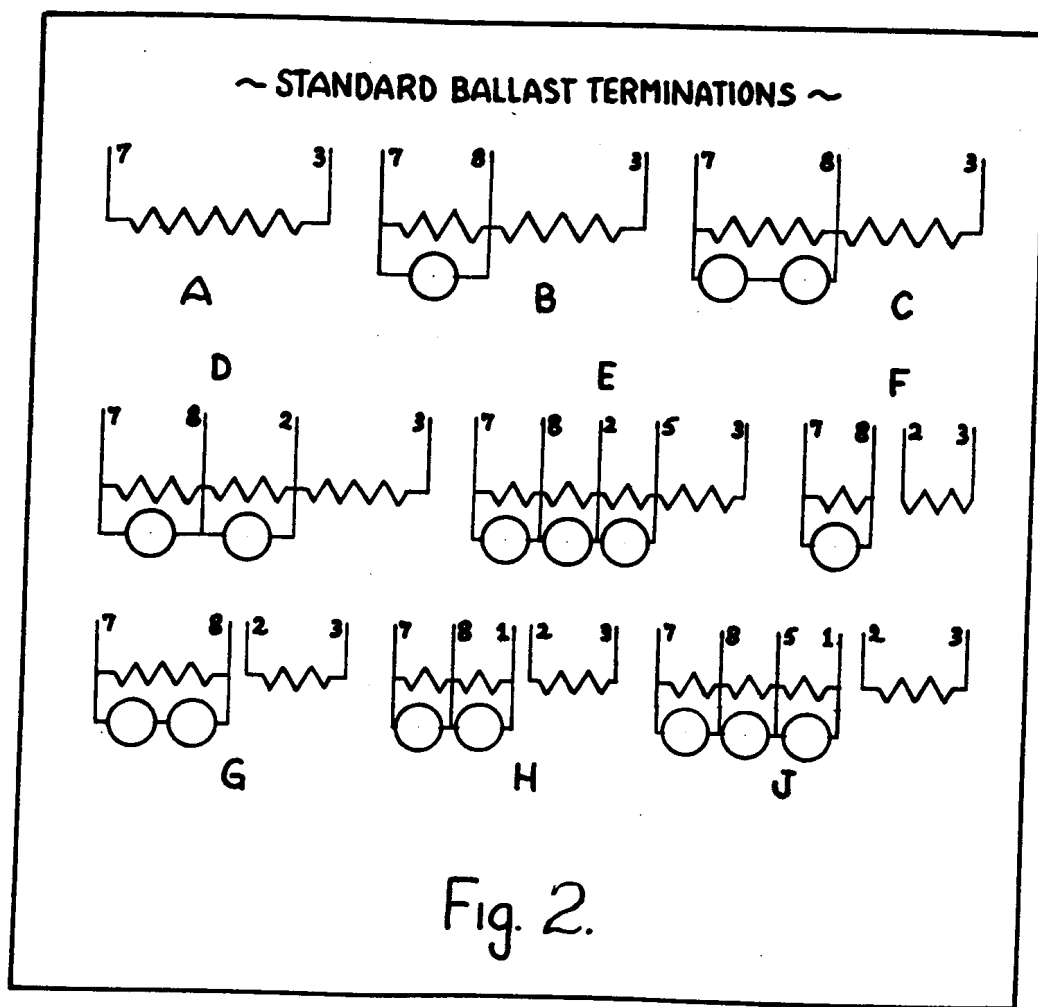

For example, Ballast type BK86A is an "A" type base wired unit. It is checked by referring to diagram "A" of Fig. 2, which reveals that lever 3 must be thrown to "F" position and then back to "NORMAL" position. Lever 7 must then be similarly actuated.

Neon lamp should glow as each of these 2 levers is thrown to "F" position. Should the ballast incorporate a jumper (for example from pin 3 to pin 4 as for ballast designation BK86AJ) neon glow must also be obtained when lever 4 is thrown to "F" position.

CAUTION: NEVER DEPRESS "READ METER" BUTTON DURING BALLAST TESTS.

4. A continuous neon lamp glow, as each numbered lever (called for) is thrown to "F" position, indicates that the section is not open circuited. An open section (anywhere in the chain) will cause the neon lamp to extinguish when that section's numbered lever is thrown to "F" position.

It is advisable to tap the ballast unit while each lever (called for) is being actuated. In this manner, loose elements can be ascertained by noticing flickering instead of continuous glow of the neon lamp.

**NOTE:** Where letter "P" or "PR" follows the base wiring designation, such as BK86 or BK86APR, then it is also necessary to actuate lever 5, in addition to the levers required for the base wiring code "A".

**LEAKAGE TESTS;** Tests for leakages between sections of multi-section ballast units having BASE WIRING designations "F", "G", "H" or "J" are accomplished by throwing BOTH levers 2 and 3 to "F" position (simultaneously), with all other levers remaining in the "NORMAL" position. A neon lamp glow (if obtained) will indicate leakage or short between the two independent sections, and the ballast unit should be rejected as defective.

If any special ballast resistors are ever encountered (which cannot be identified with any standard RMA Coded basing), then merely determine the internal wiring from a service manual schematic and proceed as outlined for all ballast continuity checks.

#### E. QUALITATIVE PAPER CONDENSER TESTS

The jacks marked "COND. TEST" are used to obtain paper condenser tests by the sensitive neon lamp method. The self-contained power supply applies the necessary rectified voltage to the paper condenser.

##### PROCEDURE:

1. Connect instrument to power line and turn instrument "ON".
2. Set the "TUBE-SPEC." Switch, to "SPEC." position. (High sensitivity position)
3. With CONTROL "A" set to #1 position, rotate "LINE ADJUSTMENT" knob to obtain "ADJUST-LINE" indication on meter.
4. Insert test leads into the "COND. TEST" jacks. Apply the free ends across the paper condenser to be tested and observe the indications of the neon lamp.
  - a) A steady glow indicates a low D.C. resistance or short circuited condenser
  - b) A continuously flickering neon glow indicates a high resistance leakage condition.
  - c) No indication of neon lamp indicates that the condenser under test is either open or the capacity is too small to cause the neon lamp to register visibly.
  - d) A good condenser will cause a momentary neon lamp flash, the duration of which is dependent upon the capacity being checked. The greater the capacity, the longer the duration and vice versa.

Polarity need not be observed when testing paper condensers.

#### F. BATTERY TESTING INSTRUCTIONS

The PRECISION Series 612-614 Tube and Battery Testers incorporate a highly efficient, DIRECT READING, Dynamic battery performance testing circuit, developed and designed by PRECISION engineers.

Stressing extreme simplicity in both operation and readability, the PRECISION battery performance test circuit, nevertheless, DIRECTLY accommodates ALL POPULAR dry batteries including portable-radio "A", "B" and "C" batteries, from 1.5 through 135 volts.

Through the use of a specially designed switching circuit, each battery is TESTED UNDER LOAD simulating operating conditions, which the battery may be required to serve in a receiver. The load conditions ARE NOT ARBITRARILY CHOSEN. The same basis applies to the calibration of each range, so that batteries will definitely be rejected when their LOADED terminal voltage no longer comes up to the stability requirements of good radio reception or similar usage.

HOW TO TEST BATTERIES

ALL SELECTORS MUST ALWAYS BE SET TO THEIR APPROPRIATE POSITIONS BEFORE MAKING ANY BATTERY TESTS.

1. Set Selector Switch "A" to "BATTERY TEST".
2. Selector "B", in addition to its functions in the tube testing circuit, serves as the combination voltage and load selector for battery testing, and is set to its required positions as follows:

Pos. #1 - 1.5 volt batteries	Pos. #7 - 15 volt batteries
" #2 - 3 " "	" #8 - 22.5 " "
" #3 - 4.5 " "	" #9 - 30 " "
" #4 - 6 " "	" #10 - 45 " "
" #5 - 7.5 " "	" #11 - 67.5 " "
" #6 - 9 " "	" #12 - 90 " "
	" #13-135 " "

Once Control "A" is set to "BATTERY TEST", Selector "B" is the ONLY switch whose setting changes for batteries of different voltages. No other switch or controls are associated with battery testing.

3. Insert test leads into (-) and (+) "EXTERNAL TEST" pin jacks and apply test probe (in proper polarity) directly across appropriate terminals of battery under test (\*). The meter will immediately indicate the performance condition of the battery on the wide 3 colored "REPLACE - ? - GOOD" scale.

\* CAUTION: IN THE EVENT THAT BATTERY TERMINALS ARE NOT IDENTIFIED AS TO POLARITY OR VOLTAGE, ALWAYS FIRST REFER TO RECEIVER OR BATTERY MANUFACTURERS' DATA SHEETS FOR THE NECESSARY INFORMATION BEFORE TESTING, TO AVOID THE POSSIBILITY OF OVERLOADING AND DAMAGING THE METER.

Batteries reading in the RED "REPLACE" sector should immediately and unquestionably be replaced. (Read on large 3 colored arc)

Batteries reading in the YELLOW "?" sector, although normally still capable of use for a short period of time, should also be replaced. Weak batteries are known cause of slow "fade-outs", drift and other receiver instabilities.

NOTE 1. When testing batteries used in test equipment ohmmeter circuit the battery may test "GOOD" and nevertheless, not give full scale meter deflection in the ohmmeter circuit. This is simply explained by reason that the rejection point of ohmmeter batteries is usually considerably above that for receivers, test oscillators and similar devices. Accordingly, as far as ohmmeters are concerned, a battery is considered unuseable when full scale ohmmeter adjustment can no longer be obtained in the particular tester in which it is employed, as described by the test equipment manufacturers.

This same battery, if it reads "GOOD", may yet nevertheless furnish some additional service in a portable radio, though, of course, its remaining useful life is considerably below that of a brand new battery, as its position on the battery test "GOOD" scale will indicate.

NOTE 2. All new batteries, regardless of voltage type, will, when new and with the proper "B" setting, read at approximately the 70% indication on the 0-100 scale. SOME LITTLE VARIATION IS TO BE EXPECTED BETWEEN BATTERY BRANDS. Because one brand of new battery may read a little higher than another, it is not an indication of a superior battery. This is attributable to certain initial chemical conditions within the battery, and in service will all average around the same operating point.

G. SERVICE DATA

The PRECISION SERIES "600" test instruments have not only been designed to accurately indicate the merit of vacuum tubes, but have been constructed to withstand the abuses of general field use. All components have been exhaustively sample-tested by Precision's Test Engineering Laboratory and have been approved for general long-life usage. Generous mechanical design is a major Precision precept.

However . . . . It is impossible to fully control the two major contributions to operative instruments namely:

- 1) Failure of components after instruments have passed Precision's Performance Test Department and
- 2) Damage of components due to misoperation, accidental or otherwise, including failure to OBSERVE PRESCRIBED OPERATING PROCEDURES.

Therefore, in order to expedite rehabilitation of your instrument, (should the need arise), the most commonly encountered possible failures and recommended remedial measures therefor are listed as follows:

IMPORTANT NOTE: Your PRECISION SERIES 612-614 is a relatively complex instrument, and has been carefully inspected and calibrated by Precision's Performance-Test Department. - - DO NOT attempt repairs or modifications other than those listed below unless upon specific recommendation by Precision's SERVICE DEPARTMENT.

1. Instrument does not become energized upon application of line voltage and release of "OFF" button.
  - a) Remove 3AG, 1 ampere fuse from panel mounted fuse holder. If blown, replace with same size and type fuse only if the cause for blowing of fuse is known and has been remedied.

Reasons for fuse-blowing may be:

Failure to short-check a tube before attempting quality test.  
Shorted power transformer windings or other internal shorts.

2. Several type tubes with the same "A" switch setting do not provide meter merit indications.
  - a) The load resistor associated with the particular "A" switch position may be open. Refer to the schematic, check the resistor with an ohmmeter. If open circuited, contact Precision's Service Department for a replacement Resistor.
3. Meter does not indicate "ADJUST LINE" check when instrument is energized.
  - a) Remove 5Y3 rectifier tube and replace if defective.
4. "Line" adjustment is erratic
  - a) Examine Line potentiometer item #R30 ("Line Adjustment") for shorted, open or worn turns. Unsolder the three leads and check for continuity with an ohmmeter. If defective, contact Precision's Service Department.
5. Erratic checks of several tubes with the same type base.
  - a) Examine that particular socket contact and check for being loose or broken. If new sockets are required, contact Precision's Service Department or your parts distributor.
6. Tubes with overhead caps check improperly.
  - a) Check cap leads for continuity especially at the cap end. Continuous use and attendant flexing of the wire occasionally cause breakage.
7. Improper operation of Battery Test at any one position of Switch "B":
  - a) Check Battery network resistors with an ohmmeter. Multiplier resistors associated with each position of switch "B" are mounted on Switch "B".
  - b) Should the meter read off-scale on "Battery Test" check shunt resistors R27, 28 and 29 for open circuit.

All replacement items are obtainable through contact with Precision's Service Department.
8. Apparent defective operation of the instrument meter.
  - a) Repair and recalibration of the meter of a Series 612-614 is a delicate and highly specialized operation. DO NOT ATTEMPT TO REPAIR AN INOPERATIVE METER. Always contact Precision's Service Department should your meter appear defective or damaged.

SPECIAL NOTE RE REPAIR SERVICE

When returning a Precision instrument for repair-recalibration service, ALWAYS pack carefully in a strong oversized corrugated shipping container, using a generous supply of padding such as excelsior, shredded paper or crumpled newspaper. The original container and filling pads (if available) are ideal for this purpose. Please ship via Railway Express PREPAID and mark for:

PRECISION APPARATUS COMPANY, INC.  
92-27 Horace Harding Blvd.  
Elmhurst, L.I., N.Y.

ATT: Service Division

FRAGILE label should appear on at least four sides of the carton.

Never return an instrument unless it is accompanied by full explanation of difficulties encountered. The more explicit the details, the more rapidly your instrument can be handled and processed.

H. GENERAL NOTES AND INFORMATION

1. The "Spare" SOCKET. In anticipation of unusual receiving type tube developments in the future, a "Spare" socket has been provided on the instrument panel. Available reserve panel space therefore awaits the insertion of unusual type tube sockets.
2. Roller Chart: New roller charts, including data for the latest type tubes, are printed periodically, and are issued free of charge, as a Precision service, upon individual request. It is VERY important that such requests list the following information:
  - a) Series No. (on panel or nameplate).
  - b) Serial number of instrument (on Nameplate)
  - c) FORM NUMBER OF YOUR PRESENT ROLLER CHART  
(printed at the upper left hand corner of every roller chart).
4. A guarantee-registration card is enclosed with this instrument. Mail card at once for registration.
5. Tube-Test Accessories Included:
  1. Instruction Manual
  1. Tube Test Roller Chart
  1. Type 5Y3 rectifier tube
  1. #40 6-8 volt pilot lamp
  1. #NE-57 neon lamp
  1. Registration card

\* \* \* \* \*

PRECISION APPARATUS COMPANY, INC.  
92-27 Horace Harding Blvd.  
Elmhurst, L.I., N.Y.  
U.S.A.

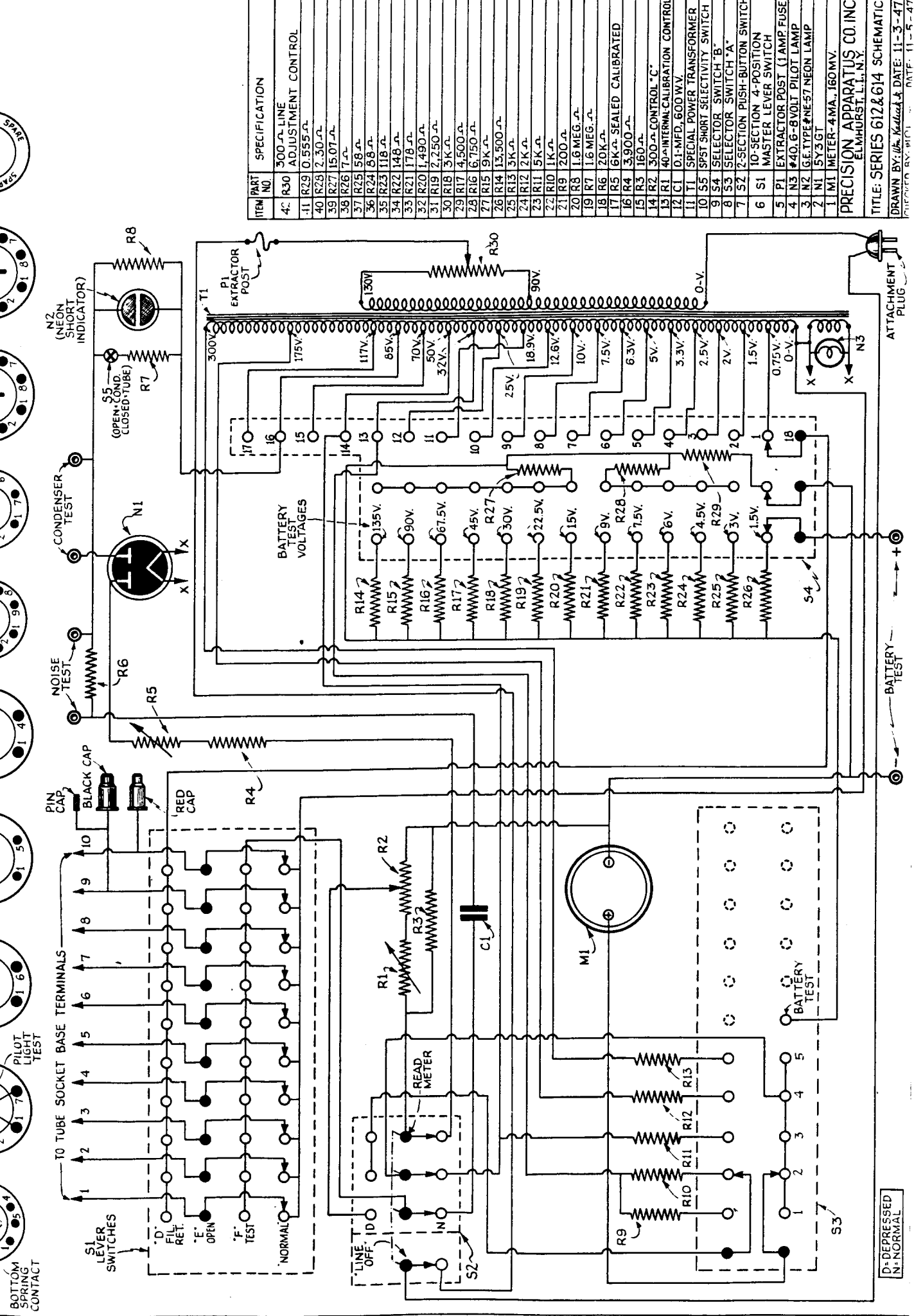
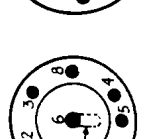
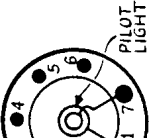
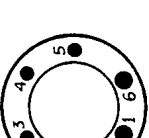
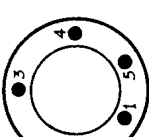
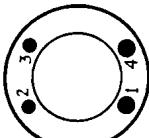
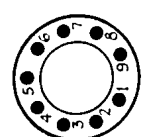
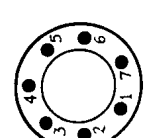
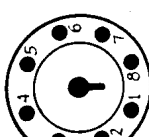
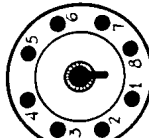
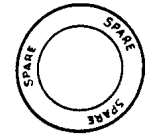

ITEM	PART NO.	SPECIFICATION
4C	R30	500 Ω LINE ADJUSTMENT CONTROL
11	R29	0.555 Ω
40	R28	2.30 Ω
39	R27	15.07 Ω
38	R26	7 Ω
37	R25	58 Ω
36	R24	88 Ω
35	R23	118 Ω
34	R22	148 Ω
33	R21	178 Ω
32	R20	1.490 Ω
31	R19	2.250 Ω
30	R18	3 K Ω
29	R17	4.500 Ω
28	R16	16.750 Ω
27	R15	19 K Ω
26	R14	13.500 Ω
25	R13	3 K Ω
24	R12	2 K Ω
23	R11	15 K Ω
22	R10	1 K Ω
21	R9	200 Ω
20	R8	1.6 MEG Ω
19	R7	1.6 MEG Ω
18	R6	20 K Ω
17	R5	6K Ω SEALED CALIBRATED
16	R4	3.900 Ω
15	R3	160 Ω
14	R2	300 Ω CONTROL "C"
13	R1	40 Ω INTERNAL CALIBRATION CONTROL
12	C1	0.1 MFD; 600 WV.
11	T1	SPECIAL POWER TRANSFORMER
9	S4	SELECTOR SWITCH "B"
8	S3	SELECTOR SWITCH "A"
7	S2	2-SECTION PUSH-BUTTON SWITCH
6	S1	10-SECTION 4-POSITION MASTER LEVER SWITCH
5	P1	EXTRACTOR POST (1 AMP FUSE)
4	N3	#40, 6-8VOLT PILOT LAMP
3	N2	G.E. TYPE #NE-57 NEON LAMP
2	M1	15Y3GT
1	M1	METER-4MA., 160MV.

TITLE: SERIES 612 & 614 SCHEMATIC  
 DRAWN BY: Wm. K. ... DATE: 11-3-47  
 CHECKED BY: W.C.L. DATE: 11-5-47  
 PRECISION APPARATUS CO. INC.  
 ELMHURST, L.I., N.Y.

D-DEPRESSED  
 N-NORMAL