

A Brasspounder Improves Heath's HR-1680

— add a crystal CW filter, bfo, noise blanker, and more

The Heathkit® HR-1680 is a distinct rarity: a ham-bands-only receiver in kit form for a tad more than \$200. It is a fine piece of equipment and is almost the answer for a low-budget station. Why almost? Low budget usually means CW using a homebrew or swap-meet-special

transmitter and low power at that. The SSB capabilities of the HR-1680 are good, but CW is sort of tacked on. What the HR-1680 needs is a narrow CW filter, and a bfo placed correctly for CW operation, and maybe even a noise blanker. It so happens that Heath makes these items

for other products in their line, and for a reasonable price.

I hate modifications that wreck the appearance of a piece of gear and reduce its resale value to zero. Many modifications not only prove to be far less useful than the author promises, but unfortunately, irreversible. This article describes how to add a crystal CW filter, bfo, noise blanker, and a couple of other worthwhile modifications to your HR-1680 without having to attack the set with drills, saws, and other sharp instruments. All modifications are reversible, require a minimum of rewiring, and the drilling of one little hole on one circuit board. Purists can attach the bfo board to the AUD/REG board with silastic rubber.

Modifications

The modifications will be presented in the following order:

- 1) changing the dial lamps to reduce voltage regulator heating; and to a type more readily available.
- 2) modification of the spinner knob for 1-kHz resolution;
- 3) addition of an SBA-301-2,

- 400-Hz crystal filter;
- 4) addition of a separate bfo for CW; and
- 5) addition of an SB-104-1, noise blanker.

The crystal filter and noise blanker are housed in a small utility cabinet (Radio Shack 270-253 is an ideal size), or they could be fitted into the HR-1681 speaker cabinet if desired. The bfo board is attached to the HR-1680's AUD/REG PCB. Total cost of all mods should be about \$75.

Pilot Lamps

At this writing, I have been using my HR-1680 for over two years without any component failures, and this mod may be due in part to something that annoyed me no end when I discovered it. The pilot lamps in the HR-1680 operate from the regulated supply. This represents two Watts of unnecessary power for the regulator series pass transistor (Q201) to handle, and causes its heat sink to reach to over 100°C after only a few minutes of operation. Besides, nobody seems to stock type 1813 bulbs.

The solution is simple: Disconnect the red wire supplying 13.8 volts to the

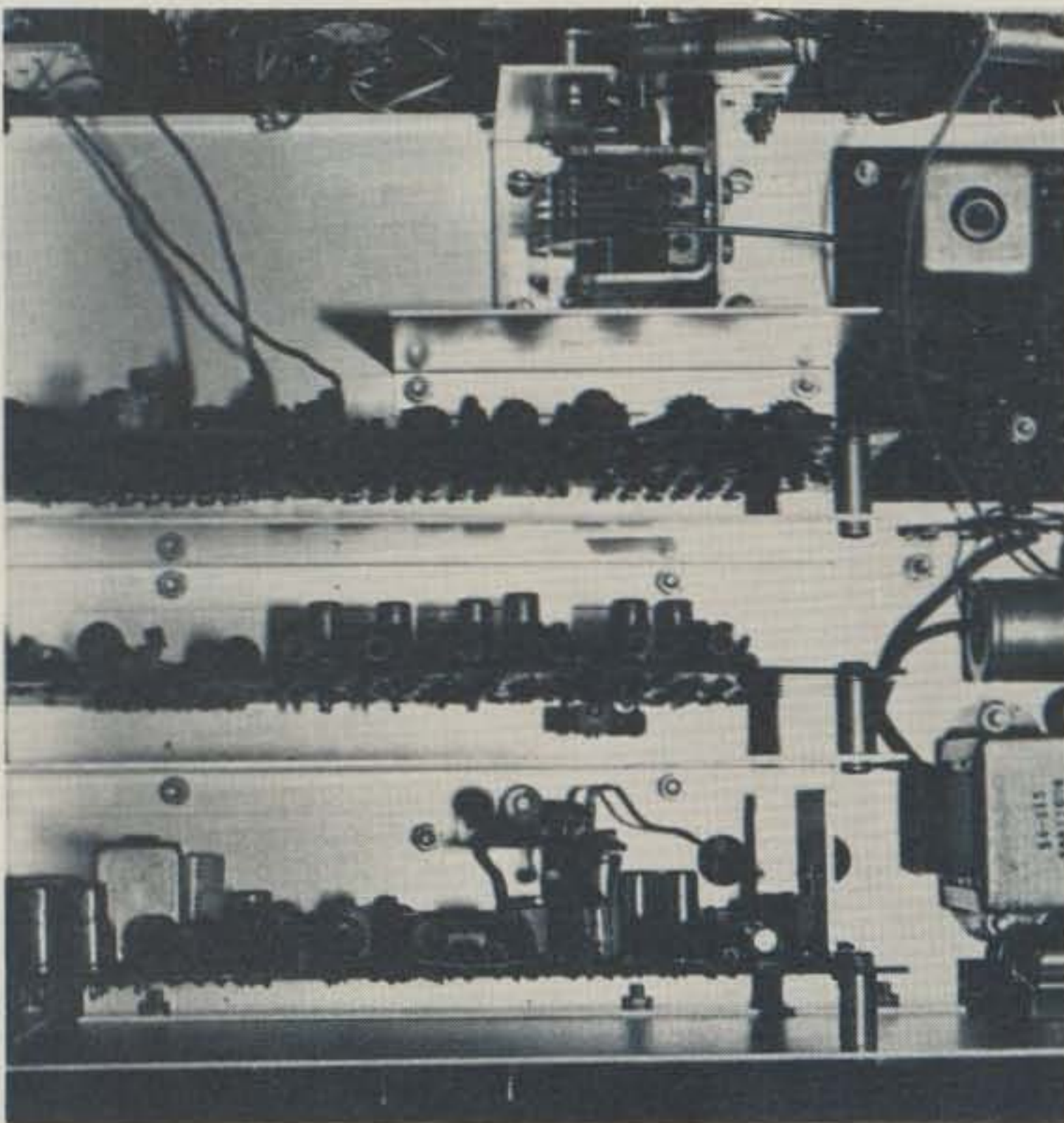

Photo A. Top interior view of the HR-1680 shows the new bfo board (near middle of bottom board) and new connecting wire to pilot lamps (upper right).

pilot lamps. Run a new wire across the top of the chassis and connect it to the junction of D1, D2, and C2 at one end and the lamp sockets at the other. Arch the wire up and over and avoid getting it too close to the vfo (see Photo A). Remove the two type 1813 bulbs and replace them with type 1819 bulbs (28 volts, 40 mA). The new lamps will provide just about the same amount of light, you will save 120 mA of total current, and the regulator will now operate at a reasonable temperature even when we borrow 50 mA to operate the crystal filter amplifier and the noise blanker.

A small drawback exists with this modification: The lamps won't light when external power is used. If you use external power very often, you might want to install some sort of switching arrangement. My feeling is that if you are really on emergency power, can you afford those wasted Watts? Buy a flashlight.

Spinner Dial

Another thing that bothered me about the HR-1680 was the dial calibration. When the vfo is

properly adjusted, the HR-1680's dial is reasonably linear, but there are calibration marks only at every five kHz. It seemed that the spinner knob could be inscribed to give at least one-kHz markers. I spent about a week of fooling around and gluing pieces of cardboard to the spinner. To spare you the cussin', I found that each revolution of the spinner was equivalent to 15.625 kHz or 23.04 degrees of arc per kHz. It does not take a mathematician to see that there is no way to calibrate the spinner in a whole number of one-kHz increments. After spending all that time, I was not about to give up. I removed the skirt from the spinner and glued a thin flat plate (a 3½-inch diameter dial plate from an old stereo receiver) to the back side of the spinner knob. I then scribed lines on the plate to make pies of 23.04 degrees, and when I ran out of plate, I stopped. I then filled the scribed lines with black ink and coated the plate with clear nail polish (acrylic spray made the ink run). Now the spinner is calibrated in one kHz in-



Photo B. Front view of modified HR-1680 (with completed filter-blanker on top) shows details of modified spinner knob.

crements with one .625-kHz increment left over. The construction sounds terrible, but it works fine. See Photo B.

Crystal Filter and Amplifier

Anyone who has ever operated CW must surely have desired "single-signal reception." The audio filter of the HR-1680 does not have anything like the needed selectivity. I feel sure that the people at Heath know this, but they

had to keep the price down. Heath makes two 400-Hz filters, the SBA-301-2 and the newer SBA-401-1. As far as I can determine, the filters are

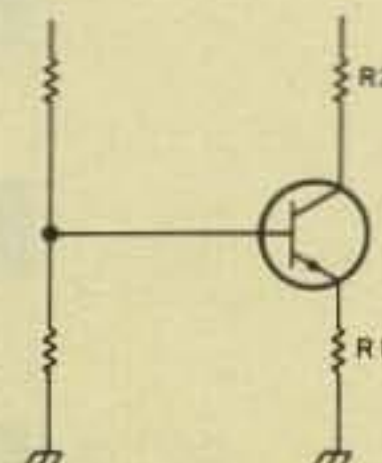

Fig. 2. In a common-emitter bipolar amplifier, the voltage gain of a stage with an un-bypassed emitter resistor is approximately the ratio of the collector resistor to the emitter resistor: $\text{Gain} \approx R2/R1$. This relationship holds over one or two decades (sometimes more) assuming that the gain of the transistor is adequate for the bandwidth of interest. As an example, consider a phase-splitter circuit where $R1 = R2$ and the gain is unity. In the amplifier used in this article, $R1 = 470 \text{ Ohms}$ and $R2 = 2200 \text{ Ohms}$. $R2/R1 = 2200/470 = 4.68$ or $4.68 \times 20 \log 10 = .670 \times 20 = 13.4 \text{ dB}$. Naturally, when 10% components are used the approximation suffers.

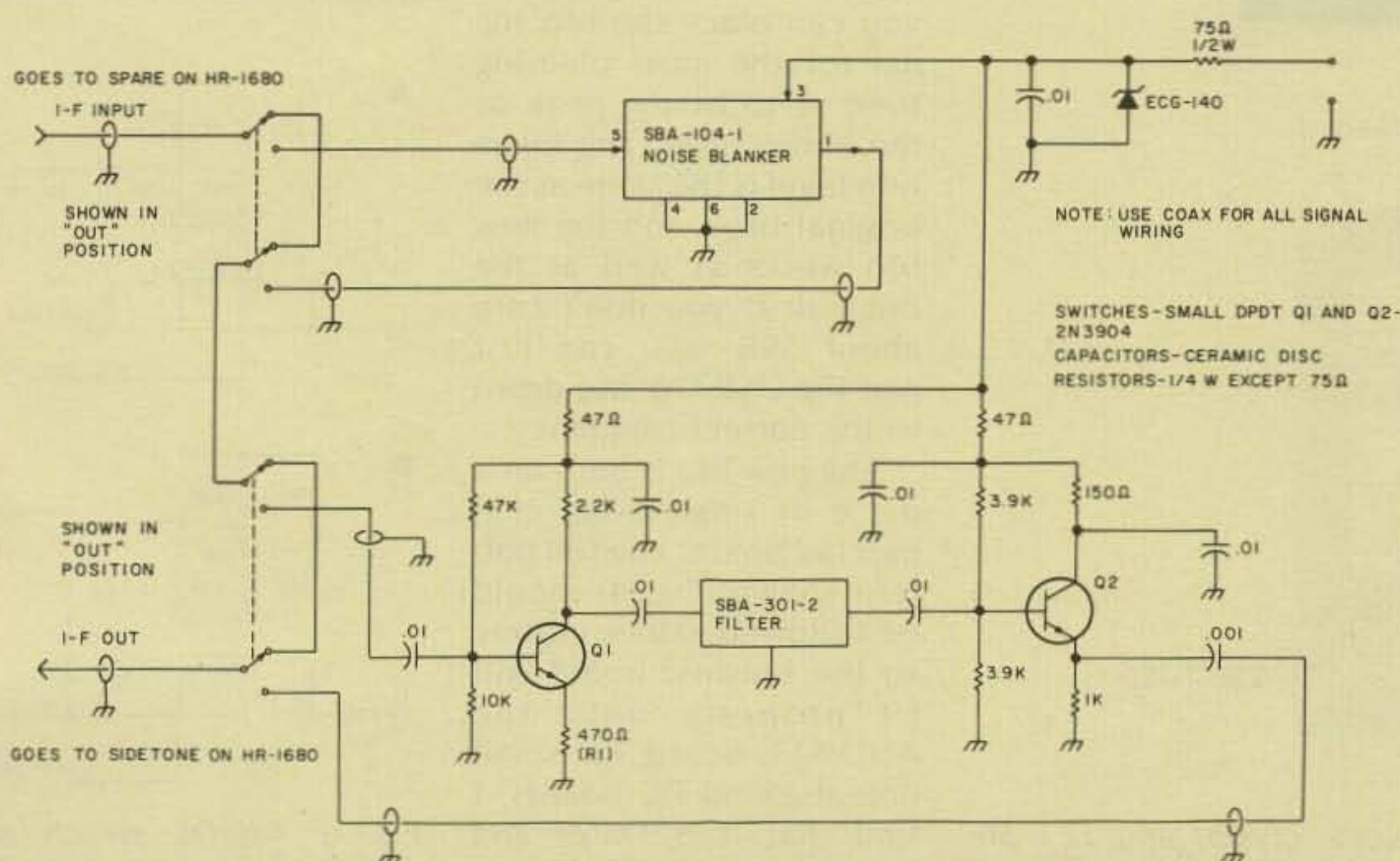

Fig. 1. Filter-blanker interface schematic diagram.

the same, and the different part numbers reflect the additional coils, diodes, etc., included in the SBA-401-1 for use in the SBA-104A transceiver. I am sure that either one would work. Buy the cheaper SBA-301-2.

The crystal filter has some insertion loss which must be made up, and it must be presented with the correct (2k Ohms) input and output impedance in

order to perform correctly. I used a circuit that I found in *Amateur Radio Techniques* by the RSCGB for the filter amplifier. The amplifier has a gain stage for input to the filter and an emitter-follower output (see Fig. 1). It does not use any inductive components, but it allows for a proper match into and out of the filter. The gain of the input stage is set by selecting the value of emitter resistor

R1. Details on gain calculation are shown in Fig. 2. With the values indicated, the first stage gain is approximately 13.4 dB (voltage) and this results in unity gain through the filter-amplifier combination. The nice thing about this circuit is that there is nothing to tune. The filter and its amplifier are mounted on a piece of copperclad board using the board fabrication method outlined in the bfo section.

Bfo

To obtain maximum benefit from the crystal filter, the bfo needs to provide a beat note of about 750 Hz to be within the bandpass of the HR-1680's audio filter. The frequency of the bfo should be 3395.4 kHz (filter center frequency), plus or minus 750 Hz. Several solutions suggested themselves, but I wanted to retain full SSB capabilities; so, fooling with one of the existing bfos was out. I built a new bfo using a 3395.7-kHz crystal (Heath part number 404-549, about \$5.70) in a slightly modified copy of the HR-1680 bfo circuit (See Fig. 3). The trimmer (C2) allows the crystal to be pulled upwards in frequency by as much as 700 Hz, so you can place the bfo signal for the most pleasing tone or to fit the peak of the audio filter. The injection level is the same as the original bfo's and the new bfo works as well as the original. If you don't care about SSB, you can just pad the USB-CW bfo down to the correct frequency.

The new bfo is built on a piece of single-sided copperclad board. The foil pattern shown (Fig. 4) should be followed rather closely so the finished board will fit properly onto the AUD/REG board. For small one-of-a-kind PC boards, I find that it is faster and easier to grind off the unwanted foil with a Dremel

Moto-Tool® or to score the foil with an X-acto® knife and peel off the unwanted foil, rather than to do all the things involved with etching. I used a Moto-Tool on the board that I built and it took less than an hour to produce a completed bfo.

The crystal and the FET are on the component side of the board (Fig. 5) and holes are drilled for their leads. All other components are on the foil side and no holes are required. Use a leftover PCB pin (Heath part 432-121) for the 13.8-volt connection.

The completed bfo board is mounted to the AUD/REG board using 4-40 hardware and one ¼-inch standoff. A small clearance hole must be drilled in the AUD/REG board just to the right of the connector sockets (viewing component side) that are below the existing bfo crystals (see Photo C). The exact location of the hole depends on your board, but the main idea is to have the new crystal snug against Y205 (and upside down) so as to create a compact piggyback fit.

Solder a small piece of bare wire from the new crystal to Y205 in the same fashion as was done for

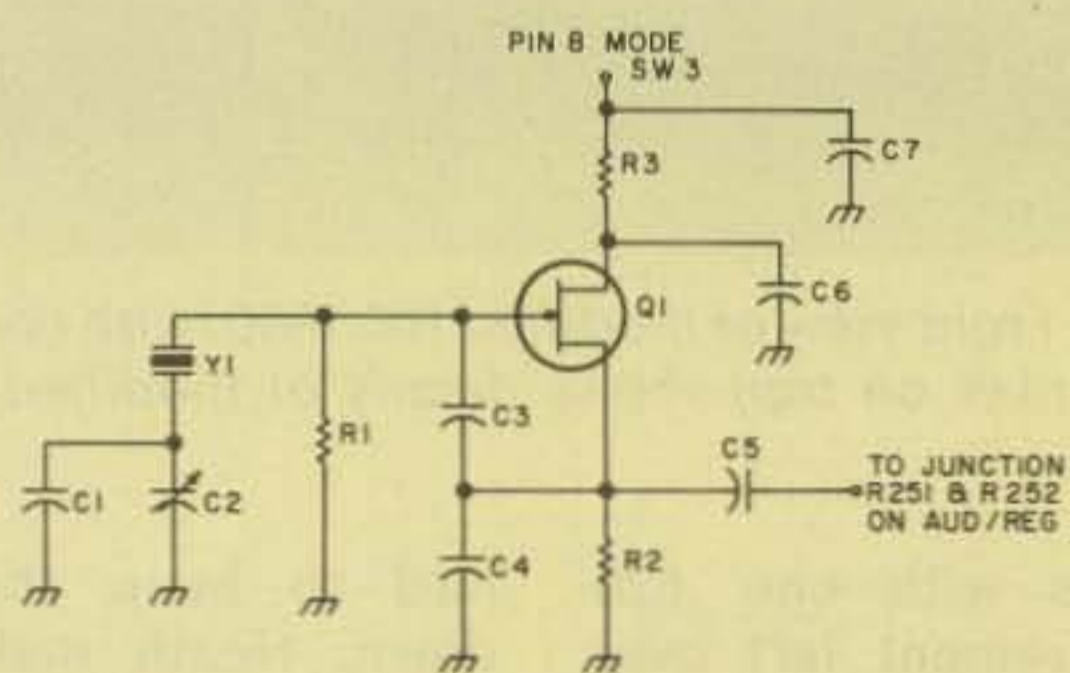

Fig. 3. Bfo schematic diagram.

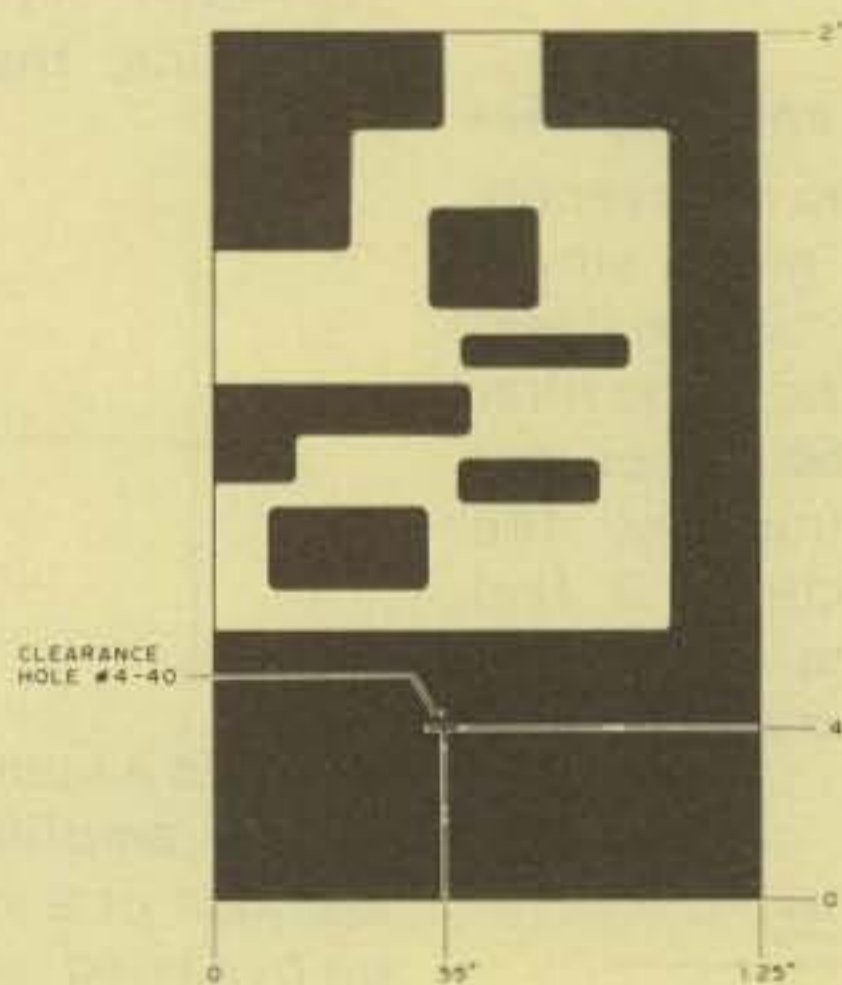

Fig. 4. PCB layout.

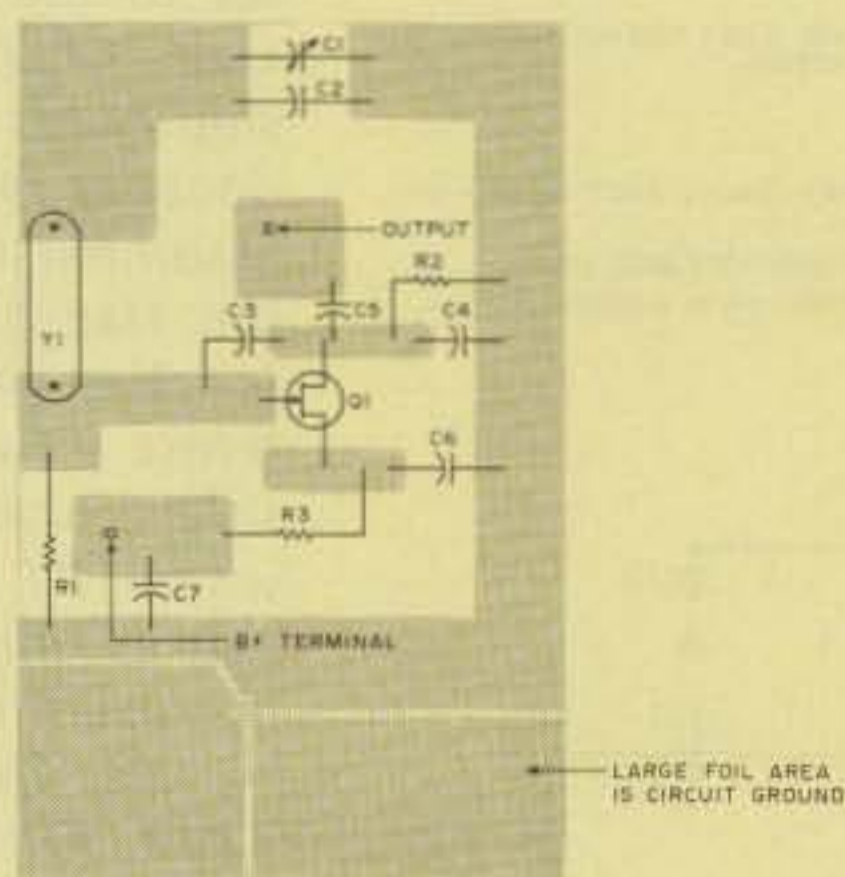

Fig. 5. Component location. Note: crystal and FET are mounted on the component side. All remaining components are mounted on the foil side.

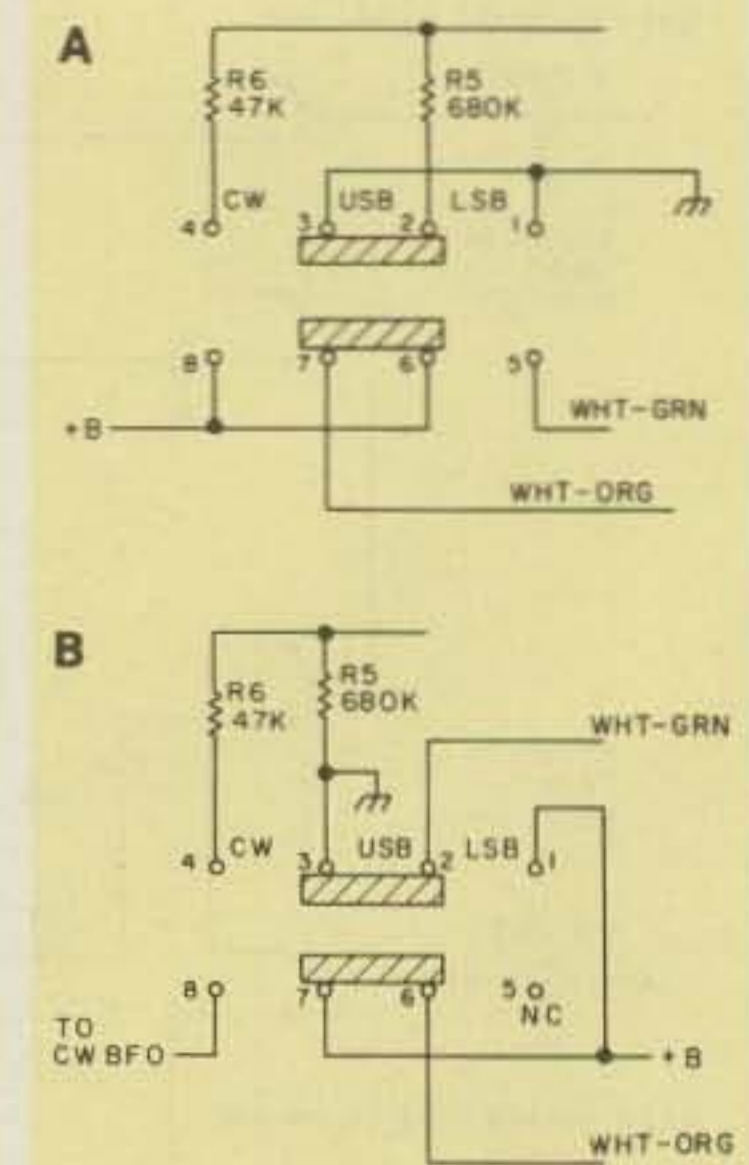

Fig. 6. MODE switch arrangement. (a) Original wiring. (b) After modifications.

Y203 and Y204 during the original assembly of the HR-1680. Connect an insulated wire between the ground foil on the new board to connector socket pin 13 of the AUD/REG board. Make sure that you do not get solder in the spring clips. Solder an insulated wire to the junction of R251 and R252 and solder the other end to the output land of C5 of the bfo board.

Mode Switch Wiring Changes

The MODE switch must be rewired so that the new bfo will be energized when the switch is placed into the CW position. Fig. 6 shows the original and modified connections.

Remove all connections to the MODE switch except for R6 (pin 4). Solder the end of R5 which was connected to pin 2 to the adjacent ground lug. Solder the red wire (originally connected to pins 6 and 8) to pin 7 and connect a short insulated jumper from pin 7 to pin 1. Solder the white-orange wire to pin 6. Solder the white-green wire to pin 2.

Secure a piece of #20 or #22 stranded insulated wire about two feet long. Solder one end of the wire to pin 8 of the MODE switch and dress the wire along the harness branch which contains the white-orange and the white-green wires to the AUD/REG board. Pull the free end of the wire through the ventilation hole which is almost directly under Q201. This wire is the 13.8-volt source for the CW bfo. Cut the free end to leave about three inches above the chassis, and install a leftover PCB connector (Heath part 432-120) or a pin removed from an old miniature tube socket at the free end of the wire.

Breaking the I-f Signal Path

The normal i-f signal

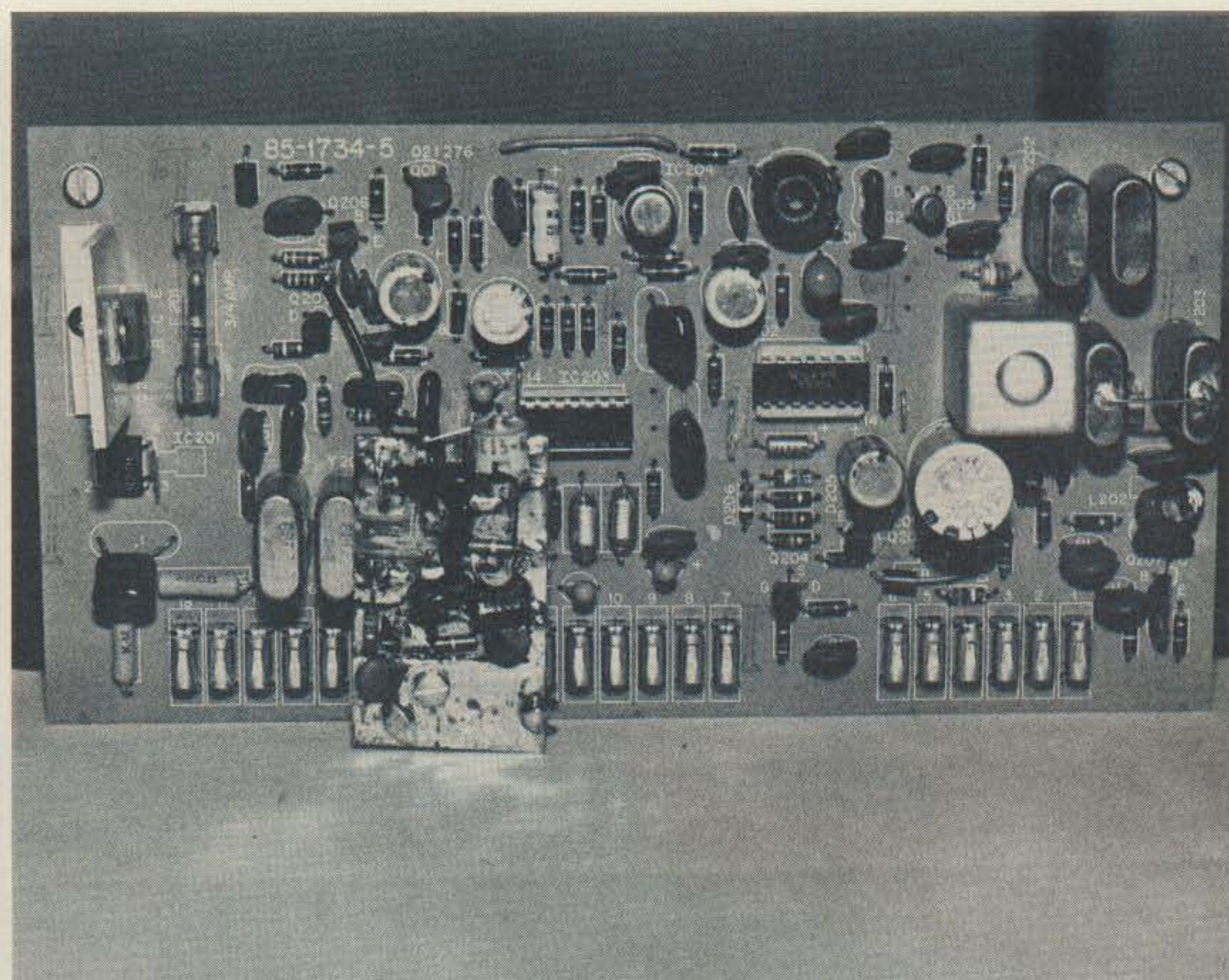

Photo C. Component-side view of AUD/REG board with new CW bfo board attached.

path in the receiver must be broken in order to insert the crystal filter and the noise blanker. The best and most convenient place to break the path is between the output of the FRONT END board and the AUD/REG board's input.

Disconnect the shielded cable with violet color coding from pins D1 and D2 of the AUD/REG board chassis socket. Dress the cable to the SPARE phono-type connector at the rear of the receiver. Solder the inner conductor to the inside terminal of the phono connector and the shield to the ground terminal.

Disconnect the 10k resistor from the SIDETONE phono connector and either remove it altogether or secure it so that it does not short to anything. Cut a piece of the shielded cable supplied with the blanker kit (or RG-174/U) long enough to reach from D1 and D2 of the AUD/REG board to the

SIDETONE jack. Solder the inner conductor to the inside terminal and the shield to the ground terminal of the SIDETONE jack.

The SPARE jack is now i-f out and the SIDETONE jack is i-f input. This change disables the sidetone feature of the receiver. If you want to retain the sidetone capability, you will have to install another connector somewhere. My sidetone comes from my keyer and the loss did not bother me. I assure you that the filter is worth a little trouble.

Noise Blanker

The SBA-104-1 noise blanker is very effective for some types of noise, notably automotive ignition noise and other types of short duration impulse noise. It does not do much good with long-term "grinding" noise like summer static and some types of power line noise. Since the HR-1680 does not have any noise limiter at all, the SBA-104-1 is a worthwhile improvement.

Build the noise blanker according to Heath's instructions, except change the value of R3 from 33

Parts List

- C1 - 47-pF silver mica
- C2 - 15 - 60-pF ceramic trimmer (Erie 528 type)
- C3 - 33-pF silver mica
- C4 - 330-pF silver mica
- C5 - 10-pF silver mica or ceramic
- C6,7 - .01 ceramic disc, 100 volts
- R1 - 47k, 1/4 Watt
- R2 - 330 Ohms, 1/4 Watt
- R3 - 1.5k, 1/4 Watt
- Q1 - 2N3819 or similar junction FET
- Y1 - 3395.7-kHz Heath part 404-549

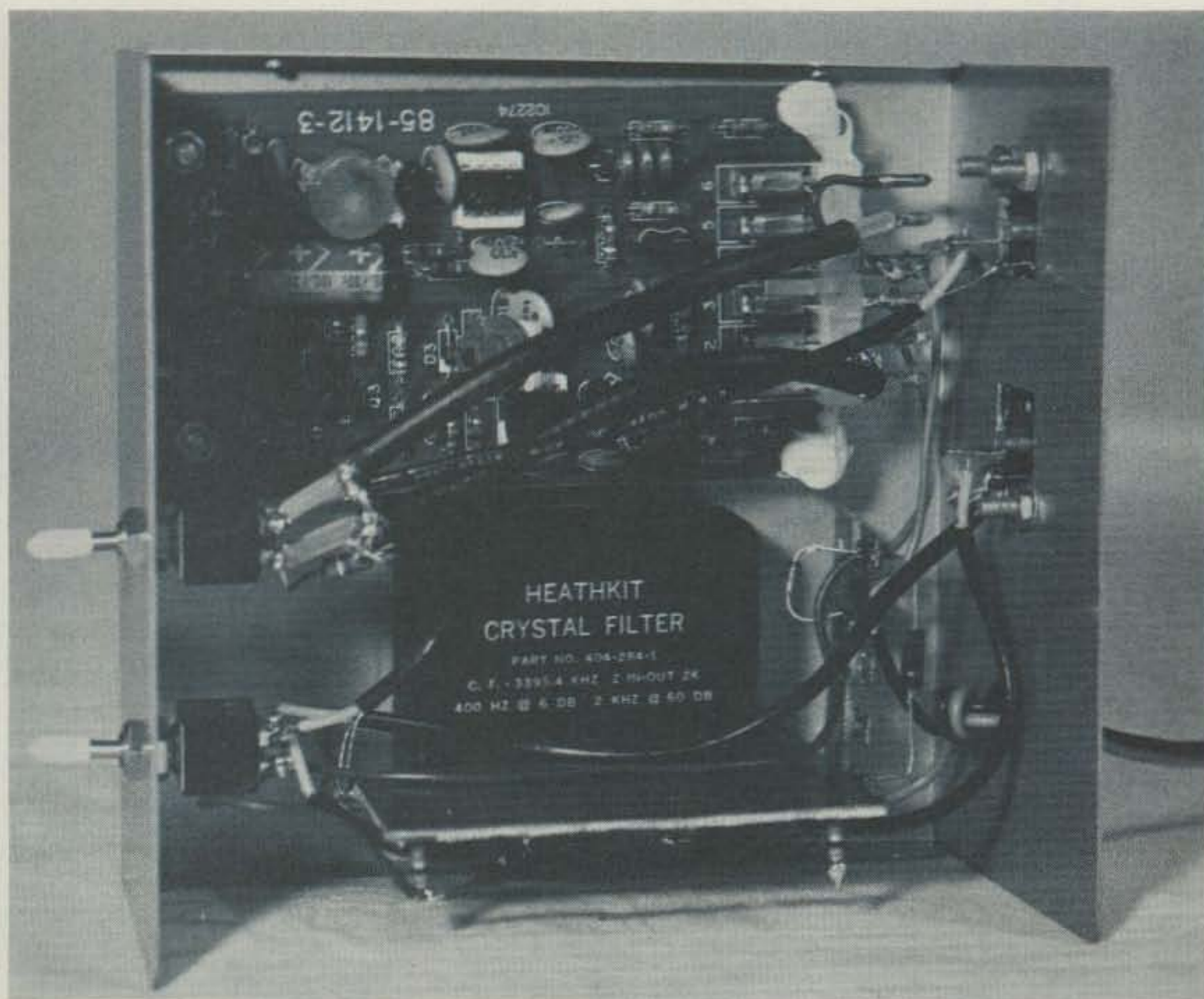

Photo D. Interior view of filter-blanker cabinet. Note globs of silastic rubber used to secure connector to PCB.

Ohms to 390 Ohms. The 390-Ohm resistor is included in the kit for use in the SB-104A and is not needed in the HR-1680. I could not see that the 560-Ohm resistor and the 2.2-uH coil were needed in the HR-1680, so I left them out.

The Heath manual discusses the increase in the IMD (intermodulation distortion) when the blanker is installed, and I noticed that a whole flock of "birdies" fly across the dial when the blanker is in the signal path. When you really need the blanker, all this does not matter, but it is not to be lived with when there is no noise. The best solution is to switch the blanker completely out of the circuit when it is not being used. The circuit diagram reflects this switching.

Filter-Blanker Power

13.8 volts is available at the external power connec-

tor at the rear of the set. This connector goes directly to series pass transistor Q201, and care should be exercised when using it because the fuse is ahead of the regulator. The blanker is normally connected to 11 volts, so I used one of several ECG-140s (10-volt) zeners that I had as a simple shunt regulator. The blanker and crystal filter work well with a 10-volt supply.

Checkout

Connect the filter-blanker combination to the HR-1680 using RG-58 coax with phono-type connectors at each end. The length of the cables is not critical, but they should not be too long. My cables are about 20 inches each and I could not measure any loss through the cables and switching arrangement.

Use Heath's instructions for checking and adjusting the blanker, except just

switch the blanker out for "initial" readings.

To check out the crystal filter, switch out the blanker, switch the MODE switch to USB, and switch the FUNCTION switch to CAL. Find one of the 100-kHz calibration signals (any band) and switch to CW to see if the new bfo is operating. The beat note will change pitch when the new bfo is switched in. Switch in the crystal filter and verify that it is working. Switch to WIDE and USB and find a strong CW signal or use the spot function on your transmitter. Switch to NAR and peak the signal on the audio filter of the HR-1680. Switch in the crystal filter and switch to CW and adjust the bfo trimmer for a beat note which is peaked at the audio filter center frequency. You should now be able to switch the filter and blanker in and out without changing the S-meter reading.

With the crystal filter switched out and the receiver in the WIDE position, an S-9 signal can be heard over three or four kHz. With the crystal filter switched in, the same signal can be heard over less than one kHz and the signal falls off sharply outside the passband of the filter. The audio filter is helpful in eliminating some of the higher frequency noise that the crystal filter passes.

The normal SSB filter is always in the signal path and this helps improve the overall shape of the passband of the receiver. With the circuit shown, the crystal filter is properly terminated and does not have the "ringing" often associated with sharp filters. In fact, at first I did not think that it was working correctly because the audio was so natural sounding. I purposely mismatched the filter and the typical "ringing" was there. With the new bfo and using only the wider SSB filter, you can now actually zero-beat a signal. This is extremely handy at times.

Conclusion

With the modifications that I have outlined, the HR-1680 becomes a superb CW receiver which out-classes almost every secondhand set and is equal to many new and much more expensive sets. ■

Bibliography

- Hawker, Pat, *Amateur Radio Techniques*, Radio Society of Great Britain, Letchworth, Hertfordshire, G.B., page 63, 1978.
- Waters, Mort W2NZ, "Improving CW Reception on the SB-303," *QST*, July, 1972.
- Frankel, S. Henry WB2DQP, "A New-Look Noise Blanker That Works," *QST*, January, 1977.
- Davis, Al WA2KOC, "Still More on the SBA-104-1 Noise Blanker," *QST*, August, 1977.
- Clarke, C.P. EI3CP, "Variable-Bandwidth Filters—Irish Style," *Technical Correspondence, QST*, March, 1978.