

# TOSHIBA

11 BAND RECEIVER

## RP-F11/F11L

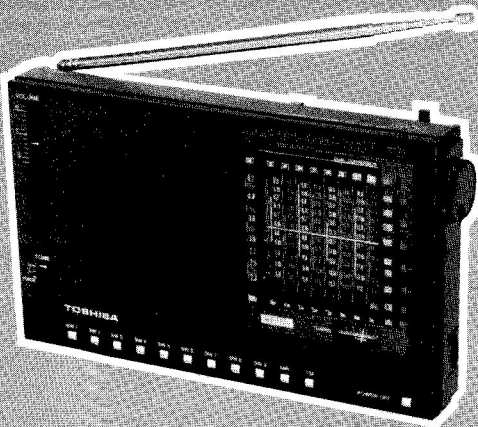

### SPECIFICATIONS

<b>Frequency Range:</b> (TE, YY)	FM	88-108 MHz	SW5	13.5-14.0 MHz (22mb)
	MW	525-1605 kHz	SW6	15.1-15.6 MHz (19mb)
	SW1	2.3-5.1 MHz (120, 90, 75.60mb)	SW7	17.5-18.0 MHz (16mb)
	SW2	5.8-6.3 MHz (49mb)	SW8	21.4-21.9 MHz (13mb)
	SW3	7.0-7.5 MHz (41mb)	<b>Power Requirement:</b> DC 6V Batteries: IEC R6 ("AA" cell) x 4 AC adaptor: DC 6V output of positive centre pin	
	SW4	9.4-9.9 MHz (31mb)		
	SW5	11.6-12.1 MHz (25mb)		
	SW6	13.5-14.0 MHz (22mb)		
	SW7	15.1-15.6 MHz (19mb)		
<b>Frequency Range:</b> (L-TE)	SW8	17.5-18.0 MHz (16mb)	<b>Speaker:</b> Approx 77mm dia. <b>Power Output:</b> 700 mW (max.) <b>Jacks:</b> Recording jack Earphone jack External power jack; DC 6V positive centre pin	
	SW9	21.4-21.9 MHz (13mb)		
	FM	88-108 MHz		
	LW	155-263 kHz		
	MW	525-1605 kHz		
<b>Dimensions:</b> 198(W) x 116(H) x 34(D) mm <b>Weight:</b> 630 g (including batteries)	SW1	5.8-6.3 MHz (49mb)		
	SW2	7.0-7.5 MHz (41mb)		
	SW3	9.4-9.9 MHz (31mb)		
	SW4	11.6-12.1 MHz (25mb)		

Specifications are subject to change without notice.



# 1. OPERATING CONTROLS

Follow the numerical sequence

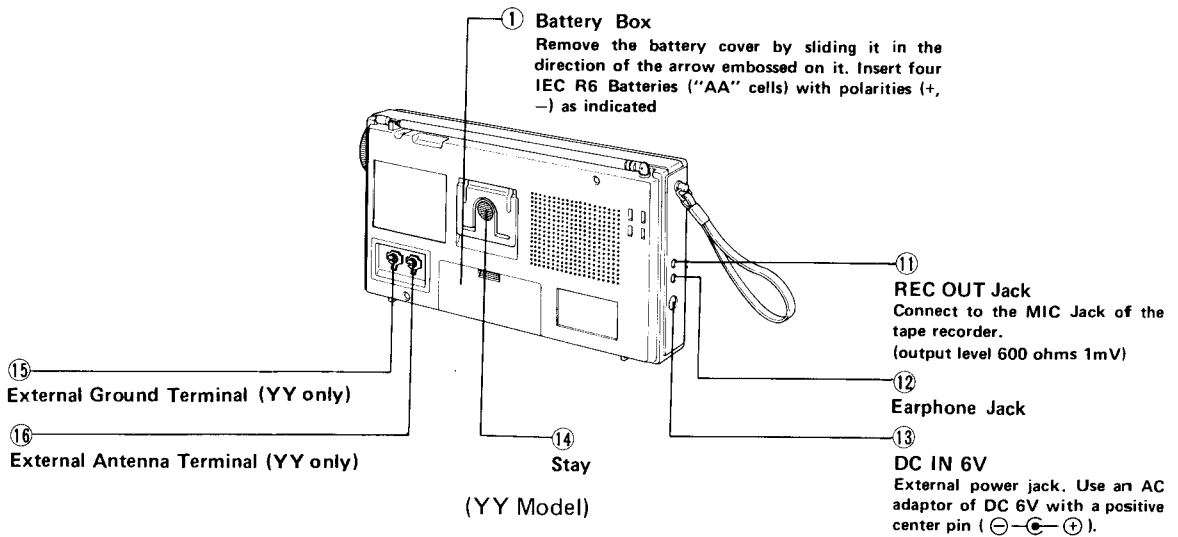
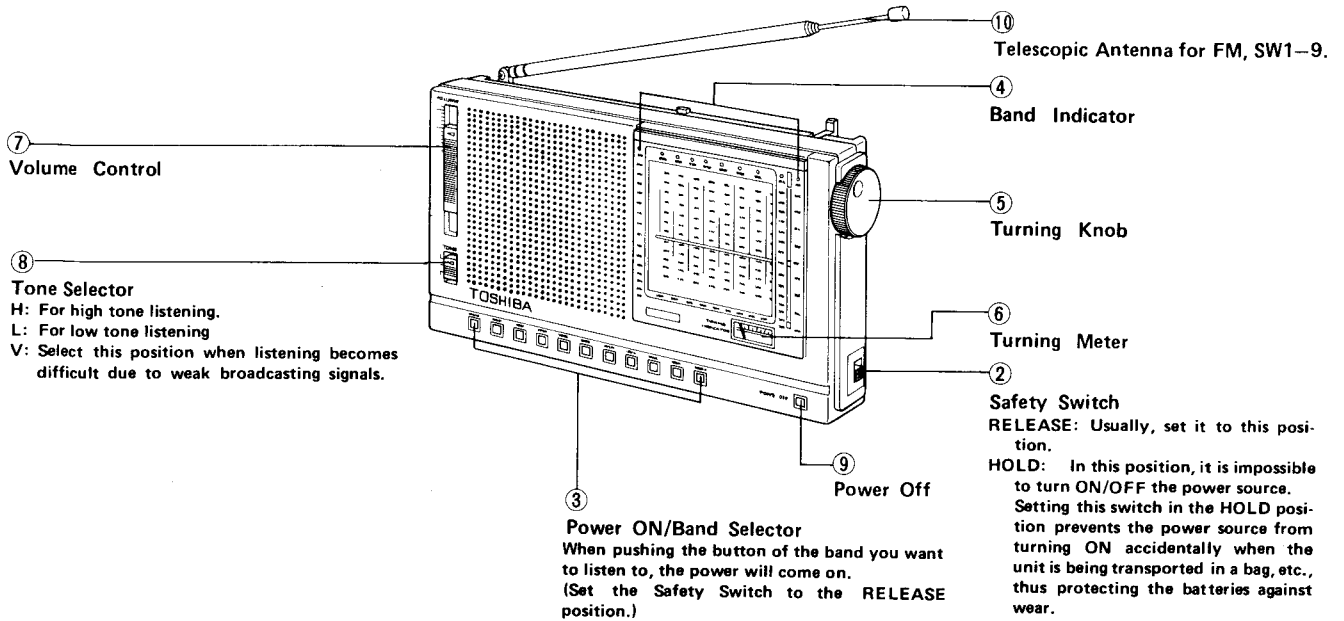

## HOW TO USE THE ROD ANTENNA

This antenna is effective for use in FM, SW1 to SW9 bands, but has no effect on MW broadcasts.

Pull out the rod antenna in the direction shown by the arrow.

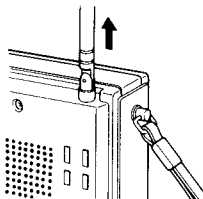

Pull out the rod antenna to its full extension and adjust its angle to get the optimum reception.  
 When listening to FM broadcasts

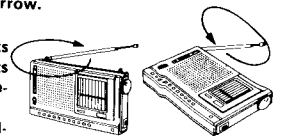

Pull out the rod antenna to its full extension and leave it in vertical position.  
 When listening to SW1-SW9 broadcasts.

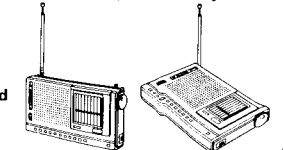

Figure 1

**CAUTION:** Before returning the unit to the customer, check that the resistance between both blades of AC plug and any accessible metal parts is more than 3 MΩ after completion of servicing, using the circuit tester. (TA Model only)

## 2. DISASSEMBLY INSTRUCTIONS

### BACK CABINE REMOVAL

1. Remove three screws (A) and one screw (B), then press the hooked part (C) so the back cabinet can be removed.

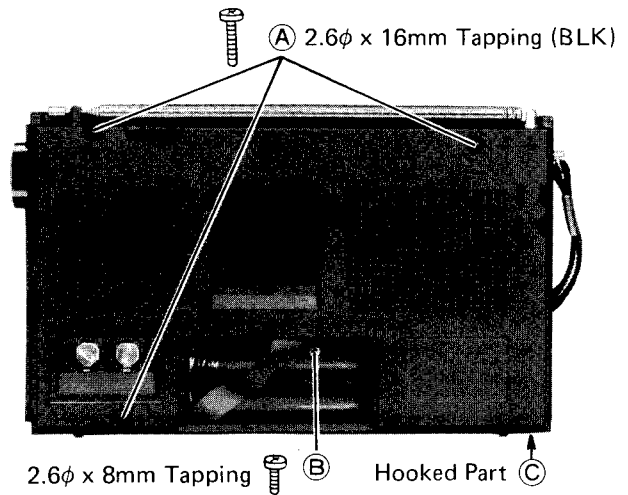

Figure 2

### P.C. BOARD AND FRAME REMOVAL

1. Pull to remove the tuning knob.
2. Remove one screw (D) and unsolder (E) and (F), then open the Jack plate side of the Front cabinet (G) a little, and lift the P.C.Board and the Frame so they can be removed.

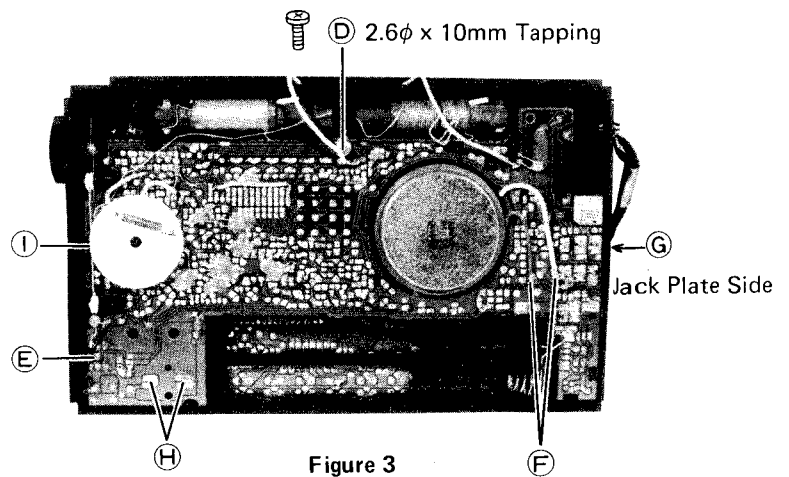

Figure 3

### REMOVAL OF THE FRAME FROM THE P.C.BOARD

1. Unsolder the meter terminals (H) and remove the meter.
2. Remove the Dial Cord (I), and the LED P.C.Board and the Switch P.C.Board so the Frame can be removed from the P.C.Board.

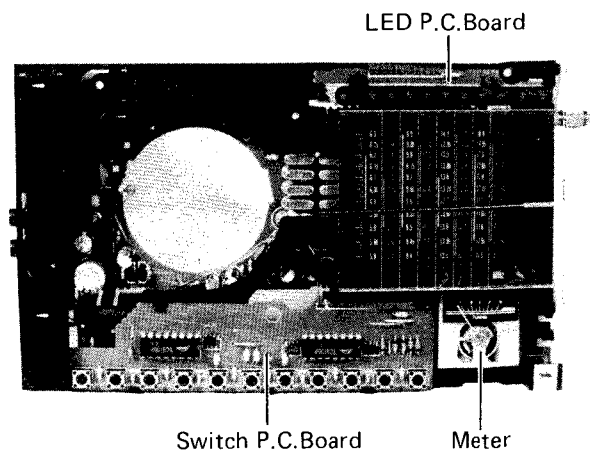

Figure 4

### 3. DIAL CORD RESTRINGING

1. Tie the Dial Cord to the spring.
2. Turn the drum on the variable capacitor full counterclockwise, and hook it to the spring, then restring in the numerical order.
3. After restringing the Dial Cord , turn the drum full counterclockwise, then set the pointer to "0" point on the scale.

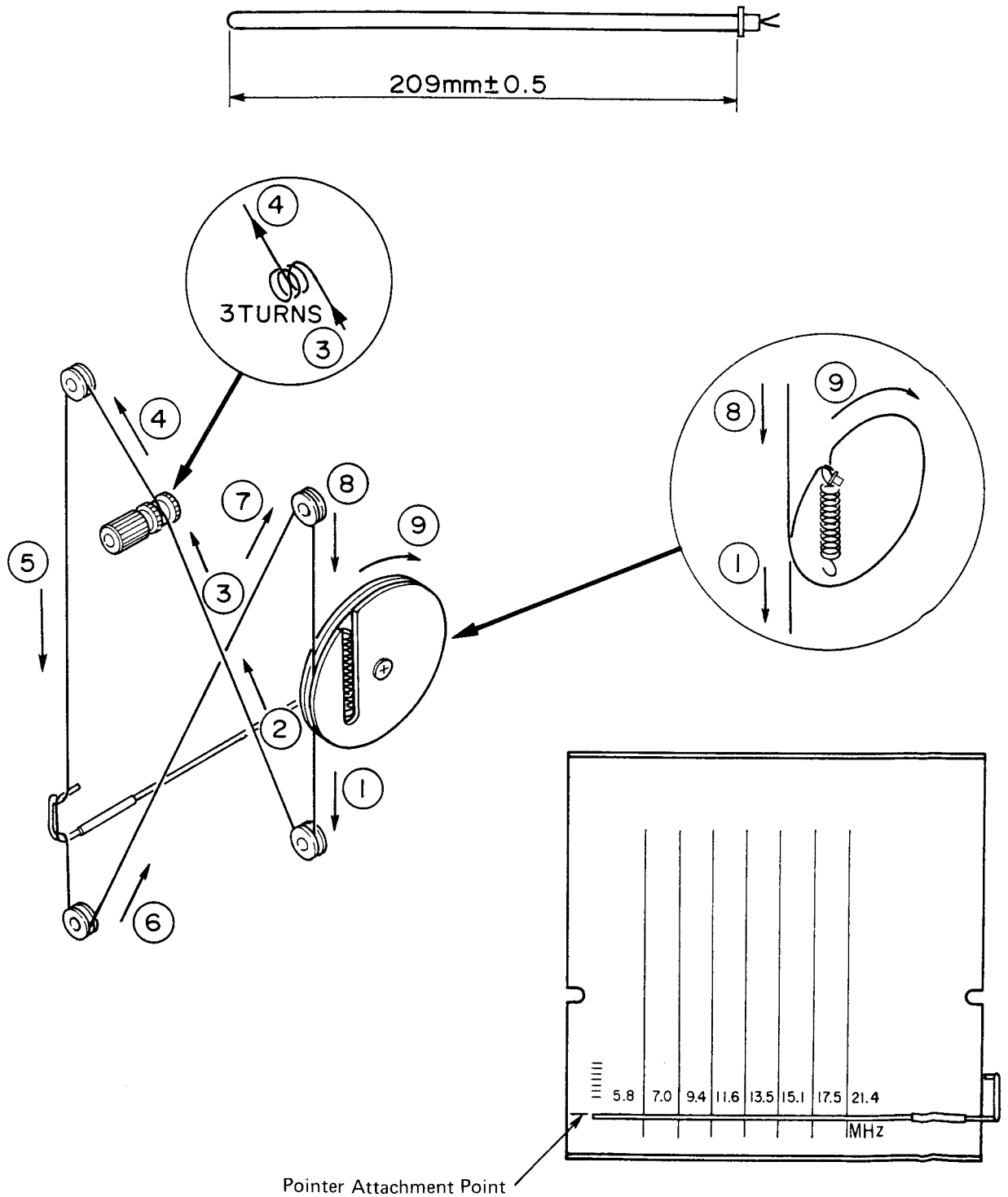

Figure 5

## 4. ADJUSTMENTS

### AM ALIGNMENT

1. Turn on the AM signal generator and the VTVM allowing a fifteen-minute warm-up period.
2. Using the test loop across the output of the signal generator, inductively connect the signal generator to the radio.
3. Connect the VTVM across the voice coil or Ear Phone Jack.
4. Set signal generator frequency as listed in ALIGNMENT CHART and maintain a sufficient output level to provide an indication on VTVM.
5. Set volume control at mid-position.
6. Proceed as outlined in the IF, MW and LW/SW ALIGNMENT CHARTS.
7. Adjust in the sequence shown by step numbers.

#### 1. MW ALIGNMENT CHART (Fig. 6)

Band	Step	Signal Generator Frequency	Radio Dial Setting	Adjustment	Remarks
IF	1	460 kHz	Tuning Gang Fully Counter-clockwise (Lowest Frequency)	T103, T104	Adjust for maximum indication.
MW	2	515 kHz 510 kHz (L-TE)	Tuning Gang Fully Counter-clockwise (Lowest Frequency)	OSC. Coil L020 (MW)	Adjust for maximum indication.
	3	1650 kHz	Tuning Gang Fully clockwise (Highest Frequency)	OSC. Trim C006-C	Adjust for maximum indication.
	4	Repeat steps 2 and 3 as required.			
	5	600 kHz	Tune to Signal.	Ant. Coil L006 (MW)	Adjust for maximum indication.
	6	1400 kHz	Tune to Signal.	Ant. Trim. C006-D	Adjust for maximum indication.
	7	Repeat steps 5 and 6 as required.			

#### 2. SW1 (120 ~ 60mb)/LW ALIGNMENT (Fig. 6)

Band	Step	Signal Generator Frequency	Radio Dial Setting	Adjustment	Remarks
SW1	1	5200 kHz	Tuning Gang Fully Clockwise (Highest Frequency)	OSC. Coil L022	Adjust for maximum indication.
	2	4500 kHz	Tune to Signal.	Ant. Coil L006-SW	Adjust for maximum indication.
LW	1	270 kHz	Tuning Gang Fully Clockwise (Highest Frequency)	OSC. Trim C047	Adjust for maximum indication.
	2	270 kHz	Tuning Gang Fully Clockwise (Highest Frequency)	Ant. Coil L006-LW	Adjust for maximum indication.

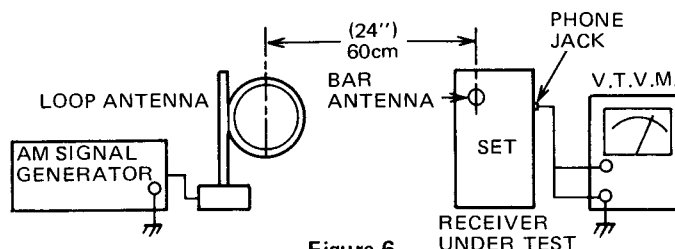

Figure 6

3. 2nd OSC. ALIGNMENT (Fig. 7)

Band	Step	Signal Generator Frequency	Radio Dial Setting	Adjustment	Remarks
SW 41mb	1	6.95 MHz	Tuning Gang Pulley Counter-clockwise (Lowest Frequency)	OSC. Trim C041	Adjust for maximum indication.
	2	7.55 MHz	Tuning Gang Fully Clockwise (Highest Frequency)	OSC. Coil L021	Adjust for maximum indication.
	3	Repeat steps 1 and 2 as required.			

4. 1st IF ALIGNMENT (Fig. 7)

Band	Signal Generator Frequency	Radio Dial Setting	Adjustment	Remarks
SW 31mB	10.7 MHz	Tune to Signal.	T102	Adjust for maximum indication

5. SW. Ant Coil ALIGNMENT (Fig. 7)

Band SW	Step	Signal Generator Frequency	Radio Dial Setting	Adjustment	Remarks
13mb	1	21.65 MHz	Tune to Signal.	L010	Adjust for maximum indication.
16mb	2	17.925 MHz	Tune to Signal.	L011	Adjust for maximum indication.
19mb	3	15.35 MHz	Tune to Signal.	L012	Adjust for maximum indication.
22mb	4	13.7 MHz	Tune to Signal.	L013	Adjust for maximum indication.
25mb	5	11.85 MHz	Tune to Signal.	L014	Adjust for maximum indication.
31mb	6	9.7 MHz	Tune to Signal.	L015	Adjust for maximum indication.
41mb	7	7.2 MHz	Tune to Signal.	L016	Adjust for maximum indication.
49mb	8	6.075 MHz	Tune to Signal.	L017	Adjust for maximum indication.

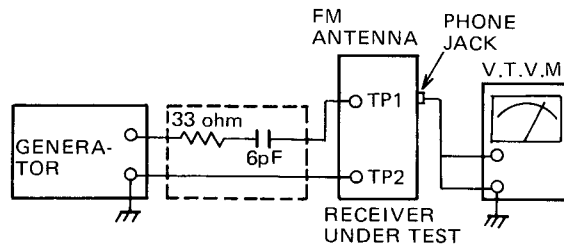

Figure 7

**FM-IF ALIGNMENT (Fig. 8)**

1. Set the select switch to FM position.
2. Turn on both sweep generator and oscilloscope, and allow a fifteen-minute warm-up period.
3. Connect the RF SWEEP SIGNAL OUTPUT from the signal generator through the loop antenna to the receiver.
4. Connect the oscilloscope vertical input through the capacitor (3.3/50) to the test point 3 (DET OUT) and connect the shielded lead to the chassis ground.
5. Connect the SWEEP VOLTAGE OUTPUT of the sweep generator to the oscilloscope.
6. Proceed as outlined in the FM-IF ALIGNMENT CHART.

**FM-IF ALIGNMENT CHART**

Step	Signal coupling	Equip.	Tuning	Connection	Adjust. point	Pattern
1	Connect sweep generator output to a three-turn loop antenna of 10 cm diameter.	Sweep generator of 10.7 MHz center freq. with 10.7 MHz meter.	Tuning Knob fully counterclockwise (Lowest Frequency)	Set scope for connecting output signal from TP-3 to vertical axis of scope "V" and sweep generator output to horizontal axis "H".	T101 T105 T106	Turn the coil L106 fully counterclockwise to obtain a single peak. Fig. 9 Adjust coil T101 and T105 in order until the best single peak is obtained. Finally turn the coil T106 to obtain S curve. Fig. 10

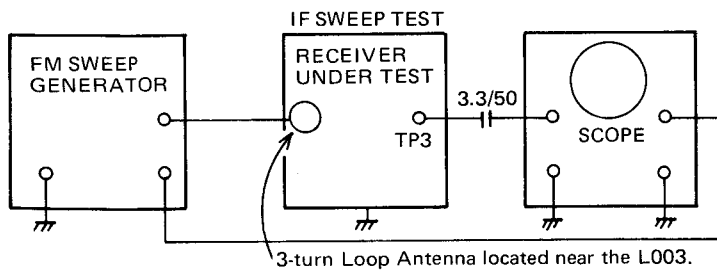

Figure 8

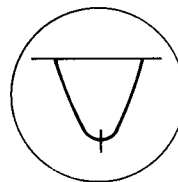

Figure 9

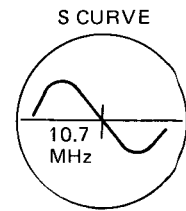

Figure 10

**FM-RF ALIGNMENT (Fig. 11)**

1. Turn on the signal generator and the VTVM, and allow a fifteen-minute warm-up period.
2. Connect the signal generator output through a 75 ohm dummy antenna across FM ANT.
3. Connect the VTVM across the voice coil or Ear Phone Jack.
4. Set the volume control to mid-position.
5. Adjust the signal generator frequency as indicated in FM-RM ALIGNMENT CHART, and maintain a sufficient signal output level to provide a measurable indication.
6. Proceed as outlined in the FM-RF ALIGNMENT CHART.

**FM-RF ALIGNMENT CHART**

Step	Signal Generator	Radio Dial Setting	Adjustment	Remarks
1	87.5 MHz	Tuning Knob fully Counterclockwise (Lowest Frequency)	OSC. Coil L004	Adjust for maximum output indication.
2	108.0 MHz	Tuning Knob fully Clockwise (Highest Frequency)	OSC. Trim C006-A	Adjust for maximum output indication.
3	Repeat steps 1 and 2 as required.			
4	90 MHz	Tune to signal.	Ant. Coil L003	Adjust for maximum output indication.
5	106 MHz		Ant. Trim. C006-B	
6	Repeat steps 4 and 5 as required.			

**CAUTION:**

When realigning the FM Receiving Frequency, the highest end of the frequency range should not be more than 108 MHz and the lowest end of the frequency range should not be less than 87.5 MHz, in order to comply with FTZ regulations in West Germany.

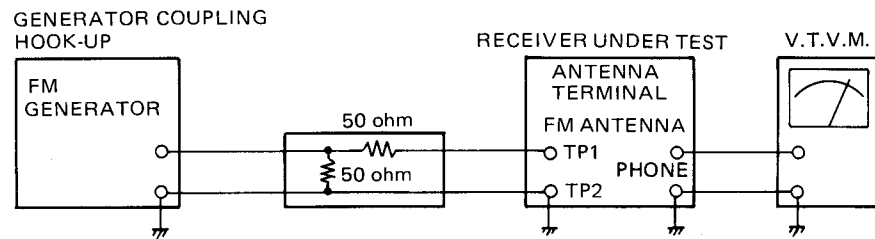

Figure 11



# 5. VOLTAGE CHART

## Q001

1	FM 0.9V, MW 0.1V SW1~SW5 0.1V, SW6~SW9 0.2V
2	FM 1.6V, MW 0.8V SW1~SW5 0.8V, SW6~SW9 0.9V
3	FM 5.0V, MW 0.9V SW1~SW5 0.9V, SW6~SW9 1.1V
4	FM 1.5V, MW 0.7V SW1~SW9 0.8V
5	OV
6	FM 5.0V, MW 0.9V SW1~SW5 0.9V, SW6~SW9 1.1V
7	FM 4.3V, MW 0.5V SW1~SW5 0.5V, SW6~SW9 0.4V
8	FM 5.0V, MW 0.9V SW1~SW5 0.9V, SW6~SW9 1.1V
9	FM 5.0V, MW 0.9V SW1~SW5 0.9V, SW6~SW9 1.1V

## Q002

E	FM 0V, MW 4.2V SW1 4.1V, SW2~SW9 0.4V
C	FM 0.02V, MW 4.9V SW1 4.8V, SW2~SW9 1.1V
B	FM 0.1V, MW 4.9V SW1 4.8V, SW2~SW9 1.1V

## Q003

D	FM 0V, MW 4.2V SW1 4.1V, SW2~SW9 0.4V
G	OV
S	FM 0V, MW 0.3V SW1~SW9 0.3V

## Q004

E	FM-MW 0V, SW1 0V, SW2~5 4.2V SW6 4.0V, SW7~SW9 4.1V
C	FM-MW 0V, SW1 0V, SW2~5 4.9V SW6 4.7V, SW7~SW9 4.9V
B	FM-MW 0V, SW1 0V, SW2~5 5.0V SW6 4.8V, SW7~SW9 4.9V

## Q005

D	FM-MW 0V, SW1 0V, SW2~5 4.2V SW6 4.0V, SW7~SW9 4.1V
G	OV
S	OV

## Q006

D	FM-MW 0V, SW1 0V, SW2~5 4.9V SW6 4.8V, SW7~SW9 4.9V
G	OV
S	FM-MW 0V, SW1 0V SW2~5 0.7V, SW6~SW9 0.6V

## Q007

E	FM 0.5V, MW 5.3V SW1 5.3V, SW2~SW9 5.0V
C	FM 0V, MW 5.3V SW1 5.3V, SW2~SW9 1.4V
B	FM 0.5V, MW 4.6V, SW1 4.6V SW2~5 0.5V, SW6 4.9V, SW7~9 5.0V

## Q008

E	FM 0.5V, MW 5.3V SW1 5.3V, SW2~SW9 5.0V
C	FM-MW 0V, SW1 0V SW2~SW4 5.0V, SW5~SW9 4.9V
B	FM 0V, MW 5.3V SW1 5.3V, SW2~SW9 4.3V

## Q009

D	FM 0.5V, MW 5.3V, SW1 5.3V SW2~5 5.0V, SW6 4.9V, SW7~9 5.0V
G	FM 0.02V, MW 5.3V, SW1 5.3V SW2~SW9 1.4V
S	FM 0.5V, MW 5.3V, SW1 5.3V SW2~5 5.0V, SW6 4.9V, SW7~9 5.0V

## Q010

D	FM 0.5V, MW 5.3V, SW1 5.3V SW2~5 5.0V, SW6 4.9V, SW7~9 5.0V
G	FM 0.5V, MW 0.8V, SW1 0.9V SW2~5 5.0V, SW6 4.9V, SW7~9 5.0V
S	FM 0.5V, MW 5.3V, SW1 5.3V SW2~5 5.0V, SW6 4.9V, SW7~9 5.0V

## Q011

E	OV
C	FM-MW 0V, SW1 0V SW2~5 3.6V, SW6 3.4V, SW7~9 3.5V
B	FM-MW 0V, SW1 0V SW2~9 0.7V

## Q012

D	FM-MW 0V, SW1 0V SW2~5 5.0V, SW6 4.9V, SW7~9 4.9V
G	FM-MW 0V, SW1 0V, SW2~4 0.6V SW5 0.8V, SW6 1.9V, SW7~9 0.9V
S	FM-MW 0V, SW1 0V SW2~5 1.0V, SW6 2.1V, SW7~9 1.1V

## Q013

E	OV
C	FM-MW 0V, SW1 0V SW2~5 1.0V, SW6 2.1V, SW7~9 1.1V
B	FM-MW 0V, SW1 0V SW2~SW9 0.6V

## Q101

E	OV
C	FM 2.7V, MW 0.8V SW1~SW9 0.8V
B	FM 0.7V, MW 0.6V SW1~SW9 0.6V

## Q102

1	FM 0.5V, MW 5.3V, SW1 5.3V SW2~5 5.0V, SW6 4.9V, SW7~9 5.0V
2	FM 0.7V, MW 0.4V SW1~SW5 0.4V, SW6~SW9 0.5V
3	OV
4	FM 3.3V, MW 0.4V SW1~SW5 0.5V, SW6~SW9 0.6V
5	FM 3.8V, MW 0.4V SW1~SW5 0.5V, SW6~SW9 0.6V
6	FM 4.9V, MW 0.9V SW1~SW5 0.9V, SW6~SW9 1.1V
7	FM 4.5V, MW 0.9V SW1~SW5 0.9V, SW6~SW9 1.1V
8	FM 3.8V, MW 0.4V SW1~SW5 0.5V, SW6~SW9 0.6V
9	OV
10	FM 0V, MW 0.74V SW1~SW9 0.74V
11	FM 0.5V, MW 5.3V, SW1 5.3V SW2~5 5.0V, SW6 4.9V, SW7~9 5.0V
12	FM 0.5V, MW 5.3V, SW1 5.3V SW2~5 5.0V, SW6 4.9V, SW7~9 5.0V
13	FM 0V, MW 0.6V SW1~SW9 0.6V
14	FM 0V, MW 0.7V SW1~SW9 0.7V
15	FM 0.5V, MW 5.3V, SW1 5.3V SW2~5 5.0V, SW6 4.9V, SW7~9 5.0V
16	FM 0V, MW 0.7V SW1~SW9 0.7V

## Q103

E	FM 0V, MW 0.5V SW1~SW9 0.5V
C	6.0V
B	FM 0.2V, MW 0.04V SW1~SW9 0V

## Q104

E	5.9V
C	FM 0.5V, MW 5.9V SW1~SW9 5.9V
B	FM 5.9V, MW 5.2V SW1~SW9 5.2V

## Q105

E	5.9V
C	FM 5.9V, MW 0.9V SW1~SW5 1.0V, SW6~SW9 1.2V
B	FM 5.2V, MW 5.4V SW1~SW9 5.3V

## Q401

E	OV
C	FM 0.1V, MW 5.4V SW1~SW9 5.3V
B	FM 0.7V, MW 0.5V SW1~SW9 0.5V

## Q402

1	OV
2	FM 5.7V, MW 0.1V SW1~SW9 5.7V
3	FM 5.7V, MW 5.7V SW1~SW8 5.7V, SW9 0.2V
4	FM 5.7V, MW 5.7V SW1~SW7 5.7V, SW8 0.2V, SW9 5.7V
5	FM 5.7V, MW 5.7V, SW1~SW6 5.7V SW7 0.2V, SW8~SW9 5.7V
6	FM 5.7V, MW 5.7V, SW1~SW5 5.7V SW6 0.2V, SW7~SW9 5.7V
7	FM 0V, MW 0.6V SW1~SW5 0V, SW6~SW9 0.6V
8	FM 6.0V, MW 6.0V SW1~SW9 6.0V
9	FM 0V, MW 0V SW1~SW5 0.6V, SW6~SW9 0V
10	FM 5.7V, MW 5.7V SW1~SW5 0.03V, SW6~SW9 5.7V
11	5.7V
12	5.7V
13	5.7V
14	5.7V
15	5.7V
16	6.0V

## Q403

E	OV
C	FM 5.7V, MW 0.1V SW1~SW5 5.7V, SW6~SW9 0.1V
B	FM 0V, MW 0.6V SW1~SW5 0V, SW6~SW9 0.6V

## Q404

E	OV
C	FM 5.7V, MW 5.7V SW1~SW5 0.03V, SW6~SW9 5.7V
B	FM-MW 0V SW1~SW5 0.6V, SW6~SW9 0V

## Q405

1	OV
2	FM 0V, MW 0V SW1~SW5 0.6V, SW6~SW9 0V
3	FM 5.7V, MW 5.7V, SW1~SW4 5.7V SW5 0.2V, SW6~SW9 5.7V
4	FM 5.7V, MW 5.7V, SW1~SW3 5.7V SW4 0.2V, SW5~SW9 5.7V
5	FM 5.7V, MW 5.7V, SW1~SW2 5.7V SW3 0.2V, SW4~SW9 5.7V
6	FM 5.7V, MW 5.7V, SW1 5.7V SW2 0.2V, SW3~SW9 5.7V
7	FM 4.2V, MW 5.4V, SW1 0.2V SW2~SW9 4.6V
8	6.0V
9	FM 0V, MW 6.0V SW1~SW5 0V, SW6~SW9 6.0V
10	5.7V
11	5.7V
12	5.7V
13	5.7V
14	5.7V
15	FM 5.7V, MW 0.1V SW1~SW5 5.7V, SW6~SW9 0.1V
16	6.0V

## Q406

1	2.9V
2	0V
3	3.0V
4	1.4V
5	0V
6	2.9V
7	5.9V
8	5.9V
9	3.0V

## Q407

E	OV
C	0.01V
B	0.7V

## Q408

E	0.7V
C	0.7V
B	0.01V

## Q409

E	6.0V
C	5.9V
B	5.3V

## DO01

A	FM 0.8V, MW 5.9V, SW1 1.5V SW2~SW9 1.6V
C	FM 0.1V, MW 5.4V SW1~SW9 5.3V

## DO02

A	FM 5.0V, MW 0.9V SW1~SW5 0.9V, SW6~SW9 1.1V
C	FM 4.8V, MW 0.7V SW1~SW5 0.7V, SW6~SW9 0.8V

## DO03

A	OV
C	OV

## DO04

A	FM 0.8V, MW 1.6V SW1 1.0V, SW2~SW9 1.6V
C	FM 4.2V, MW 5.4V SW1 0.2, SW2~SW9 4.5V

## DO05

A	FM 0.5V, MW 0.8V SW1 1.0V, SW2~SW9 5.0V
C	FM 4.2V, MW 5.4V SW1 0.2V, SW2~SW9 4.5V

## DO06

A	FM 0.6V, MW 5.5V, SW1 0.6V SW2 0.8V, SW3~SW9 0.9V
C	FM 5.7V, MW 5.7V SW1 5.7V, SW2 0.2V, SW3~SW9 5.7V

## DO07

A	FM 0.5V, MW 0.8V, SW 1.0V SW2~SW9 5.0V
C	FM 5.7V, MW 0.2V SW1~SW9 5.7V

## DO08

A	FM 0.8V, MW 5.9V SW1 1.5V, SW2~SW9 1.6V
C	FM 1.1V, MW 5.8V SW1 0.6V, SW2~SW9 0.9V

## DO09

A	FM 0.6V, MW 5.5V SW1 0.6V, SW2~SW9 0.9V
C	FM 5.7V, MW 5.7V SW1~SW8 5.7V, SW9 0.2V

## DO10

A	FM 0.6V, MW 5.5V SW1 0.6V, SW2~SW9 0.9V
C	FM-MW 5.7V, SW1~SW7 5.7V SW8 0.2V, SW9 5.7V

## DO11

A	FM 0.6V, MW 5.5V, SW1 0.6V SW2~SW9 0.9V
C	FM-MW 5.7V, SW1~SW6 5.7V SW7 0.2V, SW8~SW9 5.7V

## DO12

A	FM 0.6V, MW 5.5V, SW1 0.6V SW2~SW9 0.9V
C	FM-MW 5.7V, SW1~SW5 5.7V SW6 0.2V, SW7~SW9 5.7V

## DO13

A	FM 0.6V, MW 5.5V, SW1 0.6V SW2~SW9 0.9V
C	FM-MW 5.7V, SW1~SW4 5.7V SW5 0.2V, SW6~SW9 5.7V

## DO14

A	FM 0.6V, MW 5.5V, SW1 0.6V SW2~SW9 0.9V
C	FM-MW 5.7V, SW1~SW3 5.7V SW4 0.2V, SW5~SW9 5.7V

## DO15

A	FM 0.6V, MW 5.5V SW1 0.6V, SW2~SW9 0.9V
C	FM-MW 5.7V, SW1~SW2 5.7V SW3 0.2V, SW4~SW9 5.7V

## DO16

A	FM 0.5V, MW 0.7V SW1 0.9V, SW2~SW9 5.0V
C	FM 4.2V, MW 5.4V SW1 0.2V, SW2~SW9 4.5V

## DO17

A	FM 0.5V, MW 0.7V, SW1 0.9V SW2~SW9 5.0V
C	FM 5.7V, MW 0.2V SW1~SW9 5.7V

## DO18

A	FM 0V, MW 0V, SW1 0V SW2~SW9 1.5V
---	--------------------------------------

## DO19

A	FM 0.3V, MW 0.3, SW1 0.6V SW2 0.8V, SW3~SW9 1.6V
C	FM 5.7V, MW 5.7V, SW1 5.7V SW2 0.2V, SW3~SW9 5.7V

## DO20

A	FM-MW 0.3V, SW1 0.6V, SW2 1.6V SW3 0.8V, SW4~SW9 1.6V
C	FM-MW 5.7V, SW1~SW2 5.7V SW3 0.2V, SW4~SW9 5.7V

## DO21

A	FM-MW 0.3V, SW1 0.6V, SW2~3 1.6V SW4 0.8V, SW5~SW9 1.6V
C	FM-MW 5.7V, SW1~SW3 5.7V SW4 0.2V, SW5~SW9 5.7V

## DO22

A	FM-MW 0.3V, SW1 0.6V, SW2~4 1.6V SW5 0.8V, SW6~SW9 1.6V
C	FM-MW 5.7V, SW1~SW4 5.7V SW5 0.2V, SW6~SW9 5.7V

## DO23

A	FM-MW 0.3V, SW1 0.6V, SW2~5 1.6V SW6 0.8V, SW7~SW9 1.6V
C	FM-MW 5.7V, SW1~SW5 5.7V SW6 0.2V, SW7~SW9 5.7V

## DO24

A	FM-MW 0.3V, SW1 0.6V, SW2~6 1.6V SW7 0.8V, SW8~SW9 1.6V
C	FM-MW 5.7V, SW1~SW6 5.7V SW7 0.2V, SW8~SW9 5.7V

## DO25

A	FM-MW 0.3V, SW1 0.6V SW2~SW7 1.6V, SW8 0.8V, SW9 1.6V
C	FM-MW 5.7V, SW1~SW7 5.7V SW8 0.2V, SW9 5.7V

## DO26

A	FM-MW 0.3V, SW1 0.6V SW2~SW8 1.6V, SW9 0.8V
C	FM-MW 5.7V, SW1~SW8 5.7V SW9 0.2V

## DO27

A</
-----

(F11 MODEL)

### 6. P.C. BOARD PARTS LOCATIONS

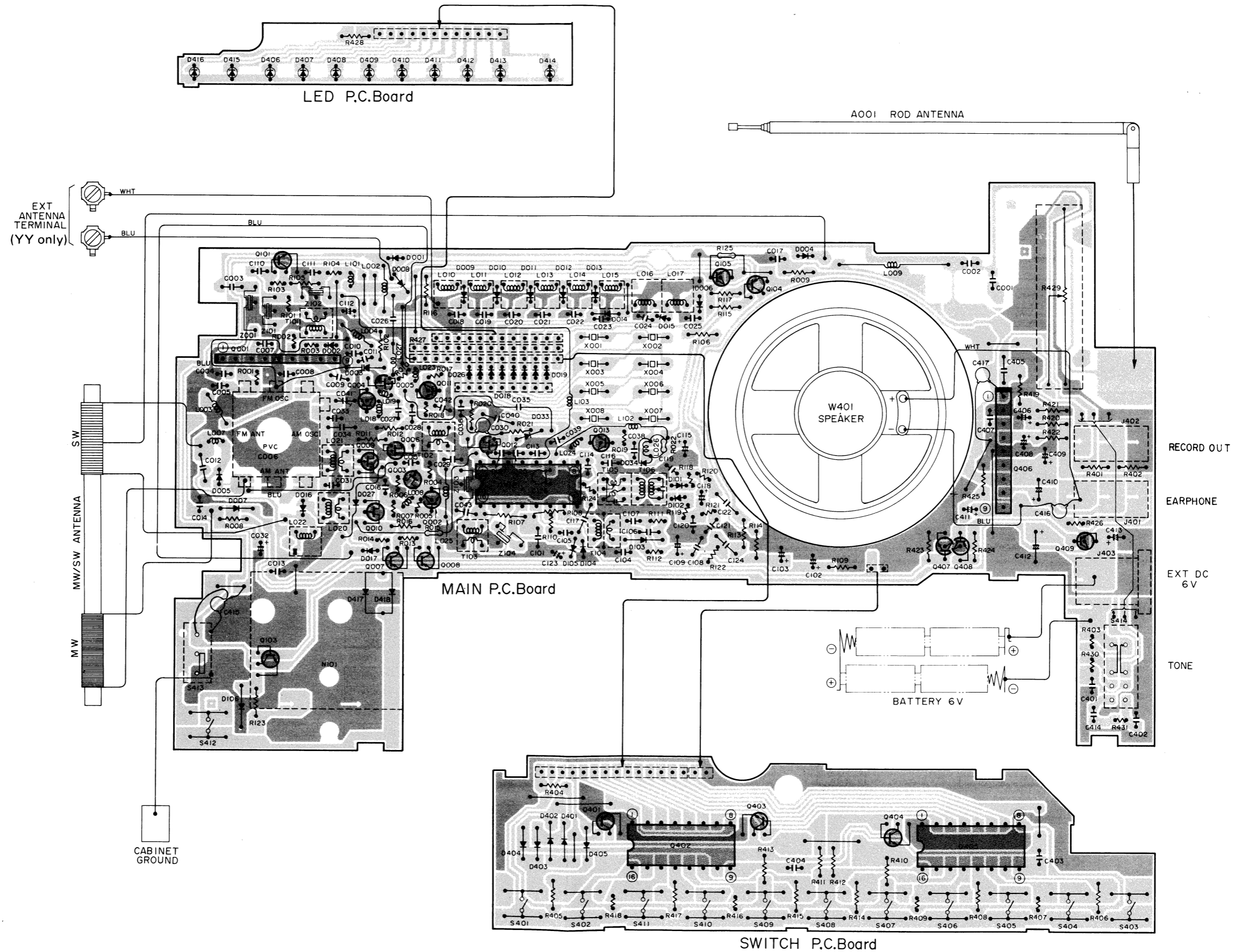
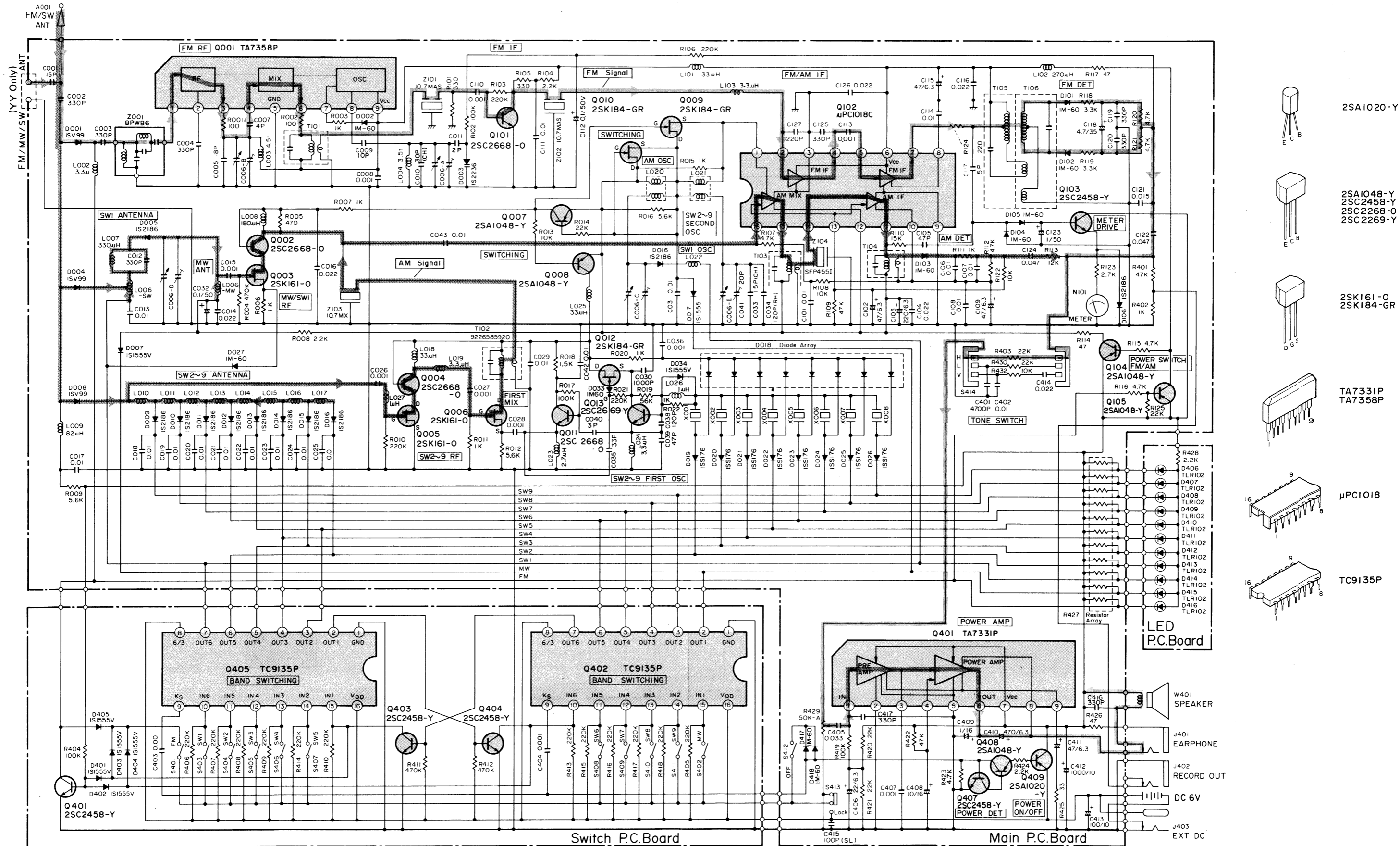

Figure 12

# 7. SCHEMATIC DIAGRAM

(F11 MODEL)



(F11L MODEL)

### 8. P.C. BOARD PARTS LOCATIONS

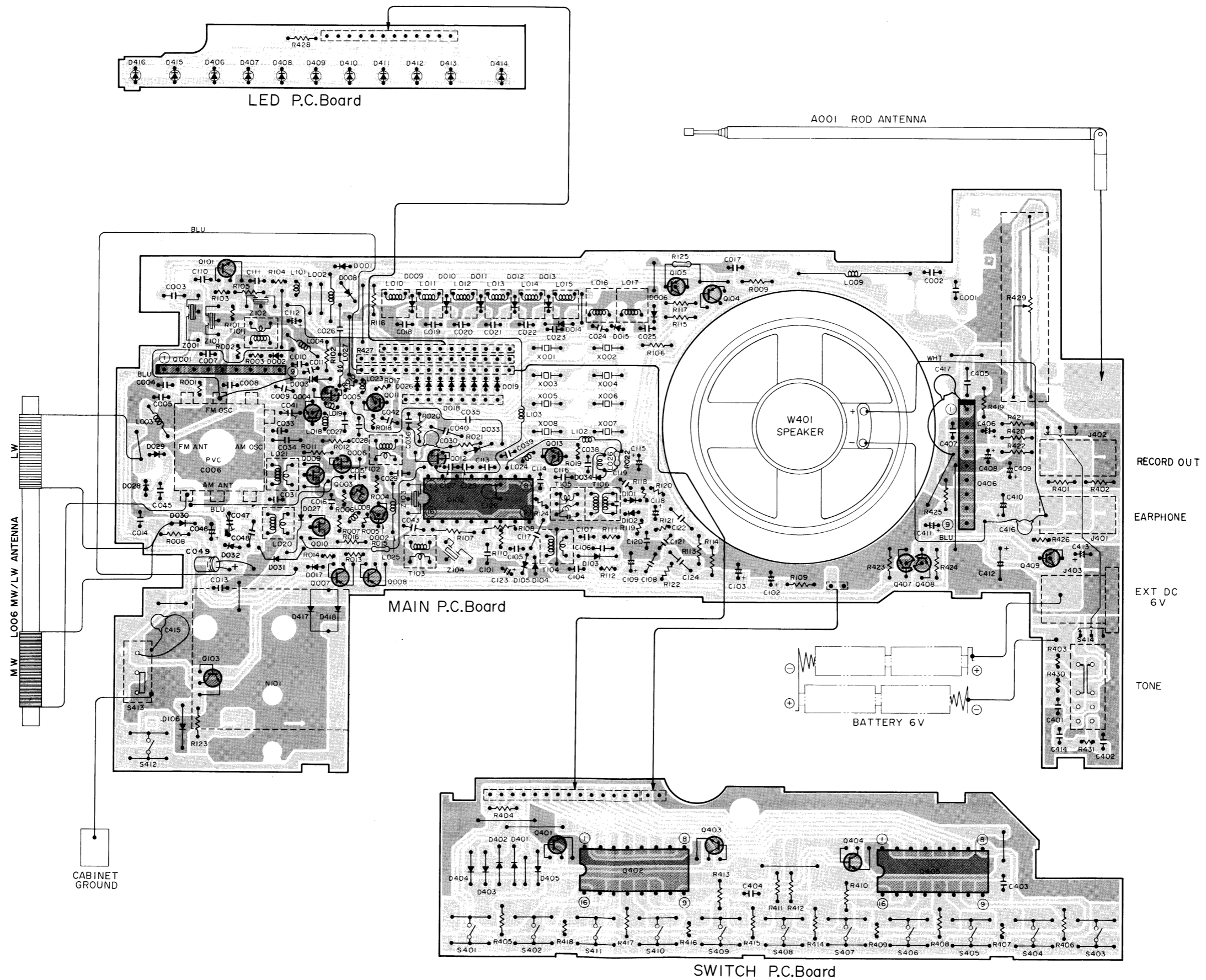

Figure 14

(F11L MODEL)

### 9. SCHEMATIC DIAGRAM

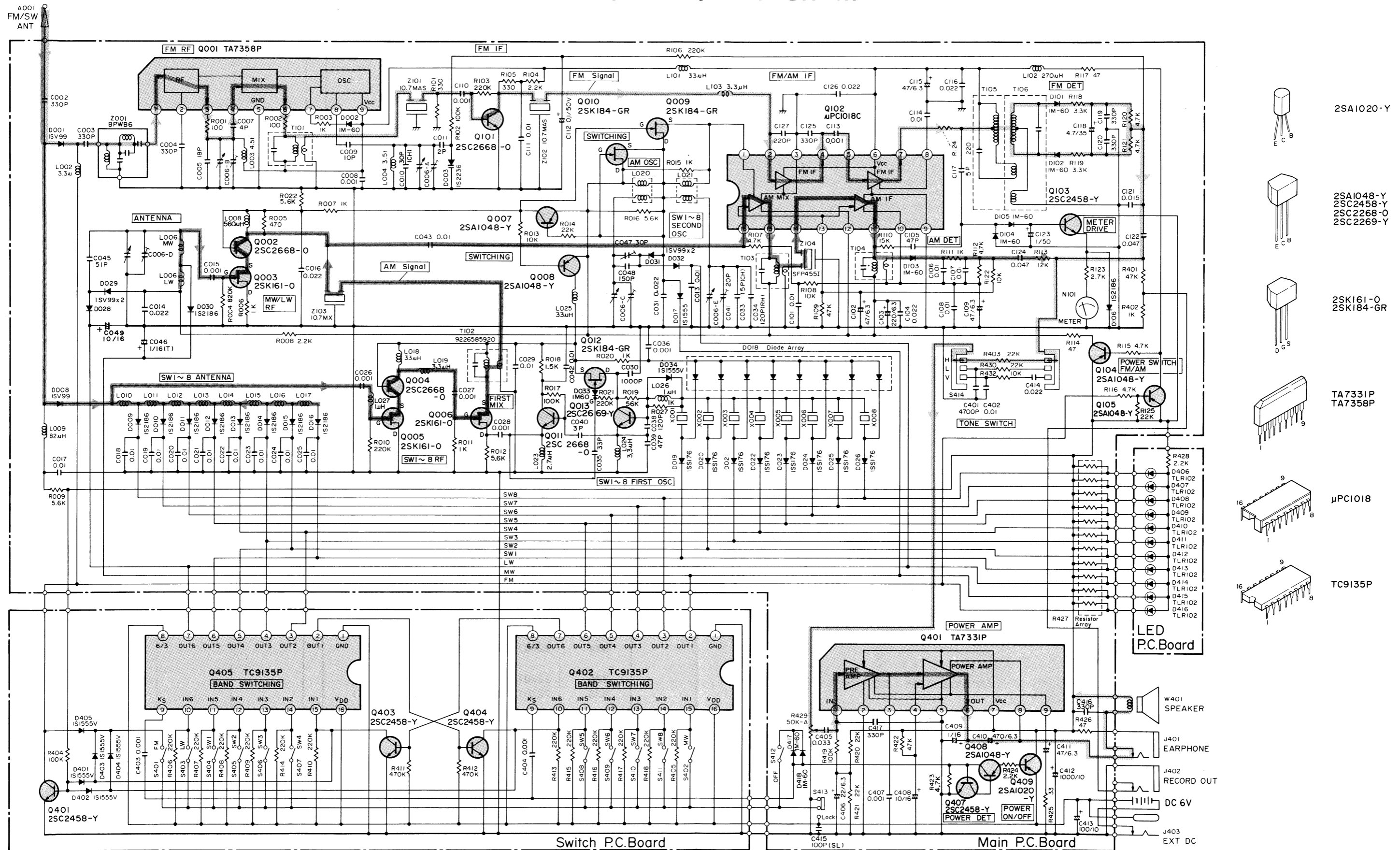
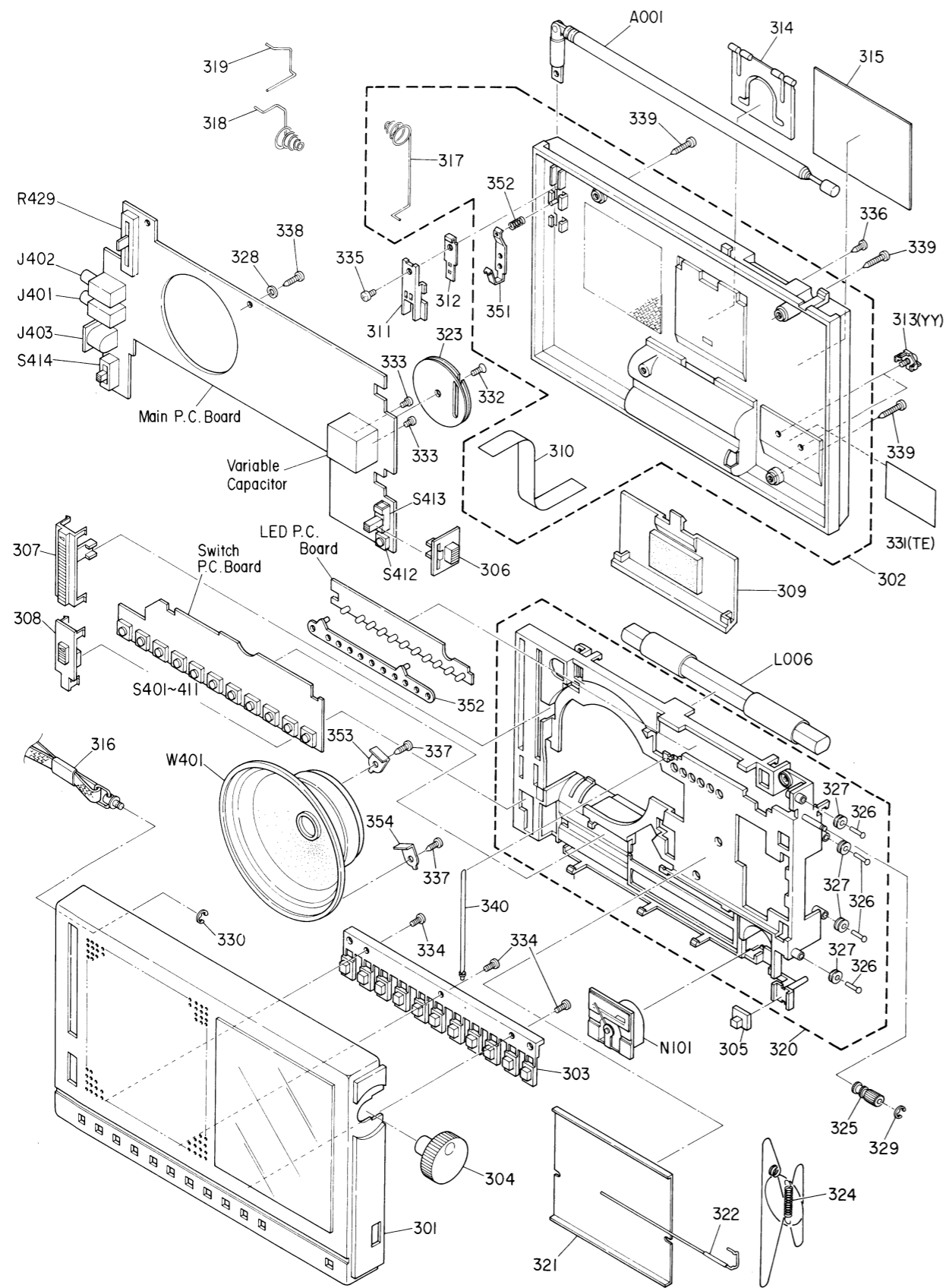

Figure 15

**CAUTION:**

The mark, the symbol No. circled with oval in the schematic diagram and the shaded area in the parts list designate components which have special characteristics important for safety and should be replaced only with types identical to those in the original circuit or specified in the parts list.

### 10-1. EXPLODED VIEW CABINET



### 10-2. CABINET PARTS LIST

Symbol No.	Part No.	Description	Symbol No.	Part No.	Description
301	22881259	Front Cabinet Ass'y (F11-TE,YY)			
301	22881260	Front Cabinet Ass'y (F11L-TE)			
302	22822269	Back Cabinet Ass'y			
303	22884300	Knob, Band Select			
304	22884295	Knob, Tuning			
305	22884296	Knob, Power			
306	22884297	Knob, Safety			
307	22884298	Knob, Volume			
308	22884299	Knob, Tone			
309	22822254	Battery Cover Ass'y			
310	25833327	Ribbon			
311	22746243	Antenna Slider			
312	22757119	Antenna Holder			
313	22759046	Terminal Ass'y, Antenna (YY)			
314	22830246	Stand			
315	22864492	Nameplate (F11-TE)			
315	22864490	Nameplate (F11L-TE)			
316	22993058	Strap Ass'y			
317	25777250	Spring, Battery (+, -)			
318	25777251	Spring, Battery (-)			
319	22725257	Contact, Battery (+)			
320	22714275	Mold Flame Ass'y, with Pulley			
321	22836422	Dial Plate (F11-TE, YY)			
321	22836423	Dial Plate (F11L-TE)			
322	22753149	Pointer			
323	22742302	Drum			
324	22776391	Spring, Drum			
325	22743324	Tuning Shaft			
326	22743325	Rivet, Pulley			
327	22751208	Pulley			
328	25766017	Washer, 3φ			
329	22703118	E Ring, 2φ			
330	22703119	E Ring, 2.5φ			
331	22864489	Plate, FTZ (TE)			
332	22707680	Screw, 1.7φ x 3mm, BID			
333	22707725	Screw, 1.7φ x 2.5mm, PAN			
334	22707298	Screw, 2φ x 6mm, BID Tapping			
335	22707455	Screw, 2.6φ x 5mm, BID			
336	22701338	Screw, 2.6φ x 8mm, BID Tapping			
337	22707301	Screw, 2.6φ x 8mm, BID Tapping			
338	22707303	Screw, 2.6φ x 10mm, BID Tapping			
339	22708034	Screw, 2.6φ x 16mm, BID Tapping			
340	20745105	Cord Ass'y, Dial			

**NOTE:** Parts excluded in the parts list are not stocked since they are seldom required for routine service. Some delay should be anticipated when ordering these items.

Figure 16

## 11. PARTS LIST

Symbol No.	Part No.	Description
<b>IC'S, TRANSISTORS &amp; DIODES</b>		
Q001	B0325500	IC, TA7358P
Q002, 004	A6332530	Transistor, 2SC2668-O
Q003, 005, 006	A6042620	Transistor, 2SK161-O
Q007, 008	A6534430	Transistor, 2SA1048-Y
Q009, 010, 012	A6046844	Transistor, 2SK184-GR
Q011	A6332530	Transistor, 2SC2668-O
Q013	A6332630	Transistor, 2SC2669-Y
Q101	A6332530	Transistor, 2SC2668-O
Q102	22114701	IC, $\mu$ PC1018C
Q103	A6332430	Transistor, 2SC2458-Y
Q104, 105	A6534430	Transistor, 2SA1048-Y
Q401, 403, 404, 407	A6332430	Transistor, 2SC2458-Y
Q402, 405	B0411350	IC, TC9135P
Q406	B0325200	IC, TA7331P
Q408	A6534430	Transistor, 2SA1048-Y
Q409	A6534125	Transistor, 2SA1020-Y
D001, 008	A7288680	Diode, 1SV99
D002	22115863	Diode, 1M60
D003	A7289000	Diode, 1S2236
D004	A7288680	Diode, 1SV99 (F11-TE, YY)
D005, 016	A7288620	Diode, 1S2186-GR (F11-TE, YY)
D006, 009, 010, 011, 012, 013, 014, 015	A7288620	Diode, 1S2186-GR
D007	A7246703	Diode, 1S1555V (F11-TE, YY)
D017	A7246703	Diode, 1S1555V
D018	22130714	Composite Part, 1SS176 x 8
D019, 020, 021, 022, 023, 024, 025, 026	A7160570	Diode, 1SS176
D027	22115863	Diode, 1M60 (F11-TE, YY)
D028, 029, 031, 032	A7288680	Diode, 1SV99 (F11L-TE)
D030	A7288620	Diode, 1S2186-GR (F11L-TE)
D033	22115863	Diode, 1M60

Symbol No.	Part No.	Description
D101, 102, 103, 104, 105	22115863	Diode, 1M60
D106, 107	A7288620	Diode, 1S2186-GR
D401, 402, 403, 404, 405	A7246703	Diode, 1S1555V
D406, 407, 408, 409, 410, 411, 412, 413, 414, 415, 416	A8600050	Diode, TLR102, LED RED
D417	22115863	Diode, 1M60
<b>COILS &amp; TRANSFORMERS</b>		
L002	22291147	Coil, Choke, 3.3 $\mu$ H
L003	22292182	Coil, FM RF
L004	22295157	Coil, FM OSC (F11-TE, YY)
L004	22295158	Coil, FM OSC (F11L-TE)
L006	22242971	Coil, MW/SW Antenna (F11-TE, YY)
L006	22242979	Coil, LW/MW Antenna (F11L-TE)
L007	22291171	Coil, Choke, 330 $\mu$ H (F11-TE, YY)
L008	22291168	Coil, Choke, 180 $\mu$ H
L009	22291198	Coil, Choke, 82 $\mu$ H
L010	22242963	Coil, SW Antenna 9
L011, 012, 013	22242966	Coil, SW Antenna 8, 7, 6
L014	22242967	Coil, SW Antenna 5
L015	22242968	Coil, SW Antenna 4
L016, 017	22242970	Coil, SW Antenna 3, 2
L018, 025	22291159	Coil, Choke, 33 $\mu$ H
L019, 024	22291147	Coil, Choke, 3.3 $\mu$ H
L020	22245434	Coil, MW OSC
L021	22245436	Coil, SW2 ~ 9 OSC 2
L022	22245435	Coil, SW1 OSC (F11-TE-YY)
L023	22291146	Coil, Choke, 2.7 $\mu$ H

Symbol No.	Part No.	Description
L026, 027	22291141	Coil, Choke, 1 $\mu$ H
L101	22291159	Coil, Choke, 33 $\mu$ H
L102	22291170	Coil, Choke, 270 $\mu$ H
T101, 102	22265859	IF Transformer, FM, SW
T103	22264803	IF Transformer, AM
T104	22266366	IF Transformer, AM DET
T105	22267380	IF Transformer, FM
T106	22267381	IF Transformer, FM
<b>ELECTRICAL PARTS</b>		
S401, 402, 403, 404, 405, 406, 407, 408, 409, 410, 411, 412	22196069	Key Switch, Band, FM, MW SW1, SW2 SW3, SW4 SW5, SW6 SW7, SW8 SW9, OFF
S413	22195752	Slide Switch, Power
S414	22196294	Slide Switch, Tone
J401, 402	22163842	Jack, Earphone, Record, 3.5 $\phi$
J403	22163898	Jack, Power
X001	22153284	Crystal, 16.75 MHz
X002	22153285	Crystal, 17.95 MHz
X003	22153286	Crystal, 20.35 MHz
X004	22153287	Crystal, 22.55 MHz
X005	22153288	Crystal, 24.45 MHz
X006	22153289	Crystal, 26.05 MHz
X007	22153290	Crystal, 28.45 MHz
X008	22153291	Crystal, 32.35 MHz
Z001	22153222	Filter, FM Band pass
Z101, 102	22153058	Filter, Ceramic, 10.7 MS
Z103	22153283	Filter, Ceramic, 10.7 MX
Z104	22153282	Filter, Ceramic, 4601
A001	22124505	Rod Antenna
N101	22104592	Meter, Tuning
W401	22152457	Speaker, 8cm

Symbol No.	Part No.	Description
<b>CAPACITORS</b>		
D = $\pm 0.5\mu$ F, J = $\pm 5\%$ , K = $\pm 10\%$ , M = $\pm 20\%$		
ABBREVIATIONS: CD = Ceramic Disk, BL = Barrier Layer		
EL = Electrolytic, TT = Tantalum		
C001	22361150	CD, 15pF, 50V, J (F11-TE)
C002, 003	22349331	CD, 330pF, 50V, K
C004	22349331	CD, 330pF, 50V, K
C005	22361180	CD, 18pF, 50V, J
C006	22308572	Variable
C007	22361409	CD, 4pF, 50V, J
C008	22360366	CD, 1000PF, 50V, K
C009	22361100	CD, 10pF, 50V, D
C010	22360756	CD, 30pF, 50V, J, CH
C011	22361209	CD, 2pF, 50V, D
C012	22362331	CD, 330pF, 50V, K (F11)
C013	22360713	BL, 0.01mfd, 16V, M
C014	22360715	BL, 0.022mfd, 16V, M
C015	22360366	CD, 1000pF, 50V, K
C016	22360715	BL, 0.022mfd, 16V, M
C017, 018	22360713	BL, 0.01mfd, 16V, M
C019, 020	22360713	BL, 0.01mfd, 16V, M
C021, 022	22360713	BL, 0.01mfd, 16V, M
C023, 024	22360713	BL, 0.01mfd, 16V, M
C025	22360713	BL, 0.01mfd, 16V, M
C026	22360366	CD, 1000pF, 50V, K
C027, 028	22360366	CD, 1000pF, 50V, K
C029	22360713	BL, 0.01mfd, 16V, M
C030	22360366	CD, 1000pF, 50V, K
C031	22360713	BL, 0.01mfd, 16V, M (F11)
C031	22360715	BL, 0.022mfd, 16V, M (F11L)
C032	22440439	EL, 0.1mfd, 50V (F11)
C033	22360132	CD, 15pF, 50V, J, CH
C034	22360751	CD, 120pF, 50V, J, RH
C035	22360733	CD, 33pF, 50V, J
C036	22360366	CD, 1000pF, 50V, K
C038	22362121	CD, 120pF, 50V, K
C039	22361470	CD, 47pF, 50V, K
C040	22361309	CD, 3pF, 50V, D
C041	22309192	Trimmer, 20pF
C042, 043	22360713	BL, 0.01mfd, 16V, M
C045	22361510	CD, 51pF, 50V, J (F11L)
C046	22490068	TT, 1mfd, 16V (F11L)
C047	22309193	Trimmer, 30pF, (F11L)
C048	22362151	CD, 150pF, 50V, K (F11L)
C049	22440276	EL, 10mfd, 16V (F11L)



Symbol No.	Part No.	Description
C101	22360713	BL, 0.01mfd, 16V, M
C102	22440279	EL, 47mfd, 6.3V
C103	22440634	EL, 220mfd, 6.3V, M
C104	22360715	BL, 0.022mfd, 16V, M
C105	22361470	CD, 47pF, 50V, K
C106, 107	22360713	BL, 0.01mfd, 16V, M
C108	22360713	BL, 0.01mfd, 16V, M
C109	22440279	EL, 47mfd, 6.3V
C110	22360366	CD, 1000pF, 50V, K
C111	22360713	BL, 0.01mfd, 16V, M
C112	22440439	EL, 0.1mfd, 50V
C113	22360366	CD, 1000pF, 50V, K
C114	22360713	BL, 0.01mfd, 16V, M
C115	22440279	EL, 47mfd, 6.3V
C116	22360715	BL, 0.022mfd, 16V, M
C117	22361509	CD, 5pF, 50V, D
C118	22440275	EL, 4.7mfd, 25V
C119, 120	22349331	CD, 330pF, 50V, K
C121	22360714	BL, 0.015mfd, 16V, M
C122	22360717	BL, 0.047mfd, 16V, M
C123	22440272	EL, 1mfd, 50V
C124	22360717	BL, 0.047mfd, 16V, M
C125	22349331	CD, 330pF, 50V, K
C126	22360715	BL, 0.022mfd, 16V, M
C127	22349221	CD, 220pF, 50V, K
C401	22360725	BL, 4700pF, 25V, M
C402	22360713	BL, 0.01mfd, 16V, M
C403, 404	22360366	CD, 1000pF, 50V, K
C405	22360716	BL, 0.033mfd, 16V, M
C406	22440277	EL, 22mfd, 6.3V
C407	22360366	CD, 1000pF, 50V, K
C408	22440276	EL, 10mfd, 16V
C409	22490068	TT, 1mfd, 16V
C410	22440639	EL, 470mfd, 6.3V
C411	22440279	EL, 47mfd, 6.3V
C412	22440466	EL, 1000mfd, 10V
C413	22440240	EL, 100mfd, 10V
C414	22360715	BL, 0.022mfd, 16V, M
C415	22362101	CD, 100pF, 50V, J
C416	22349331	CD, 330pF, 50V, K
C417	22349331	CD, 330pF, 50V, K

Symbol No.	Part No.	Description
<b>RESISTORS</b>		
All resistors are carbon film, 1/6W, ±5% unless otherwise noted.		
R001, 002	22550169	100 ohm, 1/8W
R003	22550181	1K ohm, 1/8W
R004	22550213	470K ohm, 1/8W (F11)
R004	22550216	820K ohm, 1/8W (F11L)
R005	22550177	470 ohm, 1/8W
R006, 007	22550181	1K ohm, 1/8W
R008	22584222	2.2K ohm (F11)
R008	22584562	5.6K ohm (F11L)
R009	22584562	5.6K ohm
R010	22550208	220K ohm 1/8W
R011	22584102	1K ohm
R012	22584562	5.6K ohm
R013	22550192	10K ohm, 1/8W
R014	22550196	22K ohm, 1/8W
R015	22584102	1K ohm
R016	22584562	5.6K ohm
R017	22550204	100K ohm, 1/8W
R018	22550415	1.5K ohm, 1/8W
R019	22550201	56K ohm, 1/8W
R020	22584102	1K ohm
R021	22550208	220K ohm, 1/8W
R101	22550175	330 ohm, 1/8W
R102	22584104	100K ohm
R103	22550208	220K ohm, 1/8W
R104	22550185	2.2K ohm, 1/8W
R105	22584331	330 ohm
R106	22584224	220K ohm
R107	22584472	4.7K ohm
R108	22584103	10K ohm
R109	22584473	47K ohm
R110	22550194	15K ohm, 1/8W
R111	22550181	1K ohm, 1/8W
R112	22550189	4.7K ohm, 1/8W
R113	22584123	12K ohm, 1/8W
R114	22584470	47 ohm
R115, 116	22584472	4.7K ohm
R117	22584470	47 ohm
R118, 119	22550187	3.3K ohm, 1/8W
R120, 121	22550189	4.7K ohm, 1/8W
R122	22550192	10K ohm, 1/8W
R123	22584272	2.7K ohm
R124	22570386	220 ohm, 1/16W, Metal Film
R125	22584223	22K ohm

