

SERVICE DATA

MODEL WR-4000

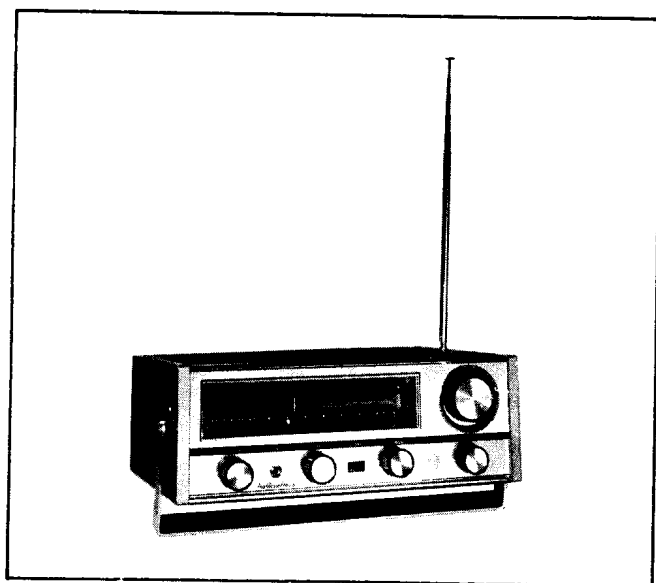

156-007016

Figure 1. Hallicrafters' Model WR-4000 Receiver.

TECHNICAL SPECIFICATIONS.

FREQUENCY COVERAGE

LW	180 KC to 400 KC
BC	535 KC to 1650 KC
SW1	2 MC to 4 MC
SW2	5.85 MC to 10.3 MC
SW3	11.4 MC to 18.2 MC
FM	86.5 MC to 108 MC

TRANSISTORS

Fourteen, plus six diodes and 2 Zener diode regulators.

Speaker

4 x 6 inch PM, 3.2-ohm voice coil.

ANTENNAS

Provisions for single wire or 50 to 600 ohm line.

LW and BC Self-contained ferrite rod.

SW and FM Telescoping rod antenna.

POWER SUPPLY

12 volts DC (eight 1-1/2 volt D cells); a separate D cell to provide power for dial lamps.

INTERMEDIATE FREQUENCY (IF)

455KC on AM bands.

10.7MC on FM band.

PHONES JACK

Accepts standard miniature-type phone plug.

HEADPHONE IMPEDANCE

3 to 3000 ohms.

POWER OUTPUT

Up to 500 milliwatts undistorted.

DIMENSIONS (HWD)

4-1/8 by 11-1/2 by 8 inches.

NET WEIGHT

10.5 pounds.

SHIPPING WEIGHT

12 pounds.

BATTERY REPLACEMENT.

After the receiver is unpacked, place the receiver with the panel facing you. Remove the top cover by removing the two top mounting feet. Disconnect the battery plug near the left side of the chassis, then gently pull up on the cloth tape at the center of the battery pack, lifting the battery pack from the receiver. (See Detail "A" of Figure 2.)

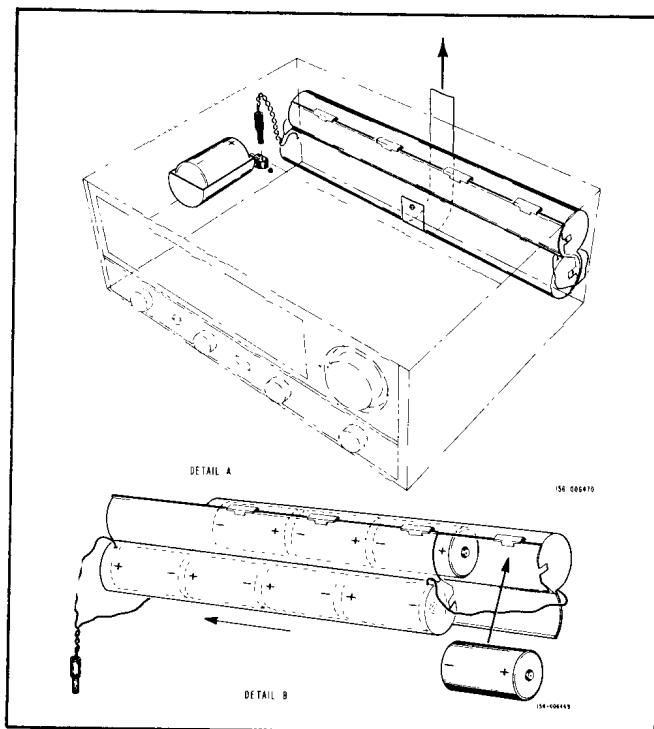

Figure 2. Battery Replacement Detail.

Slide the upper part of the battery pack against the lower part (see Detail "B" of Figure 2) and carefully install the eight D-size cells.

IMPORTANT

IT IS ESSENTIAL THAT THE BATTERIES BE INSTALLED IN THE CORRECT MANNER AS SHOWN IN DETAIL "B" OF FIGURE 2. IMPROPER BATTERY INSTALLATION MAY CAUSE EXTENSIVE DAMAGE TO THE RECEIVER.

When replacing defective batteries, care should be taken when removing the battery pack from the receiver. The batteries in the pack are under a certain amount of spring tension and if the cover latch is accidentally snapped during removal the batteries may pop out.

An additional D-size cell is provided for the dial lamps. This battery should be installed as shown in Detail A, of Figure 2.

CHASSIS REMOVAL.

Position the receiver so that the front panel faces you. Remove the top cover by removing the two top mounting feet. Remove the battery pack and all the knobs. Remove the phillips-head screws on the two rear corners of the chassis and in the right front corner. Locate and remove the phillips head screw on the left side of the chassis directly behind the dial drum bracket. Remove the wire connected to the antenna terminal board (TS1). Grasp the chassis firmly at the rear with either hand and lift it back and up in a circular motion until the chassis is free of the cabinet.

DIAL CORD RESTRINGING.

To replace either dial cord, the chassis must be removed from the cabinet as described in the CHASSIS REMOVAL paragraph.

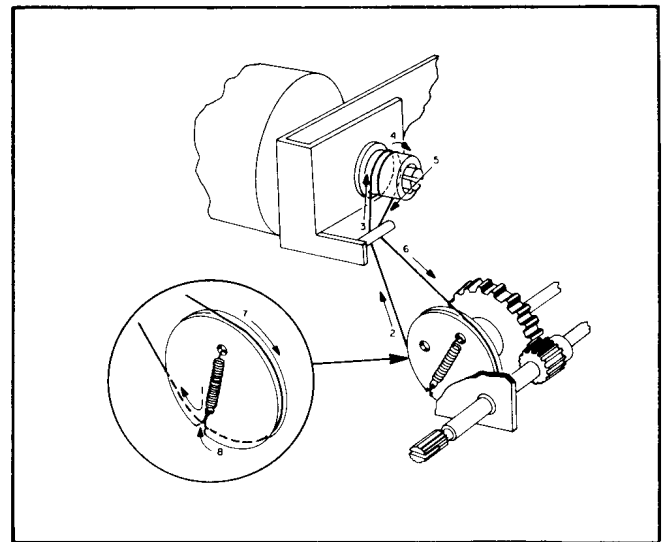

156-007007

Figure 3. Restringing the Dial Drum.

To restring the dial drum, set the BAND SELECTOR to the FM position and follow the numerical sequence shown in figure 3. The dial cord spring should be expanded approximately one-quarter inch to maintain proper spring tension.

To restring the TUNING gang, set the TUNING control fully counterclockwise and follow the numerical sequence shown in figure 4. The dial cord spring should be expanded one-quarter to one-half inch to maintain the proper spring tension. Engage the dial cord with the pointer clips and position the pointer over the mark on the left side of the dial scale. Apply a drop of cement to the dial cord and pointer clip.

When all necessary dial cord restringing has been completed, replace the chassis in the cabinet.

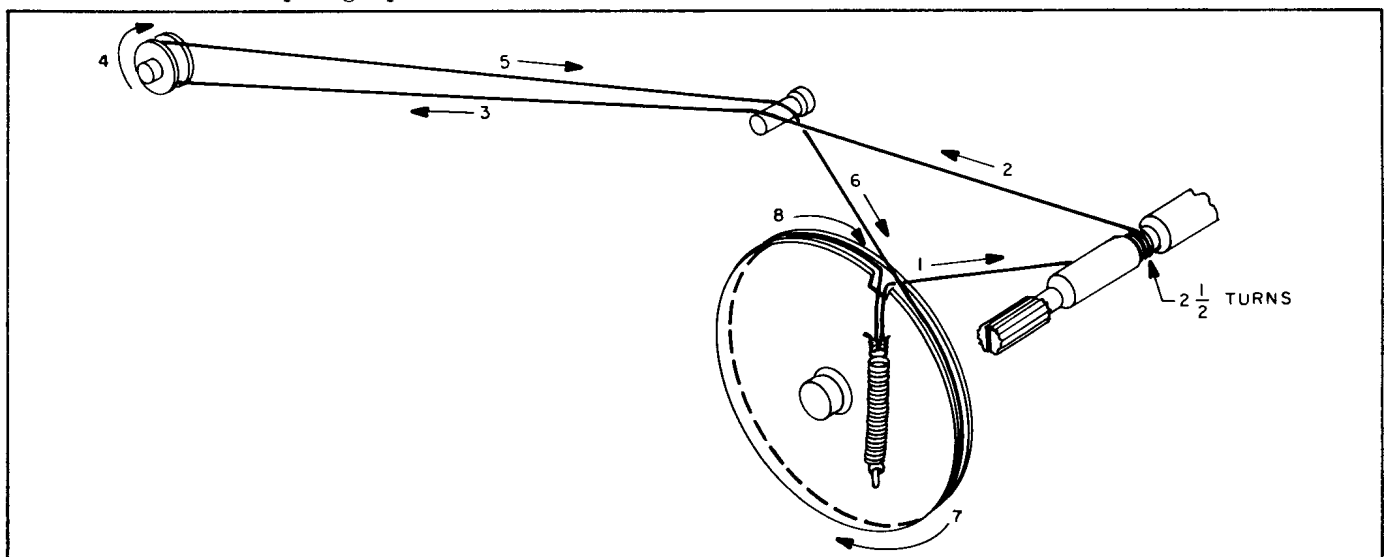

156-007008

Figure 4. Restringing the Tuning Dial Pointer.

SERVICE REPAIR PARTS LIST

Schematic Symbol	Description	Hallcrafters Part Number	Schematic Symbol	Description	Hallcrafters Part Number	Schematic Symbol	Description	Hallcrafters Part Number
CAPACITORS			CAPACITORS (CONT.)			TRANSISTORS AND DIODES		
C1A,B,C, D,E,F,G,H, C2,16	Variable TUNING 4.5 PF, ±0.5 PF, 50 V, Ceramic	120-002206	C103	1μF, +200%, -10%, 10V, Electrolytic	120-002291	Q1	Transistor, Type 2SA434	120-002215
C3,44,55, 70,78	30 PF, ±5%, 50 V, Ceramic	120-002267	C105	0.05μF, ±20%, 5V, Mylar	120-002290	Q2,3	Transistor, Type 2SA235	120-002214
C5,24	6 PF, ±0.5 PF, 50 V, Ceramic	120-002256	C107	5μF, +200%, -10%, 10V, Electrolytic	120-002293	Q4,5,6,8,9	Transistor, Type 2SA234	120-002213
C6,19	0.02μF, +80%, -20%, 30V, Ceramic	120-002257	C108	100μF, +150%, -10%, 12V, Electrolytic	120-002294	Q7	Transistor, Type 2SA350R	120-002216
C7,49,92	7 PF, ±0.5 PF, 50 V, Ceramic	120-002258	C106	0.1 μF, Electrolytic	120-002292	Q10	Transistor, Type 2SA12A	120-001192
C10,12,38	0.001μF, +100%, -0%, 50V, Ceramic	120-002259	* RESISTORS			Q11,12	Transistor, Type 2SB75B	120-002013
C11	5 PF, ±0.5 PF, 50V, Ceramic	120-002263	R1	250 ohm, ±5%	120-002302	Q13,14	Transistor, Type 2SB77B	120-001195
C14	10 PF, ±1%, 50V, Ceramic	120-002265	R2	500 ohm, ±5%	120-002231	CR1,3,4, 5,6,7	Diode, Type 1N34A	120-002217
C15	0.01μF, +80%, -20%, 50V, Ceramic	120-002264	R3,8,11,13	30K ohm, ±5%	120-002228	MISCELLANEOUS		
C17,32	3 PF, ±0.25 PF, 50V, Ceramic	120-002260	R4,12,25	100 ohm, ±5%	120-002229	Antenna, Rod		120-002210
C18,25,27, 30	500 PF, ±5%, 50V, Ceramic	120-002261	R5	1 megohm, ±5%	120-002232	Battery Case, Main		120-002174
C20,21,22, 23,28,29, 34	2 PF, ±0.25 PF, 50V, Ceramic	120-002284	R6	70K ohm, ±5%	120-002233	Battery Case, Pilot Lamp		120-002175
C26,31,36, 88,93,95, 98,99,101	0.04μF, +80%, -20%, 30V, Ceramic	120-002272	R7	500 K ohm, ±5%	120-002247	Biss and Nut		120-002221
C33,94,109	30μF, +200%, -10%, 3V, Electrolytic	120-002274	R9	300 ohm, ±5%	120-002234	Bracket, Printed Circuit Board		120-002176
C35	8 PF, ±1 PF, 50 V, Ceramic	120-002285	R10,27,28	1K ohm, ±5%	120-002227	Carton, Individual		120-002223
C37	3.5 PF, ±0.25 PF, 50 V, Ceramic	120-002286	R14,23	40K ohm	120-002732	PC1,3	Couplet	120-002295
C39,53,65, 96,113	0.02μF, ±20%, 50 V, Mylar	120-002269	R16	25K ohm	120-002246	PC2,12	Couplet	120-002296
C40	50μF, +200%, -10%, 3V, Electrolytic	120-002288	R17,21,33, 41,54	50K ohm	120-002237	PC4,6,9	Couplet	120-002298
C41,102, 104	5μF, +200%, -10%, 3 V, Electrolytic	120-002289	R18,42,44	30K ohm	120-002236	PC5,7	Couplet	120-002299
C42	0.1μF, ±20%, 50 V, Mylar	120-002728	R19,45,50, 55,64	50K ohm	120-002242	PC8	Couplet	120-002300
C43	250 PF, ±5%, 50V, Ceramic	120-002266	R20,24,35, 36,40,43, 52,56	500 ohm	120-002240	PC10	Couplet	120-002301
C45A,B,C	Variable, Trimmer	120-002218	R22	15K ohm	120-002733	PC11	Couplet	120-002297
C46	100 PF, ±5%, 50 V, Ceramic	120-002268	R26,30,31, 39,51,62	1K ohm	120-002235	CR2,8	Cover, Cabinet Diode, Zener	120-002164 120-002219
C48A,B,C, D	Variable, Trimmer	120-002208	R29	50K ohm, ±5%	120-002303	Drum, Dial		120-002172
C51,61,63	20 PF, ±5%, 50V, Ceramic	120-002255	R32	300 ohm	120-002738	Drum Pulley		120-002188
C54,88	300 PF, ±5%, 50V, Ceramic	120-002270	R37	20K ohm	120-002241	Gear (4)		120-002189
C56A,B, C,D	Variable, Trimmer	120-002208	R38	2K ohm	120-002734	Glass, Dial		120-002171
C57,74,86	70 PF, ±5%, 50V, Ceramic	120-002278	R46	10K ohm	120-002244	Handle		120-002187
C59	40PF, ±5%, 50V, Ceramic	120-002271	R47	250 ohm	120-002243	Holder, Core		120-002185
C60A,B, C,D	Variable, Trimmer	120-002208	R49	7K ohm	120-002248	Jack, PHONES		120-002212
C66	Variable, VERNIER	120-002207	R53	100 ohm	120-002249	Knob, BAND SELECTOR		120-002170
C67	15 PF, ±5%, 50V, Ceramic	120-002729	R57	30 ohm	120-002250	Knob, TONE, VERNIER, and VOLUME		120-002169
C69	500 PF, ±5%, 50V, Styrole	120-002276	R59	4K ohm	120-002251	Knob, TUNING		120-002168
C72	6500 PF, ±10%, 50V, Styrole	120-002277	R60	130 ohm	120-002252	Lamp, Pilot		120-002211
C73,76	2000 PF, ±10%, 50V, Styrole	120-002279	R61	2 ohm, 1/4 watt	120-002253	Overlay, Front Panel		120-002165
C77,81,110, 111	0.01μF, ±20%, 50V, Mylar	120-002280	R63	Variable, 5K ohm, VOLUME	120-002205	Overlay, Vinyl Left		120-002162
C80	370 PF, ±5%, 50V, Ceramic	120-002281	R58	100 ohm, 1/4 watt	120-002750	Overlay, Vinyl Right		120-002163
C82	25 PF, ±5%, 50V, Ceramic	120-002730	*Unless otherwise specified, all RESISTORS are carbon type, 10%, 1/8 watt.			Plate, Shield		120-002226
C84,97	180 PF, ±5%, 50V, Ceramic	120-002282	COILS AND TRANSFORMERS			Pointer, Dial		120-002173
C85,91	0.04μF, ±20%, 50V, Mylar	120-002273	L1	Coil, Antenna (LW,BC)	120-002191	Printed Circuit Board (A)		120-002180
C89	100μF, +200%, -10%, 10V, Electrolytic	120-002283	L2,3,4	Coil, Antenna (SW1,2,3)	120-002192	Printed Circuit Board (B)		120-002181
C90	0.1μF, +80%, -20%, 25V, Ceramic	120-002731	L5,8,9,10, 23,24	Coil, Choke	120-002198	Printed Circuit Board (C)		120-002182
C100,112	100μF, +150%, -10%, 12V, Electrolytic	120-002275	L6	Coil, Antenna (FM)	120-002193	Printed Circuit Board (D)		120-002183
			L7	Coil, RF	120-002735	Printed Circuit Board (E)		120-002184
			L11	Coil, Oscillator (FM)	120-002736	Pulley (2)		120-002187
			L12,13,14, 15,16	Coil, RF	120-002195	Radiator		120-002225
			L17,18,19, 20,21	Coil, Oscillator	120-002194	Rail		120-002179
			L22	Coil, BFO	120-002201	Spacer (2)		120-002190
			T14	Transformer, Output	120-002200	Shaft, Drive (set)		120-002186
			T1,2,3,4, 7,8	Transformer, 1F, FM	120-002197	Shield, Bottom Case		120-002178
			T5,6,9, 11,12	Transformer, 1F, AM	120-002196	Shield, Top Case		120-002177
			T10	Transformer, Ratio Det.	120-002737	Shield Plate		120-002226
			T13	Transformer, Driver	120-002199	Speaker		120-002209
						S1	Switch, BAND SELECTOR	120-002203
						S2	Switch, TONE	120-002202
						S3	Switch, LIGHT	120-002204
						RT1	Terminal Plate, Antenna	120-002224
							Thermistor	120-002220
							Trim, Cabinet	120-002166
							Wiring Material	120-002222
							Wrapper Case	120-002161

PRINTED CIRCUIT BOARD-E

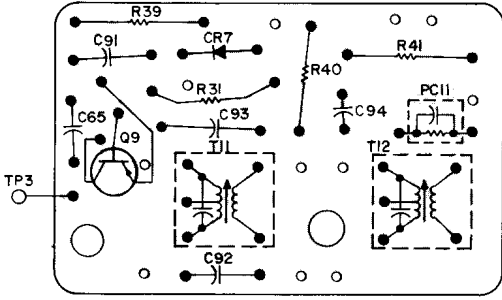

NOTE:
WIRING IS SHOWN FROM
FOIL SIDE OF BOARD.

156-006964

PRINTED CIRCUIT BOARD-D

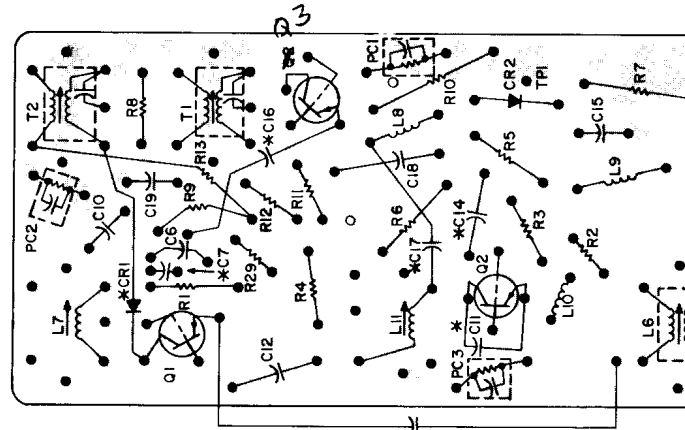
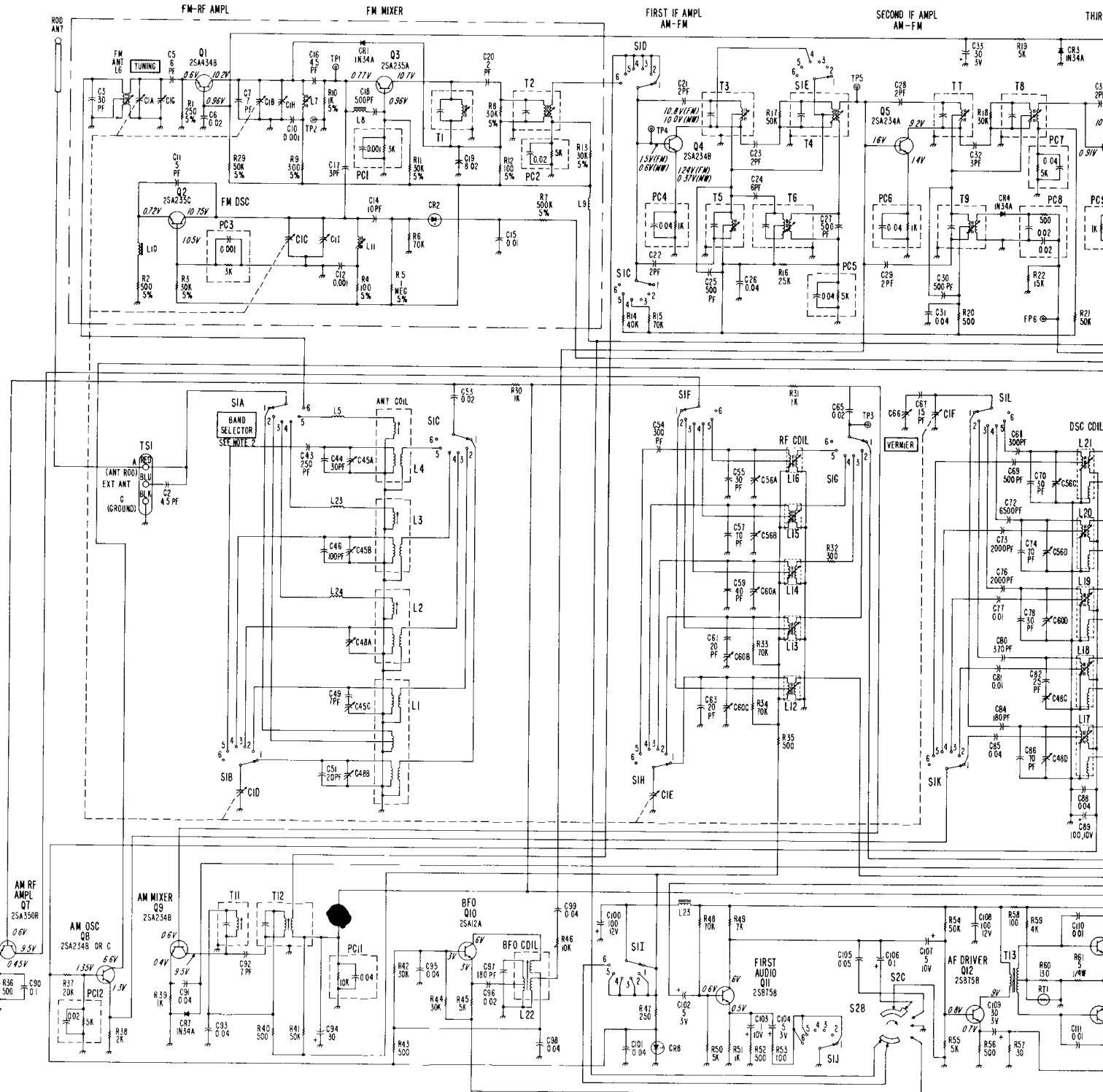
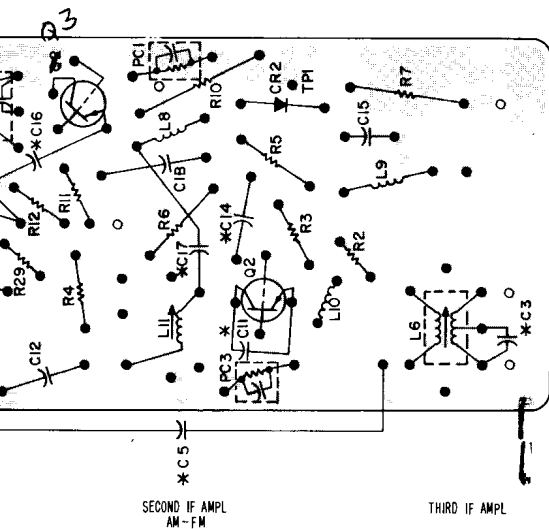

Figure 5. WR-4000 Schematic Diagram.





NOTE:
 WIRING IS SHOWN FROM
 FOIL SIDE OF BOARD.
 * INDICATES COMPONENT MOUNTED
 ON FOIL SIDE OF BOARD.

156-006965

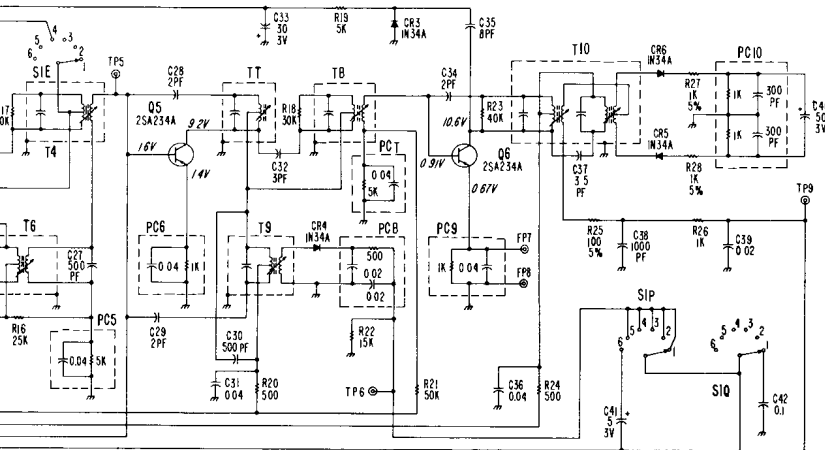

NOTES:

- UNLESS OTHERWISE SPECIFIED:
 ALL RESISTORS ARE IN OHMS, ±10%, 1/8 WATT
 ALL CAPACITORS ARE IN MICROFARADS.
 (SEE PARTS LIST FOR VOLTAGE RATINGS.)
 - ALL WAFERS OF BAND SELECTOR SWITCH S1 ARE
 MECHANICALLY GANGED. SWITCH POSITIONS FOR S1
 ARE SHOWN BELOW
- | BAND SELECTOR | |
|---------------|-----|
| POSITION | |
| 1 | LW |
| 2 | BC |
| 3 | SW1 |
| 4 | SW2 |
| 5 | SW3 |
| 6 | FM |
- ALL WAFERS OF TONE SWITCH S2 ARE MECHANICALLY
 GANGED. S2 SHOWN IN LOW TONE POSITION (EXTREME
 CW)
 - ALL VOLTAGES ARE NEGATIVE VALUES MEASURED
 WITH RESPECT TO GROUND.

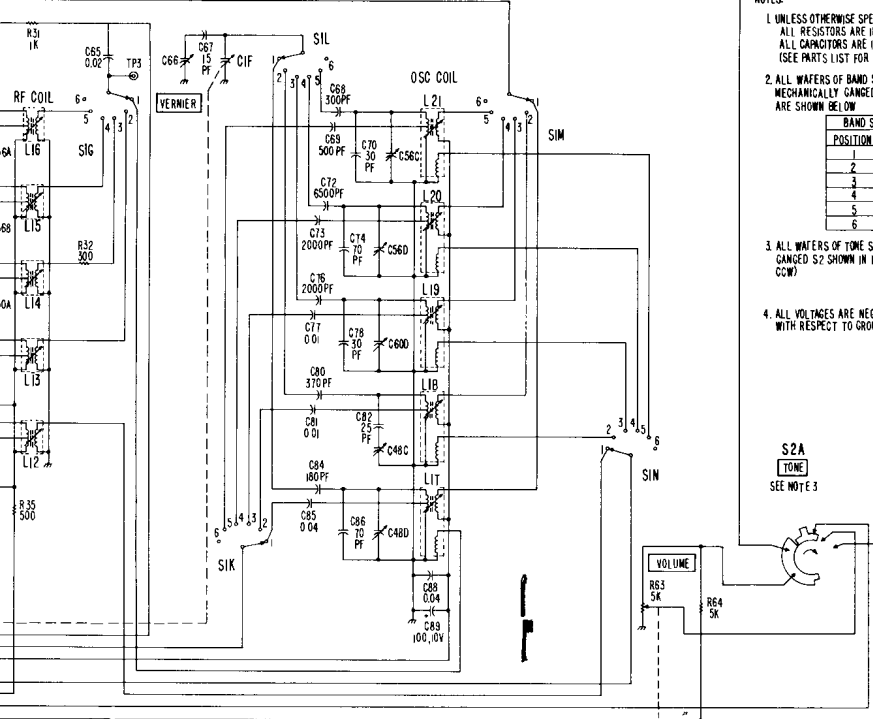

S2A
 TONE
 SEE NOTE 3

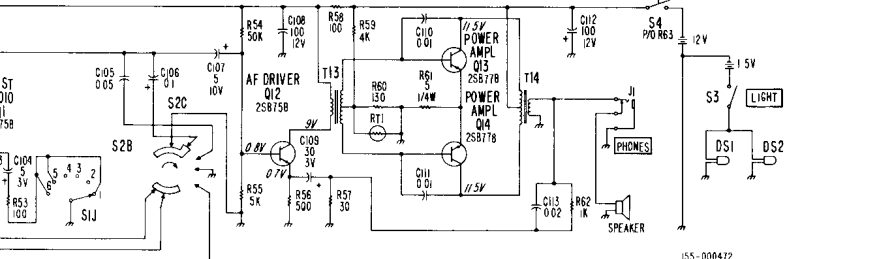

155-000472

PRINTED CIRCUIT BOARD-C

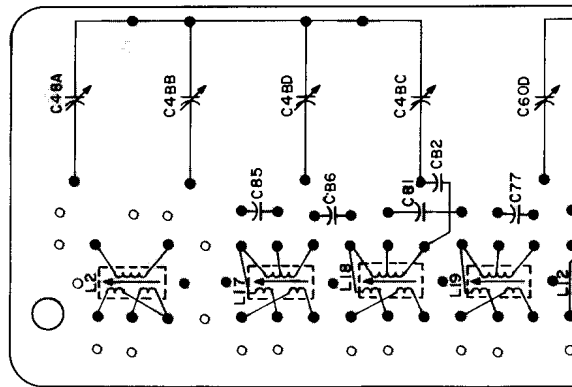

PRINTED CIRCUIT BOARD-B

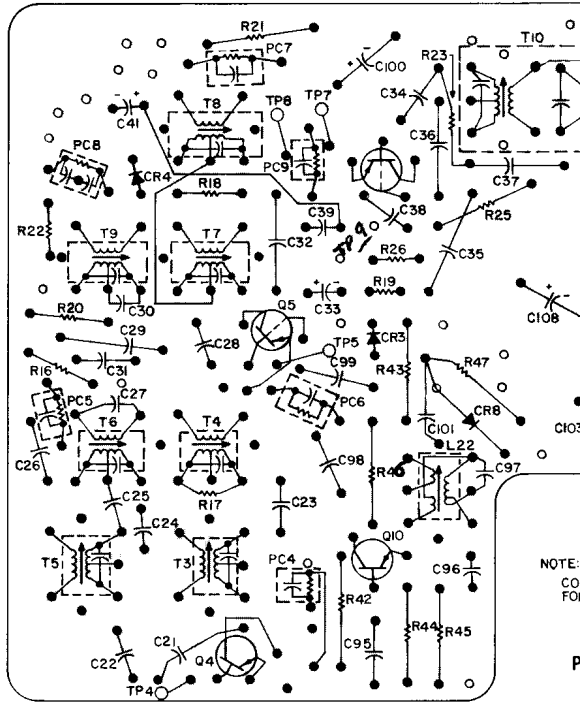
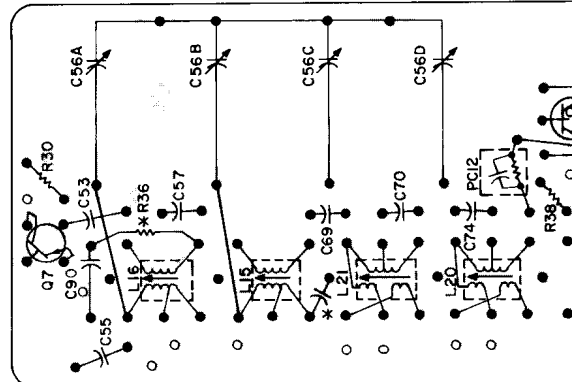

NOTE:
 CO
 FO
 P

*C3

NOTE:
WIRING IS SHOWN FROM
FOIL SIDE OF BOARD.
* INDICATES COMPONENT MOUNTED
ON FOIL SIDE OF BOARD.

156-006965

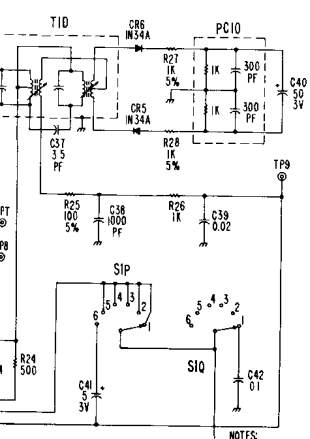

- NOTES:
- UNLESS OTHERWISE SPECIFIED:
ALL RESISTORS ARE IN OHMS, 50%, 1/8 WATT.
ALL CAPACITORS ARE IN MICROFARADS.
(SEE PARTS LIST FOR VOLTAGE RATINGS.)
 - ALL WAFERS OF BAND SELECTOR SWITCH, S1, ARE
MECHANICALLY GANGED. SWITCH POSITIONS FOR S1
ARE SHOWN BELOW.
- | BAND SELECTOR | |
|---------------|-----|
| POSITION | LN |
| 1 | BC |
| 2 | SW1 |
| 3 | SW2 |
| 4 | SW3 |
| 5 | FM |
| 6 | |
- ALL WAFERS OF TONE SWITCH, S2, ARE MECHANICALLY
GANGED. S2 SHOWN IN LOW TONE POSITION (EXTREME
LOW).
 - ALL VOLTAGES ARE NEGATIVE VALUES MEASURED
WITH RESPECT TO GROUND.

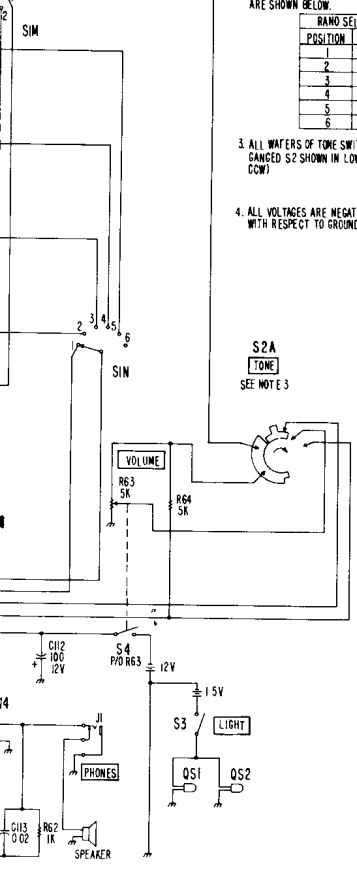

155-000472

PRINTED CIRCUIT BOARD-C

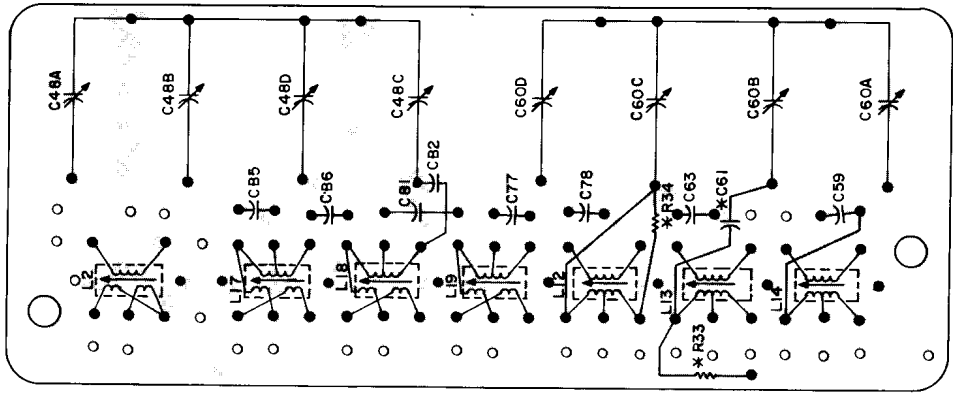

NOTE:
WIRING IS SHOWN FROM FOIL
SIDE OF BOARD.
* INDICATES COMPONENT MOUNTED
ON FOIL SIDE OF BOARD.

156-006967

PRINTED CIRCUIT BOARD-B

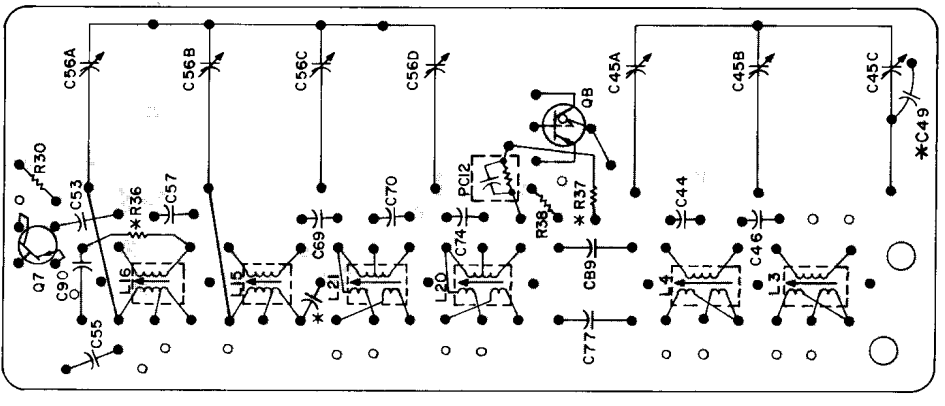

NOTE:
WIRING IS SHOWN FROM FOIL
SIDE OF BOARD.
* INDICATES COMPONENT MOUNTED
ON FOIL SIDE OF BOARD.

156-006966

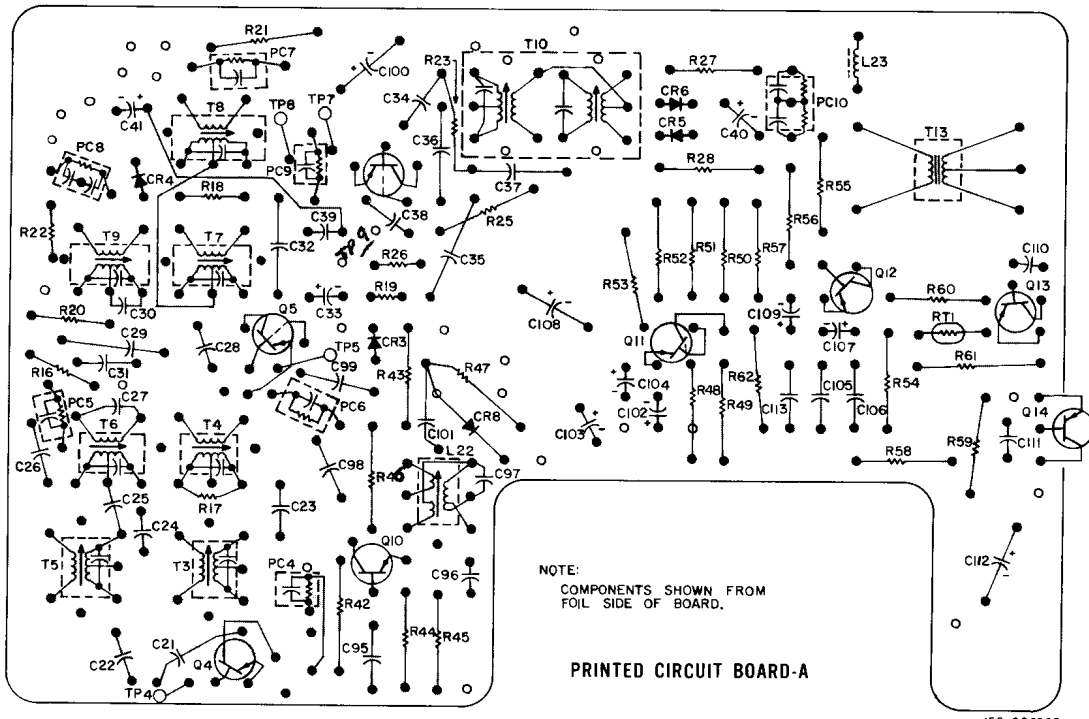

NOTE:
COMPONENTS SHOWN FROM
FOIL SIDE OF BOARD.

PRINTED CIRCUIT BOARD-A

156-006968

ALIGNMENT PROCEDURE

- Should it become necessary at any time to check the alignment of this receiver, proceed as follows
- 1) Connect an audio output power meter to a phone jack. Plug the phone jack into the PHONES receptacle.
 - 2) Set VOLUME control for maximum.
 - 3) Use the lowest setting of signal generator capable of producing 4.50 MW indication on the output meter.
 - 4) Use a non-metallic alignment tool.
 - 5) Repeat adjustments to insure good results.

AM ALIGNMENT CHART

AM Alignment Signal Generator			Receiver		Adjust	
Step	Band	Connection to Receiver	Input Signal Frequency	Dial Setting	Remarks	
1	BC	Connect signal generator through a 0.05 μ F capacitor to TP3. Ground lead to the receiver chassis.	Exactly 455 KC. (400 CPS, 30% AM modulated.)	Tuning gang fully open. (Minimum capacity).	Adjust for maximum output on output meter.	T9, 5, 6, 11, 12.
2	BC	Use radiating loop. Loop of several turns of wire, or place generator lead close to receiver for adequate signal pickup. Connect generator output to one end of this wire.	Exactly 600 KC. (400 CPS, 30% AM modulated.)	600 KC	Same as step 1.	BC Oscillator core L18.
3	BC	Same as step 2.	Exactly 1400 KC. (400 CPS, 30% AM modulated.)	1400 KC	Same as step 1.	BC Oscillator trimmer C48C.
4	BC	Same as step 2.	Exactly 600 KC. (400 CPS, 30% AM modulated.)	600 KC	See NOTE A	BC Antenna coil L1.
5	BC	Same as step 2.	Exactly 600 KC. (400 CPS, 30% AM modulated.)	600 KC	Same as step 4.	BC RF core L13.
6	BC	Same as step 2.	Exactly 1400 KC. (400 CPS, 30% AM modulated.)	1400 KC	Same as step 1.	BC Antenna trimmer C45C.
7	BC	Same as step 2.	Exactly 1400 KC. (400 CPS, 30% AM modulated.)	1400 KC	Same as step 1.	BC RF trimmer C50B.
8	BC	Repeat steps 2, 3, 4, 5, 6 and 7 until no further improvement is obtained.				
9	LW	Same as step 2.	Exactly 200 KC. (400 CPS, 30% AM modulated.)	200 KC	Same as step 1.	LW Oscillator core L17.
10	LW	Same as step 2.	Exactly 370 KC. (400 CPS, 30% AM modulated.)	370 KC	Same as step 1.	LW Oscillator trimmer C48D.
11	LW	Same as step 2.	Exactly 200 KC. (400 CPS, 30% AM modulated.)	200 KC.	Same as step 4.	LW Antenna coil L1.

AM ALIGNMENT CHART

AM Alignment Signal Generator			Receiver		Adjust	
Step	Band	Connection to Receiver	Input Signal Frequency	Dial Setting	Remarks	
12	LW	Same as step 2.	Exactly 200 KC. (400 CPS, 30% AM modulated.)	200 KC	Same as step 1.	LW RF core L12.
13	LW	Same as step 2.	Exactly 370 KC. (400 CPS, 30% AM modulated.)	370 KC	Same as step 1.	LW Antenna trimmer C48B.
14	LW	Same as step 2.	Exactly 380 KC. (400 CPS, 30% AM modulated.)	370 KC	Same as step 1.	LW RF trimmer C60C.
15	LW	Repeat steps 9, 10, 11, 12, 13 and 14 until no further improvement is obtained.				
16	SW1	Connect signal generator through a 30 pF in series with 47 ohm resistor to the external antenna coil lug. Ground lead to the receiver chassis.	Exactly 2.2 MC. (400 CPS, 30% AM modulated.)	2.2 MC	Same as step 1.	SW1 Oscillator core L19.
17	SW1	Same as step 16.	Exactly 3.8 MC. (400 CPS, 30% AM modulated.)	3.8 MC.	Same as step 1.	SW1 Oscillator trimmer C60D.
18	SW1	Same as step 16.	Exactly 2.2 MC. (400 CPS, 30% AM modulated.)	2.2 MC.	Same as step 1.	SW1 Antenna core L2.
19	SW1	Same as step 16.	Exactly 2.2 MC. (400 CPS, 30% AM modulated.)	2.2 MC.	Same as step 1.	SW1 RF core L14.
20	SW1	Same as step 16.	Exactly 3.8 MC. (400 CPS, 30% AM modulated.)	3.8 MC	Same as step 1.	SW1 Antenna trimmer C48A.
21	SW1	Same as step 16.	Exactly 3.8 MC. (400 CPS, 30% AM modulated.)	3.8 MC.	Same as step 1.	SW1 RF trimmer C60A.
22	SW1	Repeat steps 16, 17, 18, 19, 20 and 21 until no further improvement is obtained.				
23	SW2	Same as step 16.	Exactly 6.4 MC. (400 CPS, 30% AM modulated.)	6.4 MC	Same as step 1.	SW2 Oscillator core L20.
24	SW2	Same as step 16.	Exactly 9.4 MC. (400 CPS, 30% AM modulated.)	9.4 MC.	Same as step 1.	SW2 Oscillator trimmer C56D.
25	SW2	Same as step 16.	Exactly 6.4 MC. (400 CPS, 30% AM modulated.)	6.4 MC.	Same as step 1.	SW2 Antenna core L3.
26	SW2	Same as step 16.	Exactly 6.4 MC. (400 CPS, 30% AM modulated.)	6.4 MC.	Same as step 1.	SW2 RF core L15.
27	SW2	Same as step 16.	Exactly 9.4 MC. (400 CPS, 30% AM modulated.)	9.4 MC	Same as step 1.	SW2 Antenna trimmer C45B.
28	SW2	Same as step 16.	Exactly 9.4 MC. (400 CPS, 30% AM modulated.)	9.4 MC	Same as step 1.	SW2 RF trimmer C56B
29	SW2	Repeat steps 23, 24, 25, 26, 27 and 28 until no further improvement is obtained.				

AM ALIGNMENT CHART

AM Alignment Signal Generator			Receiver		
Step	Band	Connection to Receiver	Dial Setting	Remarks	Adjust
30	SW3	Same as step 16.	12 MC.	Same as step 1.	SW3 Oscillator core L21.
31	SW3	Same as step 16.	17 MC.	Same as step 1.	SW3 Oscillator trimmer C56C.
32	SW3	Same as step 16.	12 MC.	Same as step 1.	SW3 Antenna Core L4.
33	SW3	Same as step 16.	12 MC.	Same as step 1.	SW3 RF core L16.
34	SW3	Same as step 16.	17 MC.	Same as step 1.	SW3 Antenna trimmer C45A.
35	SW3	Same as step 16.	17 MC.	Same as step 1.	SW3 RF trimmer C56A.
36	SW3	Repeat steps 30, 31, 32, 33, 34 and 35 until no further improvement is obtained.	600 KC.	Adjust for zero-beat output on output meter.	B.F.O. core L22.
37	BFO	Connect signal generator through a 0.05 μ F capacitor to mixer base, (TP3) Q9. Ground lead to the receiver chassis.			

NOTES:

- Check alignment of receiver antenna coil by bringing a piece of powdered iron (such as a coil slug) near the antenna loop stick, then a piece of brass. If powdered iron increases output, loop requires inductance. Change loop inductance by sliding the bobbin toward the center of ferrite core to increase inductance, or away to decrease inductance.
- Connect VTVM (0.1 volt range D.C. scale) across VOLUME control of receiver. Adjust discriminator section core (orange) for 0 volts on VTVM. Change signal generator frequency to 10.8 MC and then to 10.6 MC. Adjust discriminator primary core (green) for balanced peaks. Peak separation should be approximately 200 KC.

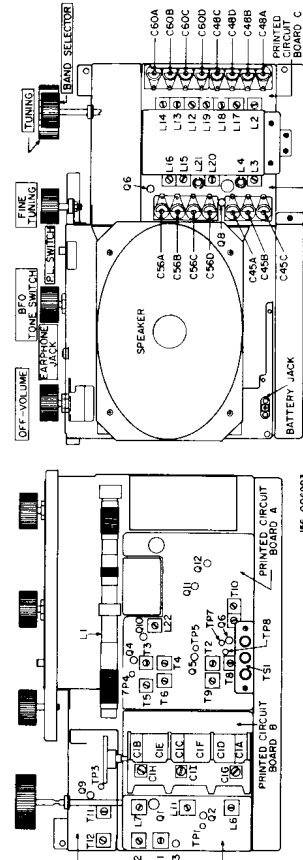

Figure 6. Top View.

FM ALIGNMENT CHART

FM Alignment Signal Generator			Receiver		Adjust	
Step	Band	Connection to Receiver	Dial Setting	Remarks		
1	FM	Connect signal generator through a 0.05 μ F capacitor to Q5 base, TP5. Ground lead to the receiver chassis.	Exactly 10.7 MC. (400 CPS, 30% AM modulated.)	Tuning gang fully closed. (Maximum capacity)	Connect VTVM between TP7 and TP8 (Ground).	Detune T10. Tune T8 and T7 for maximum indication.
2	FM	Connect signal generator through a 0.05 μ F capacitor to Q4 base, TP4. Ground lead to the receiver chassis.	Exactly 10.7 MC. (400 CPS, 30% AM modulated.)	Same as step 1.	Same as step 1.	Tune T3 and T4 for maximum indication.
3	FM	Connect signal generator through a 10PF to mixer emitter, TP1. Ground lead to the receiver chassis.	Same as step 1.	Same as step 1.	Same as step 1.	Tune T1 and T2 for maximum indication.
4	FM	Same as step 3.	Exactly 10.7 MC. (Unmodulated.)	Same as step 1.	Connect VTVM between TP9 and chassis ground.	Tune T10 for null point (0 volts.) (See NOTE B.)
5	FM	Connect signal generator through a 75 ohm resistor, including output impedance of signal generator, to the external antenna coil lug. Ground lead to the receiver chassis.	Exactly 88 MC. (400 CPS, 30% FM modulated.)	88 MC.	Adjust for maximum output on output meter.	FM Oscillator core L11.
6	FM	Same as step 5.	Exactly 105 MC. (400 CPS, 30% FM modulated.)	105 MC.	Same as step 5.	FM Oscillator trimmer C11.
7	FM	Same as step 5.	Exactly 88 MC. (400 CPS, 30% FM modulated.)	88 MC.	Same as step 5.	FM Antenna core L6.
8	FM	Same as step 5.	Same as step 7.	Same as step 7.	Same as step 5.	FM RF core L7.
9	FM	Same as step 5.	Exactly 105 MC. (400 CPS, 30% FM modulated.)	105 MC.	Same as step 5.	FM Antenna trimmer C1G.
10	FM	Same as step 5.	Same as step 9.	Same as step 9.	Same as step 5.	FM RF trimmer C1H.
11	FM	Repeat steps 5, 6, 7, 8, 9 and 10 until no further improvement is obtained.				

Figure 7. Bottom View.

