

PHOTOFACT* Folder
TRADE MARK

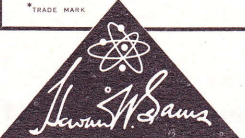

GRUNDIG MAJESTIC MODELS
TK830, TK830E, TK830U



GRUNDIG MAJESTIC MODELS
TK830, TK830E, TK830U

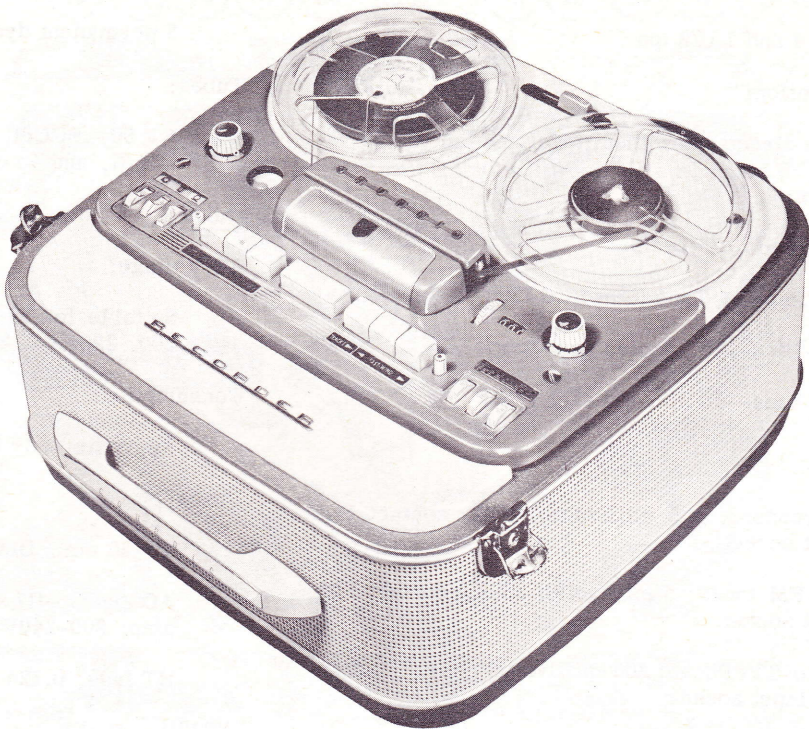

GRUNDIG MAJESTIC MODELS
TK830, TK830E, TK830U

GENERAL INFORMATION

Grundig Majestic Models TK830, TK830E, and TK830U tape recorders can record and play back on 1/4" tape. The two-track system is employed so that the full length of tape may be used twice. The recorders can record and play back in both directions.

Tape speeds are 7 1/2 and 3 3/4 ips, giving a playback time of approximately one hour for standard tape at 7 1/2 ips and two hours at 3 3/4 ips. Electromagnetic changeover from Track I to Track II takes approximately 1.5 seconds at 7 1/2 ips and less than one second at 3 3/4 ips; thus, virtually continuous track-to-track recording can be made. Three types of high-impedance input connections with push-button selection are available.

Two recording and two erasing heads are used, offset for the respective Track I and Track II positions. The Trick button (Loudspeaker/ Eraser Cut-out button), together with the Temporary Stop/Safety button and Recording button depressed, enables a second recording to be superimposed upon a previous recording.

Supplied by:
Majestic International Sales Corporation
743 West La Salle Street
Chicago 10, Illinois

This material compiled and published by
HOWARD W. SAMS & CO., INC., INDIANAPOLIS 6, INDIANA
C378

Copyright 1959 • All Rights Reserved

SPECIFICATIONS

Tape Speeds:

3 3/4 and 7 1/2 ips

Tape Direction:

Both directions without inverting tape reels

Tape Reels:

Maximum, 7" reels.

Running Time per Tape (Standard 1200-ft. tape):

7 1/2 ips--30 minutes each track

3 3/4 ips--60 minutes each track

Inputs:

Microphone; 1.5 millivolts/300K, contact 1 of input socket.

AM-FM tuner; 5 millivolts/250K, contact 1 of input socket.

Radio-TV-Phono; 100 millivolts/1meg, contact 3 of input socket.

Outputs:

External speaker; 12 ohms, contact 1 of output socket.

Amplifier; 0.6 volt/5K, contact 3 of output socket and contact 3 of input socket.

Amplifier Output:

6 watts (double-ended push-pull output stage)

Fast Forward and Rewind Time(Standard 1200-ft. tape):

7 1/2 ips--130 seconds

Automatic Stop Switch:

Electromagnetic

Tape Run System:

Recording and playback in both directions, operated by track buttons.

Frequency Range:

At 7 1/2 ips--50 to approximately 15,000 cps

At 3 3/4 ips--50 to approximately 10,000 cps

Recording Level Indicator:

Magic eye

Remote Control:

Foot switch 222 for start, stop, and backspacing

Loudspeaker:

3 permanent dynamic speakers, 18 x 13 cm

Tubes:

EF 86, ECC81, ECC83, EL95, EL95, EL95, EM 71, and 4 selenium rectifiers.

TK830

AC Voltage:

Suitable for 50 cps AC only; 117 (110-127), 150, 200, 220, and 240 volts

Consumption:

Approximately 85 watts

Fuses:

5 x 20 mm, Din 41571, surge resisting.

AC fuses; 117 volt--1.25 amps; 150 volts--1.0 amp; 200-240V--.08 amps.

HT fuse; 0.125 amp.

TK830U

AC Voltages:

Suitable for 50 and 60 cps, convertible. AC only; 117 (110-127), 150, 200, 220, and 240 volts.

Consumption:

At 50 cps, approximately 90 watts.

At 60 cps, approximately 100 watts.

Fuses:

5 x 20 mm, Din 41571, surge resisting.

AC fuses; 117 volts--1.6 amps; 150 volts--1.25 amps; 200-240 volts--1.0 amp.

HT fuse; 0.125 amp.

TK830E/60 cps

AC Voltages:

Suitable for 60 cps AC only; 117 (110-127), 150, 200, 220, and 240 volts.

Consumption:

Approximately 65 watts

Fuses:

5 x 20 mm, Din 41571, surge resisting.

AC fuses; 117 volts--1.6 amps; 150 volts--1.0 amp; 200-240 volts--1.0 amp.

HT fuse; 0.125 amp.

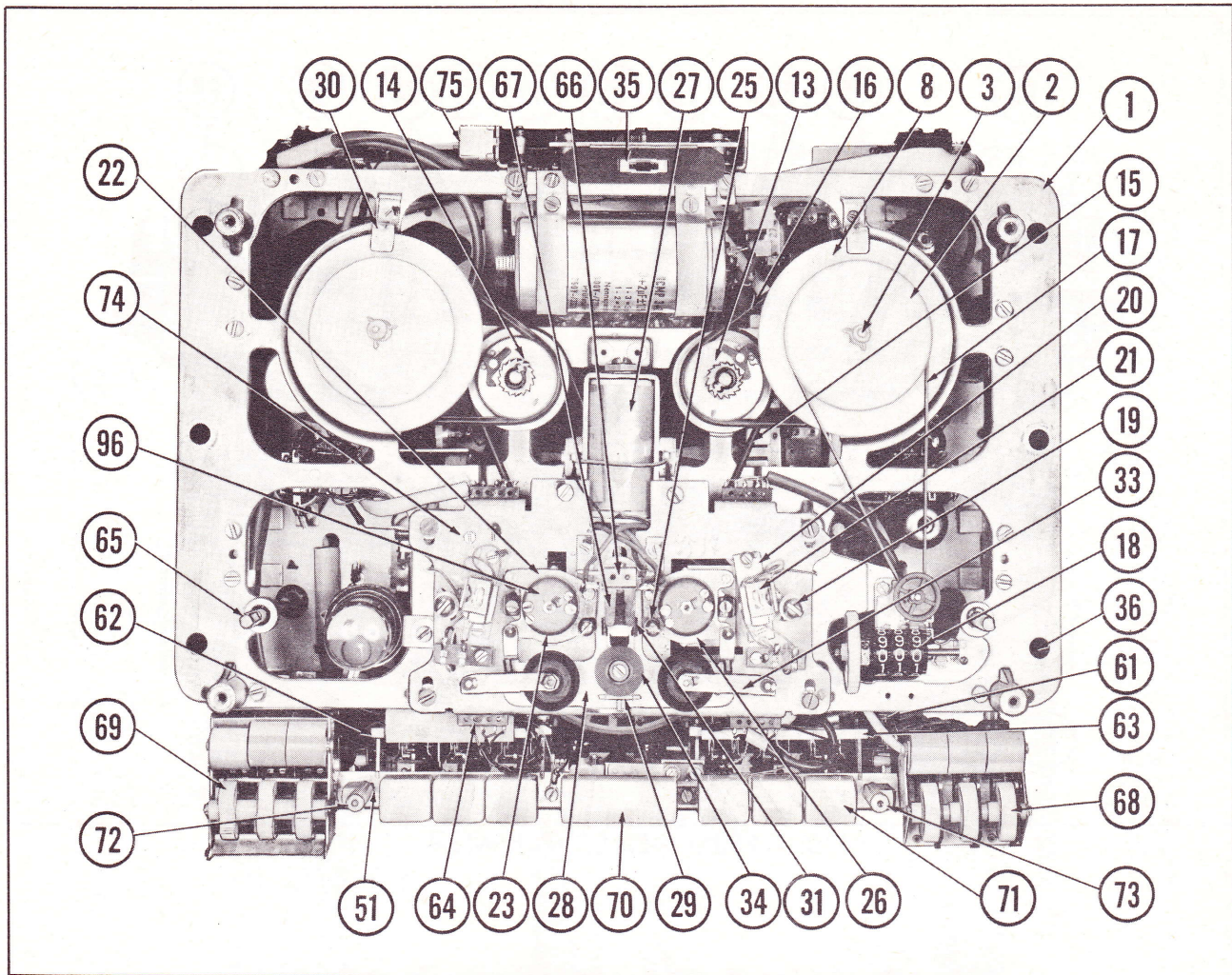

FIG. 1 TOP VIEW OF MECHANISM WITH TOP PLATE REMOVED.

GRUNDIG MAJESTIC MODELS
TK830, TK830E, TK830U

FUNCTION OF CONTROLS

Speed Switch

Set the Speed switch before the recording is started, although its position can be altered while the tape is moving. Never switch during fast rewind from fast (7 1/2 ips) to slow (3 3/4 ips) tape speed. However, switching from slow to fast speed is possible; to the right for 7 1/2 ips, to the left for 3 3/4 ips.

Recording Level Control

The Recording Level knob controls the quality of the recording.

Input Selector

The three discs on the left side of recorder are used to select any one of the three different inputs. The marking above the buttons corresponds to the appropriate sockets at the back of the recorder. Any or all of the input leads can remain connected to the input socket at the rear of the recorder at all times. To select one of the inputs, pull the notch of the disc forward. A white field indicates the on position, a red field, the off position of the particular input selection. The input selector does not function during playback.

Volume Control On-Off Switch

The Off position is marked by a red dot. During recording, this control is used for monitoring and for adjusting the volume in the built-in speakers or ear-phones. During playback, this switch controls the volume.

Tape Counter

The tape counter registers "000" to "999". The reading may be noted while recording, and reference to any given point on the tape may be rapidly made. After a recorded tape has been logged or referenced, always "zero" the indicator before playing the recorder and before the tape is threaded on the reel.

Multisonic Tone Control

The Multisonic tone control is used only when playing back through the built-in speakers or through an external speaker. The left-hand disc of the Multisonic tone control emphasizes the bass boost, the right-hand disc, the treble boost. By means of the middle disc, all notes between the two extremities of the bass and treble notes are controlled.

FOLDER 5

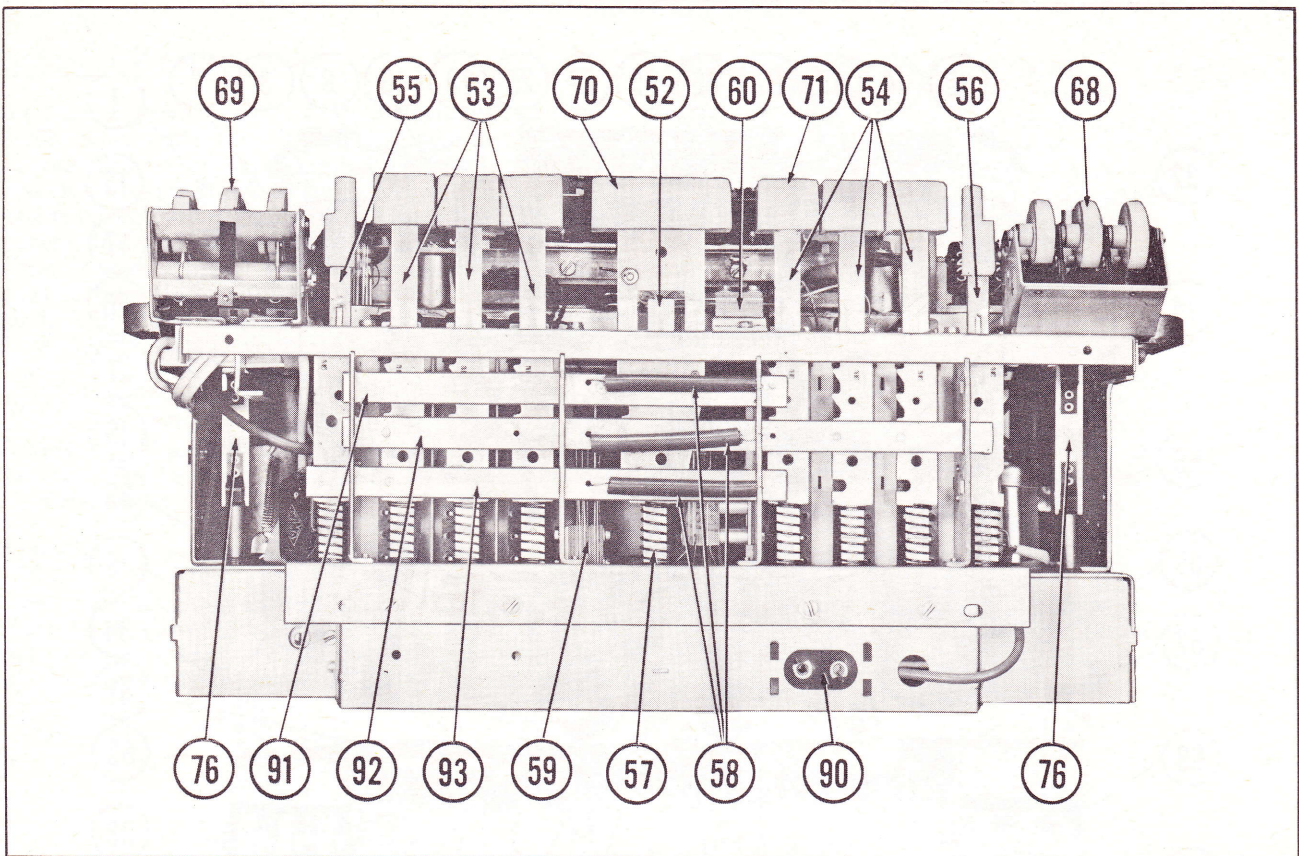

FIG. 2 FRONT VIEW OF MECHANISM

Stop Bar

The Stop bar stops the motor and returns all depressed buttons except the track buttons to neutral.

Safety Button/Temporary Stop Button

This button prevents accidental erasure. Moving the depressed Safety button slightly forward locks it. The tape will not move until this button is released. The same button also serves as a temporary stop, halting the recorder in either record or playback only as long as the button is depressed.

Trick Button-Speaker Control

The Trick button permits blending of voices, sound effects, or music into previous recordings. The same button also cuts off the speakers. Depressing the button switches off the built-in-speaker. Depressing and moving the button slightly forward will lock it.

Recording Button

The Recording button is used with the Safety button to place the recorder in the Record position.

Playback Button

The Playback button places the recorder in the Playback position.

Track II Button

The Track II button starts the recorder operating on Track II, with the tape moving from right to left. The recorder will either record or play back, according to which button has been depressed.

Track I Button

Same as Track II button, except tape moves from left to right.

Fast Wind Buttons

These two buttons are used to find the beginning of a particular recording. They start the reels turning rapidly. The entire tape can be wound from one reel to the other in approximately two minutes.

NOTE: If either Fast Wind buttons are in use, the Stop bar must be depressed before changing functions. In other words, don't go from Fast Wind to Recording or Playback without first depressing the Stop bar. When using either of these buttons, depress and release them immediately.

Voltage Selector

To set the voltage selector to another voltage, pull out voltage tapping plug (83) in voltage selector (84) and reset so that the voltage closest to the power supply voltage is visible in the tiny window of voltage tapping plug (83).

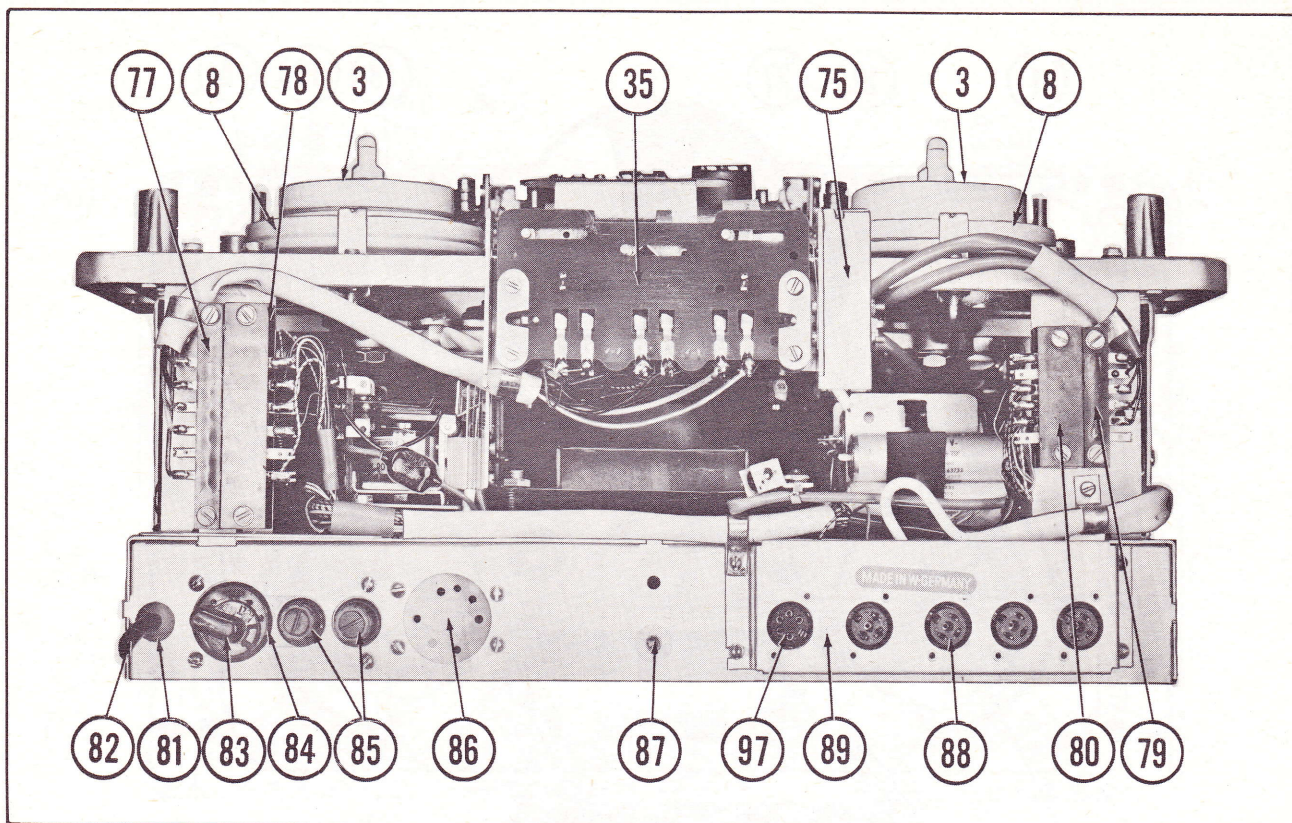

FIG. 3 REAR VIEW OF MECHANISM

OPERATING INSTRUCTIONS

Threading the Tape

1. Two reels are supplied, one full and the other empty.
2. The full reel fits on the left-hand spindle, the empty one on the right.
3. Hold full reel in left hand with loose end of tape hanging down left side of reel. Now place the reel on the left-hand spindle. Turn the reel slightly until it falls into place and is held securely by the ridges on the spindle.
4. Place empty reel on right-hand spindle.
5. Place tape into sound channel and slip the free end into slot in empty reel. Turn empty reel counterclockwise until tape is secured to reel.

NOTE: The tape has a shiny and a dull side. Always be sure the shiny side faces the buttons.

Turning Recorder On

Once the voltage selector has been adjusted to agree with rating of wall receptacle, the recorder may be plugged in. Turn Volume Control/On-Off switch to the right. After a few seconds (while the tubes warm up), the recorder is ready to record or playback.

To Record from Microphone

1. Depress Track I button.

2. Depress the small Safety button on the left of the Recording button and then depress the Recording button. Keep Safety button depressed (or locked). Set Volume control to low level.
3. Talk into microphone, holding it about 18 inches from the mouth. The Magic Eye will start to flutter. Adjust Record Level control until Magic Eye just closes on the loud parts of speech. If the Volume control is too high, the recording will be distorted.
4. Release Safety button. Tape will move from left-hand to right-hand reel, and any sound entering the microphone will be recorded on tape.

NOTE: To switch to the second track, depress Track II button. The tape will move in the opposite direction, and the recording can be continued on other half of tape.

To Record from AM-FM Radio

1. Connect lead 237 to tape recorder socket of radio and to input socket of tape recorder marked AM-FM Tuner.
2. Operate middle input selector wheel.
3. Depress and lock Safety button. Depress Record button and tune accurately to broadcasting station.

GRUNDIG MAJESTIC MODELS
TK830, TK830E, TK830U

FOLDER 5

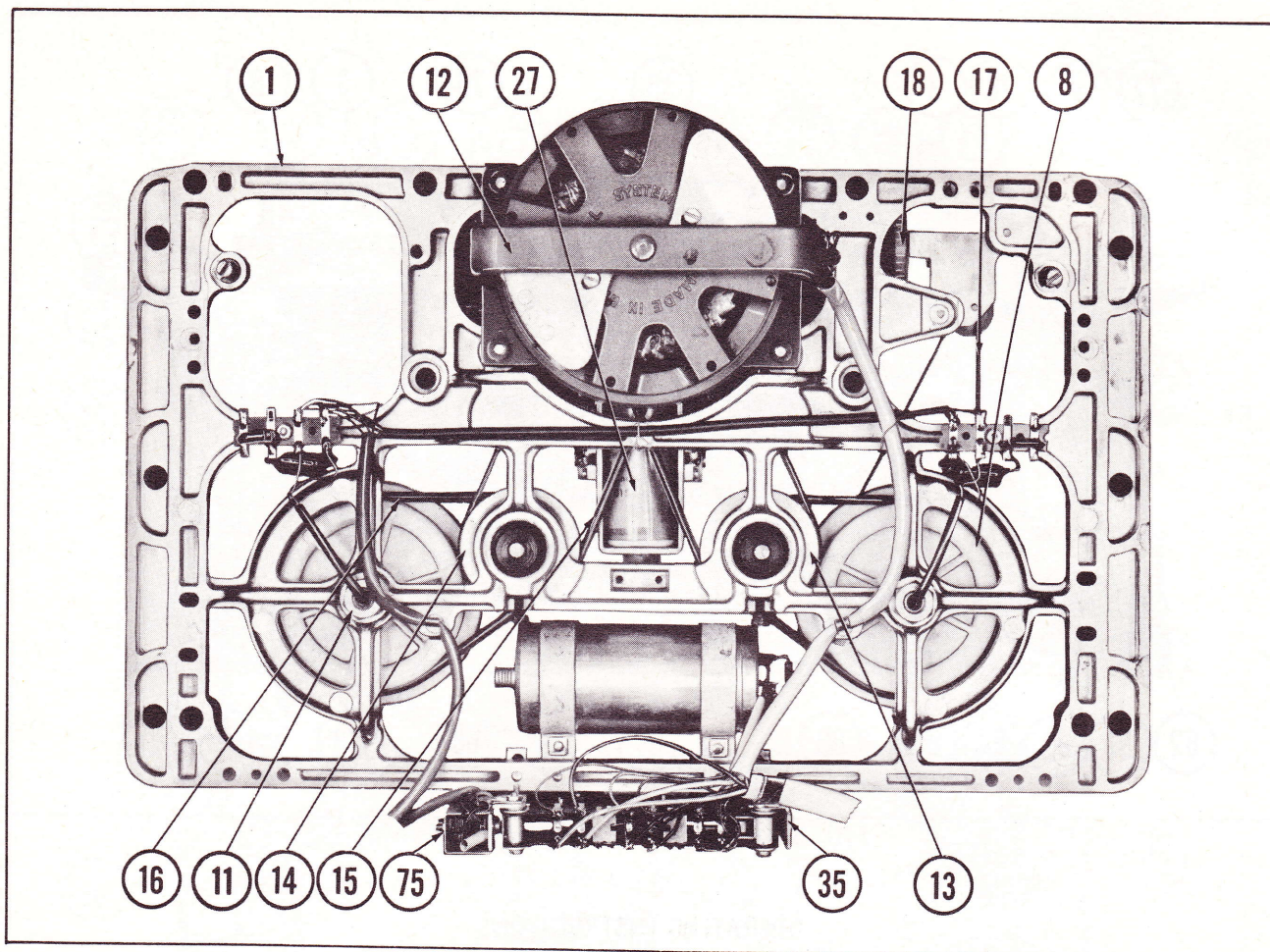

FIG. 4 BOTTOM VIEW OF MECHANISM

4. Turn Recording Level control clockwise until the two sections of green light of the Magic Eye just begin to meet at the loudest passages.
5. Release Safety button.
6. At end of recording, depress Stop bar and mark the reading of the tape counter.

NOTE: Lead 237 has 3-way plugs on both ends; therefore, the radio must have a corresponding socket for proper connection. See "Installing Socket for Connecting Tape Recorder to Radio."

To Record from Phonograph

1. Connect the leads from the pickup arm of record player to the red and black banana plugs of connection lead 233.
2. Connect the 3-prong plug to socket marked Radio-TV-Phono or recorder.
3. Fasten the ground of the pickup to the sleeve of the plug.
4. Operate outside input selector wheel.
5. Start the record player.
6. Place recorder in Record position.

To Record a Telephone Conversation

The Grundig Telephone Adaptor 243T is a small coil hidden in a plastic case. This coil picks up the magnetic field from the coils which form part of all telephones. With the coil, both incoming and outgoing conversations can be recorded.

The plug of the adaptor fits into the socket marked AM-FM Tuner. Slightly moisten the rubber disc on the bottom of the Adaptor to improve its sticking power, and press onto the telephone.

Different types of telephones require a different position of the Adaptor. Here is how to find the best position for each type:

1. Plug the Adaptor into the socket marked AM-FM Tuner at rear of recorder, and switch on recorder.
2. Proceed as for recording, with the AM-FM Tuner disc (middle selector) selected. Turn Recording Level control to a convenient level. Lift the telephone receiver so that the dial tone can be heard. Move the Adaptor slowly around the base of the telephone, with the rubber disc just touching the telephone. The Magic Eye will oscillate, and the dial tone will be heard through the speaker. Do not forget to adjust the monitor control. When the Magic Eye

registers its maximum deflection and the dial tone is loudest, the best position has been reached. Fasten the Adaptor to the telephone at this point.

NOTE: The Adaptor is sensitive to all kinds of magnetic fields and should be used at least four and one-half feet from the recorder.

IMPORTANT: It is against the law to record a telephone conversation, except under certain conditions. See your local authorities about these conditions before recording a conversation. Never record a conversation without the caller's permission under any circumstances.

To Play Recordings

1. Thread tape as described under "Threading Tape."
2. Set the two-speed selector knob to the speed at which the recording was made.
3. Depress the Playback button.
4. Adjust the Volume control and turn the wheels of the Multisonic tone control for desired tone level.

Automatic Stop

Metal foils at both ends of the tape automatically switch off the motor. The motor is switched off at the end of each track whether the recorder is recording, playing back, or fast winding. To start tape again after the motor has been switched off by the metal foils, depress the track button (which is already depressed) further.

High-Speed Fast Wind

To play a certain portion of tape again, the entire reel need not be rewound. Depress the correct button, depending on which direction the tape must be transported. The Fast Wind (right to left) button is next to the Track I button, and the Fast Wind (left to right) button is next to the Trick Button-Speaker control.

To Edit and Splice Tape

NOTE: Since one track cannot be edited and spliced without affecting the other track, recordings to be edited should be limited to one track only.

1. The tape may be edited by cutting out unwanted portions or by joining selections into another sequence. Announcements, etc., may be inserted between selections. Unused sections of tape can be spliced for re-use.
2. For best results, cut tape at a slight diagonal, join ends with splicing tape on the glossy side, and trim any excess width.

Installing Socket for Connecting Tape Recorder to Radio

For high-quality recording from a radio, a worthwhile improvement may be obtained by feeding the recorder directly from the detector diode. This makes the level of a recording independent from the

setting of the radio volume control and bypasses the distortion of the output stage. The diode connection consists basically of a potential divider, which should be mounted as close as possible to the radio volume control. If DC is present on the volume control, a blocking capacitor should be added in series. The value of 1-2 megohms is based on a radio delivering approximately 100 millivolts to the diode load. Where the voltage varies considerably from this figure, the value in megohms may be calculated by multiplying the voltage in volts by 17 (i. e., 200 millivolts requires 3.4 megohms).

Fig. 5 shows the measurements for the cutout in the rear of the chassis.

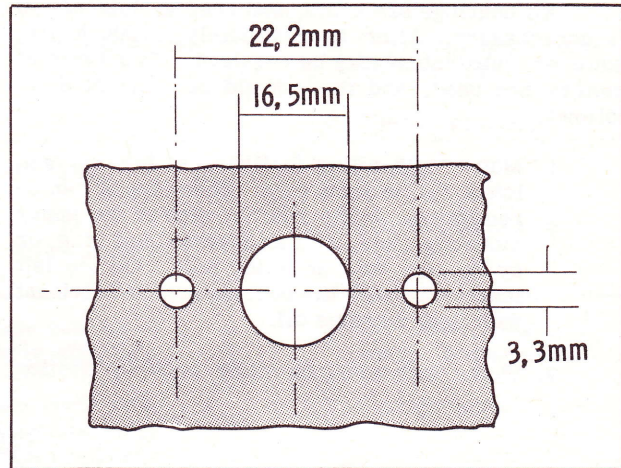

FIG. 5 REAR CHASSIS CUTOUT

Fig. 6 shows the wiring. Both resistors are connected to contact 1 (recording) of socket. Contact 2 is lead-to-ground connection of Volume control. For playback, contact 3 (playback) will be connected to phone socket. For this connection, use shield wire only if distance between connection points is large. Generally, the socket is ground by fastening it to the chassis, but the top of the socket housing can also be soldered to the chassis. Connection lead 237, equipped with 3-way plugs at both ends, is used to connect the tape recorder to the radio. The part number of the 3-way socket is No. 5784 (Din 41524).

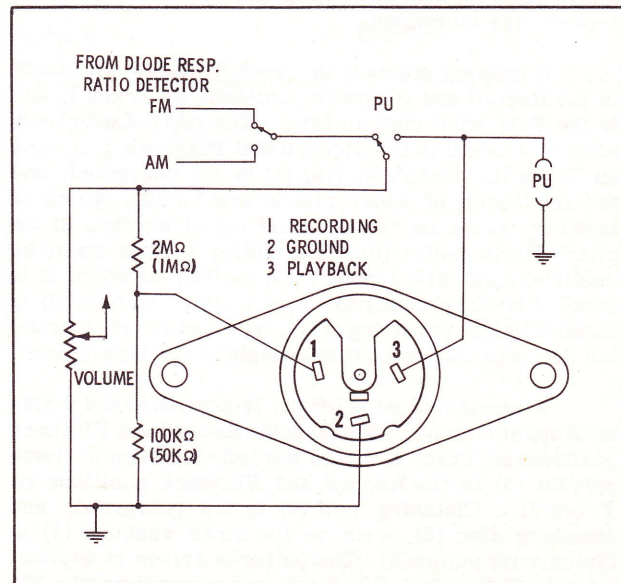

FIG. 6 TAPE RECORDER-TO-RADIO SOCKET

GRUNDIG MAJESTIC MODELS
TK830, TK830E, TK830U

FOLDER 5

DISASSEMBLY INSTRUCTIONS

1. Remove the two control knobs and the two-speed knob.
2. Unscrew the four coil-slotted brass screws.
3. Lift off top deck (38) and unscrew the six small nuts securing the chassis to the cabinet.
4. Lift the chassis partly out of the cabinet.

5. Unplug the loudspeaker leads.

Now lift the chassis completely out of the cabinet. Never lift the chassis by the clutches because serious damage will result. When the chassis is clear of the cabinet, all tubes will be readily accessible. By removing the bottom screen, all components can be easily reached.

LUBRICATION

All bearings are oilite, and regular lubrication is unnecessary. After approximately 1,000 hours, however, lubrication may be required. Two types of motors are used, and they should be lubricated as follows:

1. Motor with oiling facilities in friction and lower ball bearing only--These types can be recognized by the shallow dish in the upper mounting plate, with an inserted felt ring, or by the cap, with an oiling hole. Oil the felt inserts and fill the containers for lubricant with light machine oil.
2. Motor with oiling facilities in lower friction

bearing and ball bearing for spindle, and facilities for greasing upper friction bearing through a grease container--These types can be recognized by the shallow dish in the upper mounting plate, with cover and without felt insert. Lubricate the lower bearing as in step 1, and fill the grease container in the upper mounting plate with Sta-Put grease.

Clean all other self-lubricating bearings by wiping off dust, grease, and all other foreign matter. Then lubricate the bearings with machine oil. Avoid excessive oiling, because surplus oil will be thrown onto drive belts, clutches, pressure roller, or friction wheels.

CLEANING

Pressure Roller and Drive Capstan

Dirt or other foreign matter on the pressure roller or capstan will increase wow and may cause tape to jump from its guides. Remove any tape residue,

dust, and dirt from the roller by holding a piece of fine sandpaper against the roller while it is rotating. Crocus paper is recommended for cleaning the drive capstan; its surface should always look highly polished.

ADJUSTMENTS

Electromagnetic Clutches

Clutch components or the complete clutch assembly may be easily adjusted or replaced. However, faults must be correctly diagnosed before any clutch repairs are attempted.

A braking action is obtained from the left clutch in the Record and Playback positions on Track I, and in the Fast Wind right to left. The right-hand clutch acts as a brake in the Record and Playback positions on Track II. Clutching coil (4) is not energized, and the felt insert of upper clutch spindle (3), which is braking, rests on the polished top of surface of its clutch drive pulley (8). The pulley is kept static by unidirectional drive pulley (13) or (14), to which it is coupled by drive belt (16). Upper clutch spindle (3) is rotated by the unreeling of the tape and exerts a braking action proportional to the weight of the tape or reel.

A small amount of torque is applied to the right-hand upper clutch spindle (3) in the Record and Playback positions on Track I, and to the left-hand upper clutch spindle (3) in the Record and Playback positions on Track II. Clutching coil (4) is not energized, and clutching disc (6) rests on its three washers (7) in clutch drive pulley (8). The pulley is driven at approximately 650 rpm at 7 1/2 ips and approximately 325 rpm at 3 3/4 ips, and a slipping clutch action occurs

between the felt inserts of upper clutch spindle (3) and the top of clutch drive pulley (8). This action is directly proportional to the amount of tape on the reel; i. e., the torque increases at the weight of the tape increases. The tape pull should be reasonably uniform over the entire tape. In both Fast Wind positions, clutching coil (4) of the take-up clutch is energized. This lifts clutching disc (6) and locks it to the plastic insert of upper clutch spindle (3). The tape will then be rapidly wound onto the reel.

Replacing Clutch

To remove complete clutch (2), first disassemble unit and remove from cabinet (see "Disassembly Instructions").

1. Unsolder the two leads to clutching coil (4) and remove upper clutch spindle (3).
2. Remove bottom locking nuts (11) and lift out clutch.
3. Insert new assembly and half-tighten the bottom nut.
4. Insert two 0.2-mm steel washers between clutching coil (4) and upper clutch spindle (3). Rotate upper clutch spindle (3) and observe

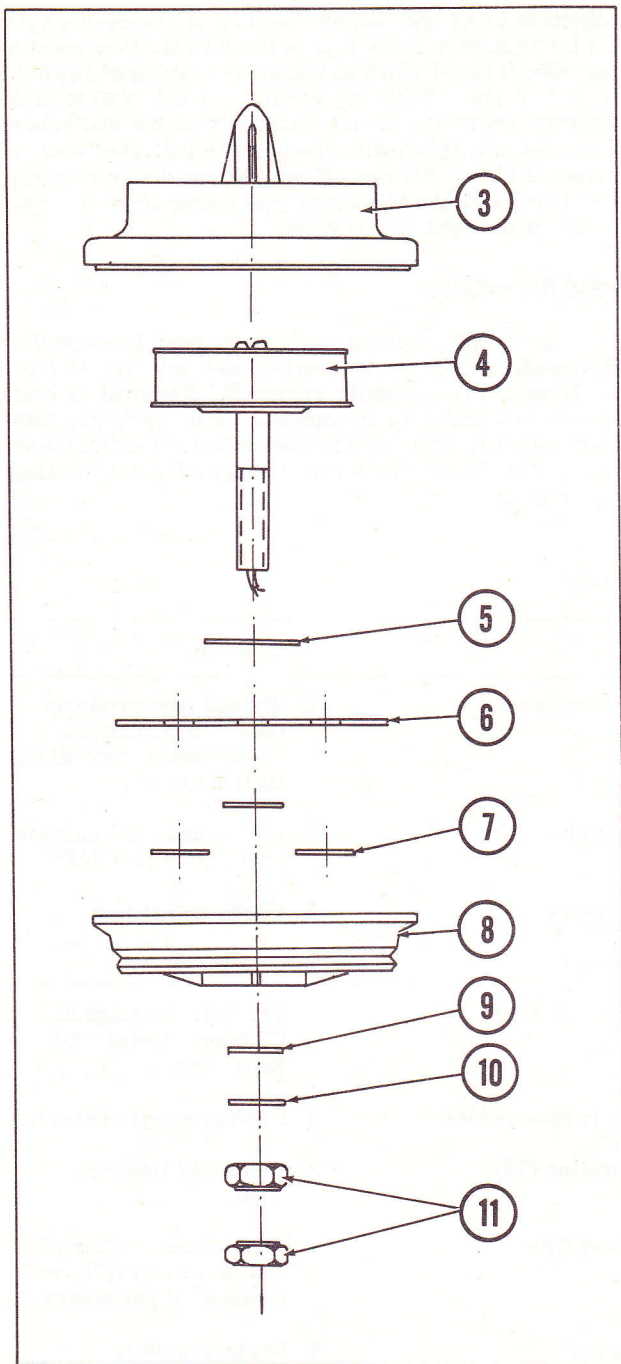

FIG. 7 EXPLODED VIEW OF CLUTCH ASSEMBLY

whether its felt insert just clears the top of clutch drive pulley (8). If it does, remove the top steel washer (leaving one washer on the shaft) and again rotate upper clutch spindle (3). The felt insert should now touch the top half of clutch drive pulley (8), causing a smooth friction.

5. To adjust for correct alignment, hold bottom hexagon nut and turn the shaft (with a screwdriver) clockwise to reduce the spacing and counterclockwise to increase the spacing between the clutch parts.
6. Make sure both clutch spindles are even with each other by holding a steel straightedge

across their tops. Then tighten the lower hexagon nut and recheck as follows: Insert a 0.2-mm washer and check for sufficient friction between clutch drive pulley (8) and upper clutch spindle (3). Next insert a second steel washer. Upper clutch spindle (3) should just clear clutch drive pulley (8). Now remove both washers, replace upper clutch spindle (3) and the upper clutch spindle securing bracket (30), and resolder the two clutch coil leads.

Unidirectional Drive Pulleys

The maximum play of unidirectional pulleys (13) and (14) should not exceed 50°. The pulleys must not be subjected to any pressure. If the fault occurs in any part of a unidirectional drive pulley, replace the complete item.

Centrifugal Switch

When centrifugal switch (66) is in neutral, the middle contact is raised by the operating pin. The upper contacts should be deflected in this position by 0.3 mm or 1/64".

Recording/ Playback Head

The bias current to each recording/playback head when recording is approximately 1 milliamp and may be measured by inserting a 200-ohm resistor in series with the chassis return lead of the head. The potential drop across this resistor should be 200 millivolts + 10%. If the current differs considerably from this figure, adjust C18 for Track II and C16 for Track I. The erase voltage to each head, measured with a VTVM, should be 125-150 volts.

With 5 millivolts at 1 kc fed into the diode socket and with the Recording Level control at maximum, a head current of 16 millivolts across a resistor of 200 ohms in the chassis return lead of the head should be obtained. Remove the EL95 oscillator tube for this test.

The positioning of the head assemblies is very critical and is particularly important for perfect reproduction of recordings made from a different recorder. Make the adjustment with a test tape or with a tape on which a frequency of 6 kc has been recorded. The recording/playback heads are plugged into the baseplate and attached to the chassis by two screws. By altering the settings of these two screws, the head may be correctly aligned. Check this alignment by connecting a VTVM into the high-impedance output socket and playing back the test tape. Then adjust the recorder until the VTVM shows maximum deflection. The heads can also be aligned horizontally so that the head gap just contacts the tape. When the tape crepe rubber pressure rollers (33) are moved away, the output should not vary by more than 2 db. When the tape is running in Track I, the top edge of the left-hand recording/playback head should be 0.1 mm above the top edge of the tape, and in Track II, the bottom edge of the right-hand recording/playback head should be about 0.1 mm below the bottom edge of the tape. The pole pieces of the corresponding erase heads should be level with the (top or bottom) edge of the tape. When the recorder is running, the tape should be guided within the guide posts in an absolutely straight line.

Hum Level

Adjust humdinger R5 for minimum hum level with the recorder switched to the straight amplifier position (depress both track buttons). Then adjust humbucking coil L3, under playback conditions on both tracks, for minimum hum. The level should not exceed 1/200th of 1 kc with a recording made at full modulation level on both tracks and at both speeds. This corresponds to a hum content of -46 db, and a compromise setting must be found so that the hum at either speed or track does not exceed this level.

Absorption Coil

Remove oscillator EL95 and switch to Record. Connect a signal generator, set at 15 kc, to the diode input. Connect a VTVM to the high-impedance output socket and adjust the signal generator output for a convenient reading on the VTVM. With the two-speed

switch at 7 1/2 ips, adjust the core of absorption coil L2 for maximum deflection on the VTVM. Now reduce the audio frequency to 9 kc and set the two-speed switch to 3 3/4 ips. Note the reading on the VTVM and slightly sweep the signal frequency above and below 9 kc, observing whether the peak is indicated with a signal of 9 kc \pm 300 cps. If not, repeat the procedure, this time with the frequency just above 15 kc and fed to the diode input at 7 1/2 ips.

Head Assemblies

After the recorder has been used for a while, the heads should be inspected, and any dirt or iron oxide should be carefully removed. Removal is best done with a match or orange stick and, perhaps, with methylated spirits. Never use carbon tetrachloride or any acetone fluid; these will damage the plastic casing of the heads.

TROUBLE CHART

Symptom	Cause	Remedy
Tape does not move in Record or Playback, but motor runs.	1. Tape not threaded properly.	1. Thread tape properly (see "Threading the Tape" under "Operating Instructions").
	2. Pressure slider (28) jamming.	2. Adjust and/or lubricate pressure slider (28).
	3. Faulty pressure solenoid (27) or related circuit.	3. Check and repair.
Recorder does not run at correct speed when recording or playing back.	1. Too much friction on supply reel.	1. See "Electromagnetic Clutches" under "Adjustments."
	2. Tape jams in tape guides.	2. Realign sound channel.
	3. Pressure roller (34) jamming.	3. Clean and lubricate shaft.
	4. Tape counter (18) jamming.	4. Check tape counter (18) and drive belt (17), and replace, if necessary.
	5. Faulty motor.	5. Replace motor.
	6. Tape not threaded properly.	6. Thread tape properly (see "Threading the Tape" under "Operating Instructions").
Tape runs sluggishly when starting.	1. Faulty centrifugal switch (66).	1. Check push rod in motor spindle; clean and lubricate, if necessary.
	2. Spring set assembly (67) of centrifugal switch (66) not closing in running position.	2. Adjust.
Tape runs slowly in either Fast Wind position.	1. Faulty centrifugal switch (66).	1. Check push rod in motor spindle; clean and lubricate, if necessary.

TROUBLE CHART (CON'T.)

Symptom	Cause	Remedy
	2. Spring set assembly (67) of centrifugal switch (66) closing in running position.	2. Adjust.
No fast wind.	1. Clutches improperly adjusted. 2. Clutching coil (4) defective. 3. Clutching coil (4) not being energized.	1. See "Electromagnetic Clutches" under "Adjustments." 2. Replace clutching coil (4). 3. Check circuit.
Head assemblies wear too quickly.	1. Crepe rubber pressure roller (33) improperly adjusted.	1. Adjust crepe rubber pressure roller (33).
Tape jumps from tape guides.	1. Pressure roller (34) and capstan spindle not parallel. 2. Dirt or iron oxide on pressure roller (34) or on capstan spindle. 3. Sound channel not correctly adjusted.	1. Adjust shaft of pressure roller (34), or replace. 2. Clean and polish pressure roller (34) or capstan spindle. 3. Adjust tape guides.
Tape scrapes against edge of reel.	1. Reel warped. 2. Tape guides out of alignment. 3. Clutches improperly adjusted.	1. Replace reel. 2. Realign tape guides. 3. See "Electromagnetic Clutches" under "Adjustments."
No fast wind.	1. Clutches improperly adjusted. 2. Clutching coil (4) defective. 3. Clutching coil (4) not being energized.	1. See "Electromagnetic Clutches" under "Adjustments." 2. Replace clutching coil (4). 3. Check circuit.
Head assemblies wear too quickly.	1. Crepe rubber pressure roller (33) improperly adjusted.	1. Adjust crepe rubber pressure roller (33).
Tape jumps from tape guides.	1. Pressure roller (34) and capstan spindle not parallel. 2. Dirt or iron oxide on pressure roller (34) or on capstan spindle. 3. Sound channel not correctly adjusted.	1. Adjust shaft of pressure roller (34), or replace. 2. Clean and polish pressure roller (34) or capstan spindle. 3. Adjust tape guides.
Tape scrapes against edge of reel.	1. Reel warped. 2. Tape guides out of alignment.	1. Replace reel. 2. Realign tape guides.

GRUNDIG MAJESTIC MODELS
TK830, TK830E, TK830U

FOLDER 5

TROUBLE CHART (CON'T.)

Symptom	Cause	Remedy
	3. Clutches improperly adjusted.	3. See "Electromagnetic Clutches" under "Adjustments".
Safety button jamming.	<ol style="list-style-type: none"> 1. Burr on locking bar of Safety button. 2. Tape deck not correctly aligned. 	<ol style="list-style-type: none"> 1. Clean bar. 2. Remove deck and adjust location of push-button assembly (51) (unscrew two screws in front of cast top frame).
Right-hand reel spindle sluggish when starting.	<ol style="list-style-type: none"> 1. Too much friction from tape counter (18). 2. Too much friction from reel spindle on shaft. (This also applies to left-hand reel spindle). 	<ol style="list-style-type: none"> 1. Replace tape counter(18). 2. Clean and lubricate shaft.
Distorted recording; low volume due to no recording bias.	<ol style="list-style-type: none"> 1. Faulty bias oscillator tube EL95 or oscillator coil. 2. Faulty recording head. 	<ol style="list-style-type: none"> 1. Check and replace. 2. Replace both recording heads.
No erase.	<ol style="list-style-type: none"> 1. Faulty bias oscillator. 2. Faulty erasing head (21). 	<ol style="list-style-type: none"> 1. Check and replace. 2. Replace erasing head (21).
Cross talk from other channel.	<ol style="list-style-type: none"> 1. Recording head or erase head gap not correctly adjusted; tape not guided horizontally. 	<ol style="list-style-type: none"> 1. See "Recording/ Playback Head" under "Adjustments." Adjust tape guides. Make sure that tape runs freely in all four tape guides.
Recording and erase heads cannot be adjusted to an exact vertical position.	<ol style="list-style-type: none"> 1. Dirt or foreign matter under heads. 	<ol style="list-style-type: none"> 1. Clean heads.
Wow and flutter.	<ol style="list-style-type: none"> 1. Jerky clutches. 2. Tape scratches against screening hoods of record/ playback heads. 3. Tape not guided horizontally. 4. Too much pull from take-up reel. 	<ol style="list-style-type: none"> 1. Check clutch adjustment. 2. Adjust screening hoods. 3. Check and adjust. 4. See "Electromagnetic Clutches" under "Adjustments".
Hum level too high.	<ol style="list-style-type: none"> 1. Hum-bucking coil L3 not adjusted. 2. Humdinger R5 not adjusted. 3. Heater-to-cathode short in EF86 (V1). 	<ol style="list-style-type: none"> 1. Readjust; see "Hum Level" under "Adjustments". 2. Readjust; see "Hum Level" under "Adjustments". 3. Replace EF86.

TROUBLE CHART (CON'T.)

Symptom	Cause	Remedy
	4. Faulty ECC81.	4. Replace ECC81.
	5. Faulty recording/ playback head.	5. Replace both heads.
Low gain.	1. Faulty recording bias.	1. Adjust C16, C18, R4.
	2. Bias oscillator does not oscillate.	2. Change oscillator tube EL95.
	3. Faulty recording head.	3. Replace both heads.
	4. Faulty output transformer, T2.	4. Replace output trans- former, T2.
	5. Low B+.	5. Check rectifier.
No playback.	1. Faulty switching.	1. Adjust.
	2. Bias oscillator oscillates in playback position.	2. Correct switching.
Cuts off at 5,000 cps in 3 3/4 ips position.	1. Absorption coil L2 improperly adjusted.	1. See "Absorption Coil" under "Adjustments".
	2. Recording made with gap of recording head in different position.	2. Realign head.
	3. Worn head.	3. Replace both heads.
	4. Dirty head.	4. Clean head.
Too much treble response on playback,	1. Absorption coil L2 improperly adjusted.	1. See "Absorption Coil" under "Adjustments."
High background noise on erased tape.	1. Tape guides or heads magnetized.	1. Demagnetize tape guides or heads.
Crackle in playback position when motor is running.	1. Lead touches rotating cage motor.	1. Correct.
Hum when recording from microphone.	1. Stray AC fields.	1. Correct.

GRUNDIG MAJESTIC MODELS
TK830, TK830E, TK830U

FOLDER 5

MECHANICAL PARTS LIST

Ref. No.	Part No.	Description
1	5024-004	Cast Top Frame
2	0279-284	Complete Clutch
3	0279-285	Upper Clutch Spindle
4	5021-051	Complete Clutching Coil
5	9604-319	Plastic Washer (Simrit White) 26 x 8.2 x 0.2
6	0279-296	Clutching Disc
7	9604-321	Plastic Washer (Simrit White) 15 x 6.1 x 0.3
8	0279-293	Clutch Drive Pulley
9	9604-726	Steel Washer 15 x 8.2 x 0.2
10	9604-320	Plastic Washer (Simrit) 15 x 8.2 x 0.5
11	0279-303	Locking Nut (2)
12	7882-006	Complete Motor 50/60 cps
13	0354-031	Uni-directional Drive Pulley (Left Locking)
14	0354-034	Uni-directional Drive Pulley (Right Locking)
15	0354-330	Drive Belt (Motor-Uni-directional Drive Pulley) (2)
16	0354-331	Drive Belt (Uni-directional Drive Pulley Clutch) (2)
17		Drive Belt For Tape Counter Tape Counter
18	5021-018	Outer Tape Guide Post (2)
19	0628-124	Bracket For Erasing Head (2)
20	7485-512	Erasing Head (2)
21	7489-008	Erasing Head (2)
22	7485-533	Left Hand Base Assembly For Rec./Rep. Head
23	7489-001	Rec./Rep. Head (2)
24	0279-048	Inner Tape Guide Post (2)
25	9619-518	Compression Spring For Inner Tape Guide Post
26	7485-537	Right Hand Base Assembly For Rec./Rep. Head
27	7485-560	Complete Pressure Solenoid
28	7485-563	Complete Slider With Lifting Post For Pressure Roller
29	7485-514	Spring Clamp
30		Upper Clutch Spindle Securing Bracket
31	7485-516	Extension Spring (2)
32	7485-564	Compression Spring (2)
33	0607-050	Complete Crepe Rubber Pres- sure Roller With Fittings (2)
34	0279-044	Pressure Roller
35	5021-080	Complete Two-Speed Selector
36	0354-271	Rubber Buffers (6)
37	0279-210	Washers For 36 (6)
38	5021-039	Complete Top Deck With English Descriptions
39	5016-044	Plastic Head Cover
40	9628-220	Grundig Emblem
41	5021-037	Operating Indicator Plate With English Descriptions
42	0354-006	Scale For Recorder Level Control
43	0607-061	Two-Speed Indicator Plate English
44	5016-047	Perspex Window For Tape Counter
45	5021-032	Perspex Window For Input Selector

Ref. No.	Part No.	Description
46		Tone Control
47	5021-036	Scale For Volume Control
48	5016-051	Complete Plastic Sound Channel Cover
49	5016-052	Golden Finished Insert For (48)
50	5016-053	Clover Emblem
51	7482-002	Push Button Assembly
52	7482-511	Medium Operating Slide For Stop Bar
53	7482-507	Operating Slide (3)
54	7482-508	Operating Slide (3)
55	7482-513	Small Operating Slide (Left Hand)
56	7482-515	Small Operating Slide (Right Hand)
57	7482-536	Compression Spring (9)
58	7482-537	Extension Spring (3)
59	7482-567	Spring Set Ass'y. (With Con- tacts e 1-2-3)
60	7482-544	Spring Set Ass'y. For Stop With Contacts
61	7482-557	Spring Set Ass'y. For Cut Off Speaker, And Erase Current With Contact t 1-2-3
62	7482-561	Left Hand Switch Bank Ass'y.
63	7482-562	Right Hand Switch Bank Ass'y.
64	0279-044	Five Pin Plug (4)
65	0354-079	Shaft For Extension Piece (2)
66	5024-039	Centrifugal Switch
67	5024-040	Spring Set Ass'y. For Centrifu- gal Switch
68	7481-007	Hi-Fi Multisonic Tone Control
69	7481-009	Input Selector
70	7482-539	Stop Bar
71	7482-538	Press Button (6)
72	7482-540	Recording Safety And Temp. Stop Button (Red)
73	7482-541	Trick And Speaker On-Off But- ton (Black)
74	7485-004	Complete Sound Channel Ass'y.
75	5021-082	Spring Set Ass'y. For Two Speed Selector
76	0351-013	Complete Extension Piece
77	0810-018	6-Way Plug With Guide Pins
78	0810-019	6-Way Jack
79	0810-022	5-Way Plug
80	0810-023	5-Way Jack
81	9631-308	Wire Guard
82		Line Cord
83	0279-234	Voltage Tapping Plug
84	7689-010	Voltage Selector
85	0279-226	Screw Plug For Fuse
86	9625-621	Complete Hi Fi Panorama Speak- er Socket
87	0154-017	Complete Ground Socket
88	5844	3-Way Jacks (4)
89	5021-030	Complete Back Socket
90		Speaker Jack
91	7482-526	Complete Switching Slide Short
92	7482-524	Complete Switching Slide Long
93	7482-522	Complete Locking Slide Lower
94	5016-058	Two Speed Selector Knob
95	0809-014	Control Knobs (2)
96	0600-098	Screening Hood (2)
97		Remote Control Socket

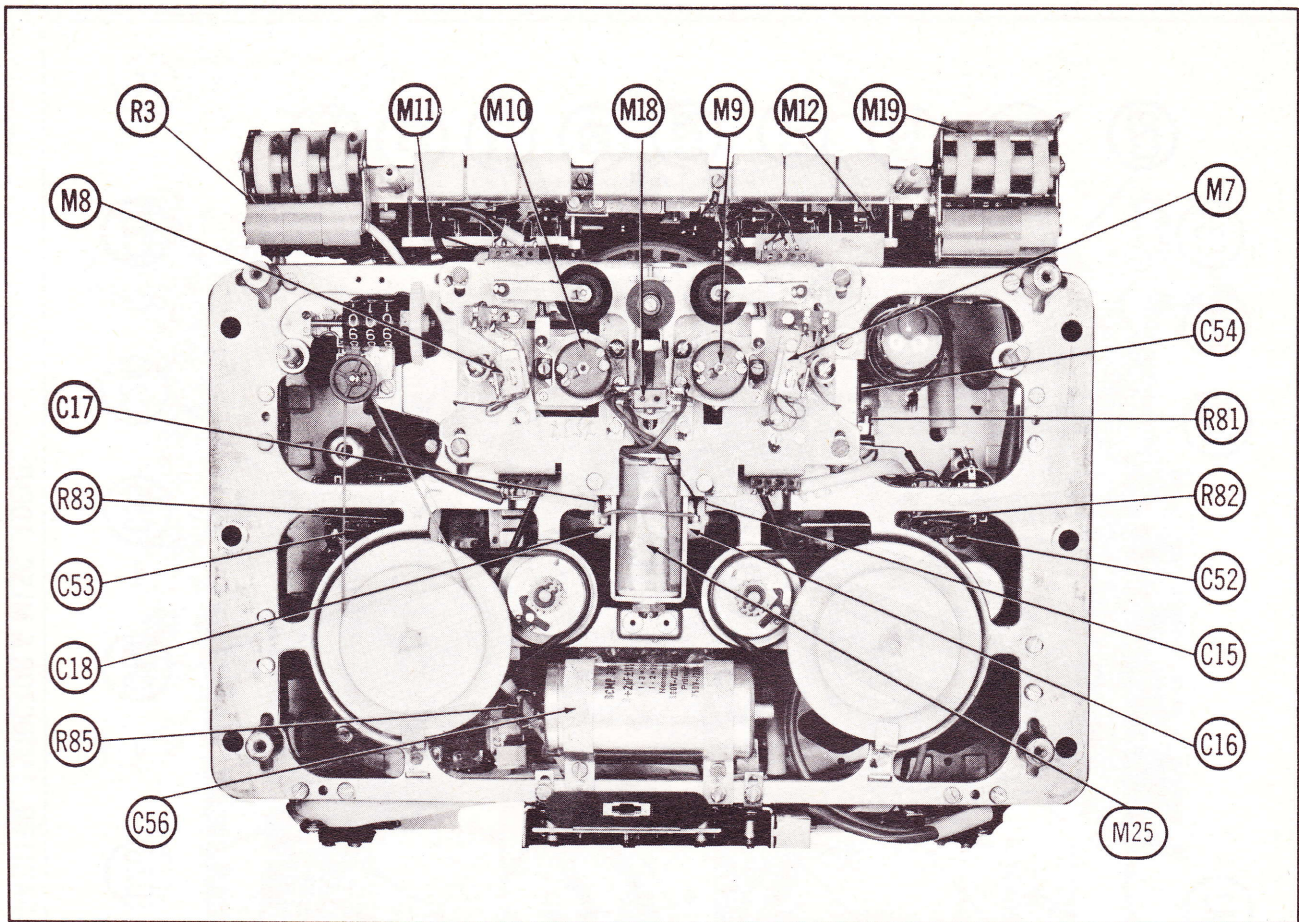

TOP VIEW OF MECHANISM WITH TOP PLATE REMOVED.

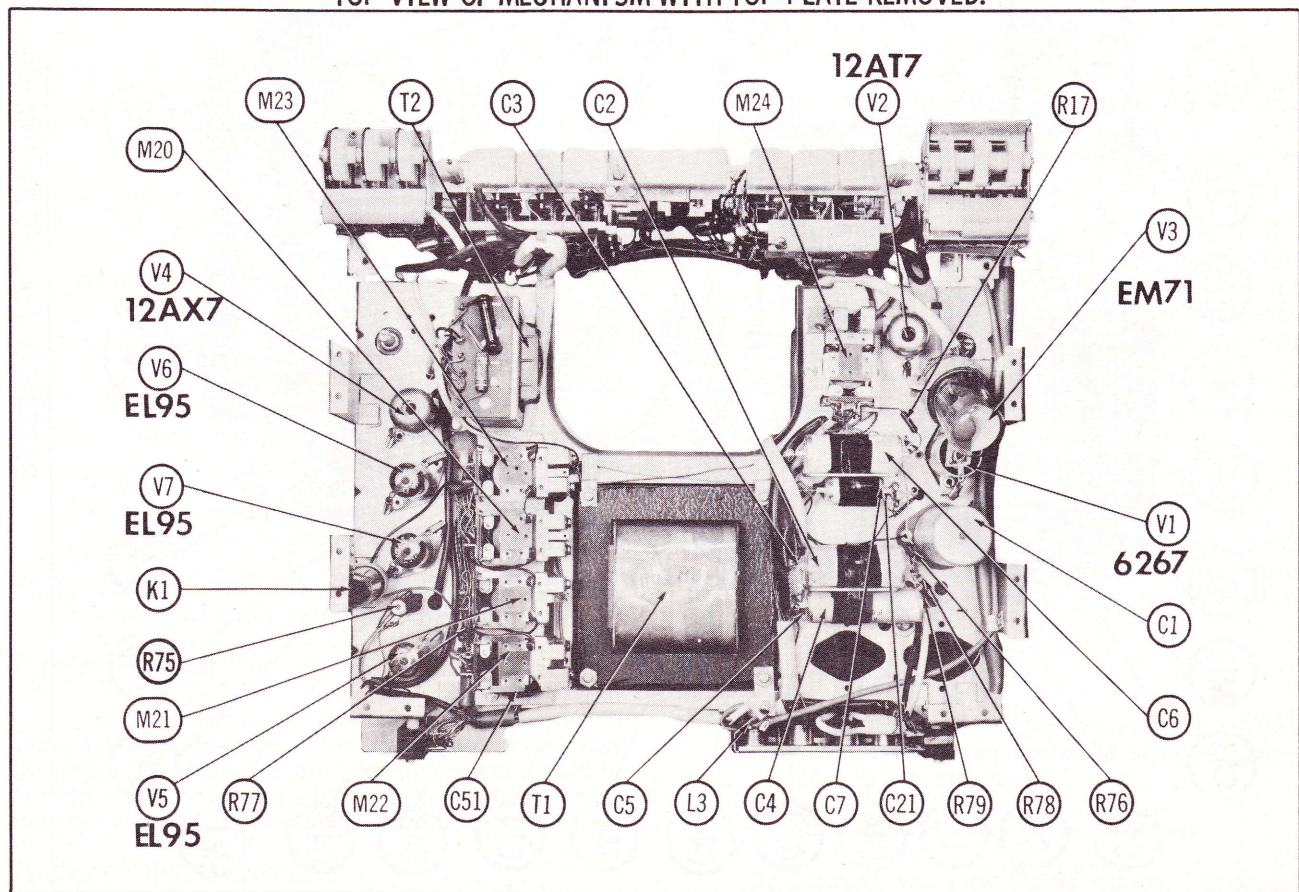

TOP VIEW OF MECHANISM WITH TOP PLATE & FRAME ASS'Y. REMOVED

GRUNDIG MAJESTIC MODELS
TK830, TK830E, TK830U

FOLDER 5

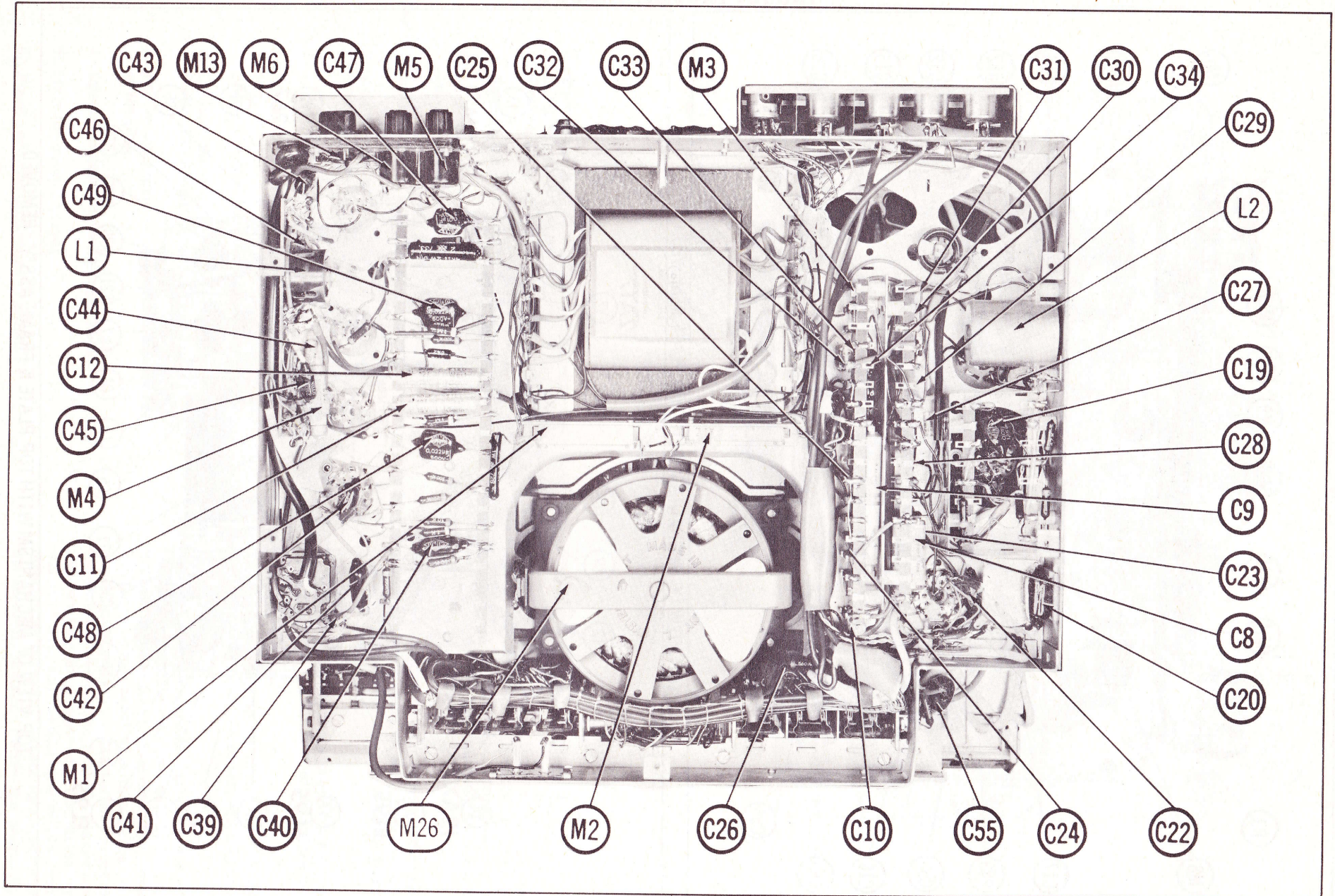

ELECTRICAL CHASSIS BOTTOM VIEW - CAPACITOR, INDUCTOR & MISC. IDENT.

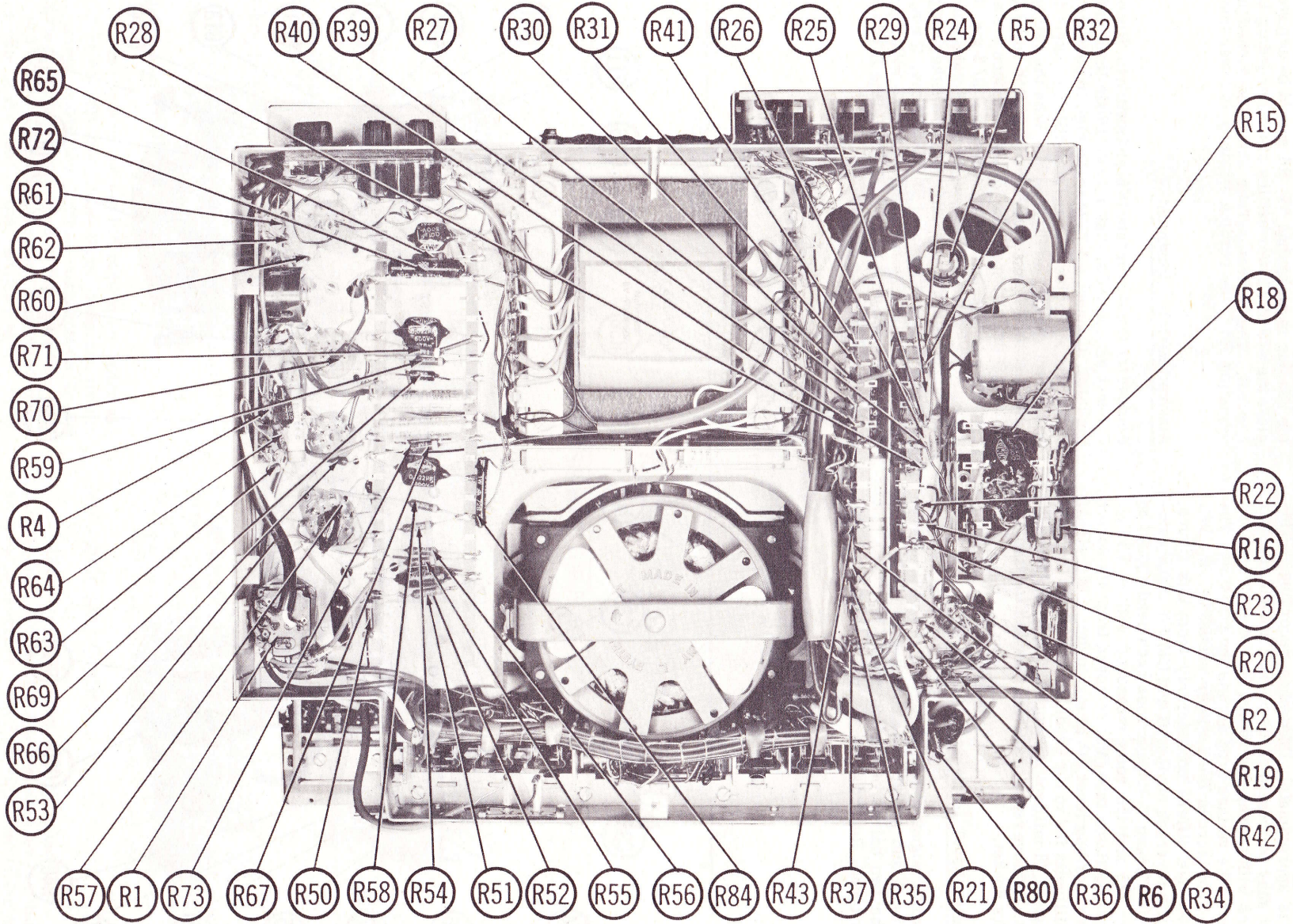

GRUNDIG MAJESTIC MODELS
TK830, TK830E, TK830U
 ELECTRICAL CHASSIS BOTTOM VIEW - RESISTOR IDENT.

ELECTRICAL ADJUSTMENTS

Adjustment of Head Currents

The Bias Current to each of the Recording/ Playback Heads is approximately 1MA when recording. This current may be measured by placing a 200Ω resistor in series with the chassis return lead of each head and measuring the voltage drop across the resistor. The voltage drop across the resistor should be $.2 \pm 10\%$. If the Voltage differs considerably from this figure, adjust C18 for track number II and C16 for track number I. The Erase Voltage across each head should be between 125 and 150 volts measured with a VTVM. With the oscillator tube (V5) removed from its socket and the recording level set at maximum, a 1KC signal at 5 millivolts fed to the Diode Socket should provide a voltage of 16 millivolts across the 200 ohm test resistors. Remove resistors after adjustments. Replace V5 in its socket.

Modulation Level Adjustments

Feed a 1KC signal at a level of 20 millivolt into the Diode Input and adjust the Recording Level Control until the two halves of the Indicator Tube (V3) just begin to touch. Record and measure the third harmonic

distortion content on playback by means of a Distortion meter. The reading obtained should be $4\% \pm 1\%$ with a maximum difference of 2% between track I and II. If the reading is more than 5%, R6 should be adjusted to close the eye at a lower setting of the Recording Level Control. The Indicator Tube should be opened up by adjusting R6 if the reading obtained is lower than 3%.

Absorption Coil Adjustment

Remove the Oscillator tube (V5) and switch to "Record". Connect an Audio Oscillator to the Diode Input and set for 15KC. Connect a VTVM to the high impedance output socket and adjust the audio oscillator output for a convenient reading on the VTVM. With the two speed switch set to $7\frac{1}{2}$ ips, adjust the absorption coil L2 for maximum deflection on the VTVM. Reduce the audio frequency to 9KC and switch speed to $3\frac{2}{3}$ ips. Note the reading on the VTVM and slightly rotate the frequency above and below 9KC noting whether the peak is indicated with a signal of $9KC \pm 300$ cps. If not, the procedure should be repeated, this time with the frequency just above or below 15KC fed to the Diode Input at $7\frac{1}{2}$ ips.

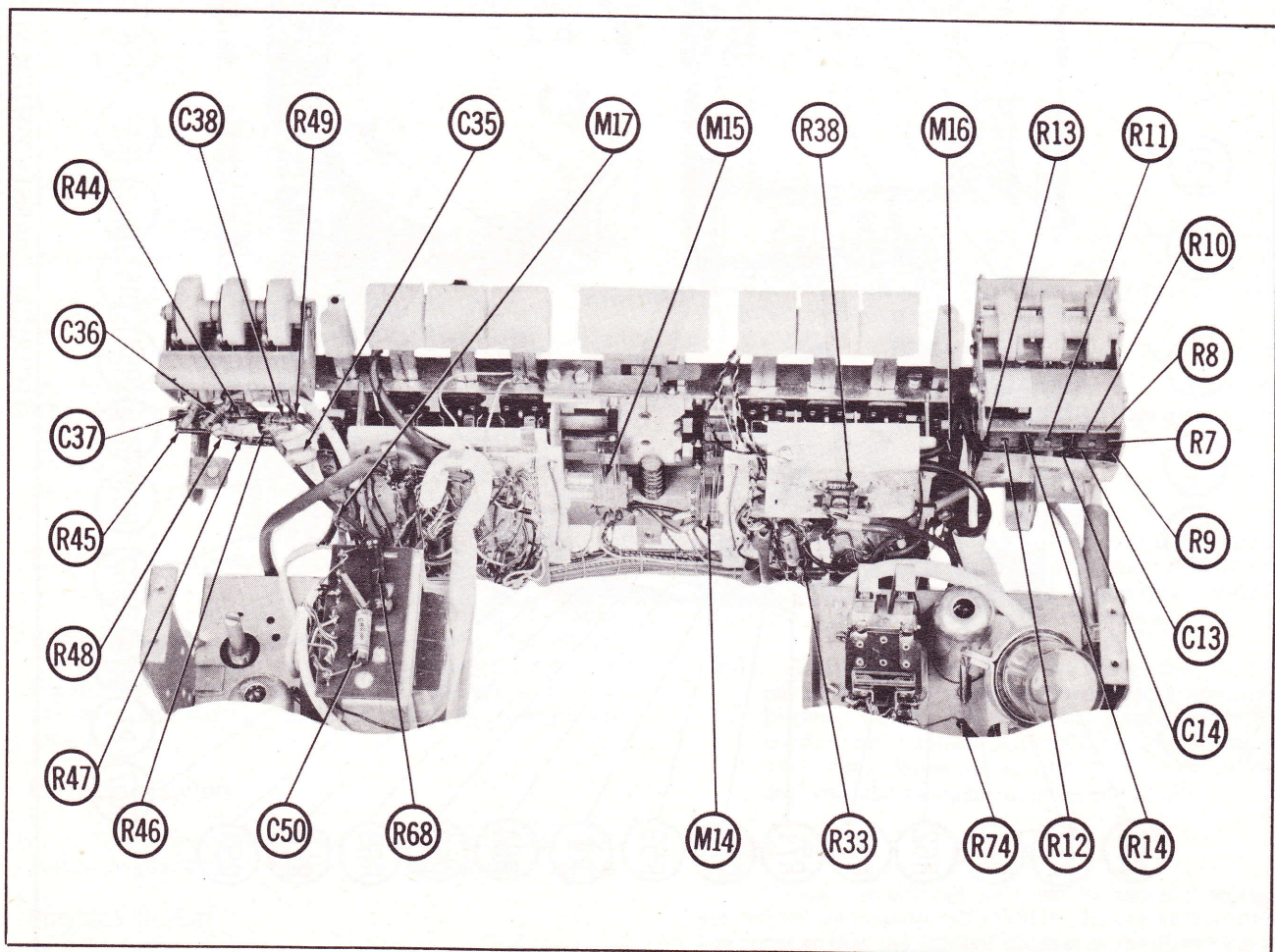

BACK VIEW OF FRONT SWITCH ASSEMBLY

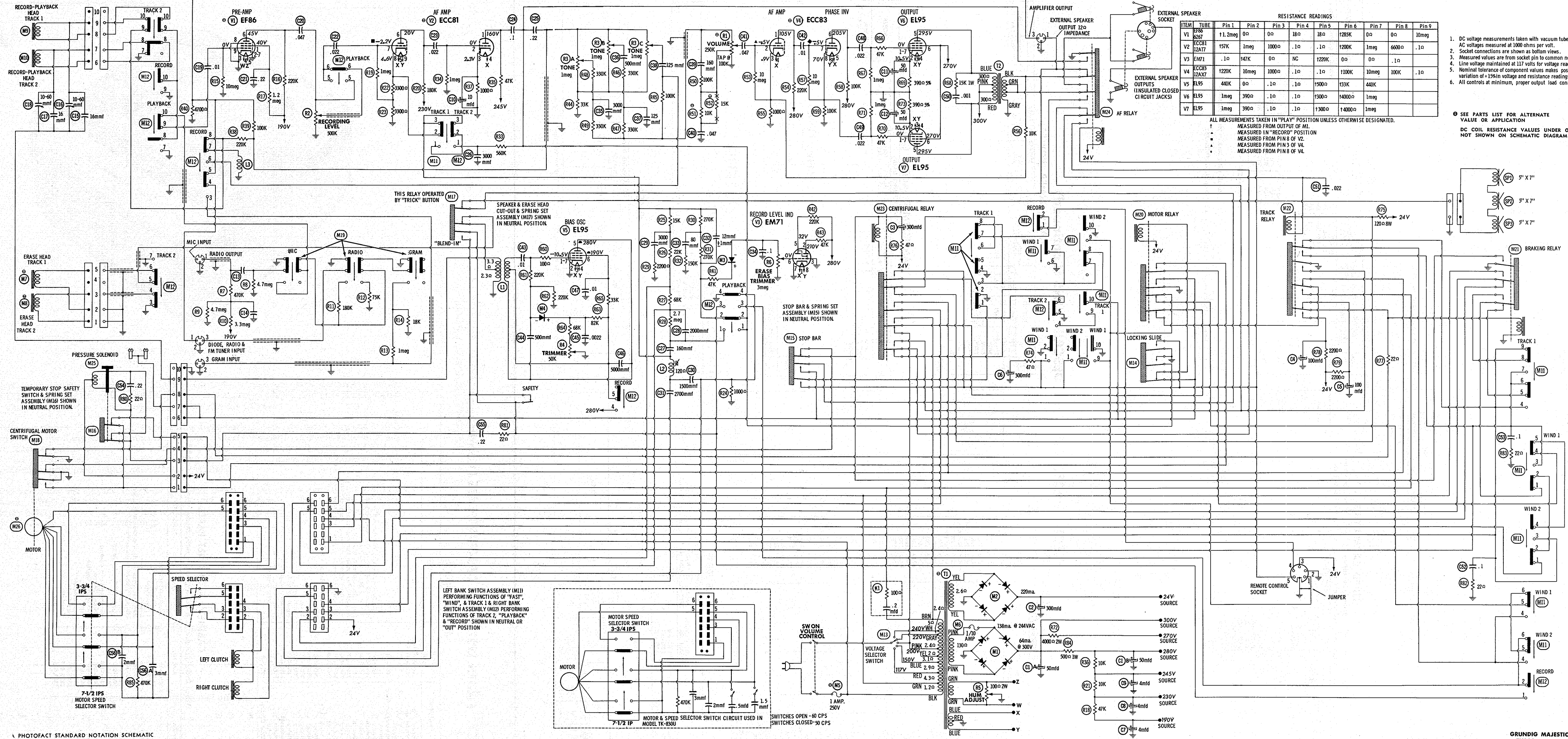

ITEM	TUBE	RESISTANCE READINGS								
		Pin 1	Pin 2	Pin 3	Pin 4	Pin 5	Pin 6	Pin 7	Pin 8	Pin 9
V1	EF86	1.2meg	0 Ω	0 Ω	18 Ω	18 Ω	125K	0 Ω	0 Ω	10meg
V2	ECC81	157K	1meg	1000 Ω	.1 Ω	.1 Ω	1200K	1meg	6000 Ω	.1 Ω
V3	ECC83	1.0	47K	0 Ω	NC	1220K	0 Ω	0 Ω	.1 Ω	
V4	ECC83	1220K	10meg	1000 Ω	.1 Ω	.1 Ω	1100K	10meg	100K	.1 Ω
V5	EL95	440K	0 Ω	.1 Ω	.1 Ω	1500 Ω	133K	440K	100K	
V6	EL95	1meg	390 Ω	.1 Ω	.1 Ω	1300 Ω	14000 Ω	1meg		
V7	EL95	1meg	390 Ω	.1 Ω	.1 Ω	1300 Ω	14000 Ω	1meg		

- DC voltage measurements taken with vacuum tube voltmeter; AC voltages measured at 1000 ohms per volt.
 - Socket connections are shown as bottom views.
 - Measured values are from socket pin to common negative.
 - Line voltage maintained at 117 volts for voltage readings.
 - Nominal tolerance of component values makes possible a variation of $\pm 15\%$ in voltage and resistance readings.
 - All controls at minimum, proper output load connected.
- SEE PARTS LIST FOR ALTERNATE VALUE OR APPLICATION
DC COIL RESISTANCE VALUES UNDER ONE OHM NOT SHOWN ON SCHEMATIC DIAGRAM

PHOTOFACT STANDARD NOTATION SCHEMATIC
© Howard W. Sams & Co., Inc. 1959

GRUNDIG MAJESTIC MODELS
TK830, TK830E, TK830U

ELECT. PARTS LIST AND DESCRIPTIONS

TUBES (GENERAL ELECTRIC, SYLVANIA)

ITEM No.	USE	TYPE
V1	Preampl.	EP86/6267 ⊕
V2	AF Amplifier	ECC81/12AT7 ⊕
V3	Record Level Indicator	EM71
V4	AF Amp-Phase Inv.	ECC83/12AX7 ⊕

ITEM No.	USE	TYPE
V5	Bias Osc.	EL95
V6	Output	EL95
V7	Output	EL95

⊕ Domestic type listed may not be directly interchangeable in some instances.

ELECTROLYTIC CAPACITORS

ITEM No.	RATING		REPLACEMENT DATA						
	CAP.	VOLT.	Grundig Majestic PART No.	AEROVOX PART No.	CORNELL-DUBILIER PART No.	MALLORY PART No.	PYRAMID PART No.	SANGAMO PART No.	SPRAGUE PART No.
C1A	50	385			BR5045				TVLS-2646*
B	50	385			BR5045				
C2	300	35		PRS50V250	BR2505	TD-250-50			TVAS-1225*
C3	300	35		PRS50V250	BR2505	TD-250-50			TVAS-1225*
C4	100	40		PRS50V100	BR1005	TD-100-50	MTH-5010		TVA-1310
C5	100	40		PRS50V100	BR1005	TD-100-50	MTH-5010		TVA-1310
C6	300	35		PRS50V250	BR2505	TD-250-50			TVAS-1225*
C7	4	385		PRS450V4	BR445	TD-4-450	MT-4504		TVAS-1643*
C8	4	385		PRS450V4	BR445	TD-4-450	MT-4504		TVAS-1643*
C9	4	385		PRS450V4	BR445	TD-4-450	MT-4504		TVAS-1643*
C10	10	15		SRE25V10	BBR10-25	TT15X10	ML10-15	MQ-0510	TVA-1204
C11	50	15		SRE25V50	BBR50-25	TT15X50	ML50-15	MQ-0150	TE-1160
C12	50	15		SRE25V50	BBR50-25	TT15X50	ML50-15	MQ-0150	TE-1160

CAPACITORS (cont)

ITEM No.	RATING		REPLACEMENT DATA						NOTES
	CAP.	VOLT	Grundig Majestic PART No.	AEROVOX PART No.	CENTRALAB PART No.	CORNELL-DUBILIER PART No.	MALLORY PART No.	SPRAGUE PART No.	
C28	2000			1467-002	DD-202	1W5D2	MC477	1FM-22	+ 1mmf
C29	3000			1467-003	DD-302	1W5D3	MC461	1FM-23	
C30	1500			1467-0015	DD-152	1W5D15	MC256	1FM-215	
C31	2700			1467-0027	DD-272	1W5D27		1FM-227	
C32	12			1469-000012	TCZ-12	22R5Q12		MS-412	
C33	80								
C34	1	125		P288N-1	DF-104	CUB2P1	GEM-201	2TM-P1	
C35	3000			1467-003	DD-302	1W5D3	MC461	1FM-23	
C36	500			1468-0005	DD-501	5W5T5	MC245	1FM-35	
C37	125								
C38	125								
C39	160			1468-00016		5W5T16			
C40	0.47	125		P288N-047	DF-503	CUB2S47	GEM-4147	2TM-S47	
C41	0.47	125		P288N-047	DF-503	CUB2S47	GEM-4147	2TM-S47	
C42	0.1	500		P688N-01	D6-103	CUB6S1	GEM-611	6TM-S1	
C43	0.1	500		P688N-01	D6-103	CUB6S1	GEM-611	6TM-S1	
C44	500			1468-0005	DD-501	5W5T5	MC245	1FM-35	
C45	0.022	250		P488N-0022	D6-222	CUB6D22	GEM-6222	6TM-D22	
C46	5000			1467-005	DD-502	1W5D5	MC465	1FM-25	
C47	0.1	500		P688N-01	D6-103	CUB6S1	GEM-611	6TM-S1	
C48	0.22	500		P688N-022		CUB6S22	GEM-6122	6TM-S22	
C49	0.22	500		P688N-022		CUB6S22	GEM-6122	6TM-S22	
C50	0.01	500		P688N-001	D6-102	CUB6D1	GEM-621	6TM-D1	
C51	0.022	125		P288N-022	DD-203	CUB4S22	GEM-4122	2TM-S22	Note 1
C52	1	125		P288N-1	DF-104	CUB2P1	GEM-201	2TM-P1	
C53	1	125		P288N-1	DF-104	CUB2P1	GEM-201	2TM-P1	
C54	22	125		P288N-22		CUB2P22	GEM-2022	2TM-P22	
C55	22	125		P288N-22		CUB2P22	GEM-2022	2TM-P22	
C56A3		500							
B 2		500							

Note 1. Not used in some versions.

FIXED CAPACITORS

Capacity values given in the rating column are in mfd. for Paper Capacitors, and in mmfd. for Mica and Ceramic Capacitors.

ITEM No.	RATING		REPLACEMENT DATA							NOTES
	CAP.	VOLT	Grundig Majestic PART No.	AEROVOX PART No.	CENTRALAB PART No.	CORNELL-DUBILIER PART No.	MALLORY PART No.	SPRAGUE PART No.		
C13	10000			SI 10000	D6-103	LT6S1	B-110	5HK-S1	Volume, Tap@100K Note 1	
C14	1	250		P488N-1	DF-104	CUB4P1	GEM-401	4TM-P1		
C15	16									
C16	10-60									
C17	16									
C18	10-60									
C19	0.1	125		P288N-01	D6-103	CUB2S1	GEM-411	2TM-S1		
C20	0.47	500		P688N-047	DF-503	CUB6S47	GEM-6147	6TM-S47		
C21	22	500		P688N-22		CUB6P22	GEM-6022	6TM-P22		
C22	0.22	250		P488N-022		CUB4S22	GEM-6122	4TM-S22		
C23	0.22	500		P688N-022		CUB6S22	GEM-6122	6TM-S22		
C24	1	500		P688N-1	DF-104	CUB6P1	GEM-601	6TM-P1		
C25	22	125		P288N-22		CUB2P22	GEM-2022	2TM-P22		
C26	3000			1467-003	DD-302	1W5D3	MC461	1FM-23		
C27	160			1468-00016		5W5T16				

CONTROLS

ITEM No.	RATING		REPLACEMENT DATA						INSTALLATION NOTES
	RESISTANCE	WATTS	Grundig Majestic PART No.	CENTRALAB PART No.	CLAROSTAT PART No.	IRC PART No.	MALLORY PART No.		
RIA	250K	1/2		BT-53 †	A47F1-250K	Q13-130X	U46	Volume, Tap@100K Note 1 Recording Level Tone Tone Tone Trimmer Hum Adjust Erase Bias Trimmer	
B	Shaft			Not Req.	KSS-3	PQ †	Not Req.		
C	Switch			KB-2 or KR-2*	SWE-20	76-2	US-27		
R2A	500K	1/2	5021-015	B-60 †	A47-500K-Z	Q13-133	U48		
B	Shaft			Not Req.	KSS-3	PQ †	Not Req.		
R3A	1meg	1/4	7481-007						
B	1meg	1/4							
C	1meg	1/4							
R4A	50K	1/4		AB-31 ♦	A47-50K-S ♦	Q11-123 ♦	U35 ♦		
B	Shaft			AK-1	FKS-1/4	RQ	Not Req.		
R5A	100Ω	2(WW)	1532	WN-101	A43-100	W11-084 ▲	R100L ▲		
B	Shaft			Not Req.	FKS-1/4	SK5	Not Req.		
R6	3meg	1/4							

* Use KR-2 with CRL "Red Label" controls and KB-2 with "Blue Label" controls.
 † Saw off shaft and add slot as required.
 ♦ Enlarge mounting hole to 3/8".
 ▲ To use standard bushing type control, relocate filter bank on top of chassis and enlarge mounting hole to 3/8".

Note 1. A 650K control may be used in some versions (Part #5021-016).

ELECT. PARTS LIST AND DESCRIPTIONS (Continued)

RESISTORS

All wattages 1/2 watt, or less, unless otherwise listed.

ITEM No.	RATING		Grundig Majestic PART No.	NOTES	ITEM No.	RATING		Grundig Majestic PART No.	NOTES
	OHMS	WATT				OHMS	WATT		
R7	470K				R47	330K			Note 1 Note 1
R8	4.7meg				R48	330K			
R9	4.7meg				R49	330K			
R10	3.3meg				R50	100K			
R11	180K				R51	10K			
R12	75K				R52	15K			
R13	1meg				R53	10meg			
R14	18K				R54	220K			
R15	10meg				R55	1000Ω			
R16	220K				R56	10K			
R17	1.2meg				R57	10meg			
R18	47K				R58	100K			
R19	1meg				R59	100K			
R20	180K				R60	100Ω			
R21	10K				R61	220K			
R22	3300Ω				R62	220K			
R23	3300Ω				R63	82K			
R24	1000Ω				R64	68K			
R25	15K				R65	33K			
R26	22K				R66	47K			
R27	68K				R67	1meg			
R28	2.7meg				R68	15K	1		
R29	2200Ω				R69	390Ω 5%			
R30	270K				R70	47K			
R31	270K				R71	1meg			
R32	150K				R72	4000Ω	2		
R33	560K				R73	390Ω 5%			
R34	1meg				R74	47Ω			
R35	47K				R75	120Ω			
R36	10K				R76	47Ω	8		
R37	1000Ω				R77	22Ω			
R38	220K				R78	2200Ω			
R39	100K				R79	2200Ω			
R40	4700Ω				R80	22Ω			
R41	47K				R81	22Ω			
R42	220K				R82	22Ω			
R43	47K				R83	22Ω			
R44	33K				R84	500Ω	1		
R45	100K				R85	470K			
R46	330K								

Note 1. Some versions may use a 5600Ω resistor to replace R51 & R52.

COILS (RF-IF)

ITEM No.	USE	REPLACEMENT DATA					NOTES
		Grundig Majestic PART No.	Meissner PART No.	Merit PART No.	Miller PART No.	Ram PART No.	
L1	Bias Osc.	9281-006					
L2	Trap Coil	9281-003					
L3	Hum Pickup Coil	9281-026					

SPEAKER

ITEM No.	TYPE			REPLACEMENT DATA		NOTES
	SIZE	FIELD	V. C. IMP.	Grundig Majestic PART No.	QUAM PART No.	
SP1	5" x 7"	PM	3-4Ω	0459/19		
SP2	5" x 7"	PM	3-4Ω	0459/19		
SP3	5" x 7"	PM	3-4Ω	0459/19		

TRANSFORMER (POWER)

ITEM No.	RATING			REPLACEMENT DATA						
	PRI.	SEC. 1	SEC. 2	Grundig Majestic PART No.	Halldorson PART No.	Merit PART No.	Ram PART No.	Stancor PART No.	Thordarson PART No.	Triad PART No.
T1	260V Tap @	240V @ .138A	24V @ .44A	9008-507 ① 9008-506 ② 9008-503 ③						
	240V, 220V, 200V, 185V, 150V, 117V @ 95A, 35V.	SEC. 3 6.3 VCT @ 2A	SEC. 4 6.3V @ .2A							

① Used in 60Ω Models ② 50/60% Part No. ③ 50% Part No.

TRANSFORMER (AUDIO OUTPUT)

ITEM No.	IMPEDANCE		REPLACEMENT DATA						NOTES	
	PRI.	SEC.	Grundig Majestic PART No.	Halldorson PART No.	Merit PART No.	Ram PART No.	Stancor PART No.	Thordarson PART No.		Triad PART No.
T2	4400Ω	8Ω	9060-501	Z1011 ①	A-2901 ①	AU-609 ①	A-3870 ①	24S61 ①	S-55X ①	① Drill new mounting hole
	PRI. 2	SEC. 2								
	4400Ω	3.4Ω								

COMPONENT COMBINATIONS

ITEM No.	USE	DESCRIPTION	Grundig Majestic PART No.	REPLACEMENT DATA
K1	Motor Reversing Network	.2mfd 100Ω		

SELENIUM RECTIFIER

ITEM No.	RATING		REPLACEMENT DATA				NOTES
	CURRENT (Measured)	8Ω	Grundig Majestic PART No.	FEDERAL PART No.	INTERNATIONAL PART No.	SARKES TARZIAN PART No.	
M1	.064A		B250C100				
M2	.220A		B30C600				
M3			E25C5				
M4			E150C2		U25HFP		

FUSES

ITEM No.	TYPE	RATING	REPLACEMENT DATA						
			Grundig Majestic PART No.		LITTELFUSE PART No.		BUSS PART No.		
			FUSE	HOLDER	FUSE	HOLDER	FUSE	HOLDER	
M5		1A 250V*		0279-226					
M6		1/10A 250V							

* Some versions may use 1 1/4A fuse in this application, 200-240V line source uses .8A or 1A.

ELECT. PARTS LIST AND DESCRIPTIONS (Continued)

MISCELLANEOUS

ITEM No.	PART NAME	Grundig Majestic PART No.	NOTES
M7	Erase Head	7489-008/ 011	
M8	Erase Head	7489-008/ 011	
M9	Record-Playback Head	7489-001	
M10	Record-Playback Head	7489-001	
M11	Switch	7482-561	Left Bank Assembly, Fast Rewind
M12	Switch	7482-562	Right Bank Assembly, Playback, Record
M13	Switch	7689-010	Voltage Selector And Plug #0279-234
M14	Switch	7482-567	Spring Set Assembly With Contacts
M15	Switch	7482-544	Spring Set Assembly For Stop With Contacts
M16	Switch	7482-545	Spring Set Assembly, Pressure Magnet Cut Off
M17	Switch	7482-557	Spring Set Assembly, Speaker And Erase Head Cut Off
M18	Switch	5024-039	Centrifugal
M19	Switch Ass'y.		Input (Mic, Radio, Gram)
M20	Relay	7680-012	Motor
M21	Relay	7680-027	Braking
M22	Relay	7680-011	Track
M23	Relay	7680-026	Centrifugal
M24	Relay	7680-022	Signal Control
M25	Solenoid	9281-015	Pressure Magnet
M26	Motor	7882-006	50-60 Cycle, Complete
	Motor	7882-001	50 Cycle, Complete
	Tape Counter	5021-018	

CABINETS & CABINET PARTS

(When Ordering Cabinets & Cabinet Parts, Specify Model, Chassis & Color)

NAME	PART NO.	DESCRIPTION
Knob	5016-058	Two Speed Selector
Knob	0809-014	Control (2 Used)
Button	7482-002	Press Block
Press Button	7482-538	6 Used
Stop Button	7482-540	Red, Recording Safety And Temperature Stop
Button	7482-541	Black, Trick And Speaker On-Off
Head Cover	5016-044	
Cover	5016-050	Complete, Sound Channel
Cover Plate	7682-513	
Scale	0354-006	Recording Level Control
Scale	5021-036	Volume Control
Indication Plate	0607-061	Two Speed, English
Window	5016-047	Tape Counter
Window	5021-032	Input Selector
Window	5021-035	Tone Control
Handle	0630-087	Complete
Case	7682-001	Complete

WIRING DATA

General-use Unshielded Hook-up Wire	Use BELDEN No. 8530 (Solid) Available in Ten Colors 8524 (Stranded) Available in Ten Colors
Power Cord	Use BELDEN No. 1765-B (6 Ft. Length) 1725-K (7½ Ft. Length)