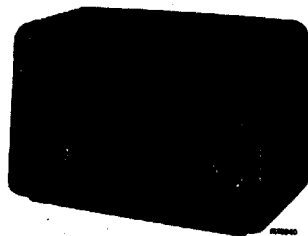

PHILIPS

SERVICE DOCUMENTATIE

voor de ontvanger

B5 X 65 A

1956

Voor voeding uit wisselstrommetten.

Golfbereiken

M.G.	: 185	- 580	m	(1622	- 517	kHz
K.G.3	: 59	- 187	m	(5,1	- 1,6	MHz
K.G.2c	: 25	- 60	m	(12	- 5	MHz
K.G.2b	: 16,75	- 25,64	m	(17,9	- 11,7	MHz
K.G.2a	: 11,4	- 16,94	m	(26,2	- 17,7	MHz

M.F. : 452 KHzNetspanningen.

90-110-127-145-190-220 V.

Verbruik.

ca. 60 W.

Knoppen.

Van links naar rechts :

Lage tonenregelaar,

Volumeregelaar.

Druktoetsen : Uitschakelaar.

P.U.-M.G.-K.G.3-K.G.2c-K.G.2b-K.G.2a.

Ferroceptor.

Afstemming.

Hoge tonenregelaar.

Luidspreker.

AD 3690 AM (Z = 800 Ω)

Schaallampjes.

8024N-91

Buizen

B1 : EF89	B5 : EL84
B2 : ECH81	B6 : EM80
B3 : EBF80	B7 : EZ80
B4 : EBC81	B8 : UL41

Afmetingen

510 x 343 x 256 mm

Bandbreedte.

De M.F. bandbreedte (1:10) gemeten aan g1B2 bedraagt ongeveer 10,5 kHz.

De totale bandbreedte (1:10) gemeten aan de antennebus bedraagt ongeveer 9 kHz bij 1622 kHz en ongeveer 7,5 kHz bij 550 kHz.

Raamantenne.

Voor de kortegolgbereiken wordt gebruik gemaakt van een raamantenne, die automatisch uitgeschakeld wordt bij aansluiting van een buitenantenne. De U.G. antennekring is uitgevoerd als ferroceptor.

Afregelen van de ontvanger

M.F. Bandfilter.

1. Volumeregelaar op maximum.
2. Gelthareikschakelaar op M.G.
3. Afstemcondensator op minimum.
4. De kernen der M.F. bandfilters zo ver mogelijk uitdraaien.
5. Een voltmeter via een trimtransformator op de aansluitbussen voor de extra luidspreker aansluiten.
6. Een gemoduleerd signaal van 452 kHz via een condensator van 33.000 pF aan g1B2 toevoeren.
7. De M.F. kringen op maximum output in de volgorde S28, S27, S25, S26, S27 afregelen.
8. De kernen der M.F. bandfilters aflakken.

H.F.- en Oscillatorkringen.

Het afregelen geschiedt met behulp van de trimpunten op de schaal. Trimpunt 1 links, trimpunt 2 rechts. Stel de wijzer op trimpunt 1 in bij minimum stand van de condensator.

1. Volumeregelaar op maximum.
2. Een voltmeter via een trimtransformator op de aansluitbussen voor de extra luidspreker aansluiten.
3. Wanneer in de trimpunten aangegeven is dat het signaal toegevoerd moet worden aan 2 punten op het chassis dan gebruikt men de punten X en Y aangegeven in fig. 3.
X - Y = 10 cm.
De hierdoor in de montageplaat vloeiende stroom zorgt n.l. voor een zwakke koppeling met de raamantenne.

Golfbereik schakelaar op	Wijzer op trimpunt	Gemoduleerd signaal			Trim op max. output
		van	via	aan	
M.G.	2	550 kHz	kunst- antenne	antenne- bus	S24; S15; S10, S10a
	1	1630kHz	kunst- antenne	antenne- bus	C36; C24 C14
K.G.3	2	1,72MHz	33000pF	g1B1 X - Y	S22; S14-S14a S9
	1	5,15MHz	33000pF	g1B1 X - Y	C35; C23 C12
K.G.2c	2	5,26MHz	33000pF	X - Y	S7
	1	12,1MHz	33000pF	g1B1	C62
K.G.2b	2	11,75MHz	33000pF	g1B1	S19; S12
	1	18 MHz	33000pF	g1B1 X - Y	C40; C21 C10
K.G.2a	2	17,8MHz	33000pF	g1B1	S17; S11
	1	26,4MHz	33000pF	g1B1 X - Y	C39; C20 C8
<u>Trimmen van raamvervangingspoel</u>					
K.G.2c	2	5,26MHz	kunst- antenne	antenne- bus	S5
K.G.2a	1	26,4MHz	kunst- antenne	antenne- bus	C66

Lak de kernen en trimmers af.

Voedingstransformator.

De originele voedingstransformator moet bij defect raken vervangen worden door de standaard transformator genoemd in de elektrische stuklijst. Voor de aansluitingen zie fig. 2.

Snaraandrijving.

Voor de loop en lengten der snaren zie fig. 1.

Spanningen.

De spanningen zijn aangegeven in het principeschema en zijn gemeten met de GM 4257.

LIJST VAN ONDERDELEN

	Omschrijving	Code nummer
	Kast	A3 770 57.0
	Knop (klein)	A3 751 59.0
	Knop (groot)	A3 751 61.0
	Bladveer voor grote knop	A3 650 18.0
	Bladveer voor kleine knop	A3 522 08.2
	Toets	A3 417 75.0
	Knop voor toonregeling	A3 752 69.0
	Netschakelaar	A3 182 78.0
	Trekveer voor netschakelaar	A3 646 06.0
	Variabele condensator	49 001 97.0
	Spanningsomschakelaar	A3 228 85.0
	Bladveer voor spoelbevestiging	A3 651 89.0
	Veer voor dubbele spoelbus bevestiging	A3 652 58.3
	Veer voor enkele spoelbus bevestiging	A3 652 75.1
	Trekveer in trommel variabele condensator	89 312 10.3
	Veer in aandrijfsnaar	A3 646 23.0
	Tule kleur HA schaalbevestiging	P5 420 03/08
	Trommel ferroceptor	P4 380 53.0
	Veer in trommel ferroceptor	89 312 10.3
	Schakelaar antenne-ferroceptor	A3 186 83.0
	Strip (5x) golfbereikschakelaars	A3 664 27.0
	Trekveer drukknop unit	A4 601 24.0
	Drukveer drukknop unit	A3 644 99.0
	Schaal overzee	A3 806 89.0
	Schaal Mid. zee	A3 806 87.0
		<i>WJ</i>
	WM/LM	

S1)			C12	22 pF	49 005 59.4
S2)		A3 141 37.5	C13	3000 pF	A9 999 05/3K
S3)			C14	22 pF	49 005 59.4
S5		A3 119 41.0	C15	100 pF	A9 999 04/100E
S6		A3 119 42.0	C16	10.000 pF	A9 999 04/10K
S7		A3 119 43.0	C17	106 pF	A9 999 05/100E
S9		A3 119 50.0	C18	150 pF	A9 999 05/6E2
S10a)			C19	10.000 pF	A9 999 04/150E
S10a)		A3 118 35.0	C20	22 pF	A9 999 04/10K
S11		A3 119 53.0	C21	30 pF	28 212 36.4
S12		A3 119 49.0	C22	3000 pF	A9 999 05/3K
S13		A3 119 44.0	C23	22 pF	49 005 59.4
S14)		A3 119 45.0	C24	22 pF	49 005 59.4
S14a)			C25	65 pF	A9 999 04/47E
S15		A3 125 48.0	C26	120 pF	A9 999 04/18E
S16)			C27	100 pF	A9 999 05/120E
S17)		A3 119 46.0	C28	390 pF	A9 999 04/100E
S18)			C29	68 pF	A9 999 04/390E
S19)		A3 119 47.0	C30	120 pF	A9 999 04/68E
S20		A3 118 45.0	C31	10.000 pF	A9 999 05/120E
S20a)			C32	82 pF	A9 999 04/10K
S20b)		A3 119 51.0	C33	455 pF 2x	A9 999 04/82E
S21)			C34	56 pF	A9 999 05/910E
S22)		A3 119 48.0	C35	20 pF	A9 999 05/56E
S23)			C36	30 pF	49 005 59.4
S24)		A3 125 93.0	C37	zie spoelen	28 212 36.4
S25			C38	voir bobines	véase bobinas
S26			C39	30 pF	see coils
C37	110 pF	A3 126 84.0	C40	30 pF	28 212 36.4
C38	195 pF		C41	33000 pF	28 212 36.4
S27			C42	10 pF	A9 999 06/33K
S28			C43	zie spoelen	A9 999 04/10E
C43	110 pF	A3 126 84.0	C44	voir bobines	véase bobinas
C44	195 pF		C45	47 pF	see coils
C1	50 μ F	A9 999 13/	C46	10.000 pF	A9 999 04/47E
C1a	50 μ F	M50+50+50	C47	3300 pF	A9 999 04/10K
C2	50 μ F		C48	8200 pF	A9 999 06/3K3
C4	12,5-489 pF		C49	22.000 pF	A9 999 06/8K2
C5	12,5-489 pF	49 001 97.0	C50	10.000 pF	A9 999 06/22K
C6	12,5-511 pF		C51	0,1 μ F	A9 999 04/10K
C8	30 pF	28 212 36,1	C52	47.000 pF	A9 999 06/100K
C9	33 pF	A9 999 04/33E	C53	6.800 pF	A9 999 06/47K
C10	12 pF	49 005 64.2	C54	8 μ F	A9 999 06/6K8
C11	100 pF	A9 999 07/20E-100E	C55	100 μ F	A9 999 11/L8
			C56	390 pF	A9 999 10/C100
			C57	680 pF	A9 999 04/390E
			C58		A9 999 04/680E
			C59	2200 pF	A9 999 06/2K2
			C60	12 pF	A9 999 04/12E
			C61	10 pF	A9 999 04/10E
			C62	30 pF	28 212 36,4
			C63	2100 pF	A9 999 05/1K8+100E
			C64	4,7 pF	A9 999 04/4E7

C65	10 pF	A9 999 04/10E	R24	27.000 Ω	A9 999 00/27K
C66	30 pF	28 212 36.4	R25	0,33 MΩ	A9 999 00/330K
C67	10 pF	A9 999 04/10E	R26	0,05 MΩ	A9 999 16/
C68	10.000 pF	A9 999 04/10K	R27	0,45 MΩ	GL50K + 450K
C69	0,1 μF	A9 999 06/100K	R28	1.000 Ω	A9 999 00/1K
C70	68.000 pF	A9 999 06/68K	R29	100 Ω	A9 999 00/180E
R1	100 Ω	A9 999 00/100E	R30	10.000 Ω	A9 999 00/10K
R2	10.000 Ω	A9 999 00/10K	R31	0,4 MΩ	A9 999 16/
R3	1 MΩ	A9 999 00/1M	R31a	1,6 MΩ	GL400K+1M6
R4	0,1 MΩ	A9 999 00/100K	R32	0,1 MΩ	A9 999 00/100K
R5	22.000 Ω	A9 999 00/22K	R33	0,18 MΩ	A9 999 00/180K
R6	150 Ω	A9 999 00/150E	R34	18 Ω	A9 999 00/18E
R7	1 MΩ	A9 999 00/1M	R35	1500 Ω	A9 999 00/1K5
R8	39.000 Ω	A9 999 00/39K	R36	68.000 Ω	A9 999 00/68K
R9	47.000 Ω	A9 999 00/47K	R37	0,1 MΩ	A9 999 00/100K
R10	47.000 Ω	A9 999 00/47K	R38	1.500 Ω	A9 999 00/1K5
R11	1 MΩ	A9 999 00/1M	R39	1.500 Ω	A9 999 00/1K5
R12	1,2 MΩ	A9 999 00/1M2	R40	6.800 Ω	A9 999 00/6K8
R13	0,33 MΩ	A9 999 00/330K	R41	270 Ω	A9 999 00/270E
R14	2,2 MΩ	A9 999 00/2M2	R42	56 Ω	A9 999 00/56E
R15	68.000 Ω	A9 999 00/68K	R43	56 Ω	A9 999 00/56E
R16	1,6 MΩ	A9 999 16/160K	R44	270 Ω	A9 999 00/270E
R17	0,4 MΩ	+ 1M6	R45	600 Ω	A9 999 00/1K2
R18	0,1 MΩ	A9 999 00/100K	R47	0,39 MΩ	A9 999 00/390E
R19	10 MΩ	A9 999 00/10M	R60	100 Ω	A9 999 00/100E
R20	0,47 MΩ	A9 999 00/470K			
R21	0,22 MΩ	A9 999 00/220K			
R22	47.000 Ω	A9 999 00/47K			
R23	1.000 Ω	A9 999 00/1K			

* afregelen op 56 pF
 adjust for 56 pF
 régler à 56 pF
 ajústese a 56 pF

B5 X 65 A

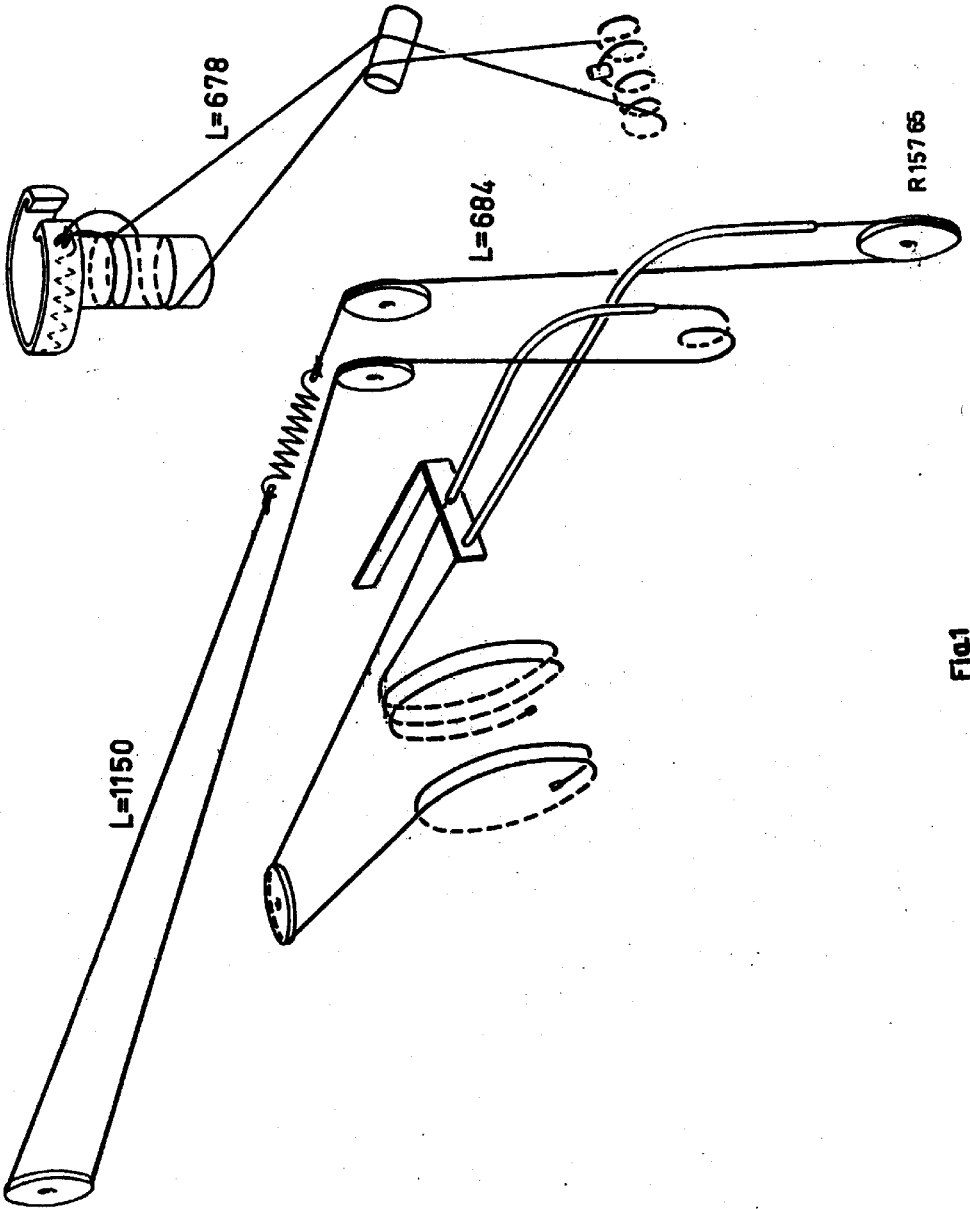
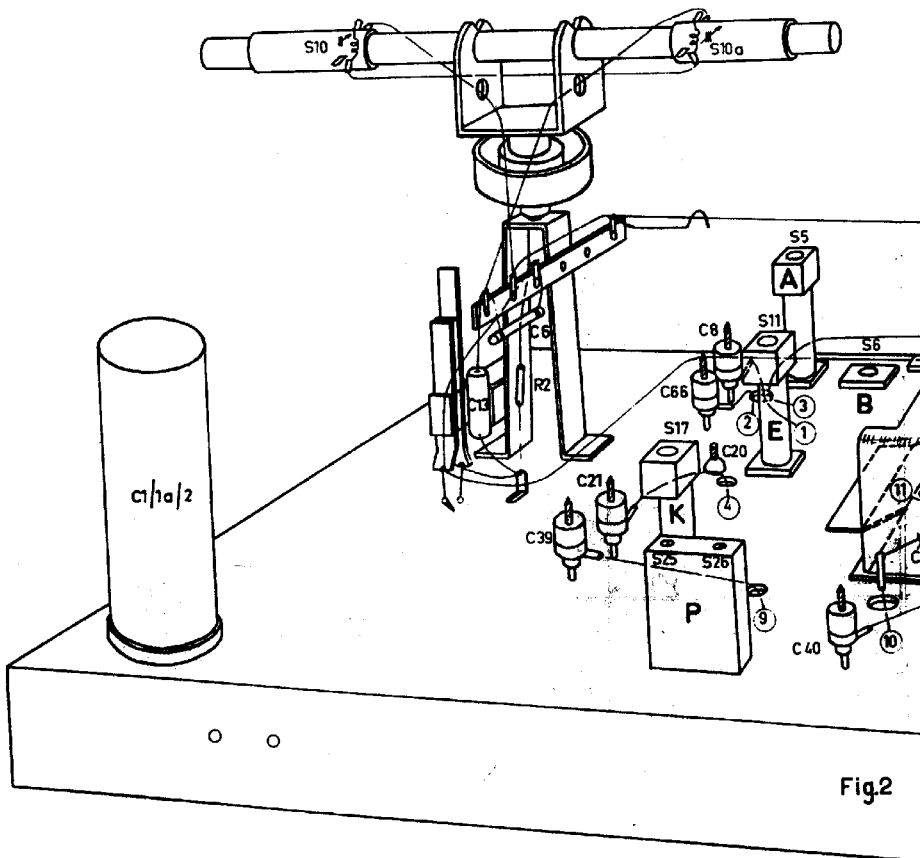
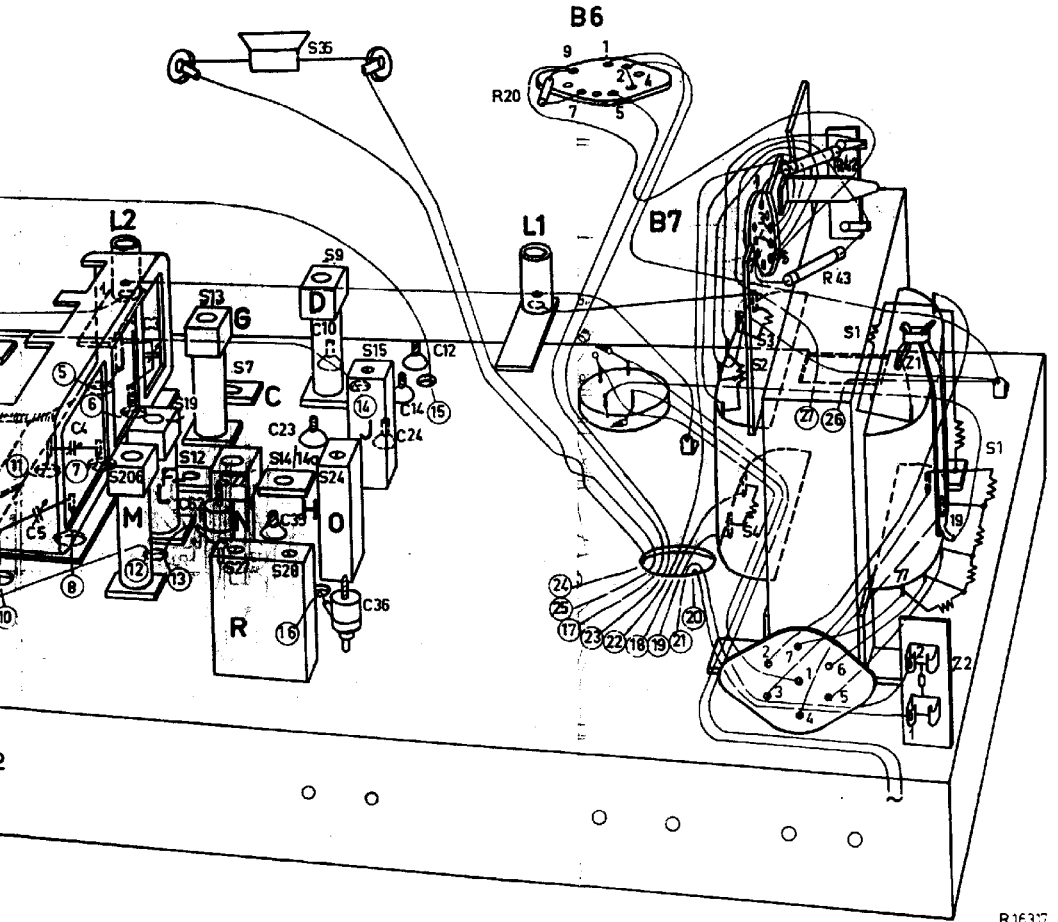

Fig. 1





S	31.30										J O R			D H N			C G									
C	55	48	47	49	56	57	54	70	46	59	53	52	51	63	33	12	14	24	22	10	60	23	35	15	65	67
R	47	29	31	30	15	17	16	30	25	14	33	23	41	28	37	21	19	22	13	18	35	36	34	26	12	

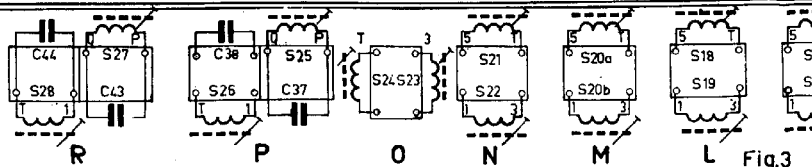
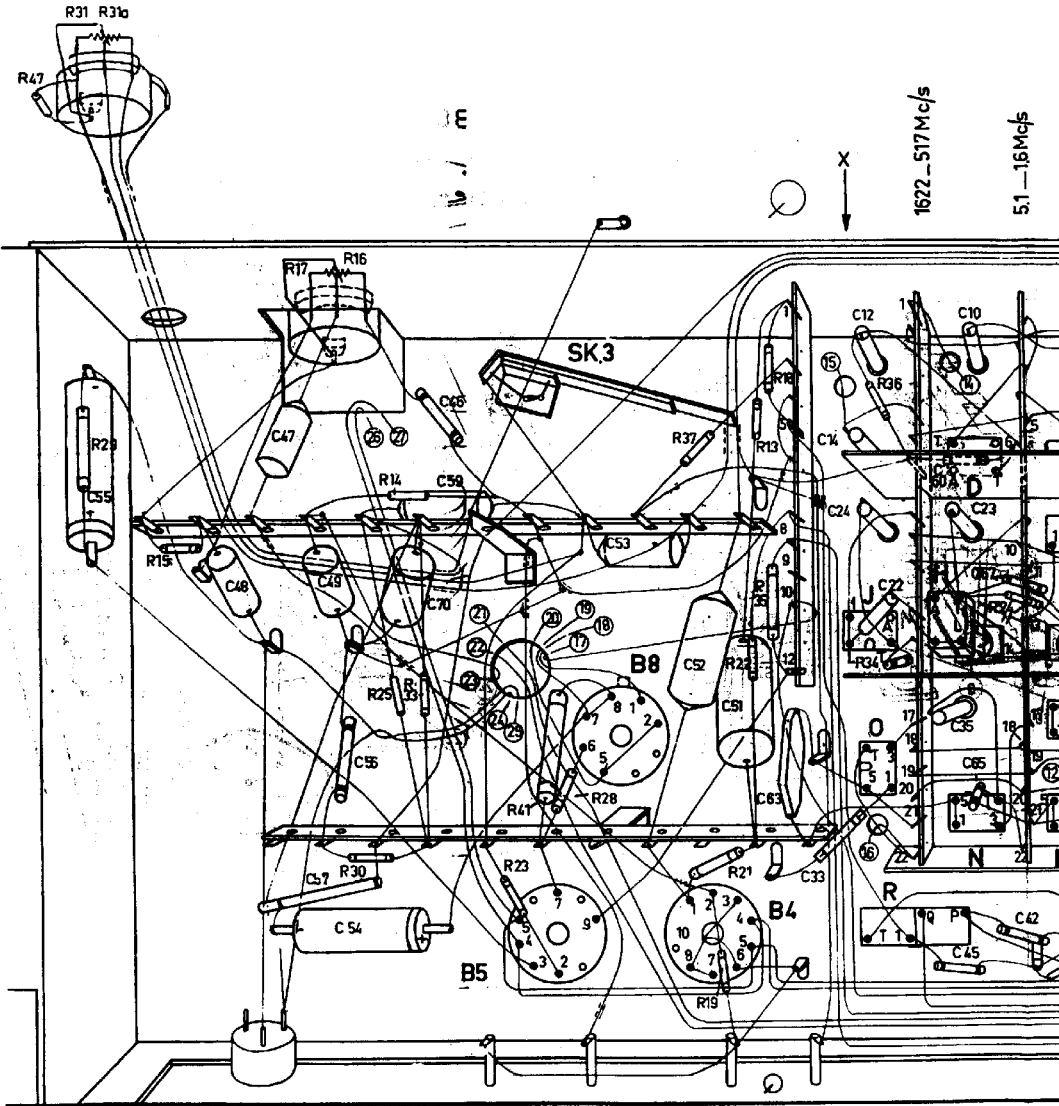
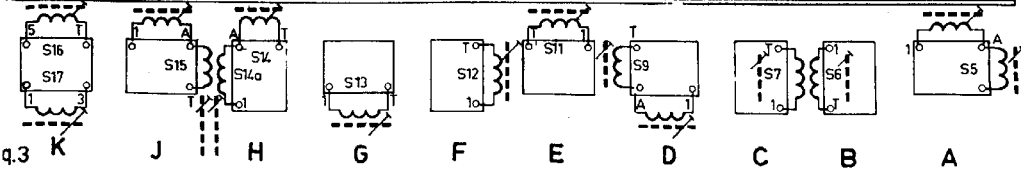
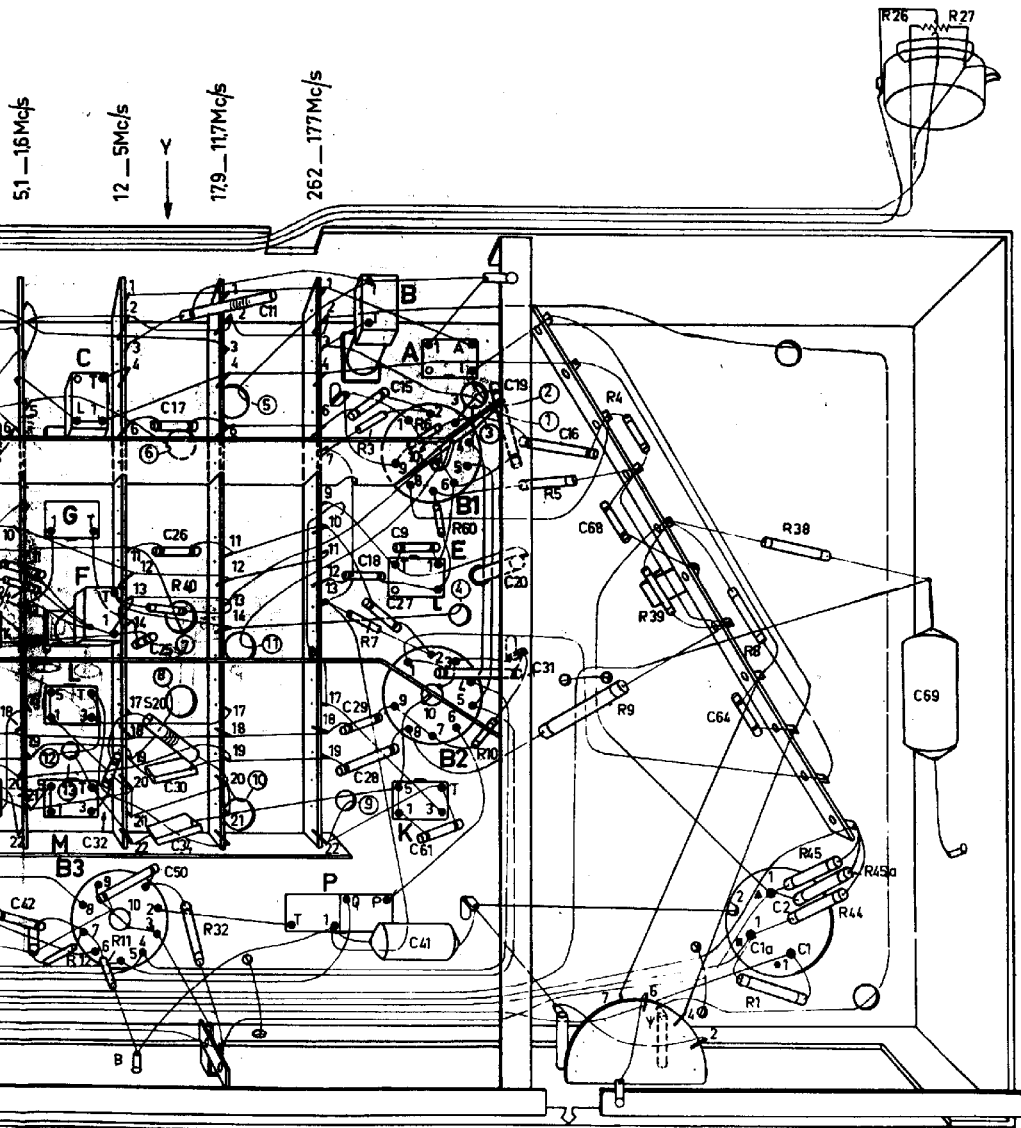

Fig.3

C	G	F	L	M	20.	P	B	E	K	A												
15	16	56	742.	32	50	25	17	26	30	34	11.											
24.	12.	11.	40.	32.	3.	7.	6.	60.	10.	5.	9.	4.	39.	8.	1.	38	45	44	45	a.	26.	27.



S: 5	629.10.10a.															11-45					16-24.					25																			
C:	66	64	7	60	13	10	12	8	11	14	17	4	15	16	19	68	18	9	67	25	24	20	21	22	23	26	27	5	27	31	28	30	6	29	32	63	33	39	40	62	35	36	51	34	65
R:	2.			36			34			6	5.	39			40	24	34			8					7.	8			10.																

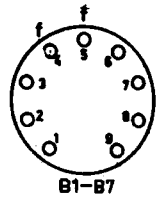
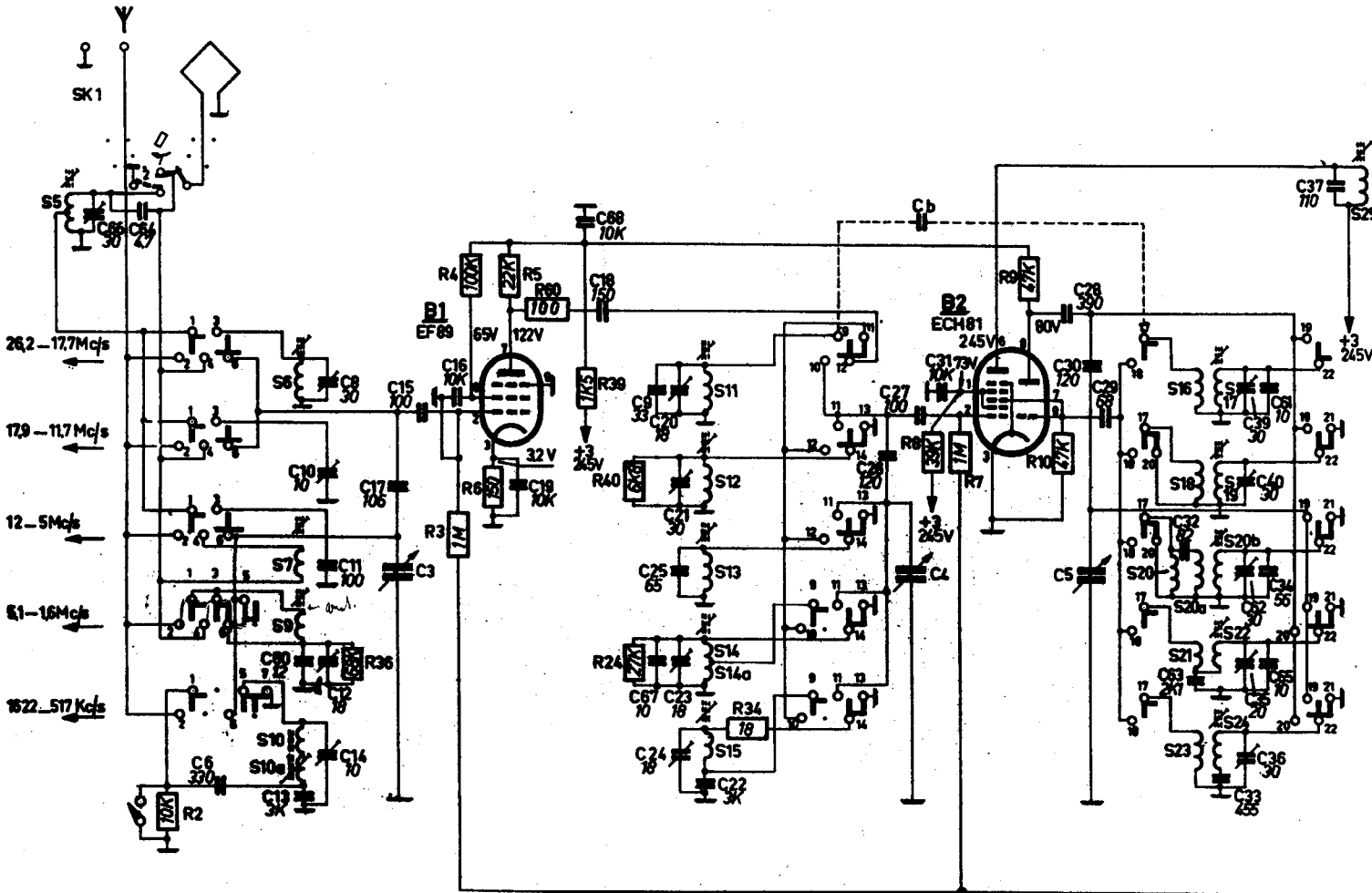
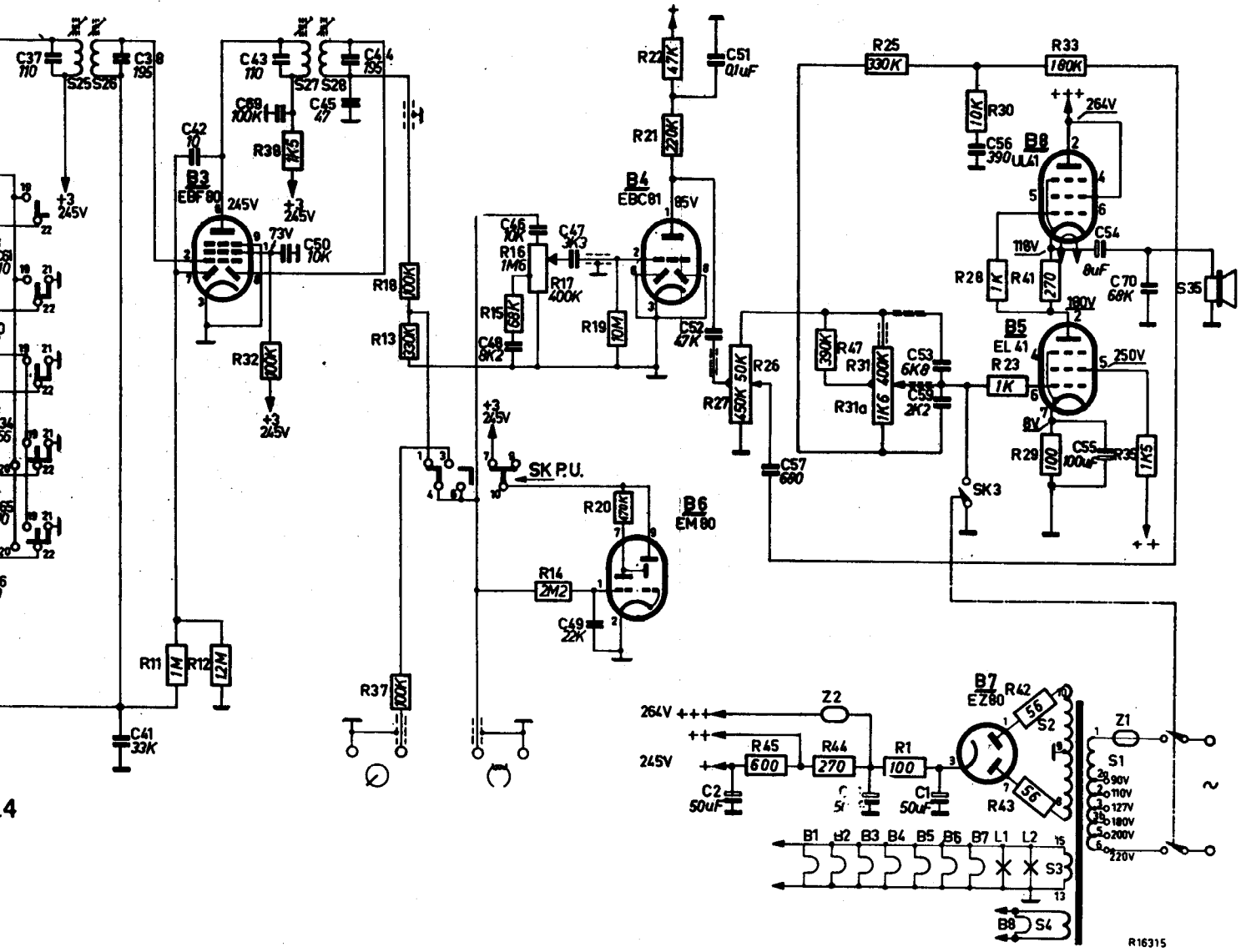

Fig.4

25, 26	27, 28								4	35
2, 3, 36, 61, 34, 65, 37, 38, 41	42	68, 43, 50	45, 44	48	46	47, 49	52, 2, 51, 57	1a	53, 1, 59, 56	54, 55, 70
	11, 12	32, 38	37, 18, 13	15	16, 17, 14	19, 20	21, 22	26, 27, 45	47, 31, 31a, 44, 25	1, 30, 28, 23, 41, 42, 43, 29, 33



R16315