

WESTINGHOUSE ELECTRIC CORP.

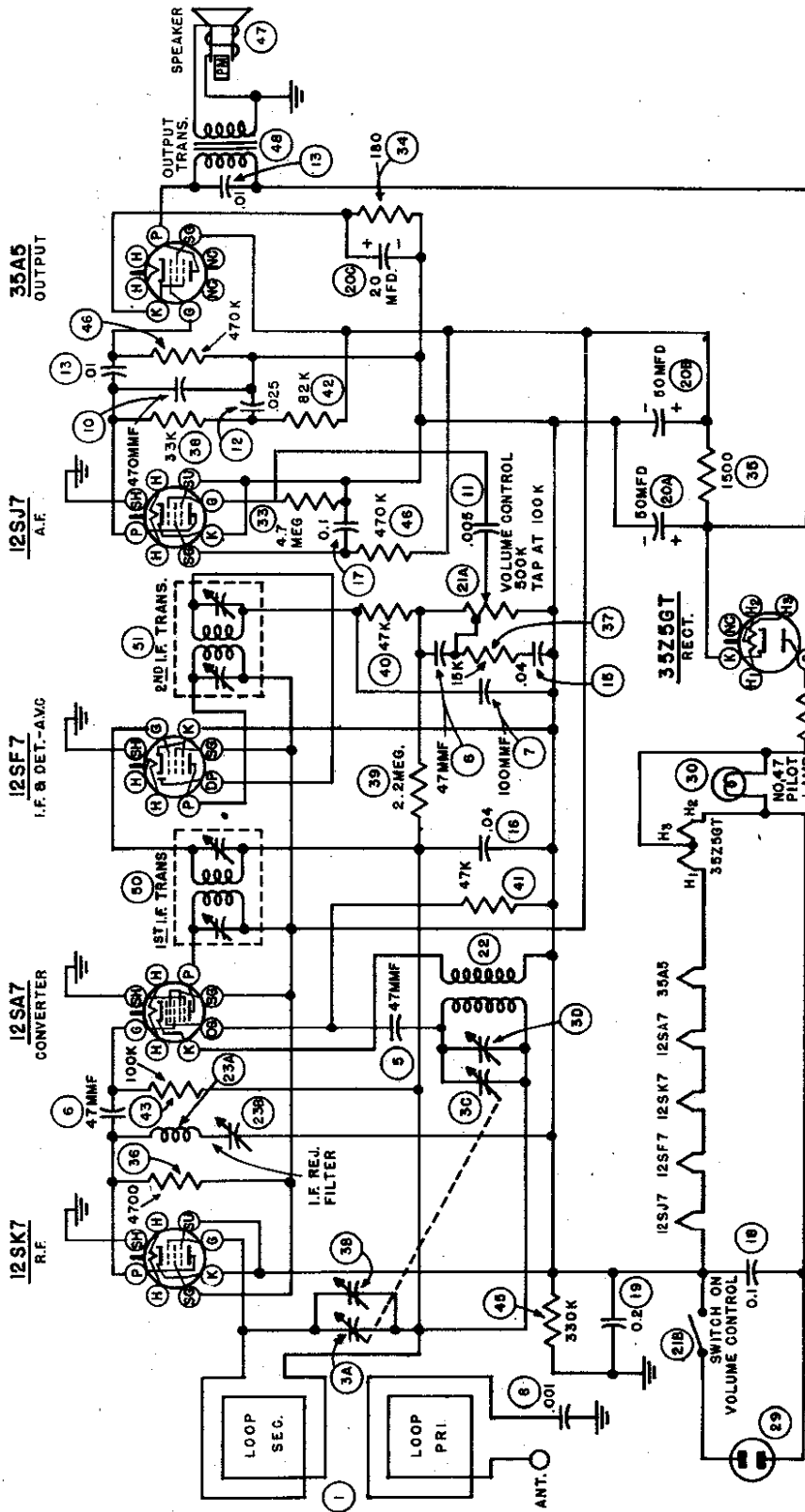

RESISTANCE TABLE

| ITEM | PRIMARY OHMS | SECONDARY OHMS | REMARKS |
|------|--------------|----------------|-------------------------|
| 1 | | 2 | |
| 22 | 1/2 | 7 | |
| 23A | 50 | | |
| 50 | 27 | 26 | |
| 51 | 27 | 23 | |
| 47 | | 2.95 | VOICE COIL DISCONNECTED |
| 48 | 375 | 1/4 | VOICE COIL DISCONNECTED |

INTERMEDIATE FREQUENCY : 455 KC

VOLTAGE AND CURRENT TABLE
 ALL VOLTAGES ARE MEASURED FROM THE NEGATIVE SIDE OF THE DUAL FILTER CAPACITOR USING A 20,000 OHMS PER VOLT METER. LINE VOLTAGE IS 117 V. A.C. SIGNAL VOLTAGE IS ZERO.

| TUBE | SOCKET TERMINAL | | |
|--------|-----------------|-----|------|
| | K | 50 | P |
| 12SK7 | ZERO | 70 | 31 |
| 12SA7 | ZERO | .70 | 69 |
| 12SF7 | ZERO | 70 | 69 |
| 12SJ7 | ZERO | 19 | 26 |
| 35A5 | 4.25 | 70 | 115 |
| 35Z5GT | 122 | | 52.0 |

READINGS SHOULD APPROXIMATE THE ABOVE WITHIN 20 PERCENT.

Loudspeaker:

Type 5" dia. P.M. dynamic
 V.C. Impedance 3.2 ohms at 400 cps

Power Output:

Undistorted 0.85 watt
 Maximum 1.25 watts

WESTINGHOUSE ELECTRIC CORP.

to 1615 kc. Tune the receiver tuning condenser to minimum. Adjust the trimmer on the oscillator section of the main tuning condenser for **maximum** reading on the output meter.

12. Adjust the signal generator to 1400 kc. Bring the output lead near the receiver input but do not make an actual connection. Tune in the test signal on the receiver dial and adjust the antenna trimmer for maximum output as read on the output meter.

The foregoing alignment procedure is condensed in the following table as a convenience for the service technician:

| Steps | Connect Signal Generator to— | Adjust Signal Generator to— | Tune Radio Dial to— | Adjust for Maximum Output |
|-------|--|-----------------------------|---------------------------|---|
| 1 | 12SF7 grid in series with a .01 mfd. capacitor | 455 kc | quiet point near 1600 kc. | primary and secondary 2nd i-f transformer |
| 2 | 12SA7 grid in series with a .01 mfd. capacitor | 455 kc | quiet point near 1600 kc. | primary and secondary 1st i-f transformer |
| 3 | 12SA7 grid in series with a .01 mfd. capacitor | 455 kc | quiet point near 1600 kc. | repeat 1 and 2 |
| 4 | antenna terminal | 455 kc | 600 kc | adjust i-f rejection trimmer for minimum output |
| 5 | antenna terminal in series with a 50 mmfd. capacitor | 1615 kc | gang at minimum | oscillator trimmer |
| 6 | radiated signal from signal generator | 1400 kc | 1400 kc | adjust antenna trimmer |

Power Supply Polarity:

When the receiver is operated on 110 volts 60 cycles a.c., a slight hum may be heard if the power plug is inserted in such a manner that the "hot" side of the supply line is connected nearest to the chassis. To eliminate this trouble, reverse the supply plug in the convenience outlet.

When operated on direct current, the set will not function at all if the power plug polarity is reversed with respect to the line voltage. If it does not operate within one minute after it is turned on, reverse the plug in the convenience outlet.

Tube Replacement:

When replacing tubes this procedure must be followed to prevent damage to the loop and other delicate parts:

1. Disconnect the power plug from the 110-volt service outlet.
2. Pull the knobs and remove the Phillips-head screw from the right-hand plastic cover.
3. Carefully remove the plastic cover and handle.
4. Lift the loop assembly and tilt it forward until the tubes are accessible.
5. Turn the tuning dial to 550 kc to avoid damage to the rotor plates of the tuning condenser.

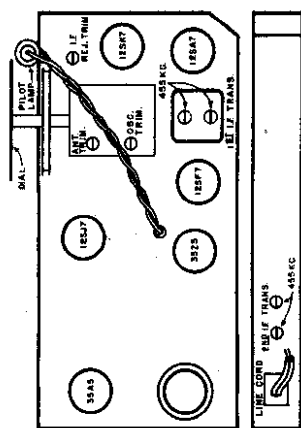

Fig. 1

Alignment Procedure (Refer to Fig. 1):

The overall sensitivity and selectivity of the Little Jewel are affected to a great extent by the alignment of the i-f and r-f circuits. In general, a complete realignment of both circuits is unnecessary. If realignment is required, however, the following procedure is recommended:

1. Remove the knobs, the plastic cover, and the loop as outlined above.
2. Remove the Allen head screw from the left-hand plastic cover and carefully lift off the cover.
3. Turn on the receiver and tune to a quiet spot near 1600 kc.
4. Connect an a-c output meter across the speaker voice coil. Turn the meter range switch to a high-voltage position.
5. Connect the outer conductor of the signal generator test lead to the common negative (this is the metal can enclosing the filter capacitors). Reduce the output of the signal generator to prevent a.v.c. action during the alignment procedure.
6. Connect the inner conductor of the signal generator test lead to the 12SF7 i-f amplifier control grid through a capacitance of 0.01 mfd. Adjust the signal generator frequency to 455 kc.
7. With an insulated screwdriver or neutralizing tool, adjust the second i-f transformer **secondary** trimmer for maximum reading on the output meter. Use the lowest practicable scale on the meter and, as the circuits come into alignment, reduce the signal generator output to prevent a.v.c. action.
8. Repeat operation 7, this time adjusting the second i-f transformer **primary** trimmer.
9. Connect the signal generator output, through the 0.01 mfd. capacitor, to the control grid of the 12SA7 converter tube. Repeat operations 7 and 8, this time adjusting the secondary and primary trimmers of the **first** i-f transformer.
10. Connect the signal generator output, adjusted to 455 kc, to the antenna terminal at the bottom of the cabinet. Tune the radio dial to 600 kc. Adjust the i-f rejection trimmer for **minimum** reading on the output meter.
11. Connect the test oscillator output through a capacitance of 50 mmfd. to the antenna terminal at the bottom of the cabinet. Adjust the signal generator frequency

WESTINGHOUSE ELECTRIC CORP.

PARTS LIST FOR H-125 AND H-126

When ordering parts specify model number of set in addition to part number and description of part.

| Item No. | Part No. | Description of Part |
|----------|--------------------------|---|
| 1 | V-3466 | Loop antenna |
| 3 | V-3474 | Capacitor, variable |
| 3A | RCPIOW6102A | Capacitor, antenna tuner |
| 3B | RCPIOW2253K | Capacitor, antenna trimmer |
| 3C | RCPIOW2103A | Capacitor, oscillator tuner |
| 3D | RCPIOW2403K | Capacitor, oscillator trimmer |
| 5 | RCM20A470M | Capacitor, 47 mmfd. |
| 6 | RCM20A101M | Capacitor, 100 mmfd. |
| 7 | RCP10W6102A | Capacitor, 1,000 mmfd. |
| 8 | RCP10W471M | Capacitor, 470 mmfd. |
| 11 | RCP10W6502A | Capacitor, .005 mfd. |
| 12 | RCP10W2253K | Capacitor, .025 mfd. |
| 13 | RCP10W2103A | Capacitor, .01 mfd. |
| 15 | RCP10W2403K | Capacitor, .04 mfd. |
| 16 | RCP10W2403A | Capacitor, .04 mfd. |
| 17 | RCP10W2104A | Capacitor, .10 mfd. |
| 18 | RCP10W4104A | Capacitor, .10 mfd. |
| 19 | RCP10W2204A | Capacitor, .20 mfd. |
| 20 | V-3470 | Capacitor, electrolytic |
| 20A | Part of Item 20 | Capacitor, 50 mfd. 150 volts electrolytic |
| 20B | Part of Item 20 | Capacitor, 50 mfd. 150 volts electrolytic |
| 20C | Part of Item 20 | Capacitor, 20 mfd. 25 volts electrolytic |
| 21 | V-3476 | Control, volume and switch |
| 21A | Part of Item 21 | Control, variable resistor |
| 21B | Part of Item 21 | Control, switch |
| 22 | V-3473 | Coil, oscillator |
| 23 | V-3465 | Coil, trap assembly |
| 23A | Part of Item 23 | Coil |
| 23B | Part of Item 23 | Trap trimmer |
| 29 | V-3477 | Cord, power A.C. |
| 30 | Westinghouse Type No. 47 | Light, pilot |
| 31 | RC20AE270K | Resistor, 27 ohms 0.5 watt |
| 33 | RC20AE475M | Resistor, 47 megohms 0.5 watt |
| 34 | RC20AE181J | Resistor, 180 ohms 0.5 watt |
| 35 | RC30AE152K | Resistor, 1,500 ohms 1 watt |
| 36 | RC20AE472K | Resistor, 4,700 ohms 0.5 watt |
| 37 | RC20AE153K | Resistor, 15,000 ohms 0.5 watt |
| 38 | RC20AE333K | Resistor, 33,000 ohms 0.5 watt |
| 39 | RC20AE225M | Resistor, 2.2 megohms 0.5 watt |
| 40 | RC20AE473M | Resistor, 47,000 ohms 0.5 watt |
| 41 | RC20AE473K | Resistor, 47,000 ohms 0.5 watt |
| 42 | RC20AE823K | Resistor, 82,000 ohms 0.5 watt |
| 43 | RC20AE104K | Resistor, 100,000 ohms 0.5 watt |
| 45 | RC20AE334M | Resistor, 330,000 ohms 0.5 watt |
| 46 | RC20AE474K | Resistor, 470,000 ohms 0.5 watt |
| 47 | V-3475 | Speaker, 5 inch permanent magnet |
| 48 | V-3496 | Transformer, output |
| 50 | V-3471 | Transformer, 1st i-f |
| 51 | V-3472 | Transformer, 2nd i-f |
| | V-3219S-1 | Cord, dial drive |

| | |
|-----------|--|
| V-3455-1 | Dial (for Model H-125 only) |
| V-3455-2 | Dial (for Model H-126 only) |
| V-3449 | Drive shaft bearing |
| V-3480 | Shaft, drive |
| V-3468 | Socket, molded octal tube |
| V-3469 | Socket, molded octal tube (shielded) |
| V-3499 | Socket, pilot light |
| V-3448 | Spring, dial drive |
| V-3435 | Bumper, felt (screw type) |
| V-3501-1 | Case assembly, center |
| V-3461-1 | Cover, left-hand (H-125 only) |
| V-3459-1 | Cover, right-hand (H-125 only) |
| V-3498-1 | Handle assembly (H-125 only) |
| V-3481-1 | Knob (H-125 only) |
| V-3491 | Terminal strip assembly |
| V-3461-2 | Cover, left-hand (H-126 only) |
| V-3459-2 | Cover, right-hand (H-126 only) |
| V-3498-2 | Handle assembly (H-126 only) |
| V-3481-2 | Knob (H-126 only) |
| V-3711-1 | Baffle and Grille Cloth Assembly (H-125) |
| V-3711-2 | Baffle and Grille Cloth Assembly (H-126) |
| V-3338S-1 | Medallion (H-125 only) |
| V-3338S-2 | Medallion (H-126 only) |
| V-3745 | Socket, lock-in |

SUBJECT: CIRCUIT CHANGE, H-125 and H-126 Radios

Effective July 11, 1946, all Model H-125 and H-126 radios which have the letter "Ch" stamped on the end of the chassis directly below the output tube, have been changed as follows:

A 470 ohm 1/4 watt isolating resistor has been inserted in the plate and screen supply line for the R.F. and converter stages, and a .02 mfd, 200 volt paper by-pass capacitor has been connected from the tube side of this resistor to the common negative line. These connections are shown below.

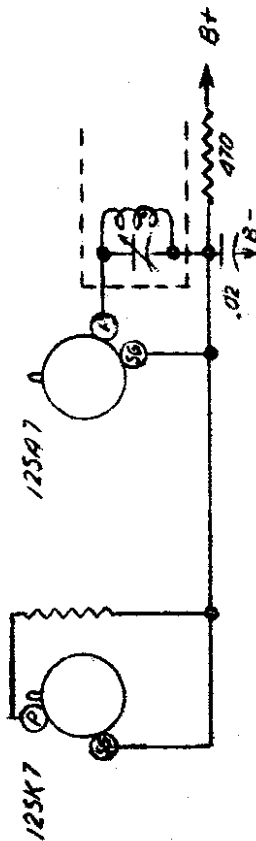

Where this change has been incorporated in the radio, voltages at the R.F. and converter tube sockets will differ slightly from the values given in the original Service Notes. Approximate voltages when the change is incorporated are as follows: 125K7 screen grid 66 V., plate 30 V.; 125A7 screen grid 65 V., plate 65 V.

Procurement difficulties with respect to certain components make the change advisable at this time.

Tele-Tone Chassis A

Models 123, 125, 127, and 131 are the same as Model 100, Chassis A, which appears on page 15-2 of *Rider's Volume XV*.

Tele-Tone Chassis D

Models 110, 119, 124, 126, and 132 are the same as Model 117, Chassis D, appearing in *Rider's Volume XV*, page 15-4.

Tele-Tone Chassis U

Models 172 and 176 are the same as Model 156, Chassis U, which appears on page 17-4 of *Rider's Volume XVII*.

Tele-Tone Chassis W

Models 154, 155, 173, and 177 are the same as Model 152, Chassis W, which appears on pages 17-2 and 17-3 of *Rider's Volume XVII*.

Templetone H-127

This model is the same as Model G-725, appearing on pages 17-3 through 17-6 of *Rider's Volume XVII*.

United Motors 982421

This model appears on pages 19-44 through 19-49 of *Rider's Manual Volume XIX*. The following service parts have been changed after serial #1-38500.

| Illus. No. | Production Part No. | Service Part No. | Description |
|------------|---------------------|------------------|-------------------------------|
| 6 | 1219508 | 1219508 | 1st i-f coil assy. |
| 7 | 1219509 | 1219509 | 2nd i-f coil assy. |
| 25 | 7240724 | M908 | Electrolytic |
| 25A | | | 20 μ f, 25 v. |
| 25B | | | 20 μ f, 400 v. |
| 25C | | | 20 μ f, 400 v. |
| 28 | 7237836 | E202 | 0.002 μ f, 600 v. tubular |
| 48 | 1213217 | A101 | 100 ohms, 1/2 w. |
| | 1218107 | 5233 | 6SR7 |
| | 1213793 | 5241 | 6V6GT |
| | 7237751 | 5229 | 6SK7 |
| | 7237752 | 5222 | 6SA7 |

Watterson RC-4581

This model is the same as Model 4581 appearing on page 15-1 of *Rider's Volume XV*.

Western Auto D2718 Series B, Serial No. 137000 Up

This model is the same as Model D2718, appearing on pages 17-20 through 17-23 of *Rider's Volume XVII*, except for the following changes. Capacitor C30, formerly connected from the junction of R-16, C-29, and pin 8 of the 12SQ7 tube to pin 2 of the 35Z5GT rectifier tube, is connected from the same junction to the center tap (pin 3) of the filament of the 35Z5GT rectifier tube.

The part number of capacitor C16 and C20 should be changed from 47X446 to 47X466. The value remains the same. Part number 17X96, celluloid crystal, should be added to the parts list.

Western Auto D4832-B

This model appears on pages 18-69 through 18-72 of *Rider's Volume XVIII*. The "B" chassis of this model differ from the "A" chassis by a change in the value of resistor R-4 from 220,000 ohms to 10,000 ohms.

The new part number and description are as follows:
R-4 B-85103 10,000 ohms, 0.5 w.

United Motors R-705

This model appears on pages 17-1 through 17-6 of *Rider's Volume XVII*. This receiver may be installed in the 1949 Fords by using parts from the adapter parts package number 4428. It is necessary to use the Delco universal speaker, part number 6111—6" x 9" elliptical speaker, in place of the speaker supplied with the radio set. This speaker should be returned to your stock under part number 6104.

The parts that are to be used from adapter package 4428, are shown in the following operations.

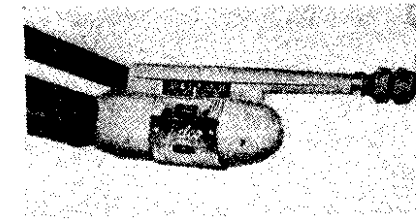
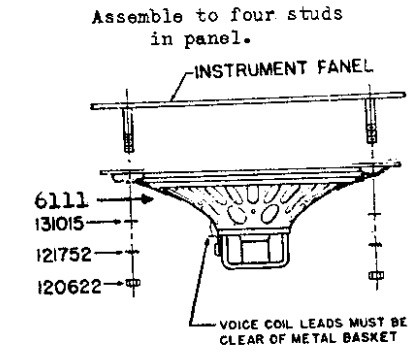
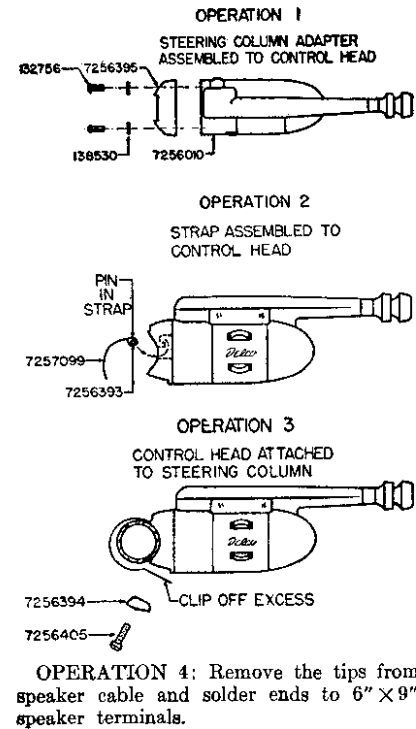

The various operations necessary to install United Motors Model R-705 in the 1949 Fords, as well as the assembled control head are illustrated.

Westinghouse H-125, H-126, H-127

Models H-125 and H-126 appear in *Rider's Volume XV*, pages 15-8 through 16-10. Several changes were made in the chassis of these two models in late production. A 35L6GT output tube replaces the 35A5. The electrical characteristics of the tubes are similar except for a difference in tube bases and connections. An isolating network consisting of a 470-ohm resistor (44) and a 0.02- μ f capacitor (14) has been inserted in the plate and screen voltage supply line for the rf and converter stages. In the circuit, the rotor plates of the tuning and trimmer capacitors are now connected directly to chassis ground rather than to the AVC line.

Model H-127 is the same as the previous models with a burgundy and gold cabinet. The following items should be added to the parts lists for these models:

- 14 RCP10W2203A Capacitor, 0.02 μ f
- 44 RC20AE471M Resistor, 470 ohms 0.5 watt
- V-3711-2 Case Assembly, center (H-126 and H-127)
- V-3991 Cover, left hand (H-127)
- V-3992 Cover, right hand (H-127)
- V-3498-2 Handle Assembly (H-127)
- V-3481-2 Knob (H-127)
- V-3333-2 Medallion (H-127)
- V-3455-2 Dial (H-127)

Westinghouse H-164, H-166, H-166A, H-167

These models appear on pages 18-12 through 18-19 of *Rider's Volume XVIII*.

To reduce hum in later production of these models, a de-coupling network was inserted in the plate circuit of the 6AT6 a-m detector, avc and a-f amplifier tube. This network consists of a 100,000-ohm 1/2 watt resistor (RC20AE104K) and a 0.1 μ f 400 volt resonant type capacitor (V-5442-1). The resistor is inserted between the plate load resistor (R11) and the B plus line, and the capacitor is connected from the junction of R11 and the new resistor to ground.

Westinghouse H-183, H-183A

These models appear on pages 19-15 through 19-17 of *Rider's Manual Volume XIX*. An error exists in the schematic diagram. The value of R9 in the converter circuit should be 3,300 ohms instead of 300 ohms.

The position of C20 in the circuit has been changed. On some chassis this capacitor was connected across the primary of the output transformer as shown on the schematic diagram. In later production, the capacitor is connected from the plates to the cathodes of the parallel 25L6GT output tubes.

Westinghouse H-186, H-187

These models appear on pages 18-26 through 18-30 of *Rider's Volume XVIII*.

To reduce hum in later production of these models, a de-coupling network was inserted in the plate circuit of the 6AT6 AM detector, AVC and A-F amplifier tube. This network consists of a 100,000 ohm 1/2 watt resistor (RC20AE104K) and a 0.05 μ f 400 volt capacitor (RCP10W4503A). The resistor is inserted between the plate load resistor (R13) and the B plus line, and the capacitor is connected from the junction of R13 and the new resistor to ground.