

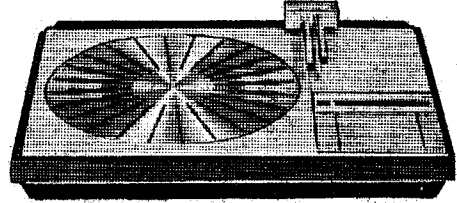

BEOGRAM 4000
TYPE 5215



CONTENTS	SECTION/PAGE
TECHNICAL DATA	1
Diagram explanation	1 - 2
DISASSEMBLY	2
CIRCUIT DIAGRAM, PC-BOARDS AND PARTS LIST	3
Circuit Diagram	3 - 1
Transistor List	3 - 3
Parts List	3 - 4
PC-boards	3 - 5
ADJUSTMENT	4
Mechanical	4 - 1
Adjustment of Turntable	4 - 1
Adjustment of Chassis	4 - 1
Adjustment of Belt Drive	4 - 2
Adjustment of Stroboscope	4 - 2
Adjustment of Slide Contacts	4 - 2
Adjustment of Dial Pointer	4 - 3
Adjustment of Magnet Coil System	4 - 3
Adjustment of Pickup Arm System	4 - 4
Adjustment of Diaphragm	4 - 6
Adjustment of Damper Cylinder	4 - 6
Adjustment of Spindle	4 - 6
Electrical	4 - 7
Adjustment of Speed	4 - 7
Adjustment of Slow Slide Transport	4 - 7
Adjustment of Voltage for Drive Motor	4 - 7
Adjustment of Differential Stop	4 - 8
Lubrication Chart	4 - 8
CHECKING AND FAULT-FINDING DIAGRAMS	5
PARTS LIST	6
SERVICE TIPS	7
Dismounting and mounting of Pushbutton	7 - 1
Dismounting of Slide	7 - 1
Mounting of Cable in the Pickup Arm	7 - 1

TECHNICAL DATA

Motor		BEOGRAM 4000 type 5215
Wow and Flutter	DIN 45 500, Page 3	< ± 0.05 %
	RMS	< ± 0.025 %
Rumble	DIN 45 500, Page 3	A B > 42 dB > 65 dB
Speed Control Range		> 6 %
Motor Speed		315/435 rpm
Motor Suspension Resonant Frequency and Weight		3.5 Hz hor., 5 Hz vert. 4.5 kg

Pick-up		
Frequency Response	DIN 45 500, Page 3	± 5 dB ± 2 dB
Channel Separation	DIN 45 500, Page 3	1000 Hz 500 - 6300 Hz
Channel Matching	DIN 45 500, Page 3	< 1.5 dB
Output Voltage and Load		mV/cm/sec. music average
Intermodulation	DIN 45 500, Page 3	< 1 %
Compliance	Stated value X 10 ⁻⁶ cm/dyn.	30
Stylus		Elliptical naked diamond 5 X 17 μ
Recommended, Stylus Pressure		1 gram
Stylus Pressure Range		0 - 1.5 gram
Maximum Tracking Angle Error	With optimal adjustment	0.04°
Arm Length, Suspension to Stylus		155 mm
Replacement Stylus Assembly		Complete cartridge type 8905428

Other Data		
Power Supply		110, 130, 220, 240 volts 50 - 60 Hz 40 watts
Dimensions		10 X 49 X 38 cm
Weight		12 kg

		BEOGRAM 4000 Type 5215
Speeds		33 - 45 rpm electronic section
Pickup-arm System		Tangential
Pickup Cartridge		SP 15
Automatic Record-size Scanning		Yes
Automatic Pickup-movement Control		Yes
Automatic Speed Selection		Yes
Cueing Control		Electronic air-pressure damped
Skating Compensation		Parallel tracking error angle compensated
Drive System		Belt
Motor		Synchronous electronically controlled
Vernier Speed Adjustment		Yes separately
Motor Suspension System		Leaf springs and pendulums
Turntable, Diameter and Weight		Zinc cast, diameter 300 mm 2.2 kg
Stroboscopic Scale		Light indicator 33 and 45 rpm 50 and 60 Hz
Dust Cover		Transparent, hinged and detachable
Meets DIN 45 500 Requirements		Yes

Subject to change without notice

DIAGRAM EXPLANATION

The electrical circuits are, concerning diagram, divided into two diagrams.

1. Control circuit (logic)
2. Power supply, indicator circuit, speed relais circuit, oscillator, lift circuit, motor control (servo), differential stop, detector circuit, etc.

The abbreviations used in connection with the common cable are the abbreviations of the functions in English. The outputs of the flip-flops are designated Q and \bar{Q}

The stated voltages are positive in relation to chassis. They are measured with the detector arm above the ribs of the turntable with no record on and with a stationary pick-up arm.

ADSKILLELSE

DISASSEMBLY/ZERLEGUNG

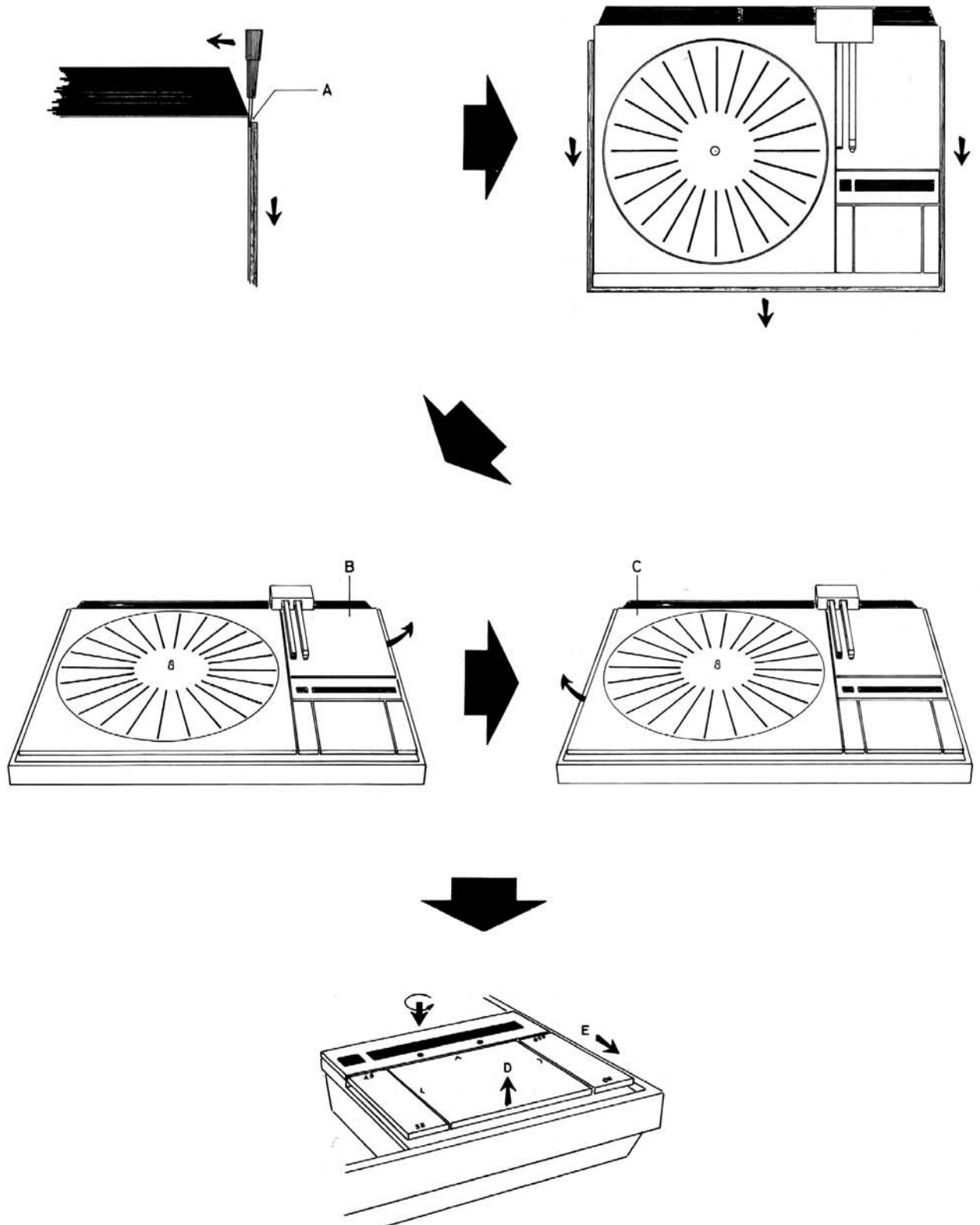
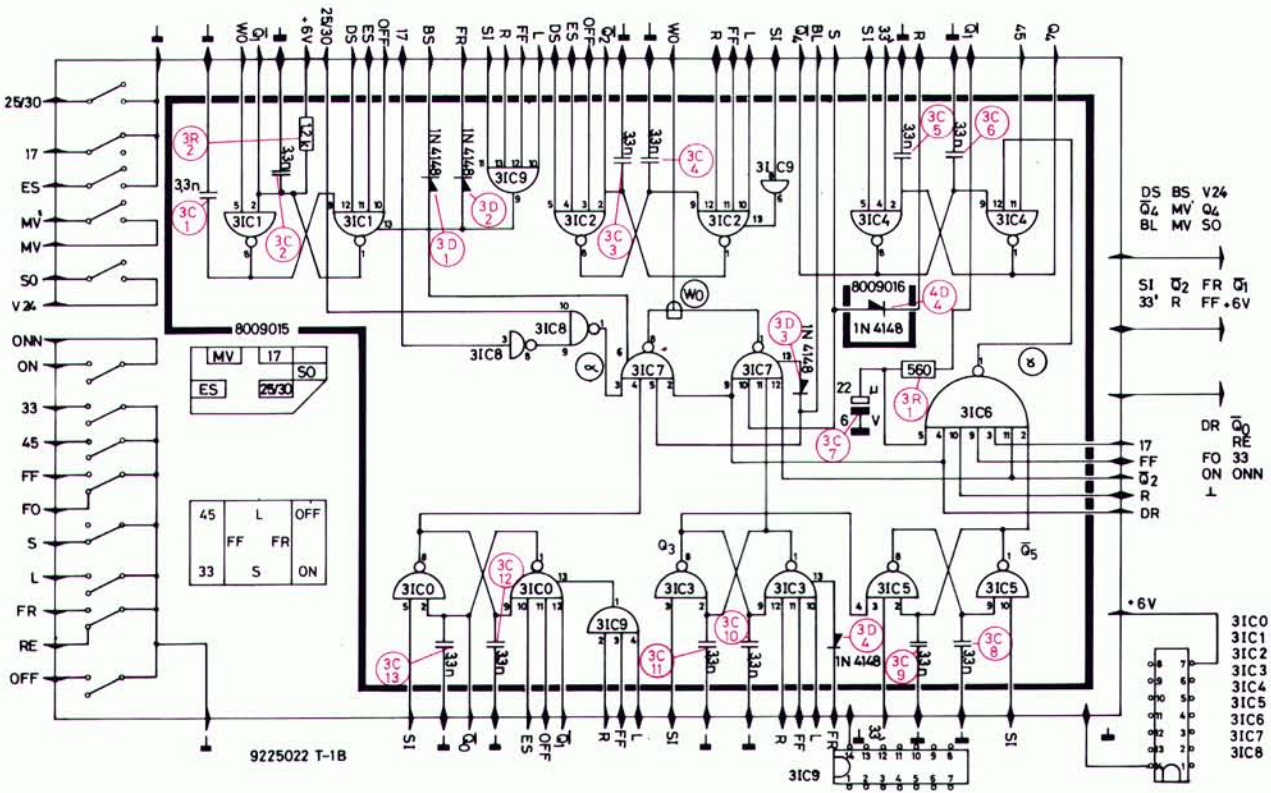





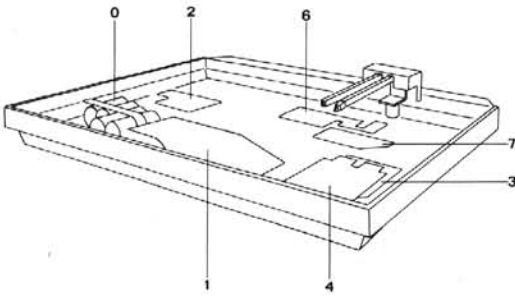

DIAGRAM 1



	INDEX	
3 IC 0	8340013	FCH 131
3 IC 1		
3 IC 2		
3 IC 3		
3 IC 4		
3 IC 5		
3 IC 6	8340012	FCH 111
3 IC 7	8340013	FCH 131
3 IC 8		
3 IC 9	8340011	FCY 101
4 IC 1	8340013	FCH 131

							
1TR1 1TR2 1TR3 1TR4 1TR5	8320095	BC 239 B BC 184 BK	BC 149 B		BC 169 B BC 184 BL	BC 109 B	
1TR6	8320097	BC 237 B BC 182 BK	BC 147 B		BC 167 B BC 182 BL	BC 107 B	
1TR7	8320161	BC 261 B			BC 212 BL	BC 251 B	
1TR8 1TR9	8320232					BC 142 BC 144	
1TR10	8320095	BC 239 B BC 184 BK	BC 149 B		BC 169 B BC 184 BL	BC 109 B	
1TR11	8320232					BC 142 BC 144	
1TR12 1TR13 1TR14 1TR15 1TR16 1TR17	8320095	BC 239 B BC 184 BK	BC 149 B		BC 169 B BC 184 BL	BC 109 B	
1TR18	8320161	BC 261 B			BC 212 BL	BC 251 B	
1TR19 1TR20 1TR21 1TR22	8320095	BC 239 B BC 184 BK	BC 149 B		BC 169 B BC 184 BL	BC 109 B	
1TR23 1TR24	8320161	BC 261 B			BC 212 BL	BC 251 B	
1TR25	8320097	BC 237 B BC 182 BK	BC 147 B		BC 167 B BC 182 BL	BC 107 B	
1TR26	8320161	BC 261 B			BC 212 BL	BC 251 B	
1TR27	8320097	BC 237 B BC 182 BK	BC 147 B		BC 167 B BC 182 BL	BC 107 B	
1TR28/ 1TR29 1TR30/ 1TR31	8320135					BC 143/ BC 144 BC 143/ BC 142	
1TR32	8320161	BC 261 B			BC 212 BL	BC 251 B	
1TR33 1TR34 2TR1 2TR2 2TR3 2TR4 2TR5	8320097	BC 237 B BC 182 BK	BC 147 B		BC 547B BC 167 B BC 182 BL	BC 107 B	
2TR6	8320124					BC 119	
2TR7	8320097	BC 237 B BC 182 BK	BC 147 B		BC 167 B BC 182 BL	BC 107 B	
0TR1	8320103						2 N 5034
0TR2	8320266			TIP 31			
0TR3	8320265			TIP 32			
0TR4	8320312			TIP 41 A			



7 PC 8009010

Pos.	Plac.		Index
		R	
7R1	A1	8,2, TE, 5 %, 1 W	5100082

0

Pos.		Index
	R	
0R1	680, 5 %, 1 W	5012011
0R2	27k, 10 %, 1/2 W	5001047
0R3	ORP 61	5210004
0R4	ORP 61	5210004

C

0C1	2000 μ , 15 V	4200265
0C2	2000 μ , 15 V	4200265
0C3	3000 μ , 50 V	4200258
0C4	3000 μ , 50 V	4200258
0C5	47 n, 10 %, 250 V	4130087
0C6	4000 μ , 25 V	4200259
0C7	150 μ , 10 VRMS, BIPOLAR	4200260

D

0D1	B80C2200	8310020
0D2	24 V, 5 %, 1,3 W	8300160

TR

0TR1		8320103
0TR2		8320266
0TR3		8320265
0TR4		8320312

IL

0IL1	6 V, 30 mA	8230025
0IL2	6 V, 50 mA	8230020
0IL3	GL 90	8230038

M

0M1	6 V, AC	8400015
0M2	12 V, DC	8400014

MS

0MS1		6810001
------	--	---------

PH

0PH1	BP 100	8760002
------	--------	---------

Pos.	25/30	17	ES	MV	SO
1	3152068	3152068	3152068	3152068	3152068
2		2812041			
3	7500060	7500067	7500060	7500060	7500060
4		2364024			
5	7500051	7500051	7500051	7500051	7500051
6	7500050		7500050	7500050	7500050

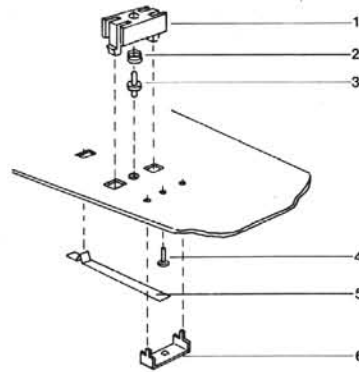

4 PC 8009016

Pos.	Plac.		Index
		R	
4R 1	C2	12 k, 5 %, 1/8 W	5010046
		VR	
4VR1	B3	1 k, LIN, 0,15 W	5300079
4VR2	C3	1 k, LIN, 0,15 W	5300079
		D	
4D 1	B2	1N4148, SFD 184	8300058
4D 2	B2	1N4148, SFD 184	8300058
4D 3	A1	1N4148, SFD 184	8300058
4D 4	B1	1N4148, SFD 184	8300058
		IC	
4IC1	B2	FCH131	8340013

Pos.	33	FF	45	S	L	ON	FR	OFF
1	3152068	3152068	3152068	3152068	3152068	3152068	3152068	3152068
2								
3	7500059	7500066	7500059	7500059	7500059	7500059	7500066	7500059
4		2364024		2364024			2364024	
5	7500051	7500051	7500051	7500051	7500051	7500051	7500051	7500051
6	7500061	7500050	7500061		7500061	7500061	7500050	7500061

BEOGRAM 4000, TYPE 5215

Correct on page 3-4

NB! Correct on pushbutton system
see page 6-4

7 PC 8009010

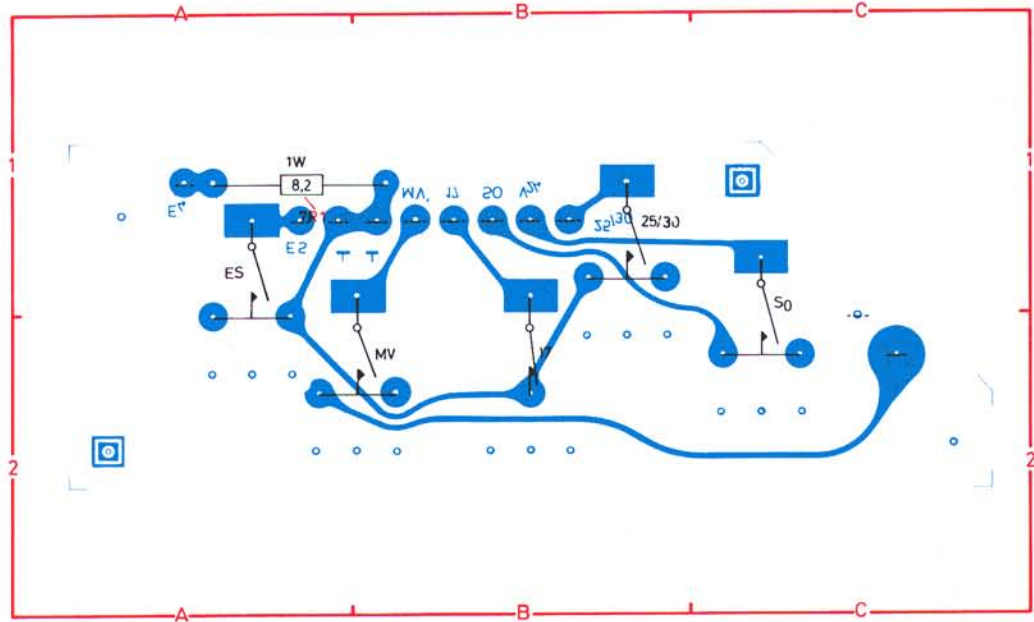

4 PC 8009016

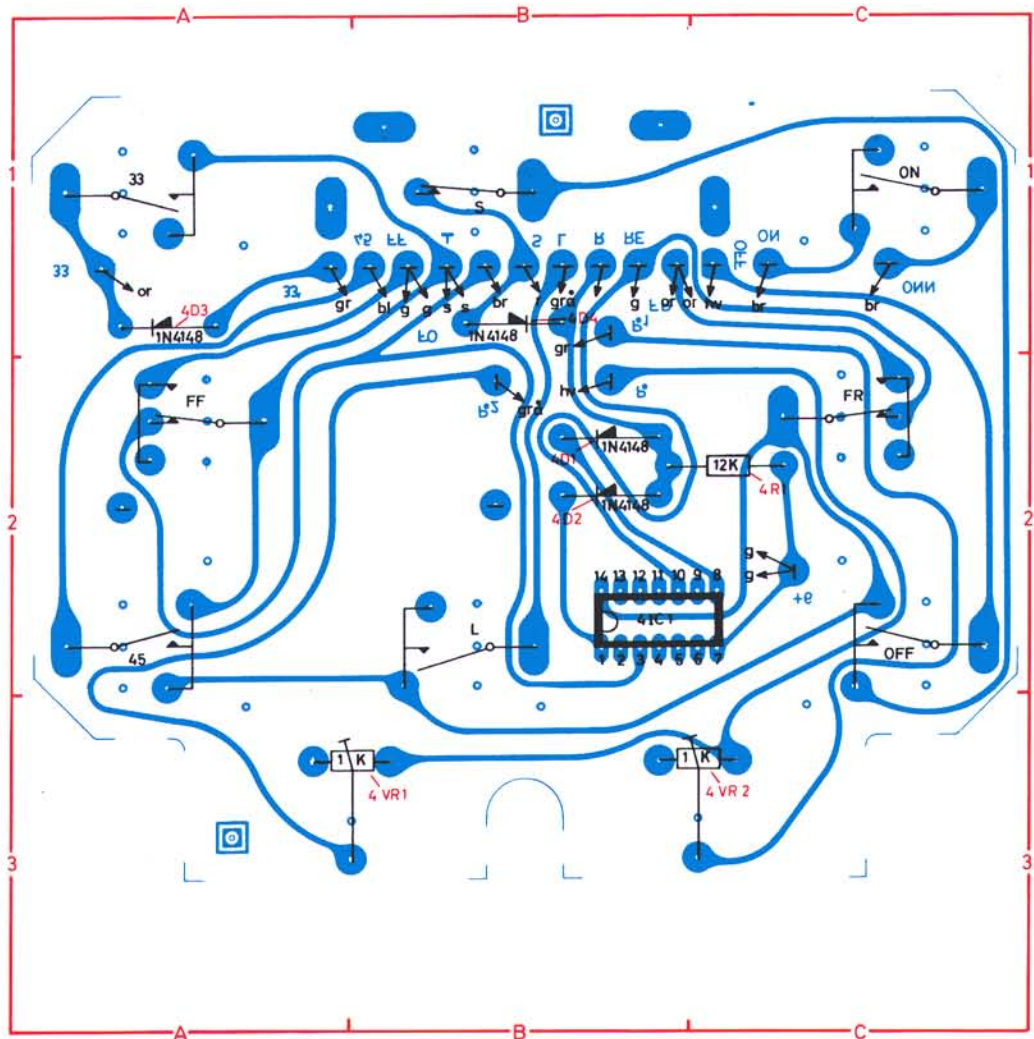

1 PC 8009012

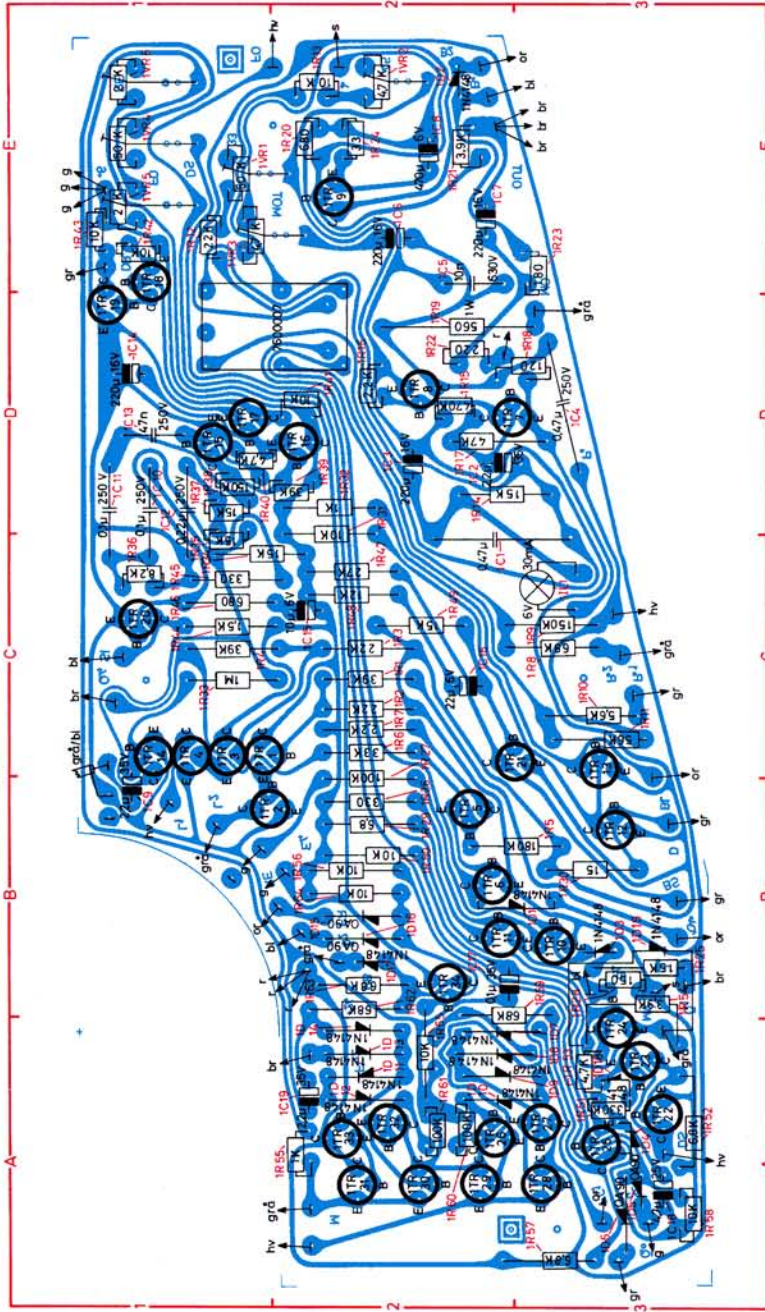

ITR11	B2	8320232
ITR12	B3	8320095
ITR13	C3	8320095
ITR14	C1	8320095
ITR15	D1	8320095
ITR16	D2	8320095
ITR17	D1	8320095
ITR18	E1	8320161
ITR19	E1	8320095
ITR20	C1	8320095
ITR21	C2	8320095
ITR22	A3	8320095
ITR23	A3	8320161
ITR24	A3	8320161
ITR25	A2	8320097
ITR26	A2	8320161
ITR27	A3	8320097
ITR28	A3	8320135
ITR29	A2	8320135
ITR30	A2	8320135
ITR31	A2	8320161
ITR32	A2	8320097
ITR33	A2	8320097
ITR34	B2	8320097

2 PC 8009011

Pos.	Plac.	R	Index
2R 1	B2	1.5 M, 10%, 1/8 W	5010093
2R 2	B2	100 k, 5%, 1/8 W	5010049
2R 3	B2	39 k, 5%, 1/8 W	5010060
2R 4	B2	100 k, 5%, 1/8 W	5010049
2R 5	B2	10 k, 5%, 1/8 W	5010059
2R 6	B1	270 k, 5%, 1/8 W	5010083
2R 7	B1	39 k, 5%, 1/8 W	5010060
2R 8	B2	27 k, 5%, 1/8 W	5010141
2R 9	A2	5.6 k, 5%, 1/8 W	5010041
2R 10	A2	33 k, 5%, 1/8 W	5010075
2R 11	B2	3.9 k, 5%, 1/8 W	5010069
2R 12	A2	220, 5%, 1/8 W	5010092
2R 13	B2	3.9 k, 5%, 1/8 W	5010069
2R 14	B2	15 k, 5%, 1/8 W	5010053
2R 15	B2	5.6 k, 5%, 1/8 W	5010041
2R 16	A2	8.2 k, 5%, 1/8 W	5010154
2R 17	A2	3.9 k, 5%, 1/8 W	5010069
2R 18	A1	390, 5%, 1/8 W	5010070
2R 19	B1	22 k, 5%, 1/8 W	5010079
2R 20	B1	12 k, 5%, 1/8 W	5010046
2R 21	B1	39 k, 5%, 1/8 W	5010060
2R 22	B1	120, 5%, 1/8 W	5010128

2 PC 8009011

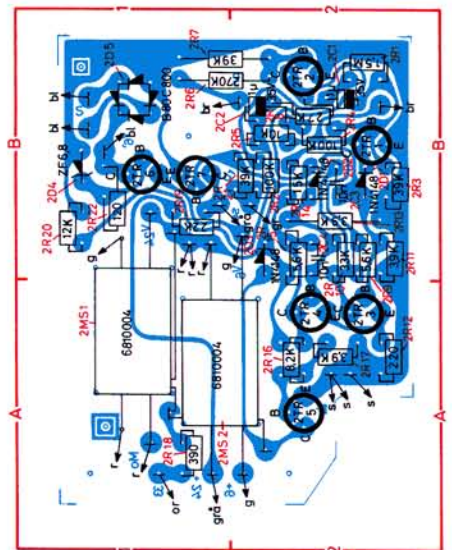

6 PC 8009019

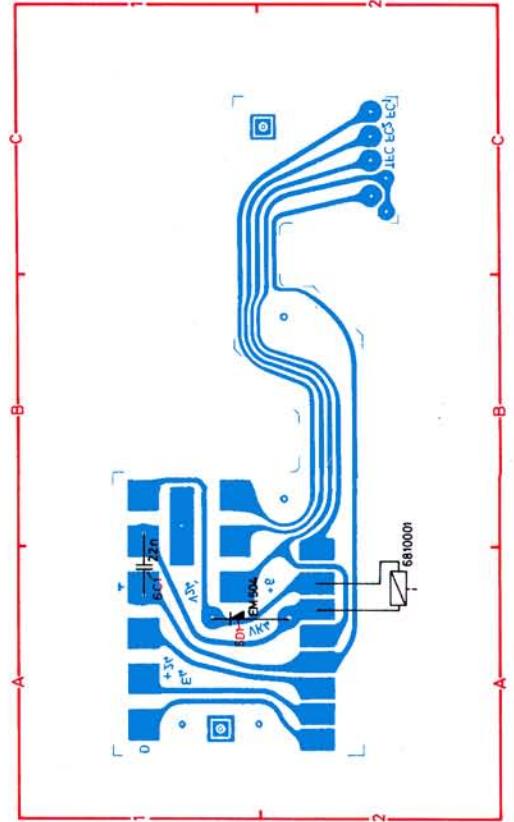

Pos.	Plac.	Symbol	Index
2TR 1	B2	TR	8320097
2TR 2	B2	TR	8320097
2TR 3	A2	TR	8320097
2TR 4	A2	TR	8320097
2TR 5	A2	TR	8320097
2TR 6	B1	TR	8320124
2TR 7	B1	TR	8320097

Pos.	Plac.	Symbol	Index
2MS 1	A1	MS	6810004
2MS 2	A1	MS	6810004
2MS 1	A1	MS	7600013
2MS 2	A1	MS	7600013

6 PC 8009019

6 PC 8009019



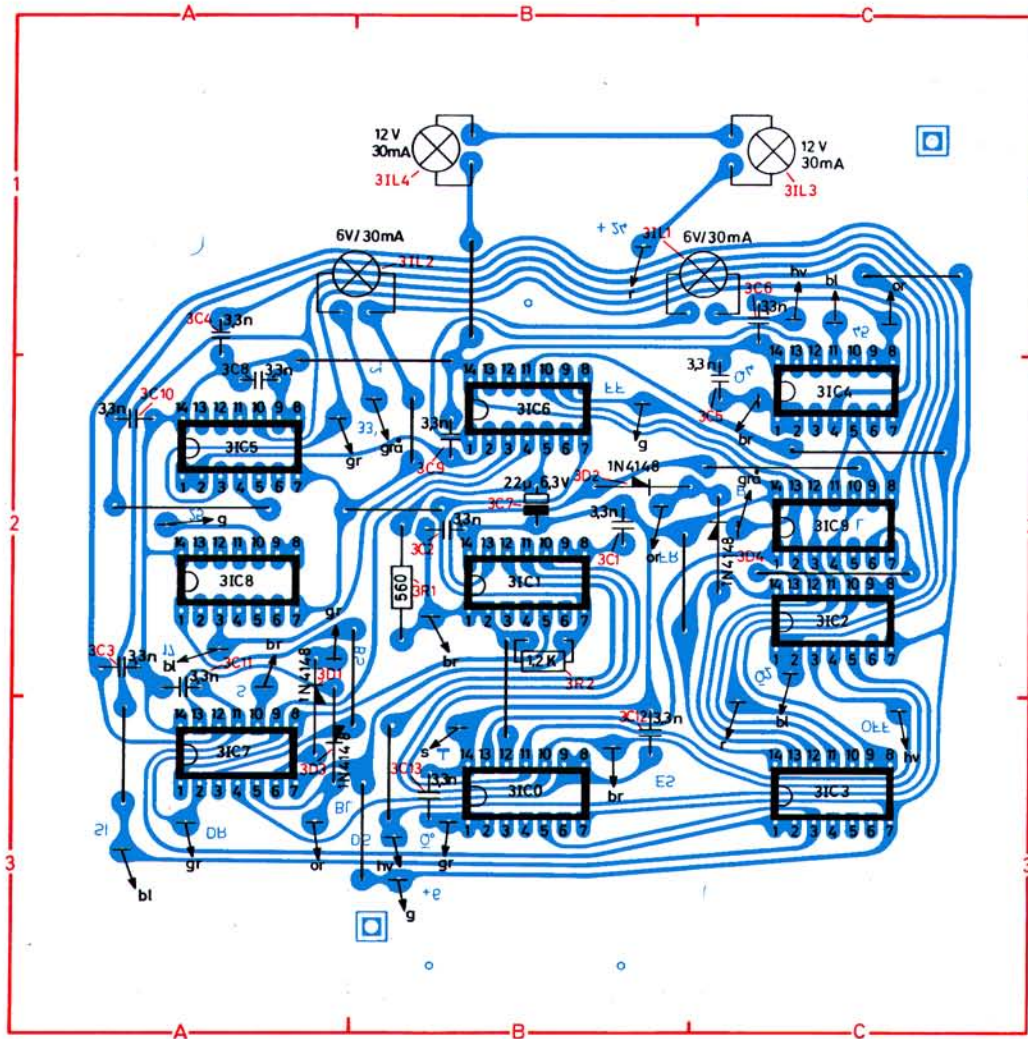

Pos.	Plac.	Symbol	Index
6C 1	A1	C	4130096
6D 1	A1	D	8300102

3 PC 8009015

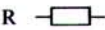

SET FRA KOMPONENTSIDE / SEEN FROM COMPONENT SIDE / VON DER BAUTEILSEITE AUS GESEHEN

3 PC 8009015

Pos.	Plac.	Index	IC	IC	
		R 		IC 	
3R 1	B2	560, 5 %, 1/8 W	5010067	3IC0	B3 FCH131 8340013
3R 2	B2	1,2 k, 5 %, 1/8 W	5010153	3IC1	B2 FCH131 8340013
		C 		3IC2	C2 FCH131 8340013
3C 1	B2	3,3 n, 100 V, 10 %	4011025	3IC3	C3 FCH131 8340013
3C 2	B2	3,3 n, 100 V, 10 %	4011025	3IC4	C2 FCH131 8340013
3C 3	A2	3,3 n, 100 V, 10 %	4011025	3IC5	A2 FCH131 8340013
3C 4	A1	3,3 n, 100 V, 10 %	4011025	3IC6	B2 FCH111 8340012
3C 5	C2	3,3 n, 100 V, 10 %	4011025	3IC7	A3 FCH131 8340013
3C 6	C1	3,3 n, 100 V, 10 %	4011025	3IC8	A2 FCH131 8340013
3C 7	B2	22 µ/6,3 V	4200218	3IC9	C2 FCY101 8840011
3C 8	A2	3,3 n, 100 V, 10 %	4011025		IL 
3C 9	B2	3,3 n, 100 V, 10 %	4011025	3IL1	B1 6 V, 30 mA 8230041
3C10	A2	3,3 n, 100 V, 10 %	4011025	3IL2	B1 6 V, 30 mA 8230041
3C11	A2	3,3 n, 100 V, 10 %	4011025	3IL3	C1 12 V, 30 mA 8230040
3C12	B3	3,3 n, 100 V, 10 %	4011025	2IL4	B1 12 V, 30 mA 8230040
3C13	B3	3,3 n, 100 V, 10 %	4011025		
		D 		BEOGRAM 4000, TYPE 5215	
3D 1	A2	1N4148, SFD 184	8300058	Correct on page 3-8	
3D 2	B2	1N4148, SFD 184	8300058	3IL3	C1 24V/25mA 8230044
3D 3	A3	1N4148, SFD 184	8300058	3IL4	B1 24V/25mA 8230044
3D 4	C2	1N4148, SFD 184	8300058		

1 PC 8009012

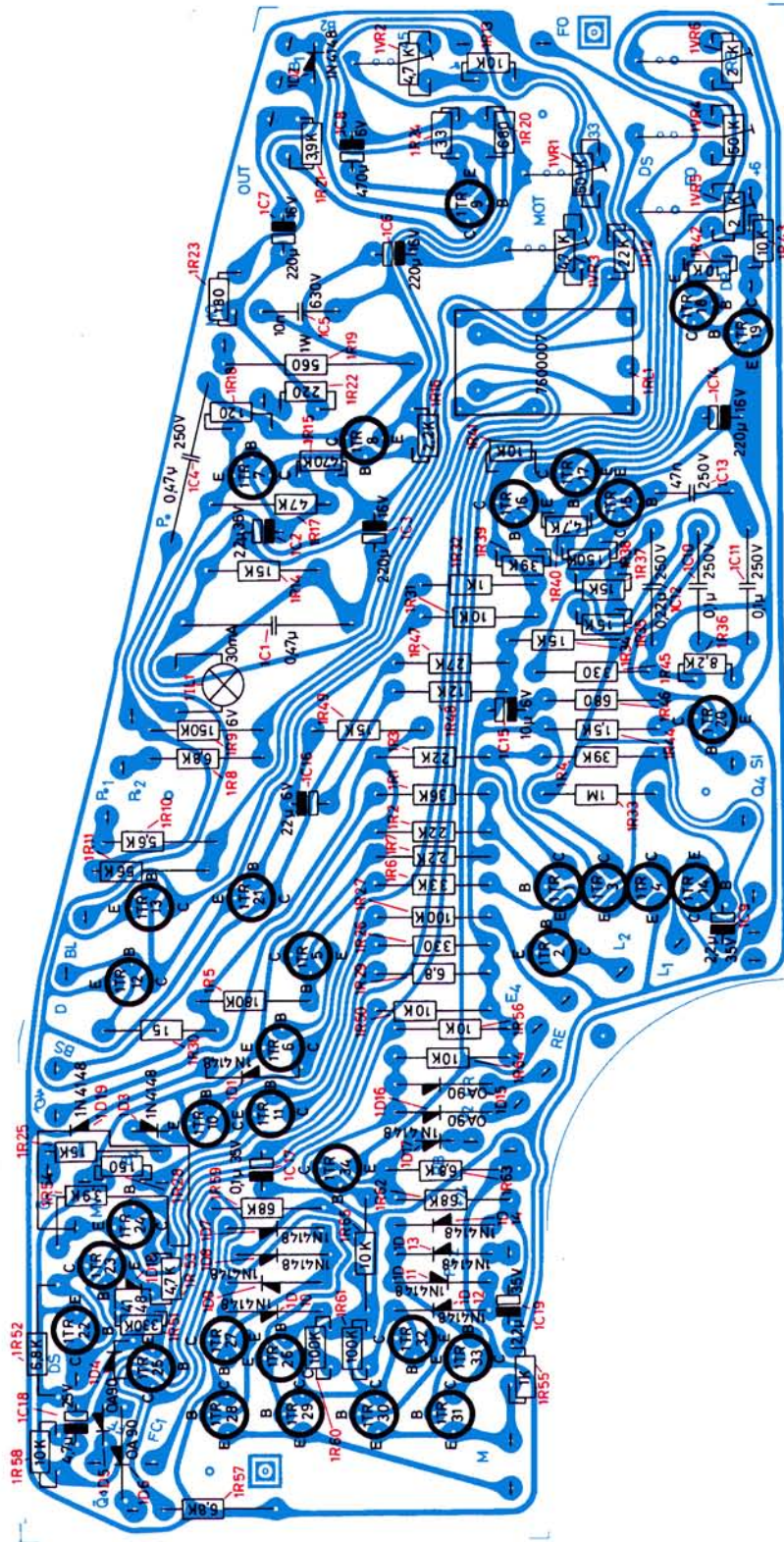

SET FRA PRINTSIDE / SEEN FROM CONDUCTOR SIDE / VON DER LEITERSEITE AUS GESEHEN

MECHANICAL ADJUSTMENTS

Height Adjustment of Turntable

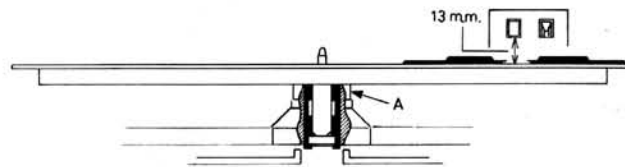

Loosen nut A at the turntable bearing and adjust the height of the bearing so that the spacing between the turntable and the detector arm is 13 mm.

Tighten nut A lightly.

Vertical Adjustment of Turntable Bearing

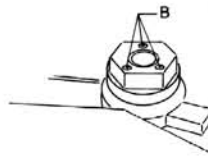

Turn the transit screws to lock the floating chassis.

With screws B adjust the turntable bearing so that it is at right angles to the chassis – in other words so that the turntable surface is parallel with the cover plate.

Check height adjustment (13 mm) at both the rim and centre of the turntable.

Height and Side Adjustment of Chassis

Loosen transit screws so that chassis floats freely.

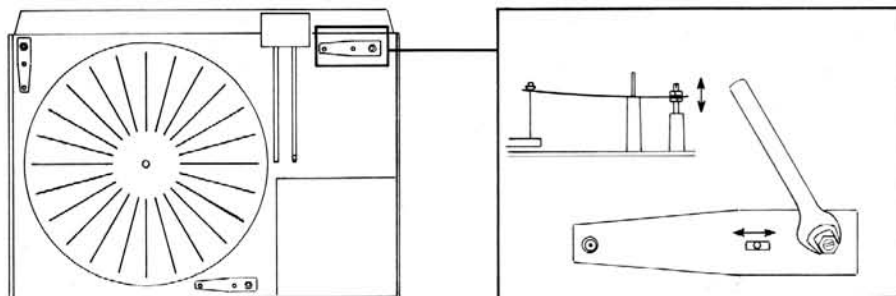

With the suspension springs adjust the chassis so that the turntable is flush with the cover plate and so that the chassis is centered with respect to the transit screws.



Also slide the springs backwards and forwards to locate the turntable centrally in the cutout in the cover plate.

To make this adjustment loosen the top nuts and thereafter adjust the screw to the desired height and slide the springs to the desired position. Thereafter retighten the nuts.

Adjustment of Belt Drive

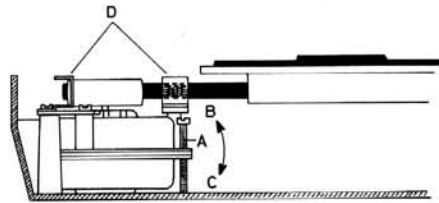

Adjust the belt so that it runs on the middle of the pulley and the belt face on the turntable.

To shift the belt farther down on the pulley, turn screw A so that the motor tilts in the direction of arrow B.

To shift the belt farther upwards, loosen screw A and bend the motor suspension in the direction of arrow C. Thereafter tighten screw A until the belt runs on the middle of the pulley.

Adjust belt guides D so that they prevent the belt from running upwards or downwards off the pulley and so that they do not touch the belt during operation.

NOTE: The belt must be placed so that its ground (rough) side faces the pulley and turntable.

Adjustment of Stroboscope

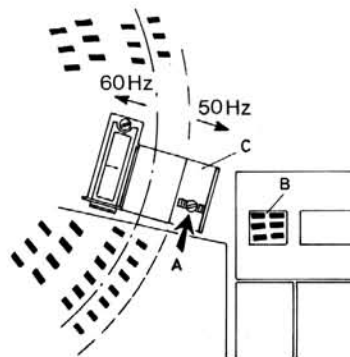

Loosen screw A.

Adjust bracket C with the mirror so that the stroboscope image is located in the middle of the field of vision.

Tighten screw A.

NOTE: The two outer rows are for 50 Hz and the two inner ones are for 60 Hz.

Adjustment of Slide Contact Springs

Height



Adjust all contact springs so that they only just actuate the contacts but also so that they do not jam against the contact pins, thus obstructing the slide transport.

Placement

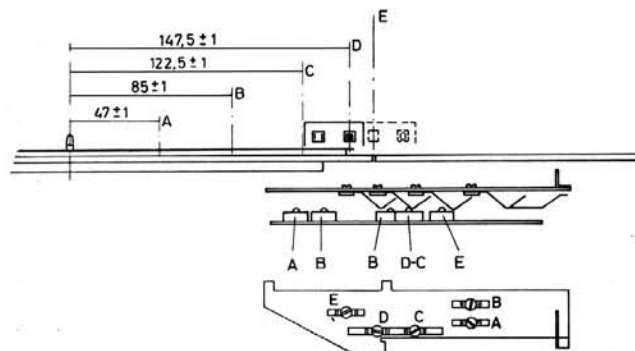

Adjust the horizontal placement of the springs so that, during slide transport, they will actuate their respective contacts when the pickup is spaced from the middle of the record spindle by the amount indicated in the sketch.

To adjust, loosen the screws holding the single spring and slide it in the oblong hole.

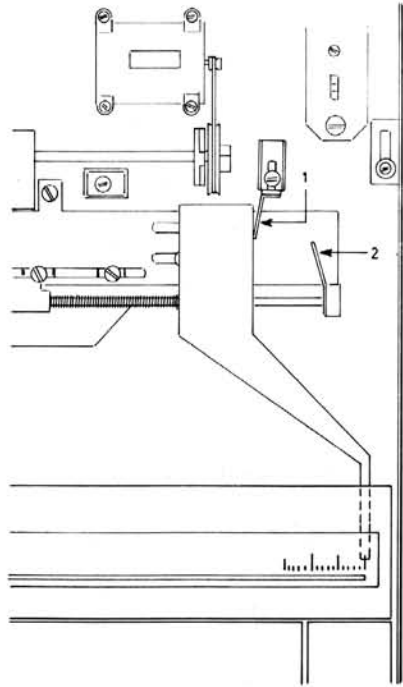
Adjustment of Dial Pointer**Zero Adjustment**

Zero adjustment is performed by bending the tag 1 with the slide in its extreme right-hand position.

Start Adjustment

Adjust (bend) angle 2 so that the pointer begins to move away from "0" when the pickup lowers into the first groove of a 30 cm record.

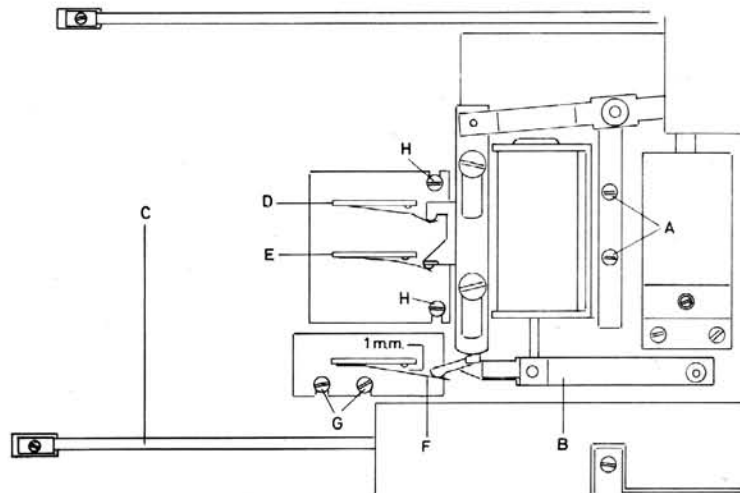
Adjustment of Magnet Coil System**Magnet Coil**

Loosen screws A.

Slide the magnet coil to the place where the arm B is parallel with tie-bar C when the magnet coil armature has been pulled home.

Tighten screws A.

Contacts F

Contacts F, which cut in the power limiter circuit, should be adjusted so that they are spaced 0.5 - 1, with the magnet coil armature pulled home.

To adjust, loosen screws G.

Contacts D and E

Contacts F and G should be adjusted so that the contact functions are not performed until the pickup stylus is in contact with the record but on the other hand as quickly as possible after the stylus hits the record.

Moreover, contacts E, of the duplex type, should be adjusted so that the upper contacts break first and the lower ones immediately afterwards.

Contacts D turn on the servo mechanism. Contacts E connect the pickup signal leads together and short-circuit them.

Adjustment of Pickup Arm System

Horizontal Placement (Fixing)

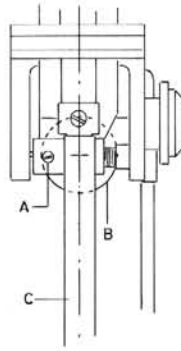

Place the pickup arm in a bearing frame so that the centre line C of the pickup arm is located on the centre line of the shaft B with an accuracy of ± 0.2 mm.

To make the adjustment, loosen screw A and slide the pickup arm in one direction or the other, thereafter retightening screw A.

Static Balance

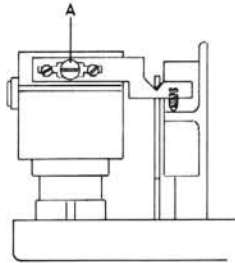

Set stylus adjustment to "0".

Release pickup arm from lifting arm.

Adjust screw A until balance is obtained in the system.

Length, Height and Parallel Adjustment

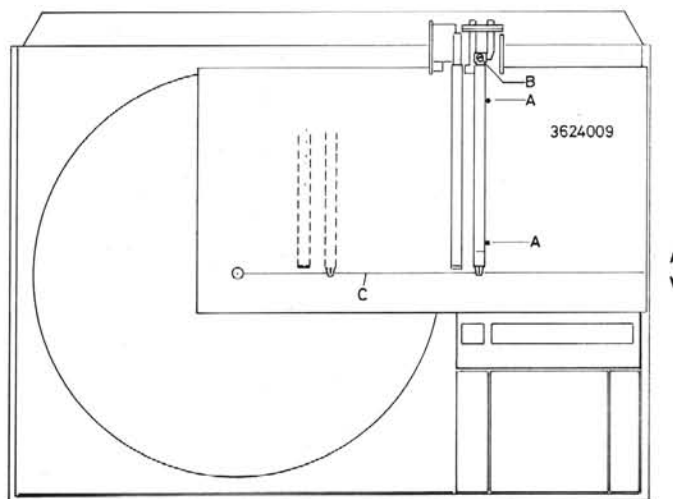

Adjust stylus force to 1 gr. Take off turntable. Run pickup arm in towards the centre.

Mount tool 3624009 on the Beogram 4000 as shown by sketch. Run pickup arm out close to pins A. Lower pickup on to tool. Slide tool backwards or forwards so that stylus drops into groove C. Keep tool fixed in this position. Raise pickup and run it towards the centre. Lower pickup into the position shown in the sketch. If the stylus hits outside groove C, adjust screw B so that the deviation in question is halved. Run the pickup arm all the way out close to pins A. At this point lower the pickup and slide tool 3624009 so that the stylus is exactly in groove C. Raise the arm and now check if the arm is equally spaced from the pins A. Also make sure that the lifting arm rests in the bottom of the V-notch E on the arm D.

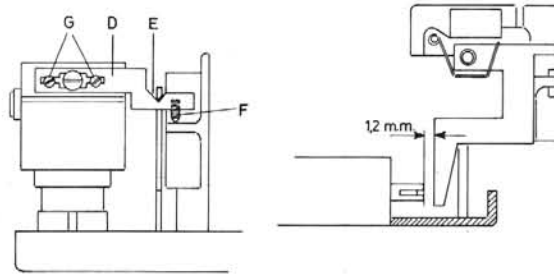

If the pickup arm is not parallel with the line between pins A, loosen screws G and slide arm D backwards or forwards until parallelism has been accomplished (the lifting arm must be in the bottom of the V-notch during this adjustment).

NOTE: Length adjustment of the pickup arm should be checked after adjustment of the arm D.

Adjust screw F so that the arm is horizontal (reference to detector arm) and so that the lifting arm is spaced $1.2 \text{ mm} \pm 0.3 \text{ mm}$ from the damper cylinder as shown by the sketch. It may be necessary to tilt the arm D when making this adjustment.

NOTE: If the arm D is to be tilted, the parallel adjustment of the pickup arm must be checked and repeated if necessary. Check static balance and readjust if necessary.

Lowering (Depth) Adjustment

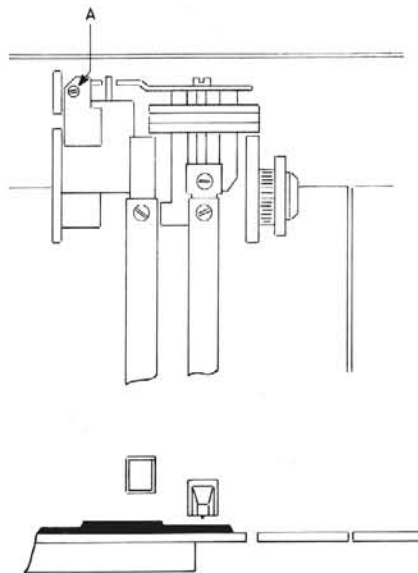

Adjust screw A with the pickup arm lowered so that the stylus clears the low portions of the turntable ribs (by approx. 0.5 mm).

Adjustment of Diaphragm

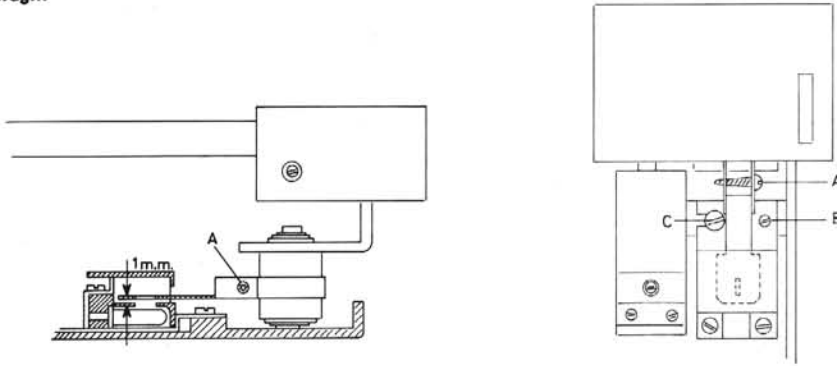

The diaphragm is adjusted by loosening screw A and turning and sliding it on the arm bearing.

Adjustment should be made so that the 1 mm spacing shown is complied with and so that the diaphragm arm becomes parallel with the pickup arm.

Fine adjustment of the diaphragm is performed with a record placed on the turntable and the drive belt removed.

- 1: Run arm in over record.
- 2: Lower pickup.
- 3: Turn turntable by hand, checking that first operation of servo system occurs after 4 ± 1 turns and thereafter at every turn.
- 4: If the servo system does not operate within 4 ± 1 turns, loosen screw C and adjust eccentric B. Thereafter raise the arm and repeat items 2 - 4.
- 5: After adjustment of eccentric B, screw C should be tightened.
- 6: Make sure that the servo system does not regulate backwards until after the turntable has turned at least 10 cm backwards from the forwards regulation. To make adjustment if necessary, correct the spacing (1 mm) between the diaphragm and the photoresistor.

Adjustment of Damper Cylinder

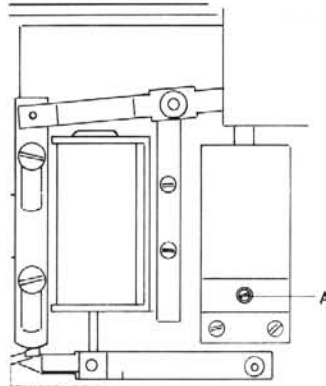

Adjust valve A so that pickup lowers in between 1 and 1.5 sec.

Adjustment of Spindle

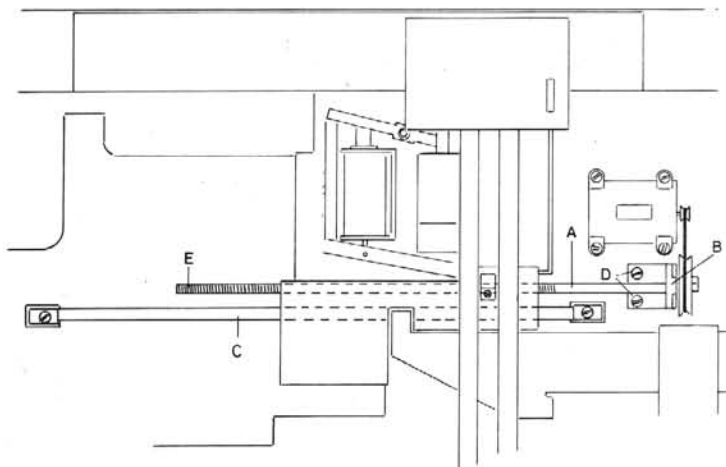

Adjust spindle A so that it is parallel with tie-bar C.

To adjust, loosen screws D and turn cap B.

Best parallelism is obtained when spindle A has minimum eccentricity at E during operation.

ELECTRICAL ADJUSTMENTS

Remove Beogram 4000 cover plates (see Disassembly).

Speed Adjustment

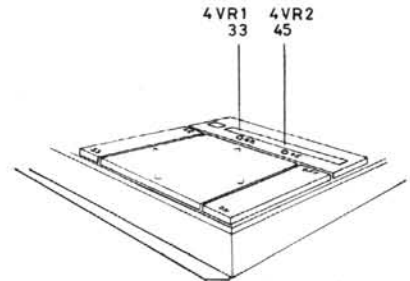
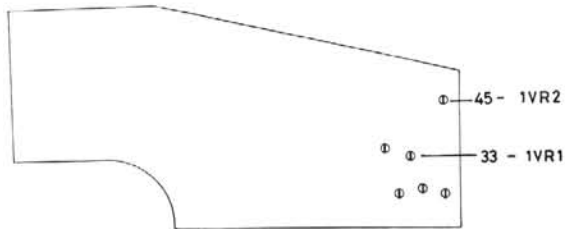

Connect the instrument to the mains. Press On and thereafter LIFT so that the pickup arm is stationary and the turntable is rotating. Set 33 r.p.m. potentiometer 4VR1 at mid-scale. Adjust 33 r.p.m. potentiometer 1VR1 so that 33 r.p.m. stroboscope dial appears to be standing still. Set 45 r.p.m. potentiometer 4VR2 at mid-scale. Adjust 45 r.p.m. potentiometer 1VR2 so that 45 r.p.m. stroboscope dial appears to be standing still.

Adjustment of Slow Slide Transport

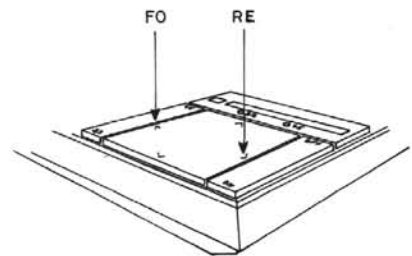
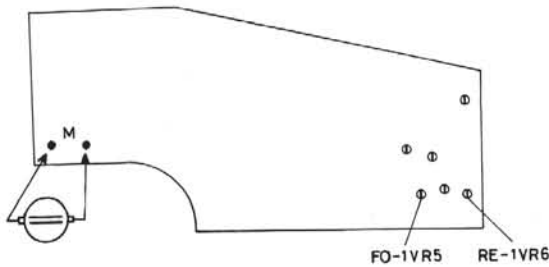

Connect a vacuum-tube voltmeter across the DC motor at M. Set vacuum-tube voltmeter at mid-scale and switch to 10-volt range. Applying light pressure to the in-transport panel (FO), adjust 1VR5 (FO) until the vacuum-tube voltmeter reads between 2.5 and 3.0 volts. Adjust 1VR6 (RE) so that a similar reading in the opposite direction is obtained when the transport panel (RE) is pressed lightly.

Adjustment of Voltage for Drive Motor

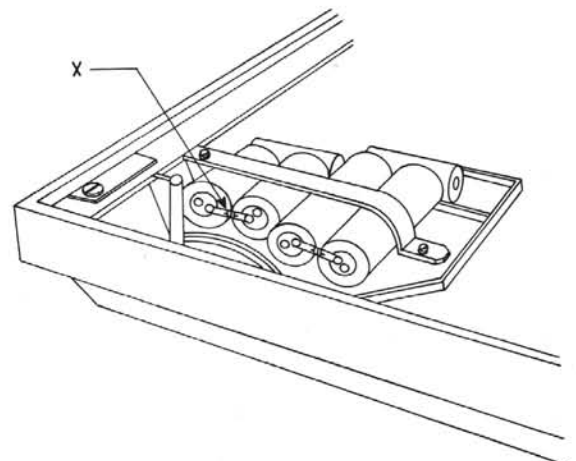
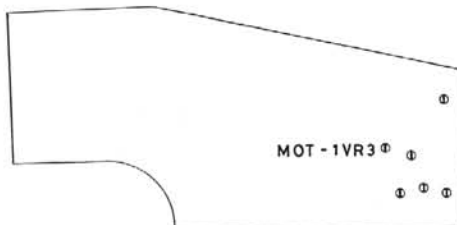

Connect AF voltmeter and oscilloscope at point X so that measurement is made with respect to chassis (0). In the 33 r.p.m. position, adjust potentiometer 1VR3 for maximum voltage though not more than 6.5 volts r.m.s. or approx. 18 volts p-p and so that distortion does not occur.

Adjustment of Differential Stop

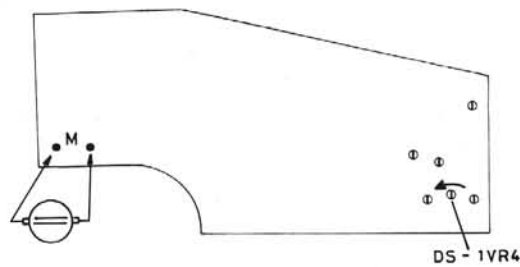

Connect oscilloscope with disabled D-deflection across the motor at M.

Run the slide in so that MV contacts are operated.

Lower the arm before the run-off groove is reached on a 17 cm record.

Adjust potentiometer 1VR4 so that the stop releases when motor voltage is 1.8 volts.

Thereafter make sure that the stop releases on a 30 cm record.

LUBRICATION

The need for relubrication is very little. The instructions below should be followed for overhauls and replacement of important mechanical parts.

Bearing for arm 195 Bearing for arm 198 Bearing for arm 205 Spindle 224 Bearing for turntable 100	Everyman oil 3984211
Damper cylinder 255	Dow corning 200 fluid 3984214
Spring 192 Spring 199 Shaft 60 Bearing for spindle 122 Shaft for position giver 227 Under pointer 229	Beacon Q 3984210

FAULT-FINDING SYSTEMATICS**Testing and Fault-finding Diagram**

The diagram is composed by means of four symbols.

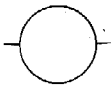

A circle denotes an activity that must be carried out in order for the test to continue.

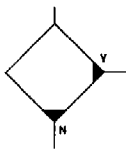

A square standing on end contains a question that must be answered with yes or no, thereafter continuing in the direction of the answer, Y or N.

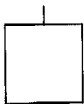

This square gives the designations of the main components of the circuit to be repaired.



A triangle refers to a previous section.

The question in the preceding square is found in the section to which reference is made, thereafter continuing in the direction of Y or N.

If the top horizontal line can be traced without encountering a no-answer, the controlling functions of the set will be O. K.

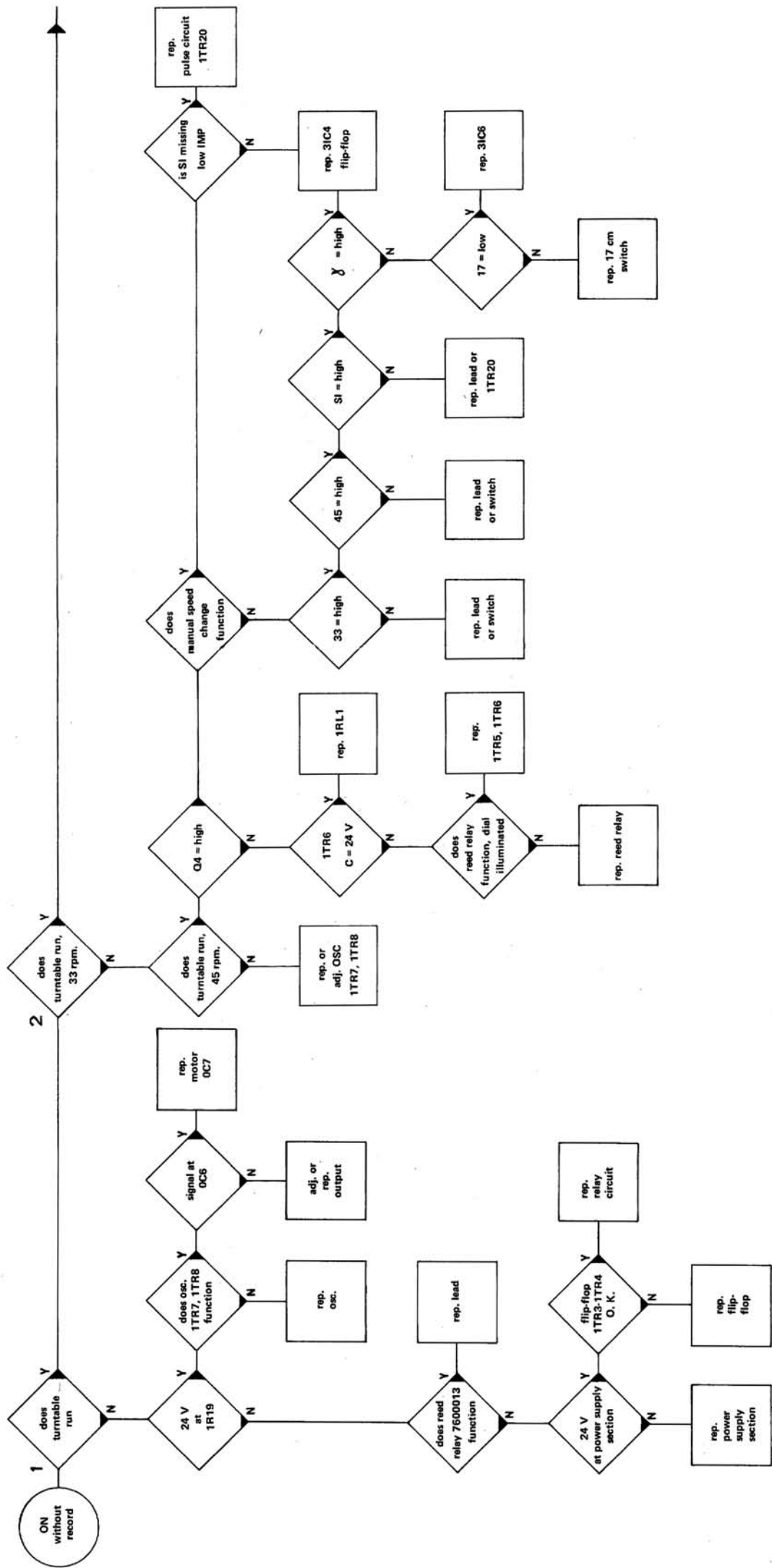

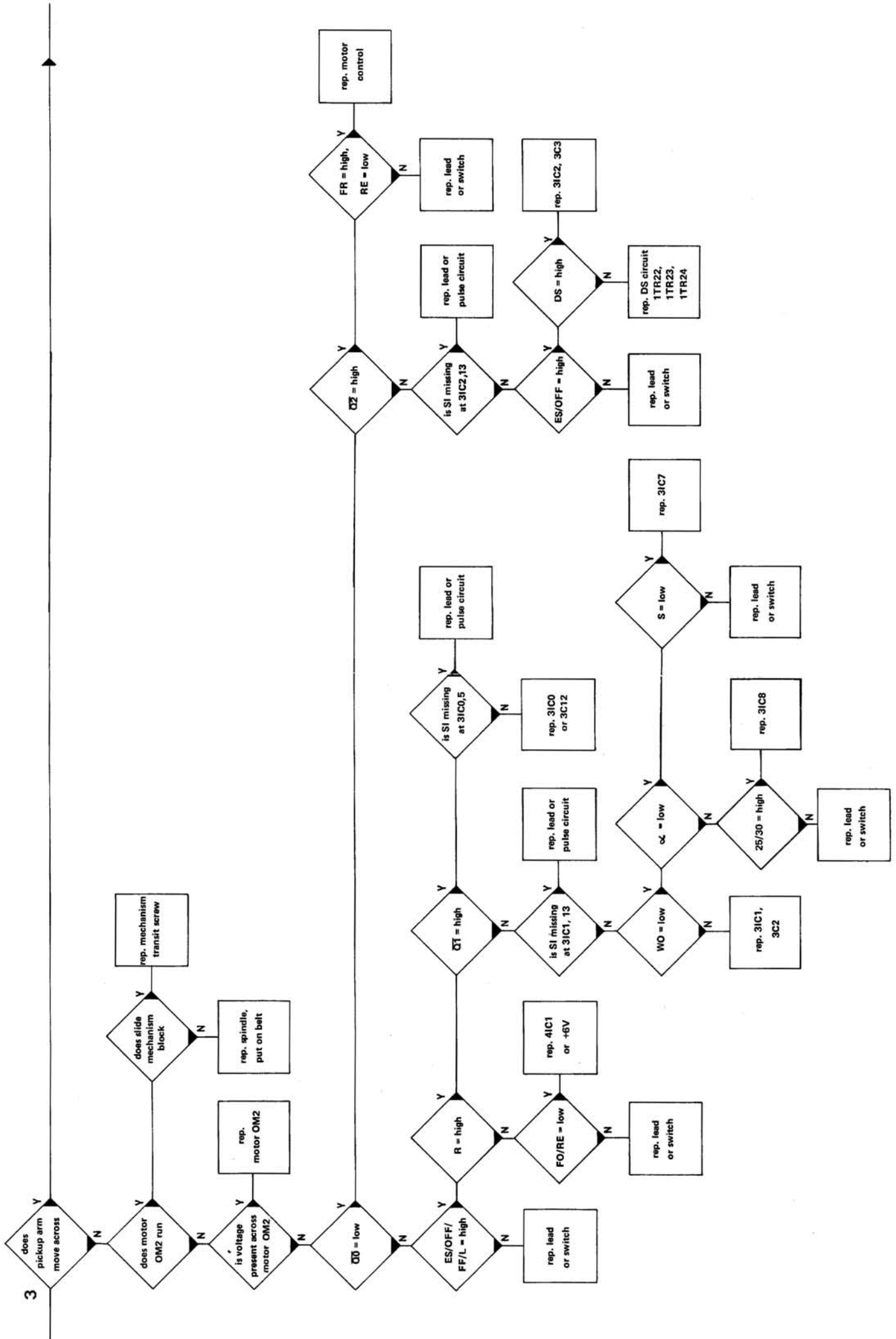

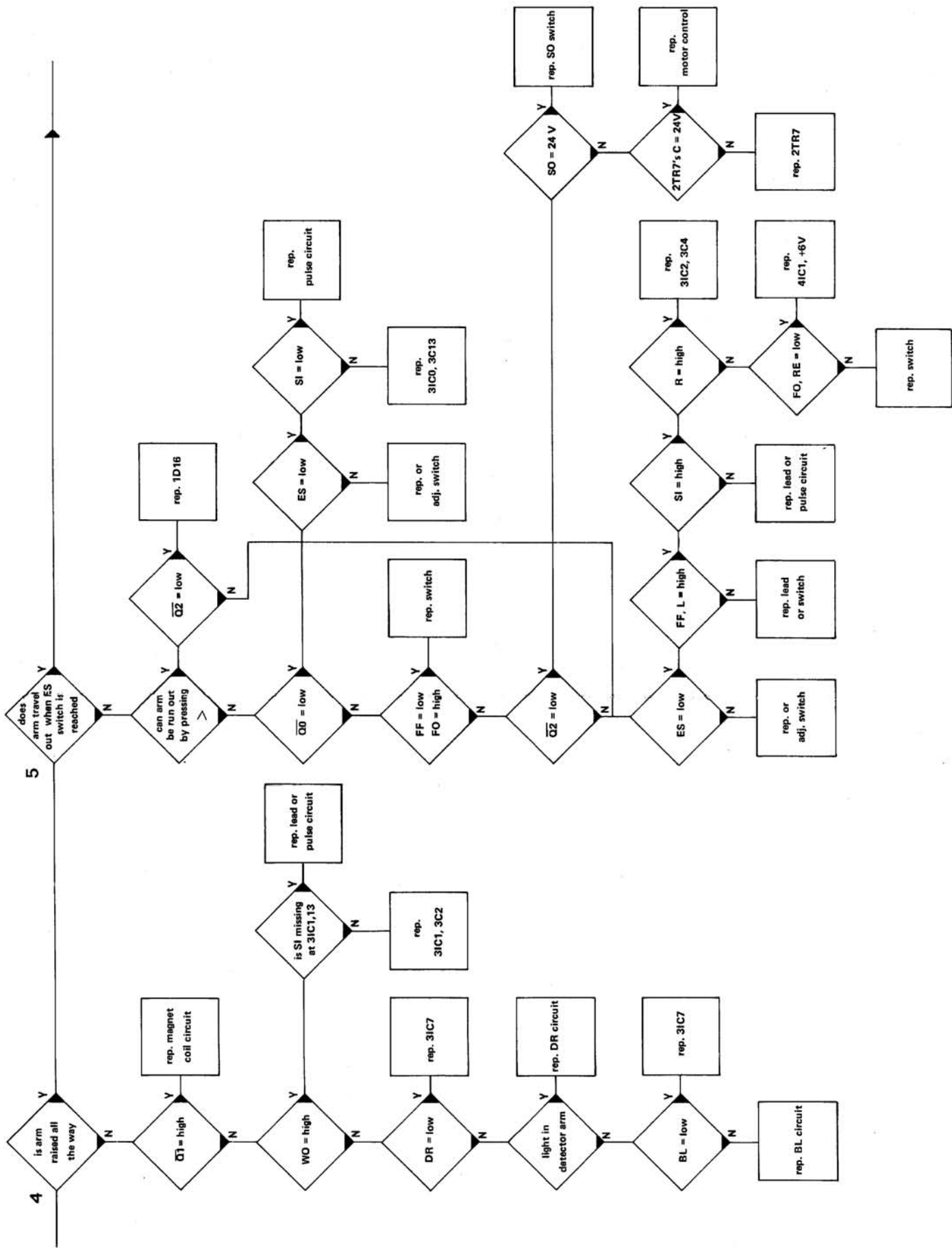

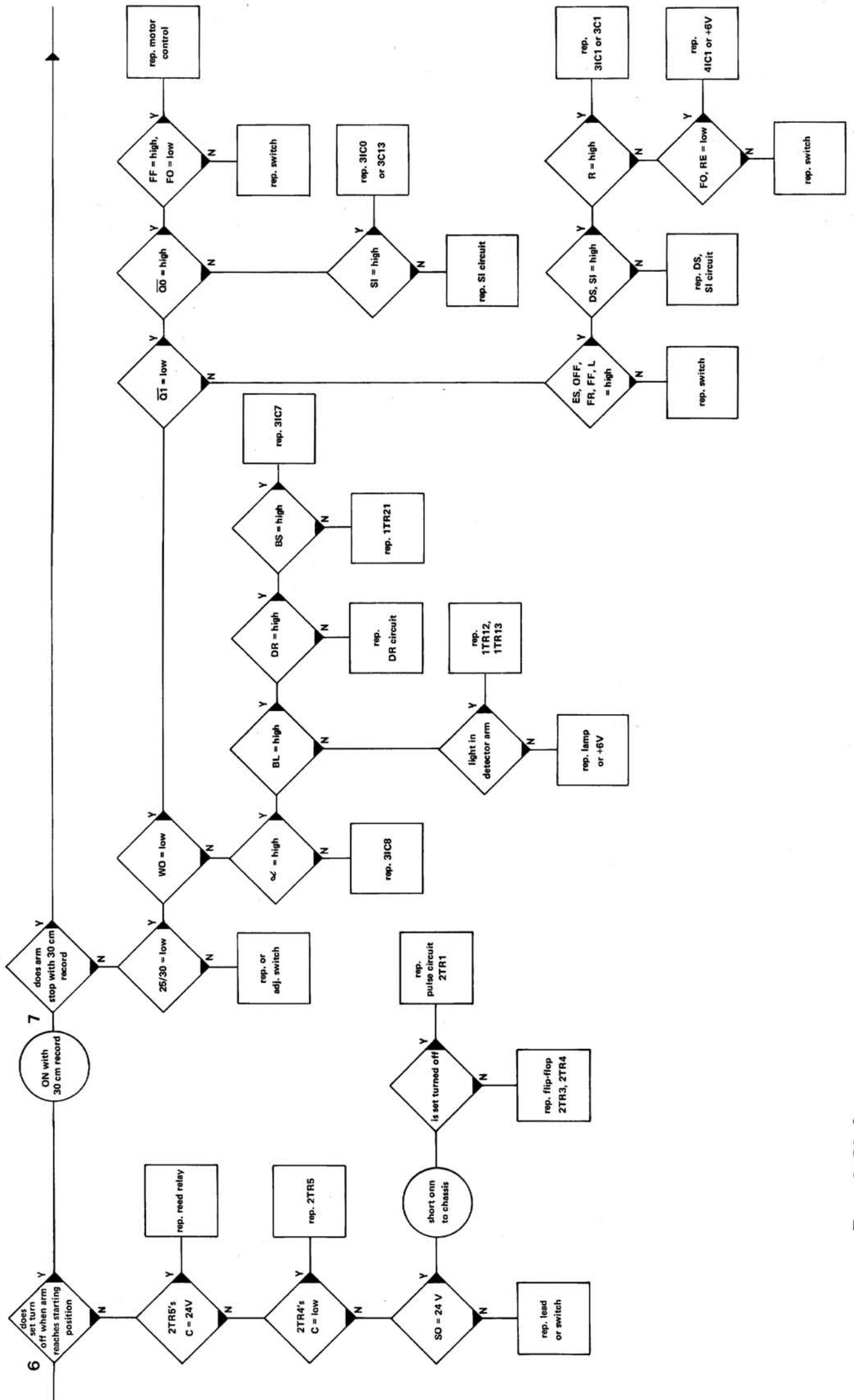

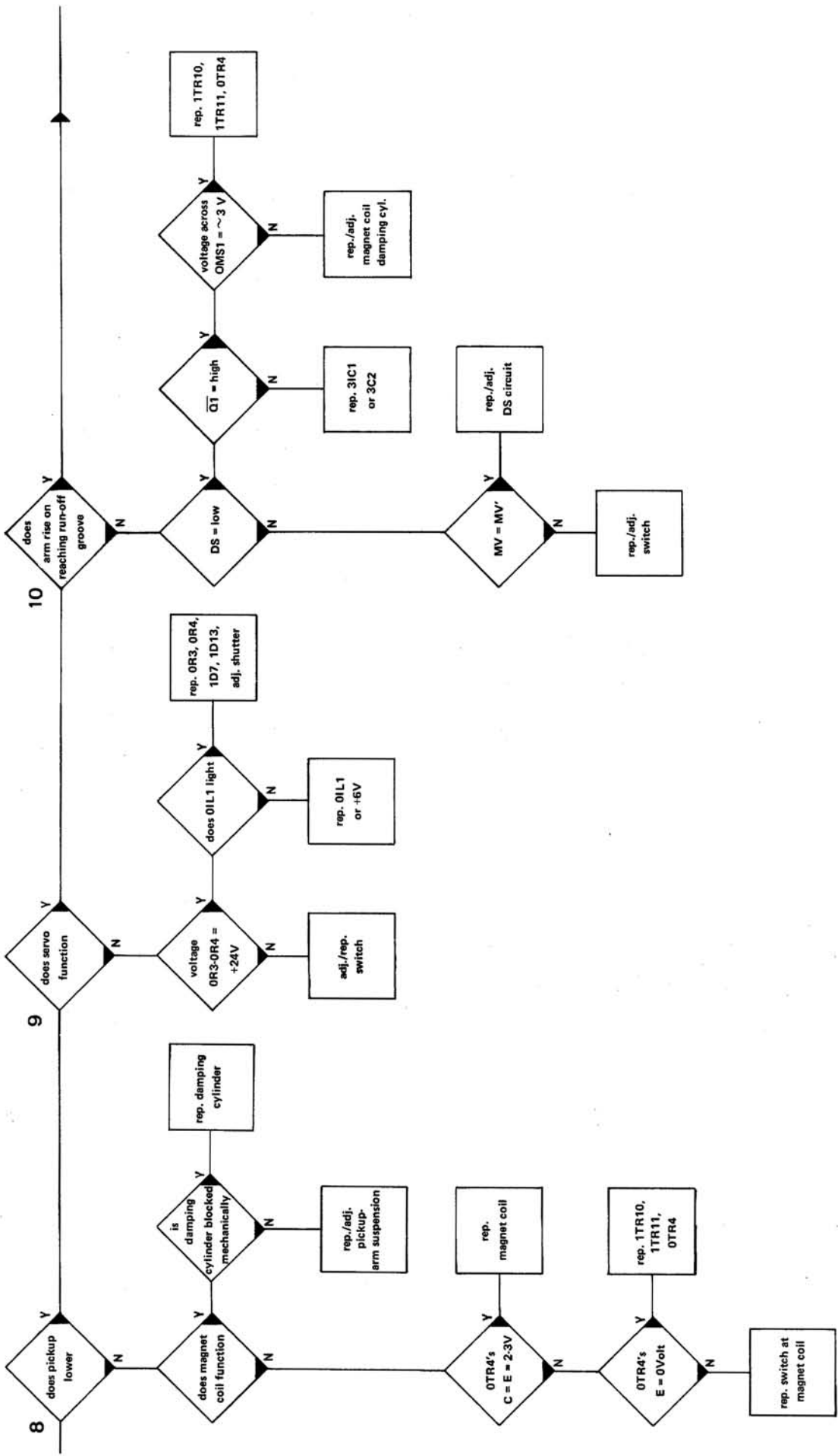

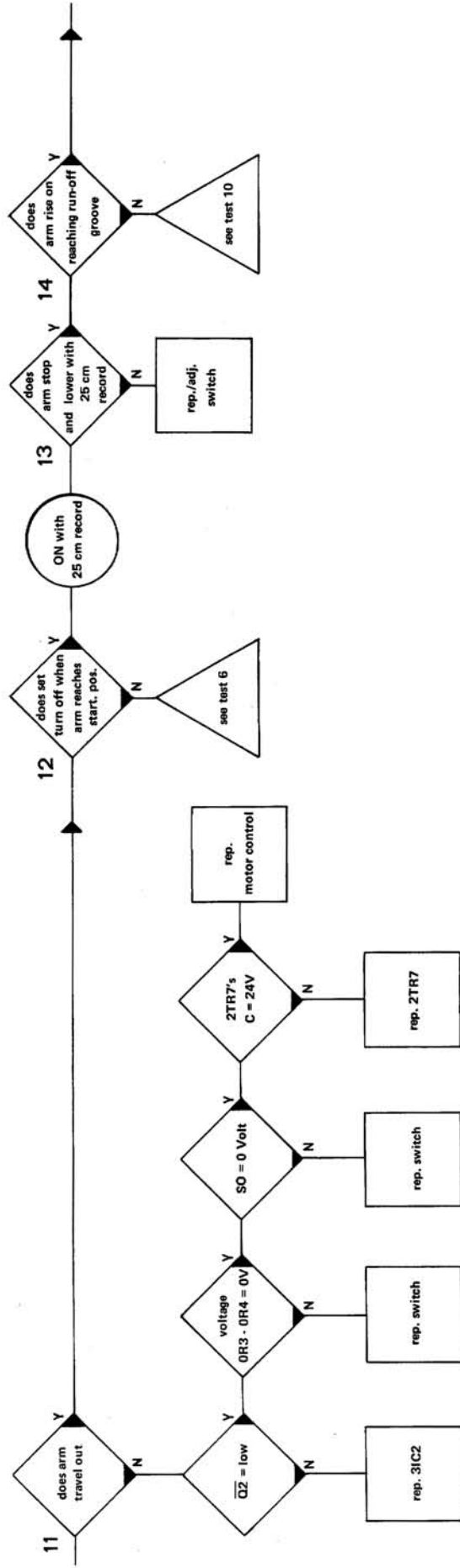

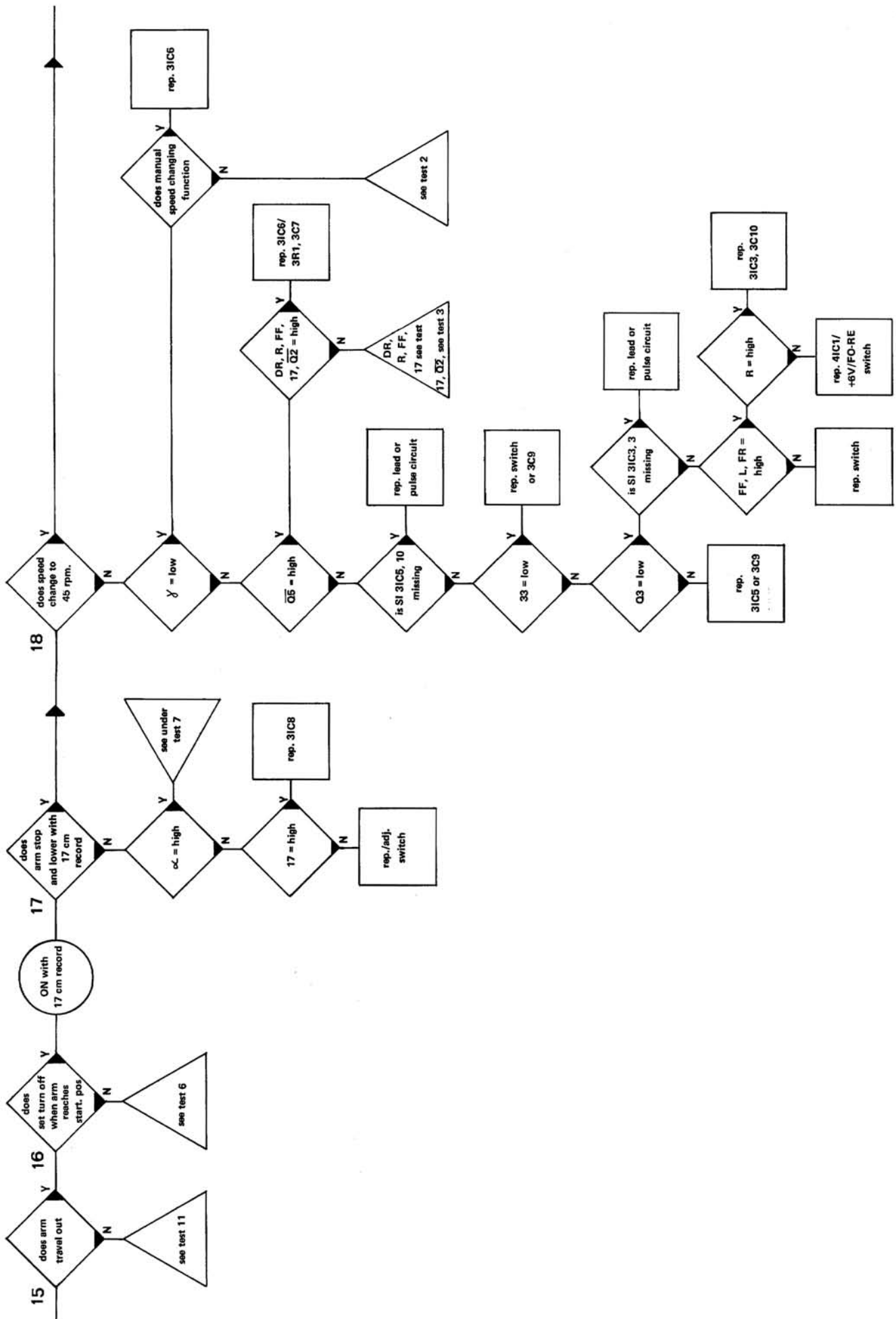

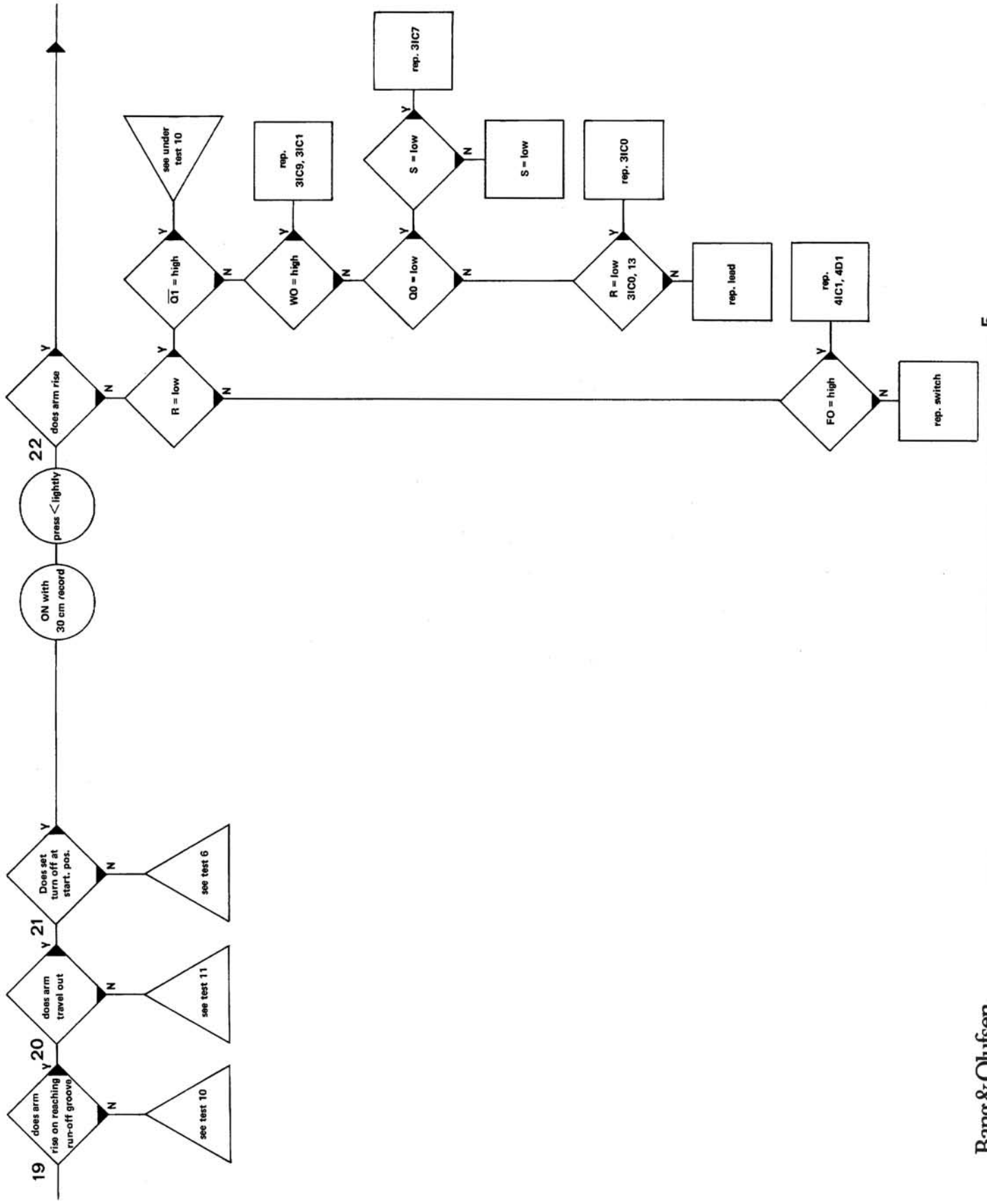

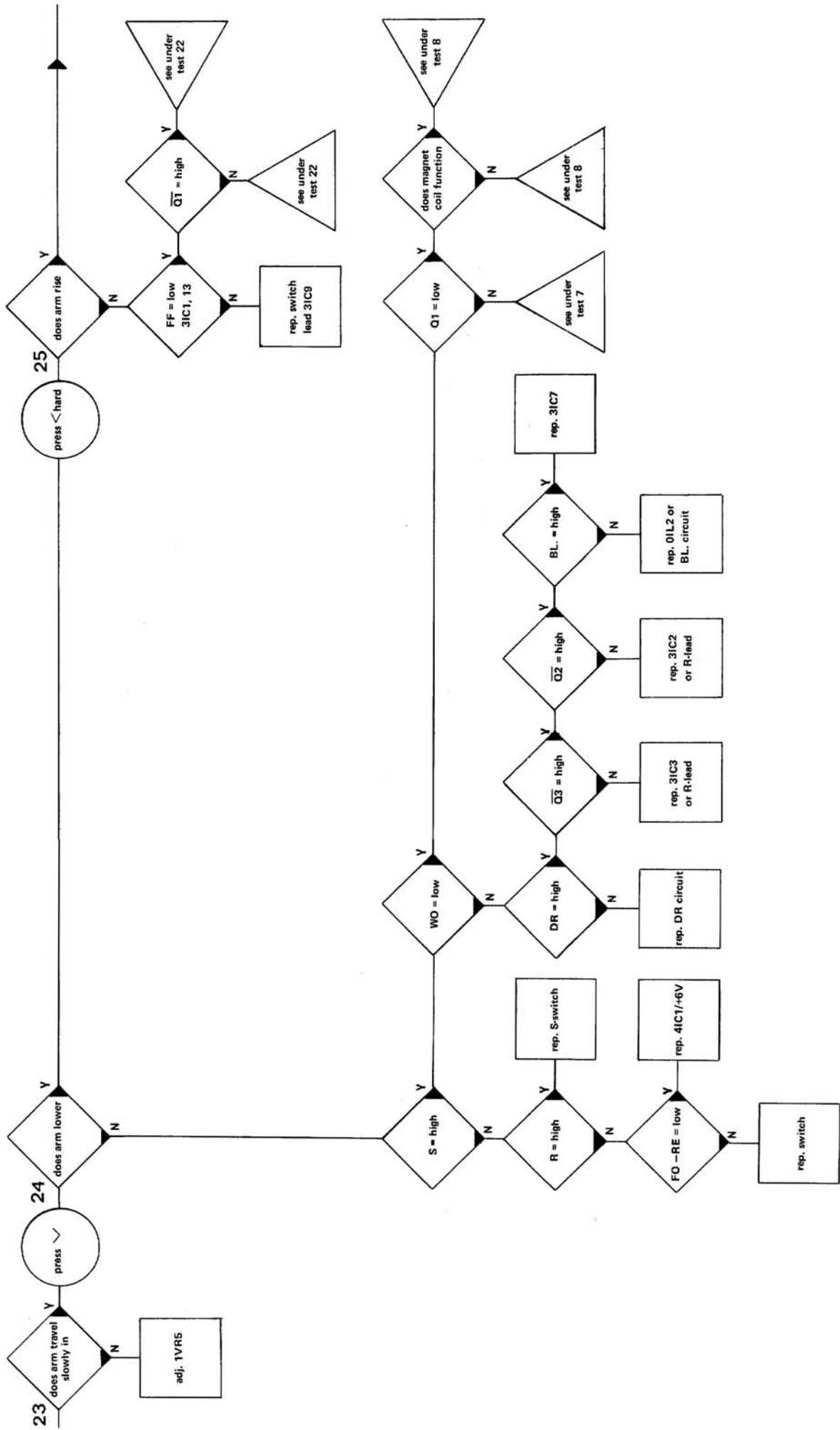

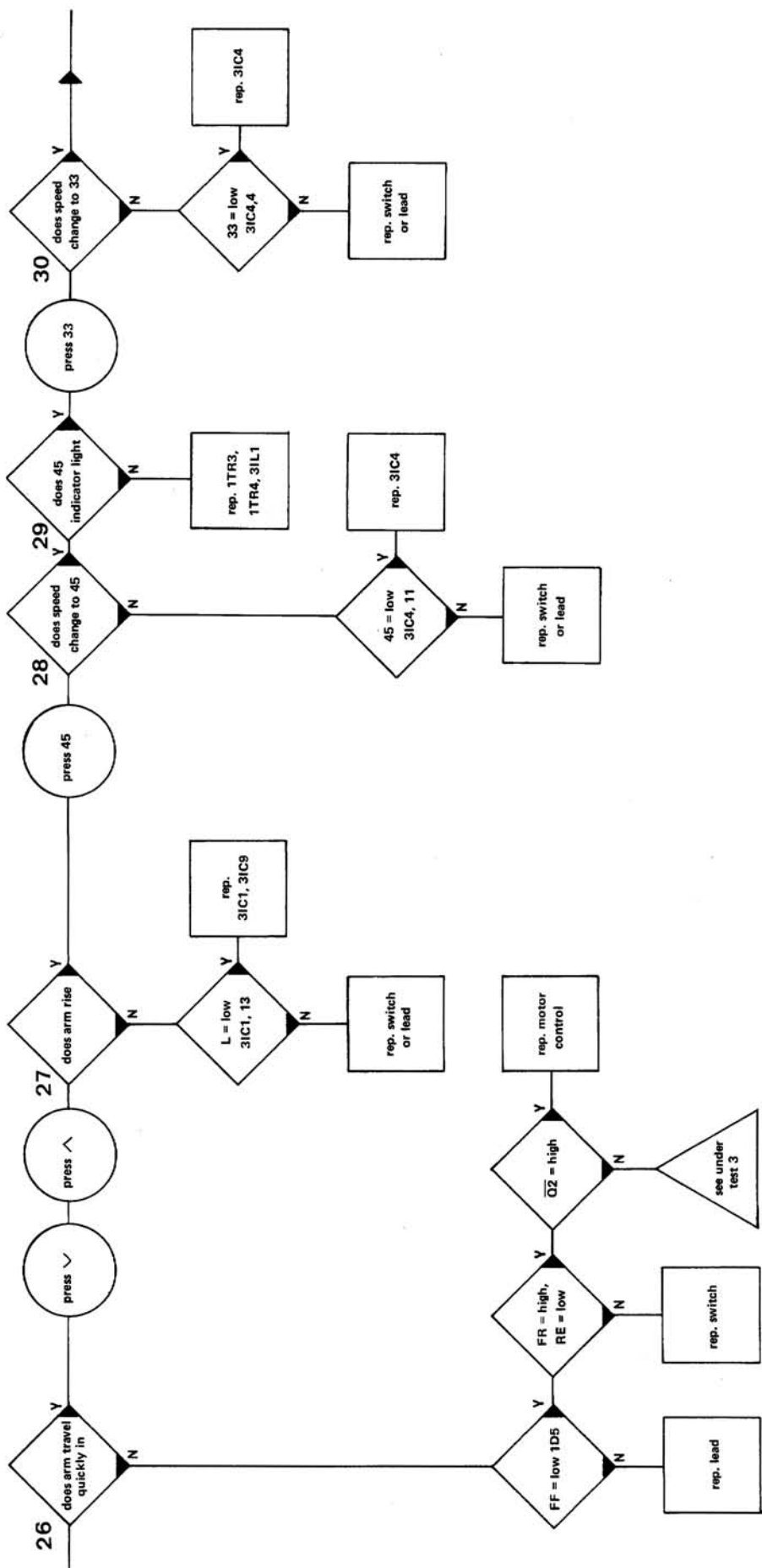

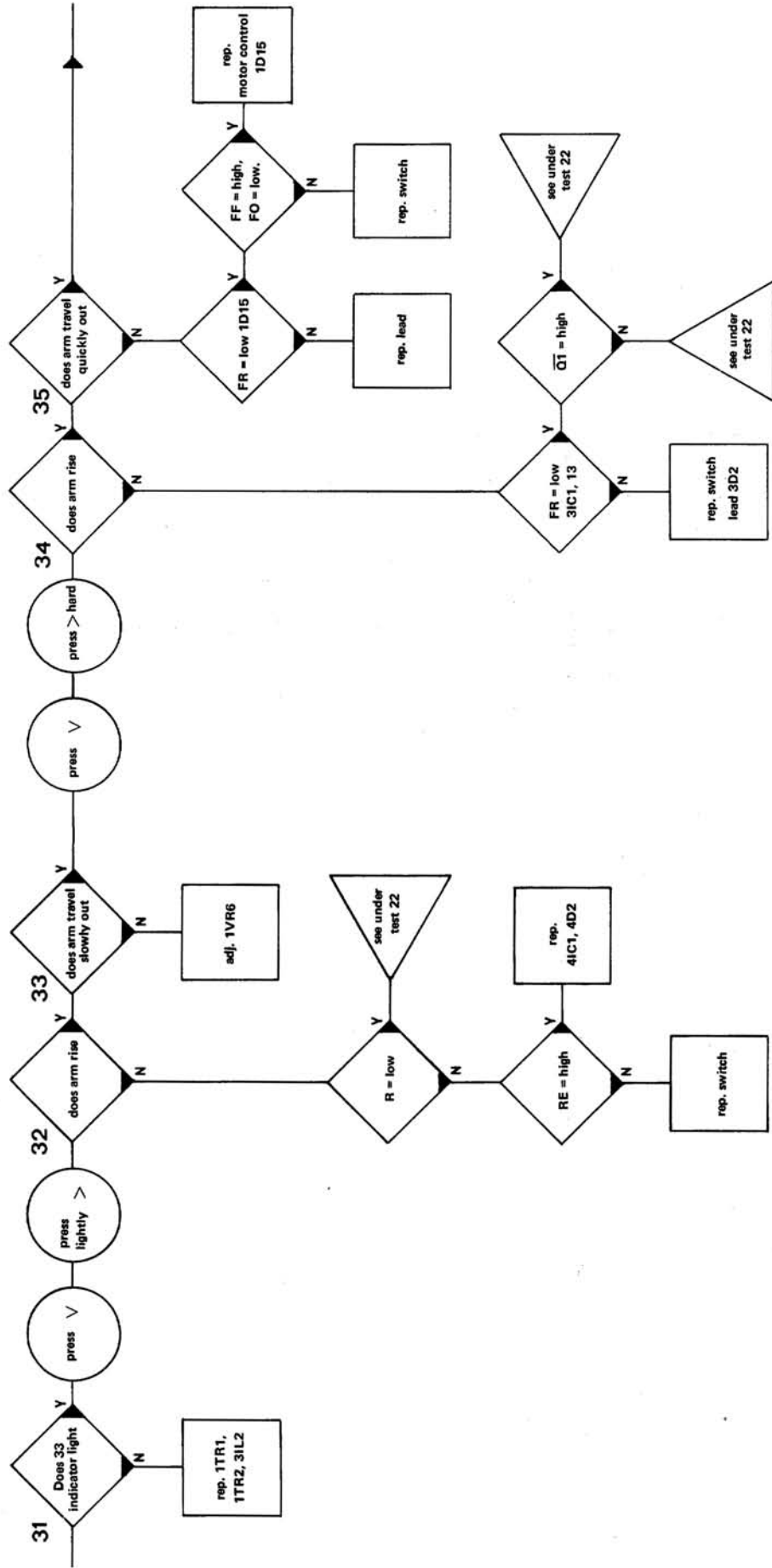

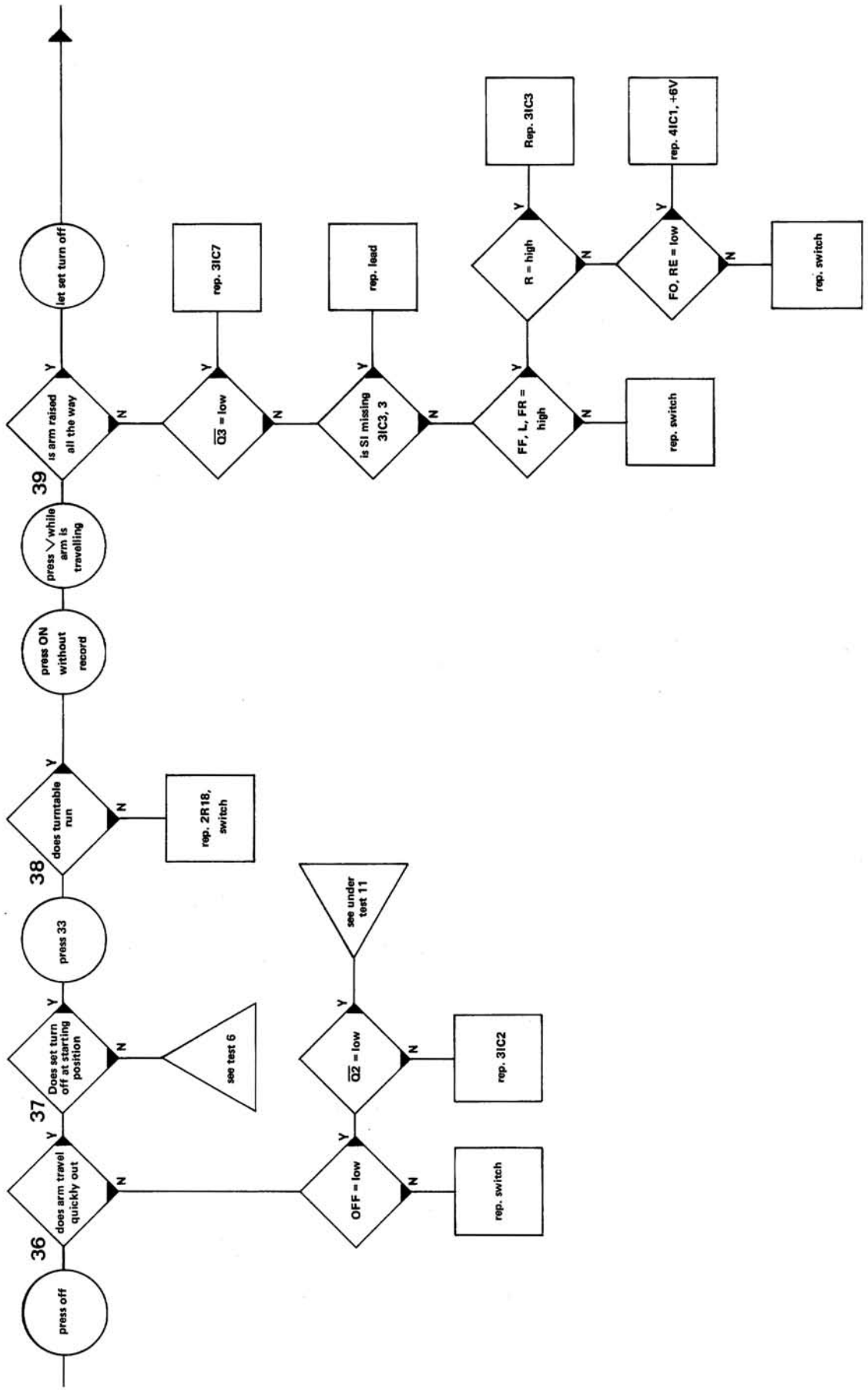

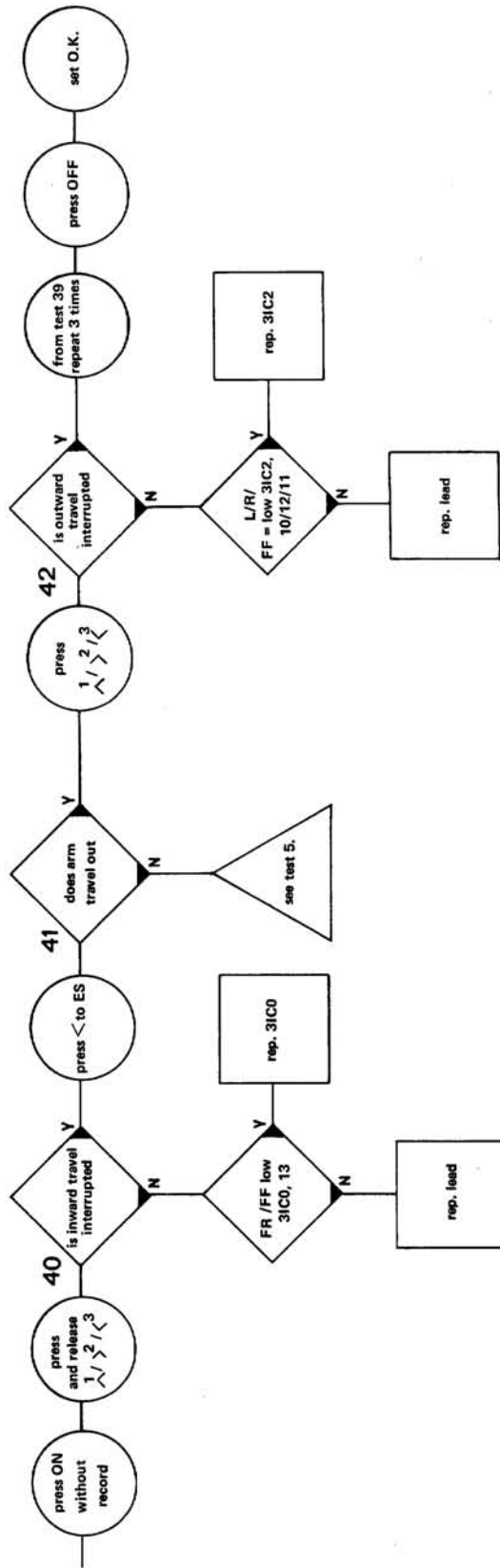

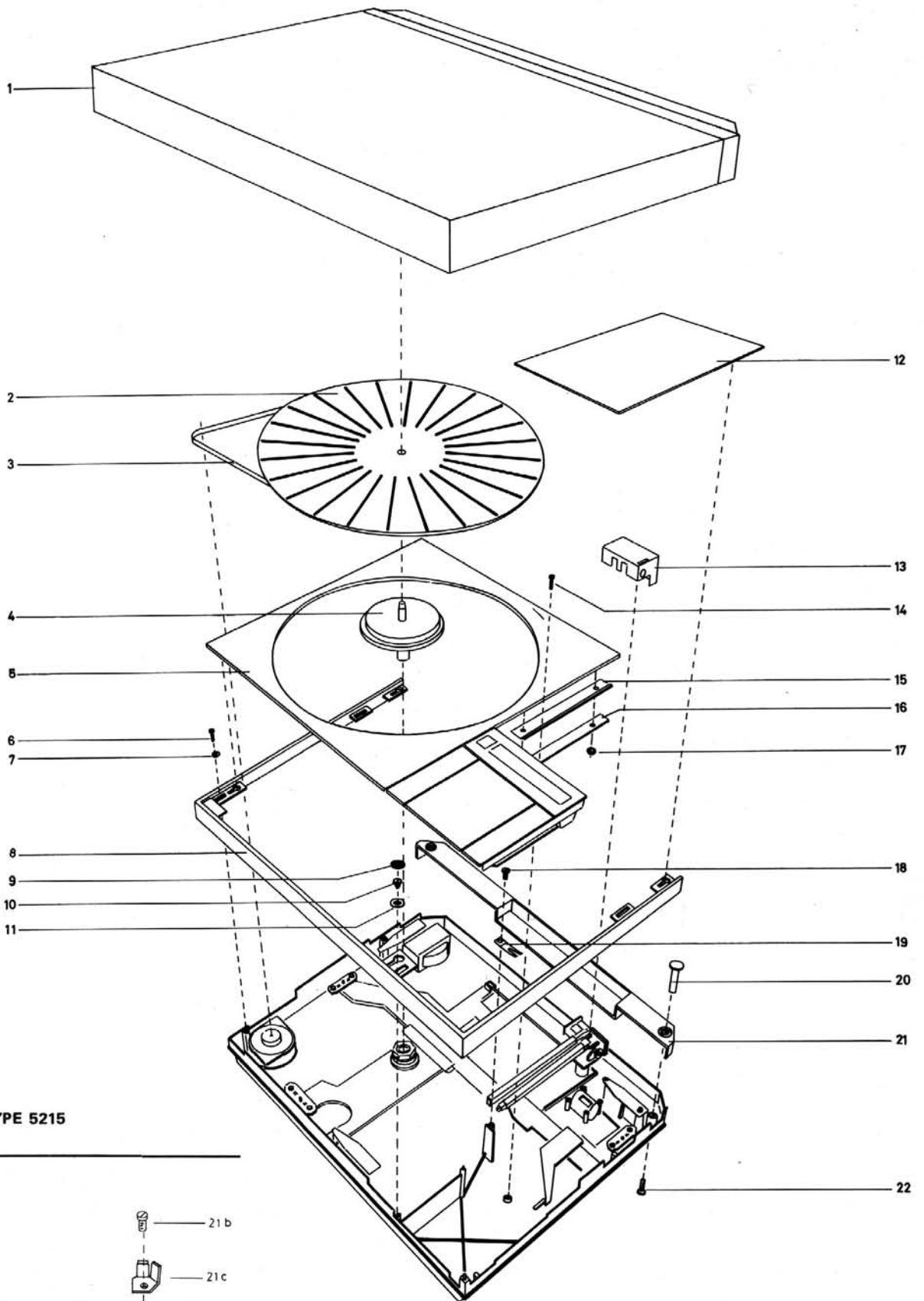

BEOGRAM 4000, TYPE 5215
Correct on page 6-1

Guide for back piece

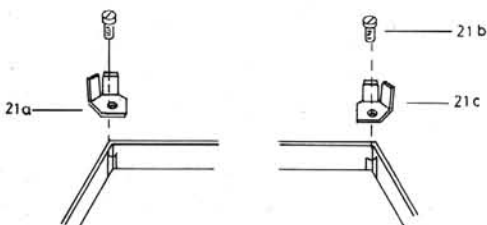

21a	Angle	3014028
21b	Screw	2038207
21c	Angle	3014029

40	3458092	Dial
41	2775224	Pushbutton
42	2775177	Pushbutton
43	2816067	Spring
44	3152063	Circuit board holder
45	8009016	PC board
46	3030021	Holder
47	3151079	Clamp
48	8009015	PC board
49	2038206	Screw AM 3 X 4 DIN 84
50	2834022	Shaft
51	2812040	Spring
52	2775176	Pushbutton
53	3114050	Chassis
	3322034	Mirror
54	2380011	Nut M 3
55	2038206	Screw AM 3 X 4 DIN 84

see page 6 - 6

59	2905045	Bearing
60	2830049	Shaft
61	2038216	Screw AM 3 X 10 DIN 84
62	8009011	PC board
63	2072710	Threaded pin
64	2380094	Nut
65	2042211	Screw, AM 4 X 12 DIN 84
66	3014021	Holder
67	2628005	Spring
68	2381008	Nut
69	2993024	Threaded pin
70	2038233	Screw AM 3 X 20 DIN 84
71	2038214	Screw AM 3 X 8 DIN 84
72	7530008	Solder tag
73	2510089	Clamp
74	2510090	Clamp
75	4200265	El. capacitor
76	4200260	El. capacitor
77	4200259	El. capacitor
78	4200258	El. capacitor
79	2038207	Screw, AM 3 X 5 DIN 84
80	2622041	Washer
81	3114042	Chassis
82	3014022	Belt guide
83	2038239	Screw AM 3 X 35 DIN 84
84 *	8400061	Motor
	2722010	Pulley
	3151117	Mounting hardware
	2038055	Screw AM 3 X 6 DIN 63
	2038208	Screw, AM 3 X 5 DIN 84
85	2938074	Rubber bushing
86	2381007	Nut
87	2628005	Spring
88	8300160	Diode
89	5012011	Resistor
90	7530045	Solder tag
91	3172027	Insulating piece
92	3170047	Mica sheet
93	8320103	Transistor
94	3164027	Cover
95	2034215	Screw AM 2 X 8 DIN 84
96	2038206	Screw AM 3 X 4 DIN 84
97	2938097	Insulating bushing
98	8320266	Transistor
	8320265	Transistor
	8320312	Transistor

BEOGRAM 4000, TYPE 5215

Correct on page 6-4

Pushbutton system

The pushbutton system has been modified so that PC pos. No. 45 is screwed to chassis 53. Also, push-buttons and pins have been modified. This results in the following corrections to the parts list:

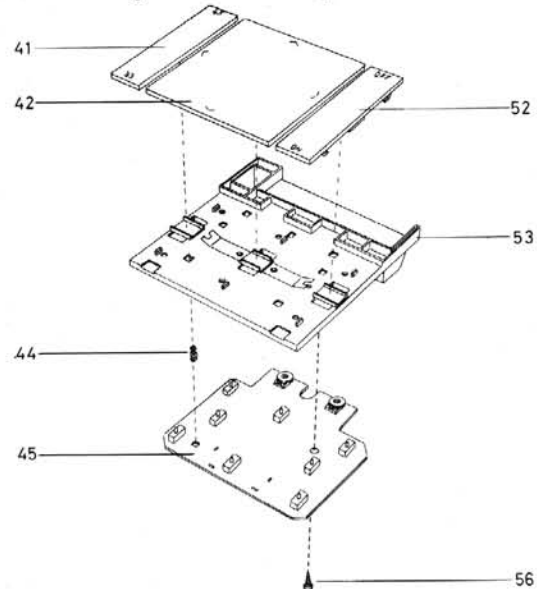

41	Pushbutton	2775275
42	Pushbutton	2775277
44	PC board holder	goes out
52	Pushbutton	2775331
56	Screw	2013209

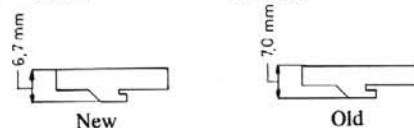

NOTE: New and old parts constitute a whole.

BEOGRAM 4000, TYPE 5215

Correct on page 6-4

Mirror, pushbutton chassis

In order to secure better fastening of the mirror, two angles have been introduced which are glued on.

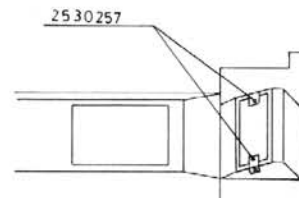

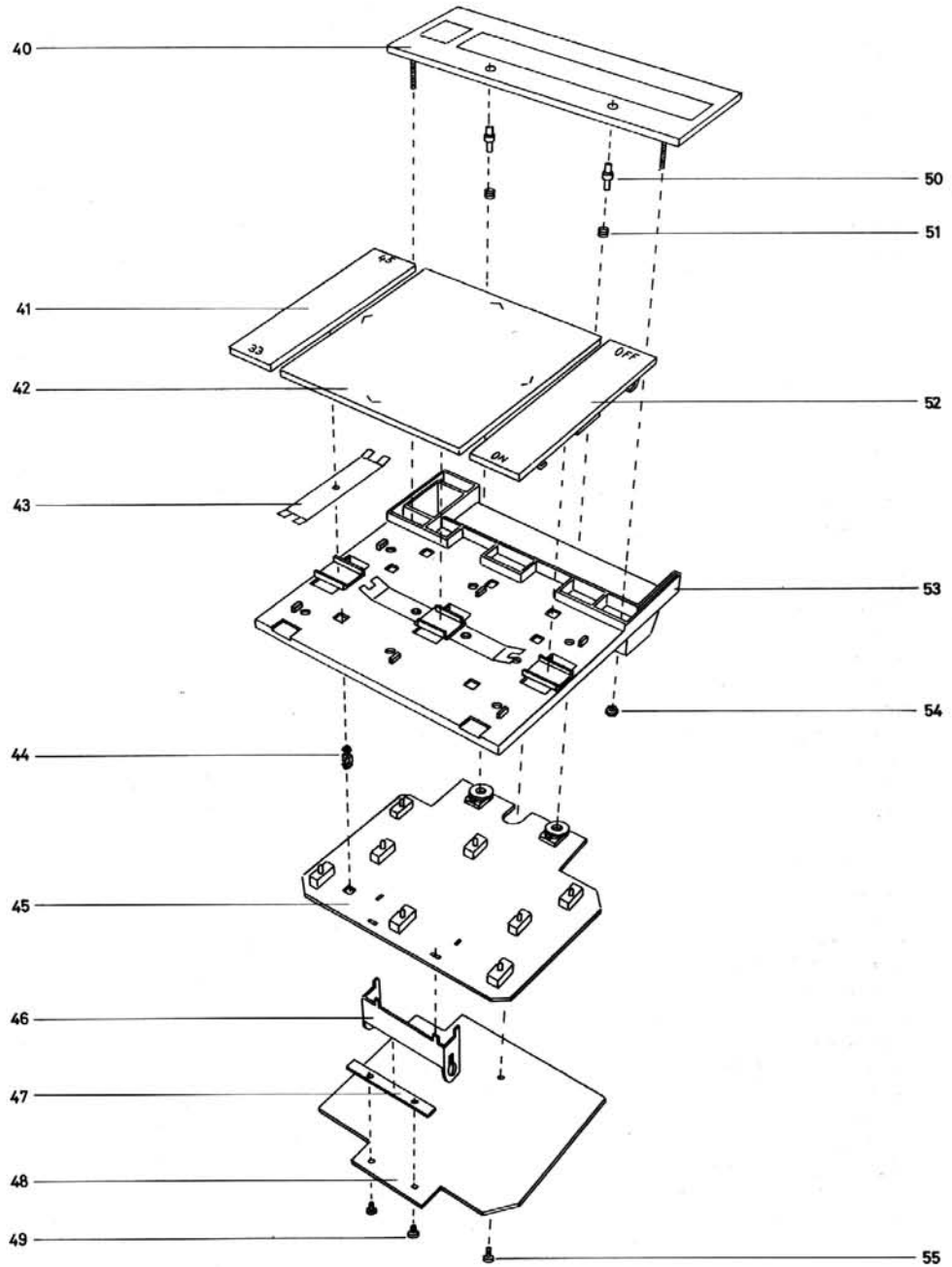

BEOGRAM 4000, TYPE 5215

Correct on page 6-4

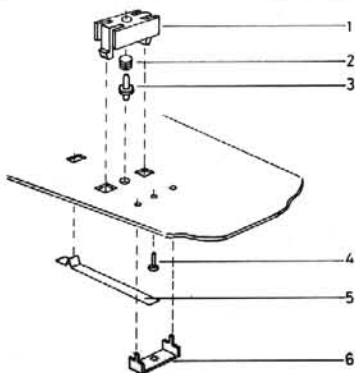

Pos.	33	FF	45	S	L	ON	FR	OFF
1.	3152068	3152068	3152068	3152068	3152068	3152068	3152068	3152068
2								
3	7500067	2992051	7500067	2992052	7500067	7500067	2992051	7500067
4		2364024		2364024			2364024	
5	7500051	7500051	7500051	7500051	7500051	7500051	7500051	7500051
6	7500061	7500050	7500061		7500061	7500061	7500050	7500061

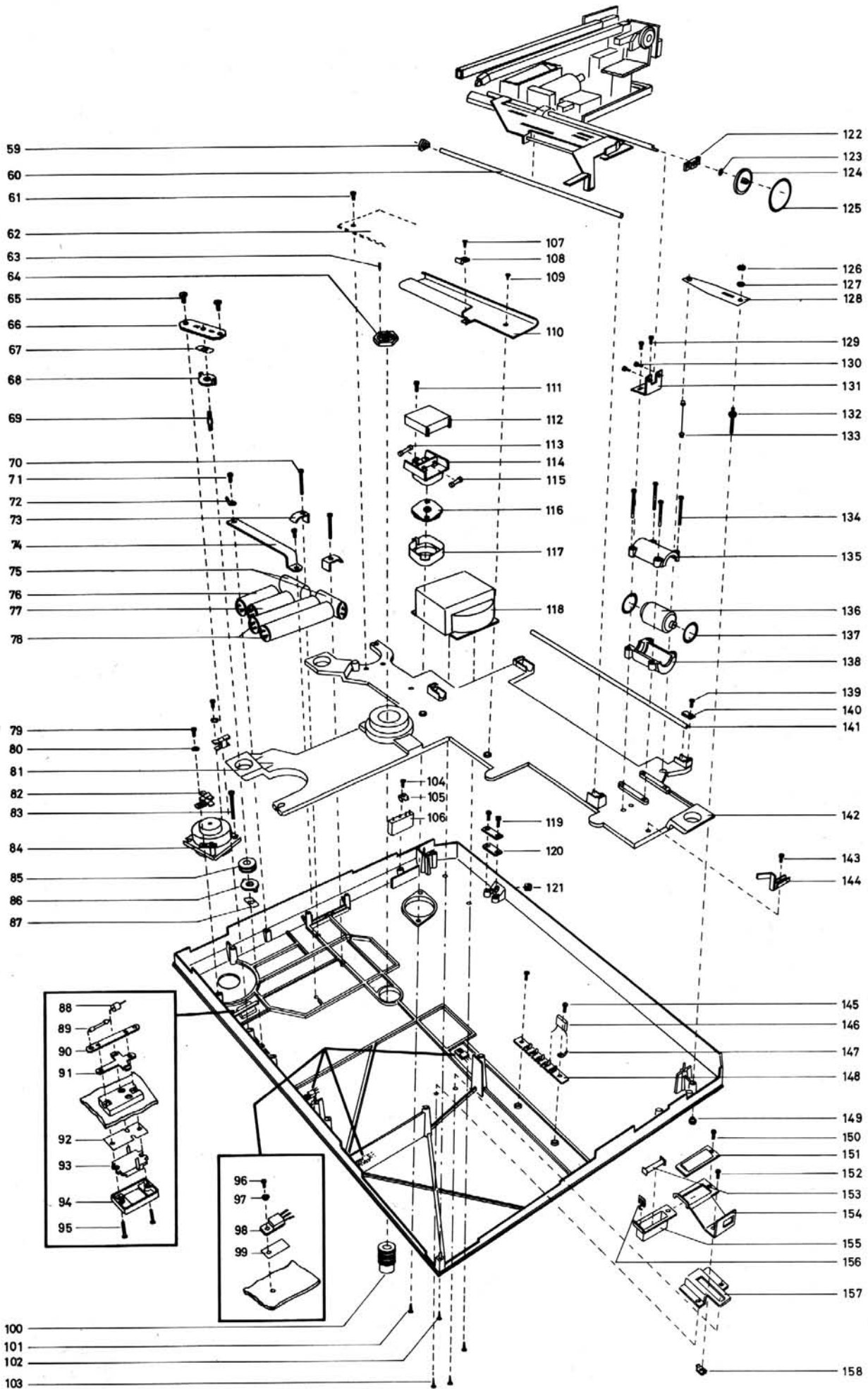

beginning on page 6 - 4

99	3170121	Mica sheet
100	2905046	Bearing
101	2013012	Screw 2,84 X 12,7 ART 4260
102	2013002	Screw ART 4260 2.84 X 6.35
103	2038055	Screw AM 3 X 6 DIN 63
104	2038209	Screw AM 3 X 6 DIN 84
105	2574043	Bracket
106	8310020	Rectifier B 80 C 2200
107	2013200	Screw Art 4261 2.84 X 6.35
108	2510091	Lead holder
109	2013002	Screw Art 4260 2.84 X 6.35
110	3013017	Lead holder
111	2038214	Screw AM 3 X 8 DIN 84
112	3164109	Cover
	3180607	Sticker
113	6600000	Fuse
114	3131060	Fuscholder
115	6600000	Fuse
116	7401001	Mains-voltage switch
117	3131050	Housing
118	8013107	Mains transformer
119	2038216	Screw AM 3 X 10 DIN 84
120	0287155	Clamp
121	2938077	Rubber bushing
122	2905034	Bearing
123	2620027	Washer
124	2722008	Pulley
	2070701	Threaded pin
	2380068	Nut
125	2732016	Belt
126	2380016	Nut
127	2622022	Washer
128	2816081	Spring
129	2038206	Screw AM 3 X 4 DIN 84
130	2038206	Screw AM 3 X 4 DIN 84
131	2530253	Bracket
132	2072914	Screw
133	3955022	Suspension
134	2038235	Screw AM 3 X 25 DIN 84
135	3131048	Housing
136	8400062	Motor
	2722005	Pulley
137	2732015	Rubber disc.
138	3131048	Housing
139	2038216	Screw AM 3 X 10 DIN 84
140	2644003	Clamp
141	2830045	Shaft
142	3114042	Chassis
143	2038206	Screw AM 3 X 4 DIN 84
144	2542295	Bracket
145	2038208	Screw, AM 3 X 5 DIN 84
146	4130087	Capacitor
147	7530005	Solder tag
148	7536025	Tagstrip
149	0585018	Plastic foot
150	2038249	Screw AM 3 X 8 DIN 84 nylon
151	3375017	Cover
152	2038208	Screw, AM 3 X 6 DIN 84
153	8230038	Neon lamp
154	3151092	Holder
	3322035	Mirror
155	3131058	Housing for neon lamp
156	7500064	Contact spring
157	3151090	Holder
158	2389030	Nut

BEOGRAM 4000, TYPE 5215

Correct on page 6-7

Servobelt

As from unit No. 157700, a triangular belt has been introduced instead of the previous round one.

This results in the following corrections to the parts list:

124	Pulley	2722015
125	Belt	2732032
136	Pulley	2722016

The belt and pulleys constitute a whole.

Holder for neon lamp (154)

Two mouldings as shown by the sketch have been introduced in current production. They are glued on.

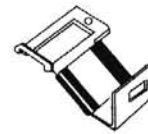

Moulding

3950229

Disc bearing (tiltable)

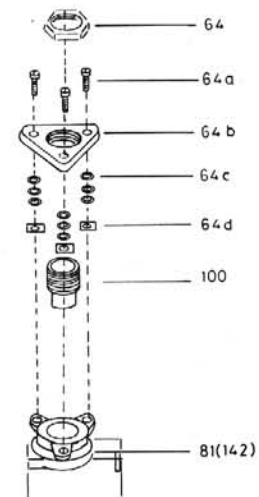

64	Nut	2380096
64a	Screw	2038216
64b	Cap	2641076
64c	Washer	2624027
64d	Plastic spire	2390020
100	Bearing	2905046
81	Chassis	3114066

Washers 64c should be mounted as shown by the sketch.

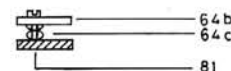

124	Pointed screw	2072921
-----	---------------	---------

Correct on page 6-7 to be continued on page 6-8

Motor with topmounting

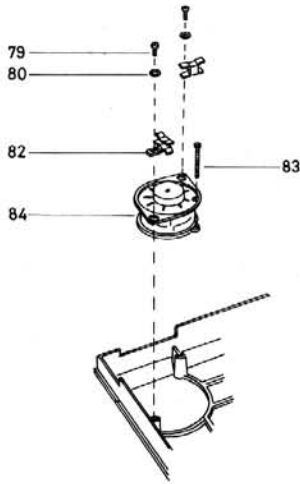

- 79 2038207 Screw, AM 3 X 5 DIN 84
- 80 2622041 Washer
- 82 3014022 Belt guide
- 83 2038239 Screw, AM 3 X 35 DIN 84
- 84 8400046 Motor
- 2722007 Pulley

Not shown parts

- 6271048 Mains lead
- 6270010 Pickup cable with plug
- 3535024 Instruction diagram
- 3391384 Outer carton
- 3391385 Top/bottom inserts
- 3397157 Packing, foam insert, lid
- 3397158 Packing, gable insert, left
- 3397159 Packing, gable insert, right

BEOGRAM 4000, TYPE 5215
Correct on page 6-7

Transformer

- 118 Transformer 8013131
- 214 PC unit 8009013

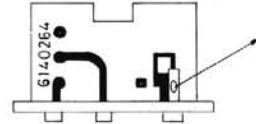

PC unit belonging to transformer 8013107: When



substituting transformer 8013131 it is necessary to replace PC unit 8009013. See sketch.

Drive motor

- 84 Drive motor with mounting bushings 8400061
- Drive motor less bushings 8400066

Both motors are equipped with drive bushing 2722010

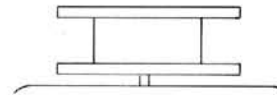

82 Belt guide goes out

BEOGRAM 4000, TYPE 5215
Correct on page 6-8

Drive motor

When replacing motor 8400046 with motor 8400061, a 20 mm dia. hole must be drilled in the bottom to accommodate the shaft and bottom bearing.

After having installed the motor, affix sticker 3180632 over the hole in the bottom.

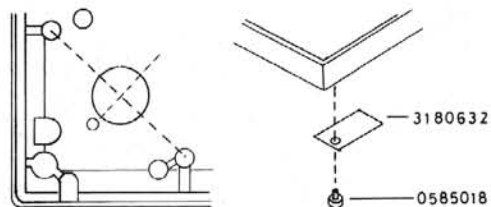

beginning on page 6-9

220	8009014	PC board
	7500051	Contact spring
	2364024	Rivet
221	2389031	Nut
222	2038208	Screw, AM 3 X 5 DIN 84
223	3152074	Holder
224	2993025	Spindle
225	2038206	Screw AM 3 X 4 DIN 84
226	2622041	Washer
227	2830046	Shaft
228	2390004	Circlip
229	3190053	Pointer
230	2644010	Cover
231	2812040	Spring
232	2798003	Eccentric
233	2819061	Spring
234	2851062	Arm
235	2812041	Spring
236	2390004	Circlip
237	2894029	Shaft
238	2802023	Washer
239	2038233	Screw AM 3 X 20 DIN 84
240	2072705	Threaded pin
241	2034231	Screw AM 2 X 4 DIN 84
242	2854023	Arm
243	2390004	Circlip
244	3342020	Counterweight
245	3152089	Holder
246	2390046	Circlip
247	2070400	Threaded pin
248	3150032	Bearing holder
	2900003	Ball bearing
	2622168	Washer
	2812036	Spring
	2390047	Circlip
249	2700008	Adjustment bearing
250	2834038	Shaft
251	2831015	Shaft
252	2361018	Locking pin
253	2622167	Washer
254	2038206	Screw AM 3 X 4 DIN 84
255	3131059	Damper cylinder
256	2038222	Screw AM 3 X 14 DIN 84
257	3164112	Cover
258	2854024	Diaphragm arm
259	2013203	Screw 2.84 X 12.70 ART 4261
260	3131052	Housing
	5210004	Fotoreistor
261	3151085	Holder
262	2038946	Screw
263	2794029	Roller
264	2622041	Washer
265	2038208	Screw, AM 3 X 5 DIN 84
266	2798003	Eccentric
267	3114046	Chassis
	3180536	Sticker for transport screw
	2038946	Screw
	2620028	Rubber disc
268	2625003	Tooth-lock washer
269	2380016	Nut
270	2510086	Bracket
271	6140272	PC board
272	2038206	Screw AM 3 X 4 DIN 84

BEOGRAM 4000, TYPE 5215

Correct on page 6-10

Pick-up arm

The pick-up arm has been modified so that the leads from the pick-up socket are soldered directly to the PC on pick-up arm holder 245.

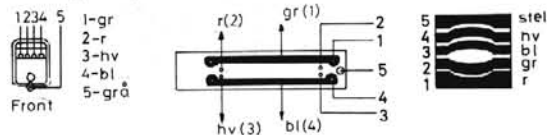

206	Pick-up arm, assembled	2850073
244	Counterbalance weight	3342030
245	Holder	3152160

When replacing pick-up arm 2850052 with pick-up arm 2850073, counterbalance weight 3342020 must be replaced with counterbalance weight 3342030.

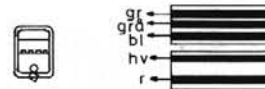

BEOGRAM 4000, TYPE 5215

Correct on page 6-10

Stylus force spring (250)

The stylus force adjustment mechanism has been modified so that the shaft, spring, and gearwheel are mounted without use of glue. The mechanism is supplied in kit form under index No. 2834041.

Leads, pick-up arm

248	Wire bundle (copper wire)	6300059
-----	---------------------------	---------

Arm 234, adjustable

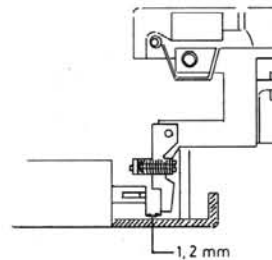

234	Arm complete	2851083
234a	Screw	2034219
234b	Spring	2812065

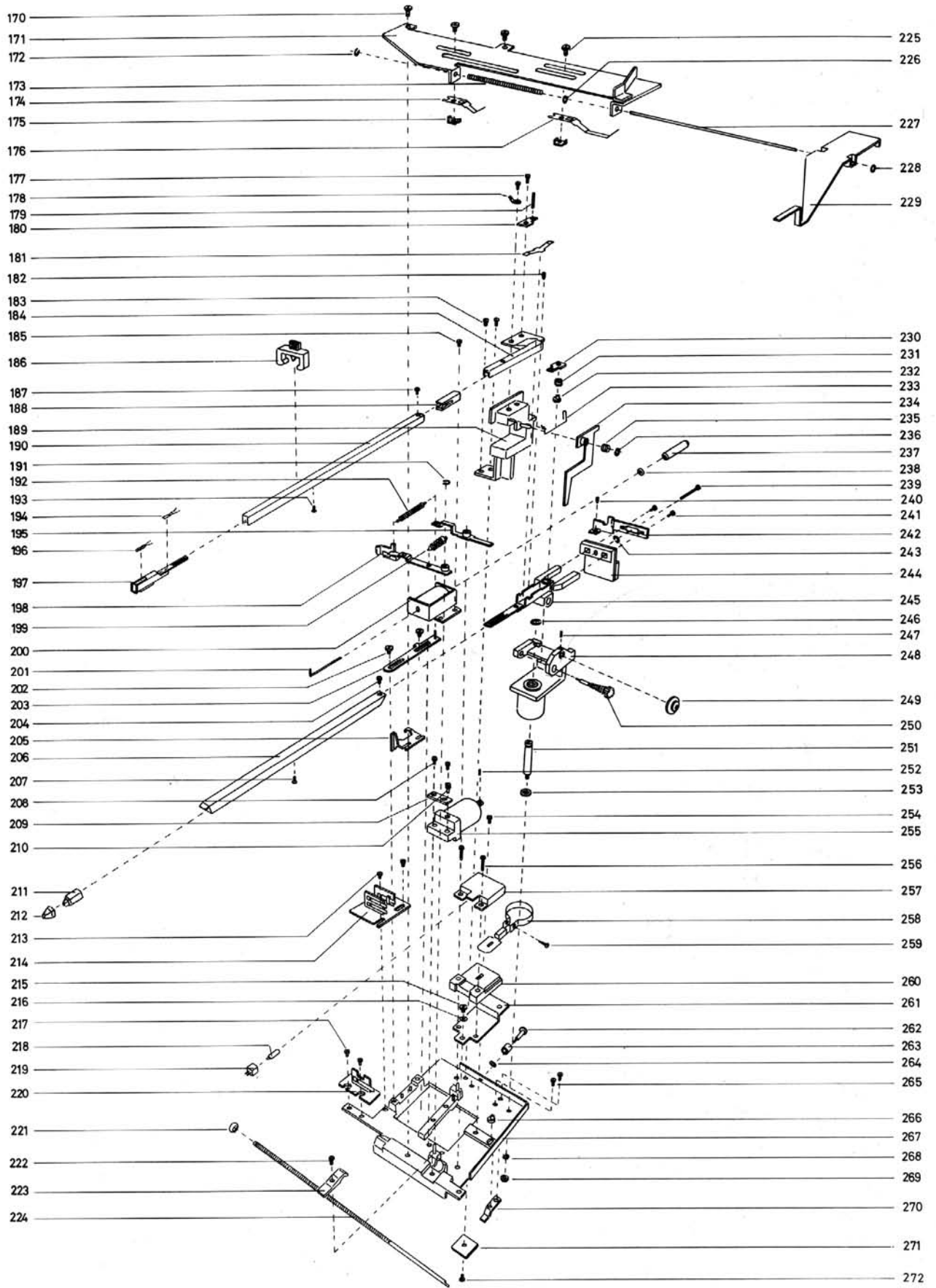

SERVICE TIPS

Demontering og montering af trykknop

Dismounting and mounting of pushbutton

Demontierung und Montierung vom Druckknopf

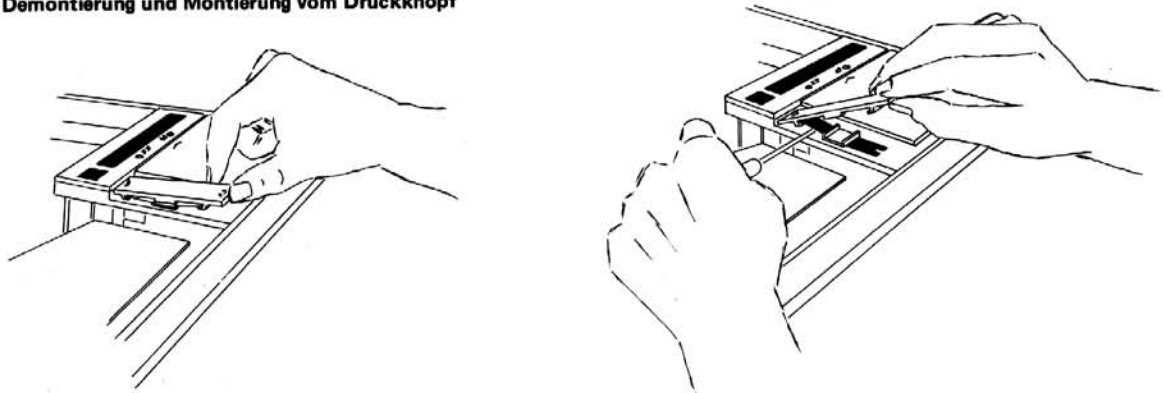

Demontering af slæde

Dismounting of slide

Demontierung vom Schlitten

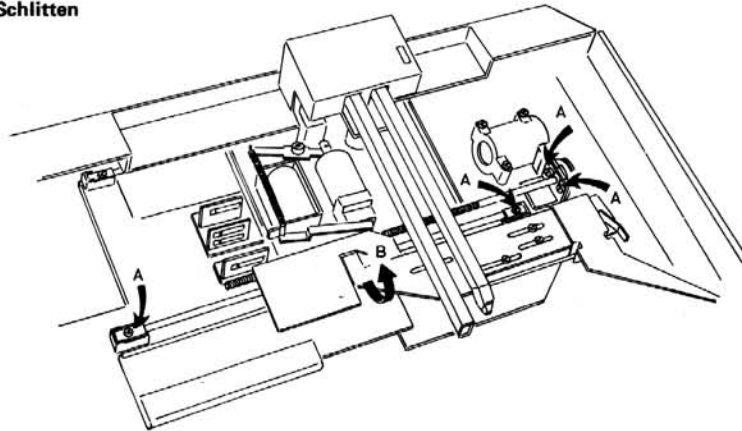

Ledningsmontering i pick-up arm

Mounting of cable in the pick-up arm

Montierung einer Leitung im Tonabnehmerarm

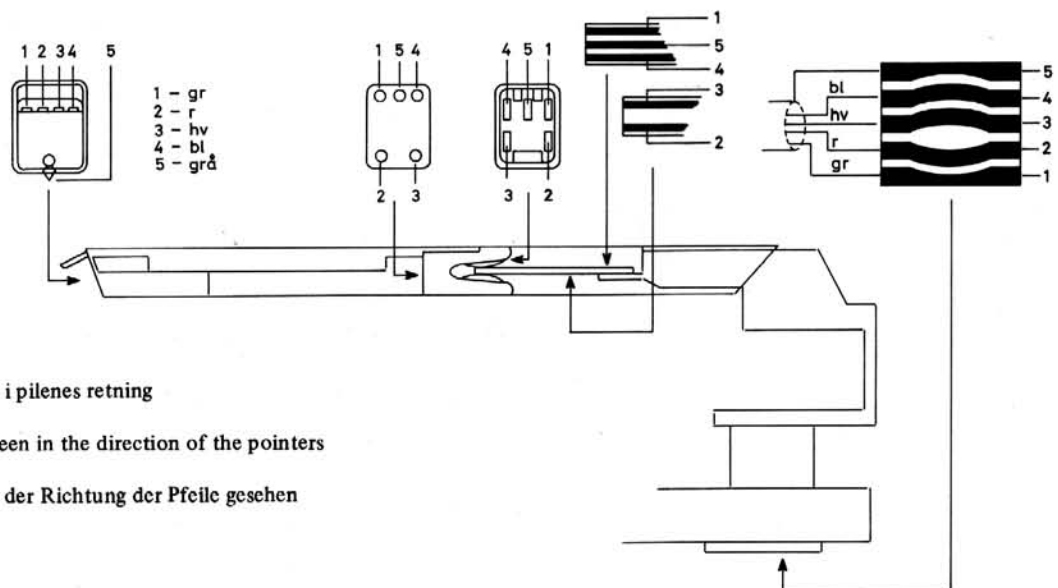

Skitser set i pilenes retning

Sketches seen in the direction of the pointers

Skizzen in der Richtung der Pfeile gesehen



technical information

ISSUE NO. BG1.

GLOUCESTER

2ND JANUARY 1974

BEOGRAM 4000

Servo system adjustment.

The sensitivity of the servo system corresponding to 15-19 record grooves deviation away from the record centre has until now, been adjusted by pushing the diaphragm up and down, which varies the amount of light falling on the photo resistors. This adjustment has become difficult because of tolerances in the sensitivity of the photo resistors and the light output of the bulb.

In order to overcome this a potentiometer of 100 Ω has been put in series with the lamp OIL1; this adjusts the brightness of the bulb and therefore the sensitivity of the servo system.

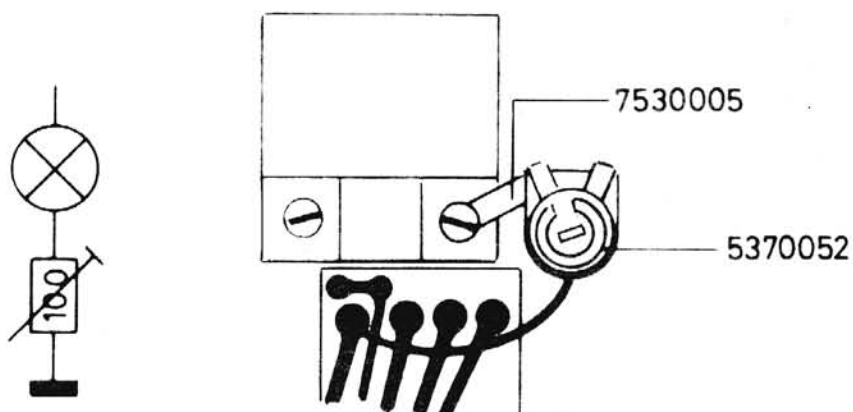



technical information

ISSUE NO. BG2.

GLOUCESTER

2ND JANUARY 1974

BEOGRAM 4000 Type 5215

Servo drive belt

Because of difficulties in supply of the original round belt, a triangular belt has been introduced. This gives the following corrections to the parts lists:

Pos.	124	Pulley	2722015
Pos.	125	Belt	2732032
Pos.	136	Pulley	2722016

When replacing the earlier belt or pulley all three parts mentioned above must be replaced at the same time due to differences in design.

The modification has been introduced in production from S.N. 157700.

* * * * *



technical information

ISSUE NO. BG3.

GLOUCESTER

6TH MAY, 1974

BEOGRAM 4000 Type 5215

Detector arm circuit

In order to improve the life expectancy of the lamp in the detector arm, a new bulb is used, part number 8230047. Since this lamp has a lower consumption and light output than its predecessor it has been necessary to make minor changes to the BL and DR circuits.

BL circuit

The lower lamp consumption can result in insufficient voltage being developed across 1R30 to operate 1TR12 reliably. Therefore, 1R30 is changed from 15 ohms to 22 ohms, part number 5011004.

DR circuit

Since the new lamp has less intensity it is necessary to remove the 50K potentiometer mounted on the print side of the PW board. This, it will be remembered, was installed to give a measure of control over the sensitivity of the DR circuit for dealing with semi-transparent records and is not shown in the circuit diagram.

* * * * *