

TAPE RECORDER

SERVICE INFORMATION FOR THE

PHILIPS

EL3302A/15

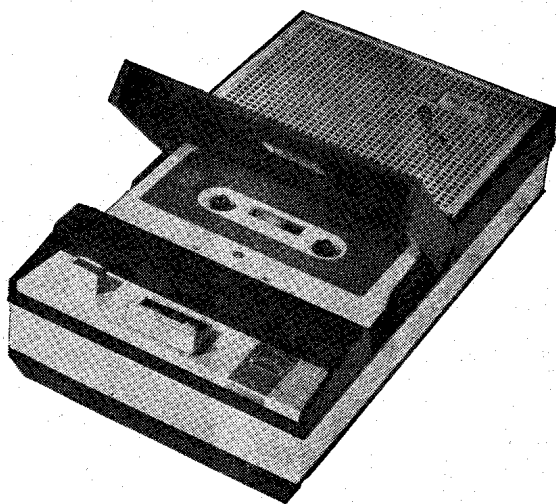

Stella

ST473

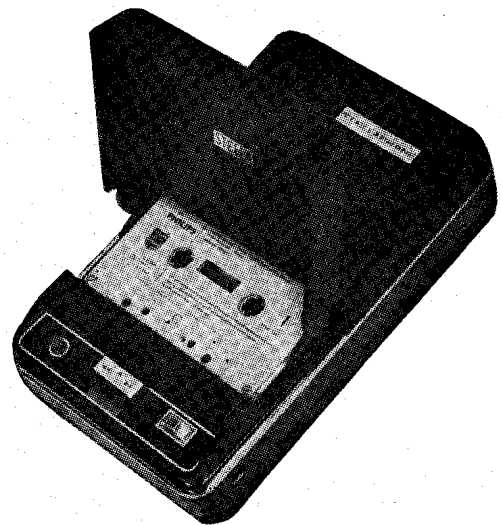

CES 

COMBINED ELECTRONIC SERVICES LIMITED

QUEENSWAY · WADDON FACTORY ESTATE · CROYDON · CR9 · 4DR

TELEPHONES:

Spare part orders: 01-686 7311

General Service enquiries: 01-688 7722

After business hours: Recorded messages on both lines

TELEX: 262308

CONTENTS

	Page No.
A — INTRODUCTION	1
B — SPECIFICATION	1
C — ACCESSORIES	1
D — OPERATION	3
E — DISMANTLING	3
F — MECHANICAL DESCRIPTION	4
G — MECHANICAL REPLACEMENTS AND ADJUSTMENTS	4
H — CLEANING AND LUBRICATION	6
I — ELECTRICAL DESCRIPTION OF MOTOR CONTROL CIRCUIT	10
J — ELECTRICAL CHECKS AND ADJUSTMENTS	10
K — MICROPHONE AND REMOTE CONTROL UNIT	10
L — CASSETTE ASSEMBLY	10
M — SPARE PARTS LIST	14

A — INTRODUCTION

The above two models are compact, portable, battery operated, cassette tape recorders, employing 10 transistors and 3 diodes. Both models are electrically identical and differ only in cabinet presentation.

The EL3302A/15 is supplied complete with carrying case, microphone with detachable remote control unit, a connecting lead and a pre-recorded demonstration tape cassette.

The ST473 is supplied with a microphone incorporating a built-in remote control switch, a connecting lead and a pre-recorded demonstration tape cassette. No carrying case is provided, a shoulder strap, combined with the microphone and remote control switch leads, being clipped onto the sides of the recorder.

B — SPECIFICATION

Recording/Playback system	Twin track monophonic, left to right
Tape width	0.15 ins.
Tape speed	1½ i.p.s. (4.75 cm/s.)
Tape loading	Philips compact cassette system
Playing time	2×30 mins. with C-60 cassette 2×45 mins. with C-90 cassette
Fast wind/rewind time	70 secs., approx. with C-60 cassette
Frequency response	80-10,000 Hz. ±6dB
Signal to noise ratio	Better than 45dB
Wow and flutter	±0.4%
Output power	400mW
Loudspeaker	High efficiency 2½" circular
Mod. level/bty. indicator	Moving coil meter
Battery supply	5×1½V (U11 or equivalent)
Battery life	Approx. 18 hrs. with 'Long Life' batteries

Microphone:

EL3302A/15	EL3797/50
ST473	EL1974/13
Connecting lead (see para. D.1)	EL3768/03

Transistors and diodes	T1	AC125
	T2	AC125
	T3	AC125
	T4	AC126
	T5	AC126
	T6	AC128
	T7	AC127
	T8	AC125
	T9	AC127
	T10	AC128
	X1	BA114
	X2	BA114
	X3	BA114

Input/output sockets

Input:	Skt1—Microphone	Pins 1/4 and 2—0.3mV into 2KΩ
	Skt1—Radio/P.U./2nd tape recorder	Pins 1/4 and 2 (via connecting lead EL3768/03) —225mV via 1.5MΩ
	Skt2—External mains supply unit	Pins 3 and 1/2
	Skt2—Remote stop/start unit	Pins 5 and 1/2
Output:	Skt1—Ext. amplifier/tape recorder	Pins 3/5 and 2—0.5V across 20KΩ
	Skt2—Headphones	Pins 4 and 1/2—200mV across 1.5KΩ
	Skt3—Ext. loudspeaker	400mW into 5-8Ω impedance

Presentation—EL3302A/15

Black, texturised polystyrene cabinet with brushed silver centre band and control escutcheon. Matt silver grille with polished surround. The carrying case, which has a black grained finish with silver trim, provides storage space for microphone, remote stop/start switch and microphone table stand.

Dimensions	Recorder	7¾"×4½"×2¼"
	Carrying case	8¼"×6½"×2½"

Weight	4lb. (including carrying case and batteries)
---------------	--

Presentation—ST473

Weather-proof cabinet constructed in black polystyrene plastic with chromium plated trim. The shoulder strap is adjustable in length and is integral with the microphone and remote stop/start switch connecting leads.

Dimensions	8"×4¾"×2½"
Weight	3lb. (including batteries)

C — ACCESSORIES

(not supplied with recorder)

Stethoscope headphones	EL3775/85
Mains supply unit	EL1998 or N6501
Connection box/extension lead for mic.	EL3962/02
Connection lead (DIN plug at both ends)	EL3768/14

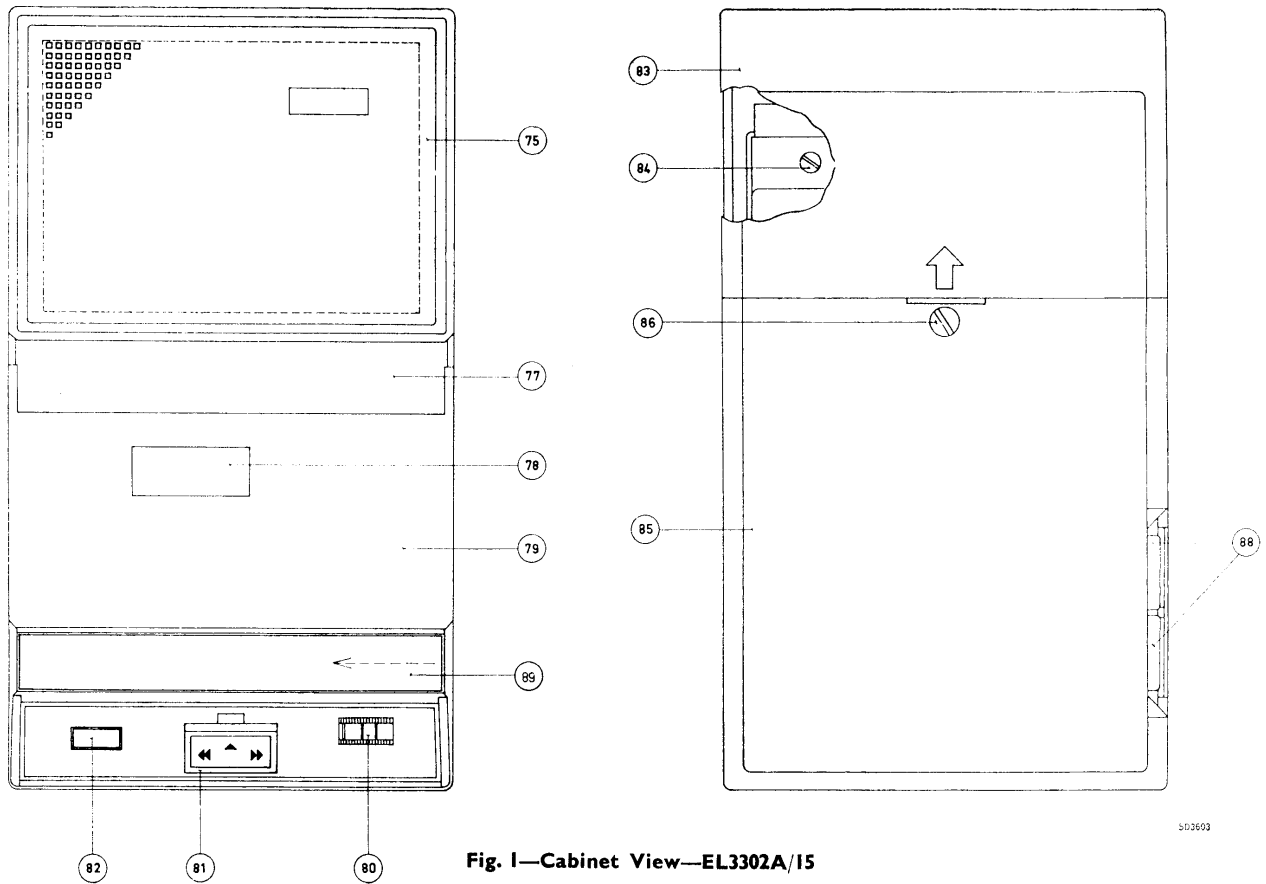

Fig. 1—Cabinet View—EL3302A/15

503603

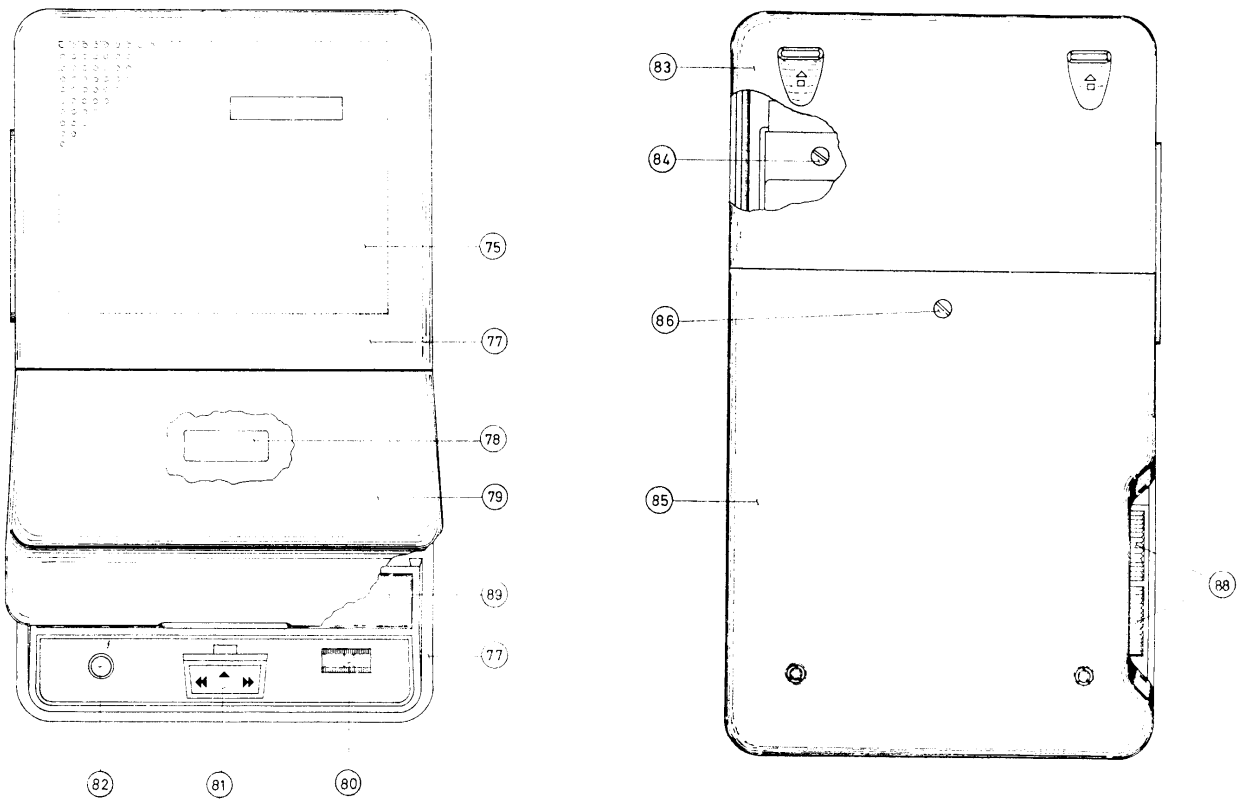

Fig. 2—Cabinet View—ST473

503604

D — OPERATION

Detailed operating instructions are supplied with each recorder.

1. Record (see Figs. 1 and 2)

Hold down red record button 82 and push tape transport knob 81 forward. Adjust modulation control (foremost knob) so that the indicator pointer of the meter almost reaches the red segment during the loudest passages. On completion of recording, pull the tape transport knob backwards. When recording from an input source other than the microphone, it may be necessary to include some form of attenuation in the input lead to prevent overloading of the input stage and consequential distortion. The connecting lead supplied with the recorder, type EL3768/03, incorporates a 1.5MΩ series resistor. The value of this resistor may be altered, under certain conditions, to provide a satisfactory recording.

The lead connections are: Red—recording input; White—line output and Black—common earth (screening)—see Fig. 3.

To ensure that a particular recording cannot be accidentally erased, two knockout lugs, which are moulded in the rear of the cassette, can be removed. If the left-hand knock-out is removed for the track in use, the record button is locked and cannot be depressed, thus the recorder cannot be switched to 'Record'.

2. Playback

Push tape transport knob 81 forwards and adjust the volume control (rear-most knob) to the required sound level. To stop playback, pull the tape transport knob backwards.

3. Forward wind and Rewind

Move the tape transport knob to the left or right, as required.

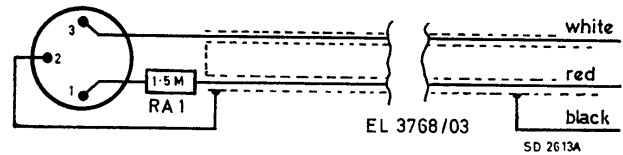

Fig. 3—Radio/Pick-up Connecting Lead

E — DISMANTLING

1. Cabinet removal (see Figs. 1 and 2)

Remove the cassette, battery cover 83, the batteries and bottom plate 85, then pull off tape transport knob 81. Withdraw the screw located between the turntables and the three screws securing the chassis to the cabinet assembly. The chassis is now free to be withdrawn from the cabinet. Re-assemble in the reverse order.

2. Printed panel removal

Uncase the machine as per para. 1. above; remove the two screws located one at each end of the amplifier panel and the screw securing the volume/mod. level control bracket to the chassis. Free the leads tied down to the chassis, then turn the panel sideways through 90°. The component side of the panel is now accessible to enable repairs to be carried out. The panel may be removed completely by disconnecting various leads from solder tags and switch S4.

When refitting panel, ensure that the end of switch lever 36 engages with the slider of switch S4 (see Fig. 4).

The motor control panel may be detached by removing the two securing screws located one at each end of the panel.

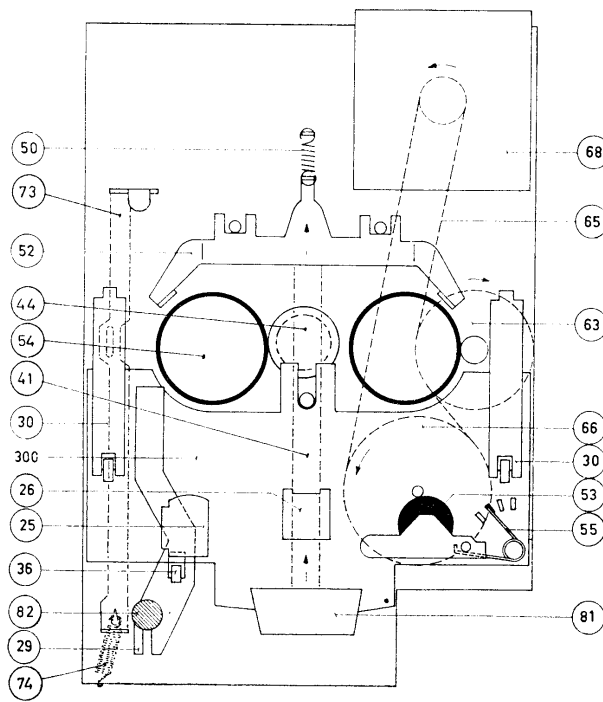

Fig. 4

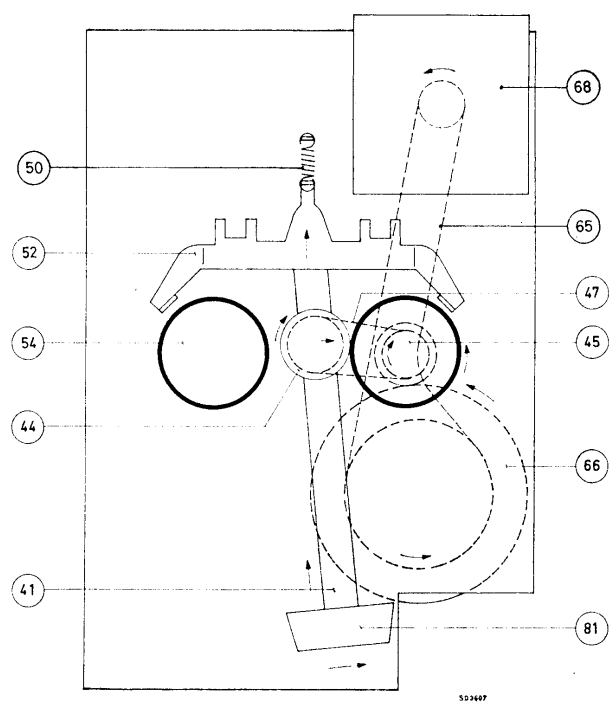

Fig. 5

F — MECHANICAL DESCRIPTION

1. Playback (see Fig. 4)

When tape transport knob 81 is pushed forwards, carriage plate 300 moves erase head 25, record/playback head 26 and pressure roller 53 into contact with the tape. A felt pad in the cassette maintains adequate pressure between the tape and the record/playback head. At the same time tape transport arm 41 pushes switch operating plate 71 (see Fig. 11) onto switch S1 and closes contacts 1-2 and 4-5-8 supplying voltage to the motor and the amplifier.

Motor 68 drives the idler wheel of clutch assembly 63 and flywheel 66 by means of belt 65. When carriage plate 300 moves forwards, it releases clutch pulley 63 and brings it into contact with the R.H. turntable to provide a slipping drive for tape take-up. Winding roller assembly 44 is brought into contact with the L.H. turntable and provides tension to the tape. Tape transport arm 41 releases brake bracket 52, which is held away from the turntables by tension spring 50.

2. Record (see Fig. 4)

All mechanical operations for 'Playback' apply.

The record button cannot be depressed unless record interlock bracket 73 has been moved backwards by the insertion of a cassette on which the moulded knockouts are still intact (see para. D1 above). If this is the case, when record button 82 is depressed, it pushes leaf spring 29 over the end of switch operating lever 36. Thus, when tape transport knob 81 is moved forward, leaf spring 29, attached to carriage plate 300, moves forward and causes switch operating lever 36 to switch S4 to the 'Record' position. S4 is returned to the 'Playback' position when tape transport knob 81 is pulled backwards.

3. Forward wind (see Fig. 5)

When tape transport knob 81 is moved to the right, tape transport arm 41 is moved forwards, releasing brake bracket 52 from the turntables and, via switch operating plate 71, closes contacts 1-2 and 4-5-8 supplying voltage to the motor. Winding roller assembly 44, mounted on tape transport arm 41, comes into contact with the R.H. turntable. Drive pulley 45 is driven by flywheel 66 and drives, via belt 47, winding roller 44.

4. Rewind

For this position tape transport knob is moved to the left. Mechanically the action is the same as for 'Forward wind' above, except that winding roller 44 is brought into contact with the L.H. turntable and contacts 2-3 and 6-7-8 are now closed, reversing the polarity of supply to the motor and hence driving it in the opposite direction.

G — MECHANICAL REPLACEMENTS AND ADJUSTMENTS

1. Replacements (see Fig. 11)

(a) Main drive belt 65

Remove flywheel lower bearing 67 (3 screws) and motor bottom plate 307 (1 screw). The drive belt can now be removed. Replace in the reverse order.

Note: When refitting flywheel lower bearing 67, ensure that the groove in the flywheel is in line with that in the motor pulley, so that the belt runs parallel to the chassis. This can be done by inserting a screwdriver blade in the slot, as shown in Fig. 6, and gently easing lower bearing 67 either up or down as required.

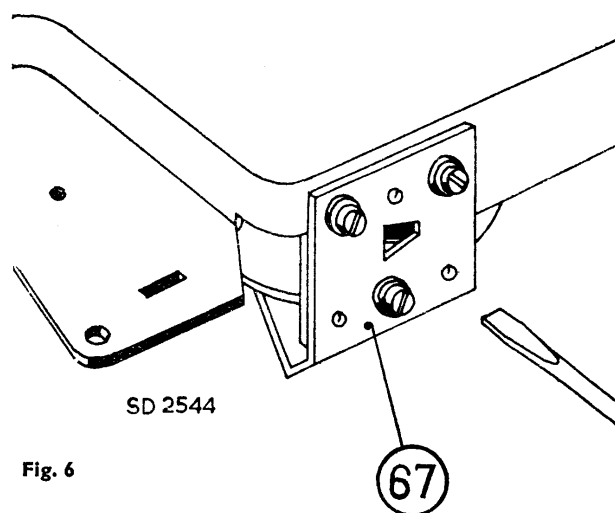

Fig. 6

(b) Flywheel 66 and clutch 63

Remove flywheel lower bearing 67 (3 screws) and free the drive belt from the flywheel. Remove the motor control panel (2 screws) and its support bracket (1 screw underneath mod/bty. meter). Release the nylon circlip securing clutch 63. The flywheel and clutch can now be removed together. Replace in the reverse order, ensuring that the loop of spring 60 is positioned as shown in Fig. 7.

Align the motor and flywheel pulley grooves as described in para. (a) above.

(c) Motor 68

Remove motor bottom plate 307, lift the motor from its screen and disconnect the wires from chokes L1 and L2. Replace in the reverse order.

Note: After replacement of the motor its speed should be checked, as described in para. 2 (g) below.

(d) Turntables 54

Pull off top cap 51 and lift the turntable from its spindle.

(e) Winding roller assembly 44

Remove spring 50 and release bracket 308 by removing the two retaining screws 9; retain leaf spring 57 which is also held by these two screws. Remove the nylon circlip securing winding roller assembly 44, which can now be turned slightly anti-clockwise and lifted from its spindle.

Replace in the reverse order.

2. Adjustments

(a) Pressure roller arm 53 (see Fig. 7)

Switch to 'Playback'. The force required to pull the pressure roller away from the capstan should be 150-190 gms. It can be adjusted by fitting the end of torsion spring 55 into any of the four locating holes.

(b) Clutch 63

To check the internal friction of clutch 63, switch to 'Playback', turn the volume control to minimum, then measure the overall current consumption of the machine. Stop the L.H. turntable from rotating and note the increase in current, which should lie between 7-14mA. If this is not the case, check the adjustment given in para. (c) below. Measure the increase in current again and, if still outside the limits given above, clutch assembly 63 should be replaced.

(c) Clutch spring 60 (see Fig. 7)

Switch to 'Playback'. The force required to pull clutch pulley away from the L.H. turntable at point B, should be 70-100 gms. Adjust by bending spring 60.

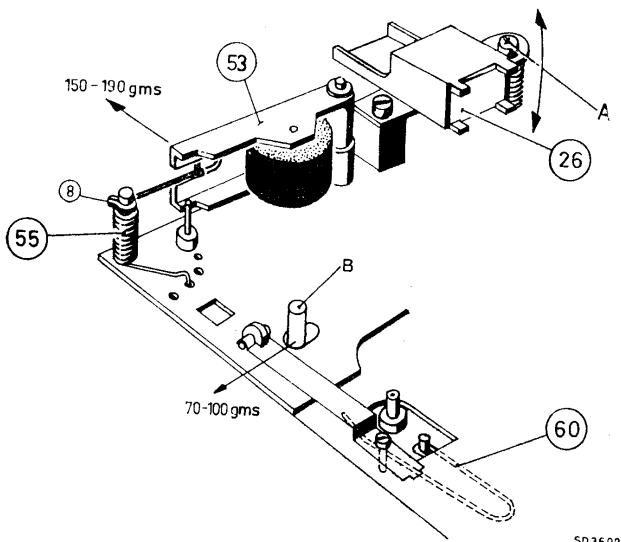

Fig. 7

(d) Brake bracket 52 (see Fig. 11)

In position 'Record' or 'Playback', brake bracket 52 is held against two stop pins on the main chassis by spring 50. The clearance between the brake blocks and the turntables should be at least 0.3 mm. Adjust by bending tag A on bracket 308.

(e) Switch S1

In the 'Off' position a small clearance should exist between all of the switch contacts. Adjustment can be made by slightly repositioning the switch about its securing screw and by bending the contacts.

(f) Winding roller assembly 44 (see Fig. 8)

Switch to 'Playback'. Lug C should just clear projection E; adjust by bending lug C. Spring D should just touch the bottom of the slot in lug B; adjust by bending lug B. The distance between drive roller 45 and flywheel 66 should be 1-2 mm.; adjust by bending tag F.

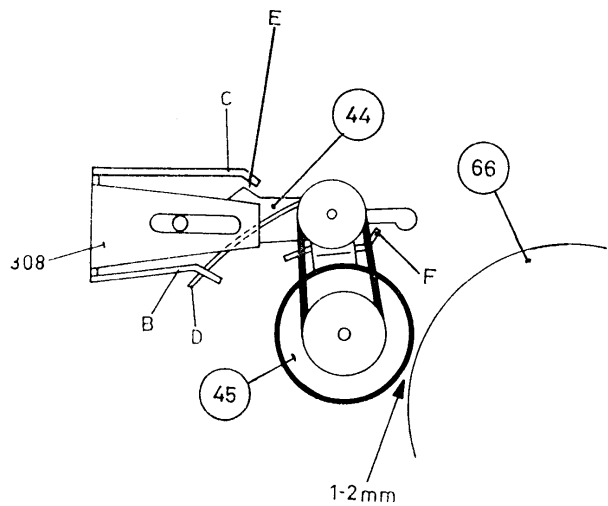

Fig. 8

(g) Motor speed adjustment (see Fig. 9)

To carry out this adjustment, one side of a standard tape cassette must be removed. This can be done with the aid of a knife, the burrs being removed with a small file. The tape speed is checked by pulling a loop of tape from the side of the cassette and holding inside this loop a suitable tape stroboscope. With the recorder set to the 'Playback' position, adjust R54 to obtain the correct speed as indicated by the stroboscope.

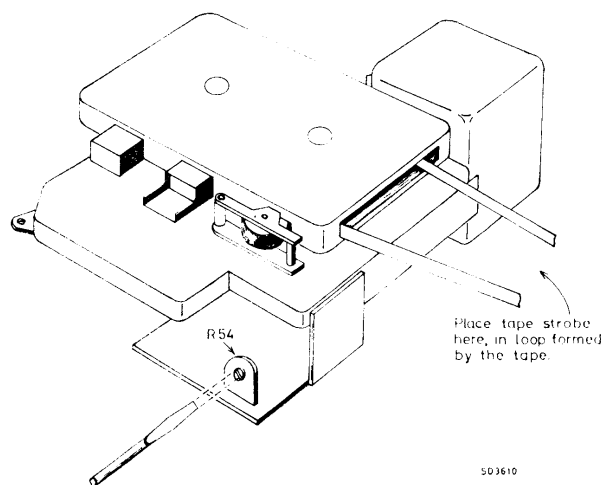

Fig. 9

H — CLEANING AND LUBRICATION

1. Cleaning

(a) Record/playback and erase heads, etc.

The magnetic heads and the capstan should be cleaned at regular intervals. They can be cleaned with a soft cloth wrapped around a wooden stick and moistened with methylated spirits or industrial alcohol. Metal objects should not be allowed to come into contact with the magnetic head faces.

(b) General

After approximately 500 hours of service it is advisable to clean the following parts with methylated spirits or industrial alcohol.

Record/playback and erase head faces

Capstan

All drive belts

Grooves in flywheel and pulleys

All friction drive surfaces

Brake shoes and braking surfaces of turntables

2. Lubrication

All machines are fully lubricated during manufacture and further attention should be normally required only after a long period of

service. If this is the case, or upon replacement of any mechanical component, lubrication may be applied SPARINGLY to the positions described below (also see Fig. 10). It is emphasised that excessive use of lubricant will hinder rather than help the operation of the instrument, and great care should be taken to ensure that none gets onto any of the drive surfaces.

The motor must not be lubricated as the penetration of oil between brush and commutator will considerably reduce its life.

(a) A light oil (Shell Tellus 33) may be applied to the following points:— (see Fig. 10)

Turntable spindles 70.

Shaft of roller 40.

Flywheel spindle 66.

Hub and bearing of clutch 63.

Hub and shaft of pulley 45.

(b) A light grease (Shell Alvania 2) may be applied to the following points:— (See Fig. 10)

Sliding surfaces and grooves of carriage plate 300.

Ball bearings 35 (under carriage plate 300).

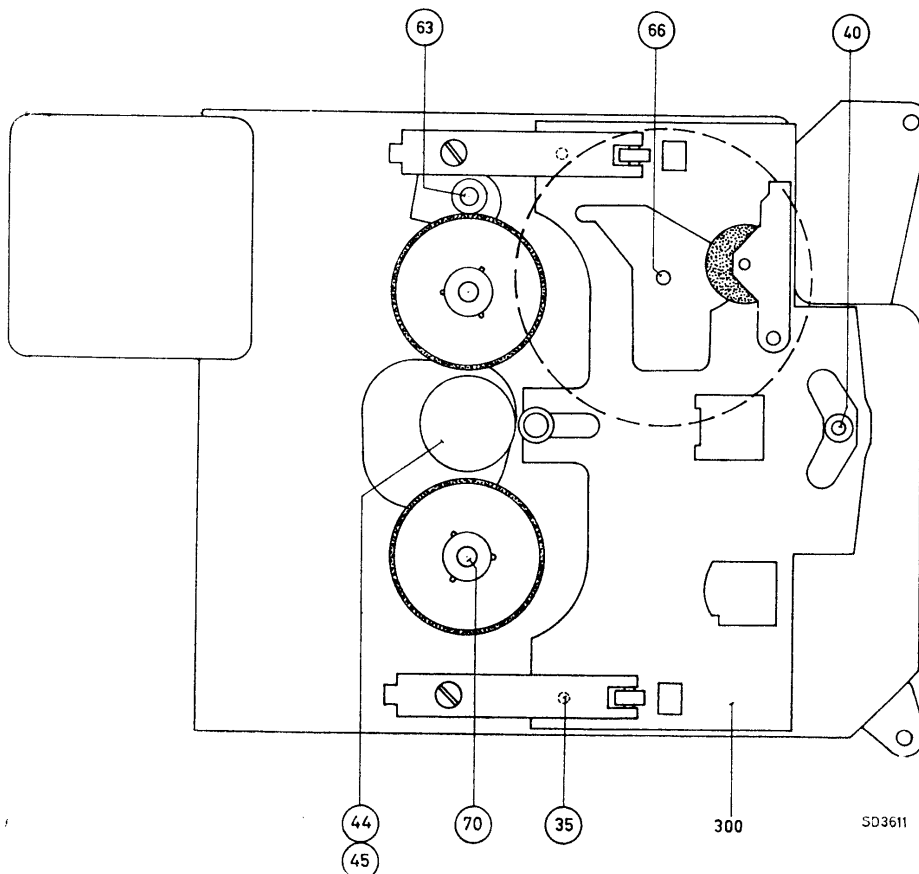

Fig. 10—Lubrication Chart

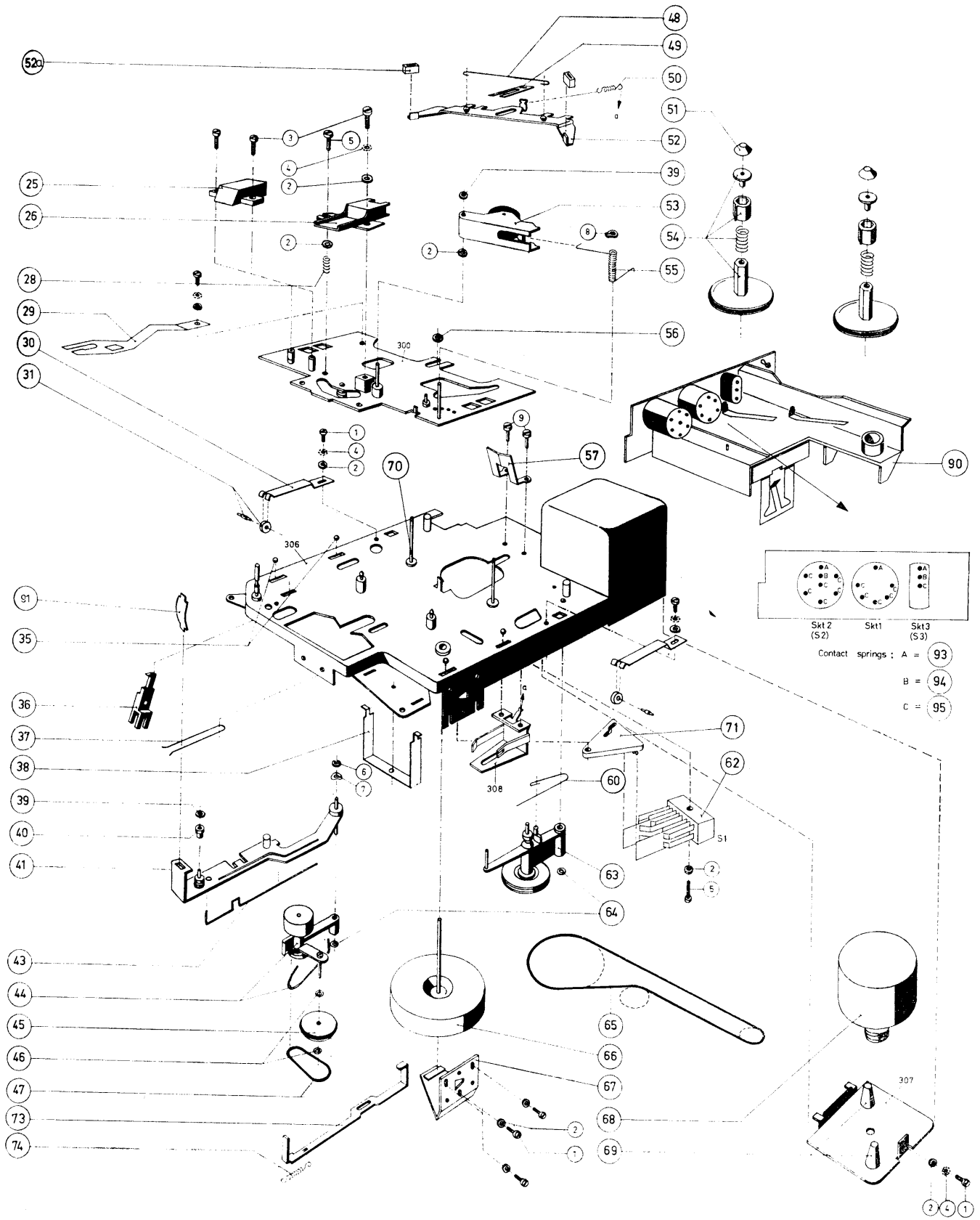
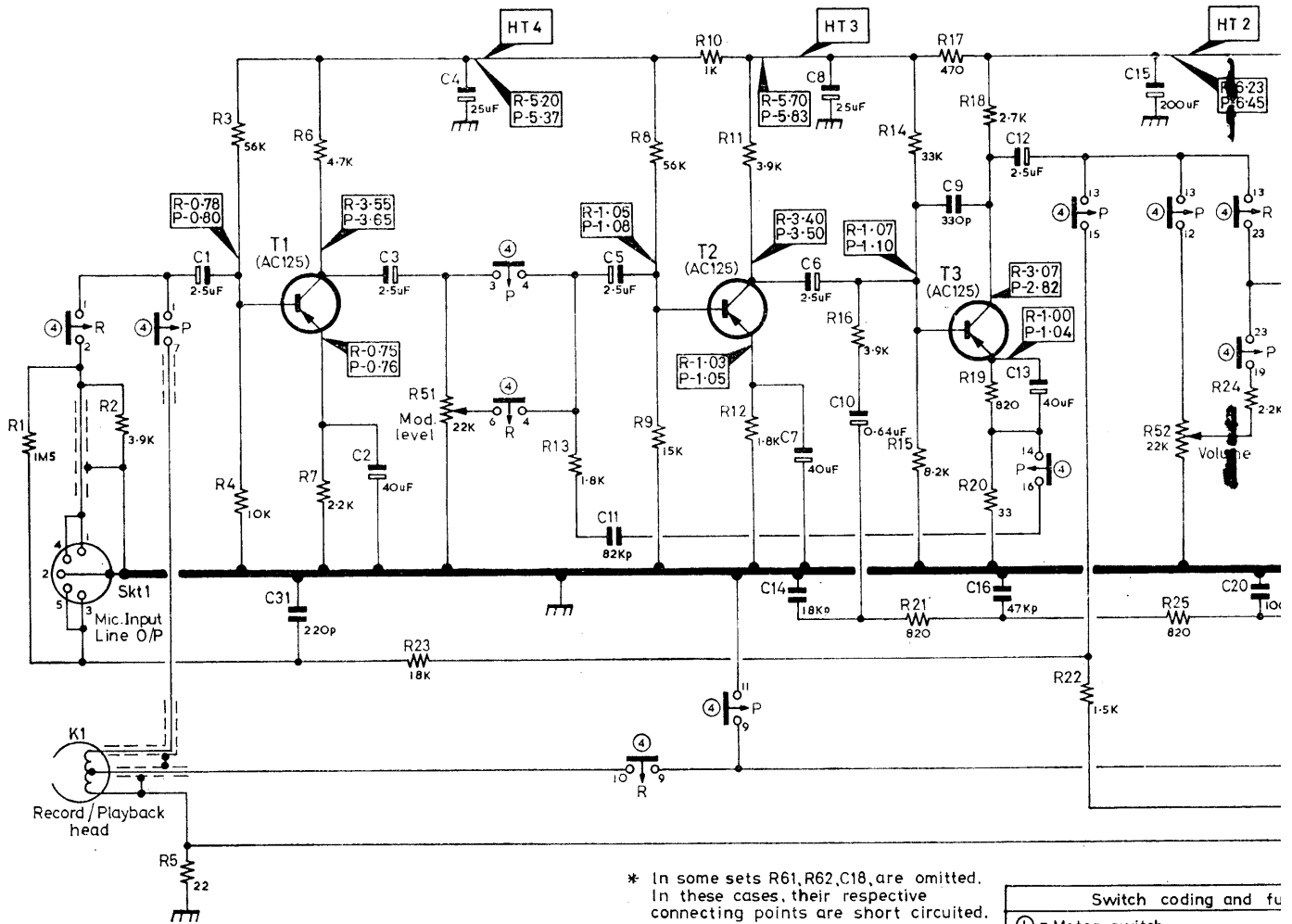

Fig. II—Exploded View

C	1.	3.	4.	5.	7.	6.	8.	9.	12.	15.
R	1.	2.	3.	6.	8.	10.	11.	14.	17.	18.
Misc	Skt1.	T1.	T2.	T3.						
	K1.									



* In some sets R61, R62, C18, are omitted. In these cases, their respective connecting points are short circuited.

Switch coding and fu	
①	= Motor switch
②	= Remote control bypass
③	= Internal speaker
④	= Record / Playback
Switches close only for funct	

Note: For alternative values of C21, C27-29 and R30, R33, R35, R37-39, R41-43, see Spare Parts List.

Voltages taken with respect to c 100KΩ/Vmeter. +ve lead to chas input. Supply voltage = 7.5V

Fig. 12—Circuit D

17.	19.	22.	26.	22.	25.	28.	C
20.	18.	21.		23.	30.	27.	
24.	26.	36.	42.	42.	41.	61.	R
31.	27.	35.	33.	35.	38.	45.	
	T4.	T8.	ME1.	T5.	T6.	44.	Misc
		Skt 2.	L1. M.	X3.	T7.	49.	
			L2.		L3.	40.	
						47.	
						48.	
						50.	

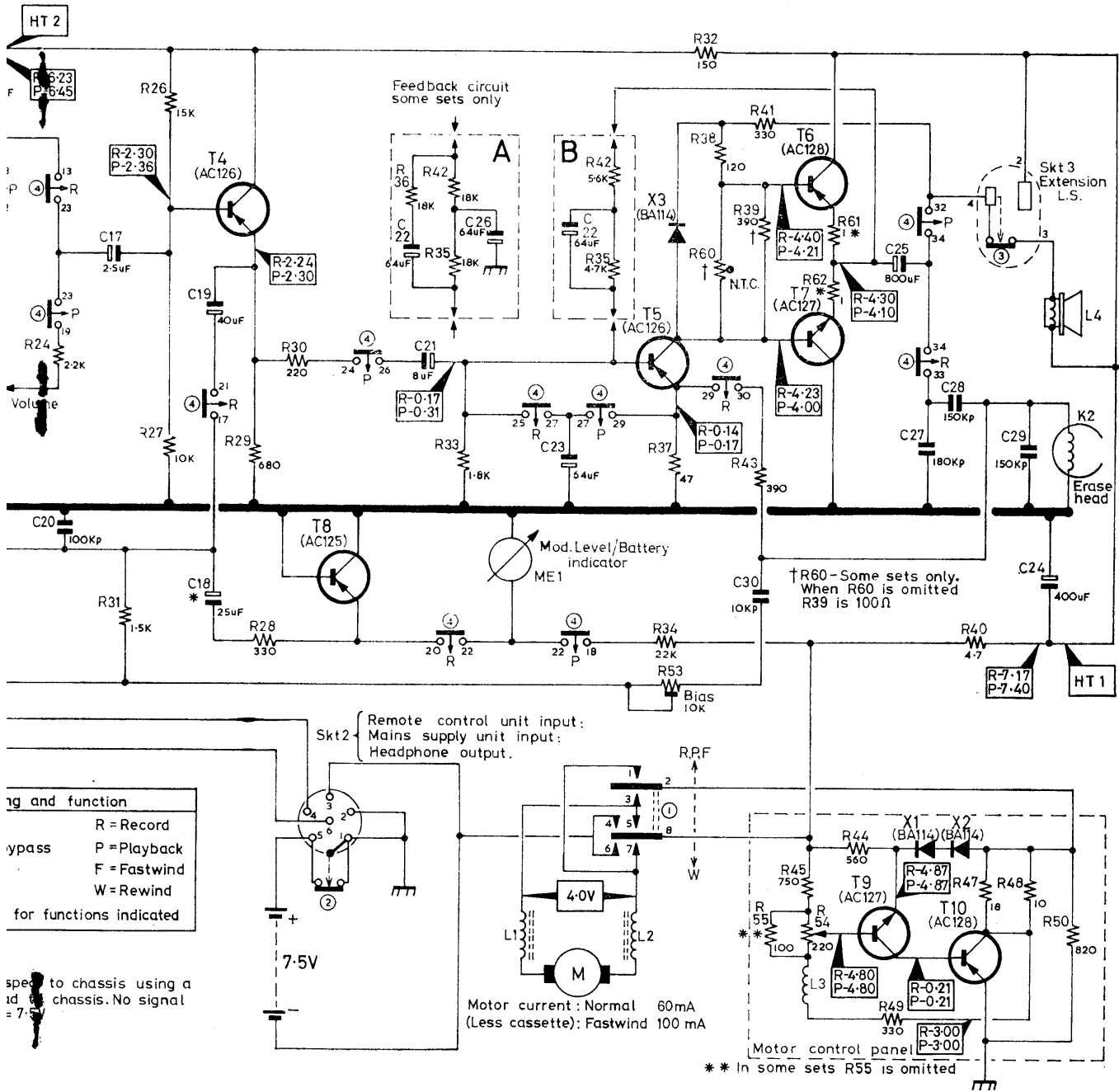

Circuit Diagram

SD3597

I — ELECTRICAL DESCRIPTION OF MOTOR SPEED CONTROL CIRCUIT

The control circuit is fundamentally a D.C. motor in series with a rheostat (T10) across a D.C. supply.

In series with the base of T10 is T9. The emitter potential of T9 is stabilized by diodes X1 and X2 and the base potential of T9 is pre-adjusted by R54 for normal load/voltage conditions. A change in supply voltage, or mechanical load on the motor will initially alter the current drawn by the motor via R47/R48 and T10. The current change will appear as a voltage change on the base of T9 altering its conductivity. The change in conductivity is transferred to T10, due to the direct coupling between them, and will thus control the potential applied to the motor.

The regulating action ceases when the motor speed returns to normal.

J — ELECTRICAL CHECKS AND ADJUSTMENTS

1. Record/playback head (K1) Azimuth adjustment

Remove head cover 89 by sliding it in the direction shown (see Figs. 1 and 2) and place a test tape (5kHz tone) onto the machine. Connect a valve voltmeter to pins 2 and 3 of Skt1. Using a good set of batteries, switch to 'Playback' and adjust screw A (see Fig. 7) for maximum output, then seal it with locking paint.

2. Adjustment of R53 (recording bias)

The bias current should be adjusted so that the overall sensitivity described in para. 3 (c) below is obtained. This current may be measured as a voltage developed across R5 and should lie within the limits of 10-25mV. Switch to the 'Record' position, turn the modulation level control to minimum and connect an A.C. voltmeter between pins 6 and 2 of Skt2. Adjust the bias current with the pre-set potentiometer R53. An increase of current will reduce the treble response and a reduction of current will increase the treble response. Too low a bias current will result in distortion at high modulation levels. Re-lock the potentiometer with locking paint.

3. Sensitivity checks

(a) Playback

Connect an A.F. generator between pin 6 of Skt2 and chassis via a 22K Ω resistor. Turn the volume control to maximum and set the generator output to 40mV at a frequency of 1kHz. Using an A.C. millivoltmeter the following voltages should be measured, at the points indicated and within the limits ± 2 dB.

	T1	T2	T3	T4	T5
Collector ..	0.028mV	2mV	75mV	—	800mV
Emitter ..	—	—	—	30mV	—
Pin 3 Skt1 (Line output)—					50mV
Loudspeaker output (8 Ω resistor replacing loudspeaker) —					630mV

(b) Record

Connect an A.F. generator to pins 1 and 2 of Skt1 via a 1.5M Ω resistor (direct recording lead EL3768/03 is ideal for this purpose). Short circuit the erase head and turn the modulation level control to maximum. With the generator output set to 120mV at a frequency of 1kHz, the following voltages, measured with respect to chassis, should be observed at the points indicated, within the limits ± 2 dB.

	T1	T2	T3	T4
Collector	3.4mV	14mV	320mV	—
Emitter	—	—	—	300mV
Base	0.6mV	—	—	—
Pin 6 Skt2—				4mV.

(c) Overall

Connect an A.F. generator to pins 1 and 2 of Skt1 via a 1.5M Ω resistor (direct recording lead EL3768/03 is ideal for this purpose). Turn the modulation level control to maximum and set the generator output to 15mV. Then, keeping the generator output constant, record signals of the following frequencies:—

80Hz, 1kHz, 5kHz, 10kHz.

Connect the millivoltmeter to pins 2 and 3 of Skt1 and set the volume control to maximum. Playback the recorded frequencies, observing the voltmeter reading for each one. The difference between the highest and lowest readings should not be greater than 6dB. If the difference is greater than this, the recording bias should be checked, as per para. 2 above.

K — MICROPHONE AND REMOTE CONTROL UNIT

1. EL3302A/15

Type EL3797/50—An omni-directional, moving coil 'stick' microphone onto which is clipped the remote control switch. When the remote control switch plug is inserted into socket Skt2, switch S2 is opened, and its function is performed by the remote control switch.

Dismantling (see Fig. 14)

To detach the remote control switch unit, press it downwards and slide it from the end of the microphone body. To dismantle the microphone, prise off ornamental ring 211 with the aid of a small screwdriver, remove grille 212, rubber gasket 209 and foam padding. The capsule can now be lifted out, secured only by its connecting leads which may now be unsoldered.

Re-assemble in the reverse order.

2. ST473

Type EL1974/13—An omni-directional, moving coil 'stick' microphone. The remote control switch is an integral part of the microphone assembly.

Dismantling (see Fig. 15)

Remove screw 416 and lift off lid 405; this gives access to the connecting leads and remote control switch assembly. To remove capsule, withdraw screw 415 and slide clip 402, and cover 401 from the end of the microphone body, then disconnect the capsule connecting leads. Insert a pin through the aperture for the capsule connecting leads and carefully push the capsule out of the end of the case.

Re-assemble in the reverse order.

L — CASSETTE ASSEMBLY

Spare parts for the cassette are not obtainable and dismantling is not advised because of the spring loaded construction. However, should it be inadvertently dismantled, Fig. 13 will assist in re-assembling. The complete cassette with tape is available, see Spare Parts List.

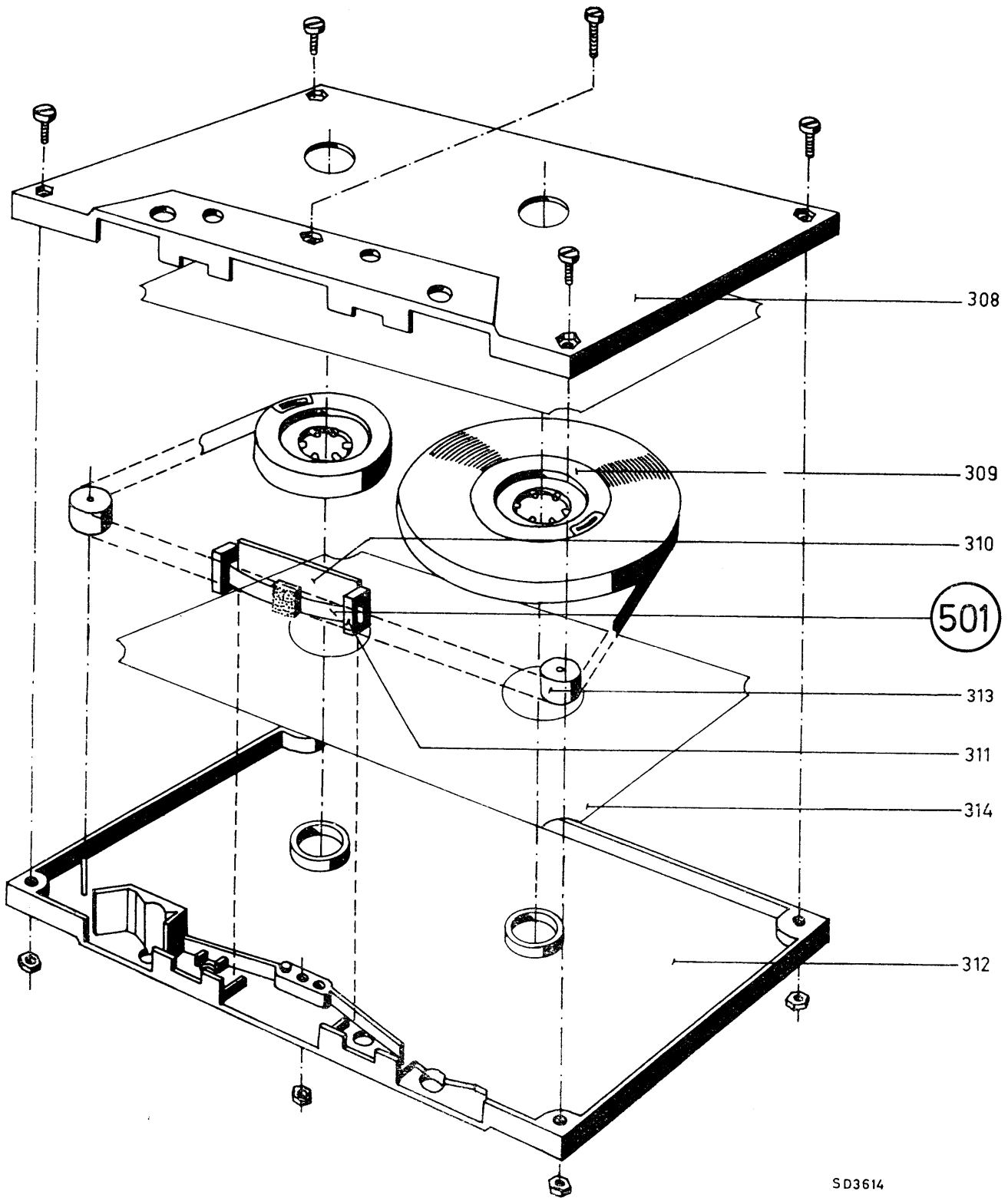

SD3614

Fig. 13—Cassette Assembly EL1903

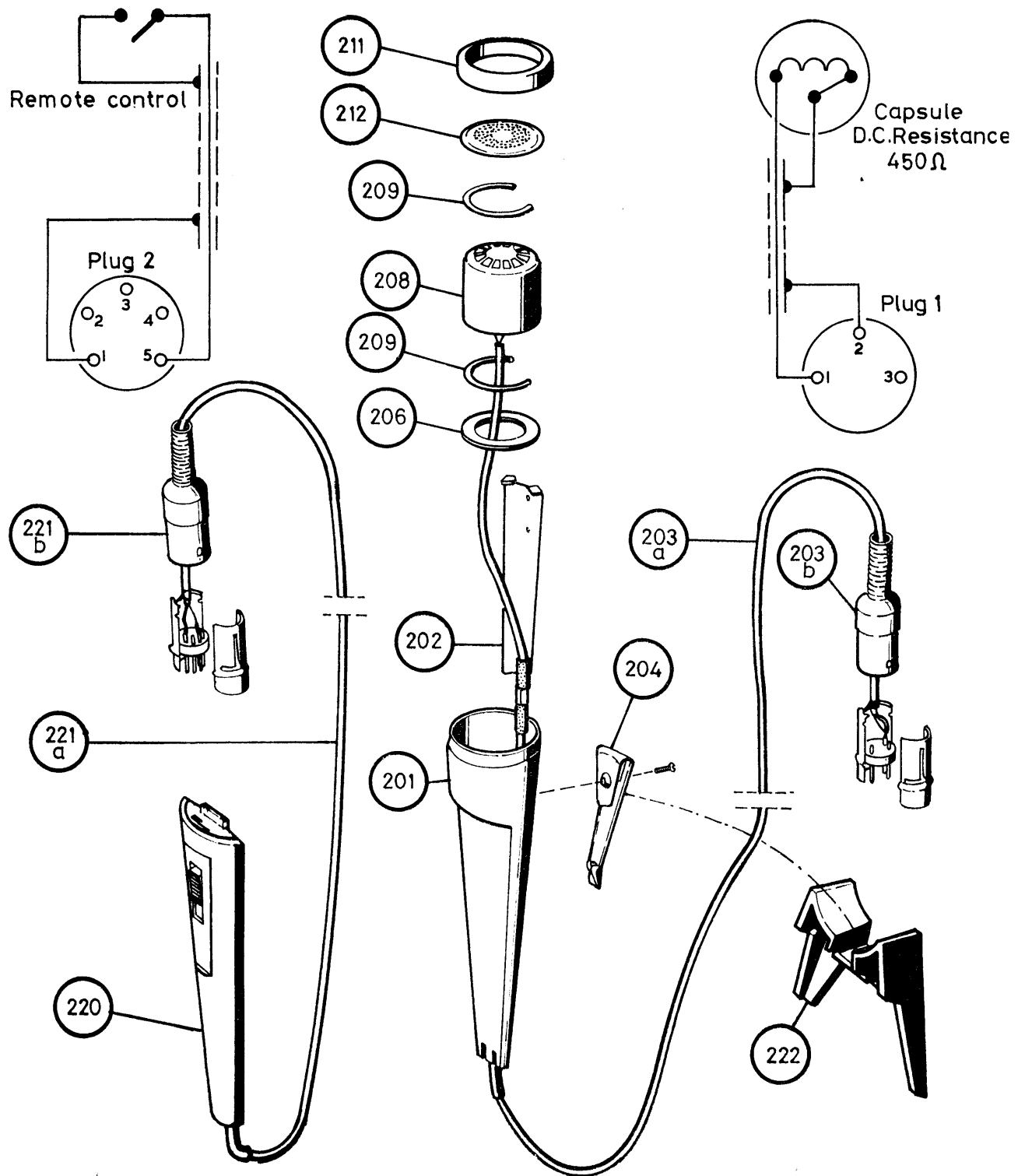

SD3613

Fig. 14—Microphone and Remote Control Unit—EL3797/50

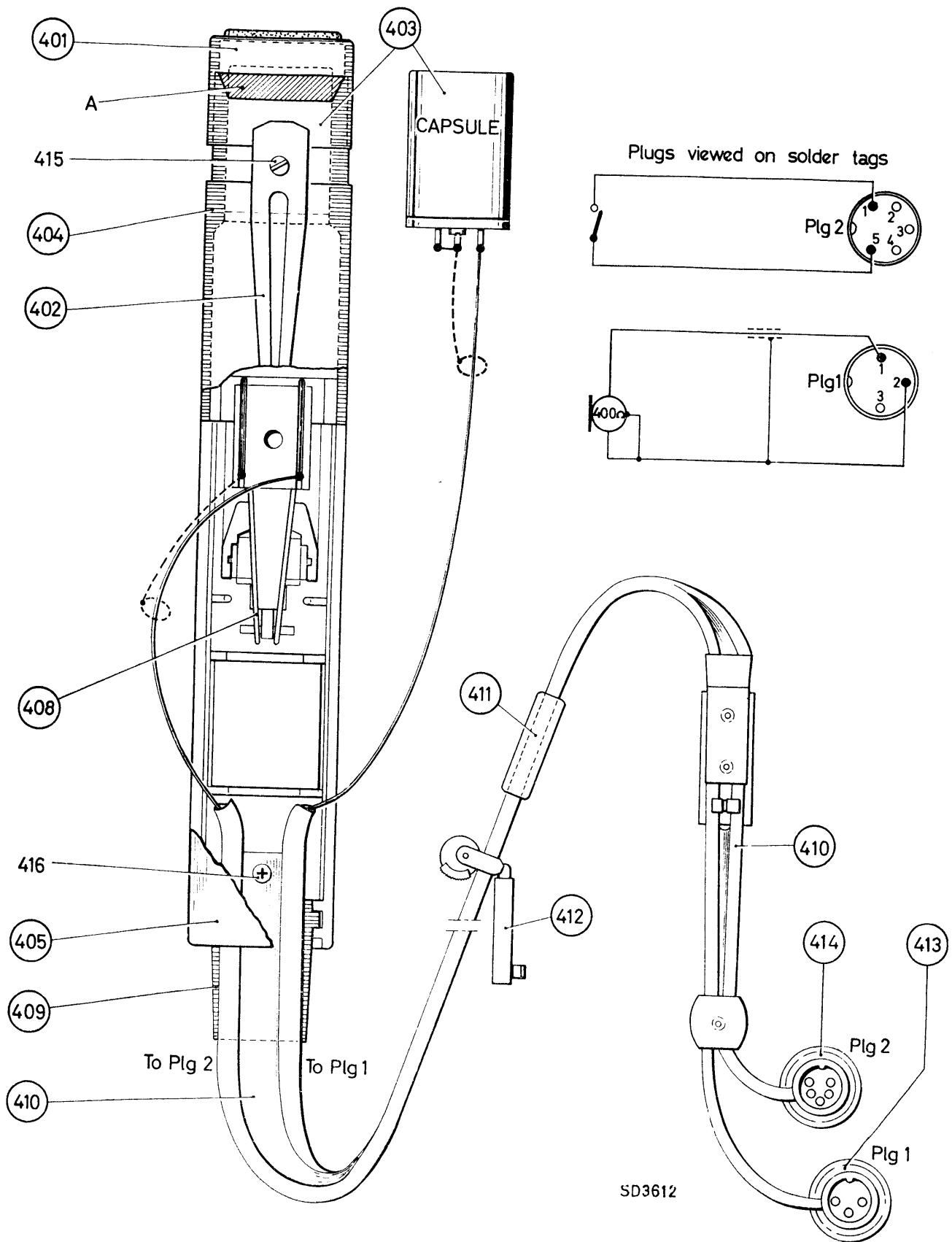

Fig. 15—Microphone and Remote Control Unit—EL1974/13

M — SPARE PARTS LIST

SUPPLY OF SPARE PARTS: To ensure correct interpretation of requirements please include the following information on orders for spare parts.

1. The full type number recorded on the type number plate, including any suffix. **Do not use the commercial abbreviation which may be misleading.**
2. Whenever possible, quote the serial number of the recorder. In some recorders the components have been changed during production.
3. **Always give a brief description** and colour where applicable.
4. Quote part number.

If it is necessary to return components, always include full identification on the accompanying advice note.

CABINET ASSEMBLY

		EL3302A/15	ST473
75	Ornamental grille	458.30102	458.30124
77	Cabinet assembly	443.30101	443.30116
78	Reflector plate	175.01361	175.01361
79	Cassette cover	443.60195	443.60053
80	Modulation/battery meter	175.00935	175.00935
81	Operating knob	410.10012	410.30039
82	Record button	410.10011	410.20237
83	Battery cover	443.60194	443.60076
84	Chassis securing screw	B.054.ED/2.6 × 23	B.054.ED/2.6 × 23
85	Bottom plate	443.60193	443.50109
86	Cabinet securing screw	999/2.6 × 15	999/2.6 × 15
83	Knobs (2)	412.20003	412.20009
	Compression springs for above	492.50416	492.50516
89	Cover for heads	443.60192	443.60212
	Speaker fabric	175.01359	175.01359
	Philips emblem	735.12368	—

MECHANICAL ASSEMBLY

1	Screw 2 × 5 mm.	999/2 × 5	52a	Brake block (2)	466.40077
2	Washer 3mm.	988/3	53	Pressure roller assembly	175.00957
3	Screw 2 × 8 mm.	999/2 × 8	54	Turntable assembly (2)	175.00964
4	Lockwasher 3 mm.	987/3	55	Torsion spring on pressure arm	175.00958
5	Screw 2 × 12 mm.	999/2 × 12	56	Nylon circlip	175.00986
6	Circlip	985/1.9	57	Leaf spring for cassette	492.60926
7	Lockwasher 3mm.	986/3	60	Spring for item 63	175.00974
8	Circlip 2.3 mm.	985/2.3	62	Switch S1	175.01514
9	Screw 2.6 × 6 mm.	B054.ED/2.6 × 6	63	Clutch assembly	175.00951
25	Erase head, K2	249.40039	64	Nylon circlip	175.01055
26	Record/playback head, K1	249.10032	65	Drive belt—large	358.30076
28	Spring under record/playback head	175.00955	66	Flywheel	175.00971
29	Leaf spring under record button	175.00956	67	Flywheel lower bearing bracket	175.00972
30	Locating spring	175.00961	68	Motor assembly	194.00239
31	Locating roller assembly	175.00962	69	Rubber buffer	163.00919
35	Ball bearing	89.205.01	70	Spindle for turntable	175.00977
36	Switch lever	163.00922	71	Switch plate assembly	403.30089
37	Return spring	175.00965	73	Record interlock bracket	175.01203
38	Mounting spring for meter	175.00947	74	Spring for item 73	175.01202
39	Nylon circlip	TD.300.49	90	Socket plate assembly	267.20073
40	Guide roller	528.90081	91	Leaf spring under operating knob	492.60927
41	Tape transport arm	430.50412	93	Contact spring A of S2-S3	268.20034
43	Spring for tape transport arm	492.60912	94	Contact spring B of S2-S3	268.20033
44	Winding roller assembly	175.00966	95	Contact spring C of S1-S3	268.20032
45	Drive roller	175.00967	300	Carriage plate assembly	403.50439
46	PVC washer	175.00968		Set of battery and loudspeaker contact plates	310.20175
47	Drive belt—small	358.30077			
48	Wire pull-on spring for posn. 52	175.00944			
49	Forked spring for posn. 52 (some sets only)	175.01251			
50	Tension pull-off spring for posn. 52	175.00945			
51	Cap for turntable (2)	163.00918			
52	Brake bracket assembly	175.00943			

MISCELLANEOUS

Motor control print	194.00257
Battery interconnection spring	492.60925
Rubber sleeve for motor	163.00921
Battery indication sheet	3104.103.40171

ELECTRICAL

SEMI-CONDUCTORS

T1	Transistor
T2	"
T3	"
T4	"
T5	"
T6	"
T7	"
T8	"
T9	"
T10	"
X1	Diode
X2	"
X3	"

TRANSFORMERS AND COILS

AC125	K1	Record/playback head (posn. 26)	249.10032
AC125	K2	Erase head (posn. 25)	249.40039
AC125	L1	Motor choke	107.00322
AC126	L2	"	107.00322
AC126	L3	Choke	157.50013
AC128	L4	Loudspeaker	240.30033
AC127	M	Motor (posn. 68)	194.00239
AC125	ME1	Meter (posn. 80)	175.00935

SWITCHES

BA114	S1	Battery switch (posn. 62)	175.01514
BA114	S4	Record/playback switch	277.30307

CAPACITORS

Type	Value uF
C1	Electrolytic ... 2.5
C2	" ... 40
C3	" ... 2.5
C4	" ... 25
C5	" ... 2.5
C6	" ... 2.5
C7	" ... 40
C8	" ... 25
C9	Pin-up ... 330pF
C10	Electrolytic ... 0.64
C11	Foil ... 82KpF
C12	Electrolytic ... 2.5
C13	" ... 40
C14	" ... 18KpF
C15	" ... 200
C16	Foil ... 47KpF
C17	Electrolytic ... 2.5
C18	" (some sets only) 25

Type	Value uF	
909/W2.5	C19	" ... 40
C420.AN/A40	C20	Foil ... 100KpF
909/W2.5	C21	Electrolytic ... 2.5
909/A25	or C21	" ... 8
909/W2.5	C22	" ... 64
909/W2.5	C23	" ... 64
C420.AN/A40	C24	" ... 400
909/A25	C25	" ... 800
904/P330E	C26	" (some sets only) 64
909/Z064	C27	Foil ... 100KpF
069.01104	or C27	Foil ... 180KpF
909/W2.5	C28	Foil ... 100KpF
C420.AN/A40	or C28	Foil ... 150KpF
069.01096	C29	Foil ... 100KpF
909/U200	or C29	Foil ... 150KpF
069.01101	C30	Pin-up ... 10KpF
909/W2.5	C31	Pin-up ... 220pF
909/A25		
		C420.AN/A40
		069.01105
		909/W2.5
		909/X8
		069.00578
		069.00578
		909/U400
		124.20196
		069.00578
		069.01105
		121.50174
		069.01105
		121.50173
		069.01105
		121.50173
		069.01093
		904/P220E

RESISTORS

Type	Value Ω
R1	... 1.5M
R2	... 3.9K
R3	... 56K
R4	... 10K
R5	... 22
R6	... 4.7K
R7	... 2.2K
R8	... 56K
R9	... 15K
R10	... 1K
R11	... 3.9K
R12	... 1.8K
R13	... 1.8K
R14	... 33K
R15	... 8.2K
R16	... 3.9K
R17	... 470
R18	... 2.7K
R19	... 820
R20	... 33
R21	... 820
R22	... 1.5K
R23	... 18K
R24	... 2.2K
R25	... 820
R26	... 15K
R27	... 10K
R28	... 330
R29	... 680
R30	... 470
or R30...	... 220
R31	... 1.5K
R32	... 150

Type	Value Ω	
902/K1M5	R33	... 4.7K
902/A3K9	or R33...	... 1.8K
902/A56K	R34	... 22K
902/A10K	R35	... 18K
902/A22E	or R35...	... 4.7K
902/A4K7	R36	(Some sets only) 18K
902/A2K2	R37	... 18
902/A56K	or R37...	... 47
902/A15K	R38	... 150
902/A1K	or R38...	... 120
902/A3K9	R39	... 150
902/A1K8	or R39...	... 100
902/A1K8	R40	... 4.7
902/A33K	R41	... 270
902/A8K2	or R41...	... 330
902/A3K9	R42	... 18K
902/A470E	or R42...	... 5.6K
902/A2K7	R43	... 270
902/A820E	or R43...	... 390
902/A33E	R44	... 560
902/A820E	R45	... 750
902/A1K5	R47	... 18
902/A18K	R48	... 10
902/A2K2	R50	... 820
902/A820E	R51	Mod. level ... 22K
902/A15K	R52	Volume ... 22K
902/A10K	R53	Pre-set ... 10K
902/A330E	R54	Pre-set ... 220
902/A680E	R55	(Some sets only) 100
902/A470E	R60	N.T.C. (some sets only) ...
902/A220E	R61	... 1
902/A1K5	R62	... 1
902/A120E		
		902/A4K7
		902/A1K8
		902/A22K
		902/A18K
		902/A4K7
		902/A18K
		902/A18E
		902/A47E
		902/A150E
		902/A120E
		902/A150E
		902/A100E
		071.00587
		902/A270E
		902/A330E
		902/A18K
		902/A5K6
		902/A270E
		902/A390E
		902/A560E
		110.60104
		902/A18E
		902/A10E
		902/A820E
		071.00677
		071.00677
		071.00837
		100.10026
		902/A100E
		116.30016
		B8.031.04NB/1E
		B8.031.04NB/1E

ACCESSORIES
(Supplied with the Recorder)

MICROPHONE

EL3302A/15				ST473			
	Microphone assembly complete	EL3797/50	Microphone assembly complete	...	EL1974/13
201	Housing	447.10099	401	Chrome cap	447.10115
202	Mounting plate	169.00519	402	Pocket clip	404.50243
203a	Lead	322.10013	403	Capsule	EL6077/15
203b	Plug	264.40018	404	Case	447.10116
204	Pocket clip	169.00534	405	Lid	128.00815
206	Foam pad	169.00524	408	Contact spring	492.60719
208	Capsule	EL6091/10	409	Grommet	325.50037
209	Rubber gasket	530.20042	410	Lead with plugs	321.20081
211	Ornamental ring	432.20007	411	Strap adjustment clip	404.50126
212	Grille	447.10101	412	Clamping roller assembly	128.00817
220	Remote control unit complete	EL3796/00	413	3-pole plug	264.40054
221a	Lead	322.10013	414	5-pole plug	264.40055
221b	Plug	978/5 x 270			
222	Stand for microphone	462.10072			

LEAD ASSEMBLY			
	Lead assembly complete	...	EL3768/03
	Lead only	...	R365.KA/56FP9
RA1	Resistor	...	B8.305.80A/1M5
	Plug 5-pin DIN	...	978/5 x 180
	Black cover for plug	...	268.47001

CASSETTE ASSEMBLY			
	*Cassette with tape	...	EL1903
501	Pressure pad	...	175.01441
CARRYING CASE			
	Carrying case (EL3302A/15 only)	...	600.70014

* Supplies of magnetic tape (or tape cassettes as applicable) should be obtained from the General Sales Division of Philips Electrical Ltd.