



For more Hi-Fi manuals and set-up information
please visit www.hifiengine.com



SERVICE MANUAL 1040



marantz

model 1040

Stereo Console Amplifier

TABLE OF CONTENTS

SECTION	PAGE
Introduction	1
Pre-amplifier	1
Main Amplifier	1
Power Supply Unit	1
Trouble Analysis	1
Power Amplifier Adjustment	2
Performance Verification	2
Test Equipment Required for Servicing	4
Parts List	15
Technical Specifications	20
Service Information for European Model	21

LIST OF ILLUSTRATIONS

FIGURE	PAGE
1. AC Power Control Box Simplified Schematic	2
2. Amplifier Output Load Box Simplified Schematic	5
3. Front Panel Adjustments and Component Locations	6
4. Main Chassis Component Locations (Top View)	6
5. Rear Panel Adjustment and Component Locations	7
6. Main Chassis Component Locations (Bottom View)	7
7. Phono Amplifier Assembly P400 Component Locations	8
8. Tone Amplifier Assembly PE01 Component Locations	8
9. Main Amplifier Assembly P700 Component Locations	8
10. Power Supply Assembly P800 Component Locations	9
11. Loudness and Hi Filter Switch PS01 Component Locations	9
12. Speaker Switch Assembly PT01 Component Locations	9
13. Tone Control Assembly PF01 Component Locations	9
14. Exploded Mechanical Diagram	11~12
15. Schematic Diagram	13~14
16. Rear Panel Adjustments and Facilities Locations for European Model	22
17. Main Chassis Component Locations (Top View) for European Model	22
18. Schematic Diagram for European Model	23~24
19. Voltage Conversion Chart	25

TABLE	PAGE
1. Test Equipment Required for Servicing	4

1. INTRODUCTION

This service manual was prepared for use by Authorized Warranty Stations and contains service information for Marantz Model 1040 Stereo Console Amplifier.

Servicing information and voltage data included in this manual are intended for use by the knowledgeable and experienced technician only. All instruction should be read carefully. No attempt should be made to proceed without a good understanding of the operation in the circuits.

The part lists furnish information by which replacement part may be ordered from the Marantz Company. A simple description is included for parts which can be usually be obtained through local suppliers.

2. PRE-AMPLIFIER

Signals from the input jacks (TUNER, TAPE, AUX) are applied to the SELECTOR switch.

Signals from the PHONO jacks is applied to the other section of the SELECTOR switch, then, led to the phono-amplifier and equalized to match the RIAA curve for flat frequency response. The gain of the phono-amplifier consisting of direct coupled circuit (H401 and H403) is 38dB.

The outputs of the phono-amplifier are led to the SELECTOR switch. The SELECTOR switch selects one of signals from PHONO, TUNER, or AUX jacks and send it to the TAPE MONITOR switch and TAPE OUT jacks. The selected signals are then applied to the BALANCE and VOLUME controls, then to the pre-amplifier consisting of PE01, PE03 and PE05 through MODE switch.

The frequency response is varied by the BASS and TREBLE controls, and the resultant output are led to main amplifier through High-cut filter network. This network is switched in and out from the circuit by the pushswitch.

3. MAIN AMPLIFIER

Differential amplifier consists of the transistors H701 and H703 to provide satisfactory D.C. stability.

The transistor H705 drives the inverter transistors H711 and H713 which, in turn, drive the power stage consisting of H001 and H002. Transistors H707 and H709 are current limiter operating as a power transistor protection circuit.

Excessive current flow in the power output stage is detected by the resistors R751 and R753 and the resultant variation is applied to the transistors H707 and H709 and make them turned on. This decreases the base biasing current for H711 and H713. In this way the current flow in the power output stage (H001 and H002) is restricted within a safe predetermined value.

4. POWER SUPPLY UNIT

This power supply unit consisting of a transistor H801, which operates as a ripple filter, provides +35V DC to the Phono-amplifier and the Tone Amplifier.

5. TROUBLE ANALYSIS

1. Excessive line consumption
 - a. Check for shorted H802 through H806.
 - b. Check for shorted transistor H001 through H004.
Check L001 for short.
2. No line consumption or zero bias
 - a. Check line cord, fuse, shorted H005, H006.
 - b. Check for open rectifiers H802 through H806.
3. High hum and noise level
 - a. Check filter capacitors C002, C003, C805, C806.
4. Parasitic oscillation
 - a. Check for defective C707, 708, C715, C716.

6. POWER AMPLIFIER ADJUSTMENT

1. Connect a high-sensitivity voltmeter between J709 + and J711 - ; then, adjust the trimming resistor R763 for 20mV DC. For other channel connect a high-sensitivity voltmeter between J720 + and J721 - ; then, adjust trimming resistor R764 for 20mV DC.
2. Connect a high-sensitivity voltmeter between J707 and chassis; then, adjust a trimming resistor R761 for 0mV DC. For other channel connect a high-sensitivity voltmeter between J718 and chassis; then, adjust R762 for 0mV DC.

7. PERFORMANCE VERIFICATION

Test Procedure

A. Test Equipment

Refer to Table 1 for required test equipment.

B. Preliminary Procedures

1. Make the test setup shown in Figure 1 with the instrument controls set in the following positions:

Line Switch	off
Variable-line switch	variable
Watt Meter Switch	on
Variac	0 (fully CCW)
Load	8 ohms (0.5 mfd – off)
Audio Generator	Frequency 1kHz

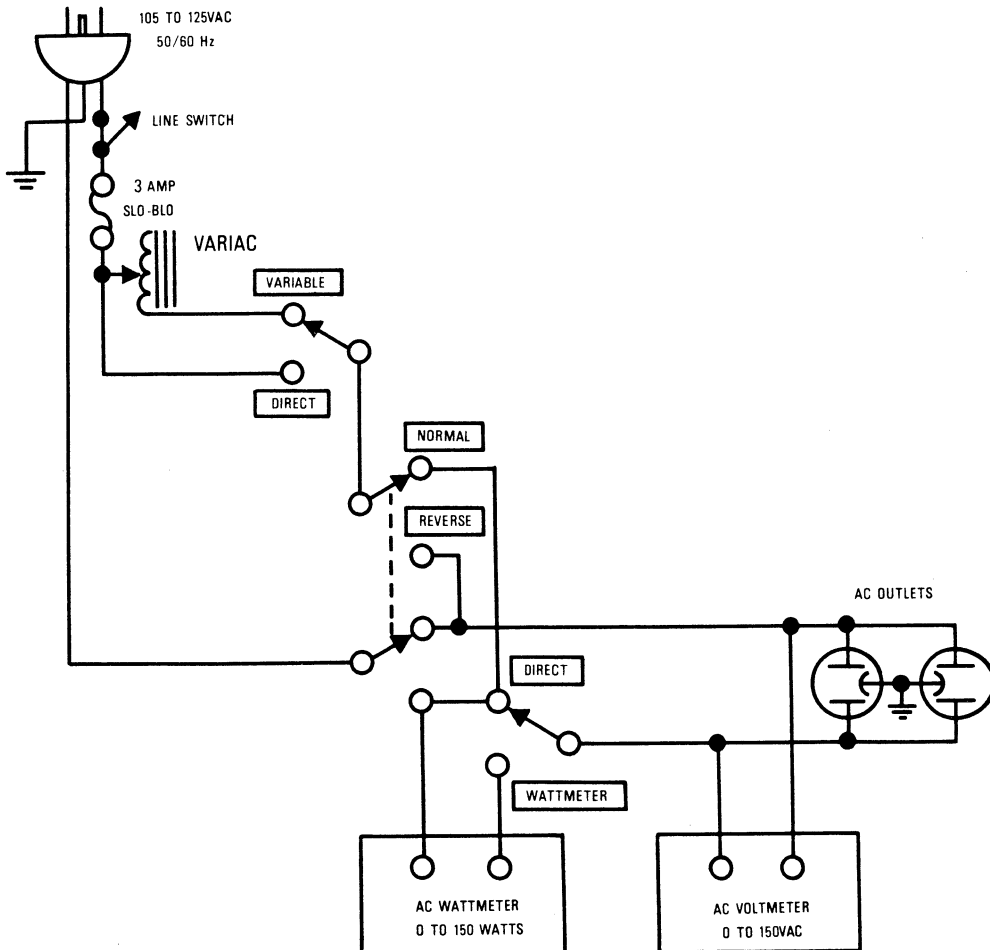

Figure 1. AC Power Control Box Simplified Schematic

Output	5V range
Gain	Minimum
AC Volt Meter	30V range

2. Make sure that connections between the resistive load and the system terminals of the Model 1040 have negligible resistance compared with the resistance of the load itself. Appreciable resistance in wiring adds to the total load, resulting in inaccurate measurements of output power.
3. Connect amplifier output to load and connect AC cord to line power. Connect a shorting plug to the PHONO INPUT jack of the Model 1040.
4. Remove the top cover.

C. Total Hum and Noise Test

1. With shorting plugs connected to the PHONO INPUT jacks and a 8-ohm resistive load connected across the speaker system output terminals, connect a distortion analyzer across the load.

NOTE: In this test and tests that follow, if distortion analyzer used does not contain a built-in voltmeter, a VTVM may be substituted.

2. Set the distortion analyzer controls for voltage measurements and apply power to the amplifier. Set the VOLUME control fully CCW. Set the SELECTOR switch to PHONO.
3. If the distortion analyzer indicates more than 1.0mV, refer to the trouble analysis section of this manual.
4. Set the VOLUME control fully CW. If the distortion analyzer indicates more than 15mV refer to the trouble analysis section of this manual.

D. Maximum Power Output

1. Connect the audio oscillator to the AUX input. Set audio oscillator frequency to 1kHz. Set SELECTOR switch to AUX.
2. With the distortion analyzer connected across the output load (8 ohms), set the analyzer on the 30V AC scale.
3. Turn the analyzer on and increase the audio oscillator output to 150mV, and verify the analyzer indicates about 12.6V.

E. Harmonic Distortion Test

1. Set the frequency of the audio oscillator and the distortion analyzer to 20kHz.
2. Set the controls of the analyzer for voltage measurement on the 30-volt scale.
3. Adjust the audio oscillator output level until the analyzer meter indicates 12.6 volts.
4. Switch the distortion analyzer to Set Level – Manual mode, and adjust SENSITIVITY for full scale reading on 0–1 scale.
5. Measure the total harmonic distortion with the analyzer and verify it is less than 0.3%.

NOTE: Any parasitic oscillation in the amplifier will be displayed on the oscilloscope when capacitance is switched into the load.

6. Switch the distortion analyzer back to SET LEVEL MANUAL. (Do not adjust sensitivity of analyzer).
7. Change the frequency of the audio oscillator and distortion analyzer to 1kHz. Adjust audio oscillator output as necessary to have a full scale reading on the 0–1 scale on the analyzer.
8. Measure the distortion, verifying it is no greater than 0.3%.
9. Repeat steps 7 and 8, changing frequency to 20Hz. Distortion should be no more than 0.3%.
10. Check for parasitic oscillations; there should be none.

F. Channel Separation

1. Set an audio oscillator to 20kHz. Connect the audio oscillator to channel L AUX input only, with shorting plug (10 kohms) in channel R AUX input. Connect distortion analyzer to SPEAKER output terminals channel L.
2. Adjust oscillator output 1V.
3. Attenuate the VOLUME control until 10W (8.9V) position on distortion analyzer; then, set the distortion analyzer to 0dB.

4. Measure channel R output. Distortion analyzer should indicate -30dB or greater.
5. If indication is less than -30dB , remove input wires which connected SELECTOR to pre-amp. board; then, reach out the best location.

8. TEST EQUIPMENT REQUIRED FOR SERVICING

Table 1 lists the test equipment required for servicing the Model 1040 Stereo Console Amplifier. The wattmeter, AC voltmeter, and variac may be assembled as a test fixture as shown schematically in Figure 1, and the load resistors and AC ammeter may be assembled into a second test fixture as shown in Figure 2.

Item	Manufacturer and Model No. (or equivalent)	Use
Distortion Analyzer	Hewlett Packard, Model 331A or 333A	Measures distortion and voltage of amplifier output.
Audio Oscillator	Weston Model CVO-100P (NOTE: Less than 0.02 percent residual distortion is required.)	Sinewave and squarewave source.
Oscilloscope	Tektronix, Model 503; Data, Model 555	Waveform analysis and troubleshooting.
VTVM	RCA Senior Volt-Ohmyst, Model WV-98C	Voltage and resistance measurements.
AC Wattmeter	Simpson, Model 390	Monitors primary power consumption of amplifier.
AC Ammeter (0 to 10 amps)	Commercial Grade	Monitors amplifier output under short circuit condition.
Line Voltmeter (0 to 150 vac)	Commercial Grade	Monitors potential of primary power to amplifier.
Variable Autotransformer (0 to 140 vac, 10 amps)	Powerstat, Model 116B	Adjusts level of primary power to amplifier.
Shorting Plug	Use phono plug with 600 ohms across center pin and shell.	Shorts amplifier input to eliminate noise pickup.
Power Supply Bleeder Resistor (10 ohms at 1W)	Commercial Grade	Discharges power supply filter capacitors prior to disassembly or resistance measurements.
Output Load Resistor ($8\Omega \pm 0.5\%$, 250W)	Commercial Grade	Provides 8-ohm load for amplifier output termination.
Output Load Resistor ($4\Omega \pm 0.5\%$, 250W)	Commercial Grade	Provides 4-ohm load for amplifier output termination.
Output Load Capacitor (0.5 mfd)	Mylar	Provides capacitive load for instability checks.
AC Power Control Box	Optional Item. Fabricate in accordance with Figure 1.	Monitors and controls primary power for amplifier.
Amplifier Output Load Box	Optional Item. Fabricate in accordance with Figure 2.	Provides various amplifier loads and can monitor shorted output.

Table 1. Test Equipment Required for Servicing

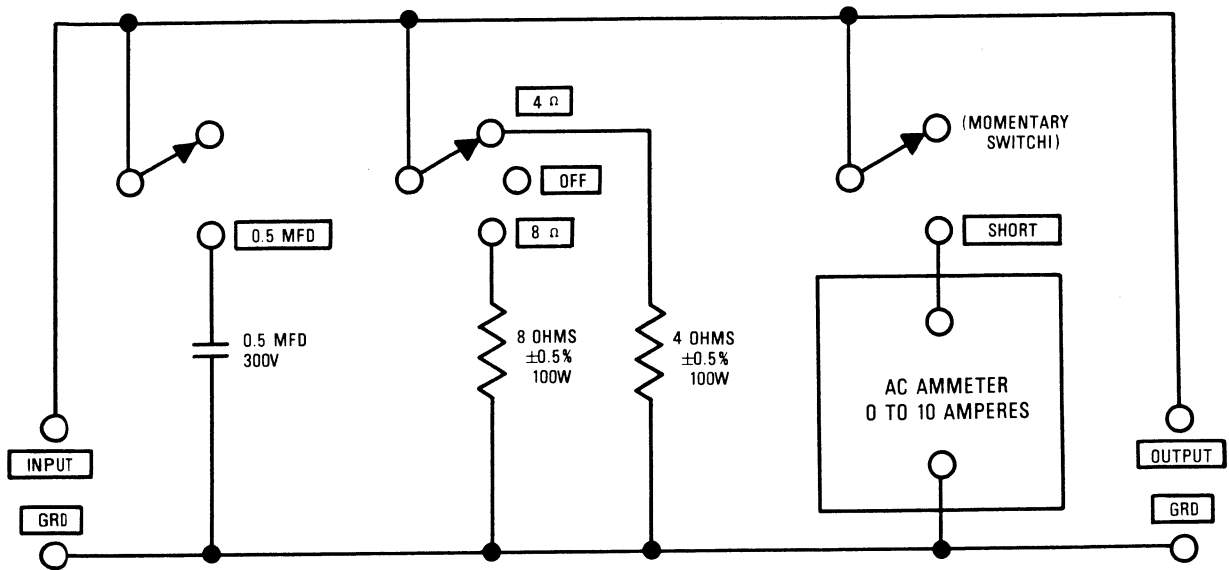

Figure 2. Amplifier Output Load Box Simplified Schematic

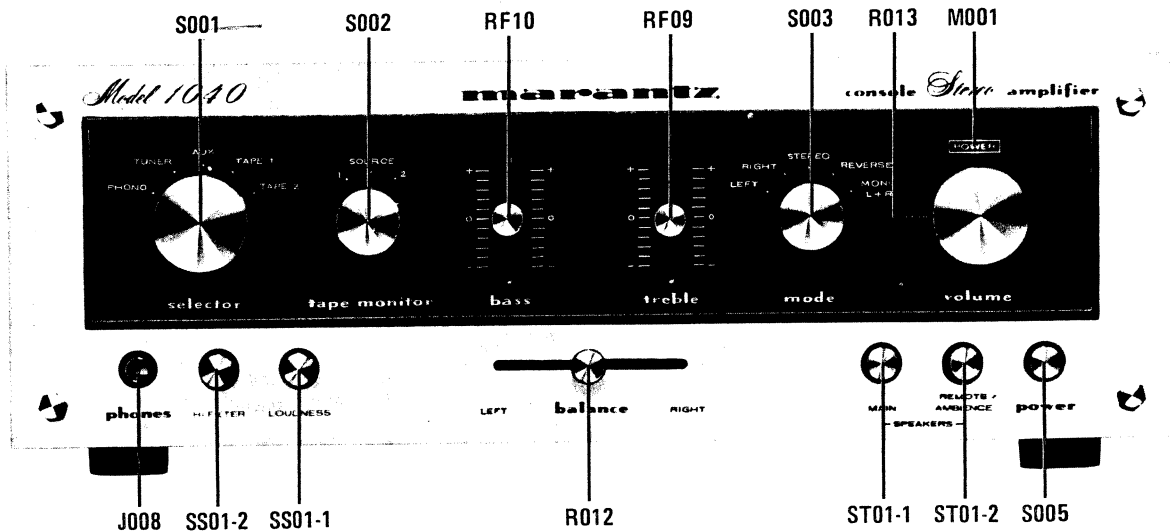

Figure 3. Front Panel Adjustments and Component Locations

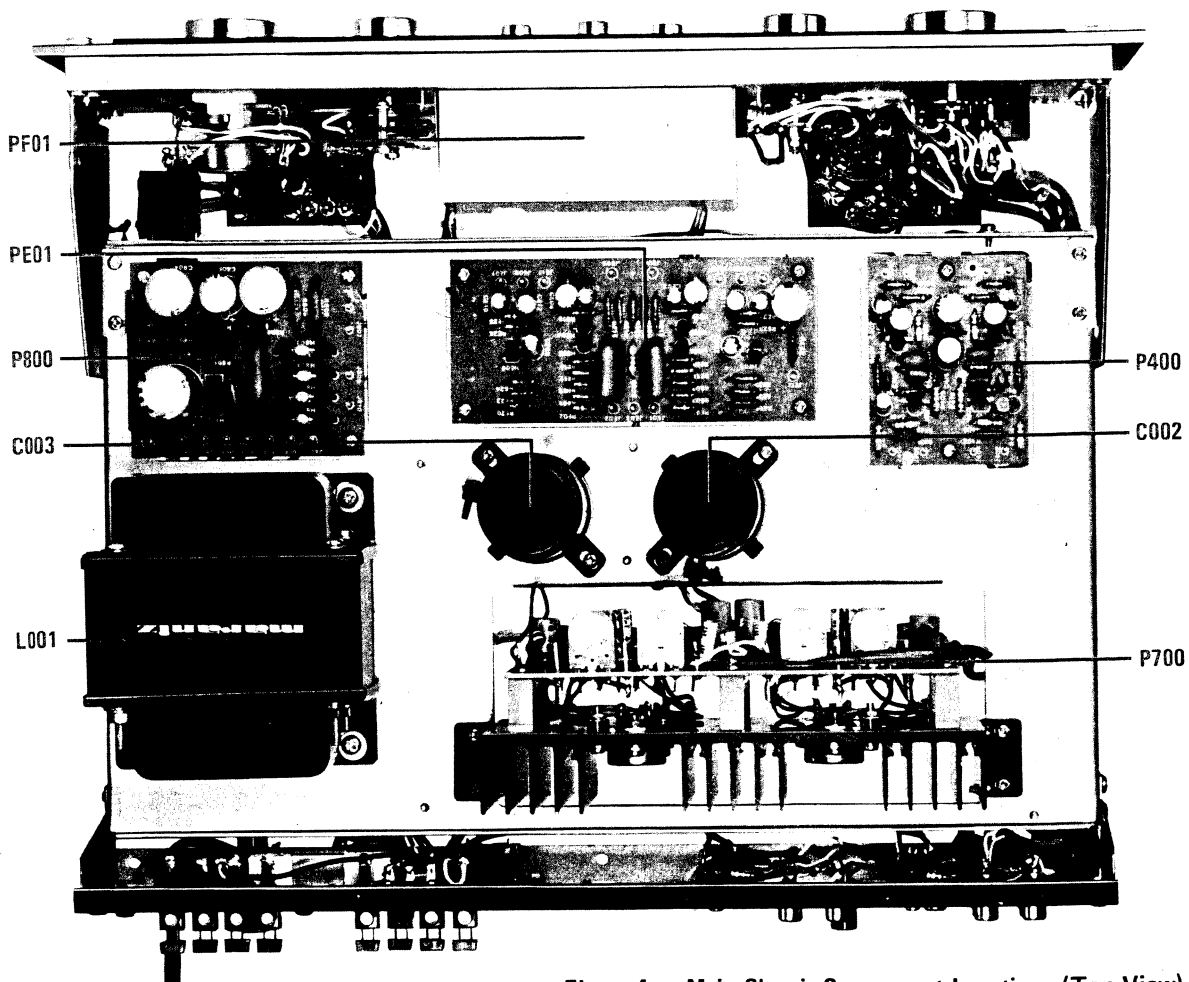

Figure 4. Main Chassis Component Locations (Top View)

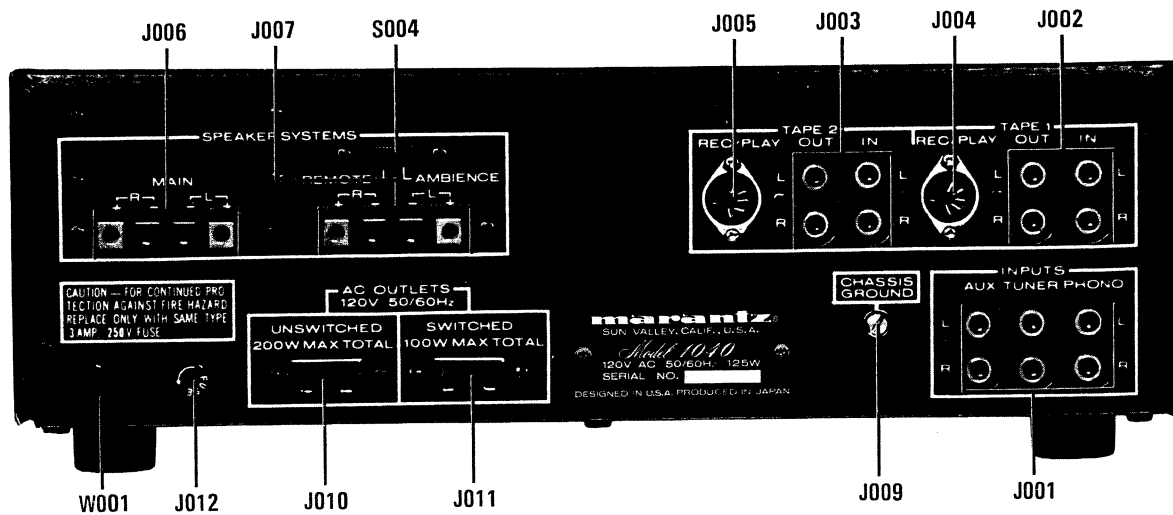

Figure 5. Rear Panel Adjustment and Component Locations

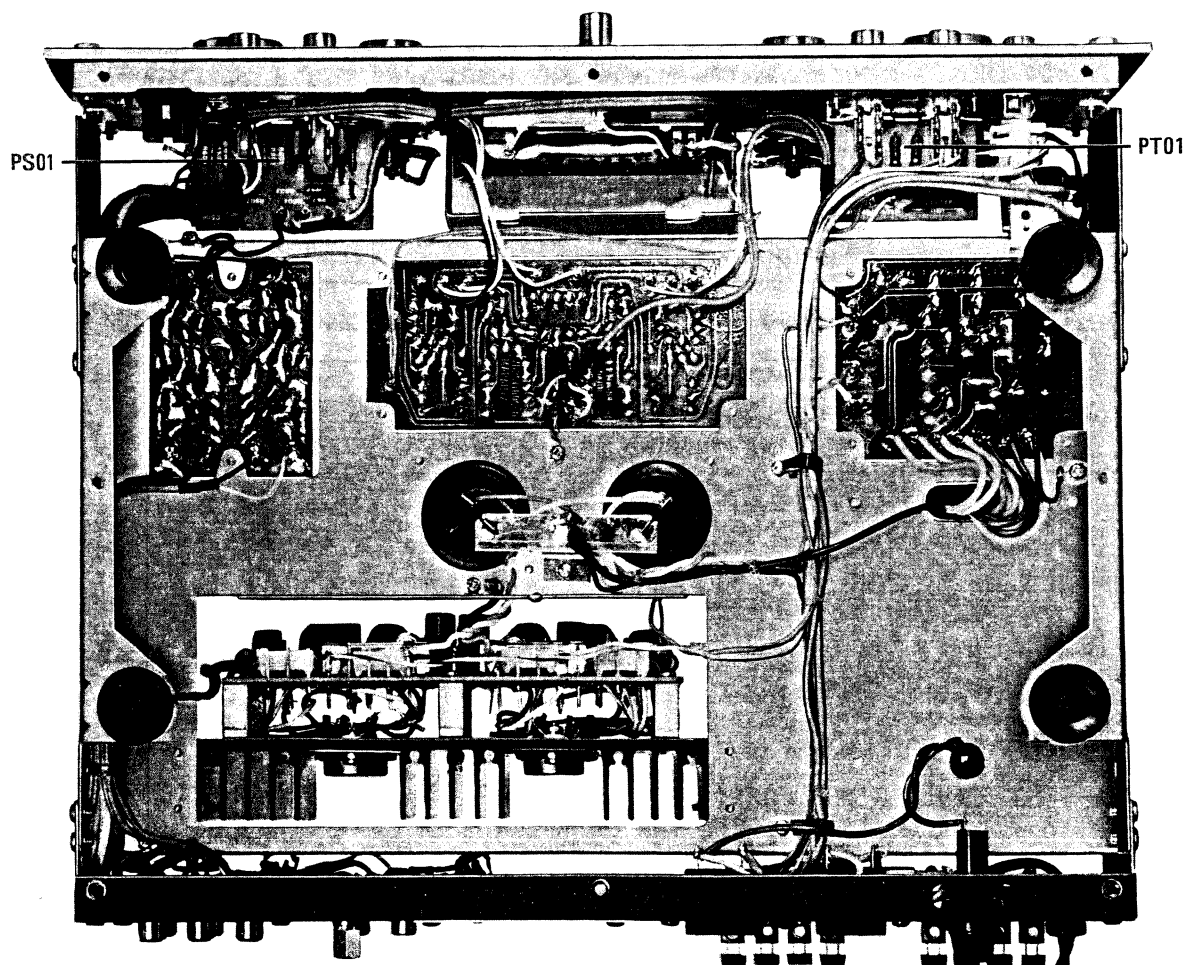

Figure 6. Main Chassis Component Locations (Bottom View)

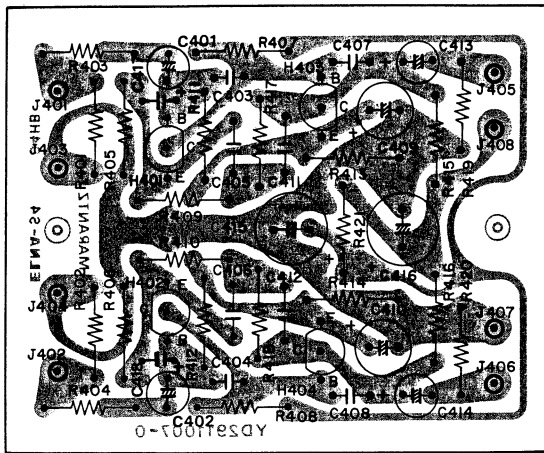

Figure 7. Phono Amplifier Assembly P400
Component Locations

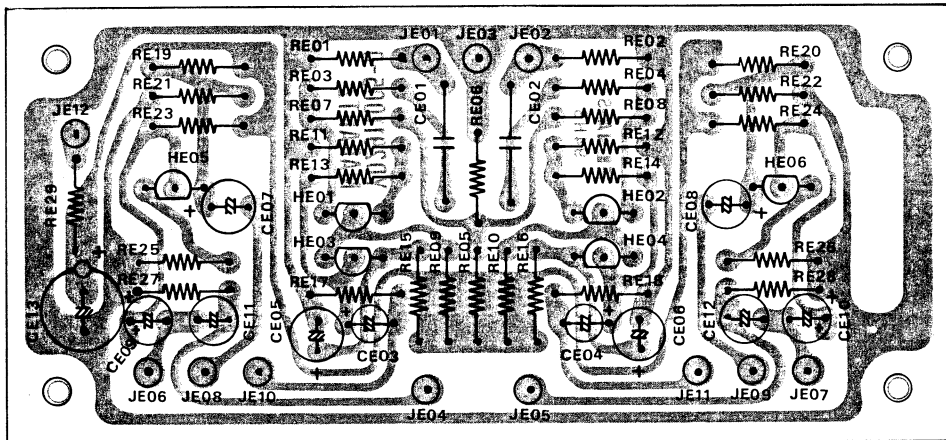

Figure 8. Tone Amplifier Assembly PE01 Component Locations

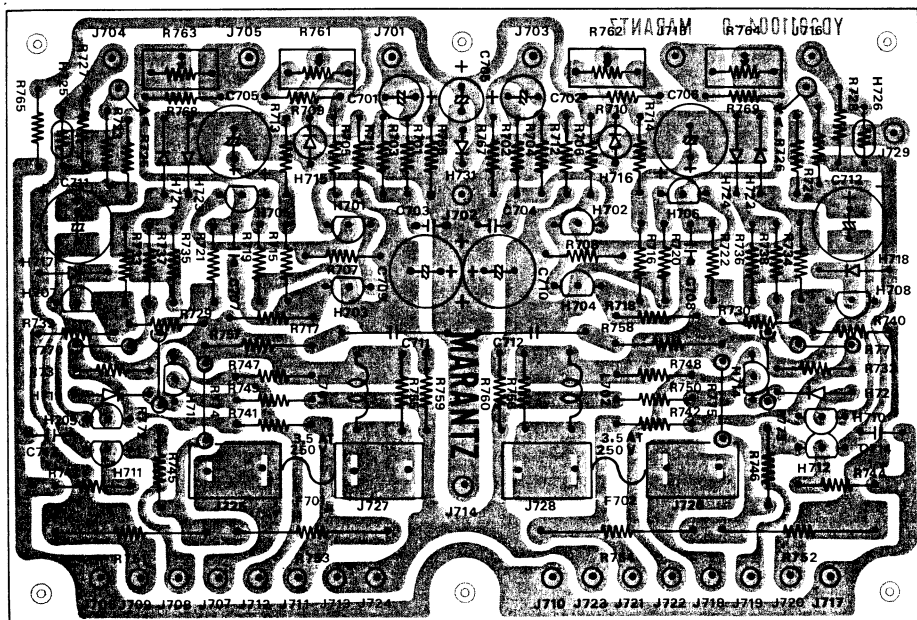

Figure 9. Main Amplifier Assembly P700 Component Locations

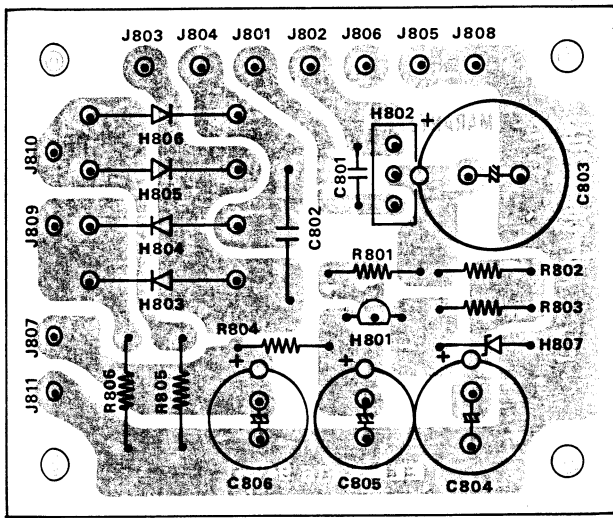

Figure 10. Power Supply Assembly P800
Component Locations

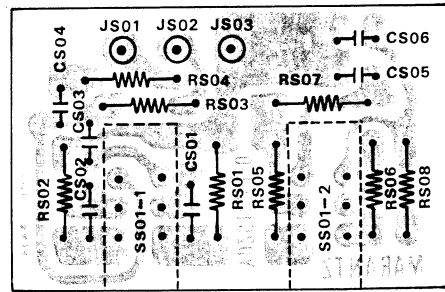

Figure 11. Loudness and Hi Filter Switch
Assembly PS01 Component Locations

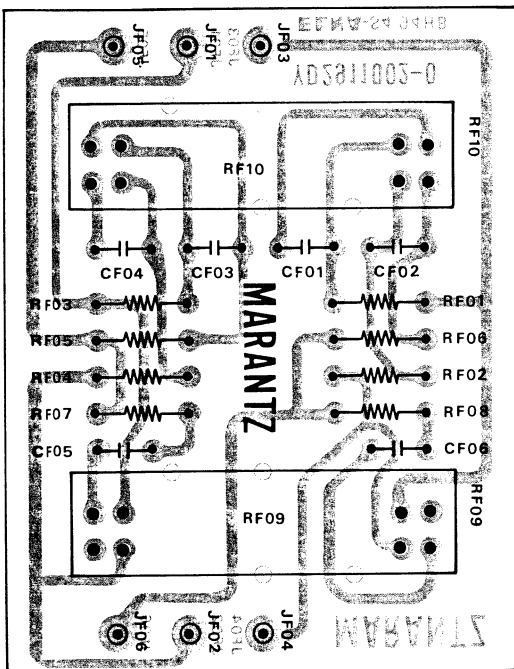

Figure 13. Tone Control Assembly PF01
Component Locations

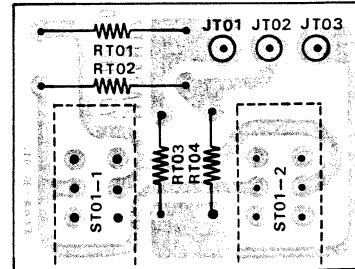

Figure 12. Speaker Switch
Assembly PT01 Component
Locations

NOTE

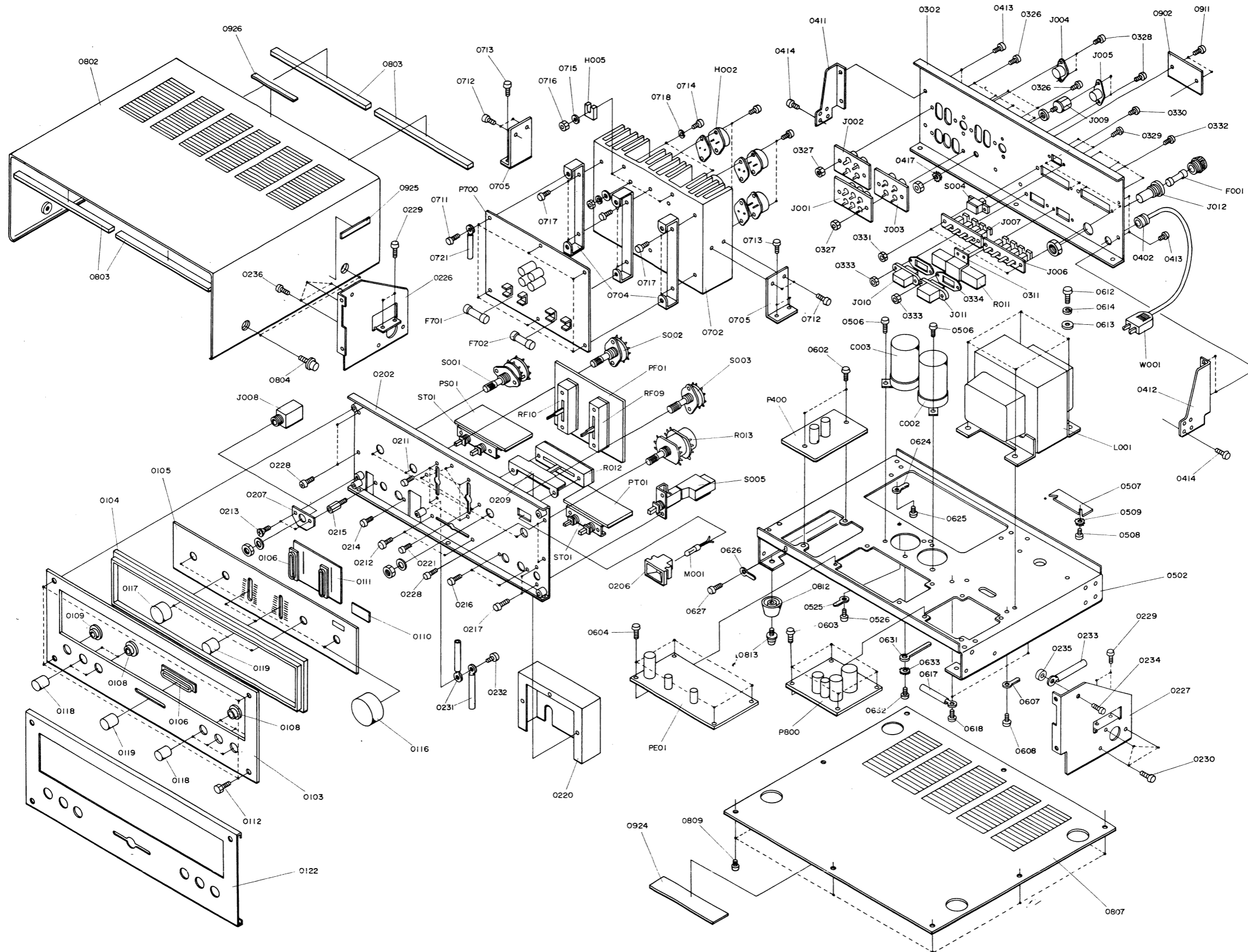
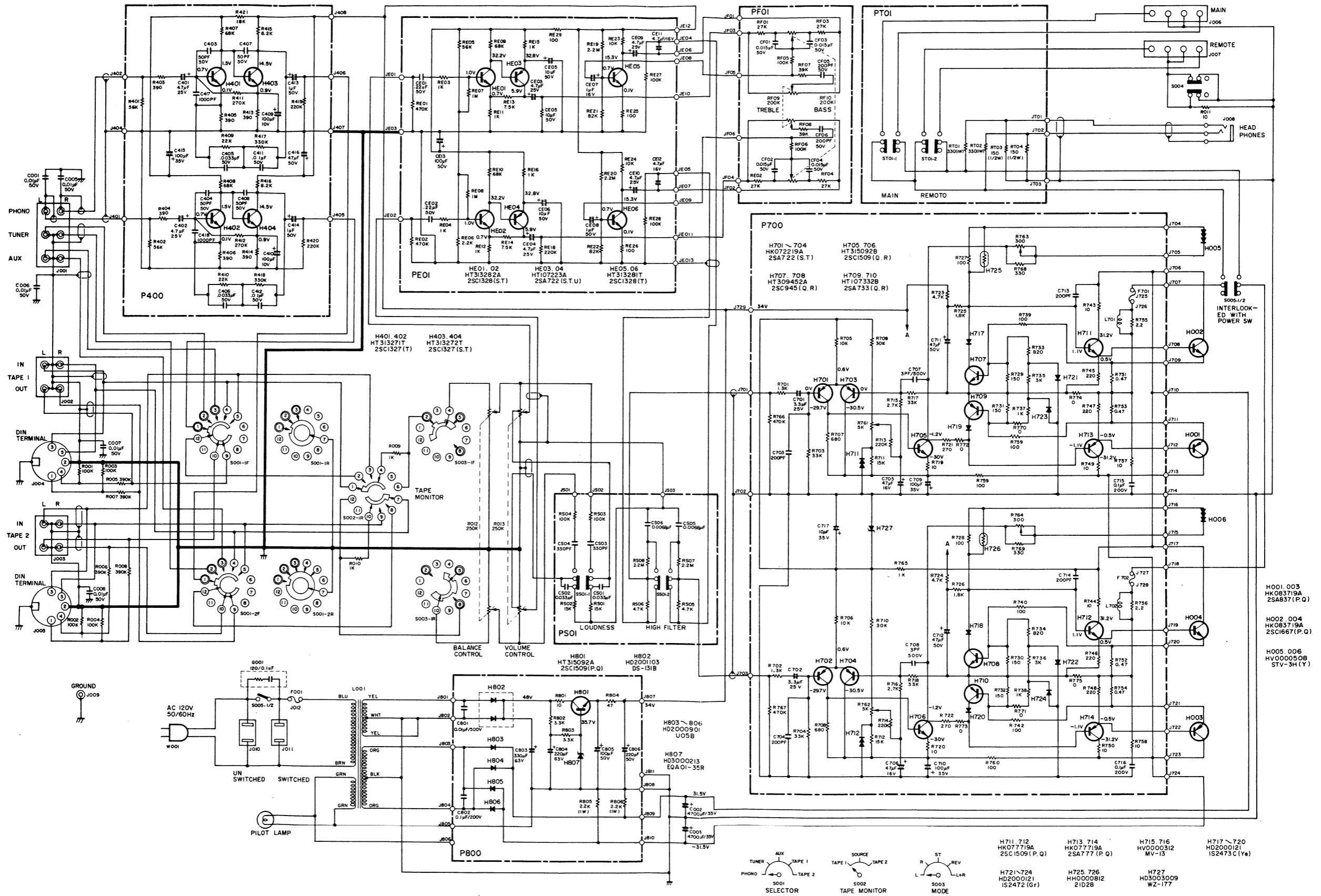

Figure 14. Exploded Mechanical Diagram



9. PARTS LIST

REF. DESIG.	PART NO.	DESCRIPTION	REF. DESIG.	PART NO.	DESCRIPTION
A	291106340	Front Panel Assembly	H404	HT313272A	Transistor, 2SC 1327 (S.T)
0103	291106301	Escutcheon	J401	YP1000113	Plug
0104	291240101	Frame	J402	YP1000113	Plug
0105	291106302	Escutcheon	J403	YP1000113	Plug
0106	285025901	Bush x 2	J404	YP1000113	Plug
0107	285425901	Bush	J405	YP1000113	Plug
0108	288625901	Bush x 5	J406	YP1000113	Plug
0109	273125901	Bush	J407	YP1000113	Plug
0110	291205303	Cover	J408	YP1000113	Plug
0111	292630301	Mask	0626	62030039W	Lug
0122	291105301	Cover			
		PHONO AMP. CIRCUIT BOARD-P400			TONE AMP. CIRCUIT BOARD-PE01
P400	YD2911007	P.W. Board, Phono Amp. (Print Only)	PE01	YD2911005	P.W. Board, Tone Amp. (Print Only)
	ZZ2911007	P.W. Board Assembly		ZZ2911005	P.W. Board Assembly
		P400—RESISTORS			PE01—RESISTORS
		All resistors are ±5% and ¼W.			All resistors are ±5%, and ¼W.
R401	RT0556314	56KΩ	RE01	RT0547414	470KΩ
R402	RT0556314	56KΩ	RE02	RT0547414	470KΩ
R403	RT0539114	390Ω	RE03	RT0510214	1KΩ
R404	RT0539114	390Ω	RE04	RT0510214	1KΩ
R405	RT0539114	390Ω	RE05	RT0556314	56KΩ
R406	RT0539114	390Ω	RE06	RT0522214	2.2KΩ
R407	RN0568314	68KΩ	RE07	RN0510514	1MΩ
R408	RN0568314	68KΩ	RE08	RN0510514	1MΩ
R409	RT0522314	22KΩ	RE09	RT0568314	68KΩ
R410	RT0522314	22KΩ	RE10	RT0568314	68KΩ
R411	RN0527414	270KΩ	RE11	RT0510214	1KΩ
R412	RN0527414	270KΩ	RE12	RT0510214	1KΩ
R413	RT0539114	390Ω	RE13	RT0575214	7.5KΩ
R414	RT0539114	390Ω	RE14	RT0575214	7.5KΩ
R415	RT0582214	8.2KΩ	RE15	RT0510214	1KΩ
R416	RT0582214	8.2KΩ	RE16	RT0510214	1KΩ
R417	RN0533414	330KΩ	RE17	RT0522414	220KΩ
R418	RN0533414	330KΩ	RE18	RT0522414	220KΩ
R419	RT0522414	220KΩ	RE19	RT0522514	2.2MΩ
R420	RT0522414	220KΩ	RE20	RT0522514	2.2MΩ
R421	RT0518314	18KΩ	RE21	RT0568314	68KΩ
		P400—CAPACITORS	RE22	RT0568314	68KΩ
C401	EE4750251	Electroly, 4.7μF ±20%, 25V	RE23	RT0510314	10KΩ
C402	EE4750251	Electroly, 4.7μF ±20%, 25V	RE24	RT0510314	10KΩ
C403	DD1650001	Ceramic, 50PF ±10%, 50V	RE25	RT0510114	100Ω
C404	DD1650001	Ceramic, 50PF ±10%, 50V	RE26	RT0510114	100Ω
C405	DF1633205	Film, 0.0033μF ±10%, 50V	RE27	RT0510414	100KΩ
C406	DF1633205	Film, 0.0033μF ±10%, 50V	RE28	RT0510414	100KΩ
C407	DD1650001	Ceramic, 50PF ±10%, 50V	RE29	RT0510114	100Ω
C408	DD1650001	Ceramic, 50PF ±10%, 50V			
C409	EA1070109	Electroly, 100μF +100%, -10%, 10V	CE01	DF1722405	Film, 0.22μF ±20%, 50V
C410	EA1070109	Electroly, 100μF +100%, -10%, 10V	CE02	DF1722405	Film, 0.22μF ±20%, 50V
C411	DF1610305	Film, 0.01μF ±10%, 50V	CE03	EE4750251	Electroly, 4.7μF ±20%, 25V
C412	DF1610305	Film, 0.01μF ±10%, 50V	CE04	EE4750251	Electroly, 4.7μF ±20%, 25V
C413	EE1050501	Electroly, 1μF ±20%, 50V	CE05	EA1060509	Electroly, 10μF +100%, -20%, 50V
C414	EE1050501	Electroly, 1μF ±20%, 50V	CE06	EA1060509	Electroly, 10μF +100%, -20%, 50V
C415	EA1070359	Electroly, 100μF +100%, -10%, 35V	CE07	EE1050501	Electroly, 1μF ±20%, 50V
C416	EA4760509	Electroly, 47μF +100%, -10%, 50V	CE08	EE1050501	Electroly, 1μF ±20%, 50V
C417	DK1610201	Ceramic, 1000PF	CE09	EE4750251	Electroly, 4.7μF ±20%, 25V
C418	DK1610201	Ceramic, 1000PF	CE10	EE4750251	Electroly, 4.7μF ±20%, 25V
		P400—MISCELLANEOUS	CE11	EQ4750161	Electroly, 4.7μF ±30%, 16V
H401	HT313271T	Transistor, 2SC1327(T)	CE12	EQ4750161	Electroly, 4.7μF ±30%, 16V
H402	HT313271T	Transistor, 2SC1327(T)	CE13	EA1070509	Electroly, 100μF +50%, -20%, 50V
H403	HT313272A	Transistor, 2SC1327(S.T)			

REF. DESIG.	PART NO.	DESCRIPTION
PE01-MISCELLANEOUS		
HE01	HT313282A	Transistor, 2SC1328 (S.T)
HE02	HT313282A	Transistor, 2SC1328 (S.T)
HE03	HT107223A	Transistor, 2SA722 (S.T.U)
HE04	HT107223A	Transistor, 2SA722 (S.T.U)
HE05	HT313281T	Transistor, 2SC1328 (T)
HE06	HT313281T	Transistor, 2SC1328 (T)
JE01	YP1000113	Plug
JE02	YP1000113	Plug
JE03	YP1000113	Plug
JE04	YP1000113	Plug
JE05	YP1000113	Plug
JE06	YP1000113	Plug
JE07	YP1000113	Plug
JE08	YP1000113	Plug
JE09	YP1000113	Plug
JE10	YP1000113	Plug
JE11	YP1000113	Plug
JE12	YP1000113	Plug
0711	51100306A	B.H.M. Screw x 6 B3 x 6
P700	YD2911004 ZZ2911004	MAIN AMP. CIRCUIT BOARD-P700 P.W. Board, Main Amp. (Print Only) P.W. Board Assembly
RESISTORS		
All resistors are $\pm 5\%$ and $\frac{1}{4}W$, unless otherwise indicated.		
R701	RT0513214	1.3K Ω
R702	RT0513214	1.3K Ω
R703	RT0533314	33K Ω
R704	RT0533314	33K Ω
R705	RT0510314	10K Ω
R706	RT0510314	10K Ω
R707	RT0568114	680 Ω
R708	RT0568114	680 Ω
R709	RT0530314	30K Ω
R710	RT0530314	30K Ω
R711	RT0515314	15K Ω
R712	RT0515314	15K Ω
R713	RT0522414	220K Ω
R714	RT0522414	220K Ω
R715	RT0527214	2.7K Ω
R716	RT0527214	2.7K Ω
R717	RT0533314	33K Ω
R718	RT0533314	33K Ω
R719	RT0510014	10 Ω
R720	RT0510014	10 Ω
R721	RT0527114	270 Ω
R722	RT0527114	270 Ω
R723	GF0547214	4.7K Ω
R724	GF0547214	4.7K Ω
R725	GF0518214	1.8K Ω
R726	GF0518214	1.8K Ω
R727	RT0510114	100 Ω
R728	RT0510114	100 Ω
R729	GF0515114	150 Ω
R730	GF0515114	150 Ω
R731	GF0515114	150 Ω
R732	GF0515114	150 Ω
R733	RT0582114	820K Ω

REF. DESIG.	PART NO.	DESCRIPTION
R734	RT0582114	820K Ω
R735	RT0530214	1.3K Ω
R736	RT0530214	1.3K Ω
R737	RT0510214	1K Ω
R738	RT0510214	1K Ω
R739	GF0510114	100 Ω
R740	GF0510114	100 Ω
R741	GF0510114	100 Ω
R742	GF0510114	100 Ω
R743	GF0510014	10 Ω
R744	GF0510014	10 Ω
R745	GF0522114	220 Ω
R746	GF0522114	220 Ω
R747	GF0522114	220 Ω
R748	GF0522114	220 Ω
R749	GF0510014	10 Ω
R750	GF0510014	10 Ω
R751	GW1047202	0.47 Ω $\pm 10\%$, 2W
R752	GW1047202	0.47 Ω $\pm 10\%$, 2W
R753	GW1047202	0.47 Ω $\pm 10\%$, 2W
R754	GW1047202	0.47 Ω $\pm 10\%$, 2W
R755	RC1002212	2.2 Ω $\pm 10\%$, $\frac{1}{2}W$
R756	RC1002212	2.2 Ω $\pm 10\%$, $\frac{1}{2}W$
R757	BT0510002	10 Ω $\pm 5\%$, 2W
R758	GT0510002	10 Ω $\pm 5\%$, 2W
R759	GF0510114	100 Ω
R760	GF0510114	100 Ω
R761	RA0502017	Trimming, 5K Ω $\pm 20\%$
R762	RA0502017	Trimming, 5K Ω $\pm 20\%$
R763	RA0301002	Trimming, 300 Ω $\pm 20\%$
R764	RA0301002	Trimming, 300 Ω $\pm 20\%$
R765	GF0510214	1K Ω
R766	RT0547414	470K Ω
R767	RT0547414	470K Ω
R768	RT0533114	330 Ω
R769	RT0533114	330 Ω
R770	RC0000012	0 Ω
R771	RC0000012	0 Ω
R772	RC0000012	0 Ω
R773	RC0000012	0 Ω
R774	RC0000012	0 Ω
R775	RC0000012	0 Ω
P700-CAPACITORS, COILS & FUSES		
C701	EE3350251	Electroly, 3.3 μF , 25V
C702	EE3350251	Electroly, 3.3 μF , 25V
C703	DD1620101	Ceramic, 200PF $\pm 10\%$
C704	DD1620101	Ceramic, 200PF $\pm 10\%$
C705	EE4760161	Electroly, 47 μF , 16V
C706	EE4760161	Electroly, 47 μF , 16V
C707	DD1003050	Ceramic, 3PF, 500V
C708	DD1003050	Ceramic, 3PF, 500V
C709	EA1070359	Electroly, 100 μF , 35V
C710	EA1070359	Electroly, 100 μF , 35V
C711	EA4760509	Electroly, 47 μF , 50V
C712	EA4760509	Electroly, 47 μF , 50V
C713	DD1620101	Ceramic, 200PF $\pm 10\%$
C714	DD1620101	Ceramic, 200PF $\pm 10\%$
C715	DF1710452	Ceramic, 0.1 μF , 200V
C716	DF1710452	Ceramic, 0.1 μF , 200V
C717	EA1060359	Electroly, 10 μF , 35V
L701	LC2272001	Coil, 2.7 μH

REF. DESIG.	PART NO.	DESCRIPTION
L702	LC2272001	Coil, 2.7μH
F701	FS1035001	Fuse, 3.5A, 250V(UL)
F702	FS1035001	Fuse, 3.5A, 250V(UL)
P700—SEMICONDUCTORS		
H701	HT107221S	Transistor, 2SA722 (S.T)
H702	HT107221S	Transistor, 2SA722 (S.T)
H703	HT107221S	Transistor, 2SA722 (S.T)
H704	HT107221S	Transistor, 2SA722 (S.T)
H705	HT315092B	Transistor, 2SC1509 (Q.R)
H706	HT315092B	Transistor, 2SC1509 (Q.R)
H707	HT309452A	Transistor, 2SC945 (Q.R)
H708	HT309452A	Transistor, 2SC945 (Q.R)
H709	HT107332B	Transistor, 2SA733 (Q.R)
H710	HT107332B	Transistor, 2SA733 (Q.R)
H711	HT315091P	Transistor, 2SC1509 (P.Q)
H712	HT315091P	Transistor, 2SC1509 (P.Q)
H713	HT107771P	Transistor, 2SA777 (P.Q)
H714	HT107771P	Transistor, 2SA777 (P.Q)
H715	HV0000312	Varistor, MV-13
H716	HV0000312	Varistor, MV-13
H717	HD2000121	Diode, 1S2473C (Ye)
H718	HD2000121	Diode, 1S2473C (Ye)
H719	HD2000121	Diode, 1S2473C (Ye)
H720	HD2000121	Diode, 1S2473C (Ye)
H721	HD2000221	Diode, 1S2472 (Gr.)
H722	HD2000221	Diode, 1S2472 (Gr.)
H723	HD2000221	Diode, 1S2472 (Gr.)
H724	HD2000221	Diode, 1S2472 (Gr.)
H725	HH0000812	Thermistor, 21D28
H726	HH0000812	Thermistor, 21D28
H727	HD3003009	Diode WZ-177
P700—MISCELLANEOUS		
J701	YP1000114	Plug
J724		
J725		
J728	YJ0800021	Socket
J729	YP1000114	Plug
GENERAL MISCELLANEOUS		
H001	HT108371P	Transistor, 2SA837 P:Q
H002	HT316671P	Transistor, 2SC1667 P:Q
H003	HT108371P	Transistor, 2SA837 P:Q
H004	HT316671P	Transistor, 2SC1667 P:Q
H005	HV0000508	Varistor, STV-3H (Y)
H006	HV0000508	Varistor, STV-3H (Y)
0702	291126701	Heat-Sink
0704	286716001	Bracket x3
0705	291116004	Bracket x2
0712	51380306P	P.H.Tap Screw x 4 P 3 x 6 T
0714	51440314A	B.H.M. Screw S x 2 B 3 x 14
0715	54020301A	Flat Washer P x 2
0716	53110303A	Hexagon Nut x 2
0717	51380306P	P.H. Tap Screw x 6 P 3 x 6 T
0525	62030039W	Lug
0721	138200503	Clamper

REF. DESIG.	PART NO.	DESCRIPTION
P800	YD2911003	POWER SUPPLY CIRCUIT BOARD—P800
	ZZ2911003	P.W. Board, Power Supply (Print Only)
		P.W. Board Assembly
P800—RESISTORS		
R801	GF0510014	10Ω ±5%, ¼W
R802	GF0533214	3.3KΩ ±5%, ¼W
R803	GF0533214	3.3KΩ ±5%, ¼W
R804	GF0547014	47Ω ±5%, ¼W
R805	GJ0522201	2.2KΩ ±5%, 1W
R806	GJ0522201	2.2KΩ ±5%, 1W
P800—CAPACITORS		
C801	DK1810351	Ceramic, 0.01μF +100%, -0%, 500V
C802	DF1710452	Film, 0.1μF, 200V
C803	EA3370631	Electroly, 330μF, 63V
C804	EA2270631	Electroly, 220μF, 63V
C805	EA1070509	Electroly, 100μF, 50V
C806	EA2270509	Electroly, 220μF, 50V
P800—SEMICONDUCTORS		
H801	HT315092A	Transistor, 2SC1509 (P.Q)
H802	HD2001103	Diode, DS-131B
H803	HD2000901	Diode, U05B
H804	HD2000901	Diode, U05B
H805	HD2000901	Diode, U05B
H806	HD2000901	Diode, U05B
H807	HD3000213	Diode, U05B
P800—MISCELLANEOUS		
J801	YP1000113	Plug
J811		
0607	62030039W	Lug
GENERAL MISCELLANEOUS		
0202	291216050	Bracket K
0206	291225901	Bush
0209	291210903	Shield
0211	51102605A	B.H.M. Screw x 4 B 2.6 x 5
0212	51100305A	B.H.M. Screw x 2
0213	51040304A	F.H.M. Screw x 2 F 3 x 4
0214	51100305A	B.H.M. Screw B 3 x 5
0215	291210102	Support
0216	51100306A	B.H.M. Screw x 2 B 3 x 6
0217	51100306A	B.H.M. Screw x 2 B 3 x 6
0220	291210904	Shield
0221	51100306A	B.H.M. Screw x 3 B 3 x 6
0226	282816013	Bracket
0227	282816014	Bracket
0228	51100306A	B.H.M. Screw B 3 x 6
0232	51100306A	B.H.M. Screw B 3 x 6
0234	51100306A	B.H.M. Screw B 3 x 6
0235	53110303A	Hexagon Nut
J008	YJ0100065	Jack, Headphone
0207	291212001	Insulator
LOUDNESS & HI FILTER SWITCH BOARD—PS01		
PS01	YD2911001	P.W. Board, Loudness & Hi Filter Switch (Print Only)

REF. DESIG.	PART NO.	DESCRIPTION
	ZZ2911001	P.W. Board Assembly
PS01—RESISTORS		
All resistors are ±5% and ¼W.		
RS01	RT0515314	15KΩ
RS02	RT0515314	15KΩ
RS03	RT0510414	100KΩ
RS04	RT0510414	100KΩ
RS05	RT0547214	4.7KΩ
RS06	RT0547214	4.7KΩ
RS07	RT0522514	2.2MΩ
RS08	RT0522514	2.2MΩ
PS01—CAPACITORS		
CS01	DF1633305	Film, 0.033μF ±10%
CS02	DF1633305	Film, 0.033μF ±10%
CS03	DK1633101	Ceramic, 330PF ±10%
CS04	DK1633101	Ceramic, 330PF ±10%
CS05	DF1668205	Film, 0.0068μF ±10%
CS06	DF1668205	Film, 0.0068μF ±10%
PS01—MISCELLANEOUS		
SS01	SP0202012	Shadow Switch
JS01	YP1000113	Plug
JS02	YP1000113	Plug
JS03	YP1000113	Plug
SPEAKER SWITCH BOARD—PT01		
PT01	YD2911006	P.W. Board, Speaker Switch (Print Only)
	ZZ2911006	P.W. Board Assembly
PT01—MISCELLANEOUS		
ST01	SP0202013	Shadow Switch, Main-Remoto
RT01	GJ0533101	Resistor, 330Ω±5%, 1W
RT02	GJ0533101	Resistor, 330Ω±5%, 1W
RT03	GF0515112	Resistor, 150Ω±5%, ¼W
RT04	GF0515112	Resistor, 150Ω±5%, ¼W
JT01	YP1000113	Plug
JT02	YP1000113	Plug
JT03	YP1000113	Plug
GENERAL MISCELLANEOUS		
S005	SP0301003	Pushswitch, Power
G001	BF1040002	Printed Comp., 120Ω+0.1μF1, For U.S.A.
R012	RS0254006	Variable Resist. 250KΩ, Balance
TONE CONTROL CIRCUIT BOARD—PF01		
PF01	YD2911002	P.W. Board, Tone Control (Print Only)
	ZZ2911002	P.W. Board Assembly
PF01—RESISTORS		
RF01	RT0527314	27KΩ ±5% ¼W
RF02	RT0527314	27KΩ ±5% ¼W
RF03	RT0527314	27KΩ ±5% ¼W
RF04	RT0527314	27KΩ ±5% ¼W
RF05	RT0510414	100KΩ ±5% ¼W
RF06	RT0510414	100KΩ ±5% ¼W
RF07	RT0539314	39KΩ ±5% ¼W
RF08	RT0539314	39KΩ ±5% ¼W

REF. DESIG.	PART NO.	DESCRIPTION
RF09	RS0204001	Variable, 200KΩ
RF10	RS0204001	Variable, 200KΩ
PF01—CAPACITORS & PLUGS		
CF01	DF1615305	Film Cap., 0.015μF ±10%, 50V
CF02	DF1615305	Film Cap., 0.015μF ±10%, 50V
CF03	DF1615305	Film Cap., 0.015μF ±10%, 50V
CF04	DF1615305	Film, 0.015μF ±10%, 50V
CF05	DD1620101	Ceramic Cap., 200PF ±10%, 50V
CF06	DD1620101	Ceramic Cap., 200PF ±10%, 50V
JF01	YP1000113	Plug
JF02	YP1000113	Plug
JF03	YP1000113	Plug
JF04	YP1000113	Plug
JF05	YP1000113	Plug
JF06	YP1000113	Plug
GENERAL MISCELLANEOUS		
S001	SR0405006	Potary Switch, Selector
S002	SR0203004	Rotary Switch, Tape Monitor
R009	RT0510214	Resistor, 1KΩ ±5%, ¼W
R010	RT0510214	Resistor, 1KΩ ±5%, ¼W
S003	SR0205008	Rotary Switch, Mode
R013	RM0254028	Variable Resist., 250KΩ (B), Volume
0231	138200503	Clamper x 2
0233	138200503	Clamper
M001	IN1008030	Lamp
W001	YC0240010	AC Cord, For U.S.A.
F001	FS1030006	Fuse, 250V, 3A (UL), For U.S.A.
0302	291116001	Bracket, For U.S.A.
0311	291100501	Clamper
0323	51100306S	B.H.M. Screw x 4, For U.S.A. B 3x6
0324	53110303A	Hexagon Nut x 4, For U.S.A.
0326	51100308S	B.H.M. Screw x 6 B 3 x 8
0327	53110303A	Hexagon Nut x 6
0328	51570306B	P.H. Tapt Screw x 4 P 3 x 6 ST
0329	51100306S	B.H.M. Screw x 2 B 3 x 6
0330	51100308S	B.H.M. Screw x 4 B 3 x 8
0331	53110303A	Hexagon Nut x 2
0332	51100308S	B.H.M. Screw x 4 B 3 x 8
0333	53110303A	Hexagon, Nut x 4
0334	289611801	Spacer x 2
0402	145525903	Bush, AC Cord, For U.S.A.
0411	282816003	Bracket
0412	282816004	Bracket
0413	51100306S	B.H.M. Screw x 4 B 3 x 6
0417	54050400R	T.L. Washer OR
S004	SS0202038	Slide Switch, Ambience
R001	RT0510414	Resistor, 100KΩ ±5%, ¼W
R002	RT0510414	Resistor, 100KΩ ±5%, ¼W
R003	RT0510414	Resistor, 100KΩ ±5%, ¼W
R004	RT0510414	Resistor, 100KΩ ±5%, ¼W
R005	RT0539414	Resistor, 390KΩ ±5%, ¼W
R006	RT0539414	Resistor, 390KΩ ±5%, ¼W
R007	RT0539414	Resistor, 390KΩ ±5%, ¼W
R008	RT0539414	Resistor, 390KΩ ±5%, ¼W
R011	GS1010015	Resistor, 10Ω ±10% 15W
J001	YT0206006	Terminal, Phono/Tuner/Aux
J002	YT0204008	Terminal, Tape 1
J003	YT0204008	Terminal, Tape 2
J004	YJ1100016	Socket, Tape 1 DIN
J005	YJ1100016	Socket, Tape 2 DIN

REF. DESIG.	PART NO.	DESCRIPTION
J006	YT0304006	Terminal, Speaker
J007	YT0304006	Terminal, Speaker
J009	YT0101003	Terminal, Ground
J010	YJ0400048	Socket, AC Outlet
J011	YJ0400048	Socket, AC Outlet
J012	YJ0800012	Socket, Fuse Holder, For U.S.A.
C006	DK1710301	Ceramic Cap., 0.01 μ F, 50V
C007	DK1710301	Ceramic Cap., 0.01 μ F, 50V
0624	62030039W	Lug
C001	DK1710301	Ceramic Cap., 0.01 μ F, 50V
C005	DK1710301	Ceramic Cap., 0.01 μ F, 50V
C008	DK1710301	Ceramic Cap., 0.01 μ F, 50V
0617	138200503	Clamper x 2
L001	TS1850209	Power Transf., For U.S.A.
C002	EC4780352	Electroly Cap., 4700 μ F, 35V
C003	EC4780352	Electroly Cap., 4700 μ F, 35V
0229	51570306B	P. H. Tapt Screw x 4 P 3 x 6 ST
0230	51100305A	B. H.M. Screw x 6 B 3 x 5
0414	51100306A	B. H.M. Screw x 8 B 3 x 6
0502	291110501	Chassis
0506	51570306B	P. H. Tapt Screw x 4 P 3 x 6 ST
0507	291116005	Bracket
0508	51570306B	P. H. Tapt Screw P 3 x 6 ST
0509	54050300R	T. L. Washer OR
0526	51570306B	P. H. Tapt Screw P 3 x 6 ST
0602	51570306B	P. H. Tapt Screw x 2 P 3 x 6 ST
0603	51570306B	P. H. Tapt Screw x 3 P 3 x 6 ST
0604	51570306B	P. H. Tapt Screw x 4 P 3 x 6 ST
0612	51570408B	P. H. Tapt Screw x 4 P 4 x 8 ST
0613	54020401A	Flat Washer P x 4
0614	54040402N	Spring Washer x 4
0618	51570306B	P. H. Tapt Screw x 2 P 3 x 6 ST
0625	51570306B	P. H. Tapt Screw P 3 x 6 ST
0629	51570306B	P. H. Tapt Screw P 3 x 6 ST
0631	121000501	Clamper
0632	51570306B	P. H. Tapt Screw P 3 x 6 ST
0633	54050300R	T. L. Washer OR
0713	51570306B	P. H. Tapt Screw x 4 P 3 x 6 ST
0812	275905701	Leg x 4
0813	51490410S	B. H. M. Screw F S x 4 B 4 x 10 F/S
0931	288686101	Label, Marantz
0112	52017039J	Bolt x 4
0116	282815401	Knob, Selector/Balance x 2
0117	282815402	Knob, Mode/Tape Mon. x 2
0118	281815401	Knob, Hi Filter/Loudness/Main/Remote/Power x 5
0119	285015401	Knob, Balance/Bass/Treble x 3
0802	282825701	Lid, Top
0803	257711807	Spacer x 4
0804	51480406S	B. H. M. Screw B 4 x 6 F
0807	282825702	Lid, Bottom
0809	51100406S	B. H. M. Screw F x 8 B 4 x 6 F
0902	291126501	Indicator, For U.S.A.
0911	51100305S	B. H. M. Screw x 2 B 3 x 5
0914	951091102	Label, UL Factor Code, For U.S.A.
0915	951120101	Label, UL, For U.S.A.
0924	257886101	Label, Caution to prevent
0925	257886102	Label, Do not remove cover.
0926	257886103	Label, See marking on botton.

REF. DESIG.	PART NO.	DESCRIPTION
1002	291185101	Instructions, Set, For U.S.A.
1011	291185601	Schematic Diagram, For U.S.A.
1020	281885104	Instructions, Packing
1021	282885108	Instructions, Accessories
1022	288585107	Instructions, Cabinet Mounting
1026	257785401	Guarantee Card
1027	257785102	Instructions
1028	257781301	Envelope, For U.S.A.
1102	291180101	Packing Case, Inner
1103	291180111	Packing Case, Outer
1108	289180301	Partitioner x 2
1112	901383033	Polyethylen Bag, Set
1114	901302501	Polyethylen Bag, Printed Matter
1117	102980401	Sleeve, AC Cord
1119	273182101	Silicagel x 2
1122	952281501	Serial No Card x 4, For U.S.A.

10. TECHNICAL SPECIFICATIONS

Gain — Phono (low level)	75 dB
Phono to recording output	37 dB
High level	38 dB
Input Impedance — Low level input	Phono 47 Kohms
— High level input	50 Kohms
Input Sensitivity — Phono (Low)	2.1 mV
Frequency Response	± 2 dB, 20 Hz to 20 kHz at rated power output
Intermodulation Distortion	Less than 0.3% at rated power output from 20 Hz to 20 kHz with both channels driven (S.M.P.T.E.)
Damping Factor	Greater than 20 into 8 ohms load
Total Noise — From magnetic phono input	Less than 2.5 μ V equivalent input at rated output into 8 ohms
Volume Tracking	Within 3 dB
Rated Power Output (Continuous average per channel, all channels driven.)	
Power Output	20 Watts 4 ohms
.....	20 Watts 8 ohms
.....	15 Watts 16 ohms
Power Band	20Hz to 20kHz
THD	0.3%

GENERAL

Power Requirements	120 Volts \sim 50/60Hz)
(This unit can be converted by a qualified technician to operate on 110/220/240 \sim 50/60Hz)	
Power Consumption — at rated power output, both channels operating	125 Watts
idling power (volume control at zero)	20 Watts
Dimensions — Panel Width	14-1/8 inches
— Panel Height	4-3/4 inches
— Depth	11 inches
Weight — Unit alone	16.4 lbs
— Packed for shipment	23.2 lbs

SERVICE INFORMATION FOR EUROPEAN MODEL

The information contained here in includes the rear panel and main chassis component locations, schematic diagram, parts list and voltage conversion.

For the circuit description, alignment method and repairing hints, refer to the original service manual.

TABLE OF CONTENTS

Rear Panel Adjustments and Facilities Locations	22
Main Chassis Component Locations (Top View)	22
Schematic Diagram	23~24
Voltage Conversion	25
Parts List	26

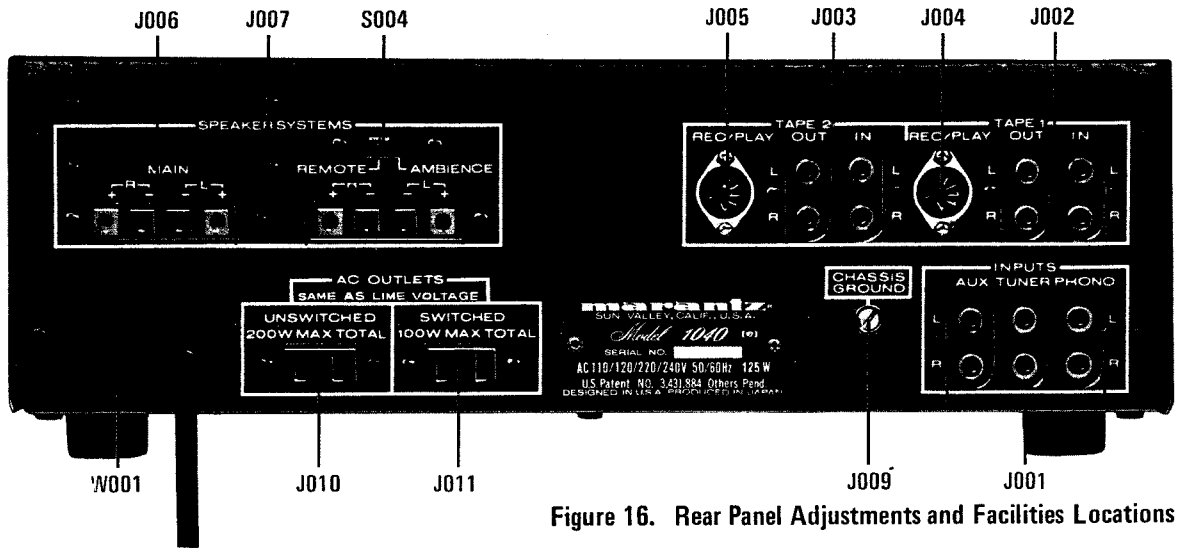

Figure 16. Rear Panel Adjustments and Facilities Locations

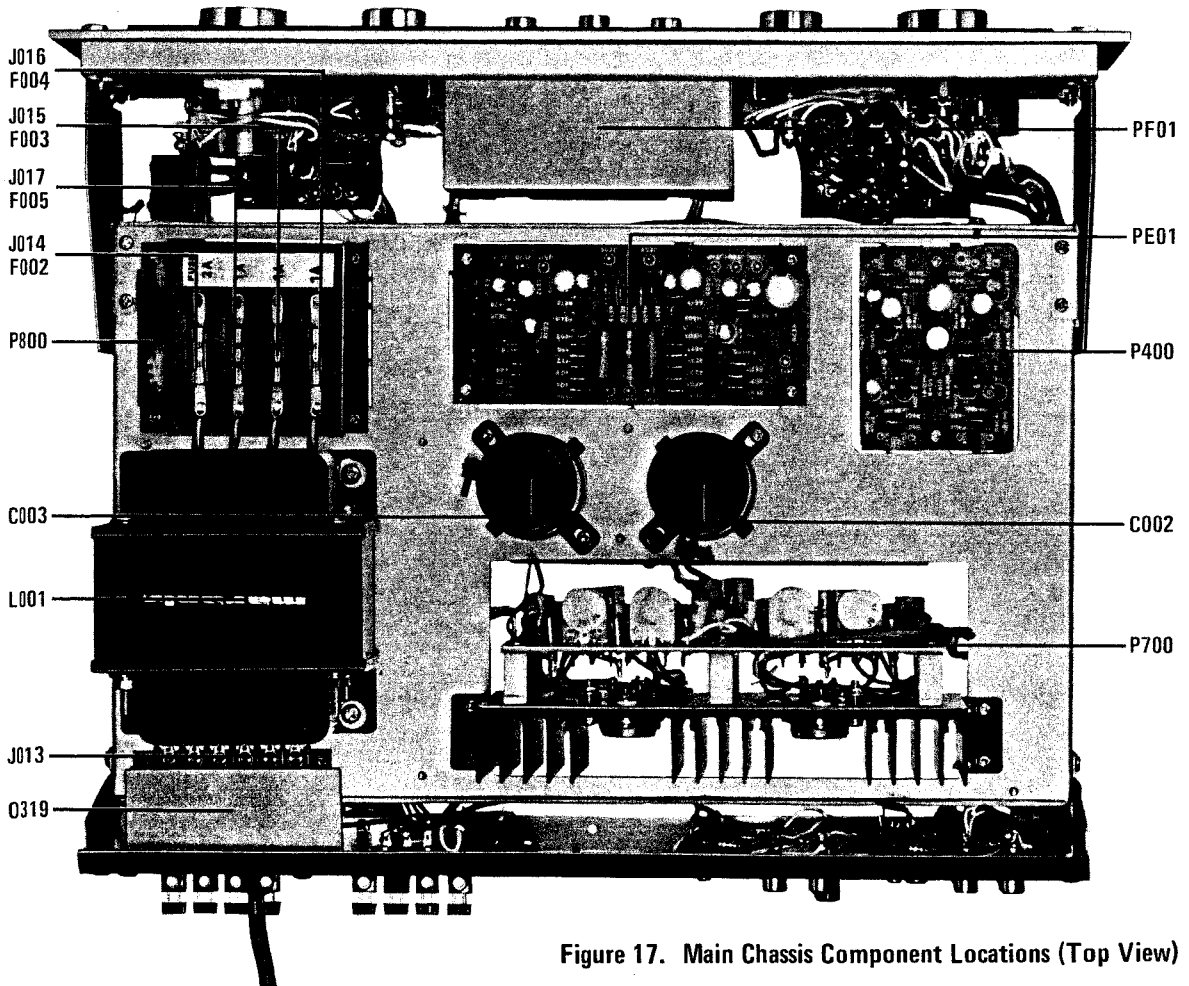

Figure 17. Main Chassis Component Locations (Top View)

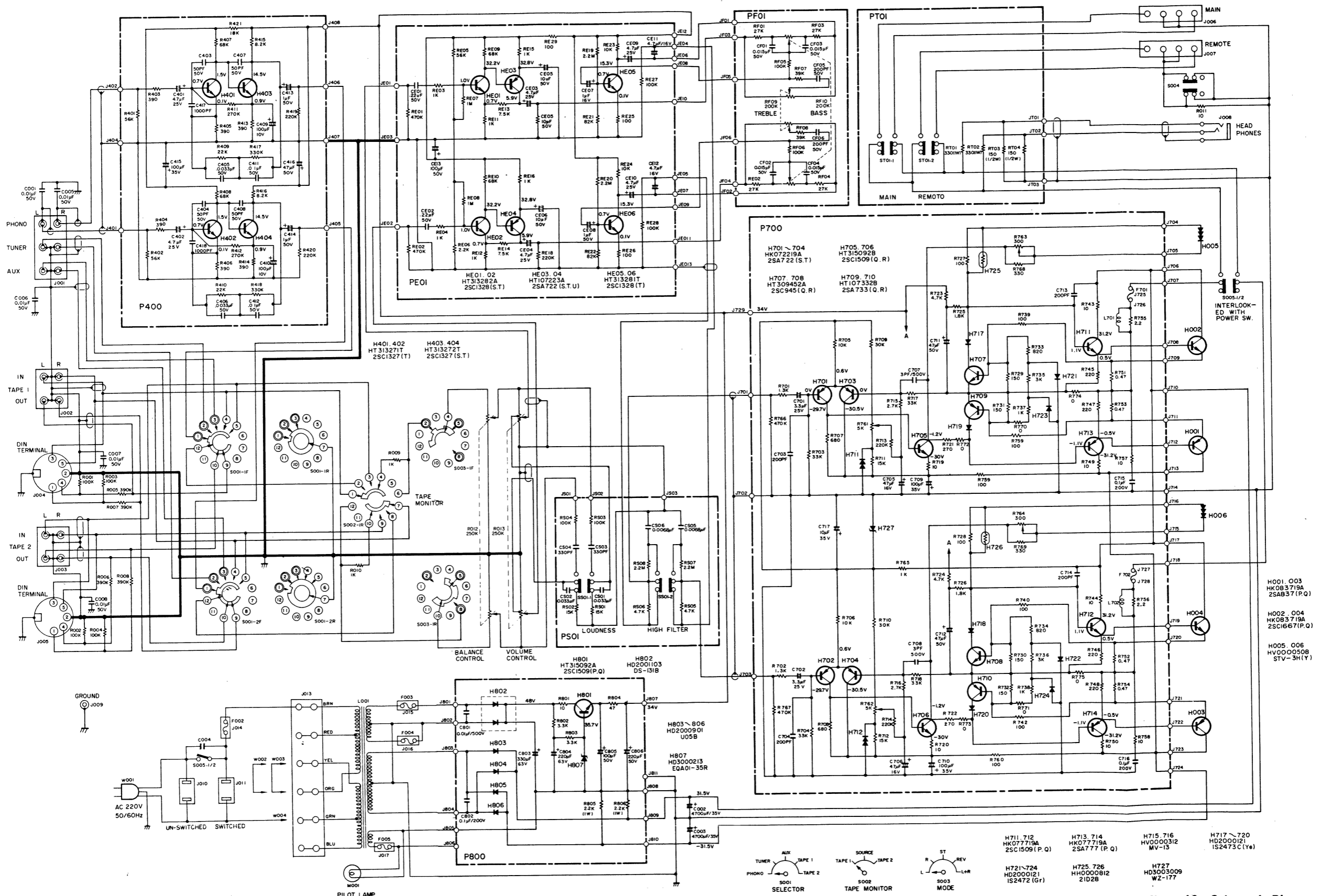

Figure 18. Schematic Diagram

VOLTAGE CONVERSION

This model is equipped with a universal power transformer to permit operation at 110, 120, 220 and 240 V AC 50 to 60 Hz.

To convert the unit to the required voltage perform the following steps:

- (1) Remove the lid (top).
- (2) Change the jumper wires as illustrated below for the required AC voltage.

CAUTION: DISCONNECT POWER SUPPLY CORD FROM AC OUTLET BEFORE CONVERTING VOLTAGE.

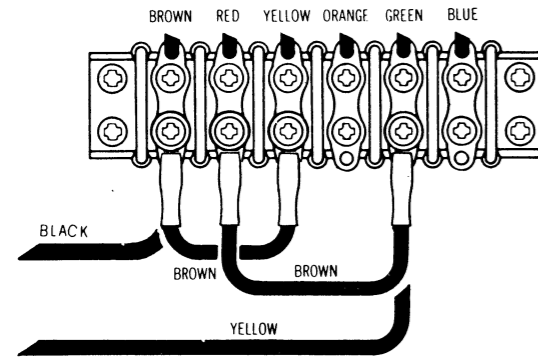

For 110V Operation

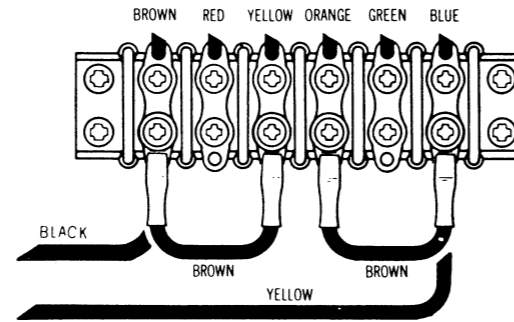

For 120V Operation

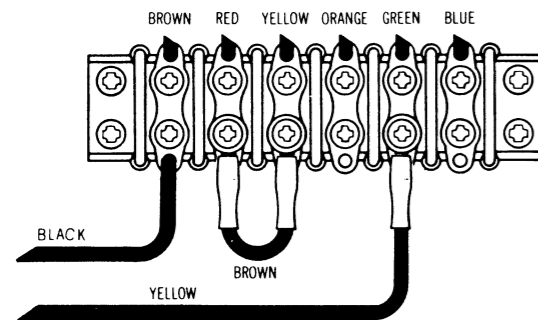

For 220V Operation

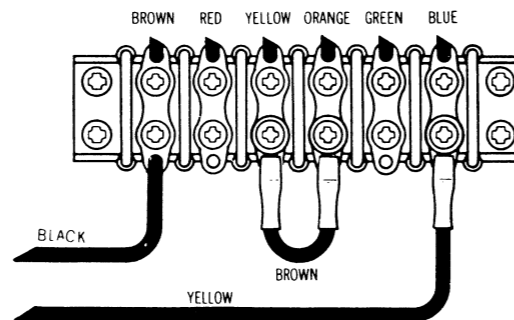

For 240V Operation

Figure 19. Voltage Conversion Chart

PARTS LIST

REF. DESIG.	PART NO.	DESCRIPTION
W001	YC0190003	AC Cord
0304	291116003	Bracket
0318	51100306S	B.H.M. Screw x 2 B 3 x 6
0321	51100306S	B.H.M. Screw x 2 B 3 x 6
0403	282125901	Bush, AC Cord
0404	53110303A	Hexagon Nut x 2
0405	54050300R	T.L. Washer OR x 2
0406	51060316A	B.H.M. Screw x 2 B 3 x 16
0407	55060305S	T.R. Rivet x 2
0408	284906702	Cap
J013	YL0106004	Terminal
W002	YB0007001	Connective Cord
W003	YB0007001	Connective Cord
W004	YB0027001	Connective Cord
0316	281816006	Bracket
0317	51100312A	B.H.M. Screw x 4 B 3 x 12
0319	282126902	Protector
0320	288912005	Insulator
0322	285412001	Insulator
J014	YJ0800009	Socket, Fuse Holder
J015	YJ0800009	Socket, Fuse Holder
J016	YJ0800009	Socket, Fuse Holder
J017	YJ0800009	Socket, Fuse Holder
0516	282816012	Bracket
0517	51100306A	B.H.M. Screw x 4 B 3 x 6
0518	53110303A	Hexagon Nut x 4
0930	291126510	Indicator, Ampere Label
1001	TS1850210	Power Transf.
F002	FS1020005	Fuse, 250V, 2A
F003	FS1010007	Fuse, 250V, 1A
F004	FS1010007	Fuse, 250V, 1A
0904	291126503	Indicator
1004	291185121	Instructions, Set
1012	291185602	Schematic Diagram
1024	281881301	Envelope
1118	956000004	Hang Tag, Voltage Indicator
1124	952301511	Serial NO. Card x 4

* To be used in the European Model Only.