

BUSH RADIO

Service Instructions

MAINS PORTABLE for A.C. or D.C. Supply MODEL D.A.C.90

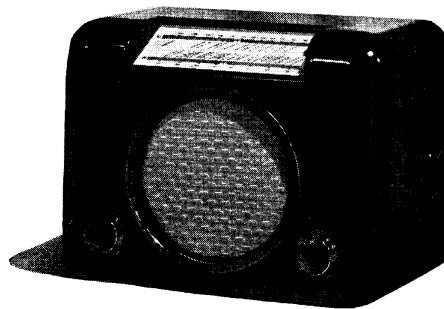

Front View of D.A.C 90 Receiver

INDEX TABLE.

Section	Page	Section	Page
Capacitors	3	Part Numbers	8
Circuit Alignment	7	Resistors	3
Circuit Description	6	Service Notes	8
Coils	5	Speaker	5
Coil and Frame Aerial connections	4	Specification	1
Drive, fitting wire	7	Valve operating data	6
Dismantling	6	Warning	2
Output Transformer	5		

SPECIFICATION.

BASIC DESIGN—

A five-valve (including rectifier), two waveband super-heterodyne, with six tuned circuits; self-contained frame aerial system incorporated, suitable for A.C. or D.C. supply mains 200–250 volts.

VALVES—

Mullard CCH.35 (Heater 7v.).
 EF.39 (Heater 6.3v.).
 EBC.33 (Heater 6.3v.).
 CL.33 (Heater 33v.).
 CY.31 (Heater 20v.).

All valves Octal bases. Heater current 0.2 amp.

SCALE LAMP—

Type 6.2 volt, 0.3 amp. A lamp of this current rating only should be used when replacing.

VOLTAGE ADJUSTMENT—

A.C. or D.C. Supply mains of voltages:—
 200–210—Place Red plug into Socket 210.
 211–230—Place Red plug into Socket 230.
 231–250—Place Red plug into Socket 250.

MAINS CONSUMPTION—

Approximately 60 watts at 230 volts.

AUDIO OUTPUT—

1.5 watts to the Speaker.

WAVEBAND RANGES—

Medium: 190–560 metres (1,579–535.7 kcs.).
 Long: 900–2,000 „ (333.3–150 kcs.).

INTERMEDIATE FREQUENCY—

465 kcs.

CONTROLS—

Facing front of set, from left to right:—
 ON/OFF switch and volume.
 Waveband switch, turn right for Long Waveband.
 Tuning (on side of cabinet).

MAINS CONNECTION—

A detachable mains lead is provided which should be plugged into the 2-pin 5 amp. connectors on the right-hand side of the chassis (facing the back of cabinet).

CABINET DIMENSIONS (including knobs)—

Height 9½ ins. Depth 7½ ins. Length 12½ ins.

WEIGHT—

Approximately 10 lbs.

CIRCUIT DIAGRAM D.A.C.90

D.A.C.90

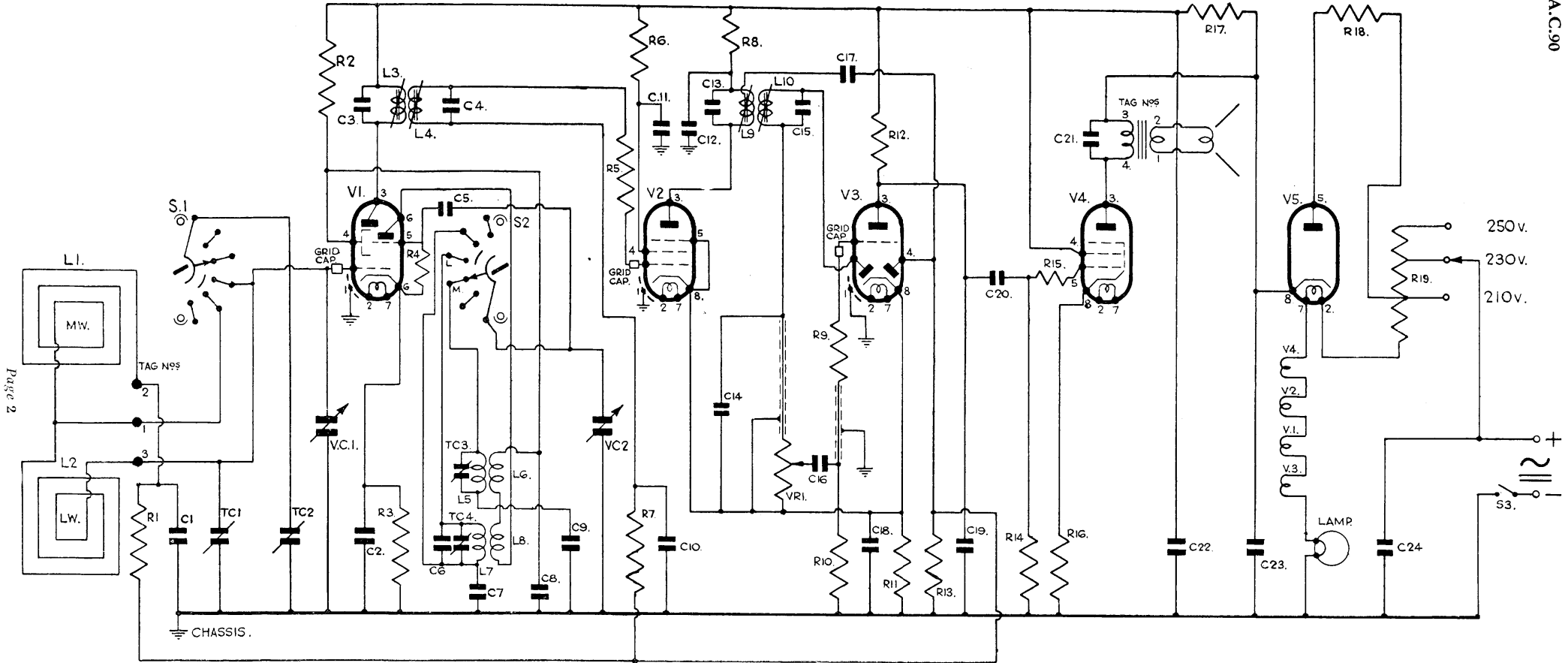

Page 2

VALVES.

- V.1. Mullard CCH.35. 8-pin octal base—Frequency Changer.
- V.2. Mullard EF.39. 8-pin octal base—Intermediate Frequency Amplifier.
- V.3. Mullard EBC.33. 8-pin octal base—Detector, A.V.C. Rectifier, and A.F. Amplifier.
- V.4. Mullard C.L.33. 8-pin octal base—Output Pentode.
- V.5. Mullard CY.31. 8-pin octal base—H.T. line Rectifier.

WARNING.

When servicing this Receiver, remember the chassis is connected to one side of the supply mains, and, therefore, under certain conditions will be "live."

Do not touch the chassis with an earth wire or connect any test equipment which may be earthed without first isolating it from the chassis by a capacitor, when working under these conditions.

RESISTORS.

Reference.	Value, Ohms.	Part No.	Description.
R. 1	1 meg.	P.7115	V.1. Control grid decoupling. A.V.C. line.
R. 2	15,000	P.6652	V.1. Screening grids and oscillator anode decoupling.
R. 3	100	P.6107	V.1. Cathode bias.
R. 4	33,000	P.6737	V.1. Oscillator control grid resistance.
R. 5	220	P.6191	V.2. Control grid stabilizer.
R. 6	47,000	P.6779	V.2. Screen decoupling.
R. 7	1 meg.	P.7115	V.2. Control grid decoupling. A.V.C. line.
R. 8	10,000	P.6610	V.2. Anode decoupling.
R. 9	100,000	P.9389A	V.3. Triode control grid stopper.
R.10	2.2 meg.	P.7199	V.3. Triode control grid load.
R.11	470	P.6275	V.2 and V.3. Common cathode bias.
R.12	68,000	P.6821	V.3. Triode anode load.
R.13	1 meg.	P.7115	V.3. A.V.C. diode load.
R.14	470,000	P.7031	V.4. Control grid load.
R.15	47,000	P.6779	V.4. Control grid stopper.
R.16	150	P.6155	V.4. Cathode bias.
R.17	10,000	P.6608	H.T. line smoothing.
R.18	150	P.6147	V.5. Anode current surge resistance.
R.19	600 + 100 + 100	P.3764	Heater circuit ballast.
V.R.1	500,000	P.12413	Volume control with S.3 ganged.

All fixed Resistors are rated at $\frac{1}{4}$ watt, with the exception of R.2 — $\frac{1}{2}$ watt, R. 17— 2 watt, R.18 — 1 watt, and R.19 — 30 watt.

A tolerance of ± 20 per cent. on resistance value is permissible on all fixed Resistors, with the exception of R.16 ± 10 per cent.

CAPACITORS.

Reference.	Value		Tolerance = %	Type.	Part No.	Description.
	mfd.	mmfd.				
C. 1	-.05	—	20	Tubular	P.12775 or P.3770	V.1. Control grid decoupling. A.V.C. line.
C. 2	-.05	—	20	"	"	V.1. Cathode by-pass.
C. 3		110	2	Silver Mica	P. 3729	1st I.F.T. primary capacity.
C. 4		110	2	" "	"	1st I.F.T. secondary capacity.
C. 5		50	20	Mica	P.3774	V.1 Oscillator control grid capacity.
C. 6		180	2	Silver Mica	P.12668	L.W. Oscillator tuning fixed capacity.
C. 7		390	1	" "	P.12669	L.W. Oscillator padding.
C. 8	-.05	—	20	Tubular	P.12775 or P.3770	V.1 Screens and Oscillator anode decoupling.
C. 9		605	1	Silver Mica	P.12670	M.W. Oscillator padding.
C.10	-.05	—	20	Tubular	P.12775 or P.3770	V.2 Control grid decoupling. A.V.C. line.
C.11	-.05	—	20	"	"	V.2 Screen decoupling.
C.12	-.05	—	20	"	"	V.2 Anode decoupling.
C.13		110	2	Silver Mica	P.3729	2nd I.F.T. primary capacity.
C.14		100	20	Mica	P.3775	I.F. by-pass.
C.15		110	2	Silver Mica	P.3729	2nd I.F.T. Secondary capacity.
C.16	-.01	—	20	Tubular	P.12773 or P.8988	A.F. Coupling from signal diode to triode grid.
C.17		50	20	Mica	P.3774	Coupling to A.V.C. diode.
C.18	-.05	—	20	Tubular	P.12775 or P.3770	V.2, V.3 Cathodes common by-pass.
C.19	-.006	—	20	"	P.12774 or P.12776	R.F. By-pass and fixed tone corrector.
C.20	-.01	—	20	"	P.12773 or P.8988	A.F. Coupling from V.3 triode to V.4 control grid.
C.21	-.01	—	20	"	"	Fixed tone corrector.
C.22	16	—	20	Electrolytic	P.12444	H.T. Smoothing.
C.23	32	—	20	"	"	"
C.24	-.1	—	20	Tubular	P.8998	Mains R.F. by-pass.
T.C.1		3—40	—	" Postage Stamp "	P.12466	M.W. Frame aerial trimmer.
T.C.2		3—40	—	" "	"	L.W. Frame aerial trimmer.
T.C.3		3—40	—	" "	"	M.W. Oscillator trimmer.
T.C.4		3—40	—	" "	P.2937A	L.W. Oscillator trimmer.
V.C.1		—	—	Gang Condenser	P.12422	Frame aerial circuit tuning.
V.C.2		—	—			Oscillator circuit tuning.

Note.—All Tubular capacitors are non-inductive type.

D.C. Working Voltage rating of all Capacitors is 350, with the exception of C.24, which is 500.

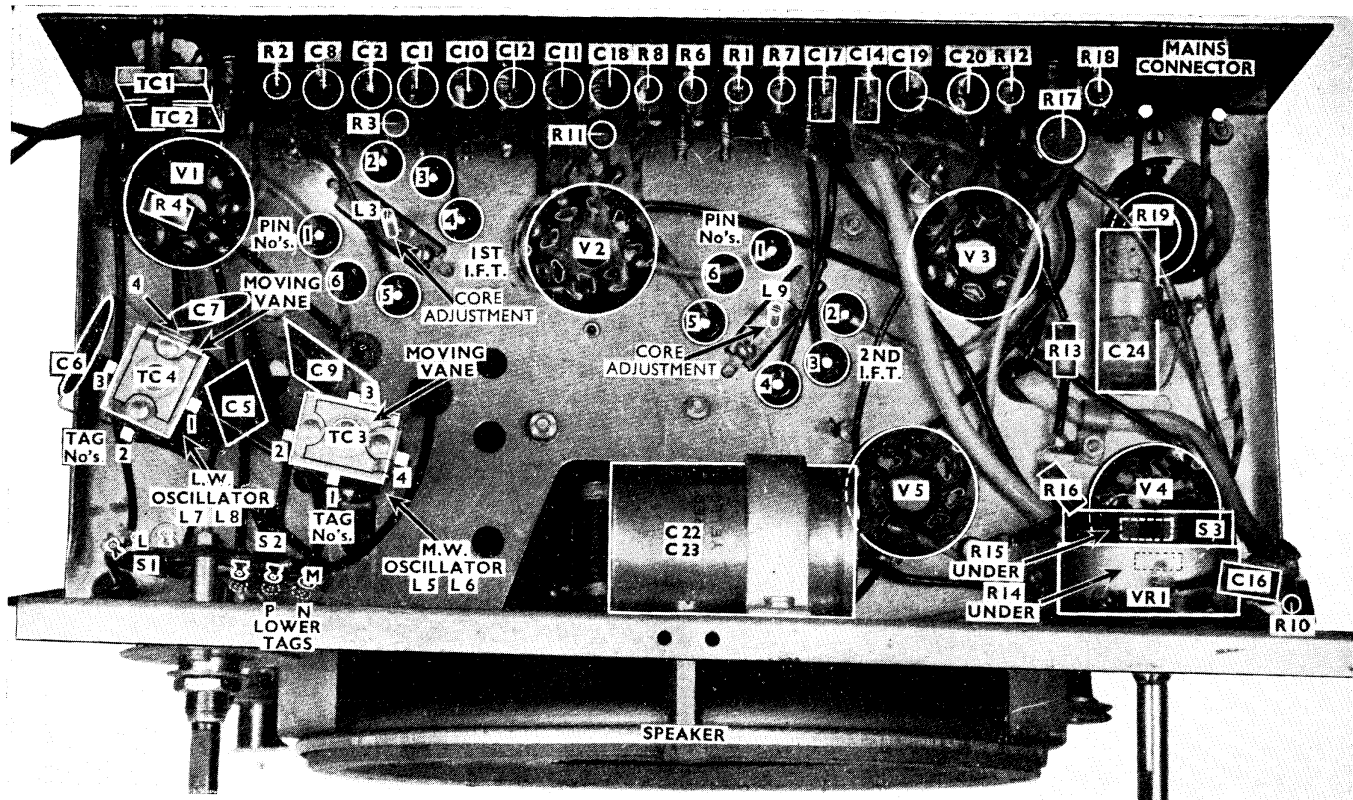

Under Chassis view of D.A.C.90 Receiver

CONNECTIONS TO INTERMEDIATE FREQUENCY TRANSFORMERS.

1st Intermediate Frequency Transformer— L.3., L.4.

- Pin 1. To V.1, pin 3.
- .. 2. Blank.
- .. 3. Blank.
- .. 4. To C.10.
- .. 5. To R.2.
- .. 6. Blank.

2nd Intermediate Frequency Transformer— L.9., L.10.

- Pin 1. To V.2, pin 3.
- .. 2. To V.3, pin 5.
- .. 3. To C.17.
- .. 4. To C.14.
- .. 5. To R.8.
- .. 6. Blank.

COIL AND FRAME AERIAL CONNECTIONS.

FRAME AERIAL CONNECTIONS—

- Tag No. 1. M.W.—L.W. junction—
Green lead to S.1., tag L.
- Tag No. 2. M.W. finish—
Blue lead to C.1., R.1.
- Tag No. 3. L.W. start—
Red lead to T.C.1., fixed vanes.

COIL CONNECTIONS—

The moving plate of the trimmers on the M.W. and L.W. oscillator coils is shown in the illustration, in order to facilitate the correct positioning of the tags when the replacement of a coil is necessary.

MEDIUM WAVEBAND OSCILLATOR L.5., L.6.

- Tag No. 1. L.6.—To L.8., tag 1
- Tag No. 2. L.5.—To S.2., tag M. T.C.3. fixed plate.
- Tag No. 3. L.6.—To V.1., pin 4.
- Tag No. 4. L.5.—C.9. connected, T.C.3 moving plate.

LONG WAVEBAND OSCILLATOR L.7., L.8.

- Tag No. 1. L.8.—To L.6., tag 1.
- Tag No. 2. L.7.—To S.2. tag N, C.6., T.C.4. fixed plate connected.
- Tag No. 3. L.8.—To V.1., pin 6.
- Tag No. 4. L.7.—C.6. and C.7., T.C.4. moving plate, S.2. tag P. connected.

COILS.

Ref.	Approx. Resistance ohms.	Tag Nos.	Part No.	Description.
L. 1	3	1 & 2	S.12718	M.W. section of frame aerial.
L. 2	4.5	1 & 3		L.W. frame aerial (together with L.1).
L. 3	5	1 & 5	S.9522	1st I.F.T. primary.
L. 4	5	4		1st I.F.T. secondary.
L. 5	1.6	2 & 4	S.12710	M.W. oscillator tuning.
L. 6	1.1	1 & 3		M.W. oscillator coupler.
L. 7	2.7	2 & 4	S.12711	L.W. oscillator tuning.
L. 8	2.2	1 & 3		L.W. oscillator coupler.
L. 9	5	1, 3, 5	S.9523	2nd I.F.T. primary.
L.10	5	2 & 4		2nd I.F.T. secondary.

OUTPUT TRANSFORMER.

PART No. S.12706.

D.C. RESISTANCE—

Primary—500 ohms. Secondary—0.75 ohms.

RATIO : 40 : 1.

INDUCTANCE—

Primary—6.4 henrys at 400 cycles 5 volts with 26 mA. D.C. flowing.

TAG NOS. :—

1. Start of Secondary winding.
2. Finish of Secondary winding.
3. Finish of Primary winding.
4. Start of Primary winding.

SPEAKER.

Types :—

ROLA 6Z, Part No. P.12768.

CELESTION 1022, 6 in. Part No. P.12498.

GOODMAN'S 6 in. Part No. P.12769.

SPEECH COIL D.C. RESISTANCE—Approx. 2.6 ohms.

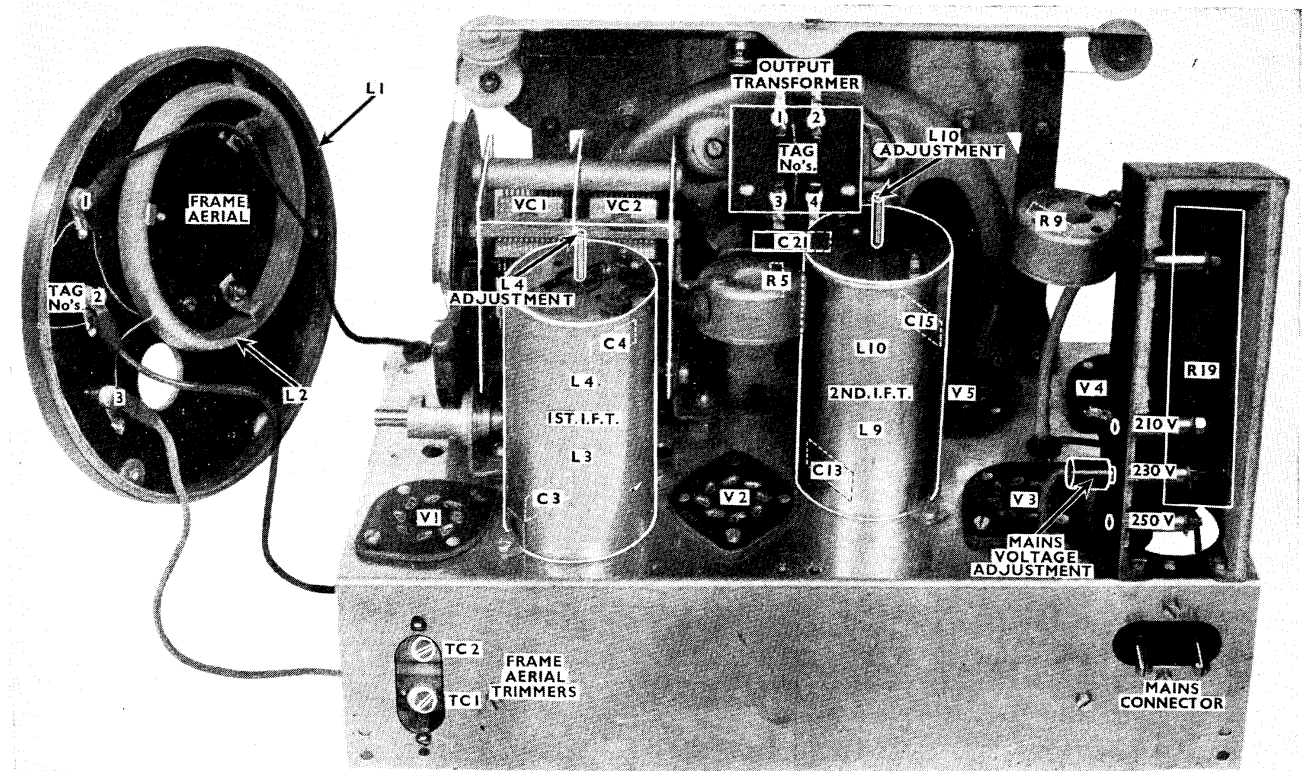

Top view of D.A.C.90 Chassis with Frame Aerial removed from Cabinet, showing Connections

CIRCUIT DESCRIPTION.

VALVE OPERATING DATA.

PRESELECTOR CIRCUIT—

The frame aerials L.1. (M.W.) and L.2. (L.W.) are connected in series; the hexode control grid of V.1. is connected to the L.W. section, tuning by V.C.1.

With S.1. in the Medium Waveband position, the L.W. section of the frame is short circuited; parallel trimming for the M.W. by T.C.1.

S.1. in the Long Waveband position L.1. (M.W.) becomes part of the L.W. tuned circuit with T.C.2. switched in across both sections of the frame, T.C.1. still remaining in parallel with the M.W. section.

The earth return for the frame aerial circuit is via C.1., which is part of the A.V.C. line decoupling to V.1.

FREQUENCY CHANGER—V.1. MULLARD CCH.35.

The signal frequency is applied to the Hexode control grid of this valve, with R.2. and C.8 providing the decoupling for the screening grids and triode oscillator anode. Cathode bias by R.3. with C.2. as by-pass.

The beat frequency is obtained by coupled coils L.5., L.6. (M.W.), L.7., L.8. (L.W.).

Parallel trimming of the oscillator grid circuit by T.C.3. (M.W.), and T.C.4., C.6. (L.W.).

Fixed padding by C.9. (M.W.) and C.7. (L.W.).

C.5. is the oscillator grid condenser, and the grid return R.4. is taken to the cathode.

In the anode circuit of the hexode section of V.1. is the primary L.3. of the 1st Intermediate Frequency transformer; the secondary L.4. is fed via R.5. to the control grid of V.2.

The primary and secondary are tuned by variable iron cores to a frequency of 465 kcs.

INTERMEDIATE FREQUENCY AMPLIFIER—V.2. MULLARD EF.39—

This valve, in conjunction with L.3., L.4. and L.9., L.10. operates as an amplifier at the Intermediate Frequency.

The control grid is fed from the A.V.C. line via decoupling R.7., C.10.

The screen is decoupled by R.6., C.11. and the anode by R.8., C.12.

Cathode bias by R.11., C.18. common to V.3. cathode.

The 2nd I.F. transformer L.9., L.10. forms the coupling to V.3.; tuning by variable iron cores.

SIGNAL RECTIFIER, A.V.C. RECTIFIER AND A.F. AMPLIFIER—V.3.—MULLARD EBC.33—

The signal rectifier anode is fed direct from the hot end of L.10; the signal voltage developed across V.R.1., the bottom end of which is taken to the cathode, is fed via C.16. and R.9. to triode control grid; R.10. is the grid return.

The A.V.C. rectifier anode is fed from a tap on L.9. via C.17.; a D.C. potential is developed across R.13. and fed back through decoupling circuits as negative bias to V.1. and V.2., giving automatic volume control. Delay voltage is obtained from the voltage drop across R.11.

Resistance capacity coupling R.12., C.20., R.14., and R.15. forms the coupling between V.3. and V.4.—I.F. by-pass and fixed tone correction by C.19.

OUTPUT STAGE—V.4. MULLARD CL.33—

Negative feedback is applied to the output valve; R.16. the cathode resistance, is used to apply the correct amount of feedback, carrying the D.C. component of the anode current and also the signal current, producing a voltage in opposition to the grid input.

The screen potential of V.4. is lower than that of the anode, as it is taken from the smoothed side of R.17. With a strong signal input, the voltage drop along the H.T. line is decreased as the A.V.C. produces an increase in negative bias to V.1. and V.2., thus reducing the total H.T. current taken by these valves, with the result that the screen potential of V.4. rises, enabling this valve to handle a larger output.

The output of this valve is fed through a special matching transformer to the Speaker speech coil. Additional tone correction by C.21.

H.T. RECTIFIER—V.5. MULLARD CY.31—

This is a half-wave rectifier used to supply the H.T. line; a peak surge resistor R.18. is connected in the anode circuit. R.F. by-pass by C.24.

Resistance filtering of the H.T. line by R.17. and C.22., reservoir C.23.

The heaters of all the valves and the scale lamp are wired in series with the ballast R.19. tapped for 200 to 250 volts supply mains.

Valve.	Electrode.	Pin No.	Mains Supply, 230v. A.C.		Mains Supply, 230v. D.C.	
			Voltage.	Current, mA.	Voltage.	Current, mA.
V.1. CCH.35. Frequency Changer.	Hex. Anode	3	105	1.1	90	0.9
	Screens.	4	50	1.7	48	1.4
	Osc. Anode.	6	50	1.9	48	1.6
	Cathode.	8	0.5	4.7	0.4	3.9
V.2. EF.39. I.F. Amplifier	Anode	3	75	2.7	65	2.3
	Screen	4	70	0.8	55	0.7
	Cathode	8	1.7	3.5	1.5	3.0
V.3. EBC.33. 2nd Rectifier, A.V.C. and A.F. Amplifier.	Anode	3	60	0.7	50	0.6
	Cathode	8	1.7	0.7	1.5	0.6
V.4. CL.33. Output Stage.	Anode	3	215	25	185	21
	Screen	4	105	1.8	90	1.5
	Cathode	8	4.0	26.8	3.4	22.5
V.5. CY.31. Mains Rectifier.	Anode	5	200 A.C.		200 D.C.	
	Cathode	8	230 D.C.	35.7	200 D.C.	30

When checking valve voltage and current readings, the receiver should be set to the lowest wavelength on the Medium waveband, the volume control to minimum—H.T. voltages as read on the 1,000v. scale, cathode voltages on the 10v. scale of the model 7 Universal Avometer, chassis being negative.

DISMANTLING.

REMOVING CHASSIS FROM CABINET—

Remove the tuning knob. Lay receiver on its side and remove wavechange and volume control knobs by inserting screwdriver through holes in the bottom of the cabinet to loosen grub-screws. With the receiver upright, release the frame aerial by removing the nut and bolt located about $\frac{1}{2}$ in. away from the hole provided for the tuning knob. Take out the two bolts, which pass through the securing lugs at the extreme bottom corners of the chassis. Carefully withdraw the chassis and frame aerial from the cabinet.

NOTE—When replacing the chassis ensure that the locating pins projecting from the front of the chassis are correctly positioned in the recessed cups in the cabinet. The tuning scale can be taken out by unscrewing the two bolts holding the retaining clips at the top edge of the scale, and lifting it out of the slot in the cabinet. Note that rubber channels are fitted to the top and bottom edges of the glass scale and there is a left and a right-hand retaining clip.

REMOVING SPEAKER FROM CHASSIS—

The speaker is removed from the chassis by taking out the bolts holding it to the pulley mounting plate and brackets. Where a Celestion speaker is fitted the output transformer is attached by bolts which screw into threaded clips on the speaker frame. Ordinary nut and bolt fixing is employed where the speaker is a Rola model.

Front view of D.A.C.90 Chassis showing Tuning Drive and Calibration Points on the Pulley Mounting Plate →

CIRCUIT ALIGNMENT.

The use of a reputable modulated Signal Generator, with a variable output, is essential for the accurate alignment of the R.F. and I.F. circuits.

WARNING—When aligning an A.C./D.C. mains receiver, the Signal Generator should always be isolated from the chassis by a fixed capacitor.

INTERMEDIATE FREQUENCY CIRCUITS—465 Kcs.

Switch to the Medium Waveband and turn the tuning condenser to maximum capacity. Connect the Signal Generator, via a fixed capacitor, to the Control grid (top cap) of V.2. and chassis.

Feed in a 465 kcs. signal. Turn volume control to maximum. ADJUST CORES of L.9. and L.10. for maximum output. Transfer the Signal Generator to the Control grid (top cap) of V.1. ADJUST CORES of L.3. and L.4. for maximum output. Re-adjust all cores with Signal Generator still connected to grid of V.1.

RADIO FREQUENCY CIRCUITS—

Check the position of the tuning pointer in relation to the gang condensers. With the vanes fully meshed, the centre of the pointer should coincide with points D and E shown in the adjacent illustration. The points DE, CF show the horizontal limits of traverse of the pointer.

Connecting the Signal Generator to the Control grid of the Frequency changer to align the R.F. circuits would heavily damp the frame aerial. The procedure is to feed the output of the Signal Generator into a single turn loop of wire approximately the size of the Frame Aerial (5¾ ins.), which is placed 6 ins. to 12 ins. (according to the output of the Signal Generator) away from and parallel to the Frame Aerial.

NOTE—Unless the chassis has been taken out for the purpose of replacing components, etc., the Oscillator circuits can be aligned without removing the receiver from the cabinet; holes are provided in the bottom of the latter for the adjustment of T.C.3. and T.C.4.

MEDIUM WAVEBAND—

With the Signal Generator set up as described above, and set to 300 m. (1,000 kcs.) switch the receiver to the Medium Waveband and tune to 300 m. (1,000 kcs.). If the receiver has been removed from the cabinet, 300 m. (1,000 kcs.) is represented by point K on the pulley mounting plate, and the tuning condenser should be rotated until the pointer coincides with this point. ADJUST T.C.3., Oscillator, and T.C.1., Aerial, for maximum output. Tracking points are 200 m. (1,500 kcs.) and 500 m. (600 kcs.) represented by points L and J respectively, on the pulley mounting plate.

LONG WAVEBAND—

Tune the Signal Generator to 1,500 m. (200 kcs.). Switch the receiver to Long Waveband and set the pointer to coincide with point H—1,500 m. (200 kcs.)—on the pulley mounting plate. ADJUST T.C.4. Oscillator and T.C.2. Aerial, for maximum output. Tracking points are 1,000 m. (300 kcs.) and 2,000 m. (150 kcs.) shown by points G and I respectively.

NOTE—As the aerial trimmer T.C.1. is common to both Medium and Long Wavebands, always align the Medium Waveband first.

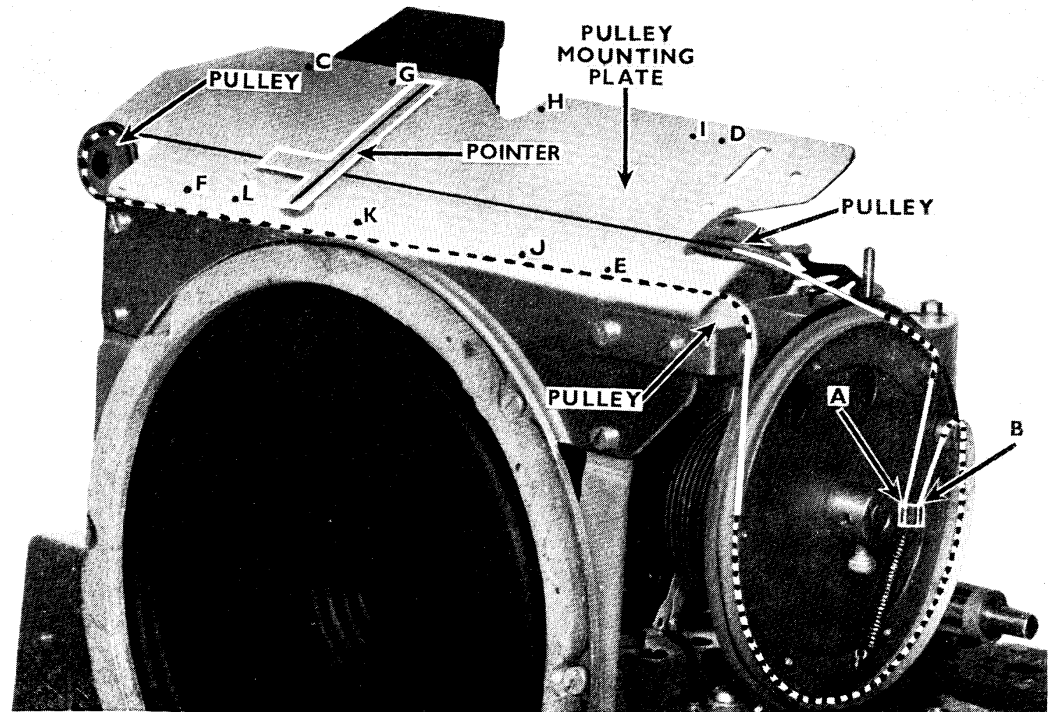

FITTING WIRE DRIVE.

PART NUMBERS—

Pulley mounting plate	S.12713.	Pointer	S.12714.
Tuning Scale	S.12730.	Lampholder and bracket	S.12722.*
Wire and Anchor	S.12717.	Scale	S.12730.
		Variable Condenser and Drive	S.12716.

NOTE—As Part Number S.12716 includes the complete Variable Condenser, friction drive and mounting brackets, please state, when ordering, whether it is only the Drive Assembly required.

The wire drive consists of a flexible steel wire 32 ins. long, and the length between points A and B (shown on the illustration) after clenching in the anchor should be 30¾ ins.

When a new flexible steel wire is fitted, it is advisable to remove the screw holding the bracket (where fitted) supporting the scale frame, in order to slip the new wire under the scale frame plate.

The illustration shows clearly the position of the wire drive, and when it is correctly positioned, the drive wheel should be turned to set the variable condenser to maximum capacity; then the centre line of the pointer should coincide with the top end of the waveband line. Points D and E on the Pulley mounting plate shown in the above illustration. The pointer is detachable, and may be placed in position on the steel wire by gently easing over two small clips on the back.

* A modified form of lampholder and bracket is fitted to receiver above serial number 10/01000. The part number is S.12984.

SERVICE NOTES.

Before trying to locate a fault in the Receiver, it is important to see that all the valves are up to standard, and making good contact in their holders.

Voltage readings should be checked on all valves; speaker and output transformer windings checked for continuity.

Check the Mains Rectifier circuit, R.18., R.19., and H.T. line R.17.

If the above components and voltages are found to be correct, apply an A.F. signal to the control grid of V.3. to check the sensitivity of V.3. and V.5.; if there is no output, or it is very small, a component between the anode of V.3. and the output stage would appear to be at fault.

To check the R.F. side of the receiver, first commence with the I.F. stage V.2. inject a 465 kc. into the control grid of V.2. (top cap) and if possible check the output against another receiver of the same type; this procedure will check the operation of V.2. and the 2nd I.F. transformer.

To check the 1st I.F. transformer, feed in the 465 kc. signal to the hexode anode of V.1. (pin 3).

Should these tests prove the sensitivity to be approximately correct, it should be possible to trace the fault to the aerial or oscillator circuits.

The oscillator circuits can be checked by connecting a signal generator to the hexode control grid of

V.1. (top cap) and inserting an R.F. signal within the limits covered by each waveband.

If these circuits are oscillating, transfer the output from the generator into a single turn loop, coupled to the frame aerial, and feed in a similar signal to that used for the oscillator circuits on each waveband.

It is essential that the source of supply from the mains should be checked first, and then work back from V.5. to V.1.

COMPONENTS AFFECTING CALIBRATION—

Medium Waveband—L.5., T.C.3., C.9.

Long Waveband—L.7., T.C.4., C.6., C.7.

Scale reading—Check pointer position in relation to the tuning scale, see paragraph entitled "Fitting Wire Drive" on page 7.

Intermediate frequency circuits tuned to incorrect frequency—Re-align on 465 kcs. according to instructions on page 7.

A.V.C. COMPONENTS—

V.3., R.1., R.7., R.13., C.1., C.10.

A.V.C. is applied to V.1. and V.3.

The cathode resistor of V.3. produces delayed A.V.C. voltage; therefore, if R.1. and C.18. are faulty, distortion will result.

LIST OF PART NUMBERS.

These are component Part Numbers not previously shown against the items in the Service Manual.

When ordering replacement or spare parts, please quote:—

- Type and serial number of receiver.
- Part number and description of item.
- Quantity required.

Baffle	P.12496
Cabinet	P.12400
Cabinet back	P.12495
Cowl assembly (complete with R.19. and mains tapping)	S.12715
Grid cap (I.F. control grid)	S.9389E
Grid cap (D.D.T. control grid)	S.9389A
Knob (Tuning)	P.12405

Knob (Volume Control)	P.12406
Knob (Wavechange)	P.12410
Mains lead with connectors	S.12741
Pulley (Drive)	P.12416
Rubber channels for scale	P.12431
Switch S.1. and S.2. wafer only	P.2986
Scale lame	P.3794

Valves:—

Mullard CCH.35	P.3795
" EF.39	P.3796
" EBC.33	P.3797
" CL.33	P.3798
" CY.31	P.3799
Valve holder V.1. to V.5.	P.3900
Window (scale)	P.12752

MODIFICATION : MODEL DAC.90

Circuit Diagram, page 2. V1 cathode should be pin No. 8

An alternative part number for C22/23 is AS16476.

Coil and Frame Aerial Connections, page 4. On later models the wiring of the coil deck has been modified and the coil connections are now as follows:—

Medium Waveband Oscillator L5, L6.

Tag No. 1. L6—To L8 tag 3.

Tag No. 2. L5—To S2 tag M, TC3 fixed plates.

Tag No. 3. L6—To V1 pin 6.

Tag No. 4. L5—C9 connected, TC3 moving plates.

Long Waveband Oscillator L7, L8.

Tag No. 1. L8—To V1 pin 4.

Tag No. 2. L7.—To S2 tag N, C6, TC4 fixed plates connected.

Tag No. 3. L8—To L6 tag 1.

Tag No. 4. L7.—C6 and C7, TC4 moving plates, S2 tag P connected.

isk, London

ERRATUM : MODEL DAC.90

Circuit Diagram page 2. Link between tag No. 3 L.W. frame aerial and the junction of R1 and C1 should be omitted.

BUSH RADIO

Service Instructions

A.C. MAINS

MODEL A.C.90

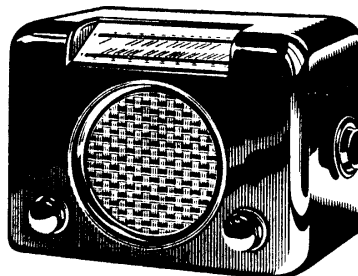

Front View of A.C. 90 Receiver.

THIS REFERENCE SHEET SHOULD BE USED IN CONJUNCTION WITH THE D.A.C.90 SERVICE INSTRUCTIONS

SPECIFICATION.

BASIC CIRCUIT—

The A.C.90 circuit is similar to the D.A.C.90 but it uses a mains auto-transformer to supply the valve heaters and scale lamp which are all connected in series. The H.T. supply to the half-wave rectifier is taken from the 210v. tap on the auto-transformer.

VALVES—

Mullard CCH.35	Heater	7.0v.	0.2A
„ EF.39		6.3v.	0.2A
„ EBC.33		6.3v.	0.2A
„ CL.33		33.0v.	0.2A
„ CY.31		20.0v.	0.2A

All valves are fitted with International octal bases.

SCALE LAMP—

Type 3.5v. 0.3A. A lamp of this rating only should be used for replacement.

VOLTAGE RANGE—

A.C. mains only, 100–120 volts, or 200–250 volts, 40/100 cycles.

MAINS CONSUMPTION—

Approximately 32 watts.

VALVE VOLTAGES—

With 230v. A.C. input the valve voltages may differ slightly from those shown in the D.A.C.90 Service Manual.

PART NUMBERS—

Mains auto-transformer: Part No. S12708.

CONNECTIONS TO MAINS AUTO-TRANSFORMER

Tag "E" to chassis.
Tag "D.L." to V.3 pin 2.
Tag "H" to V.5 pin 2.
210v. Tapping to R.18.

For all other information refer to D.A.C. 90 Service Manual

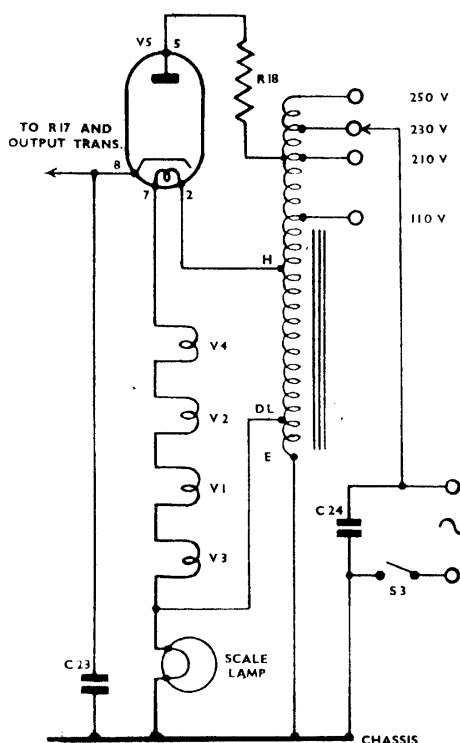

Mains Input Circuit of A.C.90 Receiver