

Schematic diagram

X<sub>1</sub> 2SA122

X<sub>2</sub> 2SC76

X<sub>3</sub> 2SC76

X<sub>4</sub> 2SD65

X<sub>5</sub> 2SD66

X<sub>6,7</sub> 2SB52X2

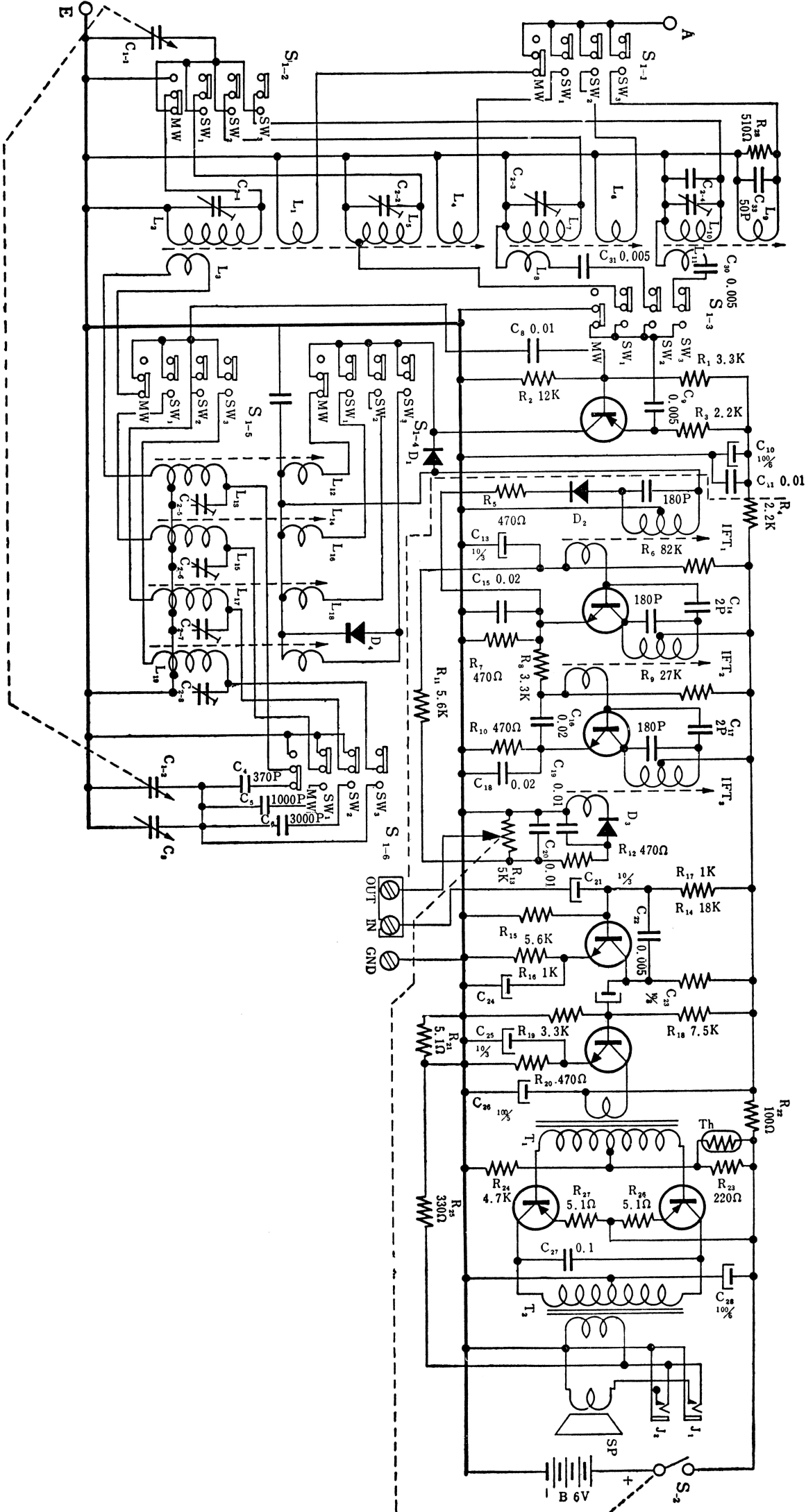

### Mounting diagram for coil pack (printed side)

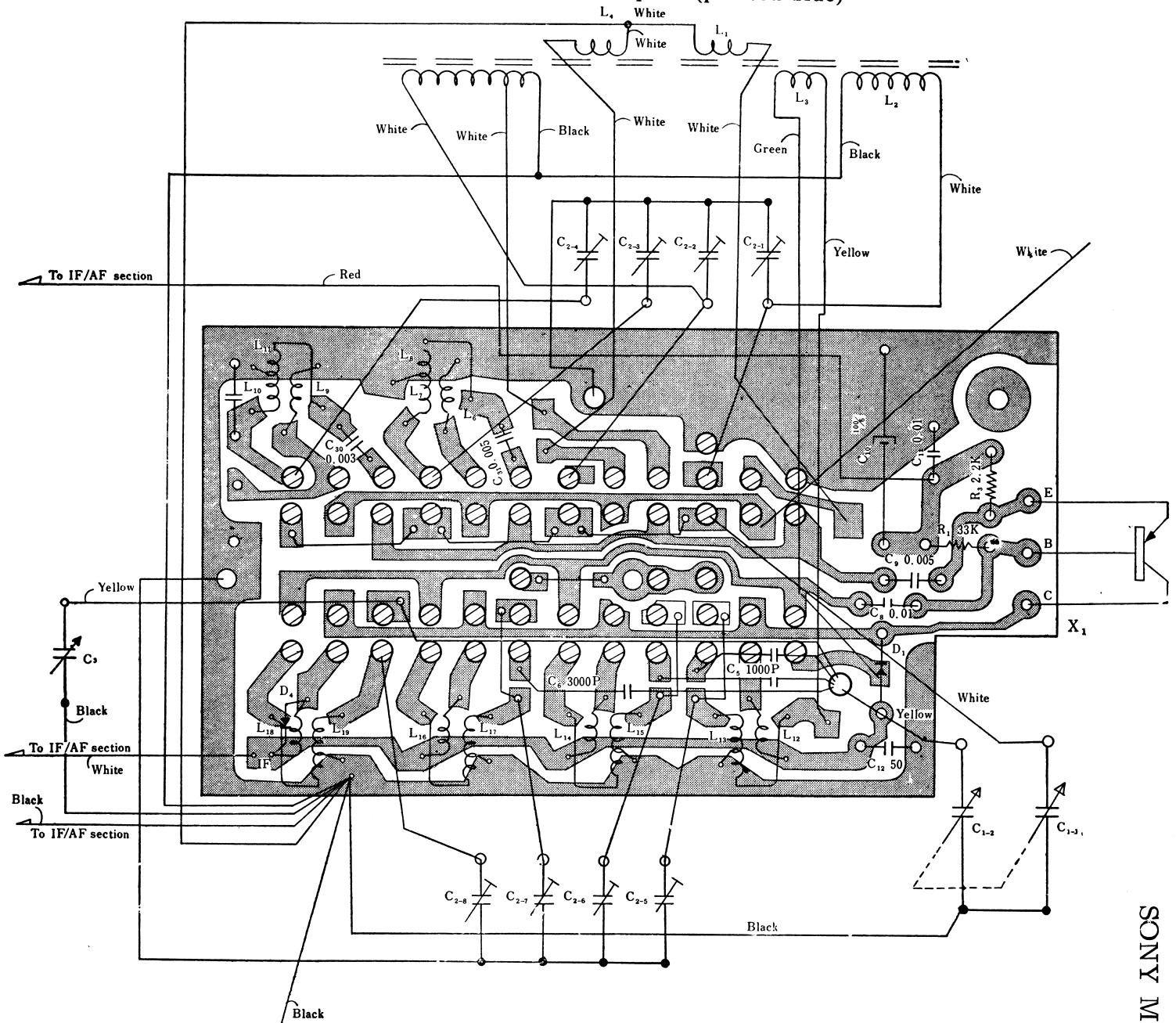

### Mounting of IF/AF section

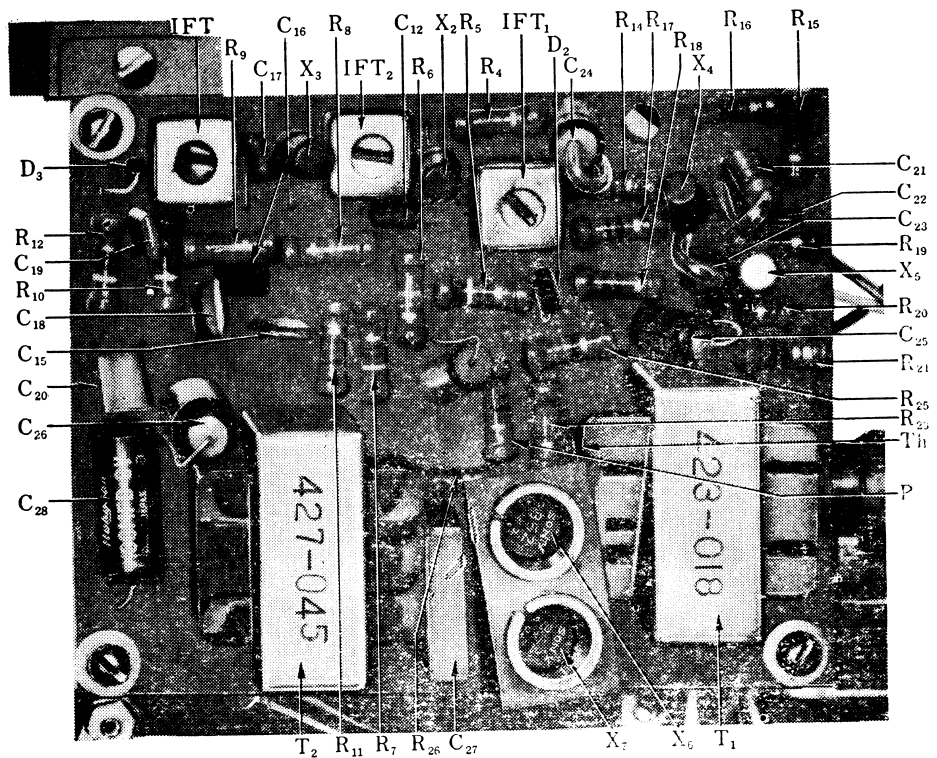

Mounting diagram for IF/AF section (printed side)

