

COMMUNICATIONS RECEIVER
TYPE RA.17L

Operating and Maintenance Instructions

Technical Handbooks Department

©RACAL ELECTRONICS LIMITED
Western Road,
Bracknell, Berkshire
England.

OM45-5-63-1450
ISSUE 2

PRINTED IN ENGLAND

LIST OF CONTENTS

Front view of Receiver Type RA.17

PART 1

TECHNICAL DETAILS AND OPERATION

- SECTION 1 Introduction
- SECTION 2 Installation
- SECTION 3 Operation
- SECTION 4 Brief Technical Description
- SECTION 5 Detailed Circuit Description

PART 2

MAINTENANCE

- SECTION 1 Spurious Responses
- SECTION 2 Valve Data
- SECTION 3 Fault Location
- SECTION 4 Representative Test Data
- SECTION 5 Alignment Procedures
- SECTION 6 Dismantling and Replacement Procedures
- SECTION 7 Illustrations
- SECTION 8 List of Circuit Components



THE RACAL COMMUNICATIONS RECEIVER
TYPE R.A.17

PART 1
TECHNICAL DETAILS
AND
OPERATION

PART 1

TECHNICAL DETAILS AND OPERATION

INDEX

	<i>Page</i>	
SECTION 1	INTRODUCTION	9
1.1	General Description	9
1.2	North American Version	9
1.3	Constructional Details	9
1.4	Technical Specification	9
SECTION 2	INSTALLATION :—	
2.1	Supply	11
2.2	Fuses	11
2.3	Aerial	11
2.4	Audio Outputs	11
2.5	100 KC/S I.F. Output	11
2.6	Automatic Volume Control	11
SECTION 3	OPERATION :—	
3.1	Function of Controls	13
3.2	Preliminary Setting-Up	14
3.3	Film Scale Calibration	14
3.4	B.F.O. Calibration	14
3.5	Tuning	14
3.6	" S " Meter	14
SECTION 4	BRIEF TECHNICAL DESCRIPTION :—	
4.1	Signal Input	15
4.2	First Mixer	15
4.3	Harmonic Generator and Mixer	15
4.4	Second Mixer	15
4.5	Third Mixer	15
4.6	Third I.F. Stage	15
4.7	A.F. Stages	15
4.8	Crystal Calibrator	15
SECTION 5	DETAILED CIRCUIT DESCRIPTION :—	
5.1	Aerial Circuit	19
5.2	R.F. Amplifier	19
5.3	30 Mc/s Low-Pass Filter	19
5.4	First Variable Frequency Oscillator	19
5.5	First Mixer	19
5.6	40 Mc/s Band-Pass Filter	19
5.7	1 Mc/s Crystal Oscillator	19
5.8	Harmonic Generator	20
5.9	32 Mc/s Low-Pass Filter	20
5.10	Harmonic Mixer	20
5.11	2-Stage 37.5 Mc/s Amplifier (1)	20
5.12	37.5 Mc/s Band-Pass Filter	20
5.13	37.5 Mc/s Amplifier (2)	20
5.14	Second Mixer	21
5.15	2-3 Mc/s Tuned Band-Pass Filter	21
5.16	Third Mixer	21
5.17	Second Variable Frequency Oscillator	21
5.18	Crystal Filter	21
5.19	100 kc/s L-C Filter	21
5.20	First 100 kc/s I.F. Amplifier	22
5.21	Second 100 kc/s I.F. Amplifier	22
5.22	Diode Detector	22
5.23	Noise Limiter	22
5.24	A.V.C. and T.C. Diode	23
5.25	Audio Output	23
5.26	A.F. Line Output	23
5.27	Beat Frequency Oscillator	23
5.28	100 kc/s I.F. Output	23
5.29	Crystal Calibrator	24
5.30	Power Supplies	24
5.31	System Switch	24
5.32	" S " Meter	24

SECTION 1

INTRODUCTION

1.1 GENERAL DESCRIPTION

The Communications Receiver Type RA.17 has been designed for use as a general purpose receiver which will provide a high order of sensitivity, selectivity and stability. The receiver covers a frequency range from 1.0 to 30.0 Mc/s and extending, with slightly degraded performance, down to 500 kc/s.

A built-in crystal-controlled calibrator provides reference signals at each 100 kc/s division to permit exact alignment of the scale pointer. Two independent i.f. outputs, in parallel, at 100 kc/s are provided for external use if required. A number of audio outputs are available providing flexibility during operation; a small loudspeaker is fitted for monitoring purposes.

The receiver is designed to operate from 100–125 volts and 200–250 volts, 45–65 c/s mains supply. The power consumption is approximately 100 watts.

1.2 NORTH AMERICAN VERSION

North American versions of the RA.17 receiver are identical to the Standard model but include minor variations in detail to comply with North American practice. Certain tubes are changed to ensure that the set employs types commercially available in North America; this entails slight circuit changes to allow for differences in the tube operating voltages. The level meter circuits are modified to include a calibrated "S" meter range. The a.f. output stage is modified to give a maximum output of 1 watt. Coaxial connections are changed from British to North American standards and the supply connection comprises a lead directly connected to the set in place of the fixed plug and free socket fitted to the British version.

These instructions cover both types of receiver. Where applicable, attention is drawn to the differences between the two versions.

1.3 CONSTRUCTIONAL DETAILS

The receiver is designed for both bench (table) and rack mounting. The front panel is painted Light Battleship Grey (British Standard Specification 381C, colour 697) and has been carefully designed to minimise operator fatigue.

The dimensions of the $\frac{1}{4}$ -in. thick front panel conform with the requirements for mounting in a standard 19-in. rack.

For bench mounting, the receiver is fitted in a robust steel cabinet which has a rear opening to enable the operator to gain easy access to the power input socket (Standard version only), the fuses and the termination strips.

A dust cover is provided with both models. This may be removed from cabinet-mounted receivers in conditions of high ambient temperature.

The chassis and major modules are of cast construction thus ensuring maximum rigidity and effective electrical screening.

Each receiver is supplied with three keys to facilitate removal of the control knobs, a plastic trimming tool and free coaxial terminations for aerial and i.f. connections. Extra sleeves are provided with the terminations for alternative coaxial cable sizes.

1.4 TECHNICAL SPECIFICATION

Frequency Range	1–30 Mc/s. Range extends to 0.5 Mc/s with slight degradation of performance.
Stability	The average receiver, after warm-up time of 1 to 2 hours, will remain tuned to within 50 c/s of the selected frequency under conditions of constant supply voltage and ambient temperature.
Input Impedance	75 Ω unbalanced.
Tuning	Effective scale length of approximately 145 feet, i.e. about 6 inches of scale length corresponds to 100 kc/s. Frequency increments remain substantially constant over the entire range.
Calibration	A 100 kc/s signal derived from a 1 Mc/s crystal oscillator having an accuracy of 5 parts in 10 ⁶ provides check points at 100 kc/s intervals.
Sensitivity	A1 reception, bandwidth 3 kc/s: 1 μ V for 18dB signal-to-noise ratio. A2 reception, 30% modulated, bandwidth 3 kc/s: 3 μ V for 18dB signal-to-noise ratio.
Intermodulation	More than 100dB down for interfering signals at least 10% removed from the wanted signal.

Cross Modulation	For wanted signal levels between 3 μ V and 1mV, an interfering signal 10 kc/s removed and modulated 30% must have a level greater than 50dB above that of the wanted signal to produce a cross modulation of 3%. The ratio of wanted to unwanted signal is improved, up to 10% off tune, at the rate of 3dB per cent.																																
Blocking	With similar conditions to those for cross modulation, an unwanted signal f2 must be 60dB greater before the audio output of the wanted signal f1 is reduced by 3dB due to blocking.																																
Selectivity	Six alternative i.f. bandwidths are obtained by means of a selector switch. Filter details are: <table border="0" style="margin-left: 40px;"> <tr> <td></td> <td style="text-align: center;">-6dB</td> <td></td> <td style="text-align: center;">-66dB</td> </tr> <tr> <td></td> <td></td> <td style="text-align: center;">100 kc/s I.F. Output</td> <td style="text-align: center;">Detected Output</td> </tr> <tr> <td>1.</td> <td>13 kc/s</td> <td>35 kc/s</td> <td>28 kc/s</td> </tr> <tr> <td>2.</td> <td>6.5 kc/s</td> <td>22 kc/s</td> <td>20 kc/s</td> </tr> <tr> <td>3.</td> <td>3.0 kc/s</td> <td>15 kc/s</td> <td>15 kc/s</td> </tr> <tr> <td>4.</td> <td>1.2 kc/s</td> <td>8 kc/s</td> <td>8 kc/s</td> </tr> <tr> <td>5.</td> <td>0.3 kc/s</td> <td>Less than 2 kc/s</td> <td>Less than 2 kc/s</td> </tr> <tr> <td>6.</td> <td>0.10 kc/s</td> <td>Less than 1.5 kc/s</td> <td>Less than 1.5 kc/s</td> </tr> </table>		-6dB		-66dB			100 kc/s I.F. Output	Detected Output	1.	13 kc/s	35 kc/s	28 kc/s	2.	6.5 kc/s	22 kc/s	20 kc/s	3.	3.0 kc/s	15 kc/s	15 kc/s	4.	1.2 kc/s	8 kc/s	8 kc/s	5.	0.3 kc/s	Less than 2 kc/s	Less than 2 kc/s	6.	0.10 kc/s	Less than 1.5 kc/s	Less than 1.5 kc/s
	-6dB		-66dB																														
		100 kc/s I.F. Output	Detected Output																														
1.	13 kc/s	35 kc/s	28 kc/s																														
2.	6.5 kc/s	22 kc/s	20 kc/s																														
3.	3.0 kc/s	15 kc/s	15 kc/s																														
4.	1.2 kc/s	8 kc/s	8 kc/s																														
5.	0.3 kc/s	Less than 2 kc/s	Less than 2 kc/s																														
6.	0.10 kc/s	Less than 1.5 kc/s	Less than 1.5 kc/s																														
I.F. Output	Bandwidths 5 and 6 are obtained with crystal-lattice filters; differences in centre frequencies of these bandwidth settings do not exceed 50 c/s. 100 kc/s at 75 Ω impedance. Level 0.2V approx. with a.v.c. in operation. Two outlets in parallel are provided.																																
Image and Spurious Responses	With wideband or tuned input, external image signals are at least 60dB down. Internally generated spurious responses are below noise level in all cases.																																
Noise Factor	Better than 7dB throughout entire range.																																
B.F.O. Range	± 8 kc/s.																																
B.F.O. Stability	With constant ambient temperature and supply voltage, drift after warm-up time of 1 to 2 hours does not exceed 50 c/s. For input level variations from 10 μ V to 1mV, b.f.o. drift is negligible.																																
Automatic Volume Control	A.V.C. is applied to the r.f. and the final i.f. stages. An increase in signal level of 20dB above 1 μ V improves the signal-to-noise ratio by 18dB. An increase in signal level of 100dB above 1 μ V increases the a.f. output by less than 7dB.																																
A.V.C. Time Constants	Short: Charge—25 milliseconds. Discharge—200 milliseconds. Long: Charge—200 milliseconds. Discharge—1 second.																																
A.F. Response	With 13 kc/s bandwidth, response remains within ± 4 dB from 250 c/s to 6000 c/s.																																
A.F. Output	1. 2 $\frac{1}{2}$ -in. loudspeaker (50mW) (1W, North American version) on front panel (switched). 2. Two headphone sockets in parallel on front panel. (See Note). 3. Three independent outputs of 3mW at 600 Ω at rear of chassis. 4. One output of 10mW at 600 Ω . Preset level is independent of A.F. GAIN control setting. 5. One output of 50mW (1W, North American version) at 3 Ω . <i>Note:</i> The two headphone sockets are connected across the loudspeaker on the British version and across one of the 600 Ω , 3mW outlets on the North American version of the receiver.																																
Distortion	Not greater than 5% at 50mW output. (1W, North American version)																																
Hum Level	With A.F. GAIN control at maximum, the hum level is never worse than 40dB below rated output (50mW or 1W respectively).																																
Noise Limiter	A series noise limiter circuit can be switched into operation to provide limiting at modulation levels exceeding 30%.																																
Meter Indication	Alternative switching for indication of signal carrier level or a.f. output level. An 'S' meter is incorporated in the North American version of the receiver.																																
Power Supply	100-125V and 200-250V, 45-65 c/s. Power consumption 100W approx.																																
Dimensions	<table border="0" style="margin-left: 40px;"> <tr> <td></td> <td style="text-align: center;">Height</td> <td style="text-align: center;">Width</td> <td style="text-align: center;">Depth</td> </tr> <tr> <td>For rack mounting</td> <td style="text-align: center;">10$\frac{1}{2}$</td> <td style="text-align: center;">19</td> <td style="text-align: center;">20$\frac{1}{2}$ in.</td> </tr> <tr> <td>(fitted dust cover)</td> <td style="text-align: center;">26.7</td> <td style="text-align: center;">48.25</td> <td style="text-align: center;">51 cm.</td> </tr> <tr> <td>Fitted cabinet</td> <td style="text-align: center;">12</td> <td style="text-align: center;">20$\frac{1}{2}$</td> <td style="text-align: center;">21$\frac{1}{2}$ in.</td> </tr> <tr> <td></td> <td style="text-align: center;">30.5</td> <td style="text-align: center;">52</td> <td style="text-align: center;">55.6 cm.</td> </tr> </table>		Height	Width	Depth	For rack mounting	10 $\frac{1}{2}$	19	20 $\frac{1}{2}$ in.	(fitted dust cover)	26.7	48.25	51 cm.	Fitted cabinet	12	20 $\frac{1}{2}$	21 $\frac{1}{2}$ in.		30.5	52	55.6 cm.												
	Height	Width	Depth																														
For rack mounting	10 $\frac{1}{2}$	19	20 $\frac{1}{2}$ in.																														
(fitted dust cover)	26.7	48.25	51 cm.																														
Fitted cabinet	12	20 $\frac{1}{2}$	21 $\frac{1}{2}$ in.																														
	30.5	52	55.6 cm.																														
Weight																																	
Rack mounted	67 lb. (30.5 kg).																																
In cabinet	97 lb. (44 kg.)																																

SECTION 2

INSTALLATION

After carefully unpacking the receiver, remove the dust cover and make sure that all valves and screening cans are firmly in place and that no packing material remains within the tuning mechanism.

2.1 SUPPLY

Ascertain that the main transformer is set to the appropriate voltage tapping. This is carried out by means of the plug-in links in Standard models and by soldered connections to the transformer in the North American versions. Connect a 3-core power lead (not provided) to the free 3-pin socket supplied and attach this to the input power plug (PL10). On North American versions, a power cable is permanently fitted. Check that the terminals HT.1 and HT.2 situated on the main chassis are linked (unless the L.F. Converter is in use). Note that a form of receiver muting can be obtained by opening this link when the associated transmitter is keyed.

Connect the power lead to the mains supply.

2.2 FUSES

Ensure that the rating of the supply fuse and the h.t. fuse is correct viz:

Supply fuse 2A.

H.T. fuse 350mA (North American version 250mA, anti surge).

2.3 AERIAL

The impedance at the aerial (antenna) input plug is designed to match into a 75Ω unbalanced transmission line. The cable termination supplied with the receiver is provided with alternative sleeves to enable it to be used with a type UR.18 or UR.70 cable or similar cables of nominal $\frac{1}{2}$ -in. or $\frac{3}{4}$ -in. respectively.

2.4 AUDIO OUTPUTS

(a) The two headphone sockets situated on the front panel are connected across the 3Ω speaker.

Note: On the North American receiver, the headphone sockets are connected across one of the 600Ω 3mW outlets.

(b) The following outputs are connected to the terminal strip situated on the rear of the receiver :—

(i) Three 600Ω outlets at 3mW.

(ii) One 3Ω outlet at 50mW (1W, North American version).

(iii) One 600Ω outlet at 10mW. This output is controlled by a pre-set A.F. LEVEL control on the front panel and is independent of the outputs previously described.

2.5 100 KC/S I.F. OUTPUT

The connection consists of two coaxial plugs connected in parallel to the 100 kc/s output. The total load should not be less than 70Ω (e.g. with one outlet loaded by 75Ω , the other can be used as a high impedance source).

2.6 AUTOMATIC VOLUME CONTROL

The a.v.c. line is brought out to the terminal strip on the rear of the chassis for such applications as diversity reception.

SECTION 3

OPERATION

References to the controls are in capitals and are in accordance with the panel titles adjacent to them. Control names on the North American versions are shown in brackets when they differ from the standard titles.

It should be noted that the method of operation of the receiver, which is extremely simple, depends largely upon the purpose for which the receiver is being employed. The instructions given below are concerned with tuning the receiver to a signal of known frequency; also, notes are included on the use of the various controls.

3.1 FUNCTION OF CONTROLS

- MAINS (POWER)** Makes and breaks the power supply to the mains transformer.
- AE. (ANT.) RANGE MC/S** This control enables the selection of any one of six aerial ranges plus WIDEBAND position.
- AE. (ANT.) ATTENUATOR** This control enables the operator to reduce the level of all incoming signals when strong unwanted signals are present which cannot be rejected sufficiently by tuning the aerial; the input level can also be reduced if the required signal is causing overloading in the early stages of the receiver.
- MEGACYCLES** This scale should be checked periodically to ensure that its setting is reasonably central with respect to the band in use. This is indicated by a reduction of signal or noise on either side of the correct setting.
- SYSTEM** This switch provides facilities for STANDBY, MANUAL, A.V.C., CALIBRATION and CHECK B.F.O.
- BANDWIDTH** The two crystal filters determining the bandwidth are adjusted to ensure that their centre frequencies are all within 50 c/s, thus any bandwidth can be selected without retuning the receiver. Six bandwidths are provided as follows:
13 kc/s, 6.5 kc/s, 3 kc/s and 1.2 kc/s (L-C); 300 c/s and 100 c/s (crystal).
- A.F. GAIN** The A.F. Gain control adjusts the audio output.
- KILOCYCLES** The calibration of this scale may be checked at 100 kc/s intervals by setting the system switch to the CAL position.
- B.F.O.** The B.F.O. ON/OFF switch makes or breaks h.t. to the beat frequency oscillator.
- B.F.O. NOTE KC/S** The b.f.o. is exactly tuned to a central point on the i.f. amplifier response when the B.F.O. NOTE KC/S control is set to zero-beat with the calibrator. Having standardized the b.f.o. frequency, the frequency of an incoming signal may be accurately measured by setting the KILOCYCLES control to a zero-beat position; the b.f.o. should be detuned in order to produce an acceptable note for c.w. reception.
- AE. (ANT.) TUNE** If maximum sensitivity is not required, the aerial need not be tuned unless strong unwanted signals are present. It should be noted that the presence of very strong signals anywhere within the spectrum may cause cross-modulation unless the aerial is tuned. Under these conditions, CARE MUST BE TAKEN TO AVOID TUNING THE INPUT TO THE INTERFERING SIGNALS instead of the signal required. Familiarity with the tuning controls will facilitate this.
- I.F. GAIN** The I.F. GAIN control is operative both in the MAN. and the A.V.C. positions of the System switch. In the MAN. position of the System switch, the setting of the control should always be at a minimum consistent with satisfactory a.f. level. The following should be noted when the System switch is in the A.V.C. position. Reducing the i.f. gain results in a reduction of a.v.c. loop gain together with a degraded a.v.c. characteristic. Therefore when in the A.V.C. position, it is desirable that the I.F. GAIN control be set to maximum. A possible exception of this occurs when receiving interrupted signals in which the carrier is periodically switched off; in this case, receiver noise could be troublesome during the quiet intervals.
- A.V.C.** The choice of time-constant depends largely on conditions. The LONG time-constant (1 second) should be employed with voice signals; the SHORT time-constant may be used with high speed telegraphy or voice. For hand (low) speed telegraphy, the MAN. position of the System switch should be used (refer to I.F. GAIN).

A.F. LEVEL

The preset control sets the a.f. level in a separate a.f. stage for feeding a 600Ω 10mW line. It is unaffected by the position of the main A.F. GAIN control. IT IS MOST IMPORTANT that the A.F. LEVEL is not turned towards its maximum position unless the 10mW 600Ω winding is suitably terminated.

LIMITER

When switched into use, the LIMITER reduces the effects of noise peaks exceeding the level of a 30% modulated signal. It does not introduce noticeable distortion below a 30% modulation level.

METER

With the METER switch in the R.F. LEVEL position, the meter indicates the signal diode current. In the A.F. LEVEL position, the 10mW 600Ω output only is monitored. A calibration mark is provided at 10mW.

SPEAKER

The loudspeaker may be switched ON or OFF as required. The two telephone jack sockets remain in circuit in either position of the SPEAKER switch.

3.2 PRELIMINARY SETTING-UP

Switch on the supply by means of the MAINS (POWER) switch. Allow a few minutes for the receiver to warm up.

Set the AE. (ANT.) RANGE MC/S switch to WIDEBAND. Switch the AE. (ANT.) ATTENUATOR to MIN. Set the A.F. GAIN control to its mid-position. Turn the System switch to MAN. Switch the LIMITER and B.F.O. off.

Select a BANDWIDTH of 3 or 6.5 KC/S. Rotate the I.F. GAIN control to three-quarters of fully clockwise.

3.3 FILM SCALE CALIBRATION

Set the System switch to CAL. Select a BANDWIDTH of 3 KC/S.

Set the KILOCYCLES scale to that 100 kc/s point which is nearest to the frequency required and adjust the control accurately until a zero-beat note is obtained. Move the milled cursor slide on the dial escutcheon so that the pointer coincides exactly with the selected 100 kc/s division.

Restore all other controls to the preliminary setting shown in Section 3.2 above.

3.4 B.F.O. CALIBRATION

Switch on the b.f.o. and set the System switch to CHECK B.F.O.

Adjust the B.F.O. NOTE KC/S control to zero-beat.

Restore all other controls to the preliminary setting shown in Section 3.2 above.

3.5 TUNING

Set the MEGACYCLES dial to the required integer. The tuning of this control is quite flat and the optimum position may be found by adjusting the control to the point at which the receiver noise is greatest.

Set the KILOCYCLES scale to the required frequency.

Set the AE. (ANT.) RANGE MC/S switch to the correct frequency band. Adjust the AE. (ANT.) TUNE control for maximum noise.

It should now be possible to identify the desired signal. Switch on the b.f.o. if the required signal is not modulated.

Switch on the b.f.o. and set the calibrated B.F.O. NOTE KC/S control to the zero position, then adjust finally for a zero-beat note.

If it is desired to operate the receiver on c.w., adjust the B.F.O. NOTE KC/S control to the most acceptable audio-beat note. Set the BANDWIDTH control for optimum reception. Set the A.F. GAIN to MAX. (consistent with no over-loading) and adjust the output level with the I.F. GAIN control.

For m.c.w. or r.t. reception, switch the b.f.o. off. Adjust the I.F. and A.F. GAIN controls as for c.w. reception. (Refer to 3.1, I.F. GAIN.)

Set the System switch to A.V.C. and select a SHORT or LONG time-constant as required.

Set the BANDWIDTH control to the optimum position.

3.6 "S" METER

The "S" meter in North American versions should be correctly set to zero in order to obtain the maximum accuracy of calibration.

With no antenna connected, set the ANT. ATTENUATOR to MAX. Set the System switch to A.V.C. Turn the I.F. GAIN control to the maximum clockwise position. Note: Unless the I.F. GAIN control is in the maximum position, the "S" meter calibration is upset.

Remove the plated cap below the meter.

Adjust the setting of the balance control (accessible through the hole in the panel) by means of a screwdriver until the meter reads zero.

SECTION 4

BRIEF TECHNICAL DESCRIPTION

This section describes briefly, with the aid of the block diagram in Fig. 1, the basic theory of operation. For a more detailed explanation of the receiver, Section 5 (DETAILED CIRCUIT DESCRIPTION) should be consulted.

4.1 SIGNAL INPUT

The aerial loading (75Ω unbalanced) is designed for WIDEBAND operation or pre-selected for optimum performance by the six double-tuned aerial coils selected by means of the AE. (ANT.) RANGE MC/S switch.

4.2 FIRST MIXER

Input signals between 0.98 and 30 Mc/s are fed via an r.f. amplifier and a 30 Mc/s low-pass filter to the first mixer (M1) where they are mixed with the output from a variable frequency oscillator VFO-1 (MEGACYCLES tuning). This oscillator has a frequency range of 40.5 to 69.5 Mc/s. The first i.f. stage is in effect a band-pass filter tuned to 40 Mc/s ± 650 kc/s. Thus, according to the setting of VFO-1, any spectrum of signals 1 Mc/s wide and existing in the range 0.98 to 30 Mc/s can be mixed in M1 to produce an output acceptable to the first i.f. band-pass filter.

It should be noted at this stage that the exact setting of VFO-1 is determined by conditions in the second and fourth mixer circuits; these restrict the possible settings to positions 1 Mc/s apart (e.g. 40.5, 41.5, 42.5 Mc/s, etc.).

4.3 HARMONIC GENERATOR AND MIXER

The output from a 1 Mc/s crystal oscillator is connected to a harmonic generator. The harmonics derived from this stage are passed through a 32 Mc/s low-pass filter and mixed with the output from VFO-1 in the fourth mixer (M4). This mixer provides an output at 37.5 Mc/s which is amplified before passing through a band-pass filter tuned to 37.5 Mc/s with a bandwidth of ± 150 kc/s.

The presence of this filter restricts the setting of VFO-1 to an exact number of Mc/s plus 37.5 Mc/s in order to give an output acceptable to the filter and amplifier. As a result, the first v.f.o. must be tuned in 1 Mc/s steps.

4.4 SECOND MIXER

The 40 Mc/s first i.f. signal is mixed in the second mixer (M2) with the 37.5 Mc/s output from M4 in order to produce an output consisting of a 1 Mc/s spectrum in the frequency range 2-3 Mc/s (second i.f.).

To clarify this method of operation, some examples of dial settings and intermediate frequencies corresponding to various incoming signals are tabulated below:—

Dial Mc/s	Settings kc/s	Signal Freq. f_s Mc/s	VFO-1 f_o Mc/s	Xtal Harmonic nf_c Mc/s	1st I.F. $f_o - f_s$	Het. Freq. $f_o - nf_c$ (M4 output)	2nd I.F. $nf_c - f_s$
4	1,000	5.0	44.5	7th	39.5	37.5	2.0
5	0	5.0	45.5	8th	40.5	37.5	3.0
18	600	18.6	58.5	21st	39.9	37.5	2.4

Frequency drift of VFO-1 within the limits of the 37.5 Mc/s filter bandwidth, does not affect the frequency stability of the receiver. A change in this oscillator frequency will alter the first i.f. to the same extent and in the same sense as the nominal 37.5 Mc/s signal from M4. Therefore the difference frequency from M2 will remain constant.

4.5 THIRD MIXER

The 2-3 Mc/s receiver, which follows M2, is preceded by a tuned three stage band-pass filter ganged to the second variable frequency oscillator VFO-2 (KILOCYCLES tuning). This oscillator is temperature compensated and the output is mixed in the third mixer (M3) with the 2-3 Mc/s output from the band-pass filter to provide the third and final intermediate frequency of 100 kc/s.

4.6 THIRD I.F. STAGE

The final i.f. stages are preceded by crystal lattice and L-C filters which provide six alternative bandwidths. Separate signal and a.v.c. diodes are employed and alternative switched time-constants give the optimum conditions for telegraphy and telephony reception. An additional i.f. amplifier is incorporated to give an independent output at 100 kc/s.

4.7 A.F. STAGES

Two independent audio frequency stages are incorporated for either line output or headphone sockets and internal loudspeaker; each stage is provided with a level control (see TECHNICAL SPECIFICATION).

4.8 CRYSTAL CALIBRATOR

A crystal calibrator unit is incorporated to enable the scale of VFO-2 to be checked at 100 kc/s intervals. These check points are obtained from a regenerative divider controlled by the 1 Mc/s crystal oscillator.

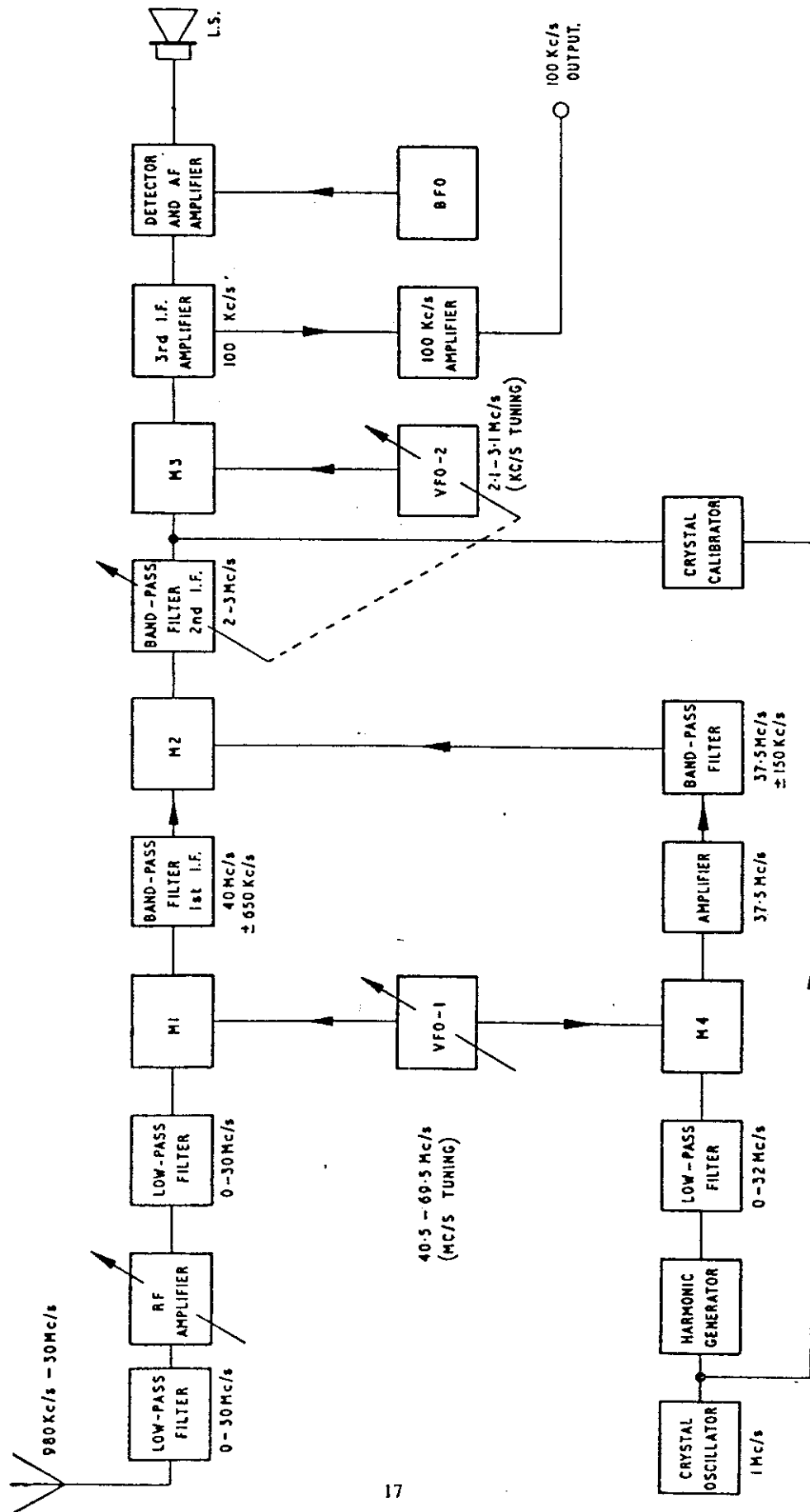

FIG. 1 BLOCK DIAGRAM OF THE RECEIVER TYPE RA.17

SECTION 5

DETAILED CIRCUIT DESCRIPTION

Reference should be made to the circuit diagram at the end of this handbook.

5.1 AERIAL CIRCUIT

A 75Ω unbalanced aerial source is connected to the tuned r.f. amplifier through a three-section 30 Mc/s low-pass filter and a five-position attenuator covering a range of 0 to 40 dB. Switch S2 selects wideband operation or any one of the six double-tuned aerial coils L4-9 for tuned operation. These aerial coils are aligned by means of dust iron cores. The aerial is tuned by a capacitor C18A/B which is switched out of circuit in the wideband position.

5.2 R.F. AMPLIFIER

The incoming signal is fed via C28 and grid stopper R25 to the grid of V3B; the r.f. stage (V3) employs a variable-mu, low-noise double-triode; the two halves of the valve are connected in cascade so as to utilize the low-noise high-gain properties of the valve. A delayed a.v.c. voltage, derived from a shunt diode network, is applied to the grid of V3B when the signal level is approximately $10\mu\text{V}$. The capacitors C40 and C41 ensure that the cathode is adequately decoupled over the wide frequency range. Ferrite beads have been fitted to the heater lead, connected to pin 4, the anode of V3A and the cathode of V3B adjacent to C41, to prevent parasitic oscillations occurring.

5.3 30 Mc/s LOW-PASS FILTER

The amplified signal is passed to a 30 Mc/s low-pass filter which has a substantially flat response over the frequency range. L27, C47 and R28 constitute the first 'L half-section' of the filter. The signal is then fed at low impedance (680Ω) through the coupling capacitor C74 and the grid stopper R45 to the control grid of V7, the first mixer stage. The input capacitance of V7 forms the capacitance to chassis between L15 and L17 required to complete the filter network.

Note : This capacitance is not critical, therefore no adjustment will be necessary should V7 be changed.

5.4 FIRST VARIABLE FREQUENCY OSCILLATOR (VFO-1)

This circuit comprises a cathode-coupled Hartley oscillator stage (V5) which may be continuously tuned over the frequency range of 40.5-69.5 Mc/s. The frequency determining components are an inductance L36 and a variable capacitance C76. Alignment is accomplished by adjusting the aluminium core of L36 and the trimming capacitor C77. The variable capacitor C76 is coupled to the Mc/s dial which is calibrated from 0 to 29 Mc/s. The anode load consists of L20, a compensating inductance which is wound on a 470Ω resistor R18. The oscillator is coupled via C85 to the signal grid of the first mixer stage V7 and also via C42 to the control grid of the harmonic mixer V4.

Note : The Mc/s dial calibration may be affected if V5 is changed. The necessary correction may be made by adjusting C77 with the Mc/s dial set to 29 Mc/s. (See Part 2, Section 5, para. 5.9).

5.5 FIRST MIXER (M1)

The outputs from the 30 Mc/s low-pass filter and the variable frequency oscillator VFO-1 are fed to the signal grid of the mixer stage (V7) which produces a signal at 40 Mc/s. The signal is then passed to a 40 Mc/s band-pass filter which forms the anode load of this stage.

5.6 40 Mc/s BAND-PASS FILTER

The 40 Mc/s band-pass filter consists of eight over-coupled tuned circuits connected in cascade and is tuned by the trimming capacitors C21, C33, C43, C53, C61, C70, C79 and C88. This filter, which has a passband of $40\text{ Mc/s} \pm 650\text{ kc/s}$, ensures that only the required 1 Mc/s spectrum of signals is passed to the second mixer stage. This filter is deliberately set to a slightly wider passband than is theoretically required, to allow for possible drift in VFO-1.

5.7 1 Mc/s CRYSTAL OSCILLATOR

The frequency of the crystal oscillator V1, which is a cathode-coupled Colpitts circuit, may be set precisely to 1 Mc/s by adjusting the trimming capacitor C2. The anode coil L2 which is adjusted to resonate at 1 Mc/s by means of a dust iron core is electron coupled to the oscillator. The fixed capacitors C9, C10 and C11 complete the tuned circuit. The output from V1 is capacitance-coupled to the harmonic generator V2, coaxial plug PL3A for feeding a 1 Mc/s input into the l.f. converter, and also to the first grid of the mixer valve V13 via PL2/SK2.

5.8 HARMONIC GENERATOR

The 1 Mc/s signal is fed through the coupling capacitor C8 to the control grid of the harmonic generator (V2). Megacycle harmonics are produced in this stage by operating the valve in a non-linear state. A suitable bias potential is produced due to the time constant of C8 and R13. The screen grid is not de-coupled.

5.9 32 Mc/s LOW-PASS FILTER

The megacycle harmonics are fed through a 32 Mc/s low-pass filter circuit to prevent harmonics other than those required from passing to the harmonic mixer (V4). Limited control over the cut-off frequency is provided by C7 which is adjusted to equalize the output from the filter at the harmonic frequencies corresponding to 28 and 29 Mc/s on the MEGACYCLE dial.

5.10 HARMONIC MIXER (M4)

The outputs from the 32 Mc/s low-pass filter and VFO-1 are mixed in the harmonic mixer (M4) by applying the filtered megacycle harmonics to the suppressor grid and the output from the VFO-1 to the control grid. The 37.5 Mc/s output is selected by the tuned anode load, consisting of a fixed capacitor C50 and an inductance L28, which may be adjusted by means of a dust iron core, and coupled by C51 to V6. R36 is a grid stopper.

5.11 2-STAGE 37.5 Mc/s AMPLIFIER (1)

The anode load of V6 is a tuned circuit consisting of a fixed capacitor C67 and an inductor L33 which is tuned to 37.5 Mc/s. Frequency adjustment is by the dust iron core in L33. This stage feeds the amplified signal via C68 to the following stage V8. The 37.5 Mc/s signal is then passed to the 37.5 Mc/s band-pass filter. The anode load of this stage is provided by this filter.

5.12 37.5 Mc/s BAND-PASS FILTER

The 37.5 Mc/s band-pass filter consists of eight under-coupled tuned circuits arranged in cascade. These filter sections may be tuned by C24, C35, C45, C55, C63, C72, C81 and C90 respectively. This filter, which has a passband of 300 kc/s, allows for possible drift in VFO-1. The narrow passband and high rejection to frequencies outside the passband prevent spurious signals from reaching the second mixer stage (V9).

5.13 37.5 Mc/s AMPLIFIER (2)

The filtered 37.5 Mc/s signal is further amplified by V10 before being passed to the second mixer stage (V9). To prevent interaction between the 40 Mc/s band-pass filter and the 37.5 Mc/s tuned circuit (L50 and C113) and to enable either circuit to be adjusted without affecting the other, a balancing circuit is included which is shown in a simplified form in figure 2.

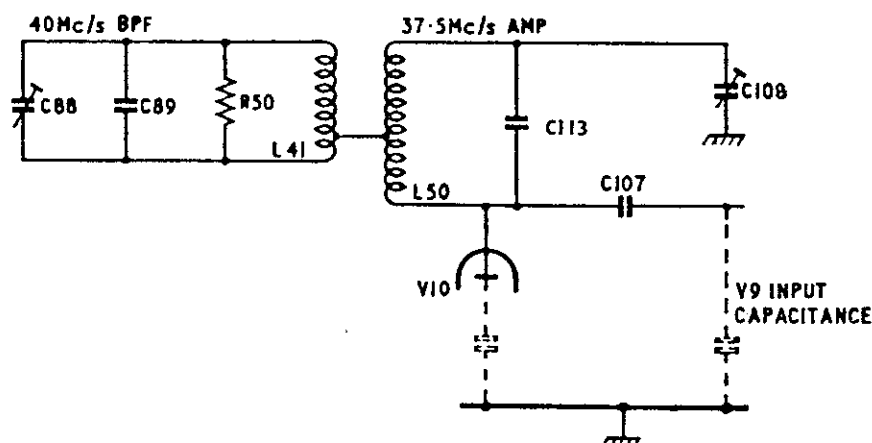

FIGURE 2

The 40 Mc/s signal is introduced into the 37.5 Mc/s tuned circuit at a point of zero r.f. potential since L50 is centre tapped and C108 is adjusted to be equal to the total of the capacitances of V10 anode to ground, C107 and the input capacitance of V9.

Notes : The anode load of V10 is adjusted to 37.5 Mc/s by adjusting the dust iron core in L50.
The balancing circuit will not be affected if V9 or V10 is changed.

5.14 SECOND MIXER (M2)

This mixer (V9) produces the second intermediate frequency of 2-3 Mc/s by mixing the 40 Mc/s i.f. and the 37.5 Mc/s signal. The anode choke L51 and the tuned circuit formed by C116 and L52 remove the 37.5 Mc/s frequency and other h.f. components, so that only the second i.f. is passed to the 2-3 Mc/s band-pass filter preceding the third mixer stage. The series tuned circuit is tuned to 37.5 Mc/s by adjusting the dust iron core in L52.

5.15 2-3 Mc/s TUNED BAND-PASS FILTER

This filter (which is ganged to the second Variable Frequency Oscillator) consists of three tuned band-pass filter sections as follows :—

- (a) An inductor L59 and a variable capacitor C129. A fixed capacitor C127 and a trimmer C128 complete this section. L59 is tapped to provide an input connection via the coaxial plug PL5 so that the 2-3 Mc/s low impedance output of the L.F. Converter may be connected.
- (b) A variable inductor L58 is connected in series with a coupling coil L60 and a variable capacitor C126. A fixed capacitor C124 and a trimmer C125 are connected in parallel with C126.
- (c) An inductor L57 and a variable capacitor C123 in parallel with a fixed capacitor C121 and a trimmer C122 form the final section.

The correct bandwidth is obtained by adjusting the dust iron cores and the trimming capacitors C128, C125 and C122 respectively.

5.16 THIRD MIXER

The output from the 2-3 Mc/s band-pass filter is directly coupled to the signal grid of a pentagrid valve V11 and the second VFO output (2.1 to 3.1 Mc/s) is fed through the coupling capacitor C143 to the oscillator grid. The resistor R68 completes the d.c. path from this grid to earth. The 100 kc/s output obtained from this mixer stage is then fed via PL6, SK6 and a screened cable to the crystal filter unit.

Note : The resistors R67 and R72 are grid stoppers.

5.17 SECOND VARIABLE FREQUENCY OSCILLATOR (VFO-2)

The second Variable Frequency Oscillator, covering a frequency range of 2.1 to 3.1 Mc/s, is an electron coupled Hartley circuit. The oscillation frequency is determined by an inductance L55 (which can be adjusted by means of a ferrite core), a fixed capacitor C137, a trimming capacitor C136 and a variable capacitor C139 which is ganged to the tuned band-pass filter. The KILOCYCLES scale which is calibrated between 0 and 1,000 kc/s is coupled to this ganged capacitor. The output from VFO-2 is resistance-capacitance coupled (R76 C143) to the third mixer stage (V11). An additional output from the cathode of VFO-2, is fed directly to a coaxial plug PL11 for feeding auxiliary units.

5.18 CRYSTAL FILTER

Six alternative switched i.f. bandwidths are available as follows:—

100 c/s } 300 c/s } Crystal	1.2 kc/s } 3.0 kc/s } 6.5 kc/s } 13.0 kc/s } L-C
--------------------------------	---

In the crystal positions the third mixer anode is connected to L48 in the crystal filter. L47 and L49 provide a balanced output which is tuned by capacitors C109 and C110. In the 100 c/s position, the balanced output is connected via crystals XL2 and XL5 to the first tuned section of the 100 kc/s L-C filter. The differential trimmer C118 is the phasing control for this bandwidth. XL3, XL6 and capacitor C119 form a similar circuit for the 300 c/s position. Damping resistors R64 and R65 are connected across the tuned circuits to obtain the required bandwidth.

In the four L-C bandwidth positions the crystal filter is by-passed and the anode of the third mixer valve (V11) is connected directly to the first tuned section of the 100 kc/s L-C filter.

5.19 100 kc/s L-C FILTER

(i) L-C Bandwidths

This filter consists of four tuned circuits arranged in cascade. In the L-C bandwidth positions, the signal is fed to the tuned circuit formed by L61 and the combination of the capacitors C145, C146, C146A and C147. The second section consists of L62 and L63 in series with C152, C152A and C153. The final section consisting of L68 and L71 in series with C161 and C162, is damped by the series resistors R86, R87, R87A and R88 according to the bandwidth. In the L-C positions the output is taken from a capacitive divider formed by C161 and C161A with C170, to equalize the gains in the L-C and crystal bandwidth positions.

The L-C bandwidths are obtained by varying the degree of coupling between each section of the filter in addition to the damping resistors in the final stage. The capacitor C175 is included to compensate for the effective reduction of the input capacitance of V14, appearing across the tuned circuit, when switching from crystal to L-C positions.

(ii) Crystal Bandwidths

To maintain the input capacitance of the L-C filter, in the crystal positions, a trimming capacitor C148 is switched into circuit. This trimmer is adjusted to be equal to the output capacitance of V11 and the screened cable.

In the crystal bandwidth positions, the L-C filter is operating in its narrow bandwidth position, *i.e.* 1.2 kc/s.

Note : The damping resistors R77 and R80 are disconnected except during filter alignment.

5.20 FIRST 100 kc/s I.F. AMPLIFIER

The output from the L-C filter is passed through a coupling capacitor C164 to the control grid of the pentode amplifier valve V14. This grid is returned via R96 to the a.v.c. line which is filtered at this point by R102 and C173. The screen potential is derived from a potential divider formed by R93, R94 and R97. This stage is coupled to the second i.f. amplifier and the i.f. output stage by a double tuned transformer having an over-coupled characteristic.

5.21 SECOND 100 kc/s I.F. AMPLIFIER

The signal from the first i.f. transformer is fed through the grid stopper R114 to the control grid of the second i.f. amplifier. H.T. is supplied to the screen via the dropping resistor R113 and is de-coupled by C181. The anode load is a tuned circuit consisting of L77, C192 and C191. This circuit is heavily damped by R112. The secondary winding L78 and L79 is tuned by C195A and C195B with R120A as a damping resistor. The output is fed to the diode detector anode.

5.22 DIODE DETECTOR

The low potential end of L79 is connected through the r.f. filter (C209, R128, C210, R129 and C211) to the diode load R130. With the meter switched to R.F. LEVEL the meter indicates the detector diode current. The resistor R131 is included to complete the diode detector circuit when the meter is switched out of circuit.

5.23 NOISE LIMITER

The noise limiter diode (pins 2 and 5 of V21) is connected in a series circuit to operate at approximately 30% modulation. Its operation is explained with reference to Figure 3.

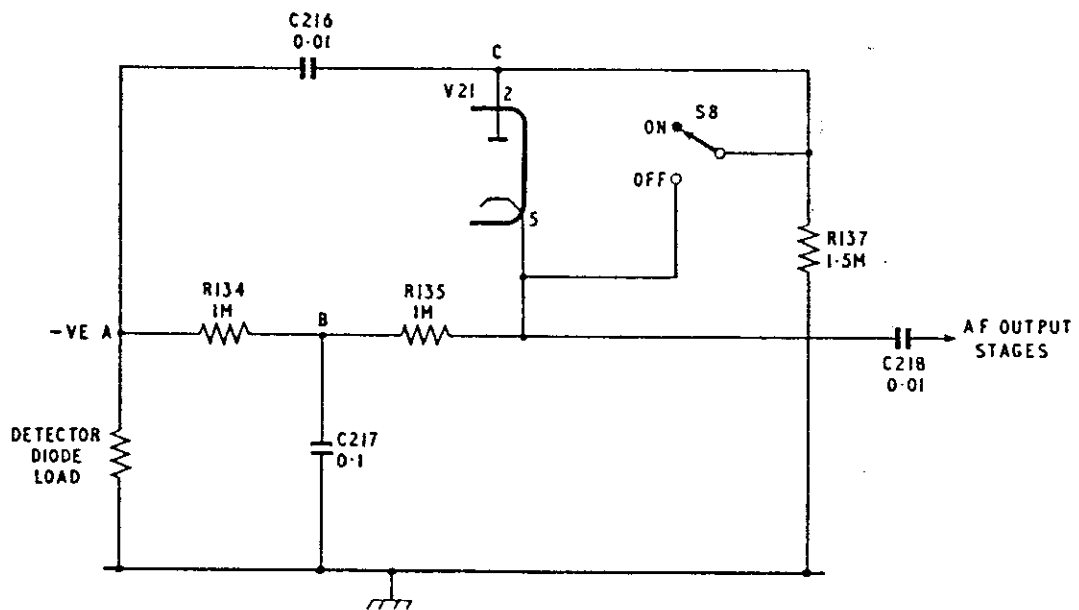

FIGURE 3

The d.c. path from point A is through R134, R135, the diode and R137. The a.f. signal path from the detector diode load is through C216, the diode and C218 when S8 is open. In the presence of a signal, a negative potential varying with the depth of modulation, will be developed at point A thus causing the diode to conduct. The negative potential at B, will be lower than that at A and will be maintained at a constant level due to the long time constant of R134 and C217. R135 allows the cathode potential to vary in sympathy with the modulation provided the modulation depth does not exceed 30%. The potential appearing at the cathode of the noise limiter diode therefore consists of a steady negative potential with the modulation superimposed. When noise impulses corresponding to high modulation peaks appear at point A and via C216 at point C, the voltage across the diode changes sign thereby causing the diode to stop conducting and open-circuit the a.f. signal path. With S8 in the OFF position the limiter is inoperative.

5.24 A.V.C. AND T.C. DIODE

The signal appearing at the anode of V16 is passed through the capacitor C193 to the anode of the a.v.c. diode. The diode load is formed by R116. A positive potential derived from R120, R121 and R122, supplies the required a.v.c. delay voltage to the cathode of this diode. When the A.V.C. switch is in the SHORT position and the System switch set to a position in which the a.v.c. is operative, i.e. A.V.C., CAL or CHECK B.F.O., the anode of the a.v.c. diode is connected to the a.v.c. line via L81 and R127. The choke L81 is tuned by C203 to a frequency slightly below 100 kc/s so that it presents a small capacitance at 100 kc/s, thus R127 is prevented from shunting the diode load. When the A.V.C. switch is in the LONG position the a.v.c. de-coupling capacitors C182 and C173 are charged through R127 and the Time Constant diode. When the signal level falls, the capacitors C182 and C173 discharge through R118, R127 and L81 into the diode load resistor R116. The a.v.c. potential is brought out via R123 to the tag strip at the rear of the receiver for external use if required. With the System switch set to the MANUAL position, the a.v.c. line is connected to the I.F. GAIN control RV1, thus the gain of the 100 kc/s amplifiers may be varied by adjusting the negative potential applied to the a.v.c. line.

5.25 AUDIO OUTPUT

Audio frequencies are applied to the control grid of V22 (V23B, North American version) via RV2 the R.F. GAIN control. The output transformer (T2) provides four separate outputs as follows: 50mW (1W, North American version) into 3 Ω , and three windings supplying 3mW into 600 Ω .

The headphone jacks JK1 and JK2 and the internal loudspeaker (which may be switched out of circuit by operating S11) are connected across the 3 Ω winding.

5.26 A.F. LINE OUTPUT

The audio frequencies are also applied to the grid of V23 (V23A, North American version) via RV3, the A.F. LEVEL control; this control presets the level from the output transformer T3. The transformer provides a 10mW output at 600 Ω which is suitable for direct connection to landlines. A bridge rectifier MRI is connected across the output via R142 and R143. The meter may be switched across the rectifier circuit so that the operator can monitor the a.f. output.

Note : The red line on the meter scale corresponds to 10mW output into 600 Ω .

5.27 BEAT FREQUENCY OSCILLATOR

The beat frequency oscillator (V19) employs an electron-coupled Hartley circuit. The oscillation frequency is determined by a fixed inductor L82 and a variable capacitor C200 in parallel with C202 and C201. The trimming capacitor C201 is adjusted to produce an output frequency of precisely 100 kc/s when the beat frequency oscillator frequency control is set to zero. Bias is applied to this valve by C199 and R125.

The b.f.o. output is coupled to the diode detector anode via C215. The b.f.o. is supplied with h.t. via S7 except when the System switch is in the CAL or STANDBY positions.

5.28 100 kc/s I.F. OUTPUT

The control grid of V17 is connected to the secondary of the first 100 kc/s i.f. transformer which feeds the stage with the 100 kc/s signal. The screen resistor R108 and the cathode bias resistor R115 are of the same values as used in the second 100 kc/s i.f. amplifier, hence the a.v.c. characteristic of this stage is identical to that of the main receiver. The anode load resistor R109 feeds the auto transformer L76 via the blocking capacitor C189. This transformer provides a 70 Ω output at PL8 and PL9 for external applications.

Note : PL8 and PL9 are connected in parallel, therefore only one 100 kc/s output is available at 75 Ω , and to avoid a mis-match the other connection should be made at high impedance.

5.29 CRYSTAL CALIBRATOR

The crystal calibrator, controlled by the 1 Mc/s crystal, feeds signals at 100 kc/s intervals to the signal grid of the third mixer stage to provide calibration check points.

The 1 Mc/s signal, fed through PL2, is connected through SK2 and the grid stopper R83 to the first grid of the mixer valve V13. The anode load consists of a 100 kc/s tuned circuit (L70 C167) and is coupled to the control grid of V15 through the capacitor C168. The anode load of V15 (L75 C177) is tuned to 900 kc/s and is coupled via C178 to the third grid of V13. V15 is heavily biased so that it functions as a frequency multiplier.

An output of 900 kc/s, appearing across the tuned circuit (L75 C177) is coupled to grid 3 of V13 thereby producing a difference frequency of 100 kc/s relative to the 1 Mc/s input. The 100 kc/s output appears across the anode tuned circuit (L70 C167) and is fed to the control grid of V15. The ninth harmonic is selected in turn by the anode tuned circuit (L75 C177) of V15 and fed back to the third grid of V13 to provide the beat frequency of 100 kc/s with the 1 Mc/s input. This crystal-controlled regenerative circuit is thus self-maintaining. The 100 kc/s output is obtained from the coil L69 which is mutually coupled to L70 and fed via the octal plug (PL7) to the third mixer V11.

5.30 POWER SUPPLIES

The conventional bi-phase half-wave rectifier circuit, employing a capacitor input filter, provides 220 volts h.t. supply. A 165 Ω resistor R124 is connected between the negative line of the power supply and earth thus providing a negative 25V d.c. supply for gain control purposes. The resistor R136 has been included to limit the peak current of V20 to a safe value. To remove mains-borne interference the capacitors C224 and C225 are included. All valve heaters and the scale illuminating lamp are supplied from the 6.3V 7A winding. The mains transformer T1 has input taps at 0, -5, -10, 110, 125, 210, 230 and 250 volts and is connected to the supply via F1 (2A), S10 and a three-pin Mk. IV plug and socket (PL10, SK10); this does not apply to North American versions of the receiver.

5.31 SYSTEM SWITCH

The following conditions exist for each setting of the System switch. The link on the h.t. adaptor terminals is assumed to be in position.

- (a) **STANDBY** S5A disconnects the h.t. from all stages and connects R119A across the h.t. as a compensating load.
- (b) **MANUAL**
 - (i) The h.t. is passed through S5A, S5B and S5C to all stages except the calibrator unit.
 - (ii) S5F connects h.t. to the b.f.o. when S7 is switched on.
 - (iii) The a.v.c. line is disconnected from the a.v.c. diode by S5D and connected to the I.F. GAIN control (RV1) by S5E.
- (c) **A.V.C.**
 - (i) (b) (i) and (b) (ii) applicable.
 - (ii) S5E renders the I.F. GAIN control inoperative.
 - (iii) S5D connects the a.v.c. line to the a.v.c. diode.
- (d) **CAL.**
 - (i) H.T. is applied via S5A, S5B and S5F to all stages except :—
 - The r.f. amplifier (V3)
 - The first v.f.o. (V5)
 - The first mixer (V7)
 - The second mixer (V9)
 - The final 37.5 Mc/s amplifier (V10)
 - The b.f.o.
 - (ii) (c) (ii) and (c) (iii) applicable.
- (e) **CHECK BFO**
 - (i) (d) (i) applicable except that h.t. is also applied to the b.f.o.
 - (ii) (c) (ii) and (c) (iii) applicable.

5.32 "S" METER

Suitable circuitry is included in North American versions only of the receiver. The meter is connected between the cathode of V16 and a point of preset (RV4) positive potential. It is calibrated to provide a reading of "S1" for a 1.25 μ V signal and ascending "S" points in approximately 4dB steps. Above "S9", divisions are in increments of 10dB. It should be remembered that only with the I.F. GAIN control at maximum is the correct calibration maintained.

PART 2
MAINTENANCE

PART 2
MAINTENANCE
INDEX

		<i>Page</i>
	WARNING	29
	TEST EQUIPMENT FOR MAINTENANCE	30
SECTION 1	SPURIOUS RESPONSES :—	
1.1	Origins of Spurious Responses	31
1.2	Checks for Spurious Responses	31
SECTION 2	VALVE DATA :—	
2.1	Valve Connections (British Version)	33
2.2	Valve Complement and Typical D.C. Voltages (British Version)	33
2.3	Valve Connections (North American Version)	34
2.4	Valve Complement and Typical D.C. Voltages (North American Version)	34
SECTION 3	FAULT DIAGNOSIS:—	
3.1	Introduction	37
3.2	Test Equipment Requirements	37
3.3	Fault Diagnosis	37
SECTION 4	REPRESENTATIVE TEST DATA	39
SECTION 5	ALIGNMENT PROCEDURES :—	
5.1	General	41
5.2	100 kc/s I.F. Strip	41
5.3	Second V.F.O.	42
5.4	B.F.O.	43
5.5	Second I.F. Circuit	43
5.6	37.5 Mc/s Filter and Amplifier	43
5.7	1 Mc/s Crystal Oscillator	43
5.8	Second Mixer Drive Level	43
5.9	First V.F.O. Calibration	43
5.10	Aerial Circuit	44
5.11	Crystal Calibrator	44
5.12	40 Mc/s Filter	44
5.13	Receiver Overall Gain Test	45
SECTION 6	DISMANTLING AND REPLACEMENT PROCEDURES:—	
6.1	Unit Breakdown	47
6.2	Dismantling Instructions	47
6.3	Valve Replacement	48
SECTION 7	ILLUSTRATIONS—INDEX	49
SECTION 8	LIST OF CIRCUIT COMPONENTS:—	
8.1	Resistors	53
8.2	Potentiometers	56
8.3	Capacitors	56
8.4	Switches	61
8.5	Plugs and Sockets	62
8.6	Valves (British)	63
8.7	Valves (American)	63
8.8	Valve and Crystal Holders	63
8.9	Inductances	64
8.10	Transformers	66
8.11	Rectifiers	66
8.12	Loudspeakers	67
8.13	Meters	67
8.14	Crystals	67
8.15	Fuses and Fuseholders	67
8.16	Lamp and Holder	67
8.17	Voltage Selectors	67
8.18	Supplementary Components and Sub-Assemblies	67
8.19	Main Sub-Units	69

WARNING

The Receiver will, under normal conditions, remain in alignment over an extremely long period of time, consequently ALL POSSIBILITY OF OTHER CAUSES OF LOW SENSITIVITY SHOULD BE ELIMINATED BEFORE RE-ALIGNMENT IS CONSIDERED, and should then only be undertaken by order of the Engineer responsible for the maintenance of the equipment.

Should it become necessary to re-align any part of the receiver only a very small angular adjustment of the trimmers should be necessary unless units have been changed.

TEST EQUIPMENT REQUIRED FOR MAINTENANCE

The following items of test gear are required to carry out the maintenance described in this part of the handbook :—

- (a) Valve voltmeter reading up to 5·0V at frequencies up to 70 Mc/s
- (b) Signal generator capable of operating on fundamental frequencies up to 40 Mc/s
- (c) Digital frequency meter measuring frequencies at least up to 100 kc/s
- (d) Multi-meter measuring a.c. and d.c. quantities up to 500V with resistance of 20,000 Ω per volt
- (e) Heterodyne wavemeter measuring 40–70 Mc/s
- (f) Miscellaneous: viz. 0·1 μ F capacitor, 4·7k Ω resistor and 12pF trimmer capacitor.

Note : Major users of the RA.17 Receiver are advised to obtain factory-type test jigs for alignment of the various units. Details of these jigs and specially designed test gear will be supplied on request. A supplement to Section 5 (Alignment Procedures) describing the employment of this test gear can be made available to such users.

SECTION 1

SPURIOUS RESPONSES

1.1 ORIGINS OF SPURIOUS RESPONSES

In a highly sensitive receiver, precautions against internally generated spurious responses are essential. To this end, the various sections of the receiver have been carefully screened and the power supplies filtered.

Any reduction in the screening efficiency or the failure of any filtering component may result in spurious signals being generated. It is therefore essential to ensure that the bonding surfaces are clean and that all securing screws are tight. Spurious responses in the receiver may occur from the following main causes:—

- (a) 37·5 Mc/s break-through from the second mixer V9 to the third mixer V11
- (b) Break-through of 1 Mc/s harmonics
- (c) Break-through of b.f.o. harmonics
- (d) Responses at 2·550 and 3·050 Mc/s due to second v.f.o. break-through.

1.2 CHECKS FOR SPURIOUS RESPONSES

Spurious responses are measured relative to receiver noise in the following manner:—

When a response is located, the receiver is de-tuned from it just sufficiently to render the beat note inaudible. The i.f. gain is then adjusted to provide a convenient noise reference output (1mW) and the receiver re-tuned to the spurious signal for maximum output. The dB rise in audio output is a measure of the spurious signal level relative to receiver noise.

Standard conditions of test :

- No connection to aerial socket
- System switch to MAN
- I.F. GAIN at MAX
- B.F.O. on
- 3 kc/s bandwidth
- AE (ANT.) ATTENUATOR at MIN.

(a) 37·5 Mc/s Break-through to Third Mixer

Switch AE (ANT.) RANGE to WIDEBAND.

This response will be indicated as a beat note which varies rapidly in frequency with respect to the KILOCYCLES scale, *i.e.* a change of 1 kc/s on the scale results in a much larger change in the note. It will also move along the KILOCYCLES scale if the MEGACYCLES dial is adjusted slightly. This response may be eliminated by adjusting the 37·5 Mc/s trap (LS2 at second mixer anode).

(b) 1 Mc/s Harmonic Break-through

Switch AE (ANT.) RANGE to WIDEBAND.

1 Mc/s break-through responses appear at 0 and 1,000 on the KILOCYCLES scale at each setting of the MEGACYCLES dial and are generally more prominent with wideband input. If the response is dependent upon the setting of the MEGACYCLES dial, the 1 Mc/s spectrum is probably breaking through to the first mixer stage. If the response is independent of the MEGACYCLES dial setting, it is due either to break-through of the second and/or third harmonic to the second or third mixer stage. Remove second mixer valve to eliminate this stage and so determine in which stage the break-through occurs.

(c) First V.F.O. Harmonics

Spurious responses may occur at 4·5, 5·5 and/or 17·5 Mc/s, if C42A and/or C194A are open-circuit. These responses are caused by the harmonics of the first v.f.o. breaking through to the second mixer stage and beating with the harmonics of the 37·5 Mc/s heterodyne voltage.

(d) B.F.O. Harmonics

These responses may be detected at 100 kc/s intervals between 1 and 1·5 Mc/s when the b.f.o. frequency is 100 kc/s and the receiver aerial input is tuned.

(e) Second V.F.O. Break-through

Responses may occur at 2·550 and 3·050 Mc/s with tuned aerial input.

Ascertain that the first and second v.f.o. are not in contact, that the v.f.o. chassis is well bonded to the main chassis and the fixing screws are tight.

Notes: A failure in any one of the following capacitors C66, C92, C96, C97, C98, C103 or C104 may result in increased 'end of band' responses. These responses will disappear when the MEGACYCLE dial is de-tuned.

The failure of C117, C154, C155, C207, C208 or C214 can result in increased 'end of band' responses, or b.f.o. harmonic break-through. De-tuning the MEGACYCLES dial will have no effect.

SECTION 2

VALVE DATA

Details of valves used in the British and American receiver are shown below. A key to the valve base connections is provided in Figure 4. The location of valves in the receiver is shown in Figure 5.

2.1 VALVE CONNECTIONS (British Version)

Pin No.	CV138	CV140	CV1377	CV4012	CV454	CV2209	CV3998	CV5331
1	EF91 Grid 1	EB91 Cathode 1	GZ34 N.C.	EK90 Grid 1	EF93 Grid 1	6F33 Grid 1	E180F Cathode	ECC189 Anode 2
2	Cathode	Anode 2	Heater	Cathode & Grid 5	Grid 3	Cathode	Grid 1	Grid 2
3	Heater	Heater	Omitted	Heater	Heater	Heater	Cathode	Cathode 2
4	Heater	Heater	Anode	Heater	Heater	Heater	Heater	Heater
5	Anode	Cathode 2	Omitted	Anode	Anode	Anode	Heater	Heater
6	Grid 3 & Screen	Screen	Anode	Grid 2 & Grid 4	Grid 2	Grid 3 & Diode	I.C.	Anode 1
7	Grid 2	Anode 1	Omitted	Grid 3	Cathode	Grid 2	Anode	Grid 1
8	—	—	Heater	—	—	—	Grid 3 & Screen	Cathode 1
9	—	—	—	—	—	—	Grid 2	Screen
Base	B7G	B7G	Int. Octal	B7G	B7G	B7G	B9A	B9A

2.2 VALVE COMPLEMENT AND TYPICAL D.C. VOLTAGES (British Version)

Cct. Ref.	Function	CV No.	Equivalent	Anode	Screen	Cathode	Cct. Ref.
V1	Crystal Oscillator	138	EF91	175 (5)	175 (7)	40 (2)	V1
V2	Harmonic Generator	138	EF91	195 (5)	70 (7)	—	V2
V3	R.F. Amplifier	5331	ECC189	185 (1)	—	1.0 (8)	V3
				95 (2) Grid			
				95 (6)			
V4	Harmonic Mixer	2209	6F33	200 (5)	150 (7)	1.95 (2)	V4
V5	First V.F.O.	138	EF91	210 (5)	200 (7)	—	V5
V6	37.5 Mc/s Amplifier	138	EF91	205 (5)	150 (7)	1.15 (2)	V6
V7	First Mixer	3998	E180F	190 (7)	140 (9)	0.95 (1)	V7
V8	37.5 Mc/s Amplifier	138	EF91	200 (5)	185 (7)	1.8 (2)	V8
V9	Second Mixer	3998	E180F	200 (7)	155 (9)	1.1 (1)	V9
V10	37.5 Mc/s Amplifier	138	EF91	205 (5)	200 (7)	1.85 (2)	V10
V11	Third Mixer	4012	EK90	210 (5)	85 (6)	1.18 (2)	V11
V12	Second V.F.O.	138	EF91	175 (5)	115 (7)	—	V12
V13	Calibrator	4012	EK90	250 (5)	90 (6)	2.0 (2)	V13
V14	First I.F. Amplifier	454	EF93	190 (5)	65 (6)	0.8 (7)	V14
V15	Calibrator	454	EF93	230 (5)	130 (6)	6.0 (7)	V15
V16	Second I.F. Amplifier	454	EF93	200 (5)	95 (6)	1.45 (7)	V16
V17	I.F. Output	454	EF93	170 (5)	105 (6)	1.35 (7)	V17
V18	A.V.C. and T.C.	140	EB91	—	—	28.0 (1)	V18
V19	B.F.O.	138	EF91	180 (5)	220 (7)	—	V19
V20	Power Rectifier	1377	GZ34	250 r.m.s. (6)	—	250 (8)	V20
				250 r.m.s. (4)			
V21	Detector and Noise Limiter	140	EB91	—	—	—	V21
V22	Audio Output	138	EF91	210 (5)	220 (7)	2.1 (2)	V22
V23	A.F. Output	138	EF91	210 (5)	220 (7)	2.1 (2)	V23
V24		469	EA76	—	—	—	V24

2.3 VALVE CONNECTIONS (North American Version)

Pin No.	6AU6	6SE8	6688	6AS6	6BE6	6BA6	6AL5
1	Grid 1	Anode 2	Cathode	Grid 1	Grid 1	Grid 1	Cathode 1
2	Grid 3 & Screen	Grid 2	Grid 1	Cathode	Cathode & Grid 5	Grid 3 & Screen	Anode 2
3	Heater	Cathode 2	Cathode	Heater	Heater	Heater	Heater
4	Heater	Heater	Heater	Heater	Heater	Heater	Heater
5	Anode	Heater	Heater	Anode	Anode	Anode	Cathode 2
6	Grid 2	Anode 1	I.C.	Grid 2	Grid 2 & Grid 4	Grid 2	Screen
7	Cathode	Grid 1	Anode	Grid 3	Grid 3	Cathode	Anode 1
8	—	Cathode 1	Grid 3 & Screen	—	—	—	—
9	—	Screen	Grid 2	—	—	—	—
Base	B7G	B9A	B9A	B7G	B7A	B7G	B7G

2.4 VALVE COMPLEMENT AND TYPICAL D.C. VOLTAGES (North American Version)

Cct. Ref.	Function	Type	Anode	Screen	Cathode	Cct. Ref.
V1	Crystal Oscillator	6AU6	175 (5)	175 (6)	45.0 (7)	V1
V2	Harmonic Generator	6AU6	195 (5)	40.0 (6)	—	V2
V3	R.F. Amplifier	6ES8	190 (1) (2) 100 (6)	—	1.0 (8)	V3
V4	Harmonic Mixer	6AS6	165 (5)	120 (6)	2.0 (2)	V4
V5	First V.F.O.	6AU6	215 (5)	155 (6)	—	V5
V6	37.5 Mc/s Amplifier	6AU6	205 (5)	105 (6)	0.85 (7)	V6
V7	First Mixer	6688	195 (7)	145 (9)	0.86 (1)	V7
V8	37.5 Mc/s Amplifier	6AU6	205 (5)	110 (6)	0.81 (7)	V8
V9	Second Mixer	6688	195 (7)	155 (9)	0.91 (1)	V9
V10	37.5 Mc/s Amplifier	6AU6	210 (5)	115 (6)	0.91 (7)	V10
V11	Third Mixer	6BE6	220 (5)	88 (6)	1.25 (2)	V11
V12	Second V.F.O.	6AU6	170 (5)	105 (6)	—	V12
V13	Calibrator	6BE6	245 (5)	100 (6)	2.05 (2)	V13
V14	First I.F. Amplifier	6BA6	195 (5)	60 (6)	0.75 (7)	V14
V15	Calibrator	6BA6	240 (5)	120 (6)	7.0 (7)	V15
V16	Second I.F. Amplifier	6BA6	195 (5)	95 (6)	1.55 (7)	V16
V17	I.F. Output	6BA6	160 (5)	95 (6)	1.6 (7)	V17
V18	A.V.C. and T.C.	6AL5	—	—	27.5 (1)	V18
V19	B.F.O.	6AU6	190 (5)	150 (6)	—	V19
V21	Detector and Noise Limiter	6AL5	—	—	—	V21
V22	Audio Output	6AQ5	175 (5)	180 (6)	8.0 (2)	V22
V23	Audio Amplifier and A.F. Output	12AT7	220 (1) 110 (6)	—	3.0 (3) 1.65 (8)	V23
V24			—	—	—	V24

Voltages were obtained from a B9A or B7G stand-off valve base using a 20,000 Ω /volt meter on the optimum range in each case. Valve pin numbers are indicated in brackets.

The receiver was set as follows:

- System switch to MAN.
- I.F. and A.F. GAIN to MAX.
- No signal i.e. 1st and 2nd v.f.o. off tune.
- LIMITER off.
- B.F.O. off except for checking V19.
- System switch to CAL. in order to check V13 and V15 only.

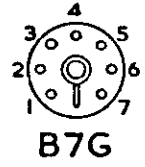
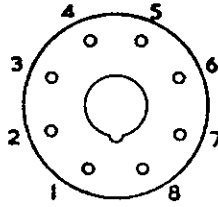
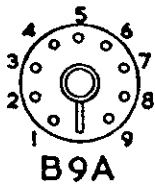

INTERNATIONAL
OCTAL

VALVE BASE CONNECTIONS

(ALL VALVE HOLDERS VIEWED FROM UNDERSIDE)

FIGURE 4

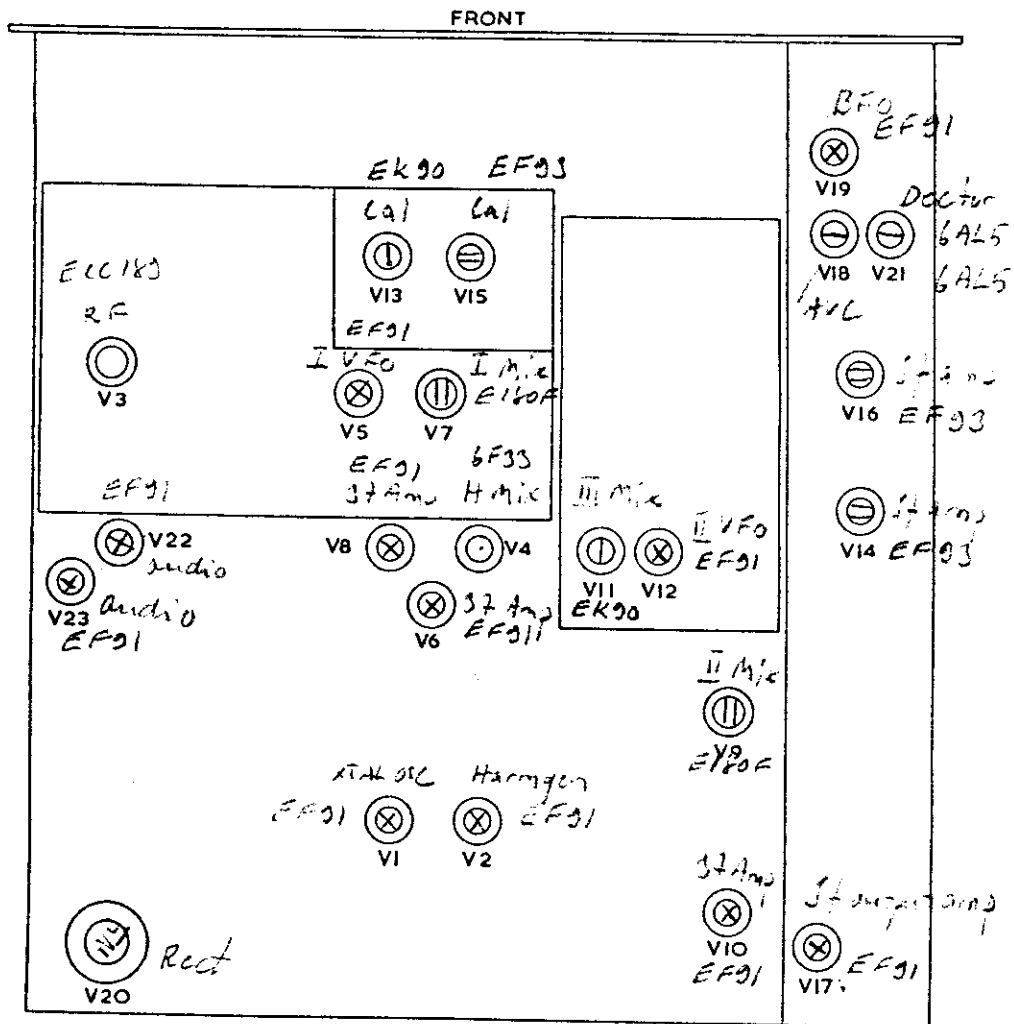

RA17 VALVE LOCATION DIAGRAM

(VIEW FROM ABOVE)

FIGURE 5

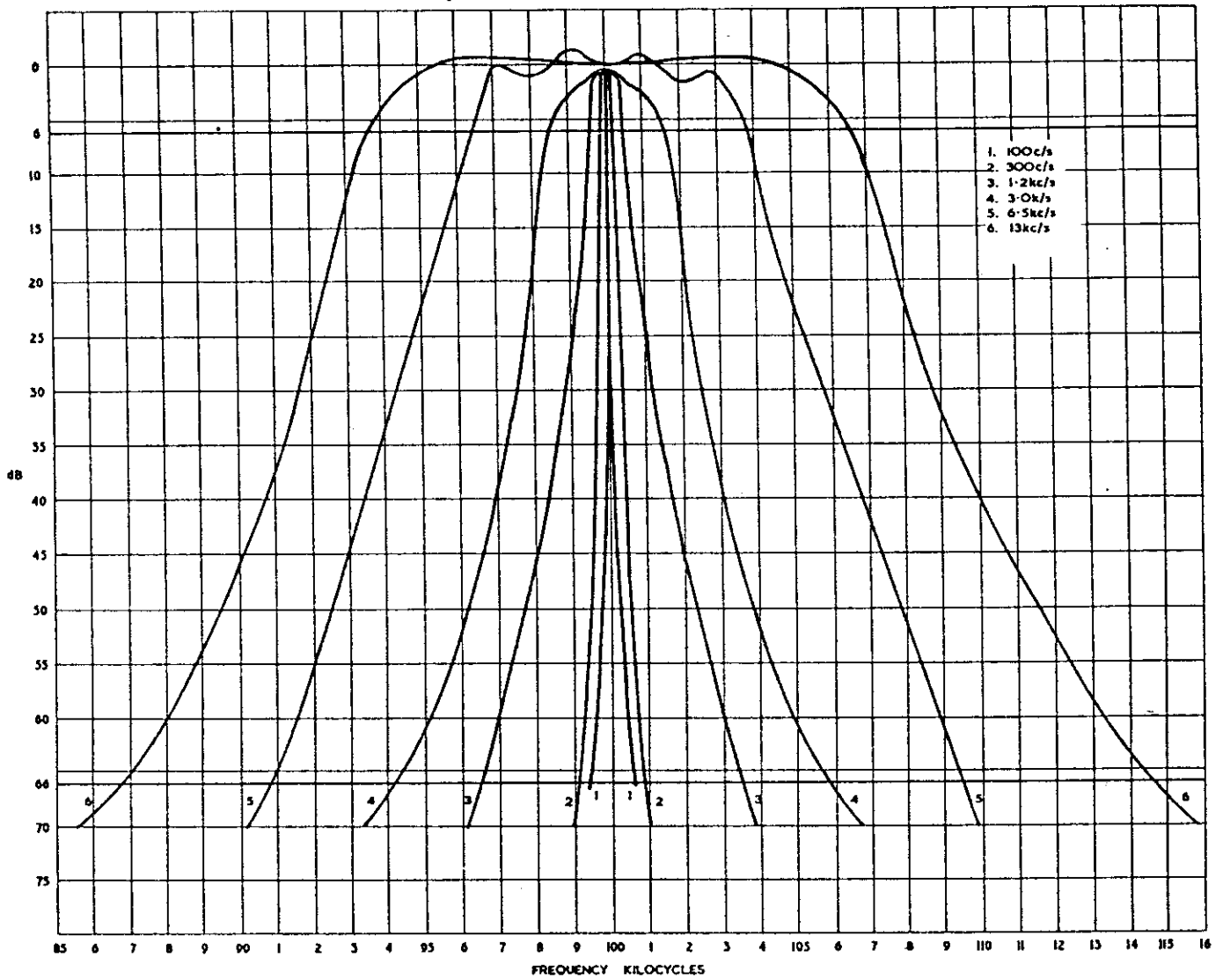

126013

Typical selectivity curves

Fig.6

SECTION 3

FAULT DIAGNOSIS

3.1 INTRODUCTION

The following notes and test procedures enable the faulty section of the receiver to be determined with the minimum of delay. Unless otherwise stated the meter on the front panel is used for measuring purposes. This is set to R.F. LEVEL and the reference figure is 100 μ A for all sensitivity tests.

Since the audio stages of the receiver are conventional and accessible, normal practice will serve to trace any fault which may occur in this section.

3.2 TEST EQUIPMENT REQUIREMENTS

The following test equipment will be required:

- (1) Valve Voltmeter.
- (2) 12pF trimmer capacitor.
- (3) Signal generator.

Note: The input capacitance of the valve voltmeter must be padded to 12pF by the trimmer or alternatively by a fixed capacitor. Before the value of the trimmer or the fixed capacitor can be selected, the input capacitance of the valve voltmeter must be known. If the trimmer is used, this should be connected across a capacitance bridge and set to the required value.

3.3 FAULT DIAGNOSIS

Set the controls on the front panel as follows:—

- R.F. GAIN to max.
- I.F. GAIN to max.
- B.F.O. switch to off.
- LIMITER switch to OFF.
- System switch to MAN.

Remove the valve V12 and crystal XL1 and connect the output of the signal generator via a 0.1 μ F capacitor to pin 5 (anode) of the valve holder V12.

Set the BANDWIDTH control to 100 c/s and tune the signal generator for maximum indication in the r.f. level meter at 100 kc/s. The sensitivity should be approximately as follows:—

3 kc/s less than 200 μ V

100 c/s

300 c/s

1.2 kc/s

6.5 kc/s

13.0 kc/s

To be within 10dB of sensitivity measured on 3 kc/s position.

In the event of the figures above not being realized, the renewal of one or more of the following valves will probably effect an improvement:

- V11 3rd mixer.
- V14 first i.f. amplifier.
- V16 second i.f. amplifier.

Refit the valve V12 and connect the output of the signal generator to test point TP3. Set the BANDWIDTH control to 3 kc/s. Tune the generator for maximum at each of the following kc/s scale settings.

Receiver kc/s scale

100

500

800

Signal generator

2.9 Mc/s less than 10 μ V

2.5 Mc/s less than 10 μ V

2.2 Mc/s less than 10 μ V

The maximum difference between check points should not exceed 3dB. The renewal of V11 or V9 will probably effect an improvement if this figure is not met, providing that the conditions outlined in previous paragraphs have been achieved. If the figures vary by more than 3dB between check points, the 2-3 Mc/s band-pass filter C122, C125, C128, L57, L58 and L59/60 should be carefully re-aligned as detailed under "Alignment Procedures" (Section 5, para. 5.5).

Refit the crystal XL1 and check the 1 Mc/s output (PL3A at the rear of the receiver) with the valve voltmeter to ensure that there is at least 2V output.

Remove the valve V9 and connect the valve voltmeter to test point TP3. Tune the MEGACYCLES dial slowly through each Mc/s point when at least 2V should be indicated on the voltmeter at each point. Absence of drive at this point or a low reading indicates a possible fault in any one of the following valves or the associated circuitry:

V2, V4, V6, V8, V10 and V5.

With V9 and the crystal XL1 removed and the valve voltmeter connected to TP3, connect the output of the signal generator at a frequency of 3.5 Mc/s to the aerial socket. With the AE. RANGE switch set to WIDEBAND and the AE. ATTENUATOR set to MIN, peak the MEGACYCLES tuning at 3 Mc/s for maximum on the valve voltmeter. The input required for 0.5V should be less than 250mV. If this figure cannot be achieved V1 and V7 may have low emission or a fault may exist in the associated circuit.

Low r.f. channel gain may be caused by a failure in the 40 Mc/s band-pass filter. This, however, is extremely unlikely and no attempt should be made to touch this section unless a wobulator is available.

The aerial, r.f. circuits and low-pass filter may be by-passed by feeding in a signal to test point TP2 on the first v.f.o. chassis.

Should the fault be traced to a section where alignment will be affected by servicing, reference should be made to the relevant part in Section 5.

Voltages on valves where the bases are inaccessible are measured by the use of short "stand offs"

SECTION 4

REPRESENTATIVE TEST DATA

<i>Signal Input to :</i>	<i>Frequency</i>	<i>Input</i>	<i>Output</i>	<i>Remarks</i>
(a) Grid V22	1,000 c/s	0.3V	50mW in 3Ω	} AUDIO GAIN MAX. A.F. LEVEL MAX. I.F. GAIN MIN. B.F.O. off. LIMITER off.
Grid V23	1,000 c/s	0.35V	10mW in 600Ω (Output to line)	
(b) Grid V16	100 kc/s c.w.	360mV	100μA R.F. level	} B.F.O. off. System Switch MAN. I.F. GAIN MAX. 1 Mc/s crystal removed. Mc/s scale set to 20. BANDWIDTH 3 kc/s.
Grid V14	100 kc/s c.w.	850μV	100μA R.F. level	
Anode Connection of V12 via 0.1μF with valve removed	100 kc/s c.w.	100μV	100μA R.F. level	
(c) Grid of second mixer. (TP3)	2.2 Mc/s c.w. 2.5 Mc/s c.w. 2.9 Mc/s c.w.	7μV 7.5μV 7μV	100μA R.F. level 100μA R.F. level 100μA R.F. level	} Image response (<i>i.e.</i> receiver frequency plus 200 kc/s) should be at least 60dB down.
(d) Aerial input (WIDEBAND)	3.5 Mc/s c.w.	250mV	0.5V at TP2	} WIDEBAND INPUT. AE (ANT.) ATTENUATOR MIN. V5 and V7 removed. Valve voltmeter input shunt- ed to 12pF.
(e) Aerial Input (WIDEBAND)	3.5 Mc/s c.w.	250mV	0.5V at TP3	} WIDEBAND INPUT. AE (ANT.) ATTENUATOR MIN. V5 and V7 replaced. V9 and 1 Mc/s crystal re- moved. Valve voltmeter input shunt- ed to 12pF. MEGACYCLES scale 3.
(f) Grid V10 Grid V8 TP1	37.5 Mc/s c.w.	40mV 25mV 2.8mV	1V at TP3	} V9 and V5 and 1 Mc/s crystal removed. Valve voltmeter input shunt- ed to 12pF.

(g) With the 1 Mc/s crystal in place, the output at plugs PL2 and PL3 should be approximately 2 volts.

(h) The level of the 37.5 Mc/s drive at TP3 should be between 2 and 10 volts at any MEGACYCLE setting.

SECTION 5

ALIGNMENT PROCEDURES

5.1 GENERAL

The receiver will, under normal conditions, maintain the factory alignment over an extremely long period of time. Consequently ALL POSSIBILITY OF OTHER CAUSES OF TROUBLE SHOULD BE ELIMINATED BEFORE RE-ALIGNMENT IS CONSIDERED.

If it becomes necessary to re-align any part of the receiver, only a very small angular adjustment of any trimmer should be necessary. The signal generator must have a high degree of frequency resetting accuracy and be very stable.

Unless otherwise stated, the panel-mounted R.F. Level meter is used as the output indicator.

5.2 100 kc/s I.F. STRIP

(a) First and Second I.F. Amplifier

Remove the second v.f.o. valve V12. Set the System switch to MAN, the I.F. GAIN to MAX and the meter switch to R.F. LEVEL. Connect the signal generator (100 kc/s c.w.) via a 0.1 μ F capacitor to the grid of V16 (Pin 1). Adjust C195B to obtain maximum indication on the meter. The output from the generator required to produce 100 μ A deflection on the meter should be approximately 320mV. Connect the signal generator via a 0.1 μ F capacitor to the grid of V14 (Pin 1) and connect a 4.7k Ω damping resistor across L72. Adjust C179 and C195B to give maximum indication.

Remove the 4.7k Ω resistor from L72 and connect it across L73. Adjust C171 for maximum indication. Remove the 4.7k Ω resistor. The signal generator output required to produce a 100 μ A deflection should be approximately 800 μ V. Tune the signal generator through the passband and note the 'double peak' response. The peak separation should be approximately 9 kc/s and be symmetrical about 100 kc/s. If the peak amplitudes differ, slight re-adjustment of C191 will compensate for this. The 6dB bandwidth should be approximately 14 kc/s.

(b) 100 kc/s (L-C) Filter

Remove the second v.f.o. valve V12 and set the controls as in 5.2 (a). Connect the output of the signal generator (100 kc/s) via a 0.1 μ F capacitor to pin 5 (anode) of V12. Remove the L-C filter can. Locate the two red free-ended leads connected at one end of the trimming capacitors C153 and C158 in the second and third sections of the filter and connect the free ends to their respective 470k damping resistor R77 and R80 at the terminal post ends. Replace the filter can. Set the bandwidth to 100 c/s. Tune the signal generator to give maximum indication in the R.F. LEVEL meter then switch to 1.2 kc/s. The frequency of this setting should be within ± 100 c/s of 100 kc/s. Adjust the trimming capacitors C162, C158, C153 and C147 in this order several times until maximum output is obtained.

Remove the L-C filter can and disconnect the red leads from the terminal post ends of the 470k Ω resistors. Replace the filter can. Set the controls of the signal generator for an output of 225 μ V approximately for 100 μ A in the R.F. LEVEL meter. Check that the bandwidths agree (approximately) with the following figures:—

-6dB	-66dB	Sensitivity for 100 μ A
100 c/s	Less than 1.5 kc/s	150 μ V
300 c/s	Less than 2.0 kc/s	200 μ V
1.2 kc/s	8 kc/s	225 μ V
3.0 kc/s	15 kc/s	160 μ V
6.5 kc/s	20 kc/s	200 μ V
13.0 kc/s	28 kc/s	350 μ V

(c) Crystal Filter

Remove the second v.f.o. valve V12 and set the controls as in 5.2 (a). Set the BANDWIDTH switch to 300 c/s. Connect the signal generator via a 0.1 μ F capacitor to pin 5 (anode) of V12. Tune the signal generator slowly through the pass-band and observe the crystal responses (f1 and f2). Care must be taken as the tuning of these is very sharp. Retune the signal generator to the mean of f1 and f2 and adjust C110 and C148 for maximum output. Reset the signal generator frequency to 100 kc/s and adjust the output to produce a reading of 100 μ A. Set the generator frequency to 101,025 c/s, increase the output by 66dB and adjust the phasing control C119 to obtain minimum output (i.e. the point of rejection occurs). Increase the generator frequency slowly and ascertain that the meter reading does not exceed 100 μ A. Slowly decrease the signal frequency until 100 μ A reading is obtained and check that the frequency is not greater than 100,900 c/s. Tune through the pass-band, adjusting the signal generator output as necessary to avoid meter damage. Note the highest frequency at which a signal generator output equal to that used at 101,025 c/s gives an output of 100 μ A. This frequency should not be less than 99,100 c/s.

Slowly decrease the signal frequency and ensure that the output does not rise above 100 μ A. Decrease the generator output by 66dB and re-check the frequency response within the pass-band, re-adjusting C110 and C148 if necessary. Set the signal generator frequency to 100 kc/s and adjust the output for 100 μ A level. Increase the signal generator output by 6dB and check the bandwidth for 100 μ A output. The bandwidth should be between 270 and 330 c/s and the mid-position should not deviate from 100 kc/s by more than 25 c/s. The sensitivity should be approximately 200 μ V for 100 μ A deflection.

Switch the BANDWIDTH control to 100 c/s. Repeat the procedure with signal generator frequency settings of 100,925 c/s, 100,800 c/s and 99,200 c/s. Adjust the phasing capacitor C118 only. The 6dB bandwidth should be between 80 and 120 c/s, and the deviation from the mean less than 25 c/s. For 100 μ A output, the input should be approximately 150 μ A.

Disconnect the signal generator and refit V12.

(d) Use of Digital Frequency Meter

The alignment of the i.f. strip and in particular the crystal filter involves the measurement of frequencies to far greater accuracies than those normally obtainable from signal generators. A digital frequency meter should therefore be employed. The equipment should be connected to SK8 or SK9. The exact frequency passing through the circuit will be displayed on the indicator panel. Should the level of output at any time during the alignment procedure be insufficient to drive the frequency meter, the signal generator output can be increased to obtain the frequency check but must be restored to the lower value for level measurements. When such increases are made, the meter on the receiver panel should be switched to A.F. LEVEL to avoid damage.

5.3 SECOND V.F.O.

(a) Minor Corrections

The variable capacitor has been carefully adjusted and should not be readjusted unless absolutely necessary. Minor corrections can be made as follows:—

- (i) Set the System switch to CAL.
- (ii) Set the KILOCYCLES cursor in line with the MEGACYCLES cursor (*i.e.* central).
- (iii) Ensure that the B.F.O. switch is off.
- (iv) Rotate the I.F. GAIN to MAX.
- (v) Set the BANDWIDTH switch to 3 KC/S.
- (vi) Set the KILOCYCLES scale to zero (0 KC/S) and adjust the capacitor C136 to give zero-beat note in the loudspeaker.
Note: The capacitor C136 is obscured by V16.
- (vii) Set the KILOCYCLES scale to that zero-beat point which is nearest to the 1,000 KC/S position.
- (viii) Lock the drive sprocket.
- (ix) Adjust the position of the film scale to produce correct calibration.
Note: When moving the film scale relative to the sprockets, grip both sides of the film scale in order to create a loop which will allow the film to slide round the drive sprocket; the drive sprocket is on the left when facing the receiver and hence movement of the film scale will have to be to the left.
- (x) Repeat (vi) to (ix) until an adequate degree of accuracy is obtained.

Important Note: The tuning slug of L55 has been sealed by the manufacturer and must not be touched under any circumstances.

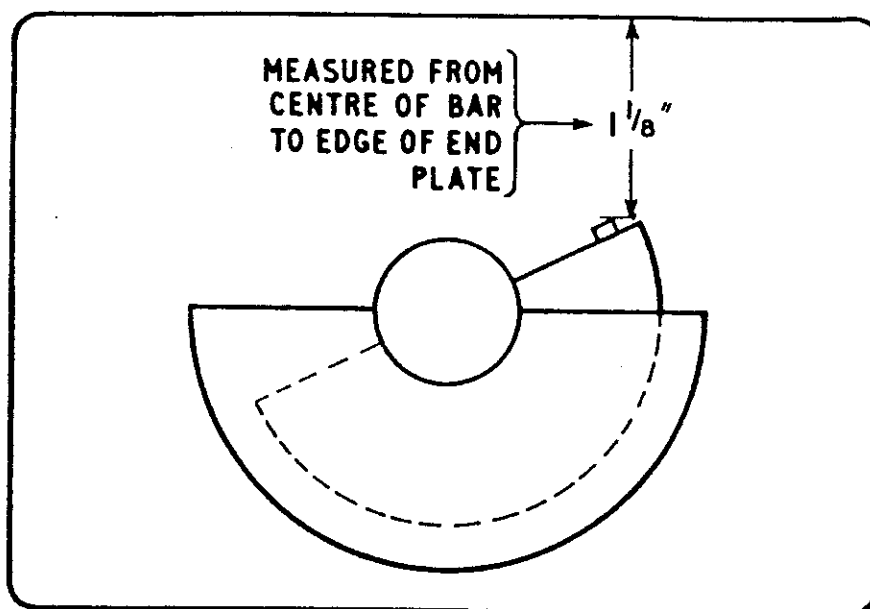

FIGURE 7

(b) Replacement of Ganged Capacitor

The procedure described below should not normally be carried out unless the ganged capacitor is being replaced. Before electrical adjustment, the following mechanical points should be verified :—

- (i) Set the KILOCYCLES scale against the mechanical end stop at the 1,000 kc/s end and check that the ganged capacitor is set as shown in Figure 7.
- (ii) Check that the distance from the cursor to the extreme end of the scale, adjacent to the 1,000 kc/s point, is approximately $\frac{1}{2}$ -in. Should this distance vary appreciably from $\frac{1}{2}$ -in., carefully lift the scale from the drive and move the scale round to the required position.
- (iii) Whenever the film scale is replaced, endeavour to re-align by adjusting the film to the correct position before trimming.

The procedure for electrical adjustment is carried out as follows:—

- (iv) Proceed as in 5.3 (a) above.
- (v) Check the calibration of the v.f.o. at 100 kc/s intervals; if the error exceeds 1 kc/s, adjust carefully the two outer plates of the rotor of the oscillator section of the ganged capacitor in order to correct the calibration.

Note: The oscillator capacitor C139 is the second section from the rear of the ganged capacitor unit.

5.4 B.F.O.

Set the System switch to the CHECK B.F.O. position. Switch the meter switch to R.F. LEVEL. Switch the b.f.o. on and set the b.f.o. frequency control knob to zero. Adjust C201 as necessary to obtain zero-beat. Observe that the meter reads approximately half f.s.d.

If the b.f.o. frequency control knob has been removed, adjust the frequency capacitor for zero-beat with the identification mark on the shaft uppermost. Replace the knob so that the pointer indicates zero.

5.5 SECOND I.F. CIRCUIT

Set the System switch to MAN. Remove the 1 Mc/s crystal. Set the I.F. GAIN to MAX. Set the METER switch to R.F. LEVEL. Connect the signal generator (c.w. output) to TP3. Alignment frequencies are 2.2 and 2.9 Mc/s which correspond to 800 and 100 kc/s respectively on the KILOCYCLES dial. Adjust C122, C125 and C128 at 100 kc/s and L57, L58 and L59 at 800 kc/s. Repeat as necessary until alignment is correct at both ends of the band. The input required for 100 μ A meter deflection should be between 5 and 10 μ V.

5.6 37.5 Mc/s FILTER AND AMPLIFIER

Remove the 1 Mc/s crystal, second mixer valve V9 and the first v.f.o. valve V5. Check that all the screening covers are in place. Connect a suitable valve voltmeter, shunted to 12pF, to TP3. Inject an accurate 37.5 Mc/s signal at TP1. Ensure the valve voltmeter and signal generator leads are short to avoid regeneration. Adjust L50, C90, C81, C72, C63, C55, C45, C35, C24, L28 and L33 in that order, several times, to obtain maximum output. The input required to produce 1V should be approximately 2.5mV. The 6dB bandwidth of the 37.5 Mc/s chain should lie between 229–300 kc/s. The bandwidth at 40dB should not exceed 750 kc/s. The mean of the frequencies corresponding to the 6dB points should not deviate from 37.5 Mc/s by more than 20 kc/s and by more than 25 kc/s at 40dB bandwidth.

C108 is adjusted to avoid interaction between the 37.5 and 40 Mc/s filters and should not normally require further adjustment. Replace the 1 Mc/s crystal, the second mixer and the first v.f.o. valve.

5.7 1 Mc/s CRYSTAL OSCILLATOR

Connect the valve voltmeter to the 1 Mc/s output plug PL2 and adjust L2 for maximum output (2–3V). C2 may be adjusted to 'pull' the crystal to the correct frequency. Adjustment of the crystal frequency should not be attempted unless a standard of accuracy better than one part in 10^7 is available.

5.8 SECOND MIXER DRIVE LEVEL

Remove the second mixer valve V9. Connect the valve voltmeter, shunted to 12pF, to TP3. Tune through each megacycle calibration point and check that the level of each output lies between 2 and 10V. To equalise the drive at 28 and 29 Mc/s carefully adjust C7.

5.9 FIRST V.F.O. CALIBRATION

Slacken off the mechanical end-stop until it is inoperative. Set C76 to maximum capacity and ensure that the calibration mark at the zero end of the MEGACYCLES dial coincides with the cursor. Tighten end-stop after moving the scale free from the stop. Check that the mechanical stops operate before the capacitor end-stops become effective at both ends of the band.

To readjust the first v.f.o. calibration, a heterodyne wavemeter should be employed. This is coupled very loosely to V7 by placing its input lead in the vicinity of the valve base. The 1 Mc/s crystal and V12 should be removed.

Set the wavemeter to 40.5 Mc/s and the MEGACYCLES dial to zero. Adjust L36 for zero-beat. Change the wavemeter setting to 69.5 Mc/s and the MEGACYCLES dial to 29. Adjust C77 for zero-beat. Repeat adjustment as necessary. Check the frequency calibration at 1 Mc/s intervals and ensure that the megacycle positions are reasonably central on the scale markings. Remove the first mixer valve V7 and connect the valve voltmeter, shunted to 12pF, between TP2 and the chassis. Check that the valve voltmeter indicates at least 1.5V over the range. Replace the 1 Mc/s crystal, V12 and V7.

5.10 AERIAL CIRCUIT

Remove the first v.f.o. valve V5 and the first mixer valve V7 and set the receiver controls as follows:—

- AE. ATTENUATOR to MIN.
- AE. RANGE Mc/s to 0.5 Mc/s
- System switch to MAN.
- I.F. GAIN to MAX.

Remove the screening cover from around C18A/B and connect a 1 kilohm resistor across the secondary section (C18B rear section). Set the AE. TUNE control to approximately $\frac{1}{4}$ ths of its travel in a clockwise direction.

Connect the valve voltmeter, shunted to 12pF, between TP2 and chassis. Connect the output of the signal generator to the aerial input socket. Set the generator for a frequency of 0.5 Mc/s.

Remove the top core from the transformer L9 and adjust the primary core for a maximum deflection in the valve voltmeter. (The position of this core should be such that it tunes at a point nearest the bottom of the transformer).

Remove the 1 kilohm resistor from the secondary section and connect it across the primary section of C18.

Refit top core (secondary) and adjust it for a maximum deflection in the valve voltmeter.

Remove the 1 kilohm resistor from the primary of C18.

Reset the signal generator frequency to 1 Mc/s and adjust the AE. TUNE control (C18) for maximum output in the valve voltmeter then adjust the trimmer capacitor C232 for a maximum deflection in the valve voltmeter also check for symmetrical response.

Repeat the above procedure for the AE. RANGE switch settings and frequencies listed below.

AE. RANGE	ALIGNMENT FREQUENCY		INDUCTANCE
	Primary	Secondary	
1-2	1 Mc/s	2 Mc/s	L8
2-4	2 Mc/s	4 Mc/s	L7
4-8	4 Mc/s	8 Mc/s	L6
8-16	8 Mc/s	16 Mc/s	L5
16-30	13 Mc/s	30 Mc/s	L4
	(C18 at max.)		

Maximum voltage input for 0.5 volt output.

AE. RANGE	L.F.	H.F.
0.5-1 Mc/s	6mV	6mV
1-2 Mc/s	7mV	7 mV
2-4 Mc/s	10mV	10mV
4-8 Mc/s	12mV	16mV
8-16 Mc/s	22mV	26mV
16-30 Mc/s	22mV	30mV

5.11 CRYSTAL CALIBRATOR

Should no output be obtained from this unit when the System switch is in the CAL position and the KILOCYCLES scale set at a 100 kc/s check point, or if spurious responses are obtained over the kilocycles range, proceed as follows:—

Set the KILOCYCLES scale to a 100 kc/s point and check the tuning of L70 by carefully rotating the core a half-turn either side of the setting. If the signal does not appear, restore the core to its original setting and repeat the check with L75. If the signal is heard, the cores of L70 and L75 should be set to the centre of the range of adjustment over which a clean signal is produced.

Should a major fault be suspected, or if L70 or L75 have been inadvertently misaligned, it will be necessary to remove the unit and make up an extension cable so that the unit may be operated outside the receiver. The crystal calibrator may be aligned as follows:—

Remove V13 and connect the valve voltmeter probe to grid 3 (Pin 7). Inject a 900 kc/s c.w. signal, from the signal generator, at the grid of V15 (Pin 1) and adjust L75 for maximum output. Disconnect the valve voltmeter and the signal generator, replace V13 and remove V15. Connect the signal generator to grid 1 (Pin 1) of V13 and the valve voltmeter to the grid 1 connection (Pin 1) of V15. Set the signal generator to 100 kc/s c.w. and adjust L70 for maximum indication on the valve voltmeter. Disconnect the valve voltmeter and the generator. Replace V15. Connect the coaxial connector to SK2 on the receiver.

The output should be approximately 0.2V measured between Pin 6 of the octal plug and earth.

5.12 40 Mc/s FILTER

This filter is over-coupled and cannot be readily aligned without a 40 Mc/s sweep oscillator. Readjustment therefore should not be attempted unless the specially designed test equipment and factory-type alignment jigs are available.

5.13 RECEIVER OVERALL GAIN TEST

Test Equipment required:

Audio power Meter similar to Marconi TF 893A
Signal Generator similar to Marconi TF 144H
Terminating Resistors various (see text).

Note: The signal generator used must have an output impedance of 75Ω . If this is not available a matching pad should be inserted between the signal generator and the receiver and the output voltage of the signal generator increased by a factor depending on the attenuation introduced by the matching pad in use.

To perform an overall gain (sensitivity) test proceed as follows:—

(1) Set the controls on the receiver as follows:—

AE. RANGE	2-4
MEGACYCLES	3
KILOCYCLES	500
AE. ATTENUATOR	Min.
System Switch	MAN
BANDWIDTH	3 Kc/s
B.F.O. Switch	ON
B.F.O. Note	1 Kc/s
I.F. GAIN	Fully clockwise

- (2) Set the controls of the output meter for 600Ω impedance and a range of 6mW. Connect the output meter across one of the 600Ω 3mW. windings and terminate the other windings with resistors to match their marked impedance.
- (3) Set the controls of the signal generator for a C.W. output of 1 microvolt at 3.5 Mc/s and an impedance of 75Ω . Connect the output of the signal generator to the aerial input of the receiver.
- (4) Tune the receiver to the output frequency of the signal generator and check that a reading of 3mW. can be obtained within the range of the A.F. GAIN control.
- (5) Repeat the test with the B.F.O. switched off and a 30% modulated signal at a level of 3.5 microvolts from the signal generator.

(9) The v.f.o. may now be withdrawn vertically. When servicing this assembly, clean the wormwheel and the split gear on the ganged capacitor shaft with carbontetrachloride, then apply with a brush, to the wormwheel only (illustration 6), a thin coating of Molybdenum Disulphide grease (Rocol "Molypad").

(a) Removal of Kilocycles film scale:—

- (i) Rotate the KILOCYCLES knob to the 1000 KC/S end stop.
- (ii) Remove the front panel:—see 1 above.
- (iii) While firmly holding the two gears situated above the film bobbins, remove the plate carrying the fibre idler gear.
- (iv) Allow the two gears to unwind slowly.
- (v) Unwind the film scale.

(b) To fit a new film scale:—

- (i) Pass the 1000 KC/S end round the drive sprocket and wrap the end round the split pin on the inner bobbin; rotate this bobbin until most of the film scale is wound.
- (ii) Wrap the other end of the film scale round the split pin on the other bobbin, and rotate the bobbin counter-clockwise until the film scale is taut.
- (iii) Wind the gears in opposite directions for $\frac{3}{4}$ to 1 turn, and while holding the gears under tension re-engage the idler gear.
- (iv) Secure the plate by the two fixing screws.
- (v) To check calibration, see second v.f.o. alignment procedure (Section 5.3).

(c) Ganged Capacitor

Note: Refer to the second v.f.o. alignment procedure (Section 5.3) before attempting to replace the ganged capacitor.

- (i) Remove the second v.f.o. from the receiver in accordance with the instructions above.
- (ii) Remove the KILOCYCLES scale.
- (iii) Unscrew the remaining cover plate and the under chassis screen.
- (iv) Unsolder the capacitor connections.
- (v) Remove the drive gear and collet.
- (vi) Unscrew the three fixing screws holding the capacitor to the bracket; ensure that the anti-backlash gears are loaded.

3. First Variable Frequency Oscillator

- (1) Remove the front panel, the bottom cover and the screens from compartments 3, 8 and 13. (See illustration 1: Key to Under-Chassis Layout).
- (2) Unsolder the connecting wires from the two turret lugs situated in compartment 3, the leads to the turret lug in compartment 8, the pin connections in compartment 5 and the screened cable in compartment 13.
- (3) Unscrew the three fixing screws on the top of the unit.

(a) To fit a new chain:—

- (i) Take a 63-link length of chain.
- (ii) Hold chain tension sprocket down towards the chassis, and fit new chain round the two chain wheels.
- (iii) Release the tension sprocket ensuring that it holds the chain under tension. See Front Panel instructions regarding refitting of B.F.O. NOTE control knob: Section 6.2.

4. 100 Kc/s I.F. Strip

- (1) Remove the left-hand gusset plate adjacent to the unit.
- (2) Unsolder the leads to the 4 and 12-way tag strips and the 100 KC/S OUTPUT plugs.
- (3) Disconnect the coaxial lead to the second v.f.o.
- (4) Remove the six screws securing this unit to the main chassis.

Note: Removal of the I.F. GAIN control on the b.f.o. assembly is necessary in order to obtain access to one of the six securing screws.

(a) Beat Frequency Oscillator

- (i) Remove Front Panel.
- (ii) Remove bottom cover.
- (iii) Disconnect leads from I.F. GAIN potentiometer.
- (iv) Remove side plates adjacent to i.f. strip.
- (v) Remove screw securing cable cleat situated adjacent to 150mH choke assembly on underside of i.f. strip.
- (vi) Disconnect red-white lead of b.f.o. cableform from terminal on adjacent 12-way tag strip.
- (vii) Withdraw red-white lead from cableform.
- (viii) Disconnect brown leads from pin 4 of V18 socket.
- (ix) Disconnect yellow leads from pin 7 of V21 socket.
- (x) Remove remaining three 6 B.A. screws and crinkle washers to release b.f.o. assembly from i.f. strip chassis.

6.3 VALVE REPLACEMENT

With the exception of V5, replacement of valves will not affect receiver alignment. When V5 is replaced refer to Part 1, Section 5.

SECTION 7
ILLUSTRATIONS

	<i>Illustration</i>
Key to Under-Chassis Layout	1
Chassis Assembly, Top	2
Chassis Assembly, Underside	3
Crystal Oscillator and Harmonic Filter System, Underside	4
First V.F.O. Unit, Underside	5
Second V.F.O. Unit, Front	6
Second V.F.O. Unit, Rear	7
Second V.F.O. Unit, Underside	8
100 kc/s I.F. Strip, Right Side	9
100 kc/s I.F. Strip, Left Side	10
B.F.O. Unit, Underside	11
Crystal Calibrator Unit, Underside	12

ILLUSTRATION 1

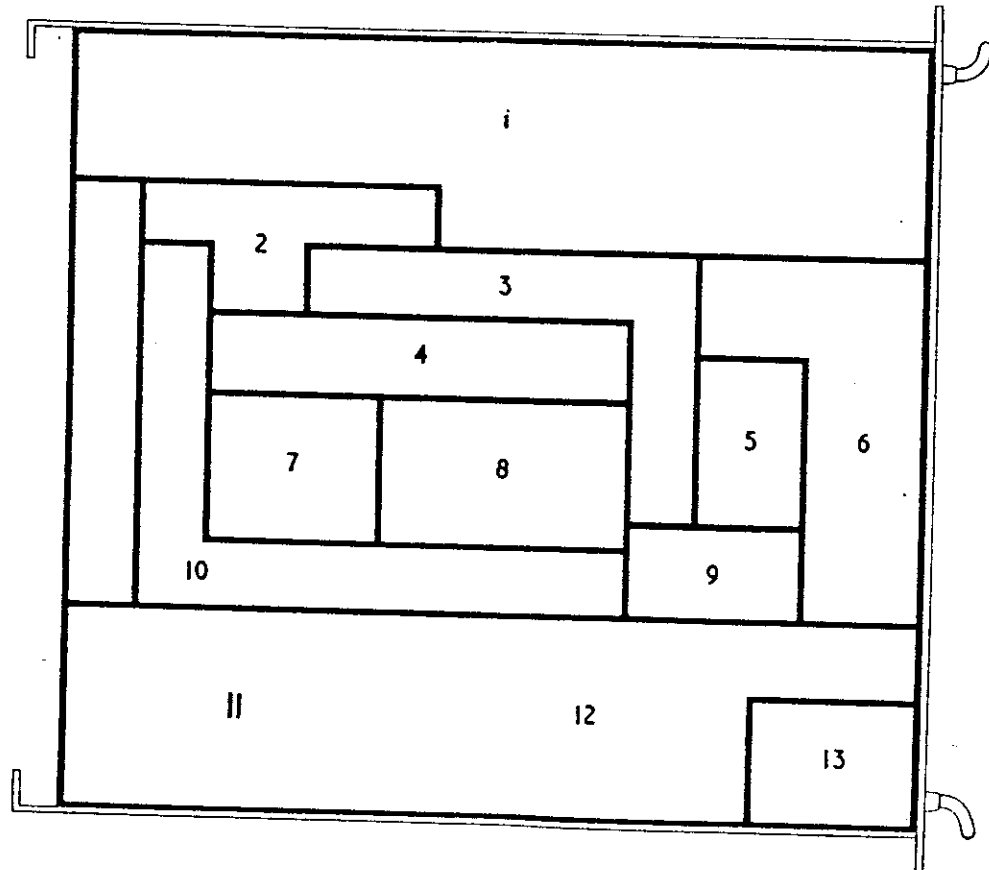

- 1 100kc/s IF
- 2 SECOND MIXER
- 3 40Mc/s. IF
- 4 HARMONIC FILTER
- 5 FIRST VFO SUPPLY FILTER
- 6 SYSTEM COMPARTMENT
- 7 CRYSTAL OSCILLATOR AND HARMONIC GENERATOR
- 8 HARMONIC MIXER AND 37.5Mc/s. AMPLIFIER
- 9 SUPPLY FILTER FOR 7 & 8
- 10 37.5Mc/s BAND PASS FILTER
- 11 POWER SUPPLIES
- 12 AUDIO STAGES
- 13 AERIAL ATTENUATOR

KEY TO UNDER-CHASSIS LAYOUT

ILLUSTRATION 2

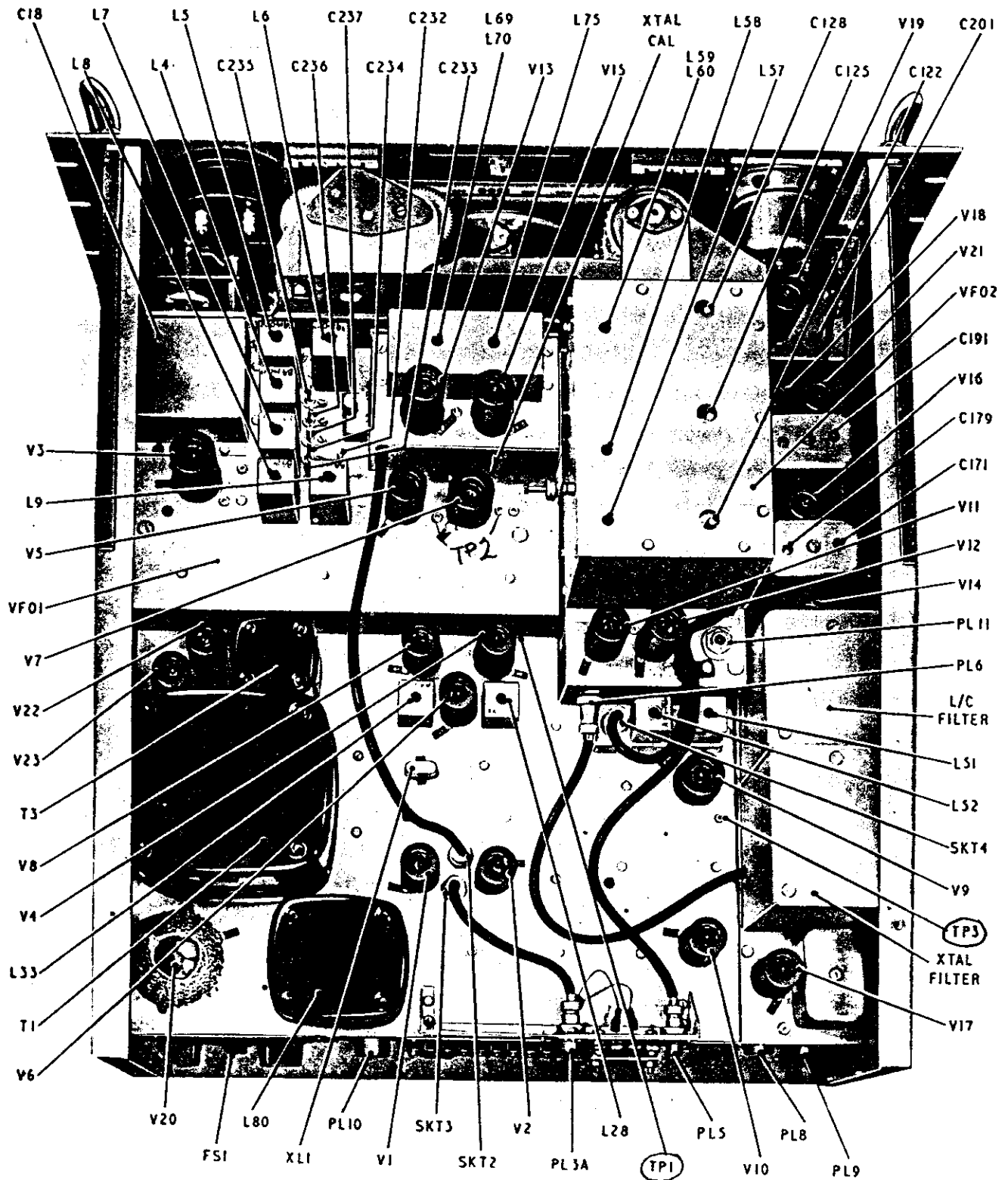

CHASSIS ASSEMBLY (TOP)

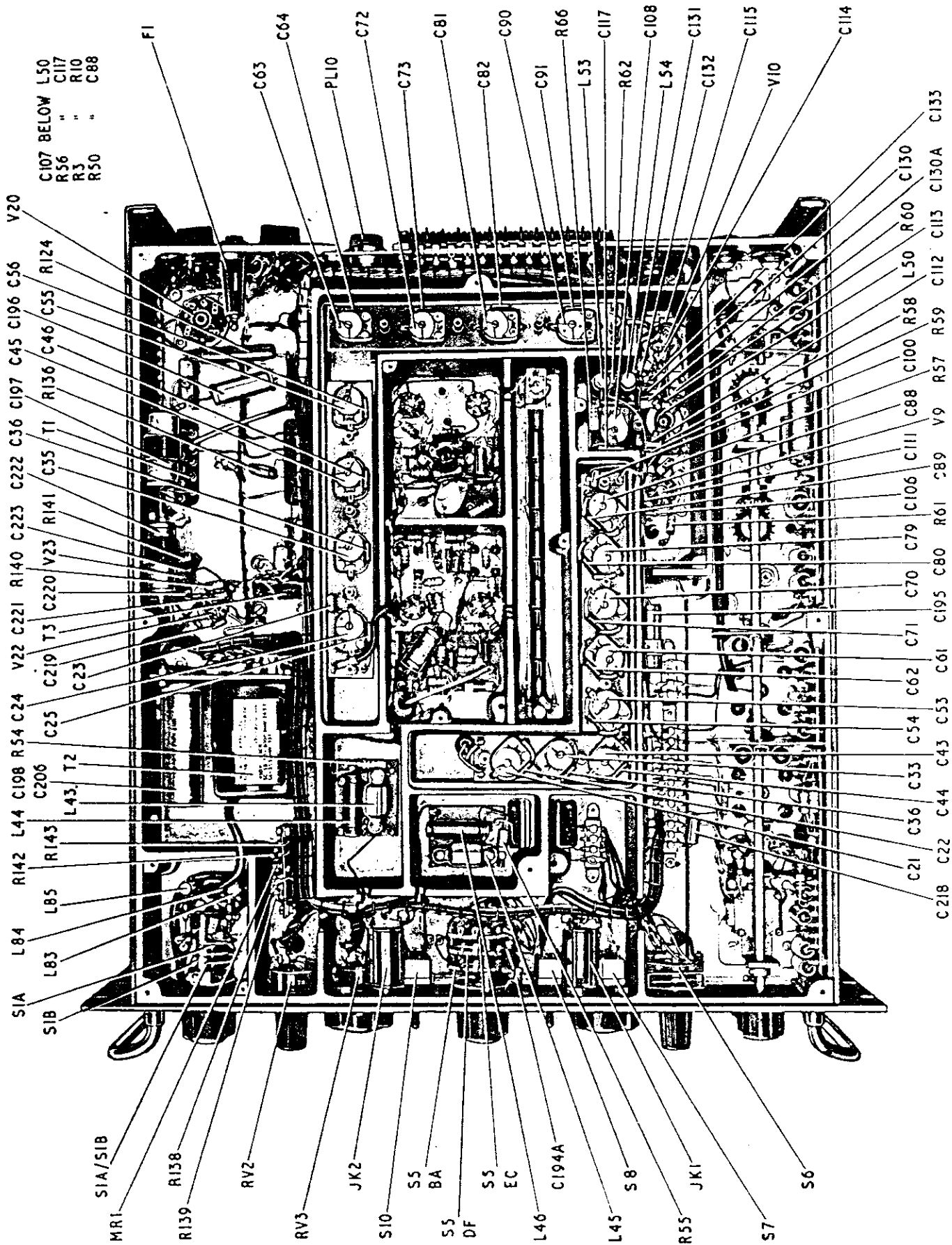

CHASSIS ASSEMBLY (UNDERSIDE)

ILLUSTRATION 4

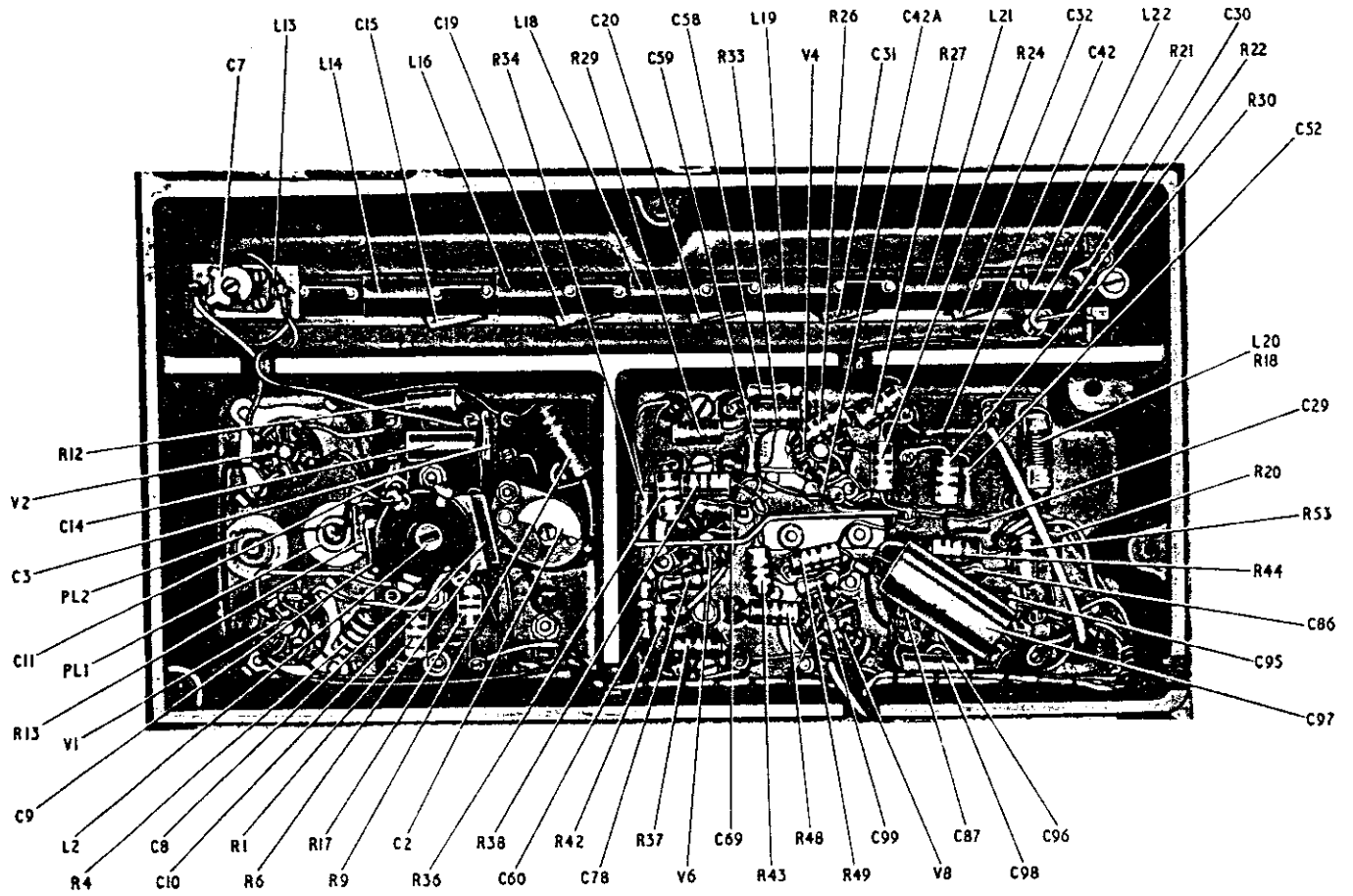

CRYSTAL OSCILLATOR AND HARMONIC FILTER SYSTEM (UNDERSIDE)

ILLUSTRATION 5

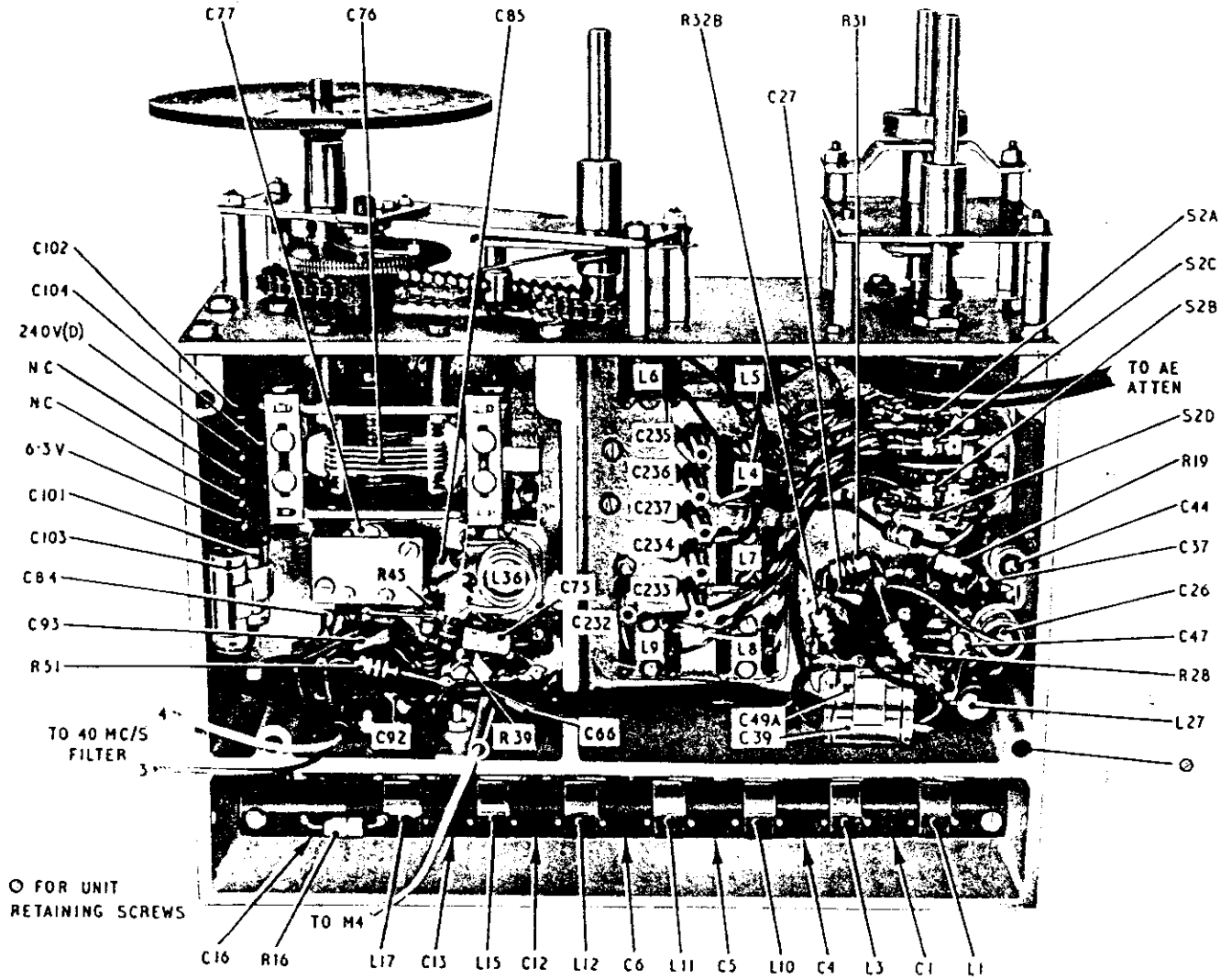

FIRST VFO UNIT (UNDERSIDE)

ILLUSTRATION 6

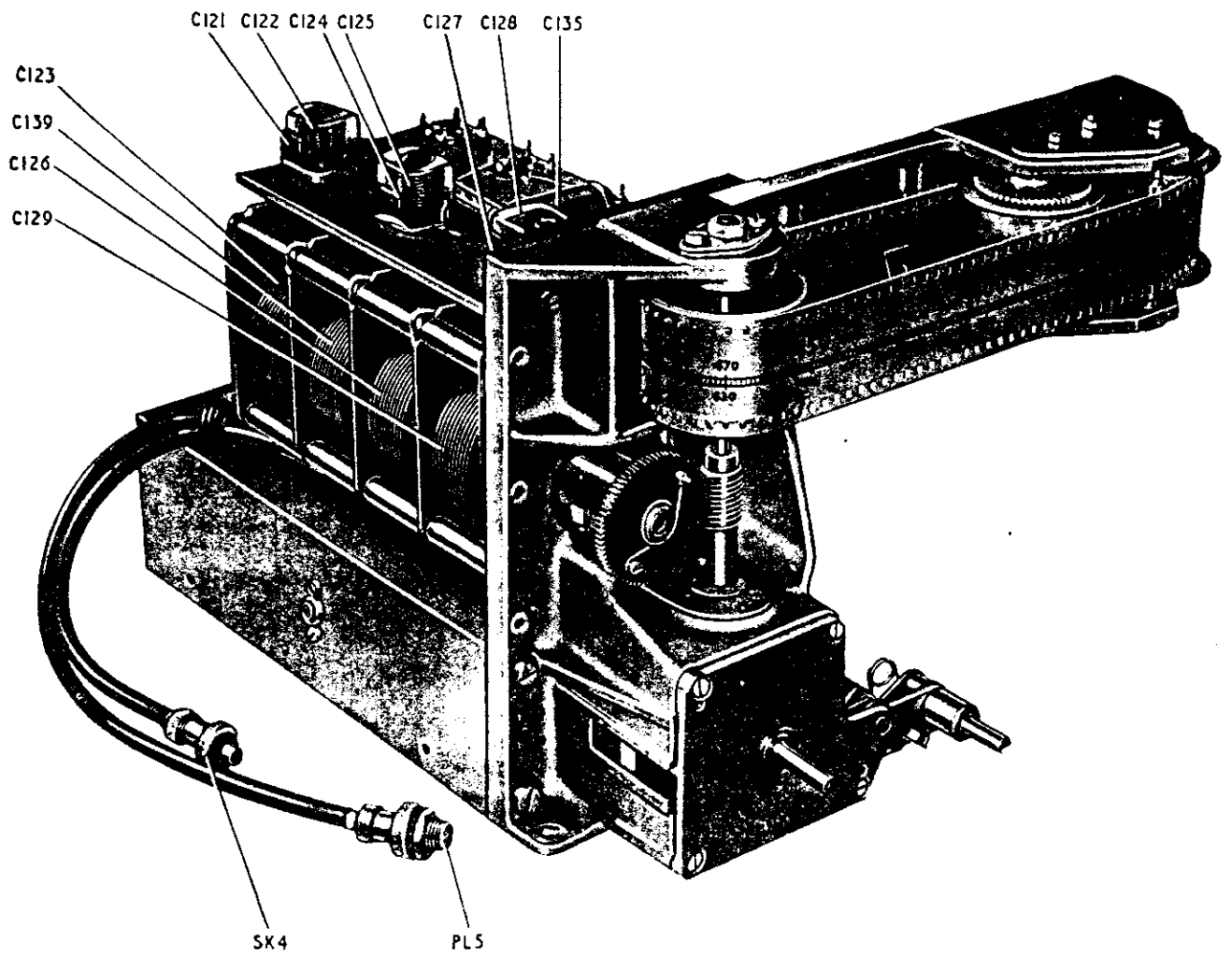

SECOND VFO UNIT (FRONT)

ILLUSTRATION 7

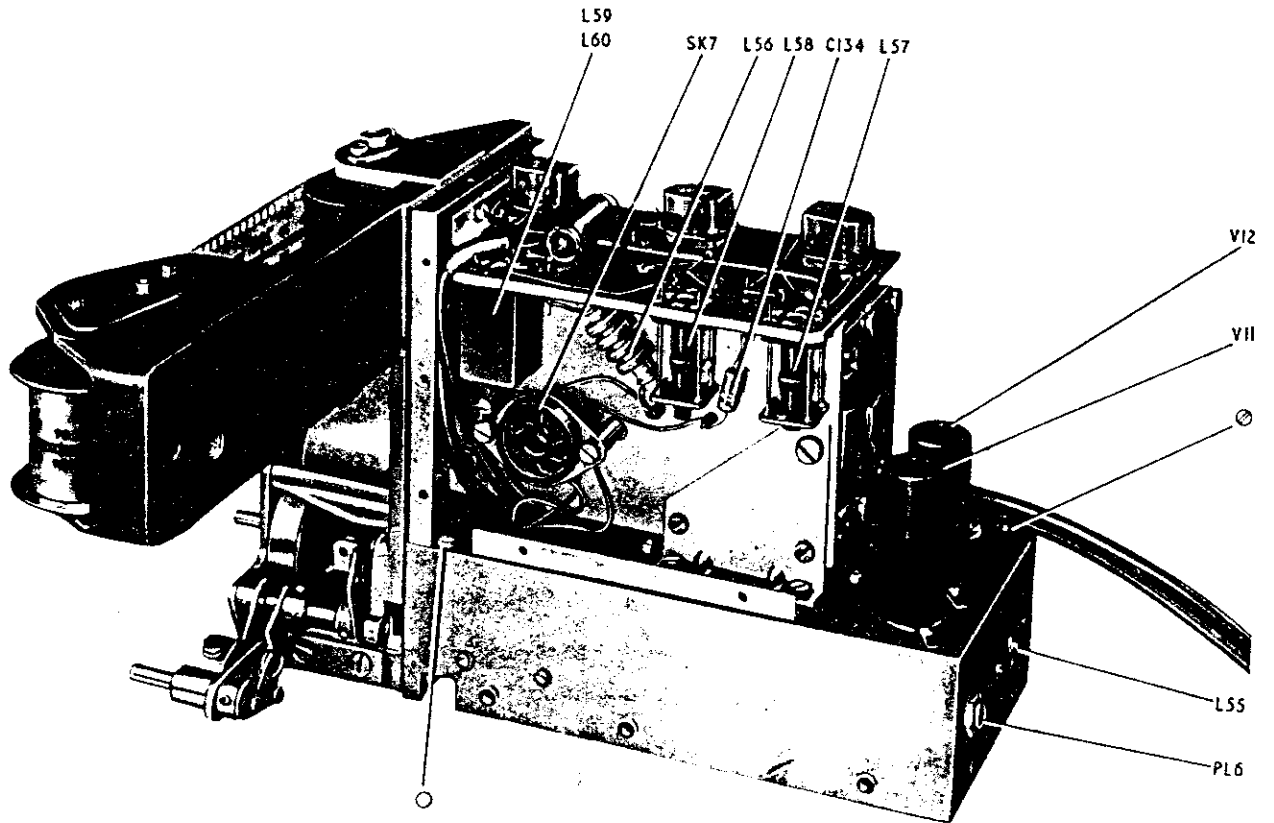

○ UNIT RETAINING SCREWS

SECOND VFO UNIT (REAR)

ILLUSTRATION 8

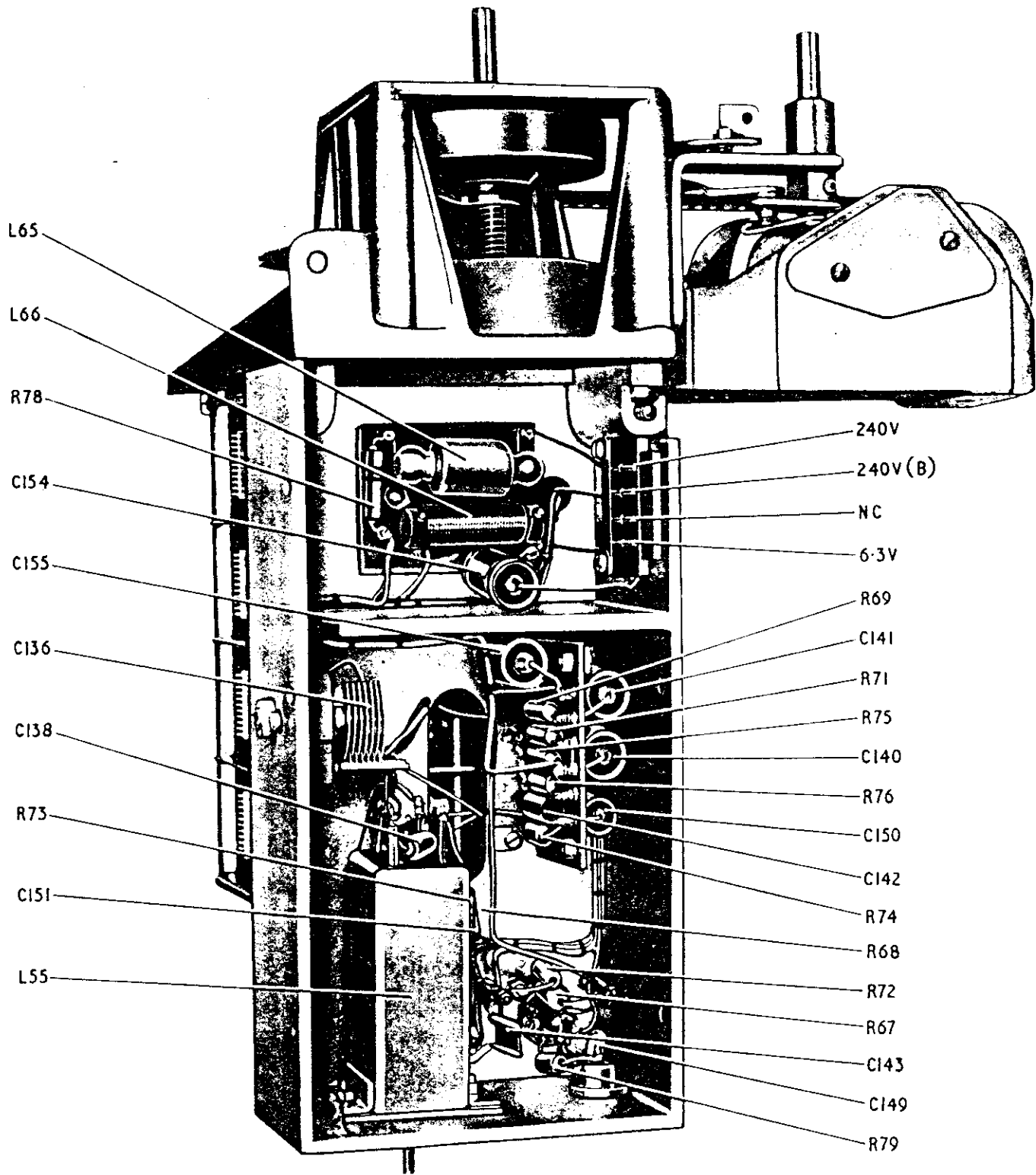

SECOND VFO UNIT (UNDERSIDE)

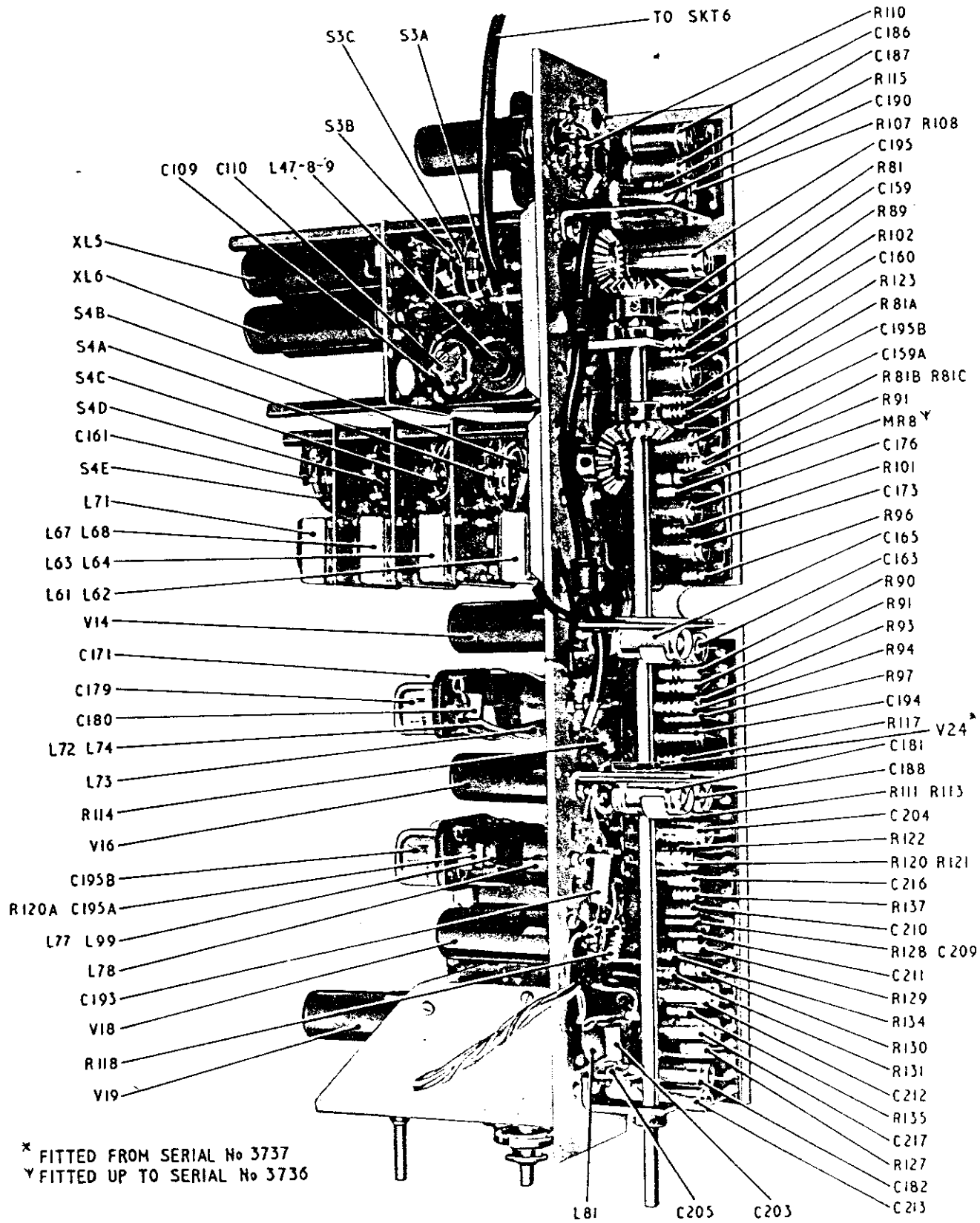

* FITTED FROM SERIAL No 3737
 Y FITTED UP TO SERIAL No 3736

100 kc/s I.F. STRIP (RIGHT SIDE)

ILLUSTRATION 10

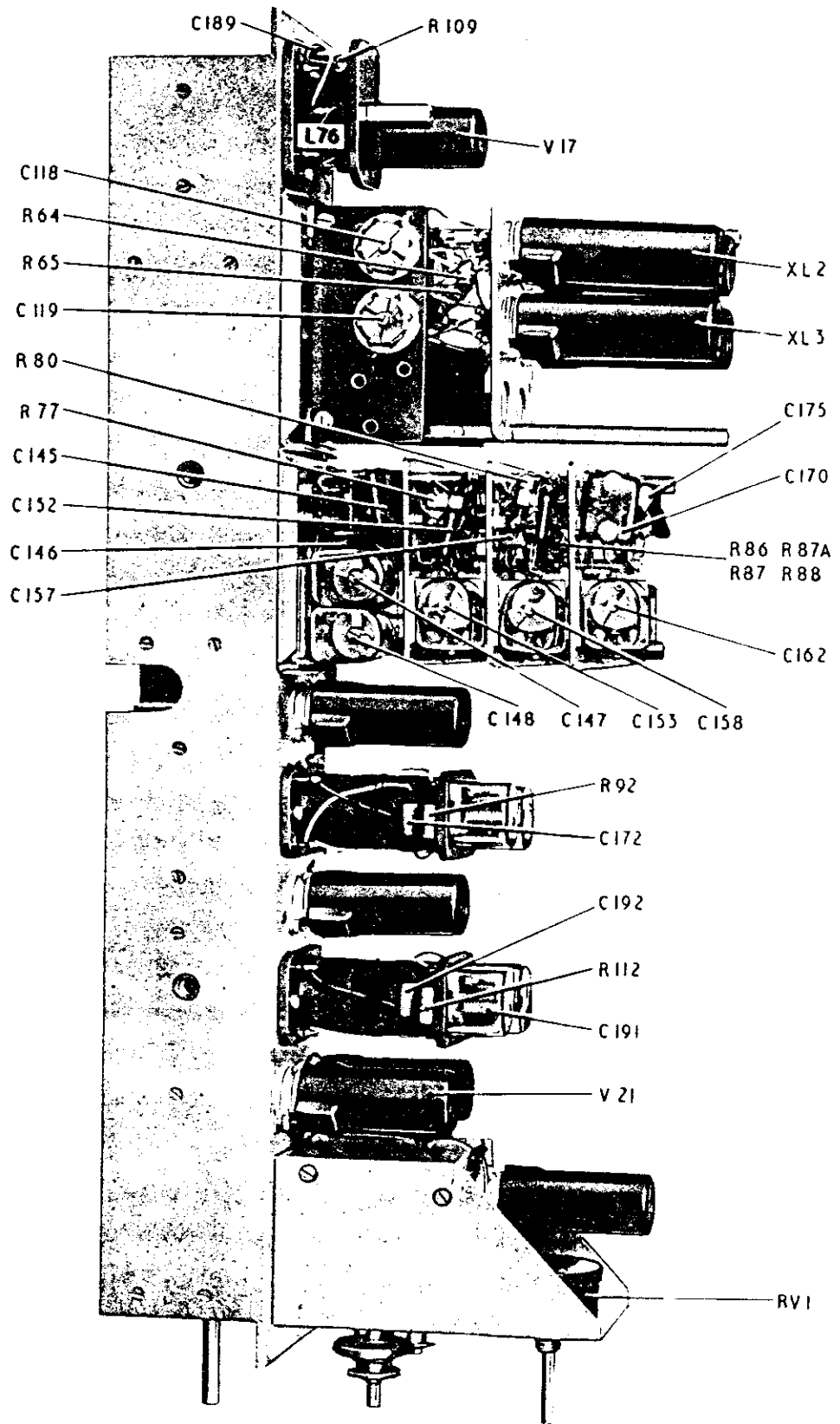

100 KC/S I.F. STRIP (LEFT SIDE)

ILLUSTRATION 11

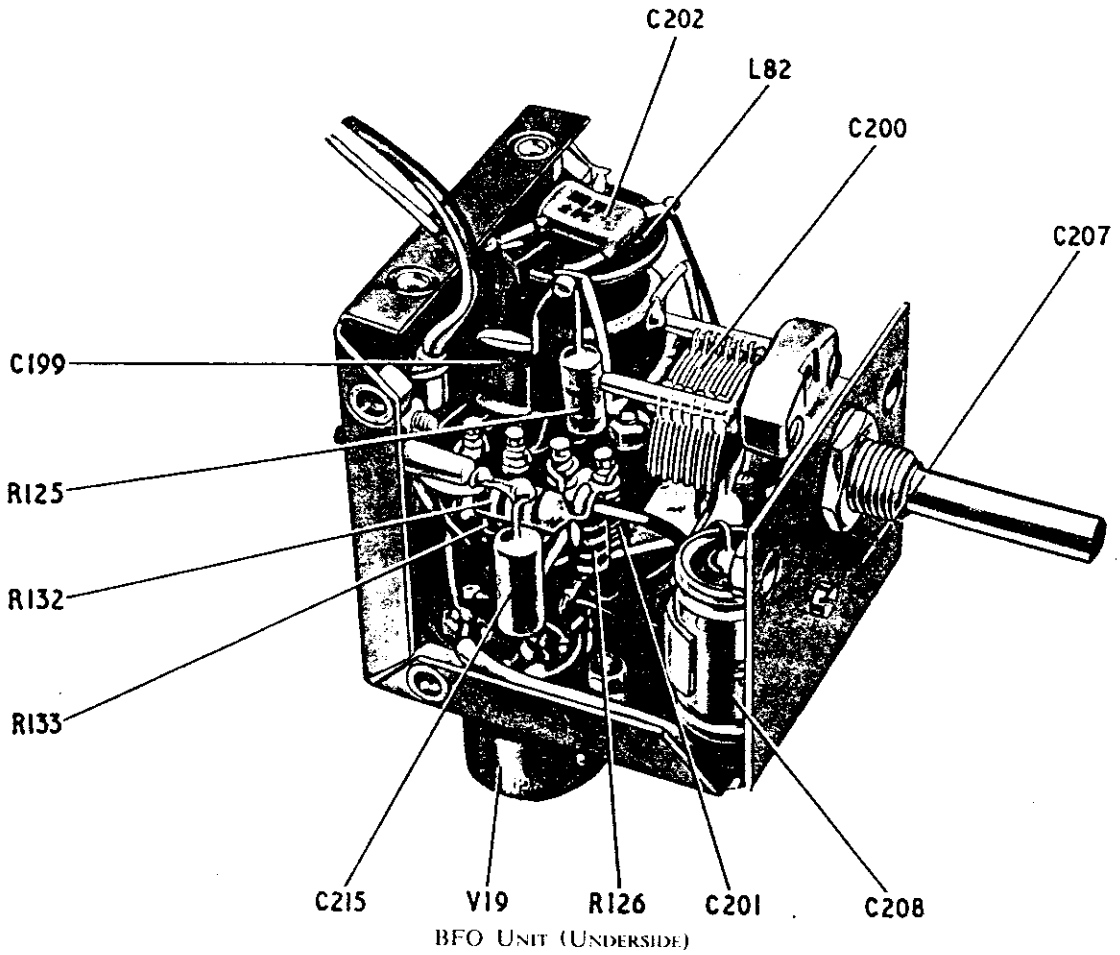

BFO UNIT (UNDERSIDE)

ILLUSTRATION 12

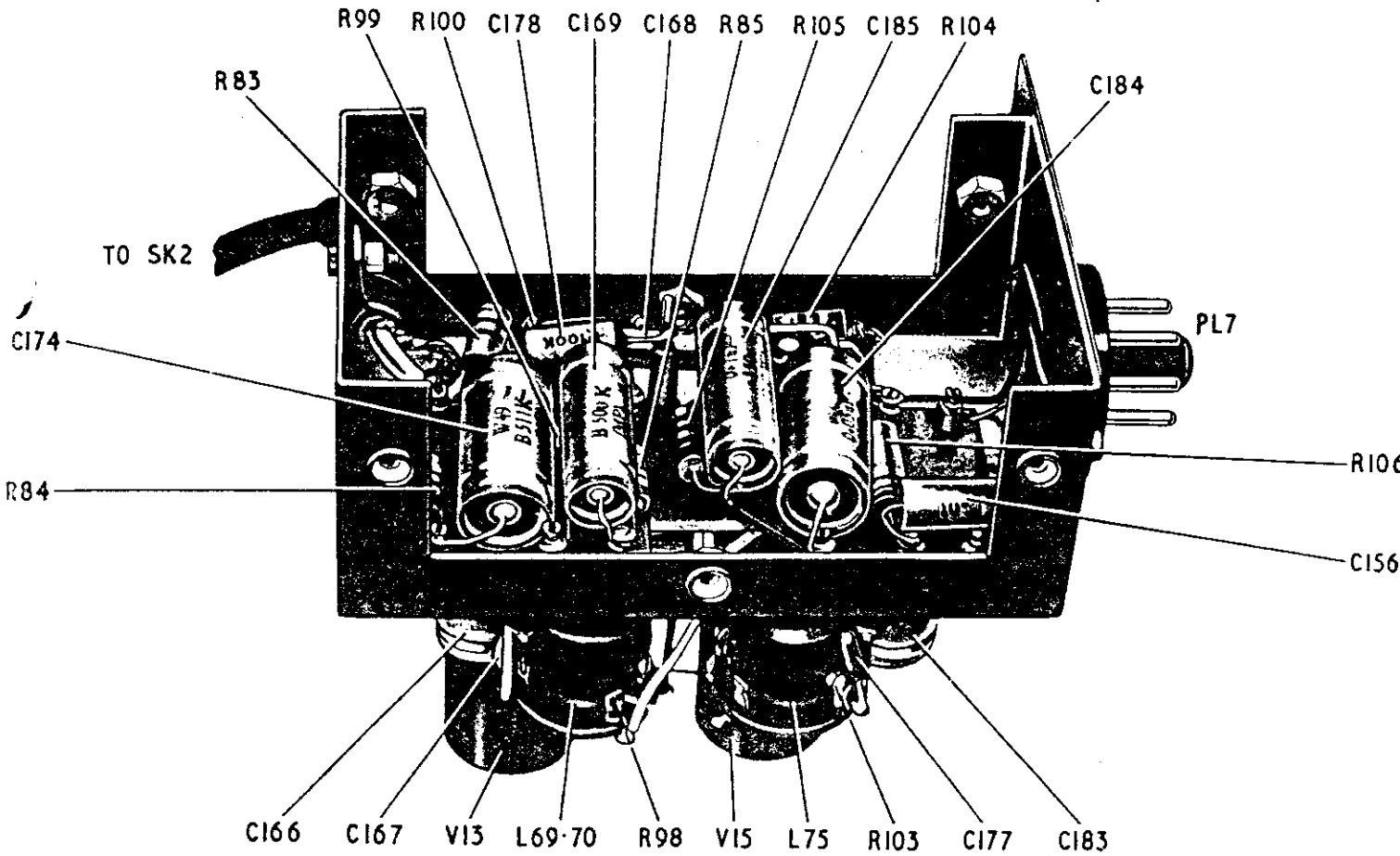

CRYSTAL CALIBRATOR UNIT (UNDERSIDE)

SECTION 8

LIST OF CIRCUIT COMPONENTS, SUPPLEMENTARY COMPONENTS, SUB-ASSEMBLIES AND SUB-UNITS

- 8.1 Resistors
- 8.2 Potentiometers
- 8.3 Capacitors
- 8.4 Switches
- 8.5 Plugs and Sockets
- 8.6 Valves (British)
- 8.7 Valves (American)
- 8.8 Valve and Crystal Holders
- 8.9 Inductances
- 8.10 Transformers
- 8.11 Rectifier
- 8.12 Loudspeakers
- 8.13 Meters
- 8.14 Crystals
- 8.15 Fuses and Fuseholders
- 8.16 Lamp and Holder
- 8.17 Voltage Selectors
- 8.18 Supplementary Components,
and Sub-Assemblies
- 8.19 Main Sub-Units

Joint-Service Numbers

(also known as CCA or NATO Stock Numbers)

Commercial and private users will note that the above numbers have been included in this section ; these are for assisting Service users in the provisioning of spare components.

Note: It is recommended that users quote the Serial No. of the equipment on all orders for spare parts.

* Indicates component used in RA.17L Receivers only.

† Indicates component used in RA.17C-12 Receivers only.

8.1 RESISTORS

<i>Cct. Ref.</i>	<i>Value</i>	<i>Description</i>	<i>Rating</i>	<i>Tol.</i>	<i>Joint Service No.</i>	<i>Manufacturer and Type or Drawing No.</i>	
R1	100kΩ	Carbon	½W	10%	5905-99-022-3037	Eric	16
R2	100Ω	Carbon	½W	10%	022-1109	"	16
R3	150Ω	Carbon	½W	10%	022-1130	"	16
R4	100Ω	Carbon	½W	10%	022-1109	"	16
R5	150Ω	Carbon	½W	10%	022-1130	"	16
R6	4.7kΩ	Carbon	½W	10%	022-2090	"	8
R7	150Ω	Carbon	½W	10%	022-1130	"	16
R8	150Ω	Carbon	½W	10%	022-1130	"	16
R9	10kΩ	Carbon	½W	10%	022-2132	"	8
R10	150Ω	Carbon	½W	10%	022-1130	"	16
R11	150Ω	Carbon	½W	10%	022-1130	"	16
R12	100kΩ	Carbon	½W	10%	022-3037	"	16
R13	22kΩ	Carbon	½W	10%	022-2172	"	16
R14	150Ω	Carbon	½W	10%	022-1130	"	16
R15	100Ω	Carbon	½W	10%	022-1109	"	16
R15A	75Ω	Carbon	½W	10%	022-3038	"	9
R16	680Ω	Carbon	½W	10%	022-1214	"	16
R17	1kΩ	Carbon	½W	10%	022-2006	"	8
R18	470Ω	Carbon	½W	10%	022-1195	"	8
	(Assy. with L20)						
R19	270kΩ	Carbon	½W	10%	022-3091	"	16
R20	1kΩ	Carbon	½W	10%	022-2004	"	16
R21	330Ω	Carbon	½W	10%	022-1172	"	16
R22*	180Ω	Carbon	½W	10%	022-1142	"	16
R22†	470Ω	Carbon	½W	10%	022-1193	"	16
R23	82Ω	Carbon	½W	10%	022-1100	"	16
R24	10kΩ	Carbon	½W	10%	022-2130	"	16
R25	10Ω	Carbon	½W	10%	022-1001	"	16
R26	10Ω	Carbon	½W	10%	022-1001	"	16
R27	10Ω	Carbon	½W	10%	022-1001	"	16
R28	680Ω	Carbon	½W	10%	022-1214	"	16
R29*	1kΩ	Carbon	½W	10%	022-2004	"	16
R29†	4.7kΩ	Carbon	½W	10%	022-2088	"	16
R30	220Ω	Carbon	½W	10%	022-1151	"	16
R31	470Ω	Carbon	½W	10%	022-1193	"	16
R32	100kΩ	Carbon	½W	10%	022-3037	"	16
R32A	100kΩ	Carbon	½W	10%	022-3037	"	16
R32B	10kΩ	Carbon	½W	10%	022-2130	"	16
R33	10kΩ	Carbon	½W	10%	022-2130	"	16
R34	470kΩ	Carbon	½W	10%	022-3121	"	16
R35	DELETED					"	16
R36	10Ω	Carbon	½W	10%	022-1001	"	16
R37	1kΩ	Carbon	½W	10%	022-2004	"	16
R38*	220Ω	Carbon	½W	10%	022-1151	"	16
R38†	120Ω	Carbon	½W	10%	022-1121	"	16
R39*	1kΩ	Carbon	½W	10%	022-2004	"	16
R39†	18kΩ	Carbon	½W	10%	022-2163	"	16
R40	10Ω	Carbon	½W	10%	022-1001	"	16
R41*	47kΩ	Carbon	½W	10%	022-2214	"	16
R41†	10kΩ	Carbon	½W	10%	022-2130	"	16
R42	47kΩ	Carbon	½W	10%	022-2214	"	16
R43*	2.2kΩ	Carbon	½W	10%	022-2046	"	16
R43†	470kΩ	Carbon	½W	10%	022-3121	"	16

8.1 RESISTORS (continued)

<i>Cct. Ref.</i>	<i>Value</i>	<i>Description</i>	<i>Rating</i>	<i>Tol.</i>	<i>Joint Service No.</i>	<i>Manufacturer and Type or Drawing No.</i>	
R44*	10kΩ	Carbon	½W	10%	5905-99-022-2130	Erie	16
R44†	47kΩ	Carbon	½W	10%	022-2214	"	16
R45	10Ω	Carbon	½W	10%	022-1001	"	16
R46	100kΩ	Carbon	½W	10%	022-3037	"	16
R47	56Ω	Carbon	½W	10%	022-1079	"	16
R48	10Ω	Carbon	½W	10%	022-1001	"	16
R49*	220Ω	Carbon	½W	10%	022-1151	"	16
R49†	120Ω	Carbon	½W	10%	022-1121	"	16
R50	2·2kΩ	Carbon	½W	10%	022-2046	"	16
R51	1kΩ	Carbon	½W	10%	022-2004	"	16
R52	15kΩ	Carbon	½W	10%	022-2151	"	16
R53	470Ω	Carbon	½W	10%	022-1193	"	16
R54	100Ω	Carbon	½W	10%	022-1111	"	8
R55	1kΩ	Carbon	½W	10%	022-2006	"	8
R56	15kΩ	Carbon	½W	10%	022-2151	"	16
R57	10Ω	Carbon	½W	10%	022-1001	"	16
R58	470kΩ	Carbon	½W	10%	022-3121	"	16
R59	56Ω	Carbon	½W	10%	022-1079	"	16
R60*	220Ω	Carbon	½W	10%	022-1151	"	16
R60†	120Ω	Carbon	½W	10%	022-1121	"	16
R61	470Ω	Carbon	½W	10%	022-1193	"	16
R62*	10kΩ	Carbon	½W	10%	022-2130	"	16
R62†	47kΩ	Carbon	½W	10%	022-2214	"	16
R63	DELETED						
R64	330kΩ	Carbon	½W	10%	022-3100	"	16
R65	100kΩ	Carbon	½W	10%	022-3037	"	16
R66	1kΩ	Carbon	½W	10%	022-2006	"	8
R67	470Ω	Carbon	½W	10%	022-1193	"	16
R68	22kΩ	Carbon	½W	10%	022-2172	"	16
R69	18kΩ	Carbon	½W	10%	022-2165	"	8
R70*	470kΩ	Carbon	½W	10%	022-3121	"	16
R70†	82kΩ	Carbon	½W	10%	022-3028	"	16
R71	12kΩ	Wirewound	3W	5%	011-3346	Painton	P306
R72	470Ω	Carbon	½W	10%	022-1193	Erie	16
R73	470Ω	Carbon	½W	10%	022-1193	"	16
R74	150Ω	Carbon	½W	10%	022-1130	"	16
R75	8·2kΩ	Carbon	½W	10%	022-2123	"	8
R76*	33kΩ	Carbon	½W	10%	022-2195	"	8
	(Fitted up to Ser. No. 3736)						
R76†	DELETED						
R76A*	82kΩ	Carbon	½W	10%	022-3028	"	16
R76A†	47kΩ	Carbon	½W	10%	022-2214	"	16
R77	470Ω	Carbon	½W	10%	022-1193	"	16
R78	1kΩ	Carbon	½W	10%	022-2006	"	8
R79	2·2kΩ	Carbon	½W	10%	022-2047	"	8
R80	470kΩ	Carbon	½W	10%	022-3121	"	16
R81	2·2kΩ	Carbon	½W	10%	022-2048	"	8
R81A	1·5kΩ	Carbon	½W	10%	022-2025	"	16
R81B	10mΩ	Carbon	½W	10%	022-3289	"	16
R81C	10mΩ	Carbon	½W	10%	022-3289	"	16
R82	DELETED						
R83	4·7kΩ	Carbon	½W	10%	022-2088	"	16
R84	1MΩ	Carbon	½W	10%	022-3163	"	16
R85	220Ω	Carbon	½W	10%	022-1151	"	16
R86	22Ω	Carbon	½W	10%	022-1025	"	16
R87	120Ω	Carbon	½W	10%	022-1121	"	16
R87A	68Ω	Carbon	½W	10%	022-1088	"	16
R88	330Ω	Carbon	½W	10%	022-1172	"	16
R89	2·2kΩ	Carbon	½W	10%	022-2048	"	8

8.1 RESISTORS (continued)

Cct. Ref.	Value	Description	Rating	Tol.	Joint Service No.	Manufacturer and Type or Drawing No.	
R90	4.7kΩ	Carbon	½W	10%	5905-99-022-2090	Erie	8
R91	4.7kΩ	Carbon	½W	10%	022-2090	"	8
R91A	470kΩ	Carbon	½W	10%	022-3121	"	16
R92	270kΩ	Carbon	½W	10%	022-3091	"	16
R93	33kΩ	Carbon	½W	10%	022-2195	"	8
R94	27kΩ	Carbon	½W	10%	022-2186	"	8
R95	100Ω	Carbon	½W	10%	022-1109	"	16
R96	470kΩ	Carbon	½W	10%	022-3121	"	16
R97	15kΩ	Carbon	½W	10%	022-2153	"	8
R97A*	39kΩ	Carbon	½W	10%	022-2205	"	16
		(Fitted from Ser. No. 3737)					
R97A†	39kΩ	Carbon	½W	10%	022-2205	"	16
R98	2.2kΩ	Carbon	½W	10%	022-2046	"	16
R99	22kΩ	Carbon	½W	10%	022-2172	"	16
R100	22kΩ	Carbon	½W	10%	022-2172	"	16
R101	120Ω	Carbon	½W	10%	022-1121	"	16
R102	82kΩ	Carbon	½W	10%	022-3028	"	16
R103	2.2kΩ	Carbon	½W	10%	022-2046	"	16
R104	1MΩ	Carbon	½W	10%	022-3163	"	16
R105	1kΩ	Carbon	½W	10%	022-2004	"	16
R106	68kΩ	Carbon	½W	10%	022-3018	"	8
R107	2.2kΩ	Carbon	½W	10%	022-2048	"	8
R108	33kΩ	Carbon	½W	10%	022-2195	"	8
R109	4.7kΩ	Carbon	½W	10%	022-2090	"	8
R110	100Ω	Carbon	½W	10%	022-1109	"	16
R111	2.2kΩ	Carbon	½W	10%	022-2048	"	8
R112	47kΩ	Carbon	½W	10%	022-2214	"	16
R113	33kΩ	Carbon	½W	10%	022-2195	"	8
R114	100Ω	Carbon	½W	10%	022-1109	"	16
R115	150Ω	Carbon	½W	10%	022-1130	"	16
R116	470kΩ	Carbon	½W	10%	022-1130	"	16
R116A†	5.6kΩ	Carbon	½W	10%	022-3121	"	16
R117	150Ω	Carbon	½W	±1%		Dubilier	R411
R118	2.2MΩ	Carbon	½W	10%	022-1130	Erie	16
R119	470kΩ	Carbon	½W	10%	022-3205	"	16
R119A	10kΩ	Wirewound	10W	5%	022-3121	"	16
R120	100kΩ	Carbon	½W	10%	011-3088	Zenith	TG214
R120A	27kΩ	Carbon	½W	10%	022-3039	Erie	8
R121	100kΩ	Carbon	½W	10%	022-2184	"	16
R122	6.8kΩ	Carbon	½W	10%	022-3039	"	8
R123	82kΩ	Carbon	½W	10%	022-2109	"	16
R124	165Ω	Wirewound	10W	5%	022-3030	"	16
R125	47kΩ	Carbon	½W	10%	972-8311	"	16
R126	100Ω	Carbon	½W	10%	022-2214	"	Style X
R127	82kΩ	Carbon	½W	10%	022-1109	"	16
R128	18kΩ	Carbon	½W	10%	022-3028	"	16
R129	18kΩ	Carbon	½W	10%	022-2163	"	16
R130	82kΩ	Carbon	½W	10%	022-2163	"	16
R131	4.7kΩ	Carbon	½W	10%	022-3028	"	16
R132	1kΩ	Carbon	½W	10%	022-2088	"	16
R133	4.7kΩ	Carbon	½W	10%	022-2004	"	16
R133A†	27kΩ	Carbon	½W	10%	022-2090	"	8
R134	1MΩ	Carbon	½W	10%	022-2184	"	16
R135	1.2MΩ	Carbon	½W	10%	022-3163	"	16
R135A†	100kΩ	Carbon	½W	10%	022-3175	"	16
R136	47Ω	Wirewound	3W	5%	022-3037	"	16
R136A	8.2kΩ	Carbon	½W	10%	011-3288	Welwyn	AW3115
R137	1.5MΩ	Carbon	½W	10%	022-2123	Erie	8
R137A*	100kΩ	Carbon	½W	10%	022-3184	"	16
R137B*	100kΩ	Carbon	½W	10%	022-3037	"	16
					022-3037	"	16

8.1 RESISTORS (continued)

<i>Cct. Ref.</i>	<i>Value</i>	<i>Description</i>	<i>Rating</i>	<i>Tol.</i>	<i>Joint Service No.</i>	<i>Manufacturer and Type or Drawing No.</i>	
R138	120Ω	Carbon	½W	5%	5905-99-	Erie	109
R138A†	100kΩ	Carbon	½W	10%	022-3039	"	8
R138B†	1.5kΩ	Carbon	3W	5%		Painton	P.306
R139	120Ω	Carbon	½W	5%		Erie	109
R139A†	470kΩ	Carbon	½W	10%	022-3121	"	16
R140*	220Ω	Carbon	½W	10%	022-1151	"	16
R140†	270Ω	Carbon	½W	10%		"	8
R140A†	4.7kΩ	Carbon	½W	10%	022-2088	"	16
R140B†	2.2kΩ	Carbon	½W	10%	022-2046	"	16
R141*	220Ω	Carbon	½W	10%	022-1151	"	16
R141†	680Ω	Carbon	½W	10%	022-1214	"	16
R142	1.2kΩ	Carbon	½W	5%		"	109
R143	1.2kΩ	Carbon	½W	5%		"	109
R144*	10Ω	Carbon	½W	10%	022-1001	"	16
R144†	DELETED						
R144A†	10Ω	Carbon	½W	10%	022-1001	"	16
R145	56kΩ	Carbon	½W	10%	022-3007	"	16

8.2 POTENTIOMETERS

RV1	1kΩ	Wirewound			5905-99-972-8314	Colvern	CLR3001/21
RV2	2MΩ	Composition log/law 1" spindle			940-9134	AB Metals Clarostat	37
RV3	2MΩ	Composition log/law ¾" spindle, slotted			940-9135	AB Metals Clarostat	37
RV4†	1kΩ	Wirewound				Colvern	CLR1189/15S

8.3 CAPACITORS

C1	2.7pF	Ceramic	750V	10%	5910-99-911-8271	Erie	P100K
C2	33pF	Trimmer			016-0047	Wingrove & Rogers	C31-01/1
C3	220pF	Silver/Mica	350V	5%	911-6954	Lemco	1106S
C4	14.7pF	Ceramic	750V	10%	011-8301	Erie	N750K
C5	14.7pF	Ceramic	750V	10%	011-8301	"	N750K
C6	14.7pF	Ceramic	750V	10%	011-8301	"	N750K
C7*	10pF	Trimmer			911-4011	Wingrove & Rogers	C32-01
C7†		Piece of twisted wire					
C8	10pF	Ceramic	750V	5%	013-2425	Erie	P100K
C9	100pF	Silver/Mica	350V	5%	911-6953	Lemco	1106S
C10	0.01μF	Paper	500V	20%	012-0123	Hunt	W97/BM21KV
C11	0.005μF	Paper	400V	20%	011-5824	"	W97/BM20Z
C12	14.7pF	Ceramic	750V	10%	011-8301	Erie	N750K
C13	14.7pF	Ceramic	750V	20%	011-8301	"	N750K
C14	0.01μF	Paper	500V	20%	012-0123	Hunt	W97/BM21KV
C15	10pF	Ceramic	750V	5%	013-2425	Erie	P100K
C16	0.01μF	Paper	500V	20%	012-0123	Hunt	W97/BM21KV
C17	0.001μF	Ceramic	350V	+80%—20%		Erie	K350081/AD
C18A	212pF	Variable (2 gang)				Racal	AD15451
C18B		See C18A					
C18C	6.8pF	Ceramic	750V	5%		Erie	P100K
C19	10pF	Ceramic	750V	5%	011-2425	"	P100K
C20	10pF	Ceramic	750V	5%	011-2425	"	P100K
C21	18pF	Trimmer, with acetate case	1000V		972-8322	Oxley	A15/13.2
C22	33pF	Silver/Mica	350V	5%	911-4291	Lemco	1106S
C23	0.001μF	Ceramic	350V	+80%—20%		Erie	K350081/AD

8.3 CAPACITORS (continued)

<i>Cct. Ref.</i>	<i>Value</i>	<i>Description</i>	<i>Rating</i>	<i>Tol.</i>	<i>Joint Service No.</i>	<i>Manufacturer and Type or Drawing No.</i>	
C24	18pF	Trimmer, with acetate case	1000V		5910-99-972-8322	Oxley	A15/13.2
C25	22pF	Silver/Mica	350V	5%	911-4294	Lemco	1106S
C26	0.05 μ F	Paper	350V	25%	011-5559	Hunt	W49/B511K
C27	0.001 μ F	Ceramic	350V	+80%--20%		Erie	K350081/AD
C28	220pF	Silver/Mica	350V	10%	940-9085	Lemco	1106S
C29	0.001 μ F	Ceramic	350V	+80%--20%		Erie	K350081/AD
C30	0.001 μ F	Ceramic	350V	+80%--20%		"	K350081/AD
C31	10pF	Ceramic	750V	5%	013-2425	"	P100K
C32	10pF	Ceramic	750V	5%	013-2425	"	P100K
C33	18pF	Trimmer, with acetate case	1000V		972-8322	Oxley	A15/13.2
C34	39pF	Silver/Mica	350V	5%	911-6837	Lemco	1106S
C35	18pF	Trimmer, with acetate case	1000V		972-8322	Oxley	A15/13.2
C36	33pF	Silver/Mica	350V	5%	911-4291	Lemco	1106S
C37	0.001 μ F	Ceramic	350V	+80%--20%		Erie	K350081/AD
C38	0.001 μ F	Ceramic	350V	+80%--20%		"	K350081/AD
C39	0.1 μ F	Paper	150V	25%	011-5560	Hunt	W49/B500KY
C40	0.001 μ F	Ceramic	350V	+80%--20%		Erie	K350081/AD
C41	0.1 μ F	Paper	150V	25%	011-5560	Hunt	W49/B500KY
C42	220pF	Silver/Mica	350V	5%	911-6954	Lemco	1106S
C42A	0.001 μ F	Ceramic	350V	+80%--20%		Erie	K350081/AD
C43	18pF	Trimmer, with acetate case	1000V		972-8322	Oxley	A15/13.2
C44	39pF	Silver/Mica	350V	5%	911-6837	Lemco	1106S
C45	18pF	Trimmer, with acetate case	1000V		972-8322	Oxley	A15/13.2
C46	33pF	Silver/Mica	350V	5%	911-4291	Lemco	1106S
C47	8.2pF	Ceramic	750V	10%	013-2424	Erie	P100K
C48	0.001 μ F	Ceramic	350V	+80%--20%		"	K350081/AD
C49	0.01 μ F	Paper	500V	20%	012-0123	Hunt	W97/BM21KV
C49A	0.05 μ F	Paper	350V	25%	011-5559	"	W49/B511K
C50	82pF	Silver/Mica	350V	5%	911-6952	Lemco	1106S
C51	220pF	Silver/Mica	350V	5%	911-6954	"	1106S
C52	0.001 μ F	Ceramic	350V	+80%--20%		Erie	K350081/AD
C53	18pF	Trimmer, with acetate case	1000V		972-8322	Oxley	A15/13.2
C54	39pF	Silver/Mica	350V	5%	911-6837	Lemco	1106S
C55	18pF	Trimmer, with acetate case	1000V		972-8322	Oxley	A15/13.2
C56	33pF	Silver/Mica	350V	5%	911-4291	Lemco	1106S
C57	0.001 μ F	Ceramic	350V	+80%--20%		Erie	K350081/AD
C58	0.001 μ F	Ceramic	350V	+80%--20%		"	K350081/AD
C59	0.001 μ F	Ceramic	350V	+80%--20%		"	K350081/AD
C60	0.001 μ F	Ceramic	350V	+80%--20%		"	K350081/AD
C61	18pF	Trimmer, with acetate case	1000V		972-8322	Oxley	A15/13.2
C62	39pF	Silver/Mica	350V	5%	911-6837	Lemco	1106S
C63	18pF	Trimmer, with acetate case	1000V		972-8322	Oxley	A15/13.2
C64	33pF	Silver/Mica	350V	5%	911-4291	Lemco	1106S
C65	0.001 μ F	Ceramic	350V	+80%--20%		Erie	K350081/AD
C66	0.001 μ F	Ceramic	350V	+80%--20%		"	K350081/AD
C67	82pF	Silver/Mica	350V	5%	911-6952	Lemco	1106S
C68	220pF	Silver/Mica	350V	5%	911-6954	"	1106S
C69	0.001 μ F	Ceramic	350V	+80%--20%		Erie	K350081/AD
C70	18pF	Trimmer, with acetate case	1000V		972-8322	Oxley	A15/13.2

8.3 CAPACITORS (continued)

Cct. Ref.	Value	Description	Rating	Tol.	Joint Service No.	Manufacturer and Type or Drawing No.
C71	39pF	Silver/Mica	350V	5%	5910-99-911-6837	Lemco 1106S
C72	18pF	Trimmer, with acetate case	1000V		972-8322	Oxley A15/13.2
C73	33pF	Silver/Mica	350V	5%	911-4291	Lemco 1106S
C74	220pF	Silver/Mica	350V	10%	940-9085	" 1106S
C75*	47pF	Ceramic	750V	5%	013-2288	Erie N750K
C75†	220pF	Silver/Mica	350V	10%	940-9085	Lemco 1106S
C76	100pF	Variable				Wingrove & Rogers C1601 10/012SLF
C77	33pF	Trimmer			016-0047	Wingrove & Rogers C31-01/1 Erie K350081/AD
C78	0.001μF	Ceramic	350V	+80% -20%		Oxley A15/13.2
C79	18pF	Trimmer, with acetate case	1000V		972-8322	
C80	39pF	Silver/Mica	350V	5%	911-6837	Lemco 1106S
C81	18pF	Trimmer, with acetate case	1000V		972-8322	Oxley A15/13.2
C82	33pF	Silver/Mica	350V	5%	911-4291	Lemco 1106S
C83	0.001μF	Ceramic	350V	+80% -20%		Erie K350081/AD
C84	0.001μF	Ceramic	350V	+80% -20%		" K350081/AD
C85	3.3pF	Ceramic	750V	10%	013-2419	" P100K
C86	0.001μF	Ceramic	350V	+80% -20%		" K350081/AD
C87	0.001μF	Ceramic	350V	+80% -20%		" K350081/AD
C88	18pF	Trimmer, with acetate case	1000V		972-8322	Oxley A15/13.2
C89	33pF	Silver/Mica	350V	5%	911-4291	Lemco 1106S
C90	18pF	Trimmer, with acetate case	1000V		972-8322	Oxley A15/13.2
C91	15pF	Silver/Mica	350V	±1pF	911-6850	Lemco 1106S
C92	0.001μF	Ceramic	350V	+80% -20%		Erie K350081/AD
C93	0.001μF	Ceramic	350V	+80% -20%		" K350081/AD
C94	0.001μF	Ceramic	350V	+80% -20%		" K350081/AD
C95	0.01μF	Paper	500V	20%	012-0123	Hunt W97/BM21KV
C95A	0.001μF	Ceramic	350V	+80% -20%		Erie K350081/AD
C96	0.001μF	Ceramic	350V	+80% -20%		" K350081/AD
C97	0.25μF	Paper	150V	25%	011-5563	Hunt W49/B501
C98	0.01μF	Paper	500V	20%	012-0123	" W97/BM21KV
C98A	0.001μF	Ceramic	350V	+80% -20%		Erie K350081/AD
C99	0.001μF	Ceramic	350V	+80% -20%		" K350081/AD
C100	0.001μF	Ceramic	350V	+80% -20%	914-9000	" K3500/AD
C101	0.05μF	Paper	350V	25%	011-5559	Hunt W49/B511KZ
C102	0.001μF	Ceramic	350V	+80% -20%		Erie K350081/AD
C103	0.1μF	Paper	150V	25%	011-5560	Hunt W49/B500KY
C104	0.001μF	Ceramic	350V	+80% -20%		Erie K350081/AD
C105	0.01μF	Paper	500V	20%	012-0123	Hunt W97/BM21KV
C106	0.001μF	Ceramic	350V	+80% -20%		Erie K350081/AD
C107	220pF	Silver/Mica	350V	10%	940-9085	Lemco 1106S
C108	33pF	Trimmer			016-0047	Wingrove & Rogers C31-01/1
C109	220pF	Silver/Mica	350V	2%	911-6839	Lemco 1106S
C110	33pF	Trimmer			016-0047	Wingrove & Rogers C31-01/1
C111	0.001μF	Ceramic	350V	+80% -20%		Erie K350081/AD
C112	0.01μF	Paper	500V	20%	012-0123	Hunt W97/BM21KV
C113	27pF	Ceramic	350V	5%	013-2279	Lemco 1106S
C114	0.001μF	Ceramic	350V	+80% -20%		Erie K350081/AD
C115	0.001μF	Ceramic	350V	+80% -20%	914-9000	" K3500/AD
C116	33pF	Silver/Mica (Assy. with L52)	350V	5%	911-4291	Lemco 1106S

8.3 CAPACITORS (continued)

<i>Cct. Ref.</i>	<i>Value</i>	<i>Description</i>	<i>Rating</i>	<i>Tol.</i>	<i>Joint Service No.</i>	<i>Manufacturer and Type or Drawing No.</i>	
C117	0.01 μ F	Paper	500V	20%	5910-99-012-0123	Hunt	W97/BM21KV
C118	9.3pF	Diff. trimmer			972-8321	Oxley	Mini trimmer
C119	9.3pF	Diff. trimmer			972-8321	"	Mini trimmer
C120	DELETED						
C121	220pF	Silver/Mica	350V	5%	911-6954	Lemco	1106S
C122	70pF	Trimmer, 12 vane with acetate case			972-8320	Oxley	A7/65
C123	SEE C139						
C124	220pF	Silver/Mica	350V	5%	911-6954	Lemco	1106S
C125	70pF	Trimmer, 12 vane with acetate case			972-8320	Oxley	A7/65
C126	SEE C139						
C127	150pF	Silver/Mica	350V	2%	972-9056	Lemco	1006S
C127A	0.01 μ F	Paper	500V	20%	012-0123	Hunt	W97/BM21KV
C128	70pF	Trimmer, 12 vane with acetate case			972-8320	Oxley	A7/65
C129	SEE C139						
C129A	0.1 μ F	Paper	350V	25%	011-5562	Hunt	W49/B512KZ
C130	0.001 μ F	Ceramic	350V	+80% -20%	914-9000	Eric	K3500/AD
C130A	0.01 μ F	Paper	500V	20%	012-0123	Hunt	W97/BM21KV
C131	0.001 μ F	Ceramic	350V	+80% -20%		Erie	K350081/AD
C132	0.001 μ F	Ceramic	350V	+80% -20%		"	K350081/AD
C133	0.001 μ F	Ceramic	350V	+80% -20%		"	K350081/AD
C134	2.2pF	Ceramic	750V	± 25 pF	972-8959	"	N750K
C135	0.1 μ F	Paper	350V	25%	011-5562	Hunt	W49/B512KZ
C136	50pF	Trimmer			016-0004	Wingrove & Rogers	C8-03
C137	270pF	Silver/Mica	350V	5%		Johnson Matthey	C22R
C138	DELETED						
C139	443pF	Variable air (4 Gang)			972-8958	Wingrove & Rogers	C60-04/1
C140	0.05 μ F	Paper	350V	25%	011-5559	Hunt	W49/B511KZ
C141	0.05 μ F	Paper	350V	25%	011-5559	"	W49/B511KZ
C142	0.01 μ F	Paper	500V	20%	012-0123	"	W97/BM21KV
C143	220pF	Silver/Mica	350V	5%	911-6954	Lemco	1106S
C144*	10pF	Silver/Mica	350V	± 1 pF		"	1106S
C144†	22pF	Silver/Mica	350V	± 1 pF		"	1106S
C145	6800pF	Silver/Mica	350V	5%	972-8310	Hunt	L4/37S
C146	270pF	Silver/Mica	350V	2%		Lemco	1106S
C146A	100pF	Ceramic	350V	2%	911-6846	"	316N750
C147	70pF	Trimmer, 12 vane with acetate case			972-8320	Oxley	A7/65
C148	70pF	Trimmer, 12 vane with acetate case			972-8320	"	A7/65
C149	0.001 μ F	Ceramic	350V	+80% -20%	914-9000	Erie	K350081/AD
C150	0.1 μ F	Paper	150V	25%	011-5560	Hunt	W49/B500KY
C151	0.001 μ F	Ceramic	350V	+80% -20%	914-9000	Erie	K350081/AD
C152	290pF	Silver/Mica	350V	2%		Lemco	1106S
C152A	100pF	Ceramic	750V	2%		"	316N750
C153	70pF	Trimmer, 12 vane with acetate case			972-8320	Oxley	A7/65
C154	0.25 μ F	Paper	150V	25%	011-5563	Hunt	W49/B501KZ
C155	0.05 μ F	Paper	350V	25%	011-5559	"	W49/B511KZ
C156	0.01 μ F	Paper	500V	20%	012-0123	"	W97/BM21KV
C157	290pF	Silver/Mica	350V	2%		Lemco	1106S
C157A	100pF	Ceramic	750V	2%		"	316N750
C158	70pF	Trimmer, 12 vane with acetate case			972-8320	Oxley	A7/65

8.3 CAPACITORS (continued)

<i>Cct. Ref.</i>	<i>Value</i>	<i>Description</i>	<i>Rating</i>	<i>Tol.</i>	<i>Joint Service No.</i>	<i>Manufacturer and Type or Drawing No.</i>	
C159	0.05 μ F	Paper	350V	25%	5910-99-011-5559	Hunt	W49/B511KZ
C159A	0.1 μ F	Paper	150V	25%	011-5560	"	W49/B500KY
C159B	0.001 μ F	Ceramic	350V	+80% -20%		Erie	K350081/AD
C160	0.05 μ F	Paper	350V	25%	011-5559	Hunt	W49/B511KZ
C161	290pF	Silver/Mica	350V	2%		Lemco	1106S
C161A	100pF	Ceramic	750V	2%		"	416N750
C162	70pF	Trimmer, 12 vane with acetate case			972-8320	Oxley	GA7/65
C163	0.05 μ F	Paper	350V	25%	011-5559	Hunt	W49/B511KZ
C164	330pF	Silver/Mica	350V	5%	580-2350	Lemco	1106S
C165	0.05 μ F	Paper	350V	25%	011-5559	Hunt	W49/B511KZ
C166	0.05 μ F	Paper	350V	25%	011-5559	"	W49/B511KZ
C167	470pF	Silver/Mica	350V	5%	972-8962	Lemco	1106S
C168	10pF	Ceramic	750V	5%	013-2425	Erie	P100K
C169	0.1 μ F	Paper	150V	25%	011-5560	Hunt	W49/B500KY
C170	2700pF	Silver/Mica	350V	5%	972-8309	"	L4/37S
C170A	33pF	Silver/Mica	350V	5%	911-4291	Lemco	1106S
C171	70pF	Trimmer, 12 vane with acetate case			972-8320	Oxley	A7/65
C172	120pF	Silver/Mica	350V	2%		Lemco	1106S
C173	0.1 μ F	Paper	150V	25%	011-5560	Hunt	W49/B500KY
C174	0.05 μ F	Paper	350V	25%	011-5559	"	W49/B511KZ
C175	33pF	Ceramic	750V	5%	013-2282	Erie	N750K
C176	0.1 μ F	Paper	150V	25%	011-5560	Hunt	W49/B500KY
C177	100pF	Silver/Mica	350V	5%	911-6953	Lemco	1106S
C178	10pF	Ceramic	750V	5%	013-2425	Erie	P100K
C179	70pF	Trimmer, 12 vane with acetate case			972-8320	Oxley	A7/65
C180	100pF	Silver/Mica	350V	2%		Lemco	1106S
C181	0.05 μ F	Paper	350V	25%	011-5559	Hunt	W49/B511KZ
C182	0.1 μ F	Paper	150V	25%	011-5560	"	W49/B500KY
C183	0.05 μ F	Paper	350V	25%	011-5559	"	W49/B511KZ
V184	0.05 μ F	Paper	350V	25%	011-5559	"	W49/B511KZ
C185	0.1 μ F	Paper	150V	25%	011-5560	"	W49/B500KY
C186	0.05 μ F	Paper	350V	25%	011-5559	"	W49/B511KZ
C187	0.05 μ F	Paper	350V	25%	011-5559	"	W49/B511KZ
C188	0.05 μ F	Paper	350V	25%	011-5559	"	W49/B511KZ
C188A	1 μ F	Paper	150V	25%	011-5569	"	W49/B503KY
C189	0.01 μ F	Paper	500V	20%	012-0123	"	W97/BM21KV
C190	0.1 μ F	Paper	150V	25%	011-5560	"	W49/B500KY
C191	70pF	Trimmer, 12 vane with acetate case			972-8320	Oxley	A7/65
C192	390pF	Silver/Mica	350V	2%		Lemco	1106S
C193	100pF	Ceramic	750V	10%	011-2300	Erie	N750L
C193A	0.001 μ F	Ceramic	350V	+80% -20%		"	K350081/AD
C194	0.1 μ F	Paper	150V	25%	011-5560	Hunt	W49/B500KY
C194A	0.001 μ F	Ceramic	350V	+80% -20%	914-9000	Erie	K3500/AD
C195	0.1 μ F	Paper	350V	25%	011-5562	Hunt	W49/B512KZ
C195A	390pF	Silver/Mica	350V	2%		Lemco	1106S
C195B	70pF	Trimmer, 12 vane with acetate case			972-8320	Oxley	A7/65
C196	0.5 μ F	Paper	150V	25%	011-5566	Hunt	W49/B502KY
C197	100 μ F	Electrolytic	50V		014-5515	"	L37/1 85° C JF104
C198	32+32 μ F	Electrolytic (see C206)	350V		972-8308	Plessey	CE818 85° C
C199	220pF	Silver/Mica	350V	5%	911-6954	Lemco	1106S
C200	50pF	Variable				Racal	AD.15051
C201	70pF	Trimmer, 12 vane with acetate case			972-8320	Oxley	A7/65

8.3 CAPACITORS (continued)

Cct. Ref.	Value	Description	Rating	Tol.	Joint Service No.	Manufacturer and Type or Drawing No.	
C202	39pF	Silver/Mica	350V	5%		Lemco	1106S
C203	22pF	Ceramic	750V	5%	5910-99-011-2776	Erie	N750K
C204	0.1 μ F	Paper	150V	25%	011-5560	Hunt	W49/B500KY
C204A†	0.001 μ F	Ceramic	350V	+80% -20%	914-9000	Erie	K3500/AD
C205	0.001 μ F	Ceramic	350V	+80% -20%		"	K350081/AD
C206	SEE C198						
C207	0.05 μ F	Paper	350V	25%	011-5559	Hunt	W49/B511KZ
C208	0.05 μ F	Paper	350V	25%	011-5559	"	W49/B511KZ
C208A†	0.01 μ F	Paper	500V	20%	012-0123	"	W97/BM21KV
C209	330pF	Silver/Mica	350V	5%	580-2350	Lemco	1160S
C210	330pF	Silver/Mica	350V	5%	580-2350	"	1106S
C211	330pF	Silver/Mica	350V	5%	580-2350	"	1106S
C212	0.1 μ F	Paper	150V	25%	011-5560	Hunt	W49/B500KY
C213	0.1 μ F	Paper	150V	25%	011-5560	"	W49/B500KY
C214	0.1 μ F	Paper	350V	25%	011-5562	"	W49/B512KZ
C215	47pF	Ceramic	750V	5%	013-2288	Erie	N750K
C216	0.01 μ F	Paper	500V	20%	012-0123	Hunt	W97/BM21KV
C217	0.1 μ F	Paper	150V	25%	011-5560	"	W49/B500KY
C217A†	0.01 μ F	Silver/Ceramic	750V	20%	972-8307	Lemco	420K
C218	0.01 μ F	Paper	500V	20%	012-0123	Hunt	W97/BM21KV
C218A*	56pF	Silver/Mica	350V	10%		Lemco	1106S
C218A†	33pF	Silver/Mica	350V	10%		"	1106S
C218B*	100pF	Silver/Mica	350V	10%	911-6929	"	1106S
C218B†	68pF	Silver/Mica	350V	10%		"	1106S
C219*	560pF	Ceramic	500V	20%		Erie	K120051A
C219†	0.001 μ F	Ceramic	350V	+80% -20%		"	K350081/AD
C220	560pF	Ceramic	500V	20%		"	K120051A
C220A†	0.1 μ F	Paper	150V	25%	011-5560	Hunt	W49/B500K
C221*	0.001 μ F	Ceramic	350V	+80% -20%	914-9000	Erie	K3500/AD
C221†	0.01 μ F	Paper	500V	20%	012-0123	Hunt	W97/BM21KV
C221A†	8 μ F	Electrolytic	350V	85° C		Plessey	CE502/1
C222	50 μ F	Electrolytic	12V		014-5200	"	CE102/2
C222A†	0.001 μ F	Ceramic	350V	+80% -20%	914-9000	Erie	K3500/AD
C222B†	0.05 μ F	Paper	350V	25%	011-5559	Hunt	W49/B511KZ
C223*	0.001 μ F	Ceramic	350V	+80% -20%		Erie	K350081/AD
C223†	DELETED						
C223A*	0.1 μ F	Paper	150V	25%	011-5560	Hunt	W49/B500KY
C223A†	DELETED						
C224	0.01 μ F	Silver/Ceramic	750V	20%	972-8307	Lemco	420K
C225	0.01 μ F	Silver/Ceramic	750V	20%	972-8307	"	420K
C226	82pF	Silver/Ceramic	750V	5%	972-9990	"	316N750
C227	82pF	Silver/Ceramic	750V	5%	972-9990	"	316N750
C228	82pF	Silver/Ceramic	750V	5%	972-9990	"	316N750
C229	82pF	Silver/Ceramic	750V	5%	972-9990	"	316N750
C230	82pF	Silver/Ceramic	750V	5%	972-9990	"	316N750
C231	82pF	Silver/Ceramic	750V	5%	972-9990	"	316N750
C232 to C237	22pF	Trimmer				Mullard	AC2002/22
8.4 SWITCHES							
S1		Aerial Attenuator			5905-99-972-6987	Racal	BSW10833
S2		Frequency Selection				"	BSW13953
S3		Crystal Filter			972-8852	"	BSW18894
S4		100 kc/s Filter				"	BSW18895— BSW18995— BSW15208/1
S5		System Switch			972-8851	"	SW6
S6		A.V.C.			972-8848	"	BSW19879
S7		B.F.O. (DPCO)			051-0554	NSF	—
S8		Noise Limiter (DPCO)			051-0554	"	—

8.6 VALVES (British)

<i>Cct. Ref.</i>	<i>Description</i>	<i>Joint Service No.</i>	<i>Manufacturer and Type or Drawing No.</i>
V1	Pentode	CV138	EF91
V2	Pentode	CV138	EF91
V3	Double-Triode	CV5531	ECC189
V4	Pentode	CV2209	6F33
V5	Pentode	CV138	EF91
V6	Pentode	CV138	EF91
V7	Pentode	CV3998	E180F
V8	Pentode	CV138	EF91
V9	Pentode	CV3998	E180F
V10	Pentode	CV138	EF91
V11	Heptode	CV4012	6BE6W
V12	Pentode	CV138	EF91
V13	Heptode	CV4012	6BE6W
V14	Pentode	CV454	EF93
V15	Pentode	CV454	EF93
V16	Pentode	CV454	EF93
V17	Pentode	CV454	EF93
V18	Double-Diode	CV140	EB91
V19	Pentode	CV138	EF91
V20	F.W. Rectifier	CV1377	GZ34
V21	Double-Diode	CV140	EB91
V22	Pentode	CV138	EF91
V23	Pentode	CV138	EF91
V24	Diode	CV469	EA76

8.7 VALVES (American)

V1	Pentode	CV2524	6AU6
V2	Pentode	CV2524	6AU6
V3	Double-Triode		6ES8/ECC189
V4	Pentode	CV2522	6AS6
V5	Pentode	CV2524	6AU6
V6	Pentode	CV2524	6AU6
V7	Pentode	CV3998	6688/E180F
V8	Pentode	CV2524	6AU6
V9	Pentode	CV3998	6688/E180F
V10	Pentode	CV2524	6AU6
V11	Heptode	CV4012	6BE6W
V12	Pentode	CV2524	6AU6
V13	Heptode	CV4012	6BE6W
V14	Pentode	CV454	6BA6
V15	Pentode	CV454	6BA6
V16	Pentode	CV454	6BA6
V17	Pentode	CV454	6BA6
V18	Double-Diode	CV283	6AL5
V19	Pentode	CV2524	6AU6
V20	DELETED		
V21	Double-Diode	CV283	6AL5
V22	Output-Tetrode	CV1862	6AQ5
V23	Double triode	CV455	12AT7
V24	Diode	CV469	5704/EA76

(fitted from Ser. No. 3737)

8.8 VALVE AND CRYSTAL HOLDERS

XL1*	Crystal Holder	5935-99-911-6489	McMurdo	X2/UG
XL2, XL3	Valve Holder	5935-99-056-0127	"	—
XL5 and XL6	Screening Can	5960-99-056-3005	"	—
XL1 to XL3†	Crystal Holder		"	X2/UG
XL5 and XL6†			"	

8.8 VALVE AND CRYSTAL HOLDERS (continued)

<i>Cct. Ref.</i>	<i>Description</i>	<i>Joint Service No.</i>	<i>Manufacturer Type Type or Drawing No.</i>	
V1 and V2	Valve Holder	5935-99-056-0127	McMurdo	—
V3	Screening Can	5960-99-056-3003	"	—
V4*	Valve Holder	5935-99-056-0131	"	—
V4†	Screening Can	5960-99-056-3007	"	—
V5 and V6	Valve Holder	5935-99-056-0127	"	—
V7	Screening Can	5960-99-056-3003	"	—
V8	Valve Holder	5935-99-056-0127	"	—
V9	Screening Can	5960-99-056-0146	"	—
V10 to V19	Valve Holder	5935-99-056-0127	"	—
V20*	Screening Can	5960-99-056-3003	"	—
V20†	Valve Holder	5935-99-056-0149	"	X8/U
V21	Valve Retainer		Electrothermal	VR Y10
DELETED				
V22*	Valve Holder	5935-99-056-0127	McMurdo	—
V22†	Screening Can	5960-99-056-3003	"	—
V23*	Valve Holder	5935-99-056-0127	"	—
V23†	Screening Can	5960-99-056-3003	"	—
V24	Valve Holder	5935-99-056-0131	"	—
	Screening Can	5960-99-056-3007	"	—
	Diode Retaining Clip		Sealectro	B-B0147

8.9 INDUCTANCES

L1	0-30 Mc/s filter	5950-99-972-9552	Racal	BD4586
L2	Crystal anode coil	5950-99-972-9565	"	AA4768
L3	Common assembly with L1		"	
L4*	Aerial Tuning		"	BA14099
L4†	Coil Assembly 16-30 Mc/s		"	BA14986
L5*	Aerial Tuning		"	BA14098
L5†	Coil Assembly 8-16 Mcs.		"	BA14985
L6*	Aerial Tuning		"	BA14097
L6†	Coil Assembly 4-8 Mc/s		"	BA14984
L7*	Aerial Tuning		"	BA14096
L7†	Coil Assembly 2-4 Mc/s		"	BA14983
L8*	Aerial Tuning		"	BA14095
L8†	Coil Assembly 1-2 Mc/s		"	BA14982
L9*	Aerial Tuning		"	BA14094
L9†	Coil Assembly 0.5-1 Mc/s		"	BA14981
L10	Common assembly with L1			
L11	Common assembly with L1			
L12	Common assembly with L1			
L13*	Harmonic filter	5950-99-972-9553	"	AD4589
L13†	Filter Detail Assembly		"	AD13715
L14	Common assembly with L13			
L15	Common assembly with L1			
L16	Common assembly with L13			
L17	Common assembly with L1			

8.9 INDUCTANCES (continued)

<i>Cct. Ref.</i>	<i>Description</i>	<i>Joint Service No.</i>	<i>Manufacturer and Type or Drawing No.</i>	
L18	Common assembly with L13			
L19	Common assembly with L13			
L20	First V.F.O. anode coil (assy. with R18)	5950-99-972-9577	Racal	AA4780
L21	Common assembly with L13			
L22	Common assembly with L13			
L23	40 Mc/s filter	5950-99-972-9560	"	AA4761
L24	37.5 Mc/s filter	972-9554	"	AA4632
L25	40 Mc/s filter	972-9560	"	AA4761
L26	37.5 Mc/s filter	972-9554	"	AA4632
L27*	R.F. Amplifier anode coil	972-9558	"	AA4759
L27†	Coil assembly R.F. Amp. anode		"	AA13759
L28*	37.5 Mc/s mixer anode	972-9562	"	AA4763
L28†	Coil assembly 37 Mc/s mixer anode		"	AA13762
L29	40 Mc/s filter	972-9560	"	AA4761
L30	37.5 Mc/s filter	972-9554	"	AA4632
L31	40 Mc/s filter	972-9560	"	AA4761
L32	37.5 Mc/s filter	972-9554	"	AA4632
L33*	37.5 Mc/s amplifier anode	972-9562	"	AA4763
L33†	Coil Assy. 37 Mc/s Amp. Anode		"	AA13762
L34	40 Mc/s filter	972-9560	"	AA4761
L35	37.5 Mc/s filter	972-9554	"	AA4632
L36*	First V.F.O.	914-1791	"	AD4667
L36†	Coil Assy. First V.F.O.		"	AA13734
L37	40 Mc/s filter	972-9560	"	AA4761
L38	37.5 Mc/s filter	972-9554	"	AA4632
L39	40 Mc/s filter	972-9560	"	AA4761
L40	37.5 Mc/s filter	972-9554	"	AA4632
L41	40 Mc/s filter	972-9560	"	AA4761
L42	37.5 Mc/s filter	972-9554	"	AA4632
L43	Choke	972-8084	"	AD16987
L44	Filter coil	972-9555	"	AA4655
L45	Choke	972-8084	"	AD16987
L46	Filter coil	972-9555	"	AA4655
L47	Crystal input transformer	972-9568	"	AA4771
L48	Crystal input transformer	972-9568	"	AA4771
L49	Crystal input transformer	972-9568	"	AA4771
L50	37.5 Mc/s tapped anode coil	972-9569	"	AA4772
L51*	Second mixer anode choke 10 Mc/s	972-9550	"	AA4765
L51†	Second mixer anode choke 10 Mc/s		"	AA13764
L52*	Second mixer trap 37.5 Mc/s	972-9549	"	AA4764
L52†	Second mixer trap 37.5 Mc/s (Assy. with C116)		"	AA13763
L53*	Filter	972-9559	"	AA4760
L53†	Filter coil assembly		"	AA13760
L54*	Filter	972-9559	"	AA4760
L54†	Filter coil assembly		"	AA13760
L55*	Coil Assy. with R70 and C144	972-9551	"	BA10906L
L55†	Coil Assy. with R70 and C144		"	BA13850
L56	Choke	972-8084	"	AD16987
L57*	2-3 Mc/s band-pass filter	972-9563	"	AA4766
L57†	Coil Assy. 2-3 Mc/s		"	AA13765
L58*	2-3 Mc/s band-pass filter	972-9563	"	AA4766
L58†	Coil Assy. 2-3 Mc/s		"	AA13765
L59*	2-3 Mc/s B.P. Filter Transformer	972-9564	"	AA4767
L59†	Transformer Assy. 2-3 Mc/s		"	AA13766
L60	Common assembly with L59			
L61*	First L-C filter stage		"	BA14987
L61†	First L-C filter stage		"	BA15576

8.9 INDUCTANCES (continued)

<i>Cct. Ref.</i>	<i>Description</i>	<i>Joint Service No.</i>	<i>Manufacturer and Type or Drawing No.</i>	
L62	Common assembly with L61		Racal	AA14988
L63*	Second L-C filter stage		"	AA15577
L63†	Second L-C filter stage		"	AA15577
L64	Common assembly with L63		"	AD16987
L65	Choke	5950-99-972-8084	"	AD16987
L66	Filter coil	972-9555	"	AA4655
L67*	Third L-C filter stage		"	AA14988
L67†	Third L-C filter stage		"	AA15577
L68	Common assembly with L67		"	AA4777
L69	0.1 Mc/s coupling coil	5950-99-972-9574	"	AA4777
L70	Common assembly with L69	972-9574	"	AA4777
L71*	Final L-C filter stage	972-9578	"	BA4843
L71†	Final L-C filter stage		"	BA13820
L72*	100 kc/s i.f. first stage		"	pt. of BA10892
L73*			"	
L74*			"	
L72†	100 kc/s i.f. first stage		"	pt. of BA15585
L73†			"	
L74†			"	
L75	0.9 Mc/s anode coil	5950-99-972-9576	"	AA4779
L76*	I.F. output		"	pt. of BA4783
L76†	I.F. output Transformer assy.		"	pt. of BA13819
L77*	100 kc/s i.f. final stage		"	pt. of BA4942
L78*			"	
L79*			"	
L77†	100 kc/s i.f. final stage		"	pt. of BA13822
L78†			"	
L79†			"	
L80*	Smoothing choke	5950-99-972-8943	"	T1081
L80†	Smoothing choke		"	BT15422
L81*	150mH choke	972-9561	"	pt. of AA4762
L81†	150mH choke		"	AA13761
L82	B.F.O.		"	AA14150
L83	Filter coil (Aerial)	911-0554	"	AA10420
L84	Filter coil (Aerial)	911-0554	"	AA10420
L85	Filter coil (Aerial)	911-0554	"	AA10420
L86*	R.F. choke	972-8084	"	AD16987
L86†	(fitted from Ser. No. 3737) R.F. choke	972-8084	"	AD16987

8.10 TRANSFORMERS

T1*	Mains	5950-99-911-6456	Racal	T1078
T1†	Mains		"	BT15421
			(Canadian Atlas Trans. Co. Ltd.)	
T2*	Audio Output	911-6455	Racal	T1079
T2†	Audio Output		"	BT15423
			(Canadian Atlas Trans. Co. Ltd.)	
T3*	A.F. Line Output	911-6454	Racal	T1080
T3†	A.F. Line Output		"	BT15424
			(Canadian Atlas Trans. Co. Ltd.)	

8.11 RECTIFIERS

MR1	Meter Rectifier	6130-99-943-6183	S.E.I. Ltd.	1mA.
MR4 to MR7	Metal Rectifier		A.E.I.	SJ401B
MR8*	Germanium Diode (fitted up to Ser. No. 3736)		G.E.C.	GEX54

8.12 LOUDSPEAKERS

<i>Cct. Ref.</i>	<i>Description</i>	<i>Joint Service No.</i>	<i>Manufacturer and Type or Drawing No.</i>	
*	2½" P.M. 3Ω	5965-99-972-9307	Goodmans	T24/201/3
†	2½" sq. 3Ω		Racal	AD15398
			N.A. ref. Marsland	
			Eng. Ltd.	Model LS.201

8.13 METERS

M1*	200 microamp F.S.D.	6625-99-943-6523	Ernest Turner	W909 (with AD4868f Scale)
M1†	200 microamp		Racal	AD15397
			N.A. ref. Stark Electronic Instruments	Type MR26W200

8.14 CRYSTALS

XL1*	1 Mc/s ±0.005%	ZDK 1000 kc/s	Racal	BD 7822
XL1†	1 Mc/s ±0.005%		"	BD15378
XL2*	100,036 c/s ±0.005%	5955-99-972-9799	C. R. Snelgrove Co. Ltd.	
XL2†	100,036 c/s ±0.005%		Racal	BD7929
			"	BD15373
XL3*	100,110 c/s ±0.005%	5955-99-972-9801	C. R. Snelgrove Co. Ltd.	
XL3†	100,110 c/s ±0.005%		Racal	BD7931
			"	BD15372
XL4	DELETED		C. R. Snelgrove Co. Ltd.	
XL5*	99,964 c/s ±0.005%	5955-99-972-9800	Racal	BD7930
XL5†	99,964 c/s ±0.005%		"	BD15371
			C. R. Snelgrove Co. Ltd.	
XL6*	99,890 c/s ±0.005%	5955-99-972-9802	Racal	BD7932
XL6†	99,890 c/s ±0.005%		"	BD15369
			C. R. Snelgrove Co. Ltd.	

8.15 FUSES AND FUSEHOLDERS

F1	Mains Fuse, 2A	5920-99-059-0110	Belling Lee	L/1055
	Mains Fuseholder	5920-99-059-0100	" "	L/1348
F2*	HT Fuse, 350mA, size 00	5920-99-972-7902	" "	L/562
	HT Fuseholder	5950-99-059-0170	" "	L/575
F2†	Fuse slow blow 350mA		K. Beswick	TDA12/19
	Fuseholder	5920-99-059-0100	Belling Lee	L356

8.16 LAMP AND HOLDER

ILP1	Mains indicating 8V 1.6W Lampholder	6240-99-995-1201 6520-99-943-6863		M.E.S.11mm Rd. M.E.S.5S
------	--	--------------------------------------	--	----------------------------

8.17 VOLTAGE SELECTORS

*Voltage selector socket with plug	5935-99-911-0472	Racal	AD11999A&B
*Voltage selector plug	5935-99-911-0472	"	AD11999/A
*Voltage selector socket		"	AD11999/B

8.18 SUPPLEMENTARY COMPONENTS AND SUB-ASSEMBLIES

Audio Output Terminal Block (12-way)	5940-99-943-8586	Carr Fastener	Series 77/903/12
H.T. Adaptor Terminal Block (2-way)	5940-99-943-8587	" "	Series 77/903/2M
Knobs, tuning (Mc/s and kc/s)	5355-99-943-4816	Racal	BD6781

8.18 SUPPLEMENTARY COMPONENTS AND SUB-ASSEMBLIES (continued)

<i>Cct. Ref.</i>	<i>Description</i>	<i>Joint Service No.</i>	<i>Manufacturer and Type or Drawing No.</i>	
	Knobs, control (AE. TUNE and I.F. GAIN)	5355-99-943-4818	Racal	AA6817
	Knobs, control (A.V.C. and A.F. GAIN)	5355-99-943-4819	"	AA6742
	*Knobs, control (AE. ATT., AE. RANGE, BANDWIDTH and System)		"	AA15472
	†Knobs, control (METER, ANT. ATT. and ANT. RANGE, BANDWIDTH and System)		"	BA13828
	Knob, control (B.F.O.)		"	AD13592
	Skirt (B.F.O. knob)		"	AD15049
	*Knob, tuning lock	5355-99-943-4820	"	AD6762
	†Knob, tuning lock		"	AD13784
	Chain (63 links)	4010-99-911-0581	"	AD4641
	Escutcheon, tuning with windows	5820-99-911-0550	"	BA12009
	*Escutcheon, loudspeaker	5965-99-972-9121	"	AD4848
	†Escutcheon, loudspeaker		"	AD13771
	Slider (kc/s tuning)	5355-99-943-5043	"	AD4568
	Clip and pointer assy. (kc/s tuning)	5355-99-943-5020	"	AA4566
	Film scale	5820-99-943-5022	"	BD9562
	*Cable, UR70	5355-99-6145-100298	"	CA10828/46
	†Cable, UR70	5355-99-6145-100298	"	CA13876/46
	*Trimming tool (AD7955)	5120-99-911-0558	"	DA4500/65
	†Trimming tool (AD7955)	5120-99-911-0558	"	DA13971/65
	*Allen Key $\frac{1}{8}$ " A.F.	5120-99-910-6085	"	DA4500/66
	†Allen Key $\frac{1}{8}$ " A.F.	5120-99-910-6058	"	DA13971/66
	*Allen Key $\frac{3}{16}$ " A.F.		"	DA4500/67
	†Allen Key $\frac{3}{16}$ " A.F.		"	DA13971/67
	*Allen Key 0.050" A.F.	5120-99-910-6057	"	DA4500/69
	†Allen Key 0.050" A.F.		"	DA13971/69
	Cabinet	5957-99-972-8566	"	DA15476
	Cover assembly	5820-99-943-5048	"	CA4640
	Baseplate		"	BD4580
	*Gusset Assembly R.H.	5820-99-943-5021	"	BA4509
	†Gusset Assembly R.H.		"	BA13803
	*Gusset Assembly L.H.	5820-99-943-5049	"	BA4508
	†Gusset Assembly L.H.		"	BA13802
	Screen Assembly (37.5 Mc/s Filter—long)	5999-99-972-8946	"	BA4602
	Screen Assembly (37.5 Mc/s Filter—short)	5999-99-972-8947	"	BA4603
	Screen Assembly (2nd mixer)	5999-99-972-8948	"	BA4604
	Screen Assembly (40 Mc/s Filter—long)	5999-99-972-8949	"	BA4605
	Screen Assembly (40 Mc/s Filter—short)	5999-99-972-8950	"	BA4606
	Screen Assembly (Harm. Gen.)	5999-99-972-8951	"	BA4560
	Screen Assembly (Ae. Att. Sw.)	5999-99-972-8952	"	AA4755
	*Screen Assembly (1st v.f.o.)	5999-99-972-8944	"	CA4582L
	†Screen Assembly (1st v.f.o.)		"	CA13832
	*Screen Assembly (2nd v.f.o.)	5999-99-972-8945	"	BA4581L
	†Screen Assembly (2nd v.f.o.)		"	BA13805
	*First I.F.T. assembly		"	BA10892L
	†First I.F.T. assembly		"	BA15585C12
	*Final I.F.T. assembly	5999-99-940-3480	"	BA4942L
	†Final I.F.T. assembly		"	BA13822C12
	*I.F. O/P T. assembly	5999-99-940-3482	"	BA4783L

8.18 SUPPLEMENTARY COMPONENTS AND SUB-ASSEMBLIES (continued)

<i>Cct. Ref.</i>	<i>Description</i>	<i>Joint Service No.</i>	<i>Manufacturer and Type or Drawing No.</i>	
	†I.F. O/P T. assembly		Racal	BA13819C12
	*B.F.O. assembly	5905-99-913-1761	"	CA4802L
	†B.F.O. assembly		"	CA13855C12
	*Crystal Filter assembly	5999-99-914-1805	"	CA4800L
	†Crystal Filter assembly		"	CA13853C12
	*L-C Filter assembly	5999-99-914-1804	"	CA4801L
	†L-C Filter assembly		"	CA13854C12
	*Ae. Att. switch	5805-99-972-6897	"	BA10833L
	†ANT. Att. switch		"	BA13826C12
	Ferroxcube Bead	5999-99-100-2634	"	FX1115
	Label-self adhesive (Warning) one section	9905-99-972-7468	"	BD4940B
	Label-self adhesive (Warning) Two sections	9905-99-972-7467	"	BD4940A
	*Film Spool (grey plastic)	6760-99-949-0634	"	BD12437
	†Film Spool (grey plastic)		"	BD13827

8.19 MAIN SUB-UNITS

	Main chassis assembly (with screening covers)	5820-99-580-1293	"	AA18182
	*First V.F.O. (Mc/s Drive)	5820-99-913-1498	"	CA14182L
	†First V.F.O. (Mc/s Drive)		"	CA14980C12
	*Second V.F.O. (kc/s Drive)	5820-99-943-3459	"	CA10828L
	†Second V.F.O. (kc/s Drive)		"	CA13876C12
	*100 kc/s i.f. strip (inc. B.F.O.)	5820-99-913-1497	"	CA10884L
	†100 kc/s i.f. strip (inc. B.F.O.)		"	CA13879C12
	*Crystal calibrator unit	6625-99-943-3461	"	CA10845L
	†Crystal calibrator unit		"	CA13880C12
	*Front Panel Assembly		"	CA4833L
	†Front Panel Assembly		"	CA13871C12

Note: For the RA.17C-12, U.N.C. threads are used on both of the output terminal blocks.