

The home of the turntable

# THE VINYL **ENGINE**®

For more turntable manuals and setup information  
please visit [www.vinylengine.com](http://www.vinylengine.com)

# **SERVICE MANUAL**

**STEREO TURNTABLE**

# **PL-15D**

**PV. PVT**

 **PIONEER®**

# CONTENTS

1. SPECIFICATIONS .....	2
2. EXPLODED VIEW AND PARTS LIST .....	3
3. ACCESSORIES PARTS LIST .....	8
4. PACKING METHOD .....	10
5. ADJUSTMENT METHOD .....	11
6. PL-15D CIRCUIT DIAGRAM .....	13



# 1. SPECIFICATIONS

## MOTOR AND TURNTABLE

Motor:	4-pole synchronous
Turntable drive:	Belt-driven
Speed:	Two speeds, 33-1/3, 45 rpm
Wow and flutter:	0.1%(WRMS) or less
S/N:	47dB or more
Turntable platter:	30cm (12in.) diameter die-cast aluminum alloy
Tonearm	Static balance type, pipe arm
Effective arm length:	22.1cm
Furnished cartridge:	PIONEER model PC-30 (Induced magnet type)

## SUBFUNCTIONS

Automatic return tonearm system  
Skating force canceler  
Hydraulic cueing device  
Plug-in type light aluminum head shell  
Dust cover with free stop hinges  
Wooden case with anti-acoustic feedback suspension  
Counterweight with tracking force adjustment gauge

## MISCELLANEOUS

Power requirements:	AC 220 ~ 240V, 110 ~ 130V, 60Hz or 50Hz
Power consumption:	10W (max)
Dimensions:	430(W) x 163(H) x 340(D)mm 16-15/16(W) x 6-7/16(H) x 13-3/8(D) in.
Weight:	7.5kg 16lb 8oz

## ACCESSORIES

Lubricator	1	EP record adaptor	1
Screwdrivers	2	Motor pulley	1
Rubber bush	1	Operating instructions	1

## FURNISHED CARTRIDGE

Type:	Induced magnet type (PC-30)
Frequency response:	10Hz to 23,000Hz
Channel separation:	Better than 20dB at 1,000Hz
Output voltage:	4mV at 1,000Hz (5cm/s or 2ips)
Load impedance:	50k $\Omega$
Stylus:	0.5mil diamond (PN-30)
Compliance:	8 x 10 <sup>-6</sup> cm/dyne at 100Hz (dynamic) 18 x 10 <sup>-6</sup> cm/dyne (static)
Tracking force:	2.2 to 2.8g
Weight:	6g
Mounting:	Conforms to EIA standards 12.7mm (1/2 in.)

## NOTES:

1. Specifications and the design subject to possible modification without notice due to improvements.
2. These instructions apply to both models PL-15D with and without a phono cartridge.

2. EXPLODED VIEW AND PARTS LIST

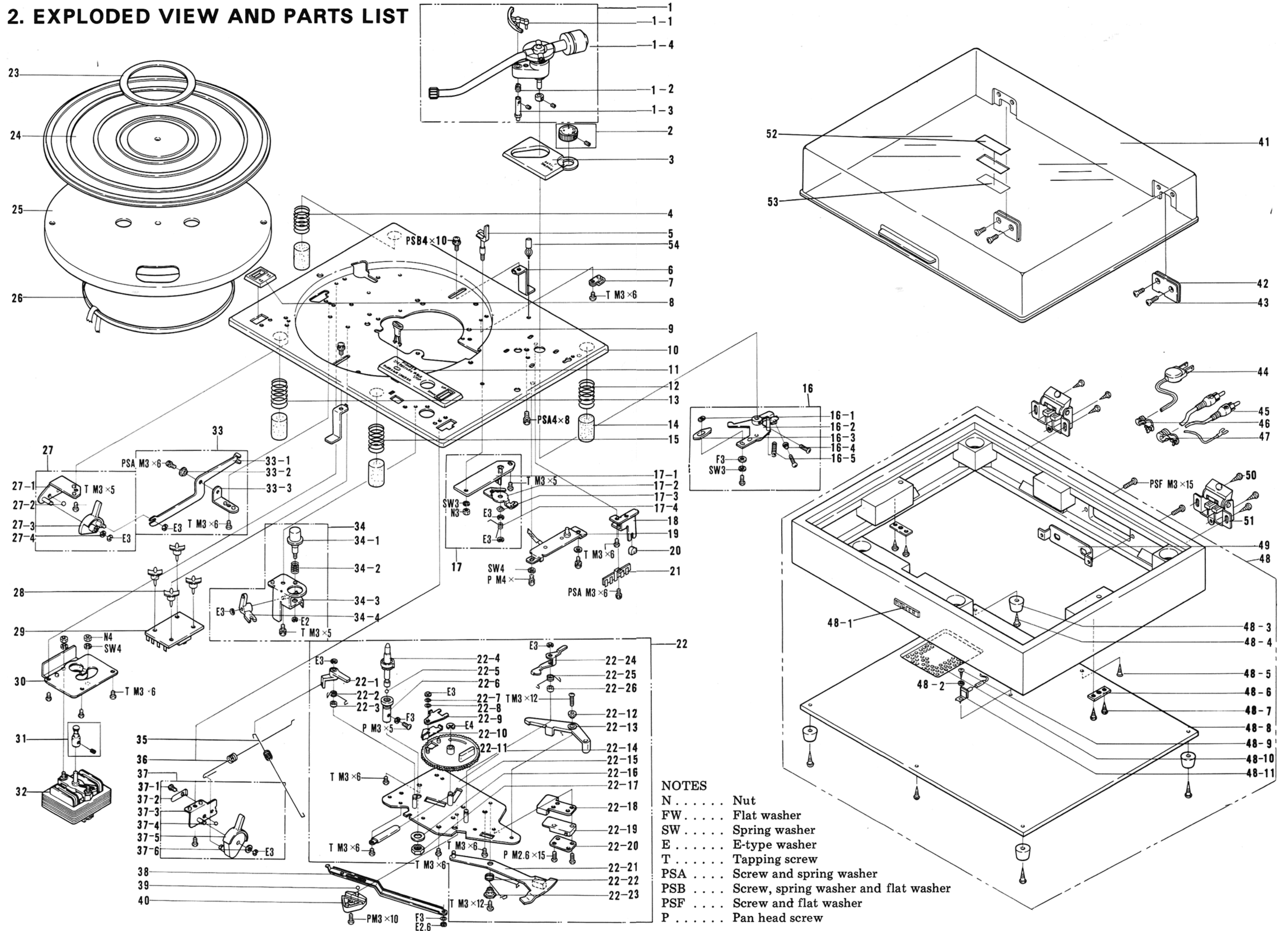

- NOTES  
 N . . . . . Nut  
 FW . . . . . Flat washer  
 SW . . . . . Spring washer  
 E . . . . . E-type washer  
 T . . . . . Tapping screw  
 PSA . . . . . Screw and spring washer  
 PSB . . . . . Screw, spring washer and flat washer  
 PSF . . . . . Screw and flat washer  
 P . . . . . Pan head screw

## PARTS LIST

NOTICE: Any parts asterisked(\*) are subject to being not supplied.

Symbol	Description	Part No.
1	Tonearm assembly	KPD-037-A
1-1*	Elevation	KXB-008-0
1-2	Spring	KBH-135-0
1-3	Elevation unit	KXB-012-0
1-4	Main weight	KXA-566-A
2	Anti-skating knob	KAA-008-B
3	Name plate	KAK-039-A
4	Panel spring(D)	KBH-079-E
5	Arm rest	KXA-391-B
6*	Angle	KNA-680-0
7	Stopper	KHK-113-0
8	Name plate	KAK-023-C
9	Overhang checker	KNK-168-C
10*	Panel	KNA-660-C
11	Name plate	KAK-038-A
12	Panel spring(C)	KBH-078-E
13	Panel spring(C)	KBH-078-E
14	Buffer	E33-001-0
15	Panel spring(D)	KBH-079-E
16	PU plate assembly	KXA-513-0
16-1*	Switch cam nut	KNA-484-0
16-2*	PU plate unit	KXA-514-0
16-3*	Switch cam	KNK-200-B
16-4	Spring	B31-745-B
16-5	Spring	KBH-090-A
17	Elevation assembly	KXA-779-A
17-1*	Elevation base unit	KXA-778-0
17-2*	Elevation base	KNA-682-0
17-3*	Washer	KBE-015-0
17-4	Spring	KBH-130-A
18	Guide angle	KNA-387-A
19	Anti-skating assembly	KXA-502-E
20*	Buffer(A)	KEB-059-0
21	Terminal	K13-026-0
22*	Sub-panel assembly	KXA-771-A
22-1	Cut lever	KNK-201-B
22-2	Cut lever spring	KBH-081-0
22-3*	Collar	KLA-389-0
22-4	Center shaft	KXA-353-B
22-5*	Steel ball	
22-6	Center shaft bearing	KLA-374-A
22-7	Washer 4φ x 0.2t	
22-8	Teflon washer 4φ x 0.2t	
22-9	Plate	KNA-386-C
22-10	Plate	KNA-384-A
22-11	Drive cam unit	KXA-342-C
22-12*	Collar	KLA-390-A
22-13	Lever	KNK-205-B
22-14*	Sub-panel	KXA-352-F
22-15	Cord clamp	KEX-004-0
22-16	Washer	B22-650-0

Symbol	Description	Part No.
22-17	Nut	B71-656-B
22-18*	Microswitch cover	KNK-237-0
22-19	Microswitch	KSF-010-0
22-20*	Spacer	KNK-343-0
22-21	Lever	KXA-354-B
22-22	Lever spring	KBH-082-E
22-23*	Collar	KLA-392-A
22-24	Angle	KNA-391-A
22-25	Spring	KBH-084-A
22-26*	Collar	KLA-389-0
23	Ring	A61-602-A
24	Rubber mat	E31-606-A
25	Turntable platter	KNH-090-0
26	Belt	KEB-004-0
27	Speed selector lever assembly	KXA-344-C
27-1*	Lever angle	KXA-345-B
27-2*	Steel ball 5/32"	
27-3*	Selector lever	KNK-206-A
27-4	Teflon washer 4.2φ x 8φ x 0.3t	
28*	Boss	KNK-186-A
29	Circuit board	KNP-031-A
30*	Motor panel	KXA-471-A
31	Motor pulley	50Hz N24-005-E 60Hz N24-006-E
32	Motor	KXM-026-A
33	Belt guide assembly	KXA-346-B
33-1*	Belt guide	KNA-393-0
33-2*	Belt guide shaft	N51-794-0
33-3*	Angle	KNA-394-B
34	Cut button assembly	KXA-349-D
34-1*	Cut button	KNK-202-B
34-2*	Spring	KBH-080-0
34-3*	Angle	KXA-399-A
34-4	Lever	KNK-203-A
35	Spring rod	KBH-132-0
36	Spring	KBH-131-B
37	Elevation selector assembly	KXA-721-C
37-1	rivet 2.6φ x 4t	
37-2	Spring	KNA-403-B
37-3	Angle	KXA-720-0
37-4*	Steel ball 5/32"	
37-5*	Selector lever	KNK-328-C
37-6	Teflon washer 4.2φ x 8φ x 3t	
38	Lever	KNA-385-B
39*	Steel ball 11/64"	
40	Guide	KNK-204-0
41	Dust cover	KEC-010-0
42	Lock plate	N61-084-0
43	⊕ pan head screw	M4x10
44	Power cord	KDG-007-0

NOTICE: Any parts asterisked(\*) are subject to being not supplied.

Symbol	Description	Part No.	
45	Connection cord	KDE-022-C	
46	Stopper	E32-056-0	
47	Stopper	KNK-244-0	
48	Wooden case assembly	KMM-072-0	
48-1*	Name plate	A61-206-B	
48-2*	Washer M2.6		
48-3	Feet	E31-147-0	
48-4	Wooden screw $\oplus$ 3.1 $\phi$ x20		
48-5	Wooden screw $\oplus$ 3.1 $\phi$ x13		
48-6	Plate	M62-150-0	
48-7	Wooden screw $\oplus$ 3.1 $\phi$ x10		
48-8	Bottom cover	KMS-076-0	
48-9	Wooden screw $\oplus$ 2.4 $\phi$ x6.3		
48-10	Punching	KNA-679-0	
48-11	Terminal	KKC-011-0	
49	Angle	KNA-487-0	
50	Wooden screw $\oplus$ 3.1x10		
51	Hinge	W72-079-B	
52*	Name plate	A55-013-A	
53*	Name plate	A55-014-A	
54	Adaptor holder	N93-007-B	
55			



### 3. ACCESSORIES PARTS LIST

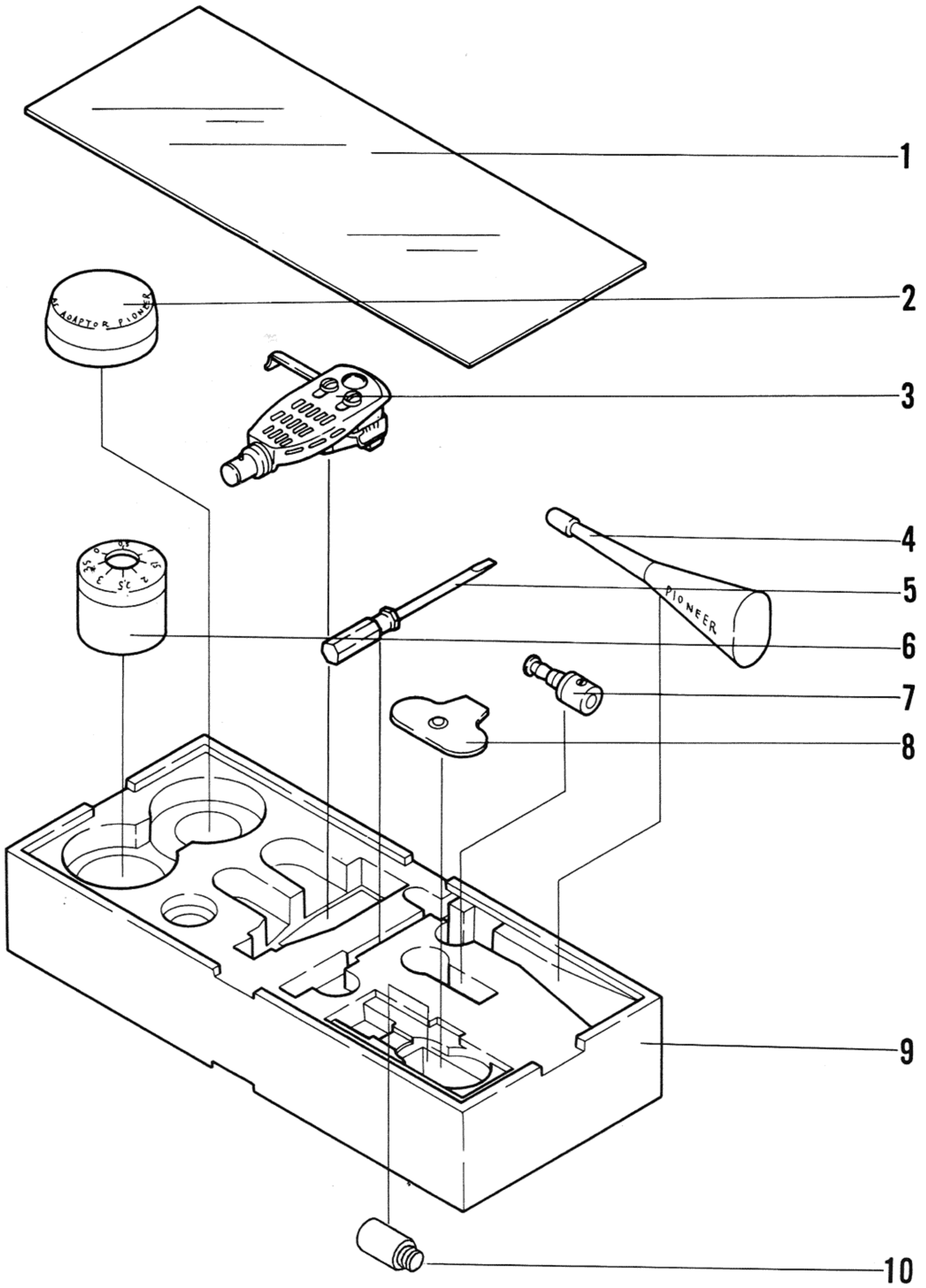

**ACCESSORIES PARTS LIST**

NOTICE: Any parts asterisked(\*) are subject to being not supplied.

Symbol	Description	Part No.
1	Cover	KHX-002-A
2	EP-record adaptor	KNK-055-B
3*	Head shell and cartridge	
4	Lubricator	KEM-001-A
5	Screw driver	KEX-002-A
6	Main weight	KXA-566-A
7	Motor pulley	N24-005-E N24-006-E
		50Hz 60Hz
8	Screw driver	E11-125-A
9	Case	KHX-017-A
10	Sub weight	KLA-494-A

**PACKING PARTS LIST**

NOTICE: Any parts asterisked(\*) are subject to being not supplied.

Symbol	Description	Part No.
1*	Rubber mat assembly	KEA-022-0
1-1	Ring	A61-602-A
1-2	Rubber mat	E31-606-B
1-3	Cardboard	H52-632-0
1-4	Vinyl bag	
2	Packing case	KHK-239-0
3*	Vinyl bag	
4	Dust cover	KEC-010-0
5	Accessories case	KHX-017-A
6	Vinyl cover	H56-603-0
7*	PL-15D	
8	Screw	B11-054-0
9	Washer	B22-026-0
10	Stylotector (R)	KNK-165-E
11	Stylotector (L)	KNK-164-E
12*	Vinyl bag	
13	Turntable platter	KNH-090-0
14	Operating instructions	KRB-041-0
15*	Vinyl bag	

### 4. PACKING METHOD

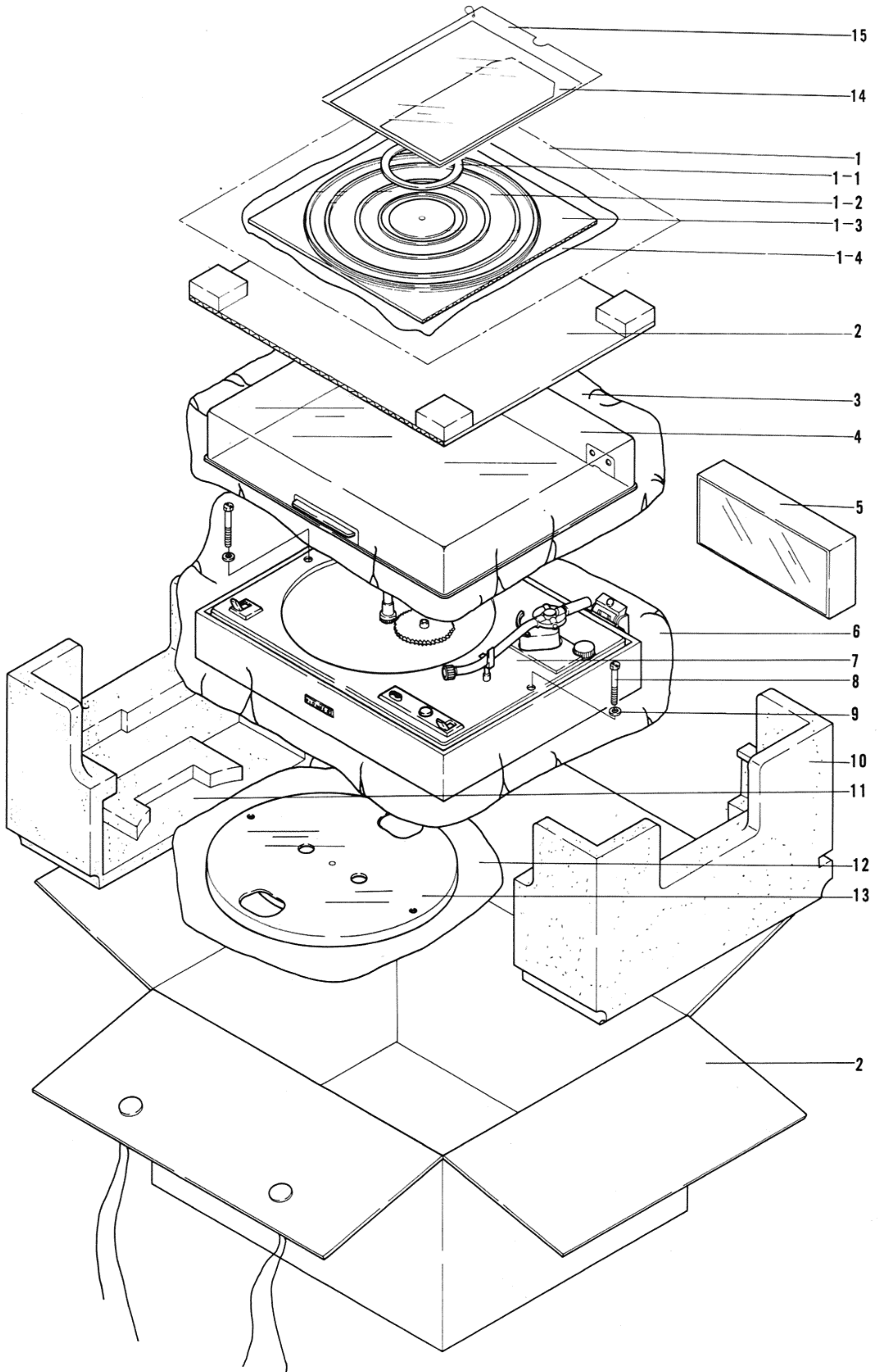

## 5. ADJUSTMENT METHOD

### Drive Cam Unit Adjustment

As shown in Fig. 1, adjust the drive cam unit so the center of its nontoothed part intersects the line from the center shaft to the drive cam shaft. Adjust by turning the hex nut a little at a time.

**NOTE:**

It is not necessary to loosen the screw in the center of the hex nut.

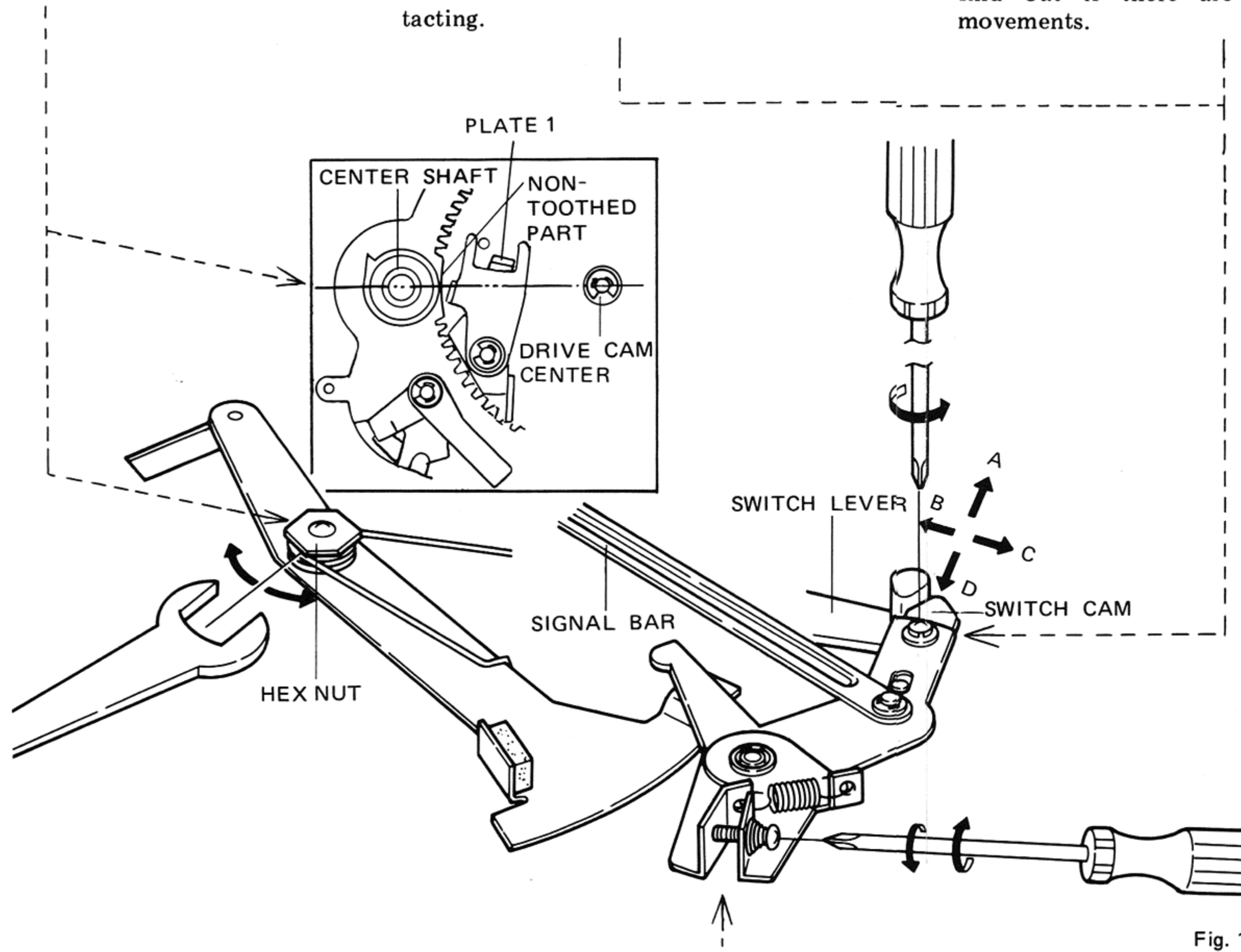

Fig. 1

### Switch Cam Adjustment

Adjust so the turntable starts to rotate when the tonearm is near the outer edge of the turntable.

If the following incorrect movements (items A, B, C, D) are found, move the switch cam in the arrow-indicated direction such as to A ↑, B ←, C →, and D ↓, according to the respective item to be adjusted.

A ↑: When the tonearm is operating and the switch cam and switch lever are not contacting.

B ←: When the tonearm is too far toward the center when the turntable starts rotating.

C →: When the tonearm is too far toward the outside edge when the turntable starts rotating.

D ↓: When the switch cam and switch lever are contacting but the arm movement is not smooth.

Try to move the switch cam in various ways to find out if there are two more incorrect movements.

### Signal Bar Adjustment

Adjust when the tonearm auto-return does not operate or the tonearm return is too rapid. Adjust so the signal bar begins to push Plate 1 when the tonearm is at a point 64 mm from the center shaft.

Turn the screw in the ↻ direction when plate 1 is pushed too soon. Turn the screw in the ↻ direction when plate 1 is pushed too late.

### Tonearm Elevation Adjustment

While the tonearm is being now returned and the clearance between the record surface and the stylus tip is less than 5 mm, adjust the elevation to 5 mm to 8 mm using the screw shown in Fig. 2.

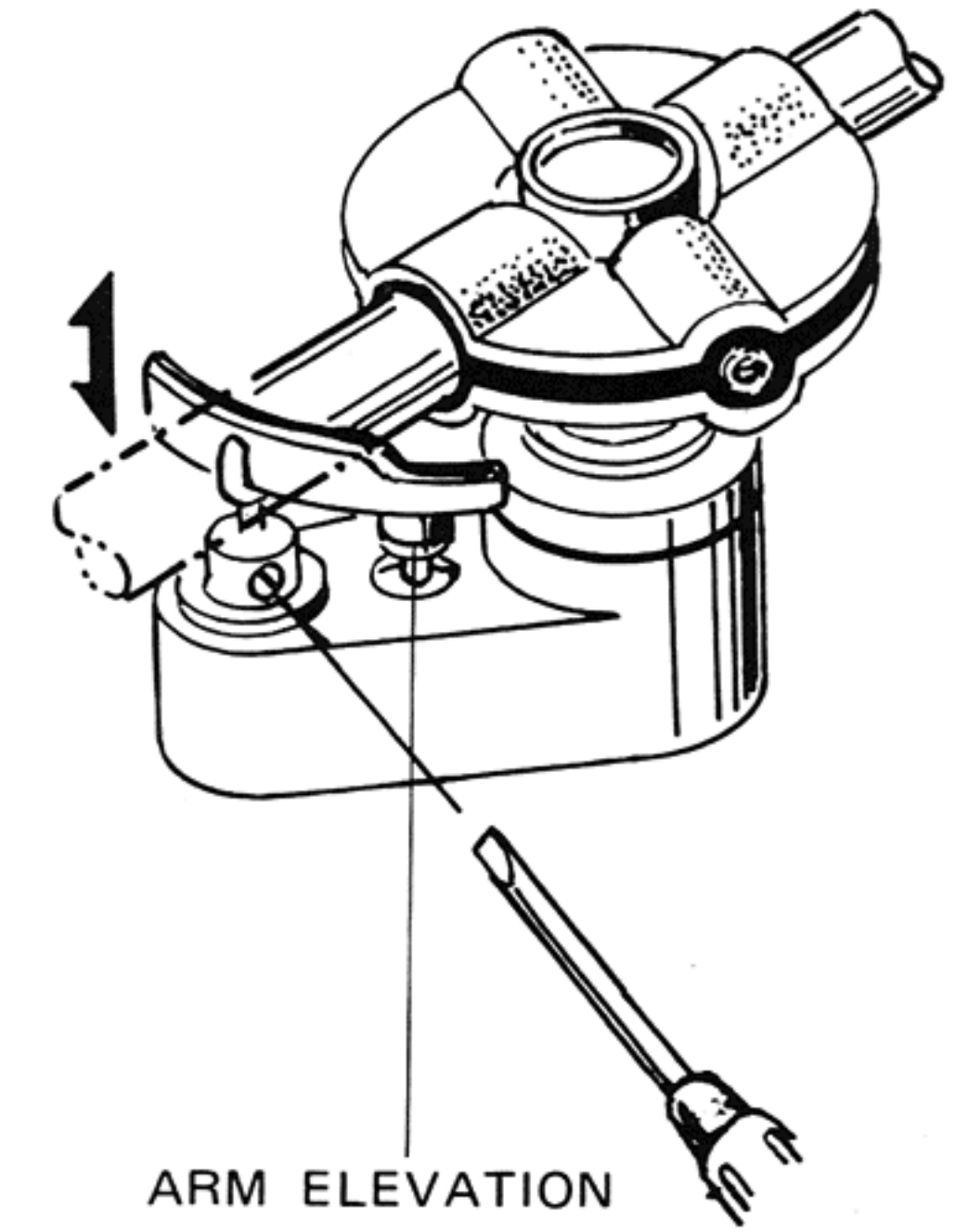

Fig. 2

### Tonearm Elevation Speed Adjustment

Elevation speed of tonearm can be changed by spring to which elevation mechanism is fitted. For making speed faster; Hook spring at split E. For making speed slower; Hook spring at split A.

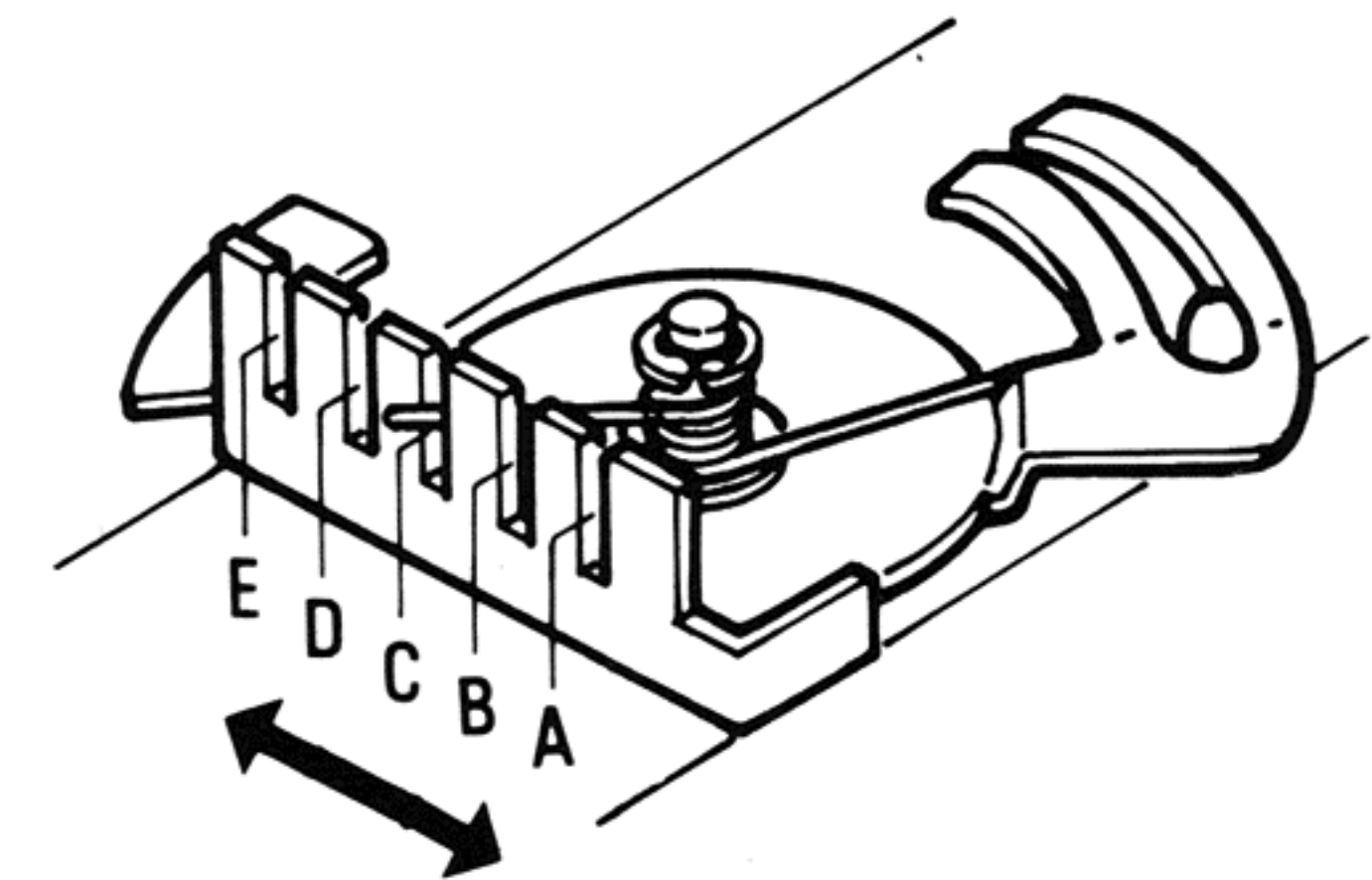
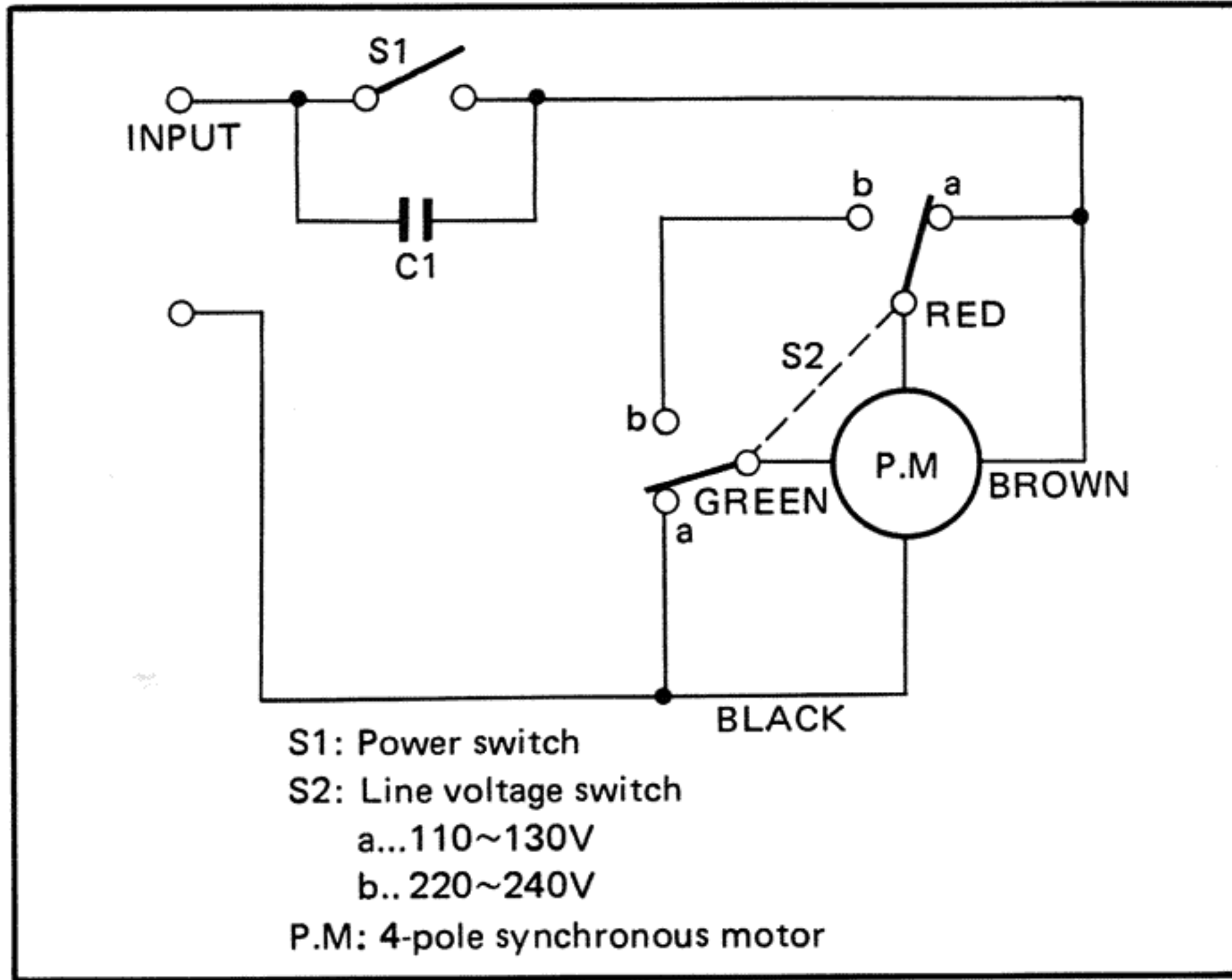

Fig. 3

## 6. PL-15D CIRCUIT DIAGRAM



### Parts List

Symbol	Description	Part No.
S1	Power switch	
S2	Line voltage switch	RSH-003-A
C1	Capacitor 0.047 $\mu$ F 200V AC	KCE-005-0
P.M	Phono motor	KXM-026-A

**PIONEER ELECTRONIC CORPORATION**

15-5, 4-Chome, Ohmori-nishi, Ohta-ku, Tokyo, Japan

**U.S. PIONEER ELECTRONICS CORPORATION**

178 Commerce Road, Carlstadt New Jersey 07072 U.S.A.

**PIONEER ELECTRONIC (EUROPE) N.V.**

Meir-center, Meir 21, 2000 Antwerp, Belgium

JUNE 1973

PRINTED IN JAPAN