

PHILCO RADIO & TELEV. CORP.

MODEL 45
Alignment Data
Voltage, Layouts

Model 45

Philco Model 45 is a six tube receiver operating on alternating current and capable of receiving either standard and police broadcasts between 540 and 1720 kilocycles, or short-wave stations between 4.2 and 13 megacycles. The left hand side of the dial is calibrated in kilocycles for standard reception and the right in megacycles for short-wave stations. A two-position switch changes reception from standard to short-waves.

Model 45 uses a type 6-A-7 detector-oscillator, two type 39-44 I. F. Tubes, type 75 2d detector, type 42 output tube, and type 80 rectifier. The power consumption is 65 watts. The intermediate frequency is 460 K.C.

Power Transformer Voltages

Terminals	Volts	Circuit	Color Leads
1-2	120	Primary	White
3-4	5.0	Fil. of 80	Blue
5-7	680	Plates of 80	Yellow
8-10	6.3	Filaments	Black
6	...	Center of 5-7	Yellow-Green tr.
9	...	Center of 8-10	Black-Yellow tr.

Tube Socket Voltages

CIRCUIT	Det. Osc.	1st IF	2d IF	2d Det.	Out-put	Rect.
Type Tube	6A7	39-44	39-44	75	42	80
Filament (F to F).....	6.3	6.3	6.3	6.3	6.3	6.0
Plate (P to K).....	280	265	265	175	280	335
Screen Grid (SG to K).....	G1-85 G2-135 G3&5-85	75	75	...	280	...
Cathode (K to F).....	4.2	3.8	3.8	0	0	...

The above tests were made with an AC voltmeter for filament voltages and a high resistance DC voltmeter for all others. Dial at 850 KC, volume control at maximum. Test made with test prods applied to socket terminals underneath chassis. Line voltage 115.

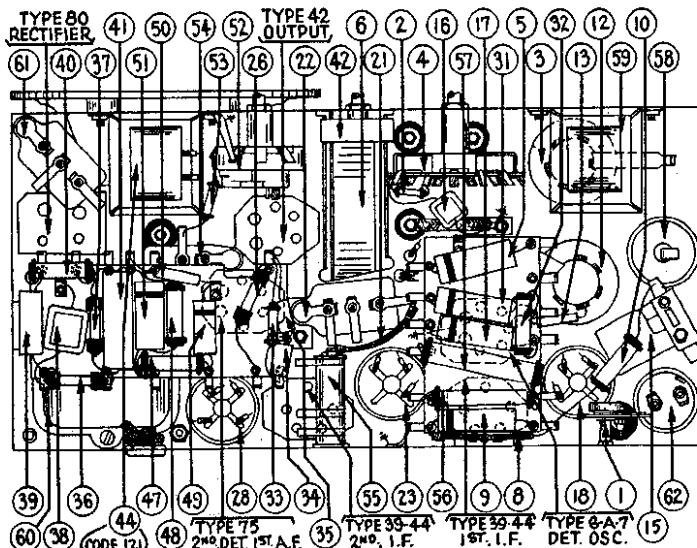

Fig. 4—Bottom View Showing Parts

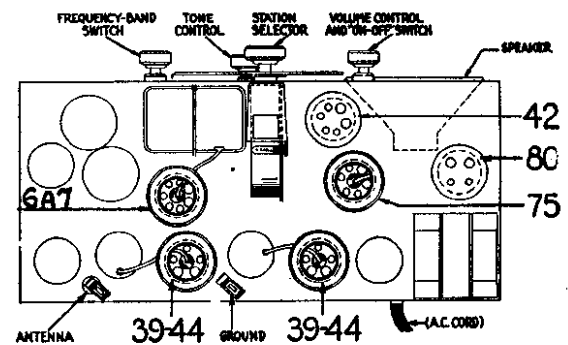

Fig. 2—Chassis Top View

Adjusting Compensating Condensers

For adjustment of compensating (padding) condensers in model 45, an accurately calibrated signal generator and a special insulated padding wrench are needed. We suggest the Philco Model 024 Signal Generator or the 048 Tester which includes a similar instrument.

The chassis must be removed from cabinet in order to make all adjustments.

Adjustments are made in the following order—

ADJUSTMENT OF THE INTERMEDIATE FREQUENCY—Remove the grid clip from the type 6A7 tube and connect the "ANT" output terminal of the signal generator to the grid cap of the tube. Connect the "GND" terminal of the signal generator to the "GND" terminal of the receiver chassis.

Connect the output meter to the primary terminals of the output transformer. Set the signal generator at 460 K.C. (the intermediate frequency of Model 45) and with the receiver and signal generator turned on, the wave band switch at left and dial at 600 K.C., adjust each of the I. F. compensating condensers in turn, to give maximum response in the output of the receiver. The three pairs of I. F. compensating condensers are located one pair at the top of each of the three I. F. transformer shields. These are the three metal "cans" near the rear of the chassis. Each of the transformers has a dual compensating condenser mounted at its top, and accessible thru a hole in the top of the coil shield. In the dual compensators, the Primary circuit is adjusted by turning the screw; the Secondary circuit is adjusted by turning the hex-head nut.

ADJUSTMENT OF THE WAVE TRAP—Replace the grid clip upon the Detector-Oscillator tube (Type 6A7). Connect the output leads from the signal generator directly to the antenna and ground terminals of the receiver. Set the Wave-Band Switch of the receiver to the standard broadcast band (left hand position) and the Station Selector at the low frequency (540 K.C.) end. Adjust the Wave Trap condenser to give MINIMUM response to a 460 K.C. signal from the signal generator. The Wave Trap ① is located at rear and underneath the chassis, and is shown in Figure 4. It is reached from the rear of the chassis, by inserting the fibre wrench thru the hole near right-hand rear corner of chassis.

DETECTOR, AND OSCILLATOR "HIGH" AND "LOW" FREQUENCY ADJUSTMENTS—The "antenna" and "oscillator H. F." compensators are located on top of the tuning condenser assembly, reached from above.

Set the signal generator at 1500 K.C., tune in this signal on the set and adjust the antenna compensator ② (nearest tuning control) to give maximum reading in the output meter.

Next adjust the oscillator H. F. condenser ③ (located on the other section of tuning condenser) to maximum reading.

Finally set the signal generator at 600, tune in this signal and adjust the oscillator "L. F. condenser", located underneath chassis ④ in Fig. 4) to maximum reading. This adjustment is reached thru the hole in top of chassis, between the two electrolytic condensers (left hand end of chassis when facing rear).

MODEL 45
Schematic
Parts List
Socket Layout

PHILCO RADIO & TELEV. CORP.

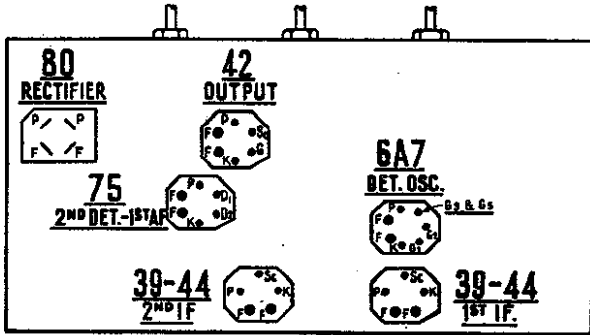
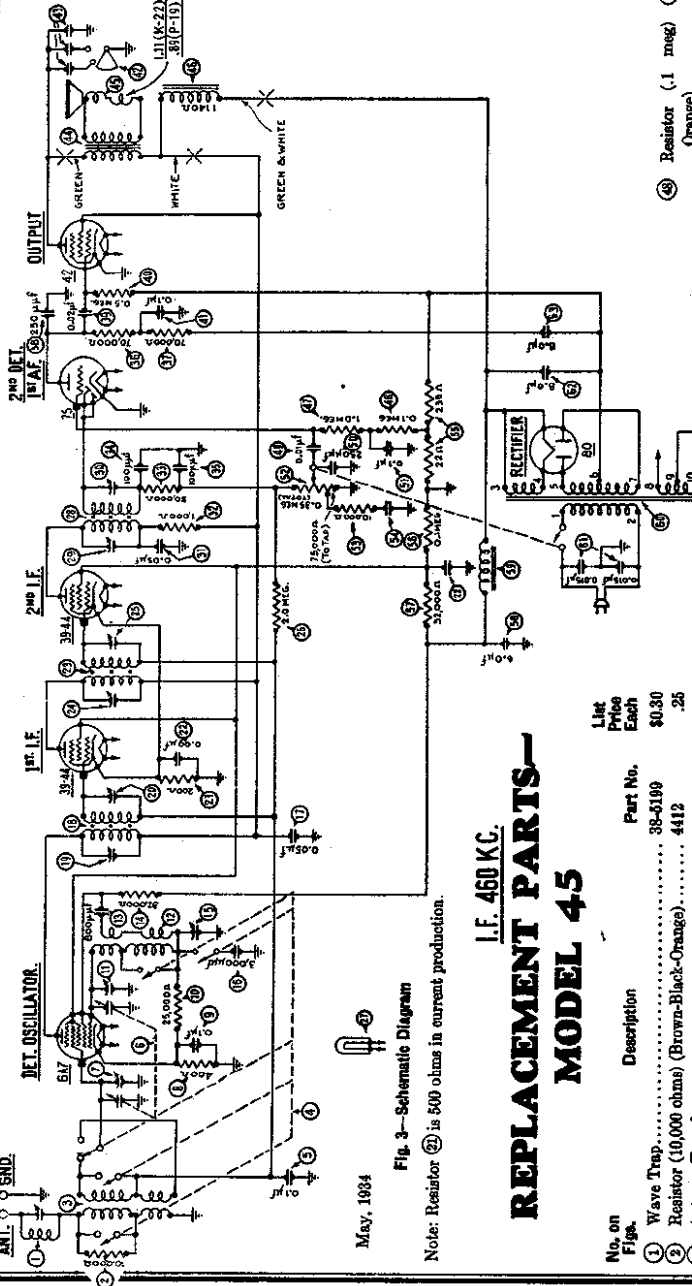

Fig. 1—Tube Socket Layout (underside)



May, 1934

Fig. 3—Schematic Diagram

Note: Resistor (21) is 500 ohms in current production.

**REPLACEMENT PARTS—
MODEL 45**

I.F. 460 KC.

No. on Figs.	Description	Part No.	Qty.	Price Each
1	Wave Trap.....	32-5199	1	\$0.30
2	Resistor (10,000 ohms) (Brown-Black-Orange).....	4412	25	.25
3	Antenna Transformer.....	32-1360	1	.60
4	Wave Band Switch.....	42-1062	1	1.10
5	Condenser (.1 Mfd.) (Tubular).....	30-4122	35	.35
6	Tuning Condenser Assembly.....	31-1169	1	4.40
7	Compensating Condenser (Det.).....	Part of 6		
8	Resistor (400 ohms—flexible wire wound).....	32-3016	20	.20
9	Condenser (.1 Mfd.) (Tubular).....	30-4122	35	.35
10	Resistor (25,000 ohms) (Red-Green-Orange).....	4516	25	.25
11	Compensating Condenser (Sec. H. F.).....	Part of 8		
12	Oscillator Transformer.....	32-1361	1	.45
13	Condenser (.0008 Mfd.—Mica).....	5878	35	.35
14*	Resistor (32,000 ohms) (Orange-Red-Orange).....	3256	25	.25
15	Compensating Condenser (Sec. L. F.).....	04000-S	1	.35
16	Condenser (.008 Mfd.—Mica).....	7801	45	.45
17	Condenser (.05 Mfd.—Tubular).....	30-4123	35	.35
18	1st I. F. Transformer.....	32-1362	1	1.50
19	Compensating Condenser (1st I. F. Primary).....	Part of 18		
20	Compensating Condenser (1st I. F. Secondary).....	Part of 18		
21	Resistor (500 ohms—flexible wire wound).....	6977	20	.20
22	Condenser (.09 Mfd. twin) (Bakelite block).....	4989-2	40	.40
23	2d I. F. Transformer.....	32-1363	1	1.50
24	Compensating Condenser (2d I. F. Primary).....	Part of 23		
25	Compensating Condenser (2d I. F. Secondary).....	Part of 23		
26	Resistor (2 mega) (Red-Black-Green).....	5872	25	.25
27	Pilot Lamp.....	6608	1	.11
28	3d I. F. Transformer.....	32-1364	1	1.55
29	Compensating Condenser—3d I. F. Primary.....	Part of 28		
30	Compensating Condenser—3d I. F. Secondary.....	Part of 28		
31	Wave Trap.....	32-5199	1	.30
32	Resistor (1 meg) (White-White-Orange).....	4411	25	.25
33	Condenser (.01 Mfd. Tubular).....	30-4124	35	.35
34	*Does not appear in Fig. 4.			
35	Condenser (.0025 Mfd. Mica).....	5868	25	.25
36	Condenser (1 Mfd. Tubular).....	30-4122	35	.35
37	Volume Control and On-Off Switch.....	32-4066	1	1.45
38	Resistor 10,000 ohms (Brown-Black-Orange).....	33-1000	25	.25
39	Condenser (Code 121) (.05 Mfd.) (Bakelite Block).....	3315-W	35	.35
40	Condenser (Code 122) (.09 Mfd.) (Bakelite Block).....	4989-AM	35	.35
41	Volume Control and On-Off Switch.....	32-4066	1	1.45
42	Output Transformer.....	32-7041	1	1.50
43	Filter Choke.....	32-7018	1	1.50
44	Power Transformer.....	32-7226	1	4.25
45	Condenser (.015 Mfd. twin—Bakelite block).....	5793-E	40	.40
46	Condenser (Electrolytic 8-8 Mfd. 450 Volts).....	30-3028	1	2.40
47	A. C. Cord and Plug Assembly.....	L-945-A	1	.60
48	Tube Shield.....	25-1107	10	.10
49	Four Prong Socket.....	4955	10	.10
50	Five Prong Socket.....	4955	11	.11
51	Six Prong Socket.....	6417	11	.11
52	Seven Prong Socket.....	4957	11	.11
53	Speaker Socket (Lowboy set—code 122).....	37-4006	10	.10
54	Knob.....	37-4032	10	.10
55	Knob (Large) (Lowboy only).....	37-4031	10	.10
56	Dial Assembly.....	37-4031	1	.45
57	Dial Scale.....	37-4031	1	.45
58	Mounting screws (Compact set).....	37-4042	17	.17
59	Mounting Washers (Compact set).....	W-1345	17	.17
60	Foot (Rubber).....	5049	2	.55
61	Foot (Rubber).....	27-4116	2	.55