

Specifications

Circuit :	9 Transistor Superheterodyne
Frequency Coverage :	FM 86.5~108 Mc (3.53~2.78 m) MW 530~1,605 Kc (566~187 m)
Antenna System :	FM Built-in Telescopic Antenna MW Built-in Ferrite Bar Antenna
Intermediate Frequency :	FM 10.7 Mc MW 455 Kc
Maximum Sensitivity : (at 10 mW Output)	FM 15 dB MW 42 dB
Selectivity :	22 dB at 10 Kc off resonance, at 1,400 Kc
Output Power :	140 mW (undistorted) 260 mW (maximum)
Current Drain :	16 mA (FM), 12 mA (MW) at zero signal, 60 mA at 140 mW output
Speaker :	2-1/2" (6 cm) PM dynamic, 8Ω
Power Source :	Three Size "AA or Z" Penlight Batteries (4.5 Volts in total)
Dimensions :	117.5 (H) × 71 (W) × 33 (D)mm (4-5/8 × 2-13/16 × 1-5/16")
Weight :	0.55 lb. (0.25 Kg.)

Frequency Coverage and Tracking Adjustment

AM Band

Preparation for Adjustments

- ☆ Receiver to be adjusted
 - Power Source Voltage : Keep 4.5 Volts during the adjustments.
 - Volume Control setting : Maximum
 - Band Switch setting : AM
- ☆ Signal Source : Use a SSG (Standard Signal Generator) which can deliver RF signals modulated at 30% with 1,000 c/s.
- ☆ Load for Output : Connect an 8Ω resistor instead of speaker.
- ☆ Output Meter : Connect across the load resistor 8Ω.
(VTVM can be used also.)
- ☆ Radiating Antenna : Use a loop type.

a) Frequency Coverage Adjustment

- (1) Deliver a 520 Kc signal from the SSG.
- (2) Set the Tuning Capacitor at the maximum capacitance position by turning the Tuning Knob of the Receiver counter-clockwise.
- (3) Adjust the core of the MW OSC Coil (L₂₀₂) to tune to the signal.
- (4) Set the Tuning Capacitor at the minimum capacitance position by turning the Tuning Knob of the Receiver clockwise.
- (5) Deliver a 1,680 Kc signal from the SSG.
- (6) Adjust the MW OSC Trimmer Capacitor (C₂₋₄) to tune to the signal.
- (7) Repeat the above procedures (1~6) until the frequency range between 520 Kc and 1,680 Kc is fully covered.

b) Tracking Adjustment

- (1) Deliver a 620 Kc signal from the SSG.
- (2) Tune to the signal by turning the Tuning Knob of the Receiver.
- (3) Adjust the position of the MW ANT Coil (L₂₀₁) along the Ferrite Bar to obtain the maximum output.
- (4) Deliver a 1,400 Kc signal from the SSG.
- (5) Tune to the signal by turning the Tuning Knob of the Receiver.
- (6) Adjust the MW ANT Trimmer Capacitor (C₂₋₃) to obtain the maximum output.
- (7) Repeat the above procedures (1~6) until the maximum output is obtained.

FM Band

Preparation for Adjustments

- ☆ Receiver to be adjusted
 - Power Source Voltage : Keep 4.5 Volts during the adjustments.
 - Volume Control setting : Maximum
 - Band Switch setting : FM
- ☆ Load for Output : Connect an 8Ω resistor instead of Speaker.
- ☆ Output Meter : Connect across the load resistor 8Ω.
(VTVM can be used also.)
- ☆ Signal Source : Use a SSG (Standard Signal Generator) which can deliver RF signals modulated at 30% with 1,000 c/s.
- ☆ Dummy Antenna : Unsolder the lead wire (White) at the Telescopic Antenna terminal.
Connect the SSG to the telescopic antenna lead and ground of the receiver through the Dummy Antenna as shown in Fig. 6.

Tuner Section
—Printed Side—

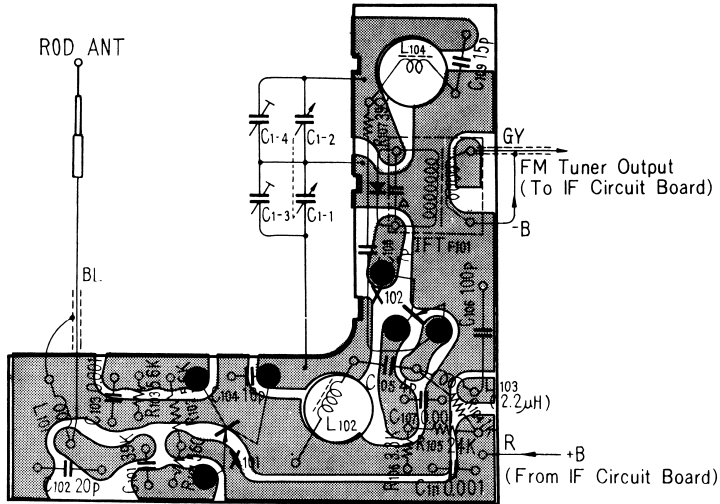

—Parts Side—

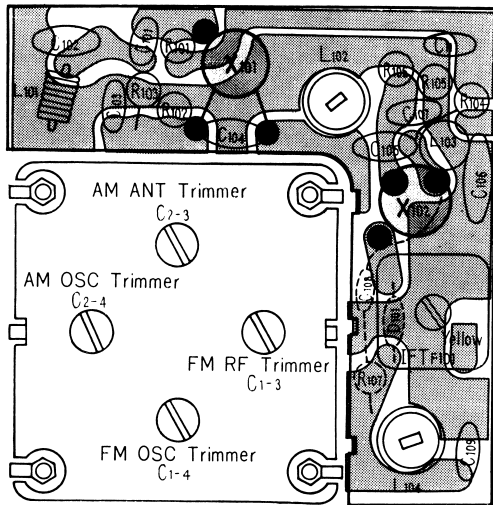

Mounting Diagram

IF Section
—Printed Side—

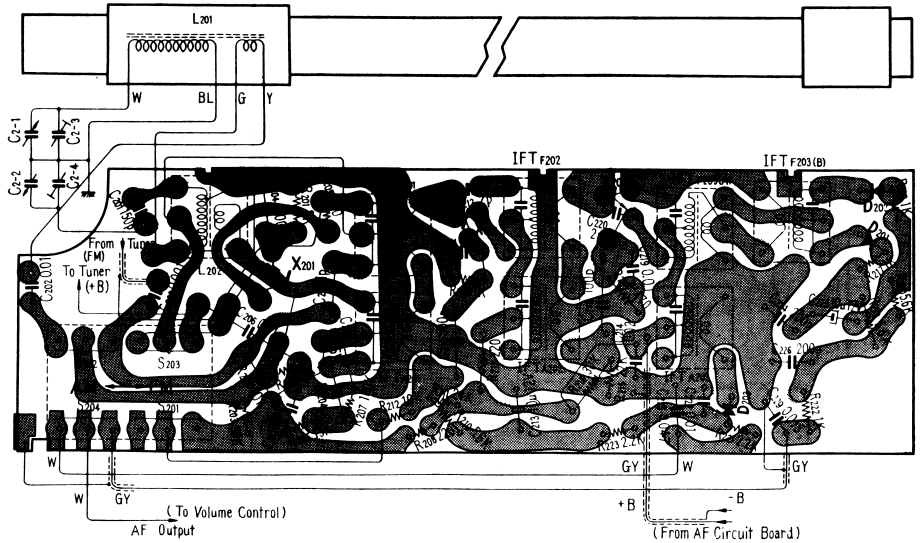

—Parts Side—

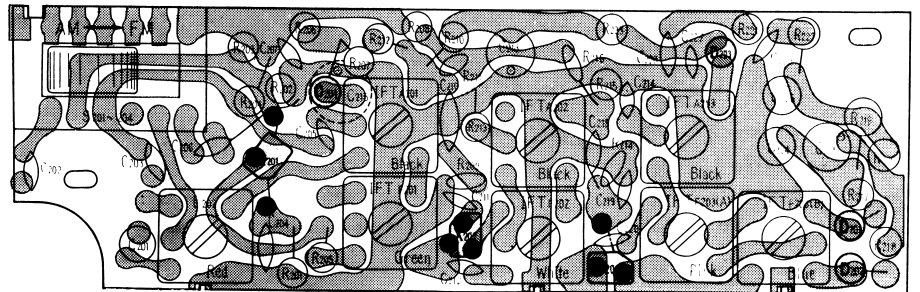

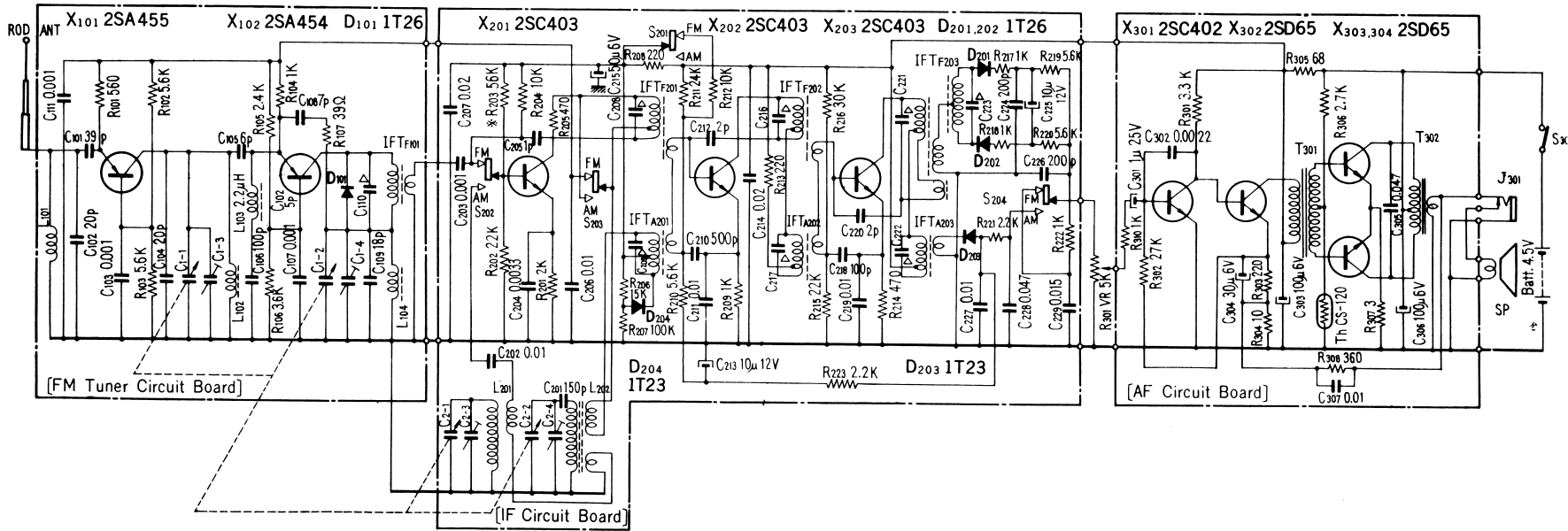

- * : To be adjusted
- Capacitors marked with Δ are built in relative IF Transformers.
- Position of the Band Switch (S₂₀₁-204) in the Diagram shows FM side.

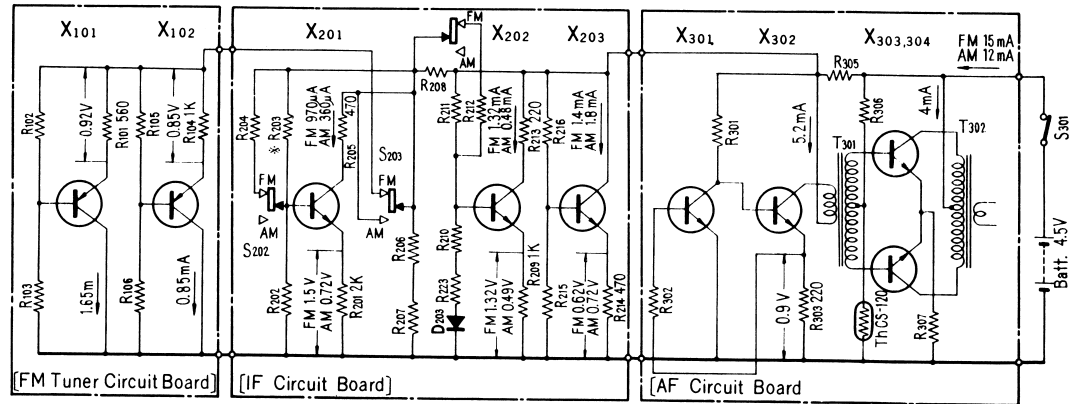

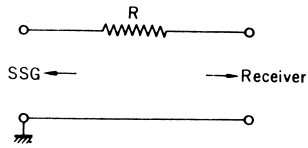

* Nominal input impedance of the receiver is 100Ω.

* R is then calculated as follows :

$$R = 100 - R_s [\Omega]$$

where R_s is output impedance of the SSG which is usually 50Ω or 75Ω.

a) Frequency Coverage Adjustment

- (1) Deliver a 85.5 Mc signal from the SSG.
- (2) Set the Tuning Capacitor at the maximum capacitance position by turning the Tuning Knob of the Receiver counter-clockwise.
- (3) Adjust the core and gap of the FM OSC Coil (L_{104}) to tune to the signal.
- (4) Deliver a 109.5 Mc signal from the SSG.
- (5) Set the Tuning Capacitor at the minimum capacitance position by turning the Tuning Knob of the Receiver clockwise.
- (6) Adjust the FM OSC Trimmer Capacitor (C_{1-4}) to tune to the signal.
- (7) Repeat the above procedures (1~6) until the frequency range between 85.5 Mc and 109.5 Mc is fully covered.

b) Tracking Adjustment

- (1) Deliver a 85.5 Mc signal from the SSG.
- (2) Tune to the signal correctly by turning the Tuning Knob of the Receiver.
- (3) Adjust the FM RF Coil (L_{102}) for the maximum reading on the Output Meter.
- (4) Deliver a 109.5 Mc signal from the SSG.
- (5) Tune to the signal correctly by turning the Tuning Knob of the Receiver.
- (6) Adjust the FM RF Trimmer Capacitor (C_{1-3}) to obtain the maximum output.
- (7) Repeat the above procedures (1~6) until the maximum output is obtained.

To String the Dial Cord

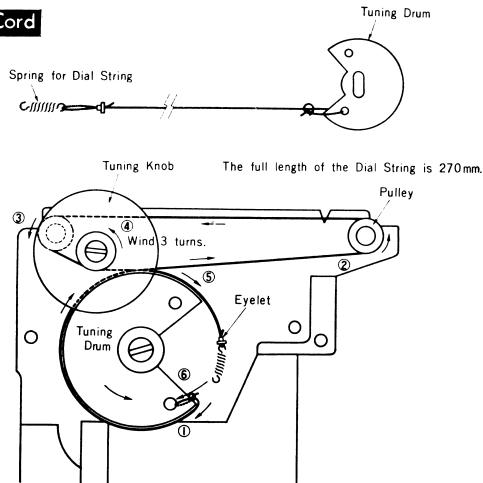

Set the Tuning Capacitor counter-clockwise to the full before the Dial String is routed around the Tuning Drum.

— Parts Side —

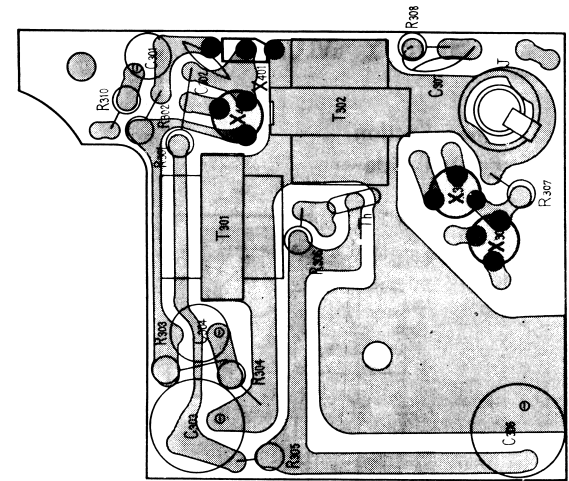

AF Section

— Printed Side —

