

"TRADER" SERVICE SHEET
1009

KOLSTER-BRANDES ER30

Covering also the FG20 autoradiogram and the radio unit in the FT50 TV receiver

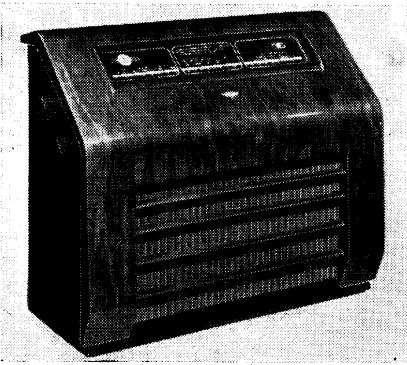

The appearance of the Kolster-Brandes ER30 table model.

tifier) 3-band superhet designed to operate from A.C. mains of 200-250 V, 50-100 c/s. The waveband ranges are 16.3-51.4 m, 187-585 m and 732-2,110 m.

Provision is made for the connection of a gramophone pick-up and an external speaker. The internal speaker can be muted, and the gramophone pick-up may be left permanently connected. The internal speaker is a 10-inch model.

The FG20 is a multi-speed autoradiogram employing an ER30 chassis, and the same chassis is used as the radio receiver in the FT50 television receiver.

Release dates and original prices: ER30, August 1949, £21 os 1d, increased February 1950 to £22 4s 5d, and February 1951 to £23 13s 8d, then April 1951 to £23 14s 6d; FG20, December 1950, £51 9s 7d, increased February 1951 to £55 3s 1d. Purchase tax extra.

(M.W.) and **L5, C29** (L.W.). On S.W., aerial input is inductively coupled via **L2** to single-tuned circuit **L3, C29**. **L1** and **R1** shunt the aerial circuit.

First valve (**V1, Brimar 6K8GT**) is a triode hexode operating as frequency changer with internal coupling. Oscillator grid coils **L6** (S.W.), **L7** (M.W.) and **L8** (L.W.) are tuned by **C30**. Parallel trimming by **C31** (S.W.), **C32** (M.W.) and **C33** (L.W.); series tracking by **C11** (M.W.) and **C9, C11** (L.W.). Inductive reaction coupling on S.W. by **L9**. Capacitive coupling on M.W. and L.W. across the common impedance of **C11** in grid and anode circuits.

Second valve (**V2, Brimar 7R7**) is a double diode R.F. pentode operating as signal detector and I.F. amplifier. The pentode section is coupled by tuned transformers **C4, L10, L11, C5** and **C13, L12, L13, C14**.

Intermediate frequency 465 kc/s.

Audio frequency output from diode signal is developed across the manual volume control **R14**, which acts as the diode load, and passed via coupling capacitor **C17** to

CIRCUIT DESCRIPTION

Aerial input on M.W. and L.W. is "bottom" coupled via capacitive potential divider comprising **C1** and **C2**, the effect of **L2** being negligible at these frequencies, to single-tuned circuits **L4, C29**

AN electronic variable tone control circuit is interposed in the A.F. amplifier of the Kolster-Brandes ER30, between the pre-amplifier and the output valve. The receiver is a 4-valve (plus rec-

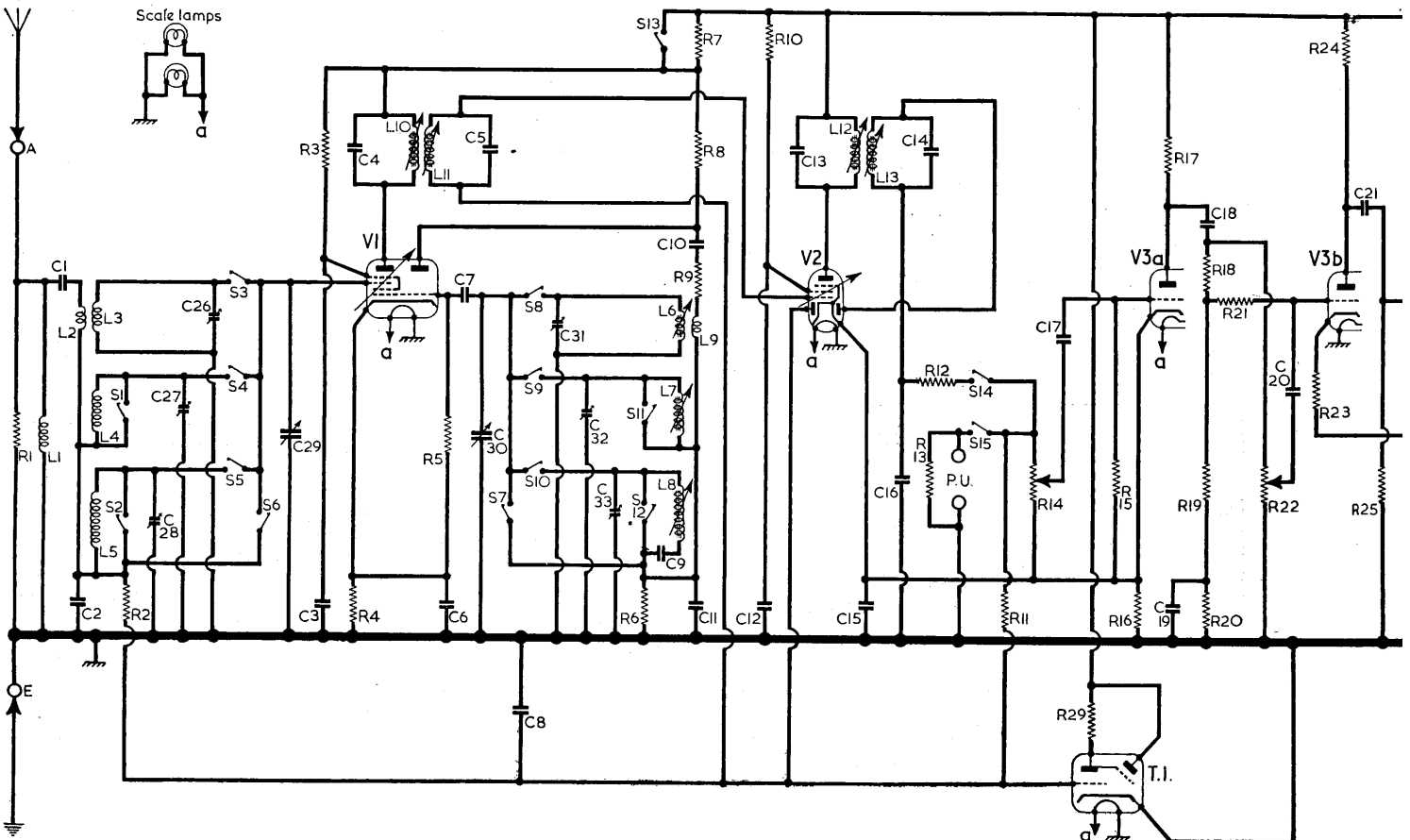

control grid of triode A.F. amplifier (V3a, one half of double triode valve, **Brimar 6SL7GT**), whose cathode circuit is common with that of V2.

Provision is made for the connection of a gramophone pick-up via S15 across R14. In addition to the change-over action of S14, S15, radio is muted on gram by the opening of S13, inserting R7 into the H.T. feed circuit to screen and both anodes of V1.

D.C. potential developed across R14 is tapped off and fed back via a decoupling circuit as grid bias to F.C. and I.F. valves, giving automatic gain control. The control grid of the cathode ray tuning indicator (T1, **Brimar 6U5G**) is connected to the A.G.C. line, so that its potential rises negatively as the incoming signal strength increases.

Resistance-capacitance coupling via electronic tone control circuit employing a second triode valve (V3b) between V3a and tetrode output valve (V4, **Brimar 6V6GT**). The output from V3a is developed across the potential divider C18, R18, R19, R20, C19 and fed to V3b control grid via R21 from a fixed position.

The output across the resistance arm, R18, R19, R20 appears also across R22, whose slider can tap off a variable amount of the signal across the arm and feed it via C20 to the control grid of V3b, modifying the frequency response of the coupling.

The overall response of V3b and V4 is further modified by output voltages from

T1 secondary winding fed back to V3b cathode circuit via the bias resistor R23, and by the introduction of C22 across V4 control grid circuit.

H.T. current is supplied by I.H.C. full-wave rectifying valve (V5, **Brimar 6X5GT**), with smoothing by electrolytic

capacitors C25, C23 and resistor R26. Residual hum is neutralized by passing the H.T. current through a section of the output transformer primary winding. A single secondary winding on the mains transformer T2 supplies all valve heaters, including the rectifier.

COMPONENTS AND VALUES

RESISTORS		Values	Locations
R1	Aerial shunt ...	4.7kΩ	G3
R2	A.G.C. decoupling	100kΩ	G3
R3	V1 S.G. feed ...	22kΩ	F2
R4	V1 G.B. ...	270Ω	F2
R5	V1 osc. C.G. ...	47kΩ	F3
R6	Osc. shunt ...	4.7kΩ	F3
R7	Radio muting ...	470kΩ	G2
R8	Osc. anode feed ...	33kΩ	F2
R9	Osc. stabilizer ...	100Ω	F3
R10	V2 S.G. feed ...	82kΩ	F2
R11	A.G.C. decoupling	2.2MΩ	F2
R12	I.F. stopper ...	47kΩ	E2
R13	P.U. shunt ...	220kΩ	F3
R14	Volume control ...	500kΩ	C1
R15	V3a C.G. ...	10MΩ	F2
R16	V2, V3a G.B. ...	100Ω	F3
R17	V3a anode load ...	220kΩ	E2
R18	Tone correctors ...	470kΩ	D2
R19		47kΩ	D2
R20		200kΩ	D2
R21		200kΩ	D2
R22	Tone control ...	500kΩ	D2
R23	V3b G.B. ...	4.7kΩ	E2
R24	V3b anode load ...	220kΩ	E2
R25	V4 C.G. ...	470kΩ	E3
R26	H.T. smoothing ...	1.5kΩ	E3
R27	T1 shunt ...	47kΩ	E2
R28	V4 G.B. ...	240Ω	E3
R29	T.I. anode feed ...	1MΩ	C1

CAPACITORS		Values	Locations
C1	Aerial coupling ...	0.005μF	G3
C2		0.003μF	G3
C3	V1 S.G. decoup. ...	0.02μF	F2
C4	1st I.F. trans. ...	200pF	A1
C5	tuning ...	200pF	A1
C6	V1 cath. by-pass ...	0.02μF	F3
C7	V1 osc. C.G. ...	100pF	F2
C8	A.G.C. decoup. ...	0.02μF	F2
C9	L.W. osc. tracker ...	200pF	F3
C10	Oscillator coupling	330pF	F3
C11		300pF	F3
C12	V2 S.G. decoup. ...	0.02μF	F2
C13	2nd I.F. trans. ...	200pF	B1
C14	tuning ...	200pF	B1
C15	Cathode by-pass ...	0.1μF	F2
C16	I.F. by-pass ...	100μF	F2
C17	A.F. coupling ...	0.005μF	F2
C18		0.01μF	E2
C19	Tone correctors ...	0.01μF	D2
C20		150pF	D2
C21	A.F. coupling ...	0.01μF	E3
C22	Tone corrector ...	50pF	E2
C23*	H.T. smoothing ...	32μF	D3
C24*	V4 cath. by-pass ...	25μF	E3
C25*	H.T. smoothing ...	32μF	D3
C26†	S.W. aerial trim. ...	40pF	G3
C27†	M.W. aerial trim. ...	40pF	G3
C28†	L.W. aerial trim. ...	40pF	G3
C29†	Aerial tuning ...	—	A1
C30†	Oscillator tuning ...	—	A1
C31†	S.W. osc. trimmer ...	40pF	G3
C32†	M.W. osc. trimmer ...	40pF	G3
C33†	L.W. osc. trimmer ...	80pF	G3

* Electrolytic. † Variable. ‡ Pre-set.

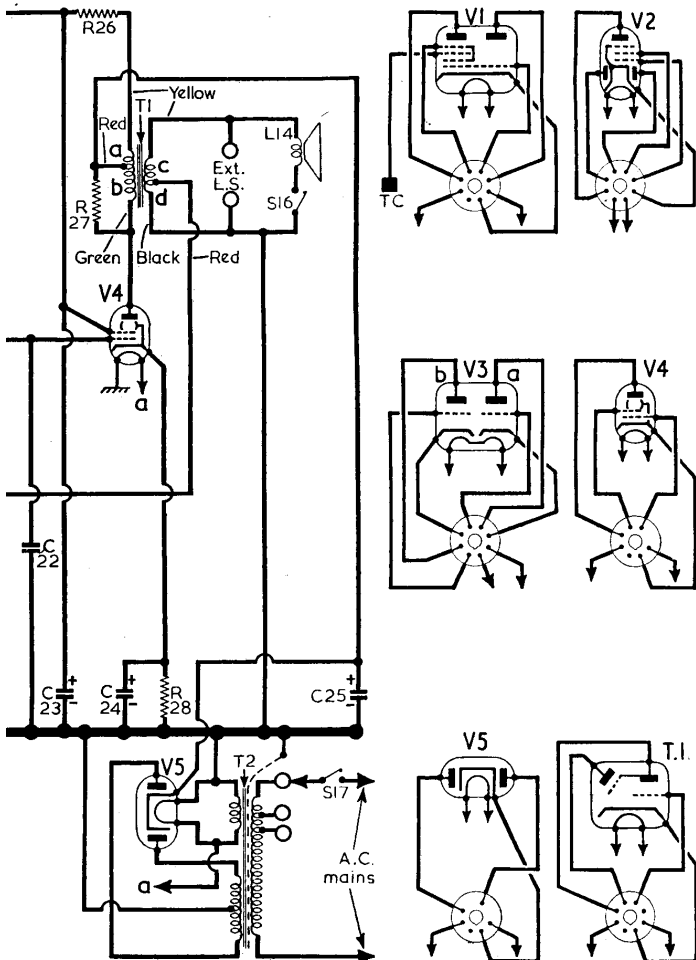

Circuit diagram of the K.-B. ER30. On M.W. and L.W. the aerial coupling consists of the potential divider formed by C1 and C2. V3a and V3b are two halves of a double triode valve, V3b, operating as an electronic tone control. In some models the cathodes of V2 and V3a go directly to chassis, and R16 and C15 are omitted. C22 also may be omitted. This circuit diagram applies also to the FG20 autoradio-gram and to the FT50 television broadcast radio receiver.

OTHER COMPONENTS		Values	Locations
L1	Mod. hum filter ...	16.0	G3
L2	S.W. aerial coup. ...	—	G3
L3	Aerial tuning coils ...	—	G3
L4		3.0	G3
L5		20.0	G3
L6		—	F3
L7	Oscillator tuning coils ...	3.0	F3
L8		8.0	F3
L9	S.W. reaction coil ...	—	F3
L10	1st I.F. trans. {Pri.	3.5	A1
L11		{Sec.	3.5
L12	2nd I.F. trans. {Pri.	4.5	B1
L13		{Sec.	3.5
L14	Speech coil ...	—	—
T1	a ...	13.0	—
	b ...	450.0	E3
	c ...	—	—
	d ...	—	—
T2	Primary (total) ...	45.0	—
	H.T. sec., (total) ...	580.0	C1
	Htr. secondary ...	0.3	—
S1-S15	Waveband switches	—	G2
S16	Speaker switch ...	—	—
S17	Mains sw., g'd R22	—	D2

Dealers are reminded that the component numbers used in the above tables may be different from those in the makers' circuit diagram. If our component numbers are used, therefore, when ordering spares, it is advisable to mention the fact.

Waveband Switch Diagrams and Table

Switches	Gram	L.W.	M.W.	S.W.
S1	—	C	—	—
S2	—	—	C	—
S3	—	—	—	C
S4	—	—	C	C
S5	—	C	—	—
S6	C	—	—	—
S7	C	—	—	—
S8	—	—	—	C
S9	—	—	C	—
S10	—	C	—	—
S11	—	C	—	—
S12	—	—	C	C
S13	—	C	C	C
S14	—	C	—	—
S15	C	—	—	—

VALVE ANALYSIS

Valve voltages and currents given in the table below are those measured on our receiver when it was operating from A.C. mains of 230V, with the voltage adjustment set appropriately. The set was tuned to the high wavelength end of M.W. and the volume control turned to maximum, but there was no signal input.

Voltage readings were taken with an Avo Electronic Testmeter, and as it draws no appreciable current, allowance must be made for the current drawn by other meters. Chassis was the negative connection.

The target voltage on the cathode ray tuning indicator was 220V, and that on the triode anode 11V. This latter rises to about 40V upon the arrival of a signal.

Valves	Anode		Screen		Cath.
	V	mA	V	mA	
V1 6K8GT	210	2.7	135	5.0	3.2
	Oscillator				
V2 7R7	88	3.2	110	1.3	0.65
	210	3.7			
V3	80	0.5	—	—	0.65
6SL7GT {a	130	0.37	—	—	—
V4 6V6GT	230	34.0	210	3.5	9.4
V5 6X5GT	236†	—	—	—	245.0

† A.C. volts, each anode.

GENERAL NOTES

Switches.—S1-S12 are the waveband switches, and S13-S15 are the radio/gram change-over switches, ganged in two rotary units beneath the chassis. These units are indicated in our underside draw-

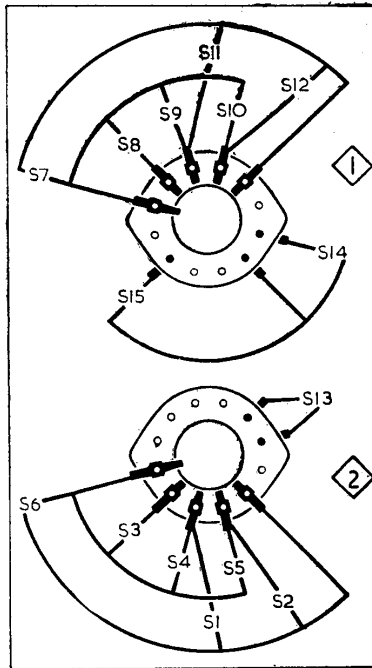

Diagrams of the waveband switch units, drawn as seen when viewed in the directions of the arrows in our underside view of the chassis. On the left is the associated switch table.

ing of the chassis, where they are identified by the numbers 1 and 2 in diamond surrounds.

The diagrams (above) show these units in detail. They are drawn as seen when viewed in an inverted chassis in the directions of the arrows in the under-chassis view. The table in col. 1 gives the switch positions for the four control settings, starting from the fully anti-clockwise position of the control knob. A dash indicates open, and C, closed.

S16 is a screw-type switch for muting the internal speaker. It is mounted on a panel carrying the external speaker sockets on the back cover of the receiver.

S17 is the Q.M.B. mains switch, ganged with the tone control R22.

Scale Lamps.—These are two M.E.S. type lamps, with clear tubular bulbs, rated at 6.5V, 0.3A.

External Speaker.—Two sockets are provided on the back cover of the receiver for the connection of a low impedance (about 2-4Ω) external speaker. Between them is a screw-type switch S16 by which the internal speaker may be muted. A pair of leads from this panel goes to two sockets on the chassis.

These sockets are connected internally to the internal speaker, one of them being connected also to the tap on the output transformer secondary. The other is returned to chassis, but it does so via the external speaker panel and S16. The rest of its path to chassis is via the earth lead on the A and E socket panel.

Because of this circuit arrangement the internal speaker speech coil is open-circuited if the plugs to the back cover are removed, and the internal speaker will be inoperative unless the earthy socket is temporarily connected to chassis.

It is important when inserting the plugs from the back cover into the Ext. L.S. sockets on the chassis to get them the right way round: the green lead should go into the left-hand socket, and the yellow lead into the right-hand socket. In our under-chassis view these colours are not indicated. They would, of course, be reversed because the chassis is inverted.

DISMANTLING THE SET

Removing Chassis.—Pull off four control knobs and remove four cheese-head screws (with washers) securing chassis to cabinet;

withdraw chassis to extent of speaker leads and unsolder them from the speech coil tags.

Removing Speaker.—Withdraw the four cheese-head screws (with lock washers) securing the speaker to the sub-baffle, and lift it out.

When replacing, the speech coil tags should be at the bottom.

DRIVE CORD REPLACEMENT

About five feet of nylon braided glass yarn is required for a new drive cord, which should be run as shown in our sketch in cols. 4 and 5, where the system is drawn as seen from the front right-hand corner of the chassis, neglecting obstructions, when the gang is at maximum capacitance.

A keyhole-shaped aperture near the right-hand scale lamp, with a slot at the top, will register exactly with the large (central) cursor with the gang at maximum when the cursor assembly is properly adjusted, but to see this the cursor must be viewed directly from the front. A second similar keyhole registers with the same cursor when the gang is at minimum capacitance.

The best way to fit the cord is first to make a non-slip loop about 1/2 in diameter at one end, slip it over the right-hand cursor, and wax it to hold it in position temporarily on the horizontal bar.

Then, holding the cursor assembly roughly in the maximum position, make a trial run of the cord past the right-hand pulley, round the control spindle 3 1/2 times, and so on to the gang drum, running round it until the point is reached where the cord meets the tension spring, with the gang at maximum.

Now fold the cord back on itself and form it into a slip-knot loop that will hold

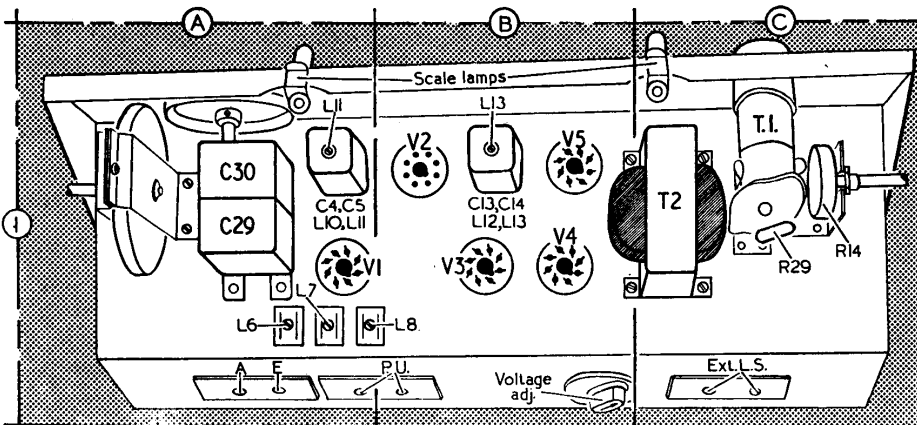

Plan view of the chassis, showing the socket panels at the rear for aerial, pick-up and external speaker connections, which go to a second set of sockets on the back cover. Until these latter are connected the internal speaker is open-circuited.

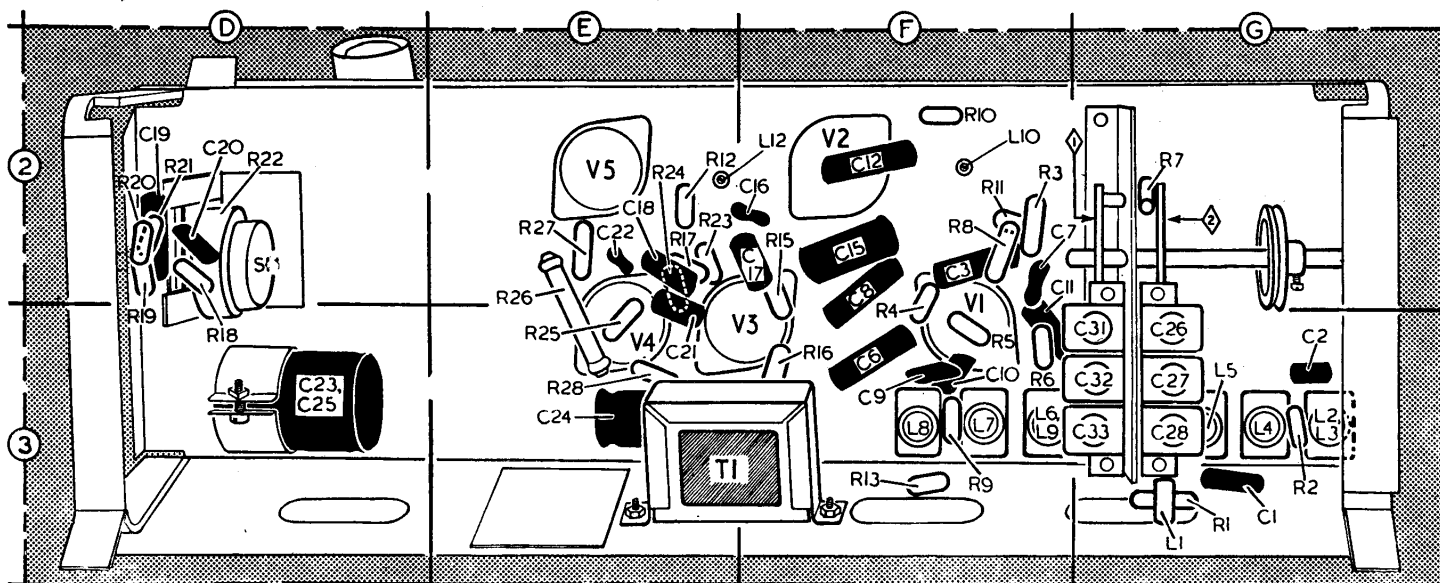

Underside view of the chassis. The components associated with the tone control circuit are grouped around the variable element **R22** on the left. The unreadable switch number ganged with **R22** should be **S17**. The aerial shunt coil **L1** is wound on its associated resistor **R1**. Diagrams of the waveband switch units, coded 1 and 2 in diamond surrounds, appear at the head of col. 2.

it on to the tension spring securely. The cord will inevitably have come adrift from the drum during this process, but it need be held no longer; neither need the cursor assembly be held. The tension spring can be hooked in position, and the other half of the cord can be run, starting from the tension spring and pulling against the gang stop at maximum.

Finally, re-run the first length back to the starting point at the cursor, and tie off the second length to the loop on the first, as shown in the sketch, winding it round the cursor bar a turn or so en route, and fix the joins with wax.

A considerable range of coarse adjustment can be obtained by sliding the loop along the bar, and an adequate range of fine adjustment is then available by turning the drum on the gang spindle.

CIRCUIT ALIGNMENT

I.F. Stages.—Connect output of signal generator, via a 0.1μF capacitor in the "live" lead, to control grid (top cap) of **V1** and chassis. Switch set to M.W., turn volume control to maximum and gang to minimum. Feed in a 465kc/s

(645.16m) signal and adjust the cores of **L13** (location reference B1), **L12** (E2), **L11** (A1) and **L10** (F2) for maximum output, reducing the input as the circuits come into line to reduce A.G.C. effects. Repeat these adjustments.

R.F. and Oscillator Stages.—Since the glass tuning scale is mounted in the cabinet, and alignment adjustments have to be carried out with the chassis on the bench, a series of calibration marks are printed on the front of the scale backing plate, and readings are made against the long centre cursor. As these calibration marks have been omitted in some models, including ours, the exact positions of the marks with respect to the datum line, and the wavelengths they represent, are indicated in our drawing in col. 6 and can be pencilled in on the scale backing plate where necessary.

With the gang at maximum capacitance the cursor should coincide with the datum line, and any error may be corrected by rotating the drive drum on its spindle, after slackening the two grub screws. Transfer "live" signal generator lead, via a suitable dummy aerial, to aerial socket.

M.W.—With set switched to M.W. tune to 500m line on scale backing plate, feed in a 500m (600kc/s) signal and adjust the core of **L7** (A1) for maximum output. Tune set to 214m line, feed in a 214m (1,400kc/s) signal and adjust **C32** (G3) and **C27** (G3) for maximum output. Repeat these adjustments.

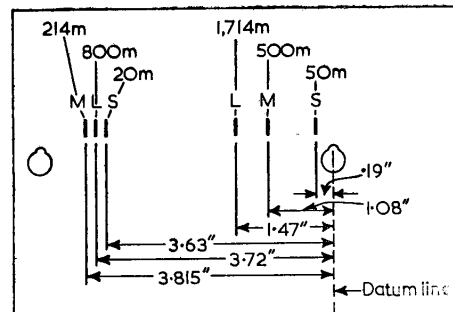

Sketch showing a section of the scale backing plate, viewed from the front. Exact distances are shown from an imaginary datum line drawn through the centre of the right-hand keyhole opening for the six cursor settings for the alignment procedure. None of the markings shown actually existed in our receiver.

L.W.—Switch set to L.W., tune to 1,714m line, feed in a 1,714m (175kc/s) signal and adjust the core of **L8** (A1) for maximum output. Tune set to 860m line (800m line in drawing), feed in an 860m (350kc/s) signal and adjust **C33** (G3) and **C28** (G3) for maximum output. Repeat these adjustments.

S.W.—Switch set to S.W., tune to 50m line, feed in a 50m signal and adjust the core of **L6** (A1) for maximum output. Tune set to 20m line, feed in a 20m (15Mc/s) signal and adjust **C31** (G3) and **C26** (G3) for maximum output. Repeat these adjustments.

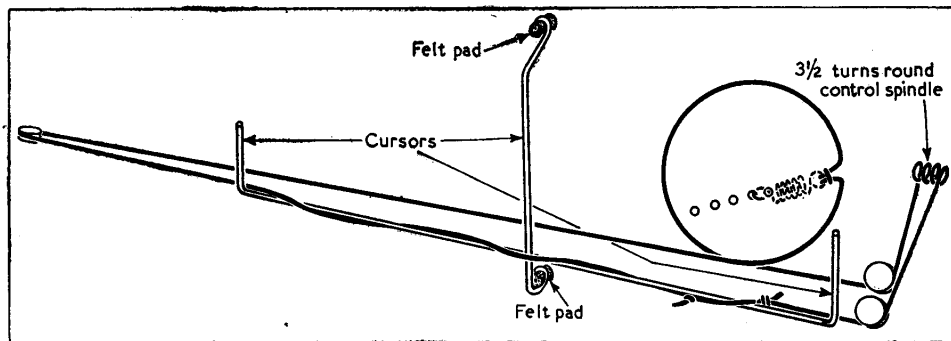

Sketch of the tuning drive system, drawn as seen when viewed from the front right-hand corner of the chassis when the gang is at maximum capacitance. The scale backing plate is assumed to be transparent.