

28.7.83.

HX-2
HX-3

AKAI SERVICE MANUAL

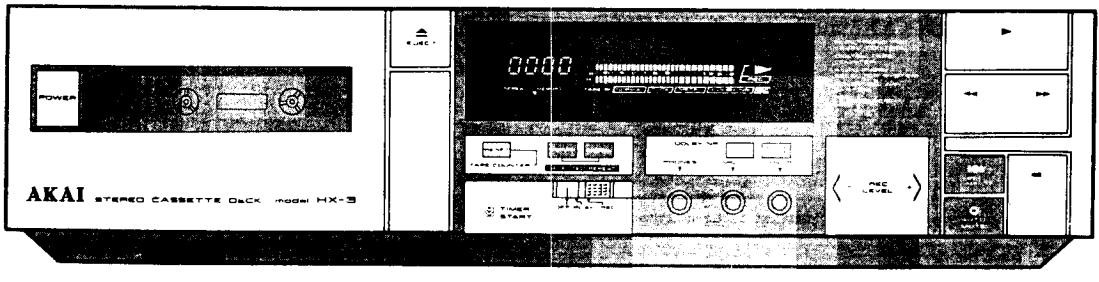
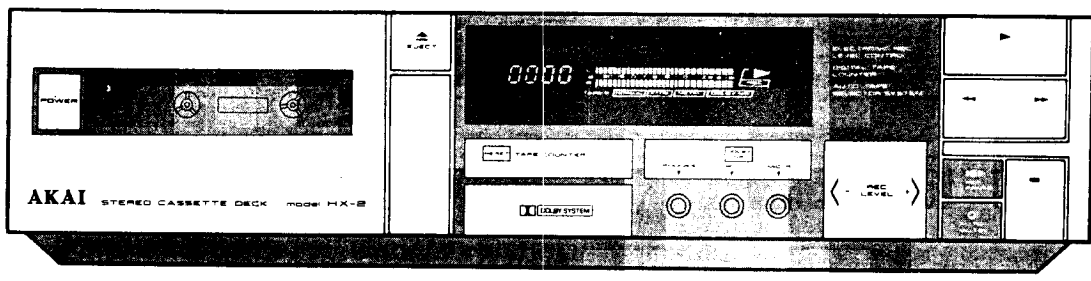

STEREO CASSETTE DECK

MODEL **HX-2**

MODEL **HX-3**

**ABBREVIATIONS FOR SERVICE MANUAL
MODEL HX-2/HX-3**

ABBREVIATIONS	EXPLANATION
AC	Alternating Current
CONT	CONTrol
DET	DETECT
EQ	EQUALizer
F	FORward
F.F	Fast Forward
H.P	Head Phone
INV	INVerter
MICOM	MICro-COMputer
NR	Noise Reduction
NF	Negative Feedback
OSC	OSCillator
P.B	Play Back
REC	RECORDing
REW	REWind
R	Reverse
SW	SWitch
T.U	Take Up (Reel)

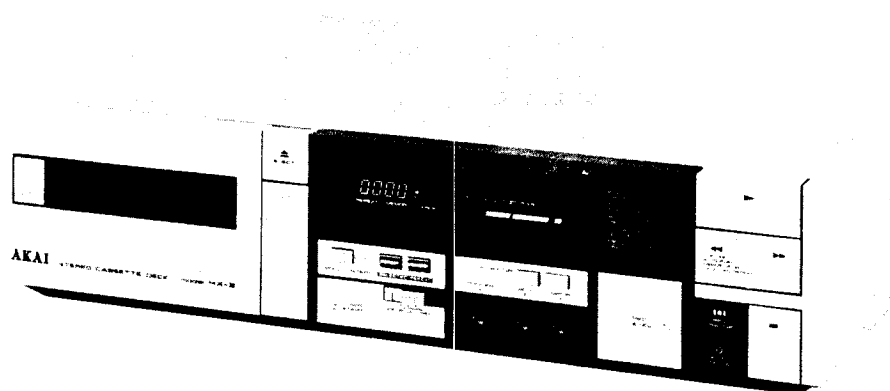
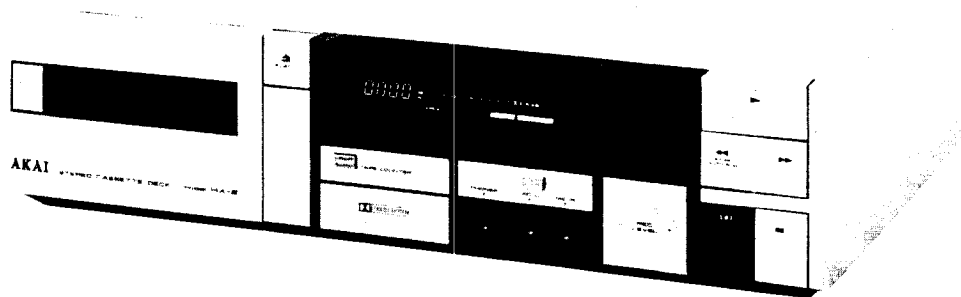

STEREO CASSETTE DECK

MODEL **HX-2**

MODEL **HX-3**

SECTION 1	SERVICE MANUAL.....	3
SECTION 2	PARTS LIST.....	33
SECTION 3	SCHEMATIC DIAGRAM.....	49

SAFETY INSTRUCTIONS

SAFETY CHECK AFTER SERVICING

Confirm the specified insulation resistance between power cord plug prongs and externally exposed parts of the set is greater than 10 Mohms, but for equipment with external antenna terminals (tuner, receiver, etc.) and is intended for [C] or [A], specified insulation resistance should be more than 2.2 Mohms (ground terminals, microphone jacks, headphone jacks, line-in out jacks etc.).

PRECAUTIONS DURING SERVICING

1. Parts identified by the Δ symbol parts are critical for safety.
Replace only with parts number specified.
2. In addition to safety, other parts and assemblies are specified for conformance with such regulations as those applying to spurious radiation. These must also be replaced only with specified replacements.
Examples: RF converters, tuner units, antenna selector switches, RF cables, noise blocking capacitors, noise blocking filters, etc.
3. Use specified internal wiring. Note especially:
 - 1) Wires covered with PVC tubing
 - 2) Double insulated wires
 - 3) High voltage leads
4. Use specified insulating materials for hazardous live parts. Note especially:
 - 1) Insulation Tape
 - 2) PVC tubing
 - 3) Spacers (Insulating Barriers)
 - 4) Insulation sheets for transistors
 - 5) Plastic screws for fixing microswitch (especially in turntable)
5. When replacing AC primary side components (transformers, power cords, noise blocking capacitors, etc.), wrap ends of wires securely about the terminals before soldering.

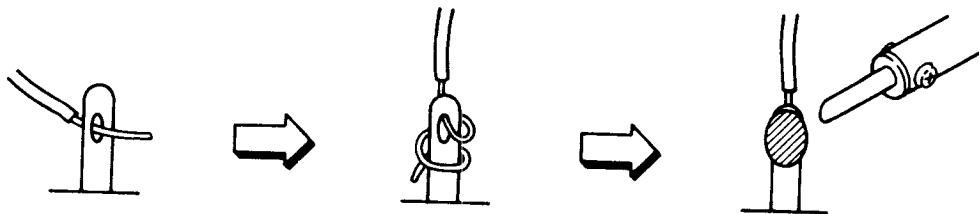

6. Observe that wires do not contact heat producing parts (heatsinks, oxide metal film resistors, fusible resistors, etc.).
7. Check that replaced wires do not contact sharp edged or pointed parts.
8. Also check areas surrounding repaired locations.
9. Use care that foreign objects (screws, solder droplets, etc.) do not remain inside the set.
10. Voltage Conversion
 - 1) Models for Canada, USA, Europe, UK and Australia are not equipped with this facility. Each machine is preset at the factory according to destination, but some machines can be set to 110V, 120V, 220V or 240V as required.
If your machine's voltage can be converted:
 - 1-1) Disconnect power cord.
 - 1-2) Turn the VOLTAGE SELECTOR located on the rear panel with a screwdriver until the correct voltage is indicated.

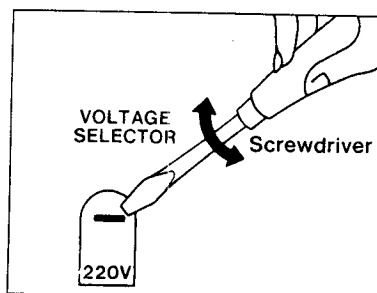

11. Cycle Conversion

Cycle conversion is not necessary since HX-2 and HX-3 uses DC motors.

SECTION 1

SERVICE MANUAL

TABLE OF CONTENTS

I.	SPECIFICATION	4
II.	DISMANTLING OF UNIT	6
III.	CONTROLS	7
IV.	PRINCIPAL PARTS LOCATION	9
V.	MECHANICAL DESCRIPTION PART FOR EACH MODE	11
	1. MOTOR AND BELT	11
	2. REWIND OPERATION	11
	3. FAST FORWARD OPERATION	12
	4. FORWARD (PLAY) OPERATION	12
VI.	DESCRIPTION OF CIRCUIT OPERATION	14
	1. SYSCON BLOCK DIAGRAM	14
	2. HX-2 PRE-AMP BLOCK DIAGRAM	15
	3. HX-3 PRE-AMP BLOCK DIAGRAM	15
	4. ACTIONS OF SYSTEM CONTROL IC LM6405-145	16
VII.	MECHANICAL ADJUSTMENTS	17
	1. VARIOUS TORQUE MEASUREMENT	17
	2. REC/P.B HEAD AZIMUTH ALIGNMENT	17
	3. TAPE SPEED ADJUSTMENT	17
VIII.	AMPLIFIER ADJUSTMENT	18
	1. PRE-AMPLIFIER ADJUSTMENT POINT MODEL HX-2	18
	2. PRE-AMPLIFIER ADJUSTMENT POINT MODEL HX-3	20
IX.	DC RESISTANCE OF VARIOUS COILS	22
X.	CLASSIFICATION OF VARIOUS P.C BOARD	22

I. SPECIFICATION

1-1 MODEL HX-2

Track system	4 Track 2 channel stereo system
Tape	Philips type cassette
Heads	Erase head × 1 High density head for recording/playback × 1
Motor	Electronically speed controlled DC motor for capstan drive × 1
Wow & Flutter	0.12% (DIN) 0.05% (WRMS)
Frequency response	Normal: 20 to 15,000Hz ± 3dB CrO ₂ : 20 to 16,000Hz ± 3dB Metal: 20 to 17,000Hz ± 3dB
S/N	56dB (Measured via tape with peak recording level) Dolby NR Switch ON: Improves up to 5dB at 1kHz 10dB above 5kHz
Distortion	0.7% (METAL)
Input	Line: 70mV/47kohms Mic: 0.25mV/5kohms
Output	Line: 410mV/1kohms Phones: 0.3mW/8ohms
Power consumption	U.A.C Models: 13W
Power requirements	120V 60Hz for USA and Canada 220V 50Hz for Europe except UK 240V, 50Hz for UK and Australia 110V/120V/220V/240V, 50/60Hz switchable for other countries
Dimensions	440 (W) × 103 (H) × 280 (D) mm (17.3 × 4.1 × 11.0 inches)
Weight	4.0Kg (8.8 lbs)

* For improvement purposes, specifications and design are subject to change without notice.

* Noise reduction manufactured under license from Dolby Laboratories Licensing Corporation. "Dolby" and the double-D symbol are trade marks of Dolby Laboratories Licensing Corporation.

1-1 MODEL HX-3

Track System	4 Track 2 channel stereo system
Tape	Philips type cassette
Heads	Erase head × 1 High density head for recording/playback × 1
Motor	Electronically speed controlled DC motor for capstan drive × 1
Wow & Flutter	0.12% (DIN) 0.05% (WRMS)
Frequency Response	Normal: 20 to 16,000Hz ± 3dB CrO ₂ : 20 to 17,000Hz ± 3dB Metal: 20 to 18,000Hz ± 3dB
S/N	56dB (Measured via tape with peak recording level) Dolby B-type NR Switch ON: Improves up to 5dB at 1kHz 10dB above 5kHz Dolby C-type NR Switch ON: Improves up to 15dB at 500kHz 20dB at 1kHz to 10kHz
Distortion	0.7% (METAL)
Input	Line: 70mV/47kohms Mic: 0.25mV/5kohms
Output	Line: 410mV/1kohms Phones: 0.3mW/8ohms
Power Consumption	U.A.C Models: 14W
Power requirements	120V 60Hz for USA and Canada 220V 50Hz for Europe except UK 240V, 50Hz for UK and Australia 110V/120V/220V/240V, 50/60Hz switchable for other countries
Dimensions	440 (W) × 103 (H) × 280 (D) mm (17.3 × 4.1 × 11.0 inches)
Weight	4.0Kg (8.8 lbs)

* For improvement purposes, specifications and design are subject to change without notice.

* Noise reduction manufactured under license from Dolby Laboratories Licensing Corporation. "Dolby" and the double-D symbol are trade marks of Dolby Laboratories Licensing Corporation.

II. DISMANTLING OF UNIT

In case of trouble, etc. necessitating dismantling, please dismantle in the order shown in the photographs. Reassemble in reverse order.

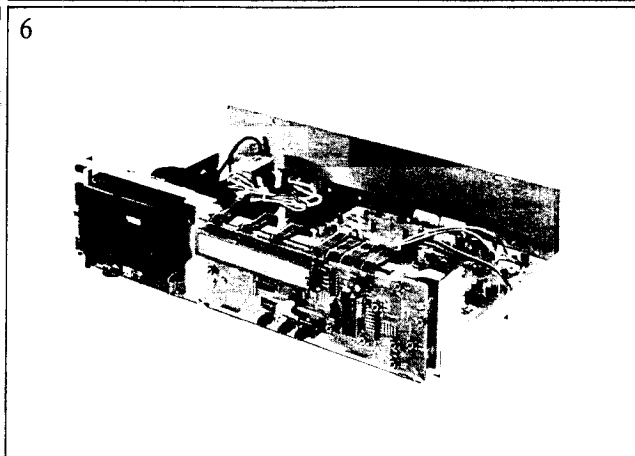
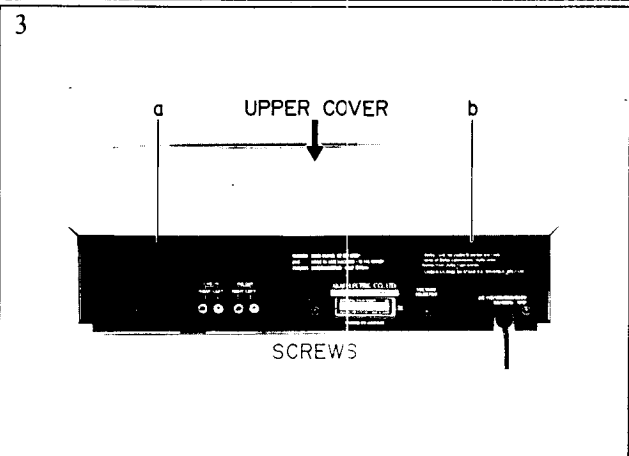
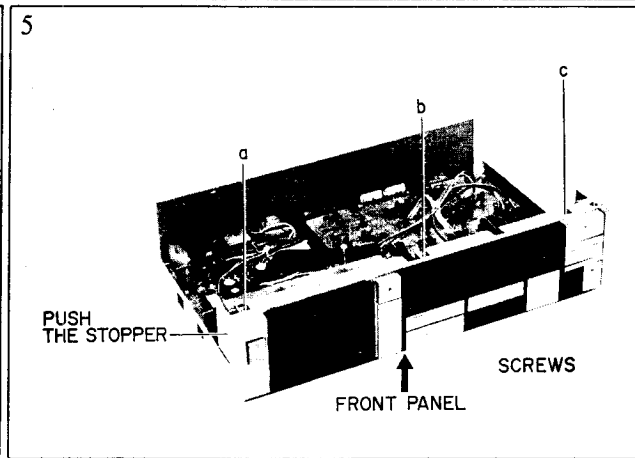
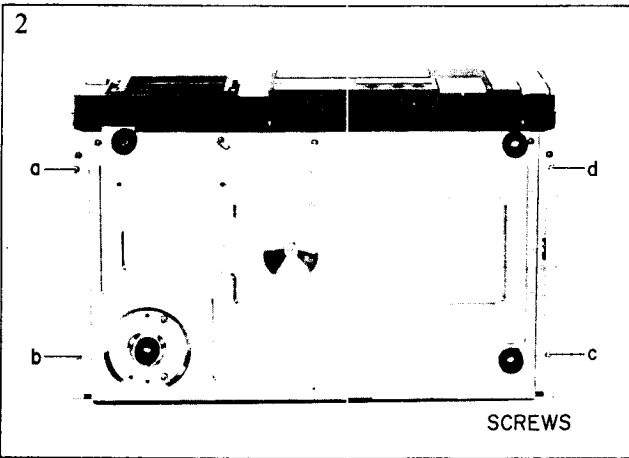
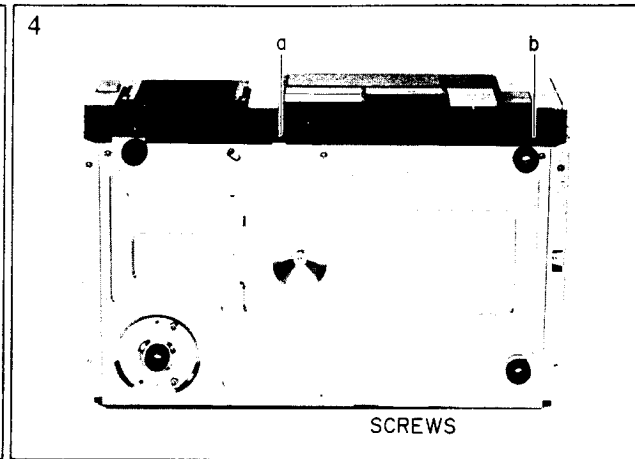
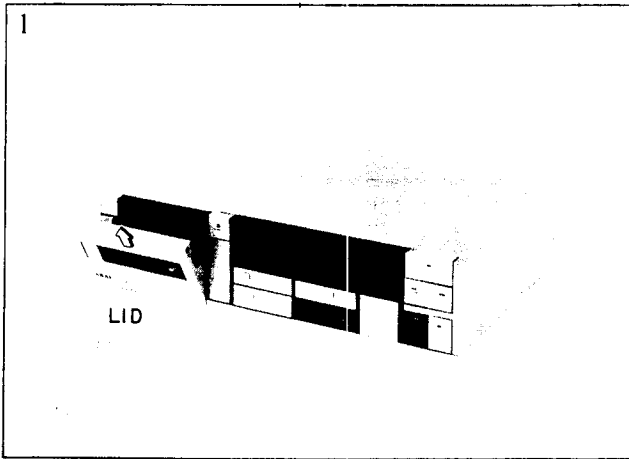

III. CONTROLS

3-1 MODEL HX-2

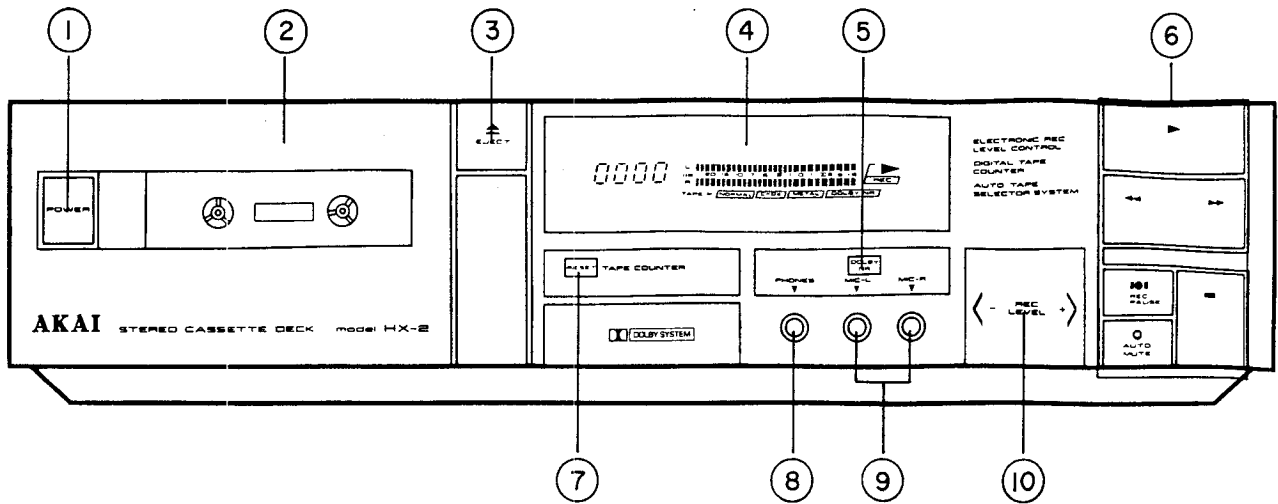

Fig. 3-1 Front View

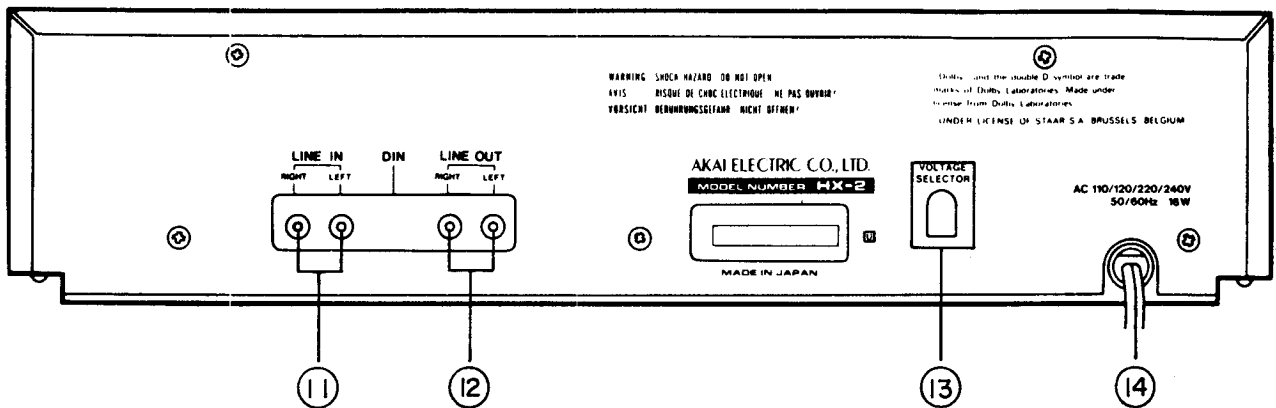

Fig. 3-2 Rear View

- | | |
|------------------------------|-------------------------------------|
| 1. POWER SWITCH | 8. PHONES JACK |
| 2. CASSETTE HOLDER | 9. MIC JACKS (L/R) |
| 3. EJECT BUTTON | 10. REC LEVEL CONTROL |
| 4. FL DISPLAY | 11. LINE IN JACKS |
| 5. DOLBY NR SWITCH | 12. LINE OUT JACKS |
| 6. OPERATION BUTTONS | 13. VOLTAGE SELECTOR (U) model only |
| 7. TAPE COUNTER RESET BUTTON | 14. AC POWER CORD |

3-2 MODEL HX-3

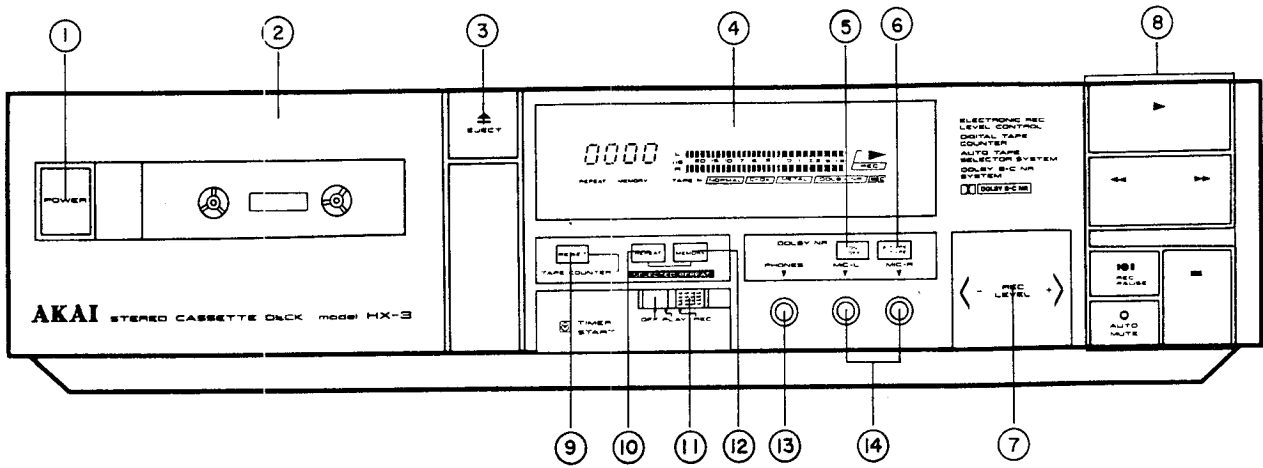

Fig. 3-3 Front View

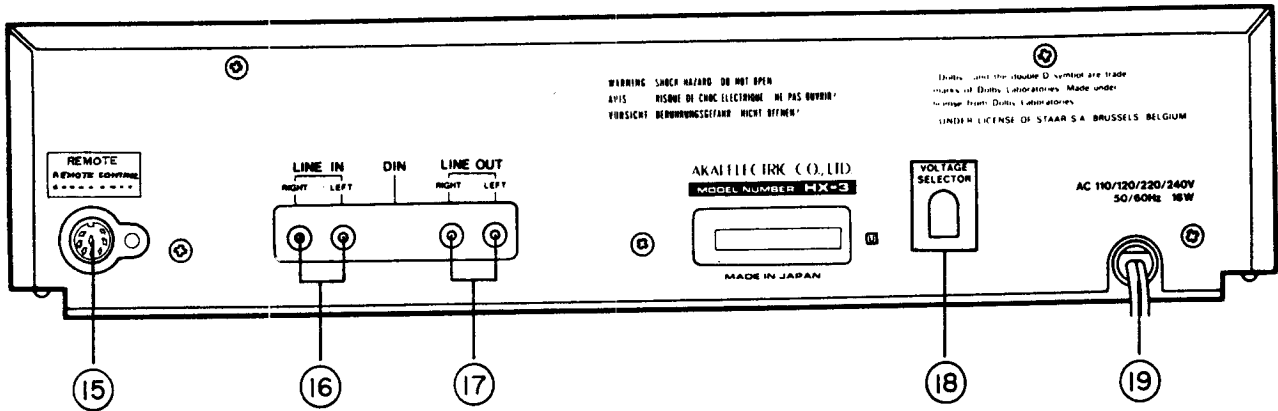

Fig. 3-4 Rear View

- | | |
|------------------------------|---|
| 1. POWER SWITCH | 11. TIMER START SELECTOR (OFF/PLAY/REC) |
| 2. CASSETTE HOLDER | 12. MEMORY BUTTON |
| 3. EJECT BUTTON | 13. PHONES JACK |
| 4. FL DISPLAY | 14. MIC JACKS (L/R) |
| 5. DOLBY NR ON/OFF SWITCH | 15. REMOTE CONTROL |
| 6. DOLBY B/C SELECTOR SWITCH | 16. LINE IN JACKS |
| 7. REC LEVEL CONTROL | 17. LINE OUT JACKS |
| 8. OPERATION BUTTON | 18. VOLTAGE SELECTOR (U) model only |
| 9. TAPE COUNTER RESET BUTTON | 19. AC POWER CORD |
| 10. REPEAT BUTTON | |

IV. PRINCIPAL PARTS LOCATIONS

4-1 MODEL HX-2

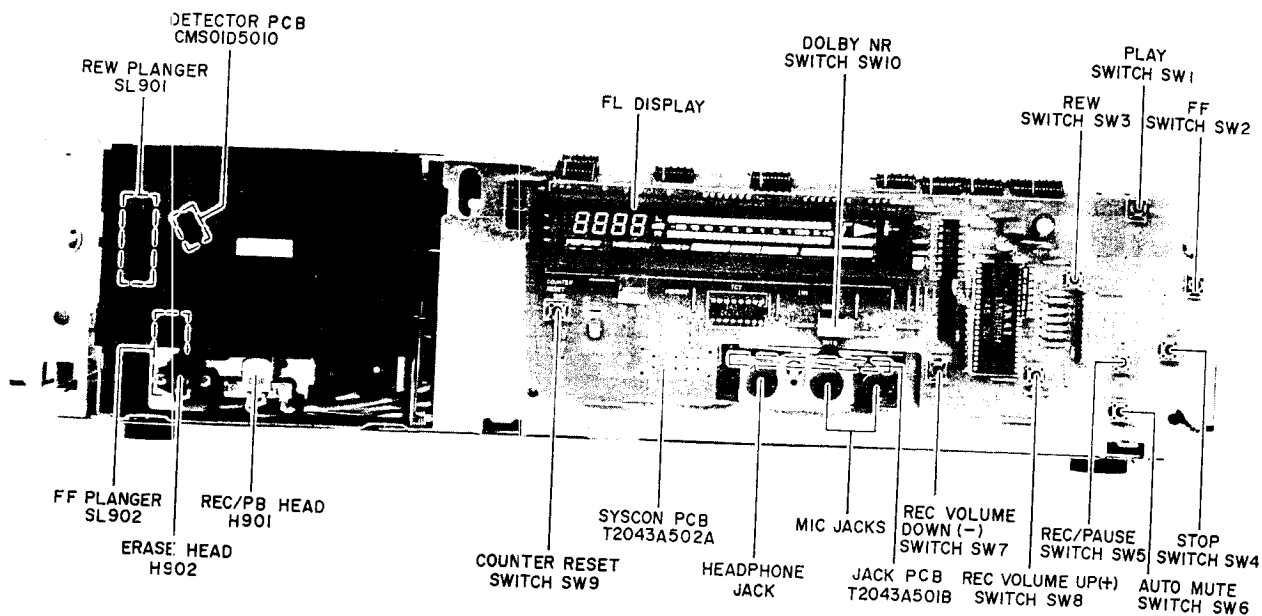

Fig. 4-1 Front View

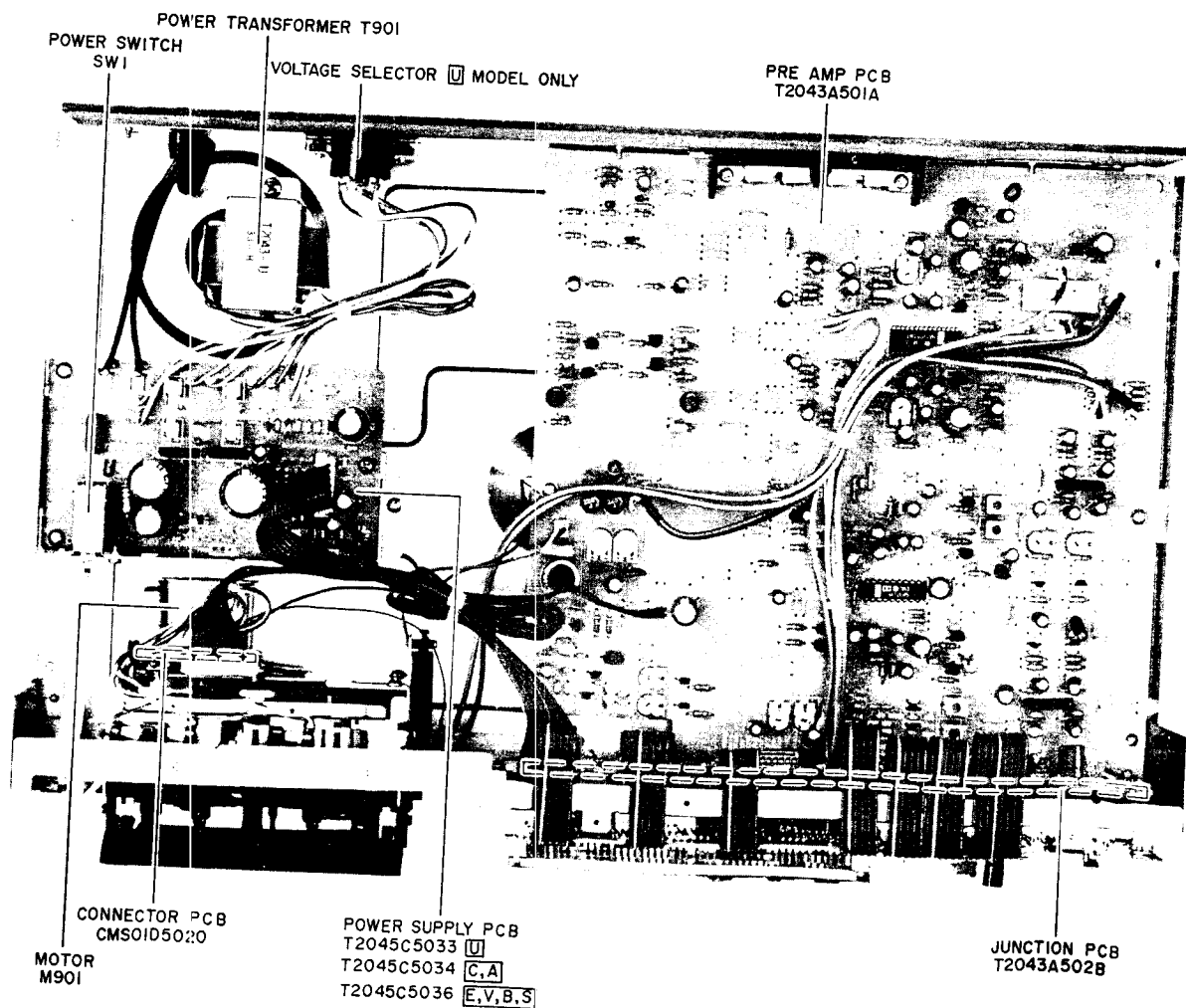

Fig. 4-2 Top View

4-2. MODEL HX-3

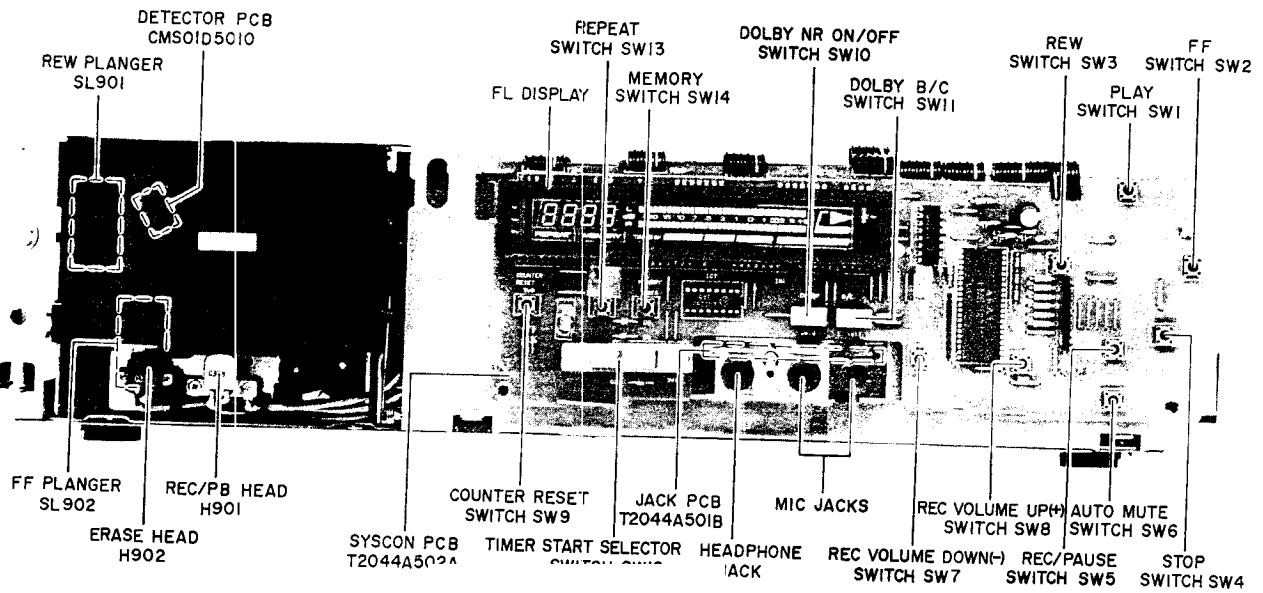

Fig. 4-3 Front View

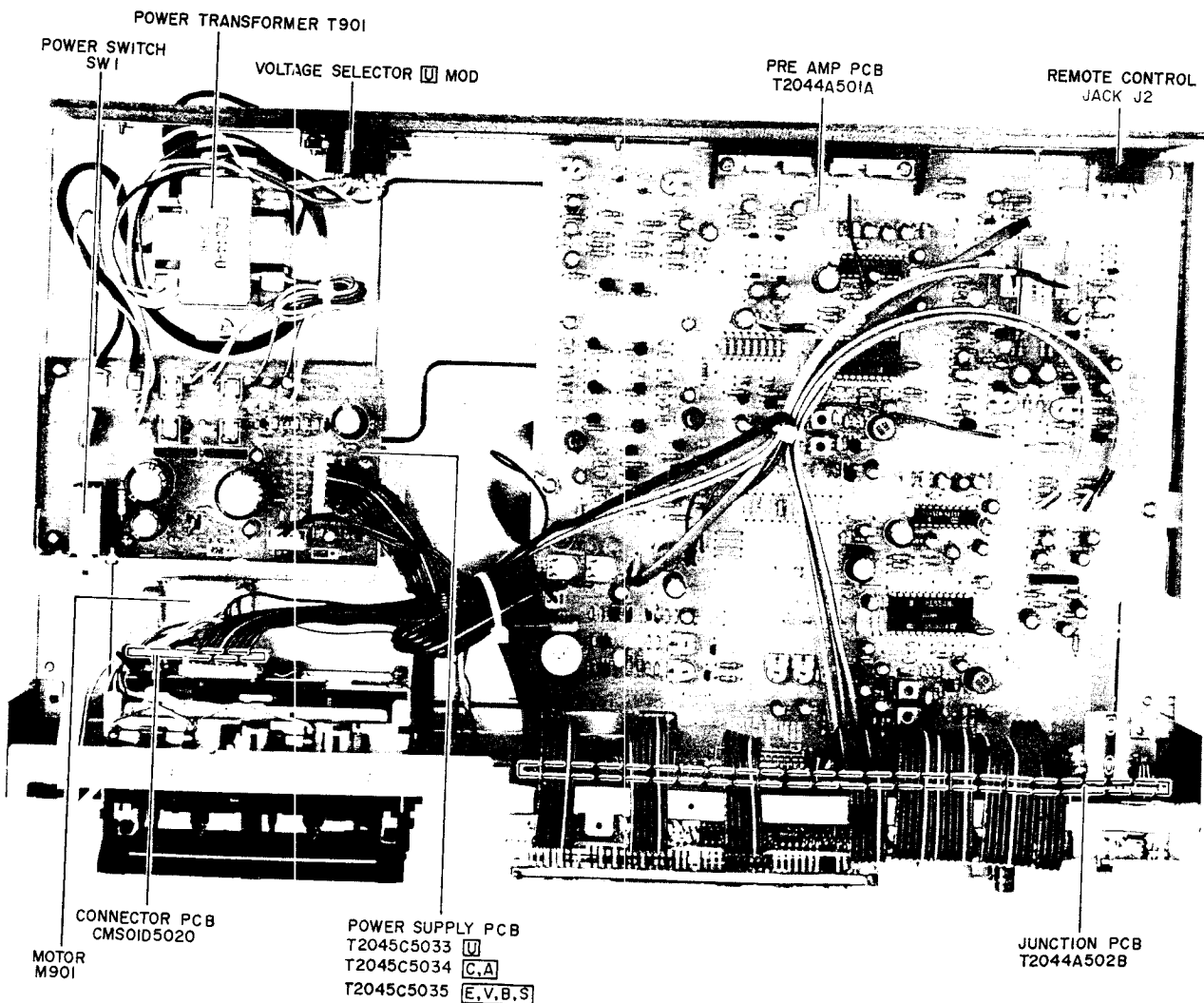

Fig. 4-4 Top View

V. MECHANICAL DESCRIPTION PART FOR EACH MODE

5-1. MOTOR AND BELT (Refer to Fig. 5-1)

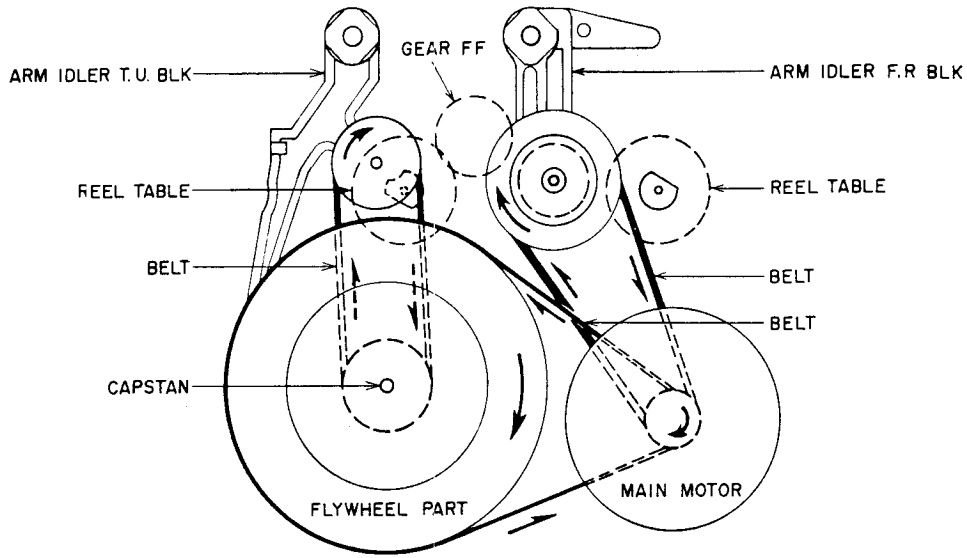

Fig. 5-1 Motor and Belt

When the power switch is turned ON to energize and rotate the main motor, the rotation is transferred through two driving belts to the flywheel and idler F.R. The flywheel rotation is transferred to Idler T.U. through a belt. The rotation of the flywheel and idlers operates the main rotation system of the cassette mechanical block.

A

Ti

5-2. REWIND OPERATION (Refer to Fig. 5-2)

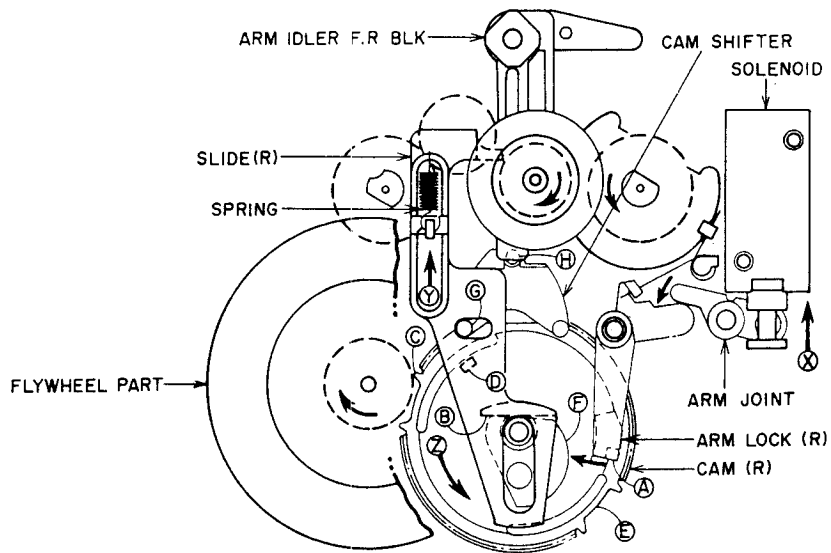

Fig. 5-2 Rewind Operation

When the REW button is pressed the solenoid core is pulled in the $\otimes \rightarrow$ mark direction. The operation unlocks the \textcircled{A} part of the arm lock (R) through the arm joint. The unlocked cam (R) is given the rotating trigger in the direction of $\textcircled{Z} \rightarrow$ mark by the \textcircled{B} part of the slide (R) which is pushed down in the direction of $\textcircled{Y} \rightarrow$ mark by spring force. This engages the gear of \textcircled{C} part and the rotation of the flywheel gear is transferred to the cam (R). The rotation of this cam (R) is stopped by the stopper \textcircled{D} and then the \textcircled{E} part moves to the position of the flywheel gear and the gear is disengaged to stop the rotation of the cam (R).

In the rotation of the cam (R) from the engagement of \textcircled{C} round to section \textcircled{E} , the \textcircled{B} part is raised by the \textcircled{F} cam, and therefore, when the gear disengaged, the slide (R) is raised in the reverse $\textcircled{Y} \rightarrow$ direction thus raising the \textcircled{H} pin of the cam shifter to swing the \textcircled{H} pin toward the right.

This swing is used to swing the arm of the idler F.R. to the right to engage the reel table gear thus transferring the REW rotation to the reel table.

5-3. FAST FORWARD OPERATION (Refer to Fig. 5-3)

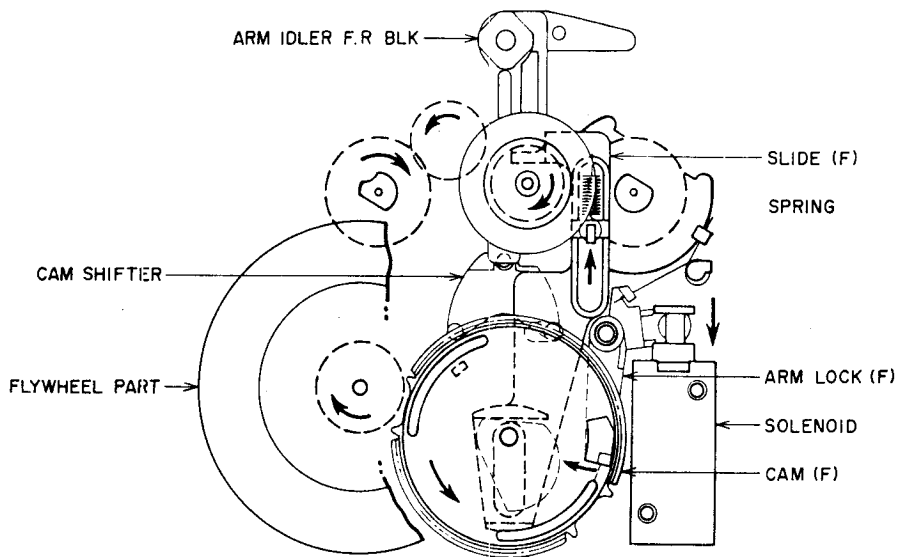

Fig. 5-3 Fast Forward Operation

The fast forward operation is basically almost the same as the rewind operation. The cam shifter is raised at the right side by the slide (F) to swing the arm idler F.R. to the left so that it engages the reel table gear, thus transferring the fast forward rotation.

The fast forward rotation is continued by means of the fast forward solenoid and is stopped when the solenoid is "OFF".

5-4. FORWARD (PLAY) OPERATION (Refer to Figs. 5-4, 5-5 and 5-6)

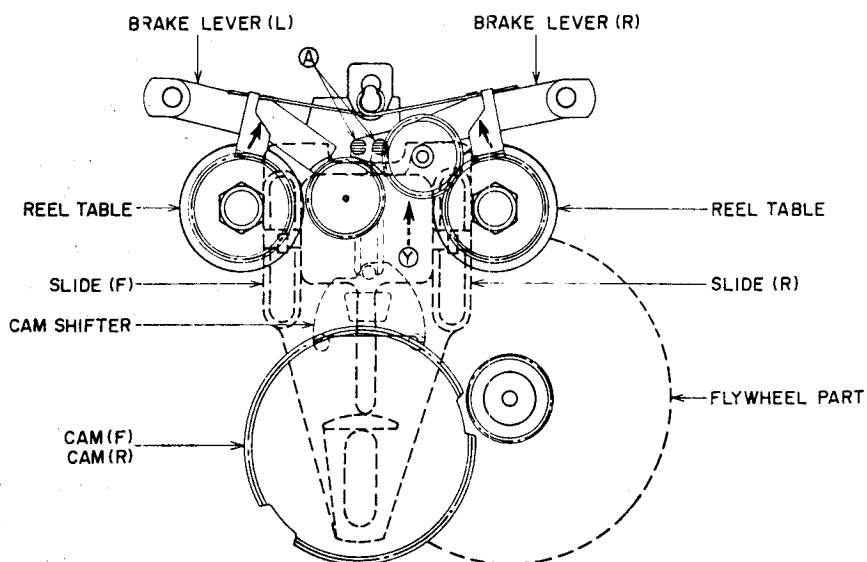

Fig. 5-4 Forward (PLAY) Operation

When the PLAY button is pressed, two solenoids are energized, both arm locks (F) and (R) are unlocked, both cams (F) and (R) rotate simultaneously and both slides (R) and (F) are forced to slide upwards in the direction of the $\text{Y} \rightarrow$ mark. Then the cam shifter also moves in parallel with this movement.

The pin A is moved with the movement of the slide by means of the brake lever to remove the brake from the reel table.

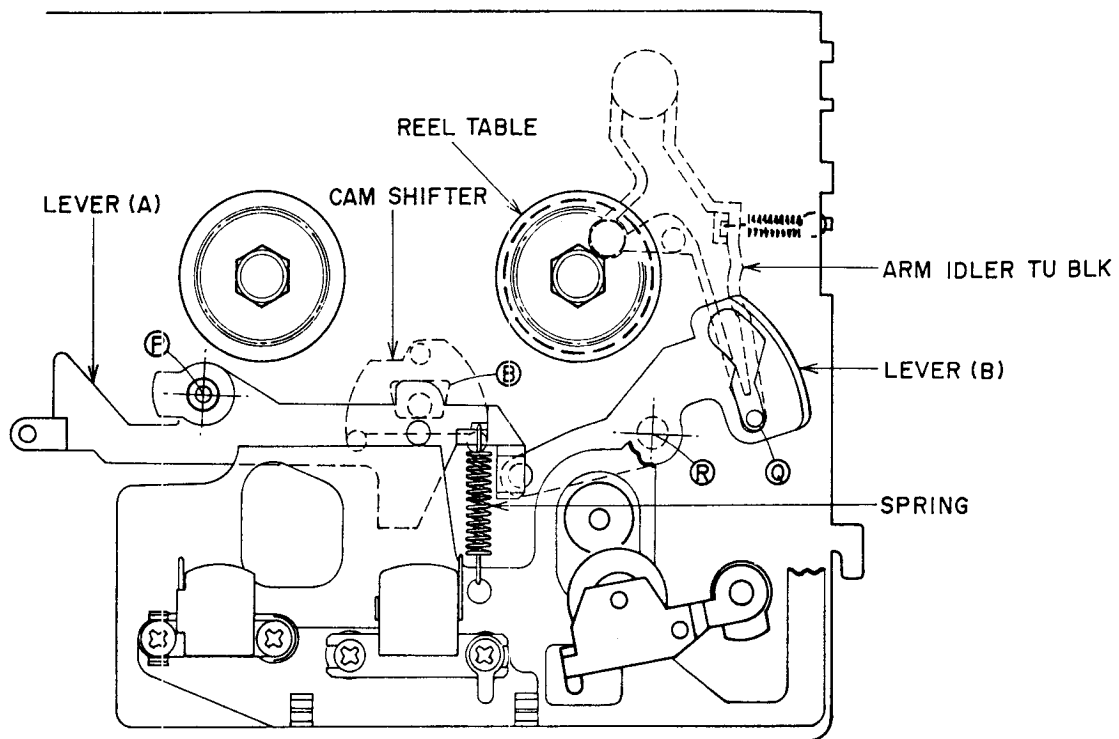

Fig. 5-5 STOP Mode

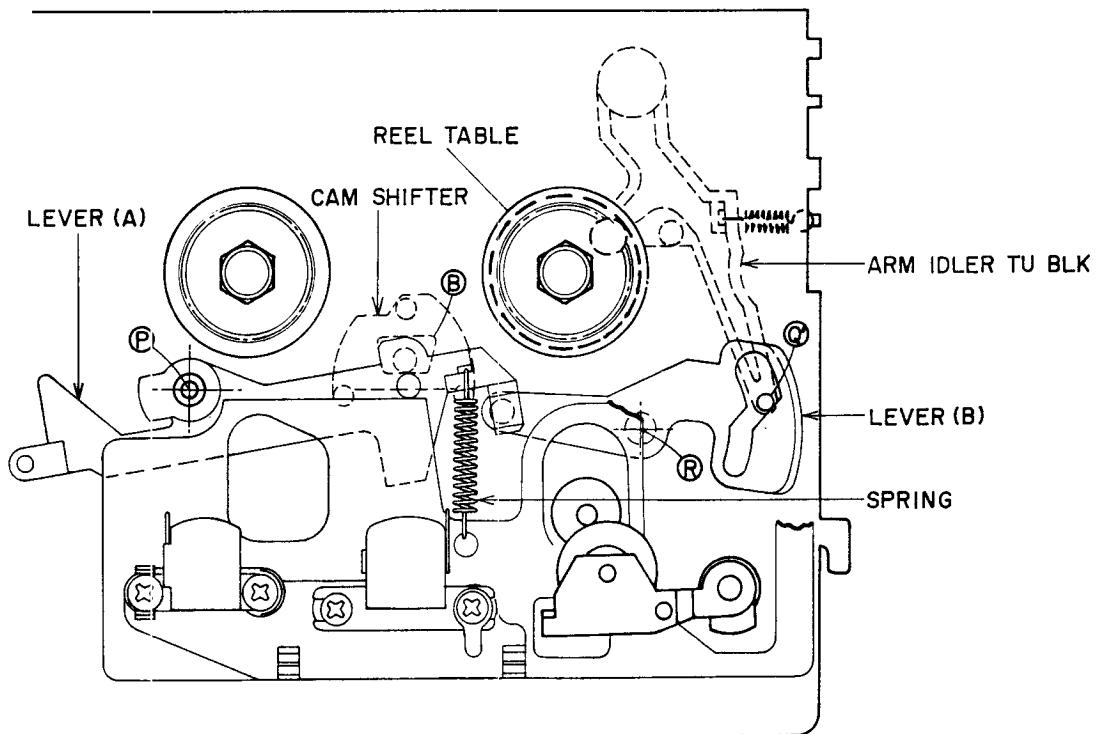

Fig. 5-6 PLAY Mode

A round pin of the lever (A) is inserted in the ⊗ shaped hole of the cam shifter to achieve interlock, and the lever (B) is engaged in the slot of the lever (A) to achieve interlock.

When the cam shifter is forced to slide upwards in the PLAY mode, the lever (A) engaged with it moves upwards round the fulcrum ⊗ as the fixed center, to raise the head chassis by means of the force provided by the spring. The lever (B) engaged with the lever (A) rotates

the fulcrum ⊗ as the fixed center to place the pin ⊗ in the ⊗ position and transfers the rotation by pressing the rubber pulley of the idler TU against the inside surface of the reel table.

(The rotation of the idler TU is transferred from the fly-wheel by means of the belt.)

When the head chassis slides upwards the pinch roller is pressed against the capstan by the torsion spring.

VI. DESCRIPTION OF CIRCUIT OPERATION

6-1. SYSCON BLOCK DIAGRAM (Refer to Fig. 6-1)

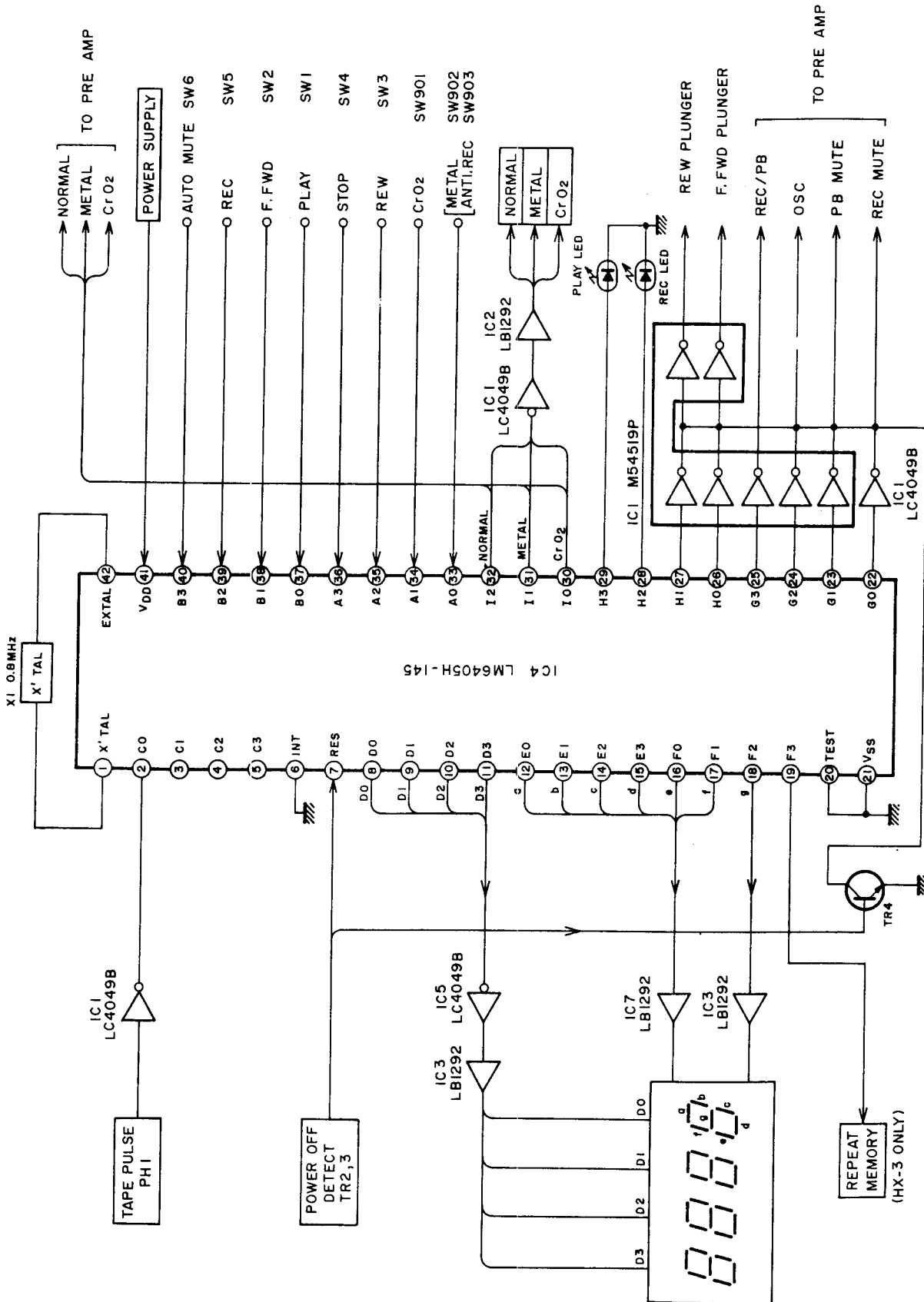

6-2. HX-2 PRE-AMP BLOCK DIAGRAM (Refer to Fig. 6-2)

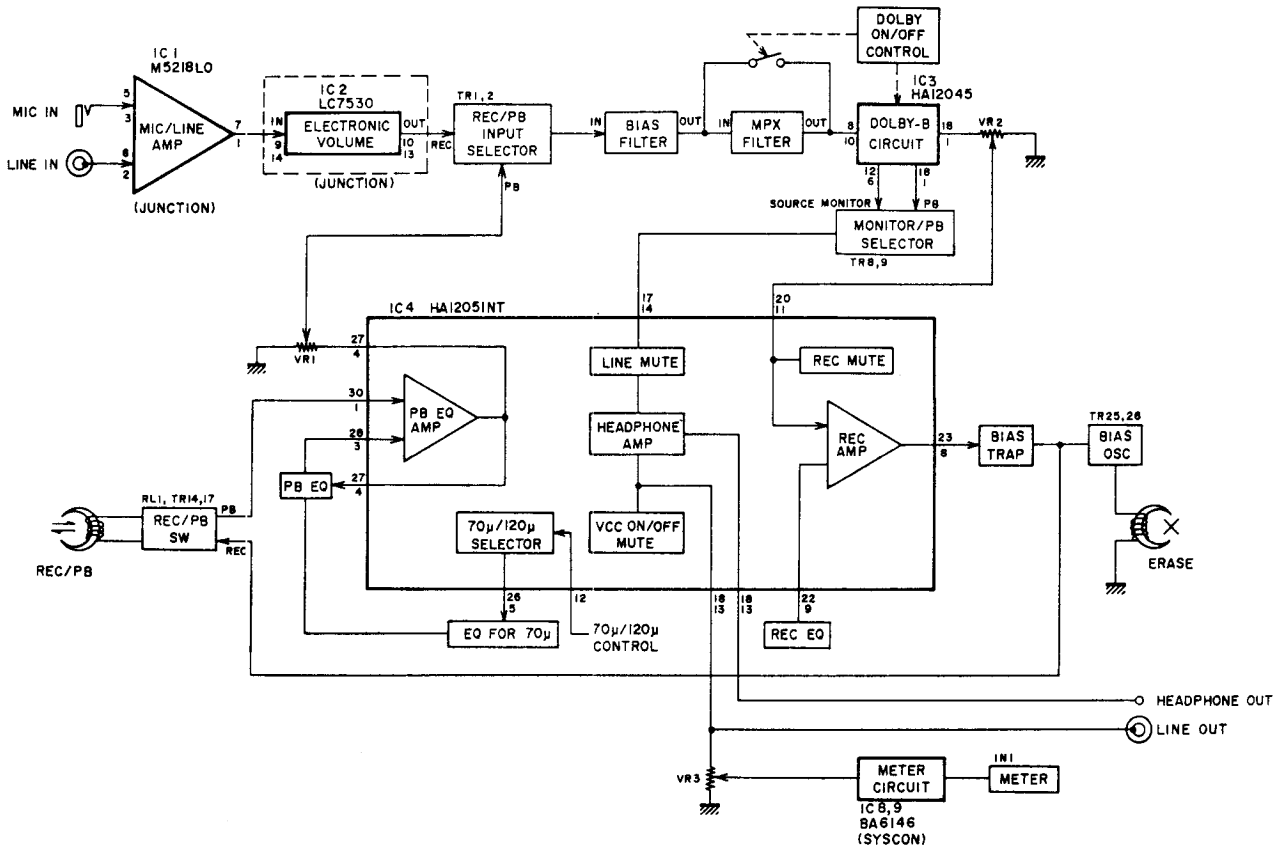

Fig. 6-2 Pre-Amp Block Diagram HX-2

6-3. HX-3 PRE-AMP BLOCK DIAGRAM (Refer to Fig. 6-3)

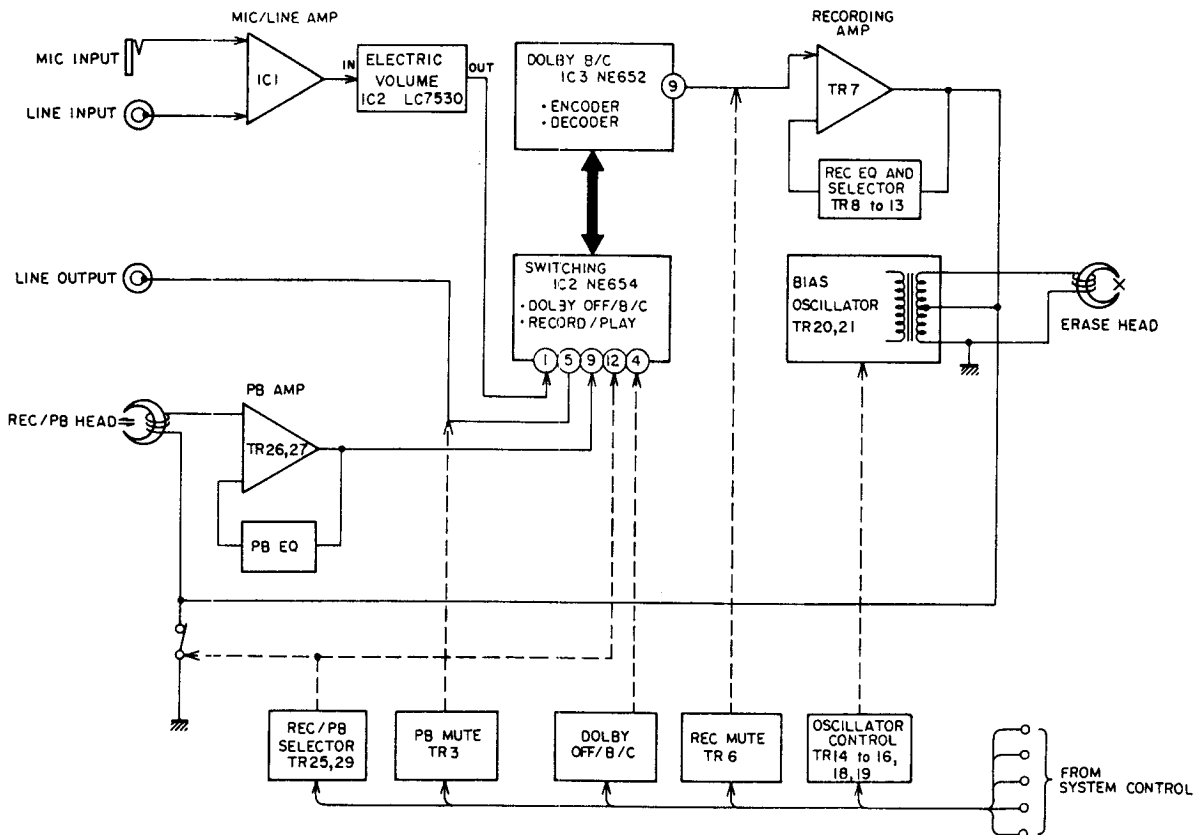

Fig. 6-3 Pre-Amp Block Diagram HX-3

6-4. ACTIONS OF SYSTEM CONTROL IC LM 6405-145

SYSCON MYCOM (IC LM6405H-145)

Pin No.	Symbol	Meaning	
1	XTAL	Crystal oscillator input	
2	C0	Tape Pulse Input	
3	C1	×	
4	C2	×	
5	C3	×	
6	<u>INT</u>	Interrupting terminal:	
7	<u>RES</u>	Reset terminal:	
8	D0	} DIGIT DRIVE (4-digit)	
9	D1		
10	D2		
11	D3		
12	E0	} 7 Segments LED DRIVE a	
13	E1		b
14	E2		c
15	E3		d
16	F0		e
17	F1		f
18	F2		g
19	F3	Strobe signal for operation indicator LED DRIVE (HX-3 only)	
20	TEST	} To "GND"	
21	V _{SS}		
22	G0	REC MUTE terminal:	
23	G1	PB MUTE terminal:	
24	G2	BIAS OSC control terminal:	
25	G3	REC/PB switching terminal:	
26	H0	PLUNGER (R)	
27	H1	PLUNGER (F)	
28	H2	REC LED terminal:	
29	H3	PB LED terminal:	
30	I0	} TAPE SELECTOR switching terminal	
31	I1		
32	I2		
33	A0	MEMORY, *TIMER REC, T.S.IN *METAL, REC DETECTION (A.R)	
34	A1	*REPEAT, *TIMER PLAY, T.S.IN CrO ₂ , COUNTER RESET	
35	A2	Key input REW	
36	A3	STOP	
37	B0	PLAY	
38	B1	FF	
39	B2	REC	
40	B3	AUTO MUTE	
41	V _{DD}	+5V	
42	EXTAL	Crystal oscillator input	

1) ACTION OF FF AND RWD PLUNGERS

The FF and REW plungers are controlled by the "HIGH" and "LOW" signals at Pin 26 and 27 of IC4 (LM6405-145), and the "ON" and "OFF" operation of the FF and REW plungers activates the mechanical operation of each mode.

* The plunger is activated by the "LOW" control signal from IC4 (LM6405-145) pins 26 and 27.

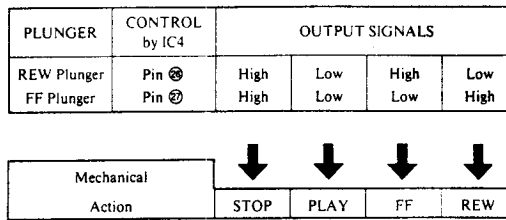

Fig. 6-4 Tape Selector Operation

2) TAPE SELECTOR OPERATION

When a cassette tape is inserted and the switches SW901 and SW902 are turned ON or OFF, the signal combination as shown in Fig. 6-5 will be input through Pins 33 and 34 of the IC4 (LM6405-145). Through the combination of "LOW" and "HIGH" at these input pins 33 and 34, the signals to control the REC equalizer, bias voltage, etc. will be output from IC4 (LM6405-145) as shown in Fig. 6-6.

Each POSITION lights at "L" output

* In Pin Nos. 33 and 34, same as in other switch inputs, when the switch is pressed, the input to Micro Computer is switched from "H" level to "L" level.

[Input]	
T.S. IN METAL	T.S. IN CrO ₂
Pin No.	Pin No.
(33)	(34)
L	L
L	H
H	H
H	L

Fig. 6-5 Input

	[Output]		
	Pin No. (30)	Pin No. (31)	Pin No. (32)
NORMAL	H	H	L
CrO ₂	L	H	H
METAL	H	L	H
	H	L	H

Fig. 6-6 Output

VII. MECHANICAL ADJUSTMENTS

7-1 VARIOUS TORQUE MEASUREMENT

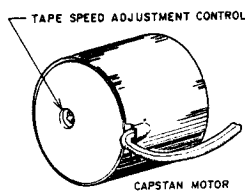

Fig. 7-1 Tape Speed Adjustment

Use the Cassette Torque Meter (AJ-751179) to confirm that the value of each mode is as follows:

- Take up Torque: 25 to 60 g-cm
- Back Tension Torque: 2 to 5 g-cm
- F.F./REW Torque: 70 to 120 g-cm

7-2 REC/P.B HEAD AZIMUTH ALIGNMENT

(Refer to Fig. 7-2)

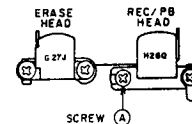

Fig. 7-2 Top View of the Heads

Playback a 10 kHz Azimuth Alignment tape (AT-750778) and adjust the screw (A) until the output levels of both channels are maximum.

After adjustment, paintlock the screw (A).

7-3 TAPE SPEED ADJUSTMENT

(Refer to Fig. 7-1)

Connect a frequency counter to line output terminals. Playback a 1,000 Hz Tape Speed Test tape (AT-750774) or a 3,150 Hz Tape Speed Test tape (AT-751263) and adjust a tape speed adjustment volume (see Fig. 7-1) to obtain a tape speed of 1,000 Hz \pm 1.0%, or 3,150 Hz \pm 1.0%.

Notes:

1. Be sure to clean the heads prior to head adjustment.
2. Be careful not to use a magnetized driver or other magnetized tools in the vicinity of the heads.
3. Be sure to demagnetize the heads with a Head Demagnetizer before and after head adjustment.

VIII. AMPLIFIER ADJUSTMENTS

8-1 PRE-AMPLIFIER ADJUSTMENT POINT MODEL HX-2

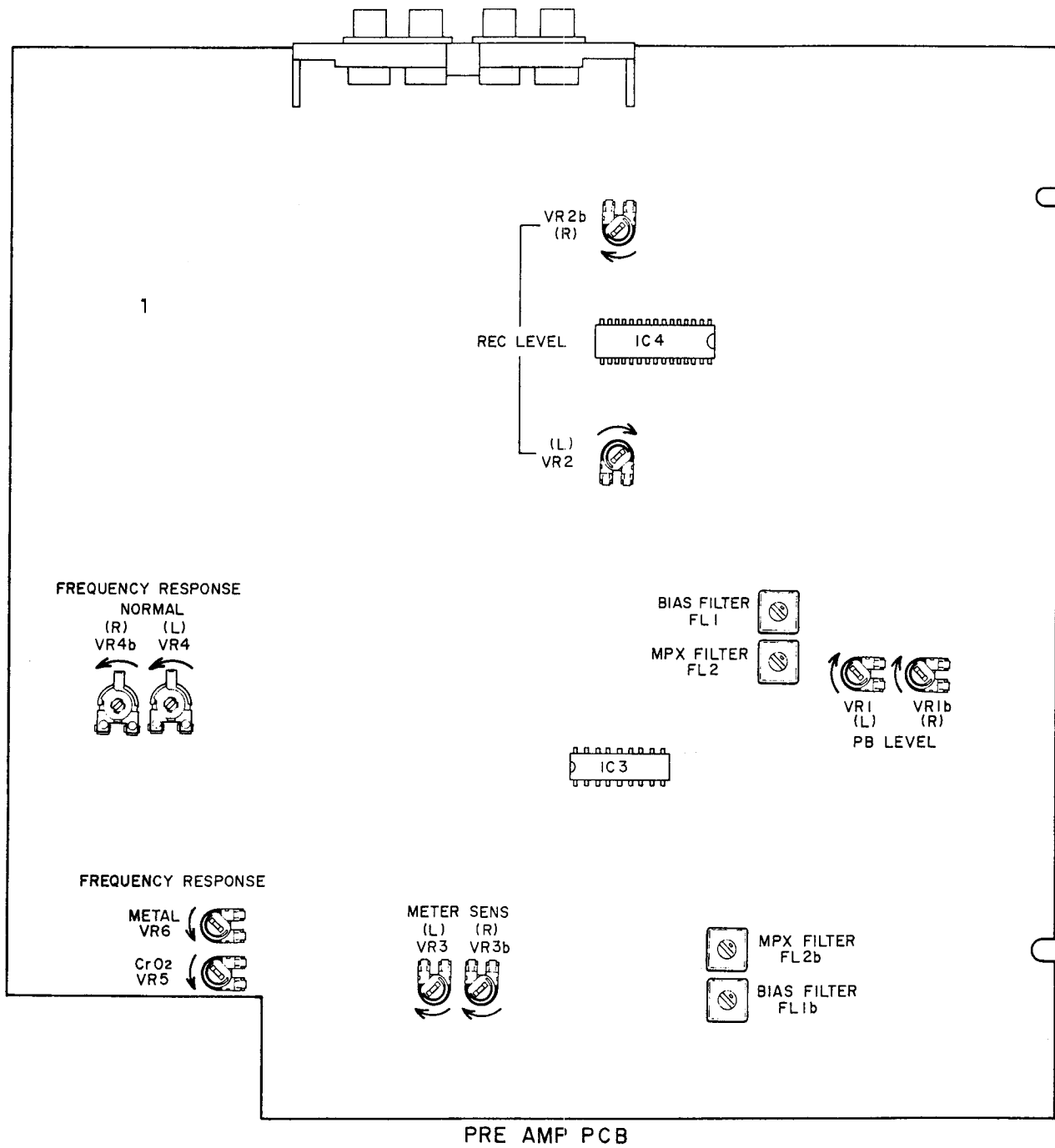

Fig. 8-1 Pre-Amplifier Adjustment Points

MODEL HX-2

Step	Adjustment Item	Test Tape Supply Signal	Mode	Adjustment Point	Result	Remarks
1	P.B Level	315Hz or 333Hz	P.B	VR1	$-5.5 \pm 0.2\text{dBm}$ or $-6.1 \pm 0.2\text{dBm}$	*See NOTE 1
2	Normal Position Frequency Response	Normal Blank Tape 1kHz, 10kHz -25.5dBm Recording	REC/P.B	VR4	1kHz and 10kHz Levels are within $\pm 0.5\text{dB}$	*See NOTE 2
3	CrO ₂ Position Frequency Response	CrO ₂ Blank Tape 1kHz, 10kHz -25.5dBm Recording	REC/P.B	VR5	1kHz and 10kHz Levels are within $\pm 0.5\text{dB}$	*See NOTE 2
4	Metal Position Frequency Response	Metal Blank Tape 1kHz, 10kHz -25.5dBm Recording	REC/P.B	VR6	1kHz and 10kHz Levels are within $\pm 0.5\text{dB}$	*See NOTE 2
5	REC Level	Normal Blank Tape 1kHz, -5.5dBm Recording	REC/P.B	VR2	$-5.5 \pm 0.3\text{dBm}$ (410mV)	*See NOTE 2
6	Bias Filter	Metal Blank Tape No Signal Input	REC/PAUSE	FL1	Minimum Output	
7	MPX Filter	19kHz from Oscillator	REC/PAUSE	FL2	Minimum Output	Dolby Switch ON
8	Meter Sensitivity	1kHz, -5.5dBm from Oscillator	REC/PAUSE	VR3	OVU Indication	

Note: 1. As the test tape has been changed, set to $-6.1 \pm 0.2\text{dBm}$ when using 333Hz test tape.
For details, refer to Service Guide (No. 0012) issued in Nov., 1982.

2. Use the following cassette measuring tapes.

Normal Tape : Maxell UD C-60
CrO₂ Tape : TDK SA C-60
Metal Tape : TDK MA C-60

3. Refer to Fig 8-1 for the adjustment points.

8-2. PRE -AMPLIFIER ADJUSTMENT POINT MODEL HX-3

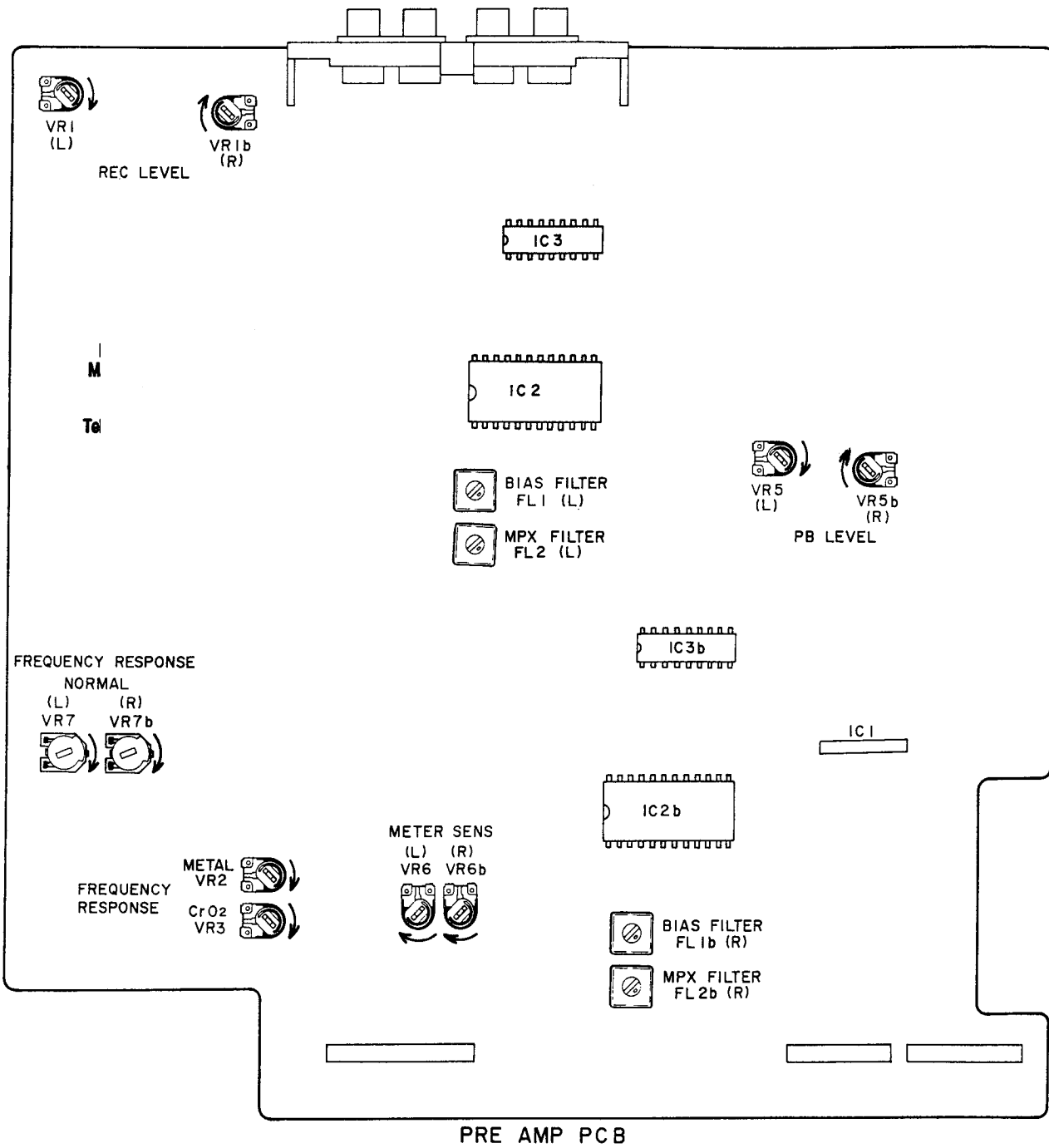

Fig. 8-2 Pre-Amplifier Adjustment Points

MODEL HX-3

Step	Adjustment Item	Test Tape Supply Signal	Mode	Adjustment Point	Result	Remarks
1	P.B Level	315Hz or 333Hz	P.B	VR5	$-5.5 \pm 0.2\text{dBm}$ or $-6.1 \pm 0.2\text{dBm}$	*See NOTE 1
2	Normal Position Frequency Response	Normal Blank Tape 1kHz, 10kHz -25.5dBm Recording	REC/P.B	VR7	1kHz and 10kHz Levels are within $\pm 0.5\text{dB}$	*See NOTE 2
3	CrO ₂ Position Frequency Response	CrO ₂ Blank Tape 1kHz, 10kHz -25.5dBm Recording	REC/P.B	VR3	1kHz and 10kHz Levels are within $\pm 0.5\text{dB}$	*See NOTE 2
4	Metal Position Frequency Response	Metal Blank Tape 1kHz, 10kHz -25.5dBm Recording	REC/P.B	VR2	1kHz and 10kHz Levels are within $\pm 0.5\text{dB}$	*See NOTE 2
5	REC Level	Normal Blank Tape 1kHz, -5.5dBm Recording	REC/P.B	VR1	$-5.5 \pm 0.3\text{dBm}$	*See NOTE 2
6	Bias Filter	Metal Blank Tape No Signal Input	REC/PAUSE	FL1	Minimum Output	
7	MPX Filter	19kHz from Oscillator	REC/PAUSE	FL2	Minimum Output	Dolby B Switch ON
8	Meter Sensitivity	1kHz, -5.5dBm from Oscillator	REC/PAUSE	VR6	OVU Indication	

Note: 1. As the test tape has been changed, set to $-6.1 \pm 0.2\text{dBm}$ when using 333Hz test tape.
For details, refer to Service Guide (No. 0012) issued in Nov., 1982.

2. Use the following cassette measuring tapes.

Normal Tape : Maxell UD C-60

CrO₂ Tape : TDK SA C-60

Metal Tape : TDK MA C-60

3. Refer to Fig 8-2 for the adjustment points.

IX. DC RESISTANCE OF VARIOUS COILS

MODEL HX-2/HX-3

DESCRIPTION	PARTS NAME	DC RESISTANCE
REC/P.B HEAD	HN424977	210ohms \pm 20%
ERASE HEAD	HJ213270	3.5ohms
PLUNGER SOLENOID	0730PLT	144ohms \pm 10%

X. CLASSIFICATION OF VARIOUS P.C BOARD

10-1 P.C BOARD TITLES AND IDENTIFICATION NUMBERS

P.C BOARD TITLE		P.C BOARD NUMBER	REMARK
PRE-AMP	P.C Board	T2043A501A	HX-2
PRE-AMP	P.C Board	T2044A501A	HX-3
JACK	P.C Board	T2043A501B	HX-2
JACK	P.C Board	T2044A501B	HX-3
SYSCON	P.C Board	T2043A502A	HX-2
SYSCON	P.C Board	T2044A502A	HX-3
JUNCTION	P.C Board	T2043A502B	HX-2
JUNCTION	P.C Board	T2044A502B	HX-3
POWER SUPPLY	P.C Board	T2045C5033	U
POWER SUPPLY	P.C Board	T2045C5034	C.A
POWER SUPPLY	P.C Board	T2045C5035	E.V.B.S. HX-3
POWER SUPPLY	P.C Board	T2045C5036	E.V.B.S. HX-2
DETECTOR	P.C Board	CMS01D5010	
CONNECTOR	P.C Board	CMS01D5020	

10-2. COMPOSITION OF VARIOUS P.C BOARD

1) HX-2, PRE-AMP P.C BOARD T2043A501A (2ED) and JACK P.C BOARD T2043A501B (2ED)

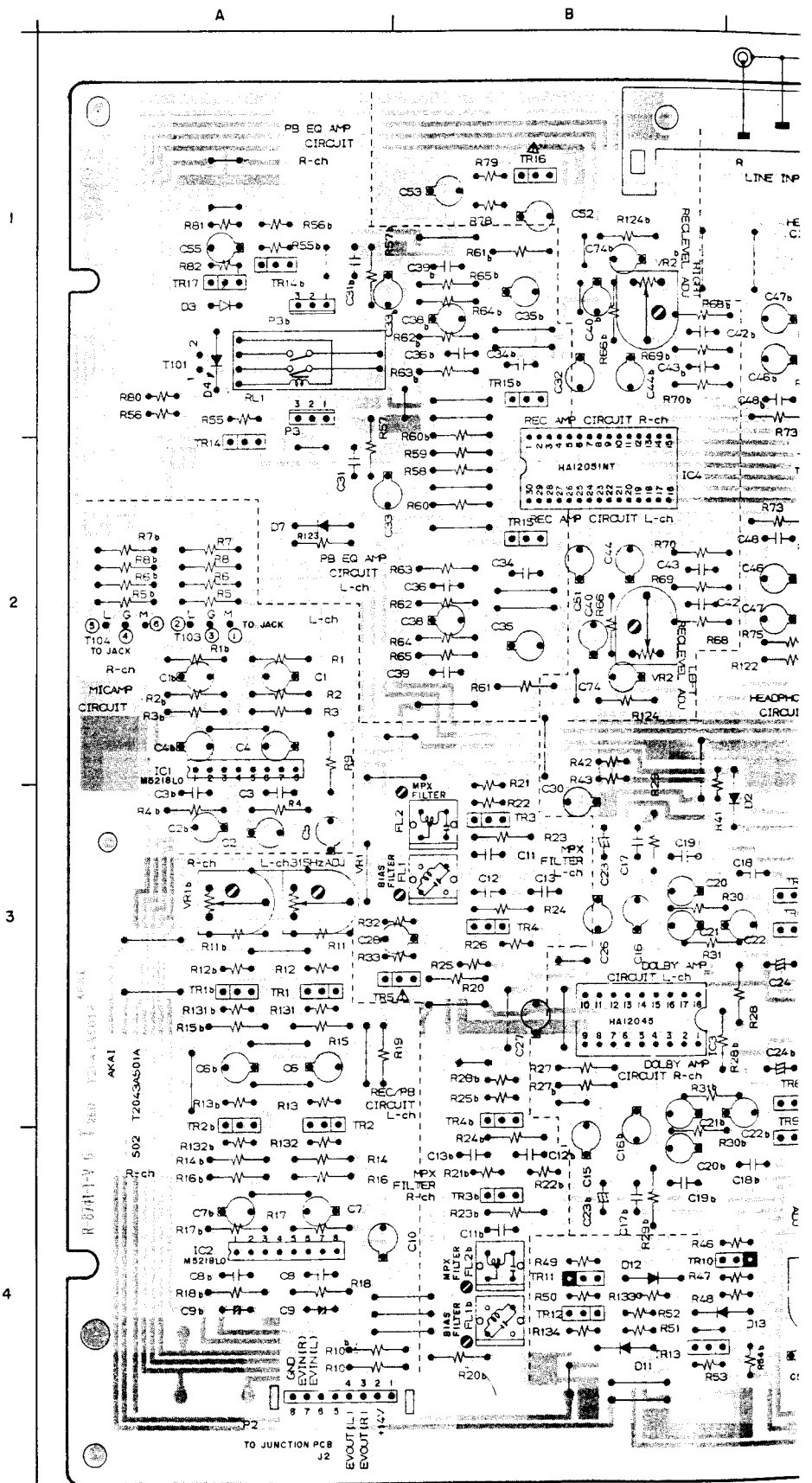

PRE-AMP PCB T2043A501A

ION OF VARIOUS P.C BOARD

C BOARD T2043A501A (2ED) and JACK P.C BOARD T2043A501B (2ED)

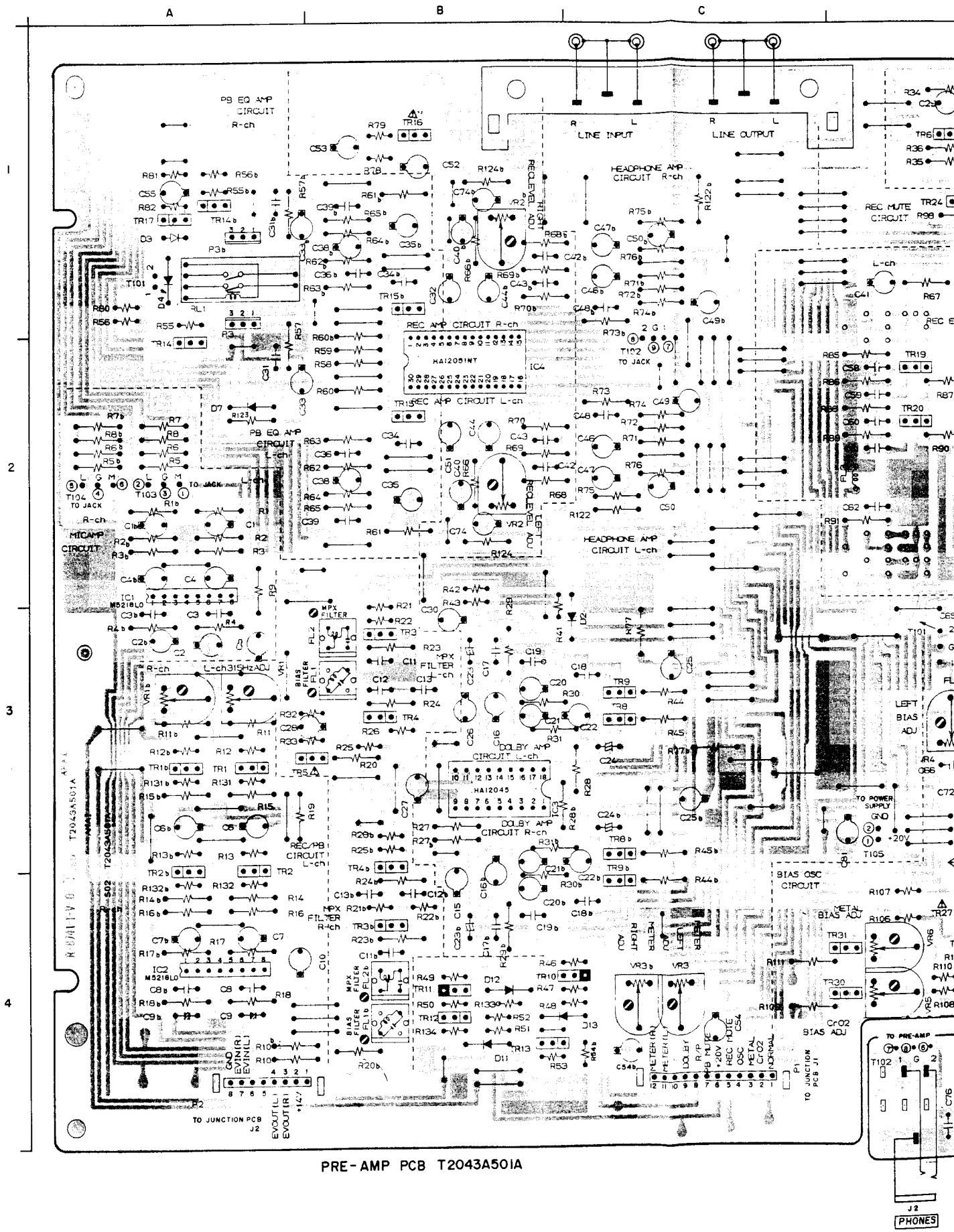

PRE-AMP PCB T2043A501A

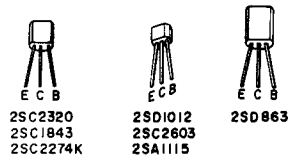
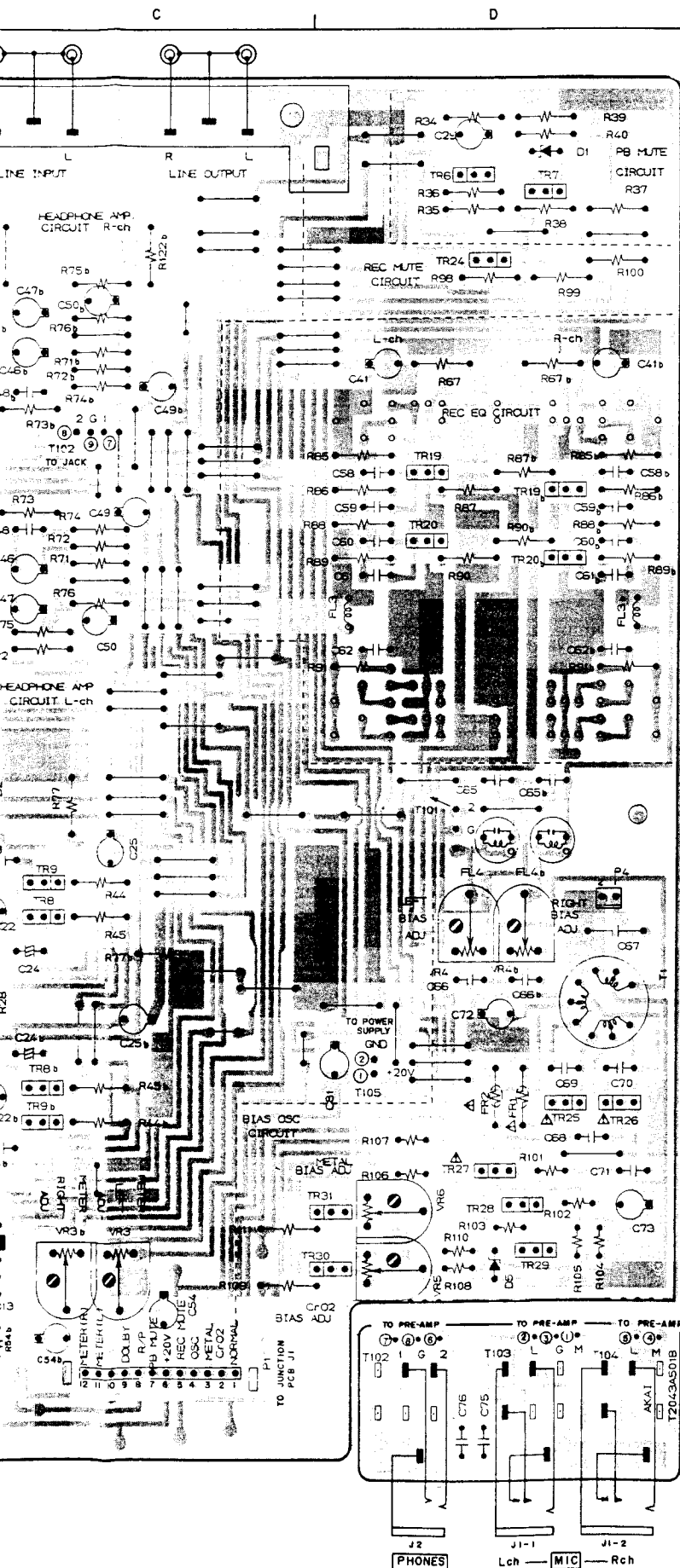

- TR1,2 ----- 25D1012-V(E,M)
- TR3,4,8,9,14,19,20 ----- 25C2320(E,F)
- TR5,16,27 ----- 25D863(E,F)
- TR6,7,12,13,17,24,28 to 31- 25C2803(E,F)
- TR10,11 ----- 25A1115(E,F)
- TR15 ----- 25C1843(E,F)
- TR25,26 ----- 25C2274K(E,F)

LOCATION OF COMPONENTS

TR	IC
TR1,1b --- A3	IC1 --- A2
TR2,2b --- A4	IC2 --- A4
TR3 --- B3	IC3 --- B3
TR3b --- B4	IC4 --- B2
TR4,4b --- B3	
TR5 --- B3	CONNECTOR
TR6 --- D1	P1 --- C4
TR7 --- D1	P2 --- A4
TR8,8b --- C3	P3,3b --- A1
TR9 --- C3	P4 --- D3
TR9b --- C4	T102 --- C2
TR10 to 13 --- B4	T103 --- A2
TR14 --- A2	T104 --- A2
TR14b --- A1	T105 --- D3
TR15 --- B2	
TR15b --- B1	
TR16 --- B1	
TR17 --- A1	
TR19,19b --- D2	
TR20,20b --- D2	
TR24 --- D1	
TR25,26 --- D3	
TR27 to 31 --- D4	

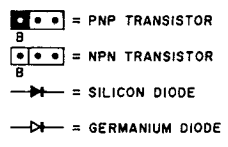

JACK PCB T2043A501B

2) HX-2, SYSCON P.C BOARD T2043A502A (2ED) and JUNCTION P.C BOARD T2043A502B (2ED)

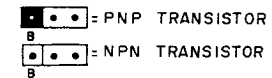
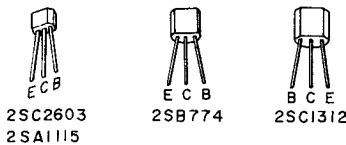
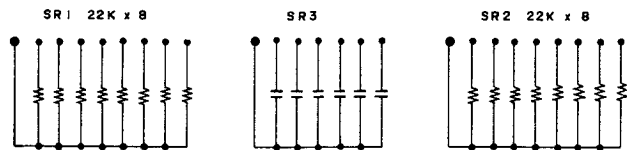
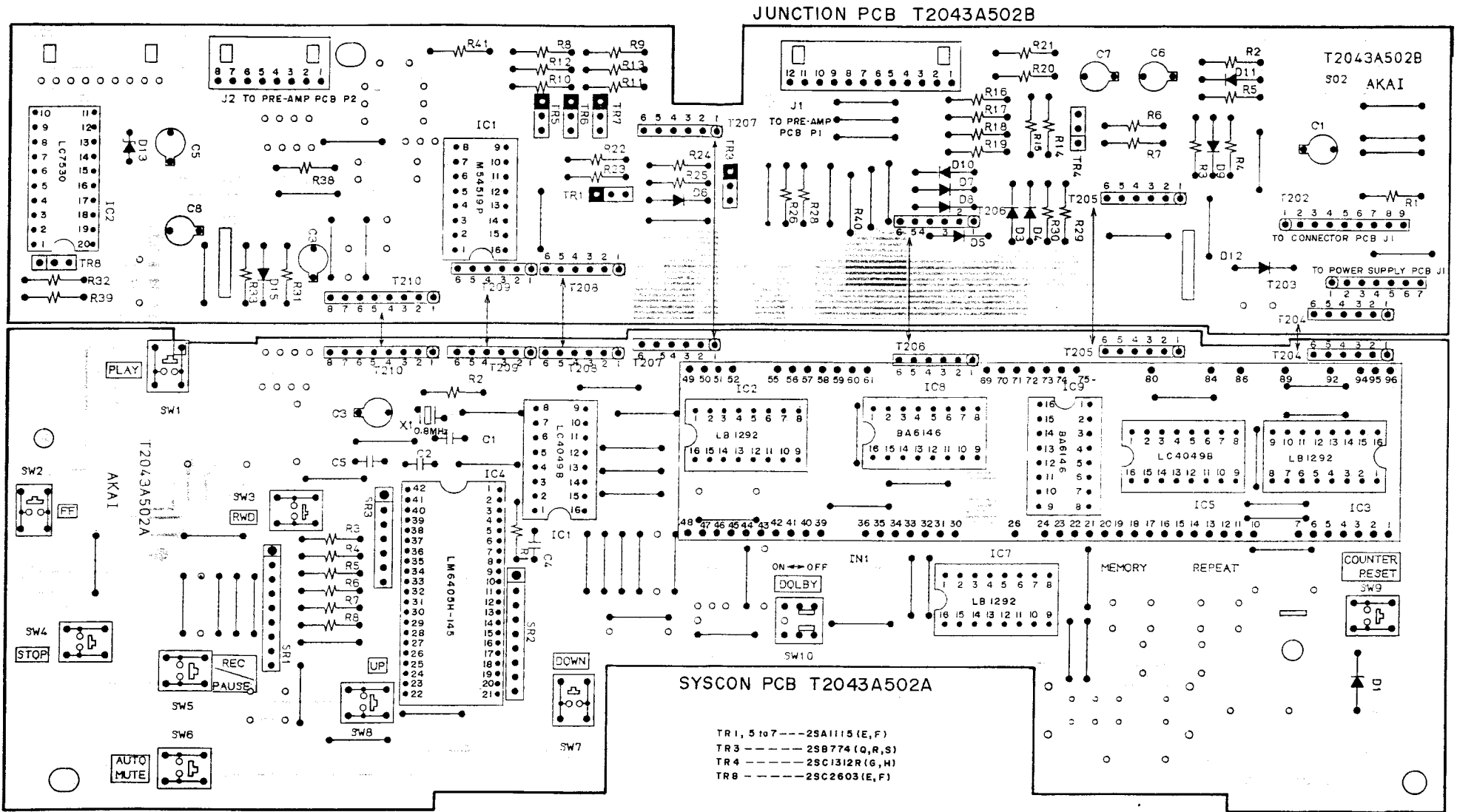

3) HX-3, PRE-AMP P.C BOARD T2044A501A and JACK P.C BOARD T2044A501B

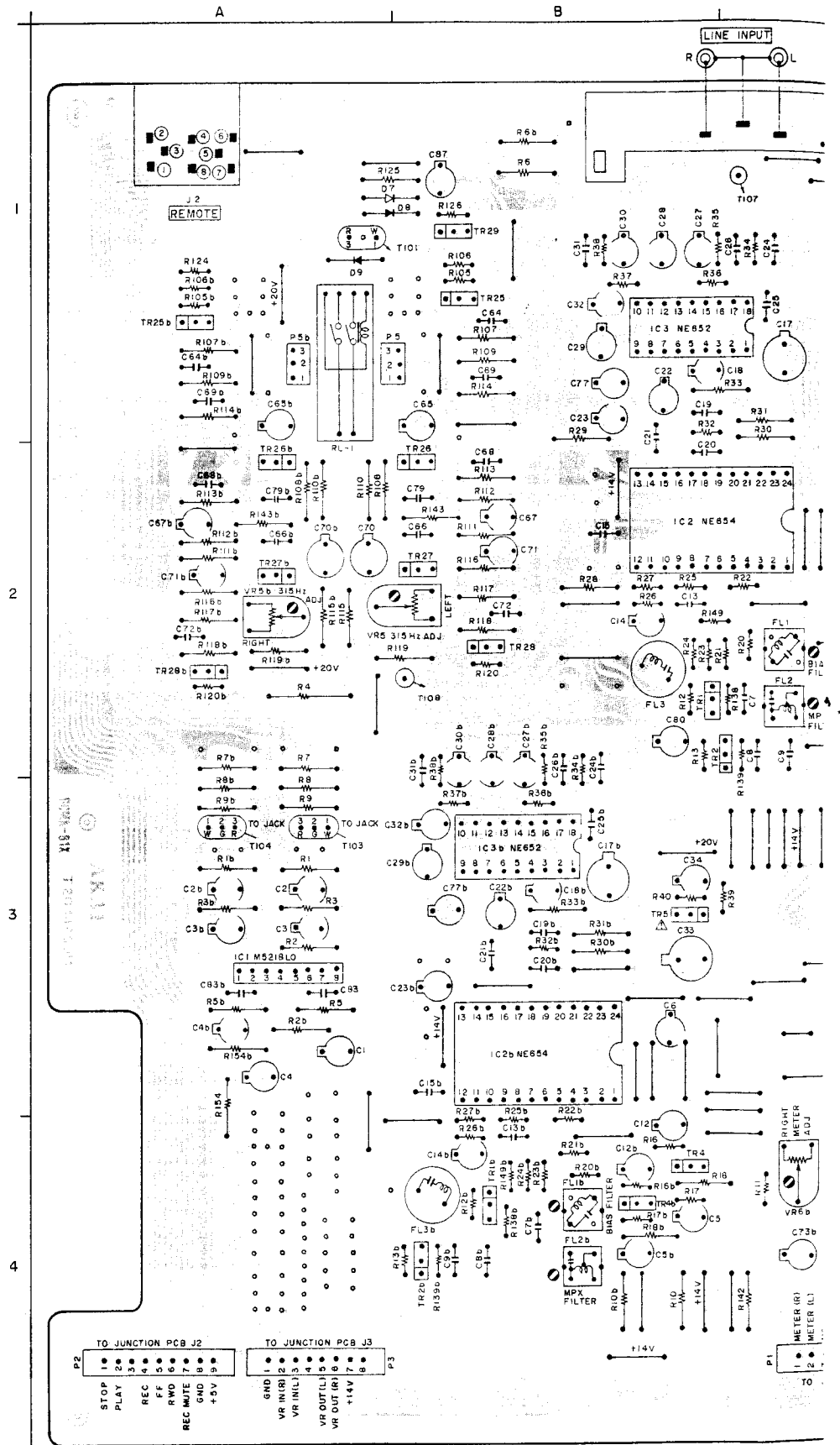

PRE-AMP PCB T2044A501A

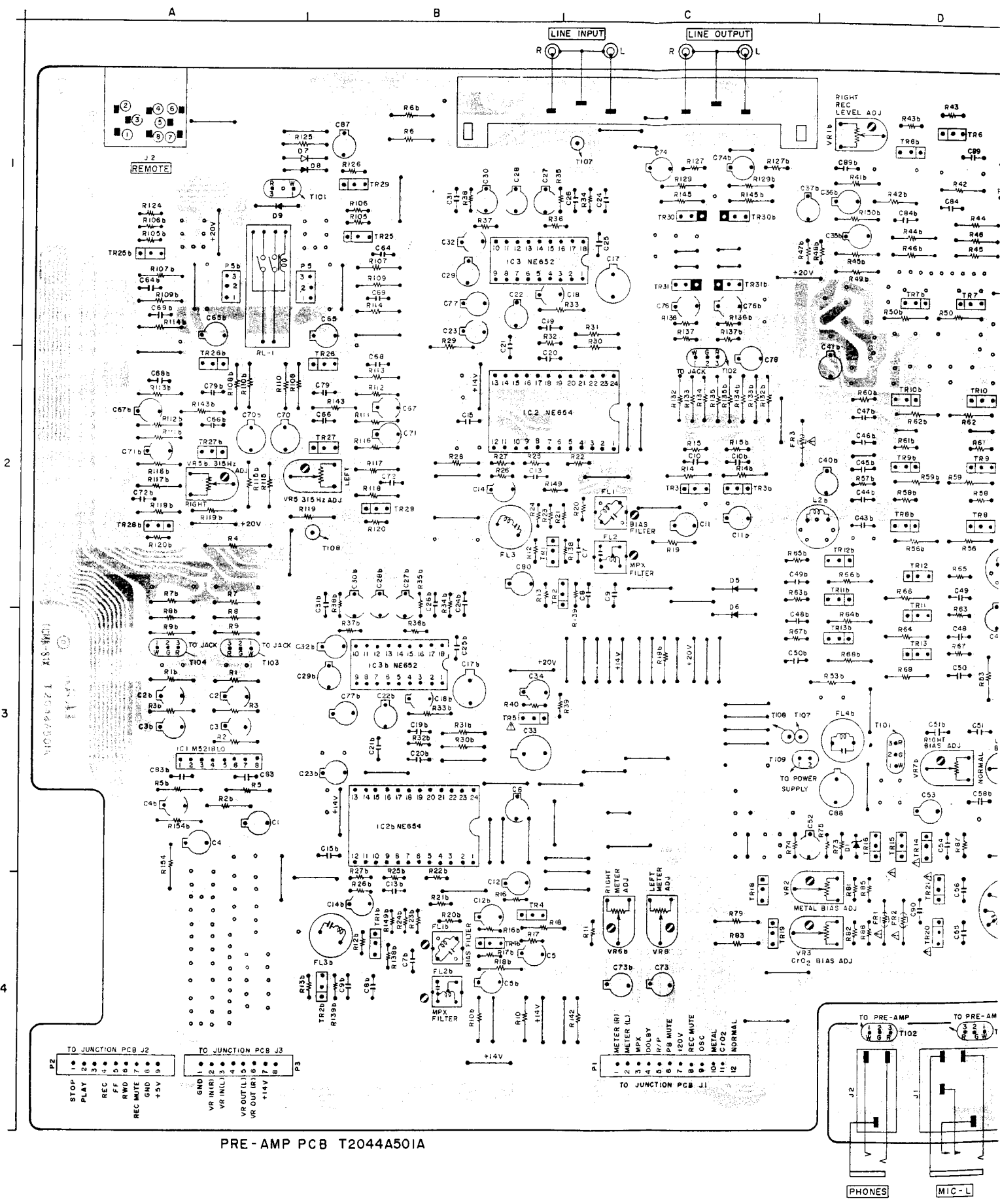

PRE-AMP PCB T2044A501A

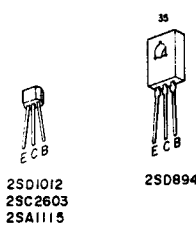
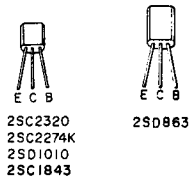
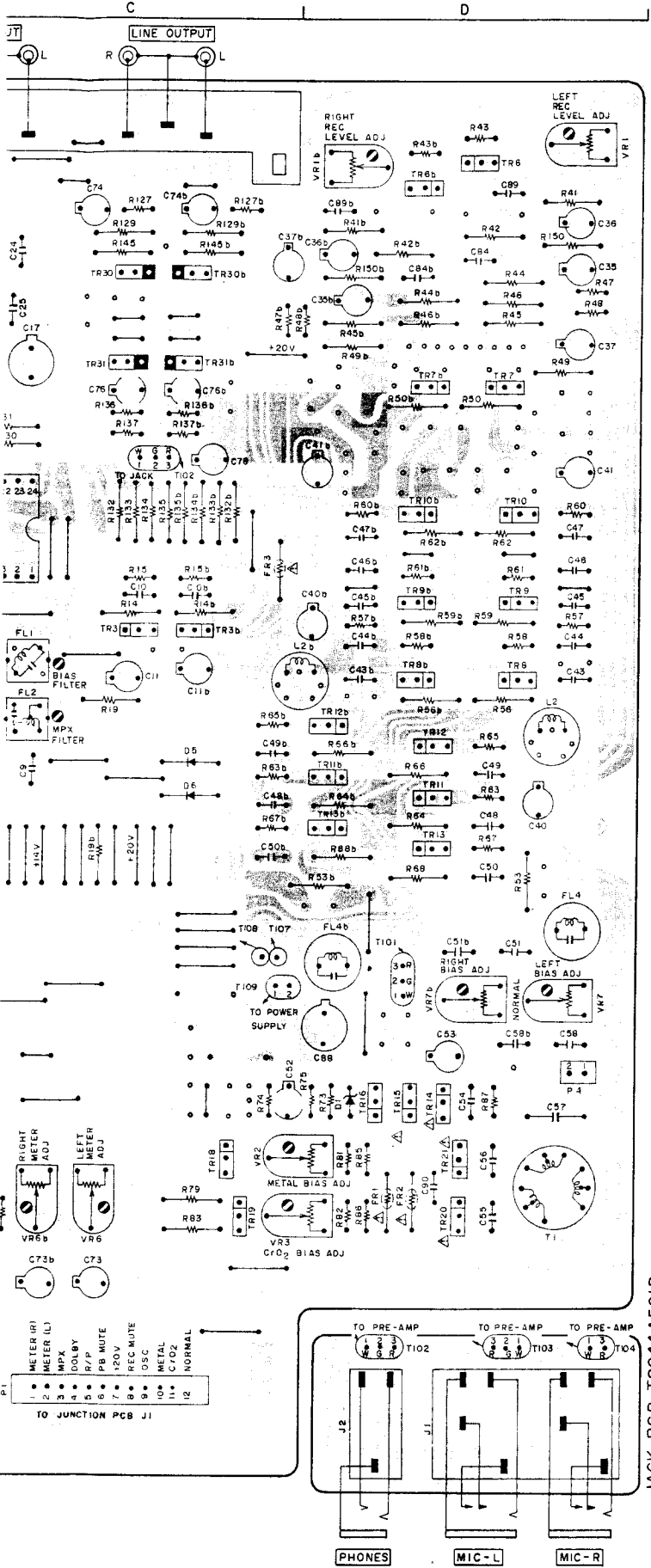

- TR 1, 2, 4, 7 to 13, 27, 28 --- 2SC2320 (E, F)
 TR 3 --- 2SD1010 (R, S)
 TR 5 --- 2SD894
 TR 6, 25 --- 2SD1012 (G, H)
 TR 14 --- 2SD863 (E, F)
 TR 15, 16, 18, 19, 29 --- 2SC2603 (F, G)
 TR 20, 21 --- 2SD2274K (E, F)
 TR 26 --- 2SC1843 (E, F)
 TR 30, 31 --- 2SA1115 (E, F)

LOCATION OF COMPONENTS

- | | |
|---------------|----------------|
| TR | IC |
| TR 1 | IC 1 --- A3 |
| TR 1b | IC 2 --- B2 |
| TR 2 | IC 2b --- B3 |
| TR 2b | IC 3 --- B1 |
| TR 3, 3b | IC 3b --- B3 |
| TR 4, 4b | |
| TR 5 | |
| TR 6, 6b | CONNECTOR |
| TR 7, 7b | P 1 --- C4 |
| TR 8 to 10 | P 2 --- A4 |
| TR 8b to 10 | P 3 --- A4 |
| TR 11, 11b | P 4 --- D3 |
| TR 12, 12b | P 5, 5b --- A1 |
| TR 13, 13b | T103 --- A3 |
| TR 14 to 16 | T104 --- A3 |
| TR 18, 19 | T109 --- C3 |
| TR 20, 21 | |
| TR 25 | |
| TR 25b | |
| TR 26 to 28 | |
| TR 26b to 28b | |
| TR 29 | |
| TR 30, 30b | |
| TR 31, 31b | |

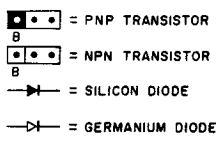

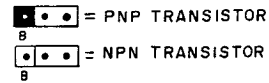
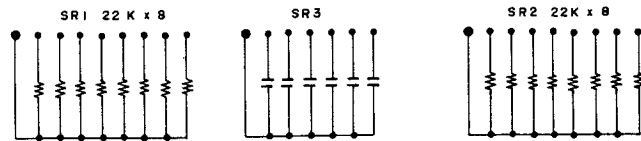
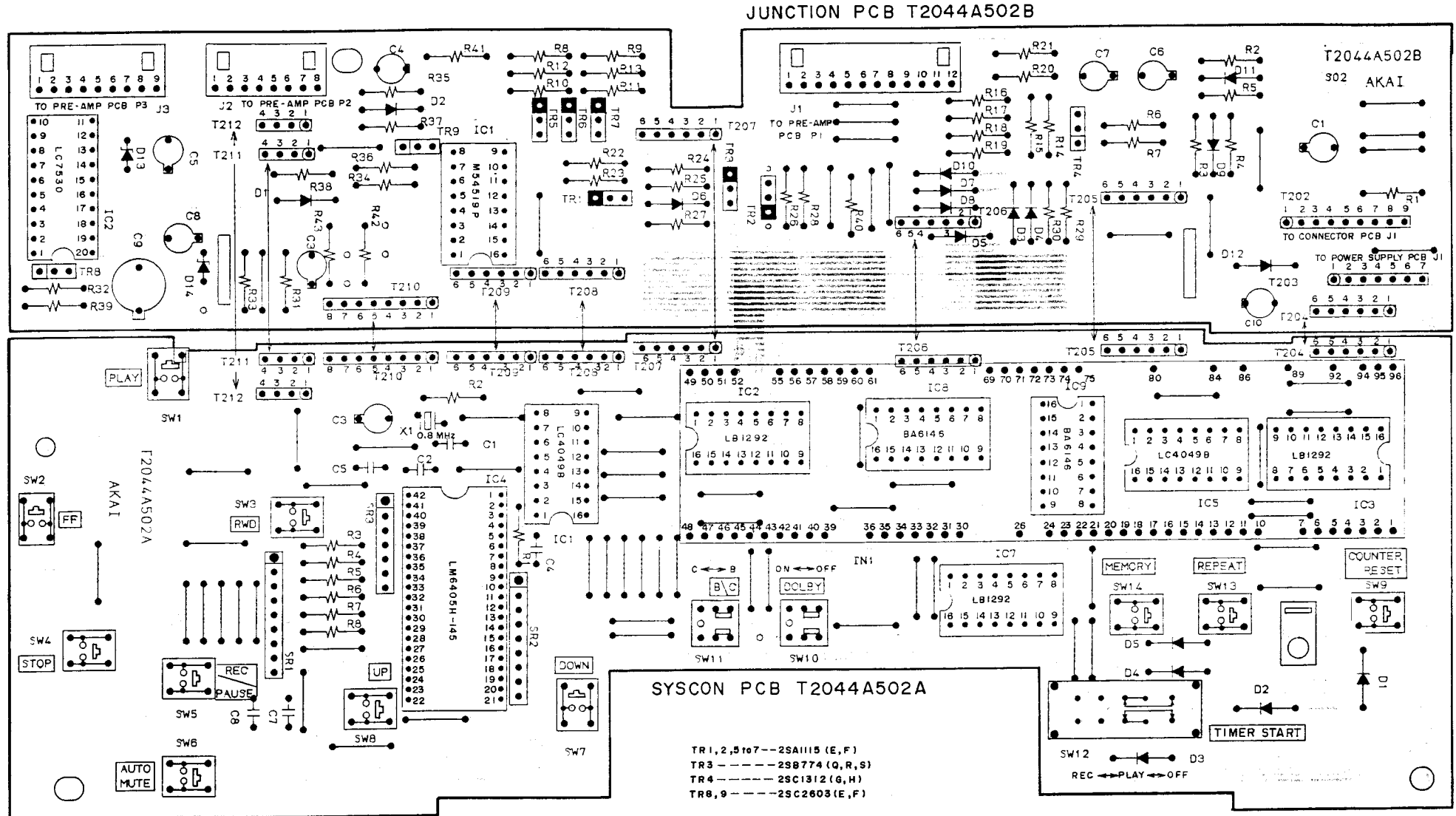

5) POWER SUPPLY P.C BOARD T2045C5033, T2045C5034, T2045C5035 and T2045C5036

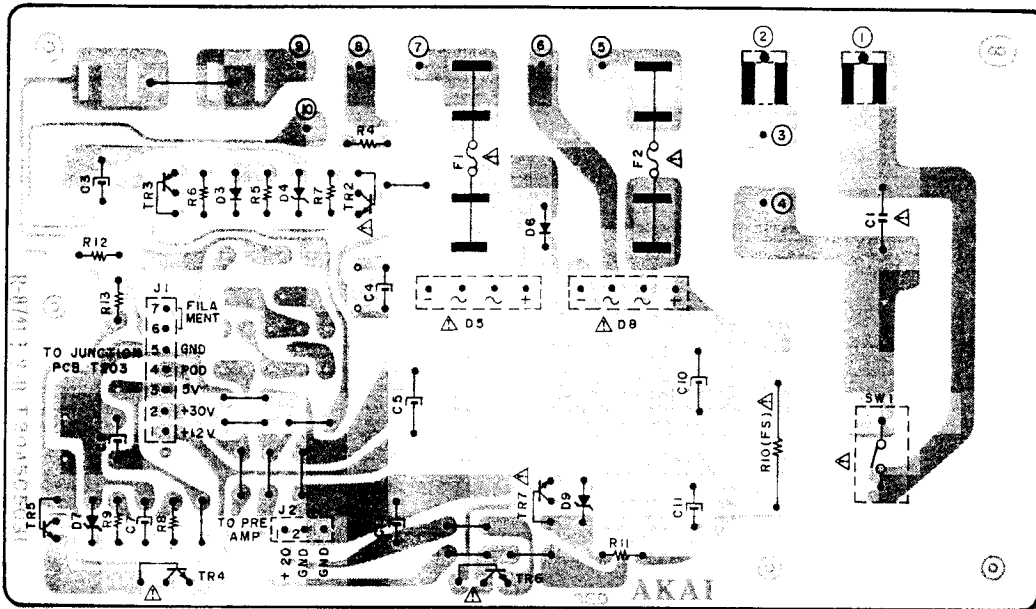

TR3 ---- 2SA1115 (E,F)
 TR2,5,7 -- 2SC2603(E,F)
 TR4,6 -- 2SD612K (E,F)

POWER SUPPLY PCB

- T2045C5033 U
- 5034 CA
- 5035 EVBS (HX-3)
- 5036 EVBS (HX-2)

WARNING: Δ INDICATES SAFETY CRITICAL COMPONENTS FOR CONTINUED SAFETY, REPLACE SAFETY CRITICAL COMPONENTS ONLY WITH MANUFACTURER'S RECOMMENDED PARTS

AVERTISSEMENT: Δ IL INDIQUE LES COMPOSANTS CRITIQUES DE SÉCURITÉ. POUR MAINTENIR LE DEGRÉ DE SÉCURITÉ DE L'APPAREIL, NE REMPLACER QUE DES PIÈCES RECOMMANDÉES PAR LE FABRICANT

6) DETECTOR P.C BOARD CMS01D5010, and CONNECTOR P.C BOARD CMS01D5020

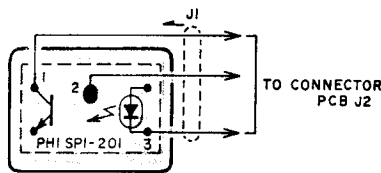

DETECTOR PCB
 CMS01D5010

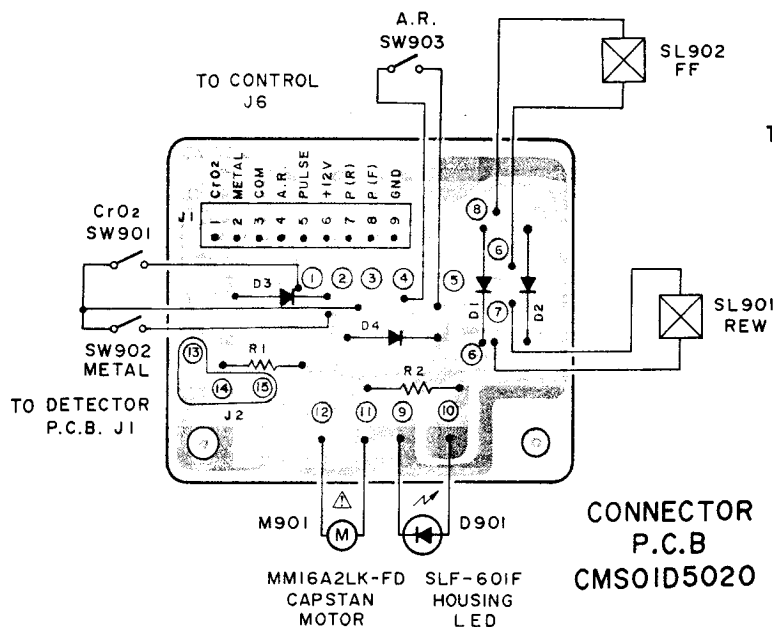
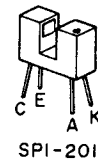

CONNECTOR
 P.C.B
 CMS01D5020

WARNING: Δ INDICATES SAFETY CRITICAL COMPONENTS FOR CONTINUED SAFETY, REPLACE SAFETY CRITICAL COMPONENTS ONLY WITH MANUFACTURER'S RECOMMENDED PARTS

AVERTISSEMENT: Δ IL INDIQUE LES COMPOSANTS CRITIQUES DE SÉCURITÉ. POUR MAINTENIR LE DEGRÉ DE SÉCURITÉ DE L'APPAREIL, NE REMPLACER QUE DES PIÈCES RECOMMANDÉES PAR LE FABRICANT

SECTION 2

PARTS LIST

TABLE OF CONTENTS

I. MODEL HX-2

RECOMMENDED SPARE PARTS (HX-R5) 35

1. MECHA CMS01 BLOCK (1/2) 37

2. MECHA CMS01 BLOCK (2/2) 37

3. PRE AMP P.C BOARD BLOCK 38

4. SYSCON P.C BOARD BLOCK 38

5. POWER SUPPLY P.C BOARD BLOCK 38

6. ASSEMBLY BLOCK 39

7. FINAL ASSEMBLY BLOCK 40

II. MODEL HX-3

RECOMMENDED SPARE PARTS 41

1. MECHA CMS01 BLOCK (1/2) 43

2. MECHA CMS01 BLOCK (2/2) 43

3. PRE AMP P.C BOARD BLOCK 44

4. SYSCON P.C BOARD BLOCK 44

5. POWER SUPPLY P.C BOARD BLOCK 44

6. ASSEMBLY BLOCK 45

7. FINAL ASSEMBLY BLOCK 46

INDEX 47

Please refer to COMMON LIST FOR SERVICE PARTS, for Resistor and Capacitor which are not listed in this list.

M

Tt

ATTENTION

1. When placing an order for parts, be sure to list the parts no., model no., and description. There are instances in which if any of this information is omitted, parts cannot be shipped or the wrong parts will be delivered.
2. Please be careful not to make a mistake in the parts no. If the parts no. is in error, a part different from the one ordered may be delivered.
3. Because parts number and parts unit supply in the Preliminary Parts List may be partially changed, please use this parts list for all future reference.

HOW TO USE THIS PARTS LIST

1. This Parts List shows the parts that are considered necessary for repairs. Other parts, such as resistors and capacitors, are shown in the "Common List for Service Parts". Select and order such parts from the "Common List for Service Parts".
2. The Recommended Spare Parts shows those parts in the Parts List which are considered particularly important for service.
3. Parts not shown in the Parts List and "Common List for Service Parts" will not be supplied in principle.
4. How to read list
 - a) Mechanism Block
 - b) P.C Board Block

2. HEAD BASE BLOCK

REF. NO.	PARTS NO.	DESCRIPTION
2-1x	BH-T2023A320A	HEAD BASE BLOCK GX-F66R
2-2	HP-H2206A010A	HEAD R/P PR4-8FU C
2-3	ZS-477876	PAN20x03STL CMT
2-4	ZS-536488	BID20x08STL CMT
2-5	ZG-402895	CS ANGLE ADJUST SPRING

SP (Service Parts) Classification

A small "x" indicates the inability to show that particular part in the Photo or Illustration.

This number corresponds with the individual parts index number in that figure

This number corresponds with the Figure Number

6. SYS. CON. P.C BOARD BLOCK

REF. NO.	PARTS NO.	DESCRIPTION
6-1	BA-T2034A070A	PC SYS CON BLK GX-F44R
6-IC1	EI-324536	IC HD14049BP
6-IC2	EI-336801	IC MB8841-564M
6-IC3	EI-331661	IC SN7405N
6-IC4	EI-336725	IC M54527P
6-TR1to4	ET-200985	TR 2SC2603 F,G
6-TR5to28	ET-554657	TR 2SA733A P,Q
6-D1	ED-318292	D SILICON H 1S2473T-77 T26
6-D2to4	ED-308952	D GERMA V 1K34A-LR F07
6-D5to10	ED-318292	D SILICON H 1S2473T-77 T26
6-X1	EI-318384	OSC X'TAL NC-18C 3.579545MHZ

SP (Service Parts) Classification

This reference numbers corresponds with symbol numbers of Schematic Diagrams.

5. Both the kind of part and installation position can be determined by the Parts Number. To determine where a parts number is listed, utilize Parts Index at end of Parts List. It is necessary first of all to find the Parts Number. This can be accomplished by using the Reference Number listed at right of parts number in the Parts Index.

WARNING

△ INDICATES SAFETY CRITICAL COMPONENTS. FOR CONTINUED SAFETY, REPLACE SAFETY CRITICAL COMPONENTS ONLY WITH MANUFACTURER'S RECOMMENDED PARTS.

AVERTISSEMENT

△ IL INDIQUE LES COMPOSANTS CRITIQUES DE SÉCURITÉ. POUR MAINTENIR LE DEGRÉ DE SÉCURITÉ DE L'APPAREIL, NE REMPLACER QUE DES PIÈCES RECOMMANDÉES PAR LE FABRICANT

I. MODEL HX-2

RECOMMENDED SPARE PARTS

Because, if the parts listed below are on hand, almost any repair can be accomplished, we suggest that you stock these Recommended Spare Parts Items.

REF. NO.	PARTS NO.	DESCRIPTION
1	BM-B314815	MOTOR (PULLEY) PART HX-M5
2	BT-347667	Δ TRANS POWER T2043-AC (C, A)
3	BT-347669	Δ TRANS POWER T2043-BB (B, S)
4	BT-347668	Δ TRANS POWER T2043-EV (E, V)
5	BT-347665	Δ TRANS POWER T2043-U (U)
6	EC-344480	C COMP 05-0009
7	ED-330319	Δ D SILICON DBA10B 100/1.0A
8	ED-308952	D GERMA V 1K34A-LR F07
9	ED-337010	D LED SLF201C GRN
10	ED-301911	D SILICON H SD448
11	ED-337575	D SILICON H GMA-01-4-BT T26
12	ED-306109	D SILICON W03B 100/1.0A
13	ED-337868	D ZENER V HZ20-3S1
14	ED-346286	D ZENER V HZ3C-3S1
15	ED-345027	D ZENER V HZ5C-3S1
16	ED-336998	D ZENER V HZ6B-2S1
17	ED-345822	D ZENER V HZ6C-3S1
18	ED-335821	D ZENER V HZ7A-1S1
19	EF-593706	Δ FUSE SEMKO T 250V 0.50A (F2)
		(E, V, B, S)
20	EF-601942	Δ FUSE SEMKO T 250V 0.63A (F1)
		(E, V, B, S)
21	EF-306124	Δ FUSE TSC A 250V 0.63A (F1, 2) (U)
22	EF-305703	Δ FUSE TSC 125V 0.63A (F1, 2) (C, A)
23	EI-337845	IC BA6146 M
24	EI-347634	IC HA12045
25	EI-347635	IC HA12051NT
26	EI-345765	IC LB1292
27	EI-337009	IC LC4049B
28	EI-345759	IC LC7530
29	EI-344277	IC LM6405H-145
30	EI-337228	IC MS218L0
31	EI-300042	IC MS4519P
32	EI-337017	OSC CE CSB800A 0.800000MHz
33	EM-347643	IND FL FIP32AW11Y
34	EO-337523	COIL FIX 1 L-8 22μH J
35	EO-348235	COIL FIX 1 L-8 6.8MH J
36	EO-337774	COIL OSC 1 0365-056 100.0kHz
37	EP-337067	RELAY LEAD LAB2NS 2ND 18V
38	EP-344251	SOLENOID 0730PLT 12V
39	ER-307565	Δ R FUSE ERD2FC S10 1/4W 6R8J
40	ER-337695	FILTER DB 201AK-005 100kHz
41	ER-337696	FILTER DB 201AK-006 19kHz
42	ER-347164	R COMP RKC 1/8 B8 223J
43	ES-305733	Δ SW SELECTOR HXW0131-260 01-4 (U ONLY)
44	ES-344253	SW LEAF MSW-1418J 01-1 NO
45	ES-344257	SW LEAF MSW-1418L 01-1 NO
46	ES-337843	SW PUSH ESB-64501 02-2
47	ES-336780	SW TACK KHH10902
48	ET-310148	Δ 2SD612K E, F
49	ET-307349	Δ 2SD794 P, Q
50	ET-311977	PHOTO SENSOR SPI-201
51	ET-200558	TR 2SA1115 E, F
53	ET-517263	TR 2SC1312R G, H
54	ET-309353	TR 2SC2274K E, F
55	ET-328578	TR 2SC2320 E, F
56	ET-200505	TR 2SC2603 E, F
57	ET-328868	TR 2SD1012-V G, H
58	ET-318239	TR 2SD863 E, F
59	EV-315416	R S-FIX H D8 3P 103
60	EV-332413	R S-FIX H D8 3P 302
61	EV-315413	R S-FIX H D8 3P 503
62	EV-336785	R S-FIX H TM8KV2-1S 3P 0.50W 104
63	HE-337047	HEAD E HJ213270 C
64	HP-344252	HEAD R/P HN424977
65	MB-344231	BELT 1.0xD33.3CR HS60
66	MB-344905	BELT 1.2xD38.2CR HS60
67	MB-344230	BELT 3.0x0.5TxD61CRHS60
68	MI-B344207	ARM IDLER FR PART
69	MI-B344215	ARM IDLER TU PART

MECHA CMS01 BLOCK (1/2)

1. MECHA CMS01 BLOCK (1/2)

REF NO.	PARTS NO.	DESCRIPTION
HEAD BLOCK		
1-1	BH-T2051A030B	HEAD BLK HX-2
1-2	ZG-343104	SP PUSH EH
1-3	ZG-344900	SP PUSH PB (B)
1-4	ZS-417328	BID23x10STL CMT
1-5	ZS-565211	BID20x10STL NI3
1-6	HP-344252	HEAD R P HN424977 (H901)
1-7	HE-337047	HEAD E HJ213270 C (H902)
PINCH ROLLER (A) BLOCK		
1-8	BL-T2051A040A	PINCH ROLLER (A) BLK HX-M5
1-9	MP-336153	PINCH ROLLER (A)
HOLDER DETECTION BLOCK		
1-10	ES-344253	SW LEAF MSW-1418L 01-1 NO (SW901, 902)
1-11	ES-344257	SW LEAF MSW-1418L 01-1 NO (SW903)
1-12	ZG-312995	SP T1-4.0/0.4-11.2 T1-108
MECHA CMS01 BLOCK		
1-13x	BB-T2051A020B	MECHA CMS01 BLK HX-2
1-14	MT-344187	REEL TABLE
1-15	ZG-344188	SP PUSH REEL TABLE
1-16	MT-344190	REEL RETAINER
1-17	MT-305793	REEL CAP
1-18	ZW-305546	PW21x040x025PSL
1-19	ML-344191	LEVER BRAKE (L)
1-20	ML-344192	LEVER BRAKE (R)
1-21	ZG-344194	SP TORSION BRAKE
1-22	MZ-344906	GEAR FF (B)
1-23	ZW-343120	PW17x040x025PSL
1-24	ML-334196	LEVER (A)
1-25	ZG-344200	SP PULL HEAD CHASSIS
1-26	ML-344197	LEVER (B)
1-27	TC-344198	LEVER EJECT STOPPER
1-28	ZG-344199	SP TORSION EJECT LOCK
1-29	MV-357028	BALL200STL
1-30	BD-B344206X1	LID DECORATION PART
1-31	ED-337010	D LED SLF201CGRN
1-32	TC-344236	LEVER EJECT
2-33	ZG-312925	SP T1-3.2/0.2-14.0 T1-042
1-34	MZ-344297	DUMPER ASSY
1-35	SE-344239	LID HOLDER
1-36	ZG-336615	SP PLATE CASSETTE HOLDER (B)
1-37	ZG-344240	SP TORSION LID HOLDER
1-38	MZ-B344179	MECHA CHASSIS PART

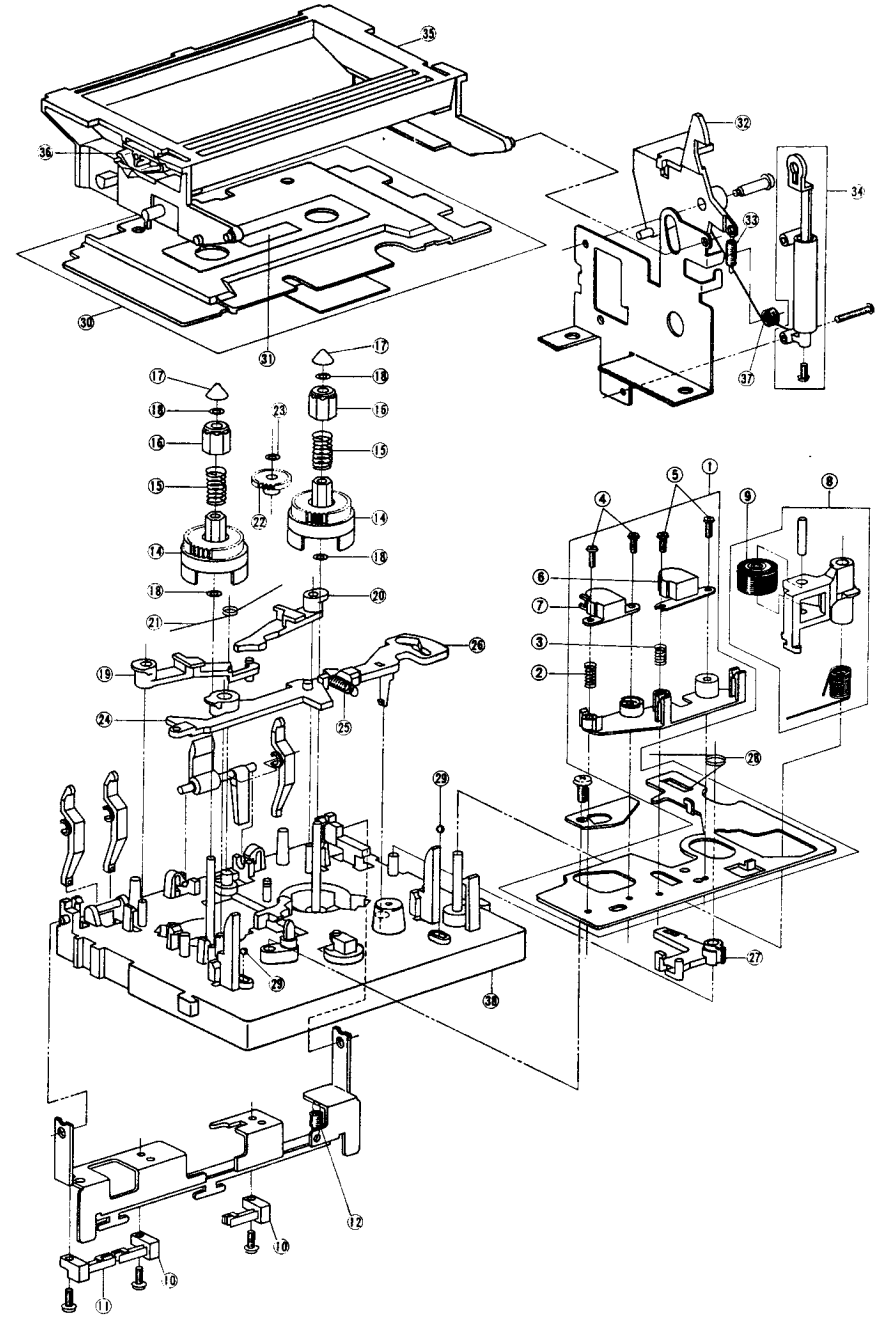

MECHA CMS01 BLOCK (2/2)

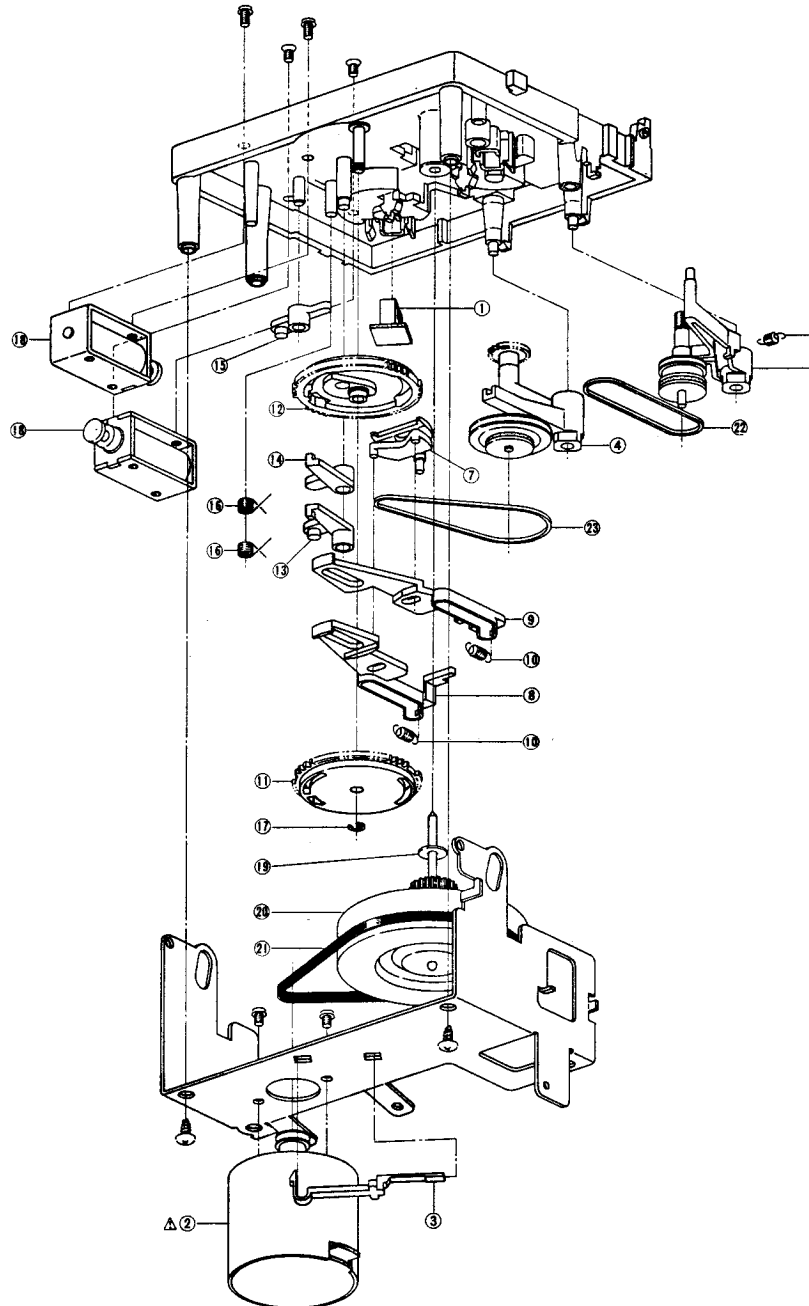

2. MECHA CMS01 BLOCK (2/2)

REF. NO.	PARTS NO.	DESCRIPTION
DETECTOR P.C BOARD		
2-1	ET-311977	PHOTO SENSOR SPI-201 (PH1)
HOLDER MOTOR BLOCK		
2-2	BM-B314815	△ MOTOR (PULLEY) PART
2-3	TC-344901	HOLDER THRUST HX-M5 (M901)
MECHA CMS01 BLOCK		
2-4	MI-B344207	ARM IDLER FR PART
2-5	MI-B344215	ARM IDLER TU PART
2-6	ZG-343152	SP PULL TU IDLER
2-7	TC-344219	CAM SHIFTER
2-8	SK-344220	SLIDE (F)
2-9	TC-344221	SLIDE (R)
2-10	ZS-343153	SP PULL SLIDE
2-11	TP-344222	CAM (F)
2-12	TP-344223	CAM (R)
2-13	TC-344224	ARM LOCK (F)
2-14	TC-344225	ARM LOCK (R)
2-15	TC-344226	ARM JOINT
2-16	ZW-344227	SP TORSION PLUNGER
2-17	ZW-340648	RING CS190STL PKR
2-18	EP-344251	SOLENOID 0730PLT 12V (SL901.902)
2-19	ZW-345389	PW26x080x020NYL
2-20	MI-B344228	FLYWHEEL PART
2-21	MB-344230	BELT 3.0x0.5TxD61CRHS60
2-22	MB-344231	BELT 1.0xD33.3CR HS60
2-23	MB-344905	BELT 1.2xD38.2 CR HS60
CONNECTOR P.C BOARD		
2-D1.2	ED-306109	D SILICON W03B 100/1.0A
2-D3.4	ED-301911	D SILICON H DS448

Tg N

3. PRE AMP P.C BOARD BLOCK

REF. NO.	PARTS NO.	DESCRIPTION
3-1	BA-T2043A020A	PC PRE AMP BLK HX-2
PRE AMP P.C BOARD		
3-IC1A, 2A	EI-337228	IC M5218L0
3-IC3A	EI-347634	IC HA12045
3-IC4A	EI-347635	IC HA12051NT
3-TR1A, 2A	ET-328868	TR 2SD1012-V G. H
3-TR3A, 4A	ET-328578	TR 2SC2320 E. F
3-TR5	ET-318239	Δ TR 2SD863 E. F
3-TR6A, 7A	ET-200505	TR 2SC2603 E. F
3-TR8A, 9A	ET-328578	TR 2SC2320 E. F
3-TR10A, 11A	ET-200558	TR 2SA1115 E. F
3-TR12A, 13A	ET-200505	TR 2SC1603 E. F
3-TR14A	ET-328578	TR 2SC2230 E. F
3-TR15A	ET-337258	TR 2SC1843 E. F
3-TR16A	ET-318239	TR 2SD863 E. F
3-TR17A	ET-200505	TR 2SC2603 E. F
3-TR19A	ET-328578	TR 2SC2320 E. F
3-TR24A	ET-300505	TR 2SC2320 E. F
3-TR25A, 26A	ET-309353	Δ TR 2SC2274K E. F
3-TR327A	ET-318239	TR 2SD863 E. F
3-TR28A to 31A	ET-200505	TR 2SC2603 E. F
3-D1A	ED-345027	D ZENER V HZ5C-3S1
3-D2A	ED-301911	D SILICON H DS448
3-D3A	ED-308952	D GERMA V 1K34A-LR F07
3-D4A	ED-301991	D SILICON H DS448
3-D5A	ED-346286	D ZENER V HZ3C-3S1
3-D7A	ED-301911	D SILICON H DS448
3-D11A to 13A	ED-301911	D SILICON H DS448
3-VR1A	EV-315413	R S-FIX H D8 3P 503
3-VR2A	EV-315416	R S-FIX H D8 3P 103
3-VR3A	EV-315413	R S-FIX H D8 3P 503
3-VR4A	EV-336785	R S-FIX H TM8KV2-1S 3P 0.50W 104
3-VR5A	EV-315416	R S-FIX H D8 3P 103
3-VR6A	EV-322413	R S-FIX H D8 3P 302
3-RL1A	EP-337067	RELAY LEAD LAB2NS 2NO 18V
3-T1A	EO-337774	COIL OSC 1 0365-056 100.0kHz
3-FL1A	ER-337695	FILTER DB 201AK-005 100kHz
3-FL2A	ER-337696	FILTER DB 201AK-006 19kHz
3-FL3A	EO-348235	COIL FIX 1 L-8 6.80MH J
3-FL4A	EO-337523	COIL FIX 1 L-8 22μH J
3-J1A	EJ-347664	PIN J YKC21-5053 P 4P
3-FR1A, 2A	ER-307565	Δ R FUSE ERD2FC S10 1/4 6R8J
3-C9A	EC-333996	C EC V F05 NP SM 220M 16DC
3-C31A	EC-310440	C STY V F05 CQF09 471J 50DC
3-C34A	EC-306017	C STY V F05 CQ09S 221J 50DC
3-C48A	EC-306017	C STY V F05 CQ09S 221J 50DC
3-C65A	EC-306022	C STY V F05 CQ09S 821J 50DC
3-C67A	EC-345817	C PP V F10 APH 272J 630DC
3-C68A	EC-337966	C PP V APS 103J 100DC
3-C91A	EC-319949	C STY V F05 CQF09 121J 50DC
JACK P.C BOARD		
3-J1B	EJ-347631	PHONE J HLI0527-330 2x2P
3-J2B	EJ-343380	PHONE J 3P HLI0541-040 6.3

4. SYSCON P.C BOARD BLOCK

REF. NO.	PARTS NO.	DESCRIPTION
4-1	BA-T2043A030A	PC SYSCON BLK HX-2
SYSCON P.C BOARD		
4-IC1A	EI-337009	IC LC4049B
4-IC2A, 3A	EI-345765	IC LBI292
4-IC4A	EI-344277	IC LM6405H-145
4-IC5C	EI-337009	IC LC4049B
4-IC7A	EI-345765	IC LBI292
4-IC8A, 19A	EI-337845	IC BA6146 M
4-D1A	ED-301911	D SILICON H DS448
4-IN1A	EM-347643	IND FL FIP32AW11Y
4-SW1A to 9A	ES-336780	SW TACT KHH10902
4-SW10A	ES-337843	SW PUSH ESB-64501 02-2
4-X1A	EI-337017	OSC CE CSB800A 0.800000MHz
4-SR1A, 2A	ER-347164	R COMP RKC 1.8 B8 223J
4-SR3A	EC-344480	C COMP 05-0009
JUNCTION P.C BOARD		
4-IC1B	EI-300042	IC M54519P
4-IC2B	EI-345759	IC LC7530
4-TR1B	EI-200558	TR 2SA1115 E. F
4-TR3B	ET-332422	TR 2SB774 Q, R, S
4-TR4B	ET-517263	TR 2SC1312R, G, H
4-TR5B to 7B	ET-200558	TR 2SA1115 E. F
4-TR8B	ET-200505	TR 2SC2603 E. F
4-D3B to 12B	ED-301911	D SILICON H DS448
4-D13B	ED-345821	D ZENER V HZ7A-1S1
4-D15B	ED-301911	D SILICON H DS448

5. POWER SUPPLY P.C BOARD BLOCK

REF. NO.	PARTS NO.	DESCRIPTION
5-TR2	ET-200505	Δ TR 2SC2603 E. F
5-TR3	ET-200558	TR 2SA1115 E. F
5-TR4	ET-310148	Δ TR 2SD612K E. F
5-TR6	ET-307349	Δ TR 2SD794 P, Q
5-TR7	ET-200505	Δ TR 2SC2603 E. F
5-D3	ED-337575	D SILICON H GMA-01-4-BT T26
5-D4	ED-336998	D ZENER V HZ6B-2S1
5-D5	ED-330319	Δ D SILICON DBA10B 100/1.0A
5-D6	ED-306109	D SILICON W03B 100/1.0A
5-D7	ED-345822	D ZENER V HZ6C-3S1
5-D8	ED-330319	Δ D SILICON DBA10B 100/1.0A
5-D9	ED-337868	D ZENER V HZ20-3S1
5-R10	ER-337778	Δ R OMF H S15 FS 1W 122J (U)
5-C1U	EC-346790	Δ C MY V ECQEW 333M 250AC (U)
5-C1C	EC-338411	Δ C CE V FZ 103P 400AC (EXCEPT U)
5-C10	EC-323846	C EC V CUT H 102M 35.0DC

ASSEMBLY BLOCK

T6

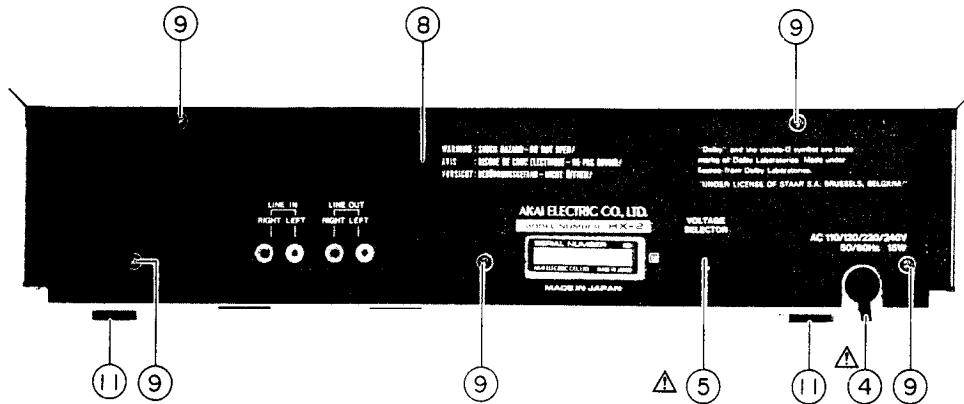
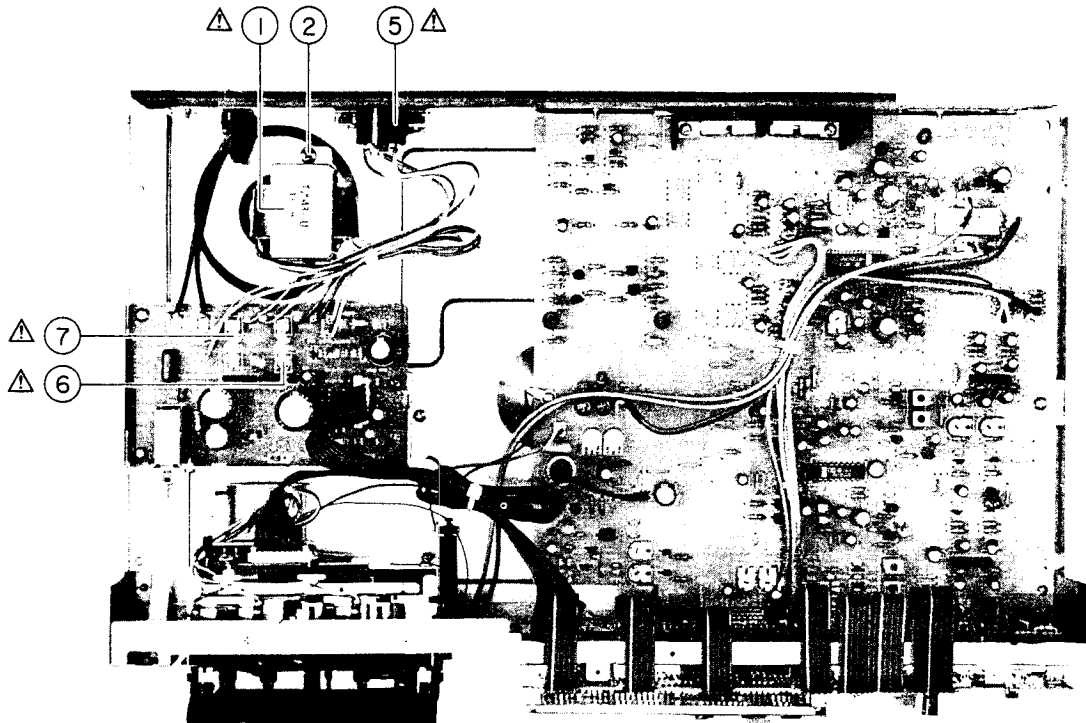

6. ASSEMBLY BLOCK

REF. NO.	PARTS NO.	DESCRIPTION	REF. NO.	PARTS NO.	DESCRIPTION
6-1U	BT-347665	△ TRANS POWER T2043-U (T901)(U)	6-6U	EF-306124	△ FUSE TSC A 250V 0.63A (F1)(U)
6-1C	BT-347667	△ TRANS POWER T2043-AC (T901)(C, A)	6-6C	EF-305703	△ FUSE TSC 125V 0.63A (F1)(C, A)
6-1E	BT-347668	△ TRANS POWER T2043-EV (T901)(E, V)	6-6E	EF-601942	△ FUSE SEMKO T 250V 0.63A (F1)(E, V, B, S)
6-1B	BT-347669	△ TRANS POWER T2043-BS (T901)(B, S)	6-7U	EF-306124	△ FUSE TSC A 250V 0.63A (F2)(U)
6-2	ZS-301398	ST BID40×08STL CMT	6-7C	EF-305703	△ FUSE TSC 125V 0.63A (F2)(C, A)
6-3x	ZW-413188	N40STL CMT 1	6-7E	EF-593706	△ FUSE SEMKO T 250V 0.50A (F2)(E, V, B, S)
6-4U	EW-347601	△ AC CORD 2 CORES KP-205A VFF-CB U/T (U)	6-8U	SP-344636A	PANEL REAR BOARD HX-2 (U)
6-4C	EW-347600	△ AC CORD 2 CORES KP-8, SPT-1-CB UC (C, A)	6-8C	SP-344636C	PANEL REAR BOARD HX-2 (A, C)
6-4E	EW-347602	△ AC CORD 2 CORES KP-419C, LTCE-2F EV (E, V)	6-8E	SP-344636D	PANEL REAR BOARD HX-2 (E)
6-4B	EW-347679	△ AC CORD 2 CORES LTB S-2F-CB B (B)	6-8V	SP-344636E	PANEL REAR BOARD HX-2 (V)
6-4S	EW-347603	△ AC CORD 2 CORES KP-560, LTS2F-CB S (S)	6-8B	SP-344636F	PANEL REAR BOARD HX-2 (B, S)
6-5	ES-305733	△ SW SELECTOR HXW0131-260 01-4 (U ONLY)	6-9	ZS-346048	T2BR30×08STL BNI C080
			6-10x	ZW-305013	RV POP32 (A ONLY)
			6-11	S-A-343007	FOOT

FINAL ASSEMBLY BLOCK

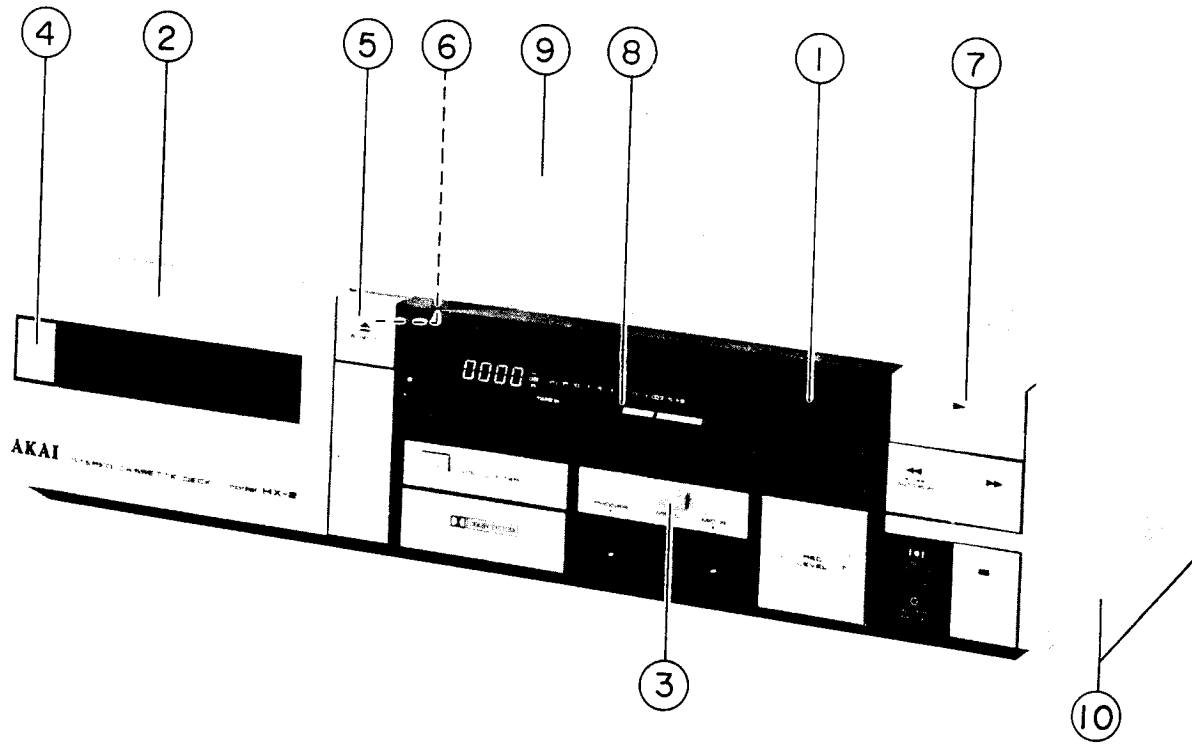

7. FINAL ASSEMBLY BLOCK

REF NO.	PARTS NO.	DESCRIPTION
7-1	BD-B345110A	PANEL FRONT HX-2 PART
7-1P	BD-B345110B	PANEL FRONT HX-2-P PART
7-2	BD-B344571C	LID PANEL (2) PART
7-2P	BD-B344571D	LID PANEL (2)-P PART
7-3	SK-345105C	KNOB DOLBY (C)
7-3P	SK-345105F	KNOB DOLBY (C)-P
7-4	SK-343017C	KNOB POWER (I)
7-4P	SK-343017B	KNOB POWER-P
7-5	SK-344578A	KNOB (A)
7-5P	SK-344578B	KNOB (A) P
7-6	ZG-344749	SP PUSH KNOB (A)
7-7	SK-345103A	KNOB OPERATE (A)
7-7P	SK-345103B	KNOB OPERATE (A)-P
7-8	SE-345106	WINDOW METER
7-9	SP-344591A	COVER UPPER
7-9P	SP-344591B	COVER UPPER P
7-10	ZS-343159	T2BR30×06STL N13
7-10P	ZS-447761	T2BR30×06STL BNI

SYMBOL FOR COLOR VARIATION

NONE – SILVER

P PEARL SHADOW

II. MODEL HX-3

RECOMMENDED SPARE PARTS

Because, if the parts listed below are on hand, almost any repair can be accomplished, we suggest that you stock these Recommended Spare Parts Items.

REF. NO.	PARTS NO.	DESCRIPTION	REF. NO.	PARTS NO.	DESCRIPTION
1	BM-B314815	MOTOR (PULLEY) PART HX-M5	71	EV-315413	R S-FIX H D8 3P 503
2	BT-347628	Δ TRANS POWER T2044-AC (C. A)	72	EV-336785	R S-FIX H TM8KV2-1S 3P0.50W 104
3	BT-347630	Δ TRANS POWER T2044-BS (B. S)	73	HE-337047	HEAD E HJ213270 C
4	BT-347629	Δ TRANS POWER T2044-EV (E. V)	74	HP-344252	HEAD R P HN424977
5	BT-347627	Δ TRANS POWER T2044-U (U)	75	MB-344231	BELT 1.0XD33.3CR HS60
6	EC-344480	C COMP 05-0009	76	MB-344905	BELT 1.2XD38.2 CR HS60
7	ED-330319	Δ D SILICON DBA10B 100/1.0A	77	MB-344230	BELT 3.0x0.5TXD61CRHS60
8	ED-308953	D GERMA H 1K34A-LH S12	78	MI-B344207	ARM IDLER FR PART
9	ED-337010	D LED SLF201C GRN	79	MI-B344215	ARM IDLER TU PART
10	ED-301911	D SILICON H DS448	80	MI-B344288	FLYWHEEL PART
11	ED-337575	D SILICON H GMA-01-4-BT T26	81	MP-336153	PINCH ROLLER (A)
12	ED-306109	D SILICON W03B 100/1.0A			
13	ED-337868	D ZENER V HZ20-3S1			
14	ED-346286	D ZENER V HZ3C-3S1			
15	ED-336998	D ZENER V HZ6B-2S1			
16	ED-345822	D ZENER V HZ6C-3S1			
17	ED-345821	D ZENER V HZ7A-1S1			
18	ED-348037	D ZENER V HZ9A-2S1			
19	EF-601942	Δ FUSE SEMKO T 250V 0.63A (Fl. 2) (E. V. B. S)			
20	EF-306124	Δ FUSE TSC A 250V 0.63A (Fl. 2) (U)			
21	EF-305703	Δ FUSE TSC 125V 0.63A (Fl. 2) (C. A)			
22	EI-337845	IC BA6146 M			
23	EI-345765	IC LB1292			
24	EI-337009	IC LC4049B			
25	EI-345759	IC LC7530			
26	EI-344277	IC LM6405H-145			
27	EI-337228	IC M5218L0			
28	EI-300042	IC M54519P			
29	EI-337835	IC NE652			
30	EI-344291	IC NE654			
31	EI-337017	OSC CE CSB800A 0.800000MHz			
32	EM-347643	IND FL FIP32AW11Y			
33	EO-347162	COIL FIX 1 L-8 10MHz J			
34	EO-337044	COIL FIX 2 102AK-005 36MH			
35	EO-349043	COIL OSC 1 0365-056A 100kHz			
36	EO-315758	COIL TUN 1 100S-431 100.00kHz			
37	EP-337067	RELAY LEAD LAB2NS 2NO 18V			
38	EP-344251	SOLENO ID 0730PLT 12V			
39	ER-318248	Δ R FUSE ERD2FC S10 1/4W 47ROG			
40	ER-307565	Δ R FUSE ERD2FC S10 1/4W 6R8J			
41	ER-337695	FILTER DB 201AK-005 100kHz			
42	ER-337696	FILTER DB 201AK-006 19kHz			
43	ER-347164	R COMP RKC 1/8 B8 223J			
44	ES-344270	Δ SW PUSH SDLD1P 01-1			
45	ES-305733	Δ SW SELECTOR HXW0131-260 01-4			
46	ES-344253	SW LEAF MSW-1418J 01-1 NO			
47	ES-344257	SW LEAF MSW-1418L 01-1 NO			
48	ES-337843	SW PUSH ESB-64501 02-2			
49	ES-345838	SW SLIDE 00230745 2-02-03N			
50	ES-336780	SW TACT KHH10902			
51	ET-310833	Δ TR 2SC2274K E			
52	ET-200505	Δ TR 2SC2603 E. F			
53	ET-310148	Δ TR 2SD612K E. F			
54	ET-307349	Δ TR 2SD794 P. Q			
55	ET-318239	Δ TR 2SD863 E. F			
56	ET-201580	Δ TR 2SD894			
57	ET-311977	PHOTO SENSOR SPI-201			
58	ET-200558	TR 2SA1115 E. F			
59	ET-332422	TR 2SB774 Q. R. S			
60	ET-517263	TR 2SC1312R G. H			
61	ET-337258	TR 2SC 1843 E. F			
62	ET-328578	TR 2SC2320 E. F			
63	ET-344275	TR 2SC2320L F. G			
64	ET-200505	TR 2SC2603 E. F			
65	ET-200985	TR 2SC2603 F. G			
66	ET-332421	TR 2SD1010 R. S			
67	ET-328868	TR 2SD1012-V G. H			
68	EV-315416	R S-FIX H D8 3P 103			
69	EV-315414	R S-FIX H D8 3P 203			
70	EV-322413	R S-FIX H D8 3P 302			

MECHA CMS01 BLOCK (1/2)

1. MECHA CMS01 BLOCK (1/2)

REF. NO.	PARTS NO.	DESCRIPTION
HEAD BLOCK		
I-1	BH-T2051A030B	HEAD BLK HX-2
I-2	ZG343104	SP PUSH EH
I-3	ZG-344900	SP PUSH PB (B)
I-4	ZS-417328	BID23x10STL CMT
I-5	ZS-565211	BID20x10STL NI3
I-6	HP-344252	HEAD R/P HN424977 (H901)
I-7	HE-337047	HEAD E HJ213270 C (H902)
PINCH ROLLER (A) BLOCK		
I-8	BL-T2051A040A	PINCH ROLLER (A) BLK HX-M5
I-9	MP-336153	PINCH ROLLER (A)
HOLDER DETECTION BLOCK		
I-10	ES-344253	SW LEAF MSW-1418J 01-1 NO (SW901, 902)
I-11	ES-344257	SW LEAF MSW-1418L 01-1 NO (SW903)
I-12	ZG-312995	SP T1-40/0.4-11.2 T1-108
MECHA CMS01 BLOCK		
I-13x	BB-T2051A020B	MECHA CMS01 BLK HX-2
I-14	MT-344187	REEL TABLE
I-15	ZG-344188	SP PUSH REEL TABLE
I-16	MT-344190	REEL RETAINER
I-17	MT-305793	REEL CAP
I-18	ZW-305546	PW21x040x025PSL
I-19	ML-344191	LEVER BRAKE (L)
I-20	ML-344192	LEVER BRAKE (R)
I-21	ZG-344194	SP TORSION BRAKE
I-22	MZ-344906	GEAR FF (B)
I-23	ZW-343120	PW17x040x025PSL
I-24	ML-344196	LEVER (A)
I-25	ZG-344200	SP PULL HEAD CHASSIS
I-26	ML-344197	LEVER (B)
I-27	TC-344198	LEVER EJECT STOPPER
I-28	ZG-344199	SP TORSION EJECT LOCK
I-29	MV-357208	BALL200STL
I-30	BD-B344206X1	LID DECORATION PART
I-31	ED-337010	D LED SLF201C GRN
I-32	TC-344236	LEVER EJECT
I-33	ZG-312925	SP T1-3.2/0.2-14.0 T1-042
I-34	MZ-344297	DUMPER ASSY
I-35	SE-344239	LID HOLDER
I-36	ZG-336615	SP PLATE CASSETTE HOLDER (B)
I-37	ZG-344240	SP TORSION LID HOLDER
I-38	MZ-B344179	MECHA CHASSIS PART

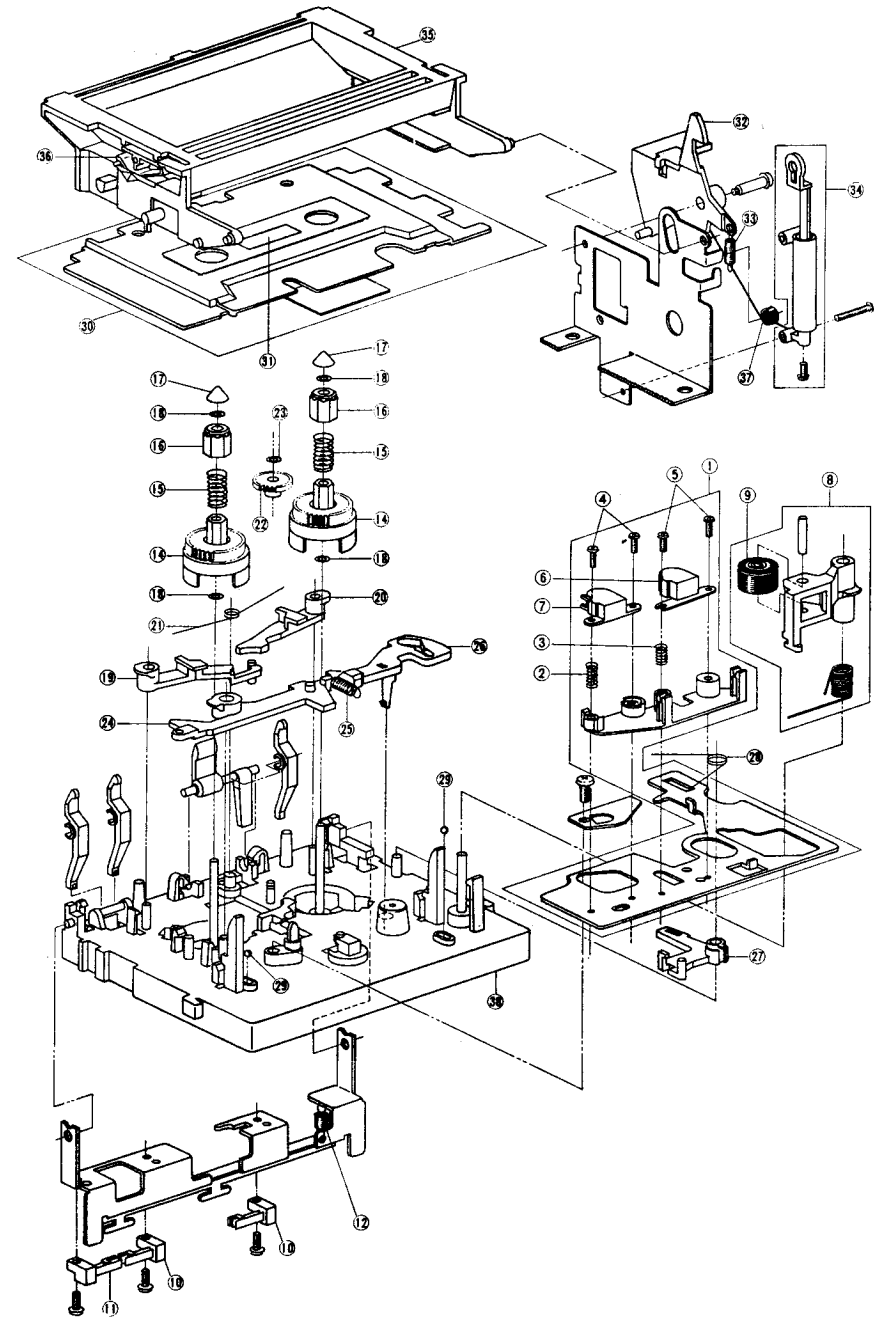

MECHA CMS01 BLOCK (2/2)

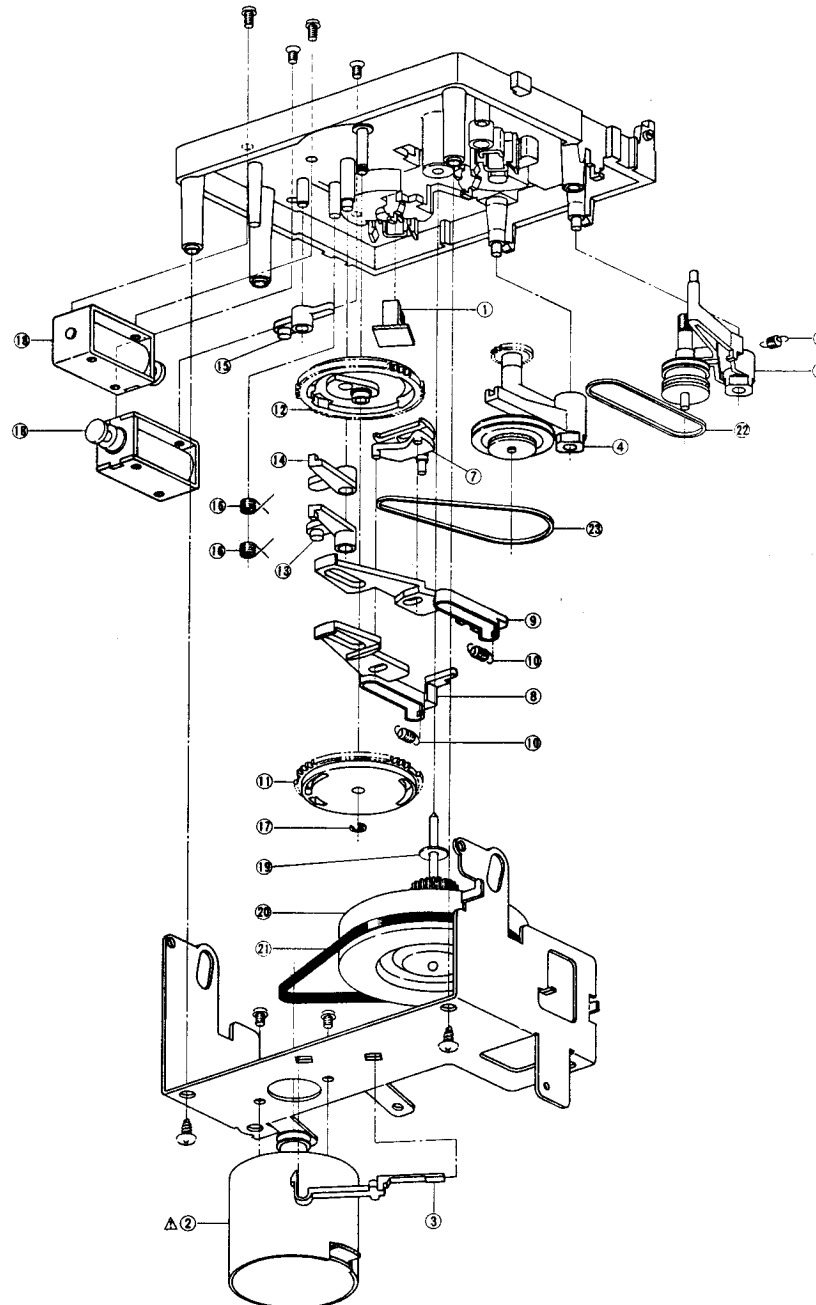

2. MECHA CMS01 BLOCK (2/2)

REF. NO.	PARTS NO.	DESCRIPTION
DETECTOR P. C BOARD		
2-1	ET-311977	PHOTO SENSOR SPI-201 (PH1)
HOLDER MOTOR BLOCK		
2-2	BM-B314815	△ MOTOR (PULLEY) PART
2-3	TC-344901	HOLDER THRUST HX-M5 (M901)
MECHA CMS01 BLOCK		
2-4	MI-B344207	ARM IDLER FR PART
2-5	MI-B344215	ARM IDLER TU PART
2-6	ZG-343152	SP PULL TU IDLER
2-7	TC-344219	CAM SHIFTER
2-8	SK-344220	SLIDE (F)
2-9	TC-344221	SLIDE (R)
2-10	ZS-343153	SP PULL SLIDE
2-11	TP-344222	CAM (F)
2-12	TP-344223	CAM (R)
2-13	TC-344224	ARM LOCK (F)
2-14	TC-344225	ARM LOCK (R)
2-15	TC-344226	ARM JOINT
2-16	ZG-344227	SP TORTION PLUNGER
2-17	ZW-340648	RING CSI90STL PKR
2-18	EP-344251	SOLENOID 0730PLT 12V (SL901.902)
2-19	ZW-345389	PW26x080x020NYL
2-20	MI-B344228	FLYWHEEL PART
2-21	MB-344230	BELT 3.0x0.5TxD61CRHS60
2-22	MB-344231	BELT 1.0xD33.3CR HS60
2-23	MB-344905	BELT 1.2xD38.2 CR HS60
CONNECTOR P. C BOARD		
2-D1.2	ED-306109	D SILICON W03B 100/1.0A
2-D3.4	ED-301911	D SILICON H DS448

3. PRE AMP P. C BOARD BLOCK

REF. NO.	PARTS NO.	DESCRIPTION
3-1	BA-T2044A020A	PC PRE AMP BLK HX-3
PRE AMP P. C BOARD		
3-IC1A	EI-337228	IC M5218LO
3-IC2A	EI-344291	IC NE654
3-IC3A	EI-337835	IC NE652
3-TR1A, 2A	ET-328578	TR 2SC2320 E, F
3-TR3A	ET-332421	TR 2SD1010 R, S
3-TR4A	ET-328578	TR 2SC2320 E, F
3-TR5A	ET-201580	△ TR 2SD894
3-TR6A	ET-328868	TR 2SD1012-V G, H
3-TR7A to 13A	ET-328578	TR 2SC2320 E, F
3-TR14A	ET-318239	△ TR 2SD863 E, F
3-TR15A	ET-200505	△ TR 2SC2603 E, F
3-TR16A	ET-200505	TR 2SC2603 E, F
3-TR18A, 19A	ET-200505	TR 2SC2603 E, F
3-TR20A, 21A	ET-310833	△ TR 2SC2274K E
3-TR25A	ET-328868	TR 2SD1012-V G, H
3-TR26A	ET-337258	TR 2SC1843 E, F
3-TR27A	ET-344275	TR 2SC2320L F, G
3-TR28A	ET-328578	TR 2SC2320 E, F
3-TR29A	ET-200985	TR 2SC2603 F, G
3-TR30A, 31A	ET-200558	TR 2SA1115 E, F
3-D1A	ED-346286	D ZENER V HZ3C-3S1
3-D5A, 6A	ED-301911	D SILICON H DS448
3-D7A	ED-308953	D GERMA H 1K34A-LH S12
3-D8A, 9A	ED-301911	D SILICON H DS448
3-VR1A	EV-315414	R S-FIX H D8 3P 203
3-VR2A	EV-322413	R S-FIX H D8 3P 302
3-VR3A	EV-315416	R S-FIX H D8 23P 103
3-VR5A, 6A	EV-315413	R S-FIX H D8 3P 503
3-VR7A	EV-336785	R S-FIX H TM8KV2-1S 3P 0.50W
3-RL1A	EP-337067	RELAY LEAD LAB2NS 2NO 18V ¹⁰⁴
3-L2A	EO-347162	COIL FIX 1 L-8 10MHz J
3-T1A	EO-349043	COIL OSC1 0365-056A 100kHz
3-FL1A	ER-337695	FILTER DB 201AK-005 100kHz
3-FL2A	ER-337696	FILTER DB 201AK-006 19kHz
3-FL3A	EO-337044	COIL FIX 2 102AK-005 36MH
3-FL4A	EO-315758	COIL TUN 1 100S-431 100.00kHz
3-J1A	EJ-347664	PIN J YKC21-5053 P 4P
3-J2A	EJ-346076	KIN J TCS4690-01-1111 P 8P
3-FR1A, 2A	ER-307565	△ R FUSE ERD2FC S10 1/4W
3-FR3A	ER-318248	△ R FUSE ERD2FC S10 1/4W ^{6R8J} 47ROG
3-R4A	ER-326616	R OMF H SNP FS 1W 681J
3-C57A	EC-345817	C PP V F10 APH 272J 630DC
3-C64A	EC-314995	C STY V SNP CQFS 331J 50DC
3-C69A	EC-314990	C STY V SNP CQFS 101J 50DC
3-C79A	EC-321482	C STY V F05 500 271J 50DC
3-C90A	EC-338429	C PP V F03 FPS 103J 100DC
JACK P. C BOARD		
3-J1B	EJ-347631	PHONE J HLJ0527-330 2x2P
3-J2B	EJ-343380	PHONE J 3P HLJ0541-040 6.3

4. SYSCON P. C BOARD BLOCK

REF. NO.	PARTS NO.	DESCRIPTION
4-1	BA-T2044A030A	PC SYSCON BLK HX-3
SYSCON P. C BOARD		
4-IC1A	EI-337009	IC LC4049B
4-IC2A, 3A	EI-345765	IC LB1292
4-IC4A	EI-344277	IC LM6405H-145
4-IC5A	EI-337009	IC LC4049B
4-IC7A	EI-345765	IC LB1292
4-IC8A, 9A	EI-337845	IC BA6146 M
4-D1A to 5A	ED-301811	D SILICON H DS448
4-IN1A	EM-347643	IND FL FIP32AW11Y
4-SW1A to 9A	ES-336780	SW TACT KHH10902
4-SW10A, 11A	ES-337843	SW PUSH ESB-64501 02-2
4-SW12A	ES-345838	SW SLIDE 00230745 2-02-03-N
4-SW13A, 14A	ES-336780	SW TACT KHH10902
4-SR1A, 2A	ER-347164	R COMP RKC 1/8 B8 223J
4-SR3A	EC-344480	C COMP 05-0009
4-X1A	EI-337017	OSC CE CSB800A 0.800000MHz
JUNCTION P. C BOARD		
4-IC1B	EI-300042	IC M54519P
4-IC2B	EI-345759	IC LC7530
4-TR1B, 2B	ET-200558	TR 2SA1115 E, F
4-TR3B	ET-332422	TR 2SB774 Q, R, S
4-TR4B	ET-517263	TR 2SC1312R G, H
4-TR5B to 7B	ET-200558	TR 2SA1115 E, F
4-TR8B, 9B	ET-200505	TR 2SC2603 E, F
4-D1B to 12B	ED-301911	D SILICON H DS448
4-D13B	ED-345821	D ZENER V HZ7A-1S1
4-D14B	ED-348037	D ZENER V HZ9A-2S1

5. POWER SUPPLY P. C BOARD BLOCK

REF. NO.	PARTS NO.	DESCRIPTION
5-TR2	ET-200505	△ TR 2SC2603 E, F
5-TR3	ET-200558	TR 2SA1115 E, F
5-TR4	ET-310148	△ TR 2SD612K E, F
5-TR5	ET-200505	TR 2SC2603 E, F
5-TR6	ET-307349	△ TR 2SD794 P, Q
5-TR7	ET-200505	△ TR 2SC2603 E, F
5-D3	ED-337575	D SILICON H GMA-01-4-BT T26
5-D4	ED-336998	D ZENNER V HZ6B-2S1
5-D5	ED-330319	△ D SILICON DBA10B 100/1.0A
5-D6	ED-306109	D SILICON W03B 100/1.0A
5-D7	ED-345822	D ZENNER V HZ6C-3S1
5-D8	ED-330319	△ D SILICON DBA10B 100/1.0A
5-D9	ED-337868	D ZENNER V HZ20-3S1
5-SW1	ES-344270	△ SW PUSH SLD1P 01-1
5-R10	ER-337778	△ R OMF H S15 FS 1W 122J
5-C1U	EC-346790	△ C MY V ECQEW 333M 250AC (U)
5-C1C	EC-338411	△ C CE V FZ 103P 400AC (EXCEPT U)

ASSEMBLY BLOCK

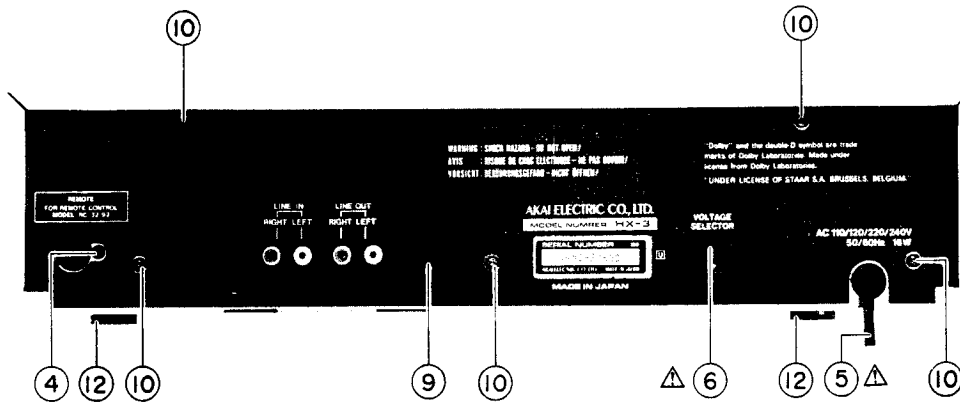
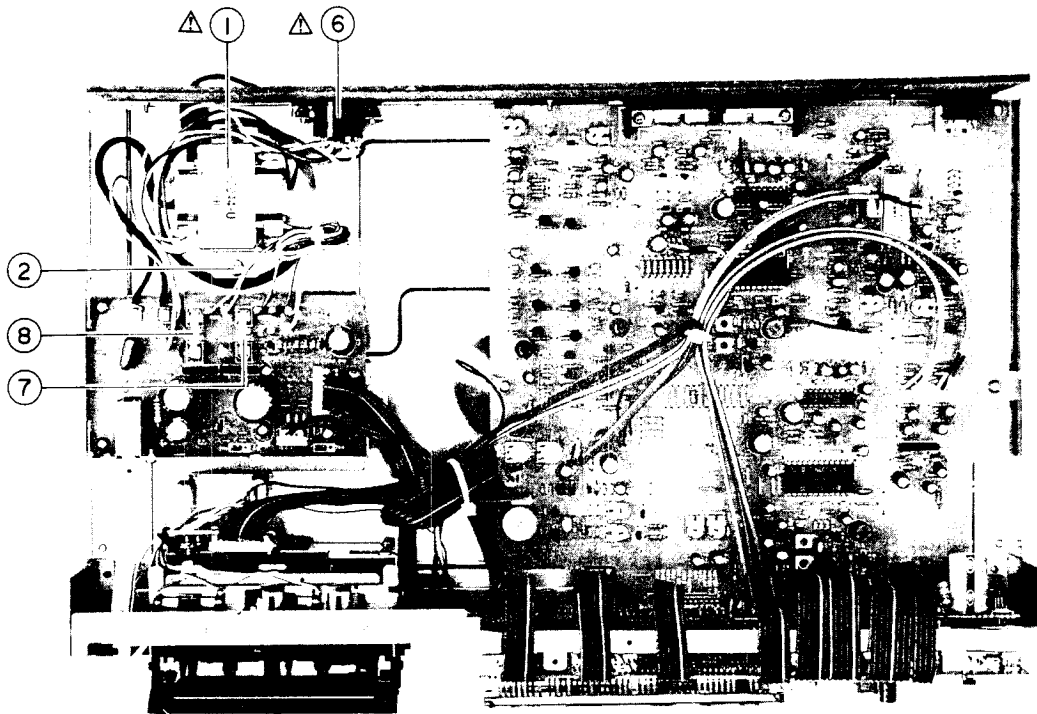

6. ASSEMBLY BLOCK

REF. NO.	PARTS NO.	DESCRIPTION	REF. NO.	PARTS NO.	DESCRIPTION
6-1U	BT-347627	△ TRANS POWER T2044-U (T901) (U)	6-7U	EF-306124	△ FUSE TSC A 250V 0.63A (F1) (U)
6-1C	BT-347628	△ TRANS POWER T2044-AC (T901) (C, A)	6-7C	EF-305703	△ FUSE TSC 125V 0.63A (F1) (C, A)
6-1E	BT-347629	△ TRANS POWER T2044-EV (T901) (E, V)	6-7E	EF-601942	△ FUSE SEMKO T 250V 0.63A (F1) (E, V, B, S)
6-1B	BT-347630	△ TRANS POWER T2044-BS (T901) (B, S)	6-8U	EF-306124	△ FUSE TSC A 250V 0.63A (F2) (U)
6-2	ZS-301398	ST BID40x08STL CMT	6-8C	EF-305703	△ FUSE TSC 125V 0.63A (F2) (C, A)
6-3x	ZW-413188	N40STL CMT 1	6-8E	EF-601942	△ FUSE SEMKO T 250V 0.63A (F2) (E, V, B, S)
6-4	ZW-698308	RV NYL30x055 BL	6-9U	SP-344636G	PANEL REAR BOARD HX-3 (U)
6-5U	EW-347601	△ AC CORD 2 CORES KP-205A VFF-CB U/T (U)	6-9C	SP-344636J	PANEL REAR BOARD HX-3 (C, A)
6-5C	EW-347600	△ AC CORD 2 CORES KP-8, SPT-L-CB UC (C, A)	6-9E	SP-344636K	PANEL REAR BOARD HX-3 (E)
6-5E	EW-347602	△ AC CORD 2 CORES KP-419C, LTCE-2F EV (E, V)	6-9V	SP-344636L	PANEL REAR BOARD HX-3 (V)
6-5B	EW-347679	△ AC CORD 2 CORES KP-419C LTBS-2F-CB B (B)	6-9B	SP-344636M	PANEL REAR BOARD HX-3 (B, S)
6-5S	EW-347603	△ AC CORD 2 CORD KP-560, K TSA2F-CB S (S)	6-10	ZS-346048	T2BR30x08STL BNI C080
6-6	ES-305733	△ SW SELECTOR HXW0131-260 01-4 (VS901) (U)	6-11x	ZW-305013	RV POP32 (A ONLY)
			6-12	SA-343007	FOOT

FINAL ASSEMBLY BLOCK

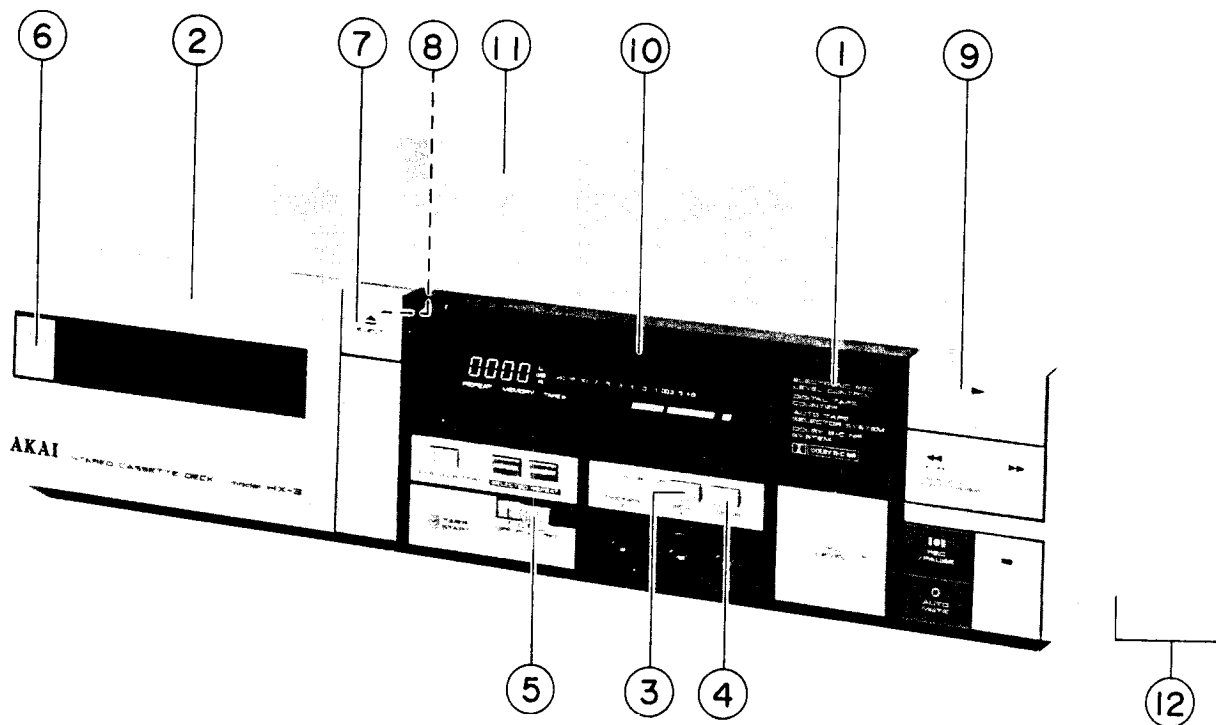

7. FINAL ASSEMBLY BLOCK

REF. NO.	PARTS NO.	DESCRIPTION
7-1	BD-B345102A	PANEL FRONT HX-3 PART
7-1P	BD-B345102B	PANEL FRONT HX-3-P PART
7-2	BD-B344571E	LID PANEL (3) PART
7-2P	BD-B344571F	LID PANEL (3)-P PART
7-3	SK-345105A	KNOB DOLBY (A)
7-3P	SK-345105D	KNOB DOLBY (A)-P
7-4	SK-345105B	KNOB DOLBY (B)
7-4P	SK-345105E	KNOB DOLBY (B)-P
7-5	SK-344585A	KNOB SLIDE
7-5P	SK-344585B	KNOB SLIDE P
7-6	SK-343017C	KNOB POWER (2)
7-6P	SK-343017B	KNOB POWER-P
7-7	SK-344578A	KNOB (A)
7-7P	SK-344578B	KNOB (A)-P
7-8	ZG-344749	SP PUSH KNOB (A)
7-9	SK-345103A	KNOB OPERATE (A)
7-9P	SK-345103B	KNOB OPERATE (A)-P
7-10	SE-345106	WINDOW METER
7-11	SP-344591A	COVER UPPER
7-11P	SP-344591B	COVER UPPER P
7-12	ZS-343159	T2BR30x06STL N13
7-12P	ZS-447761	T2BR30x06STL BNI

SYMBOL FOR COLOR VARIATION

NONE - SILVER

P PEARL SHADOW

INDEX

1. HX-2

PARTS NO.	REF. NO.	PARTS NO.	REF. NO.	PARTS NO.	REF. NO.	PARTS NO.	REF. NO.
BA-T2043A020A	3-1	EI-347634	3-IC3A	EW-347602	6-4E		
BA-T2043A030A	4-1	EI-347635	3-IC4A	EW-347603	6-4S		
BB-T2051A020B	1-13x	EJ-343380	3-J2B	EW-347679	6-4B		
BD-B344206X1	1-30	EJ-347631	3-J1B	HE-337047	1-7		
BD-B344571C	7-2	EJ-347664	3-J1A	HP-344252	1-6		
BD-B344571D	7-2P	EM-347643	4-IN1A	MB-344236	2-21		
BD-B345110A	7-1	EO-337523	3-FL4A	MB-344231	2-22		
BD-B345110B	7-1P	EO-337774	3-T1A	MB-344905	2-23		
BH-T2051A030B	1-1	EO-348235	3-FL3A	MI-B344207	2-4		
BL-T2051A040A	1-8	EP-337067	3-RL1A	MI-B344215	2-5		
BM-B314815	2-2	EP-344251	2-18	MI-B344228	2-20		
BT-347665	6-1U	ER-307565	3-FR2A	ML-344191	1-19		
BT-347667	6-1C	ER-307565	3-FR1A	ML-344192	1-20		
BT-347668	6-1E	ER-337695	3-FL1A	ML-344196	1-24		
BT-347669	6-1B	ER-337696	3-FL2A	ML-344197	1-26		
EC-306017	3-C34A	ER-337778	5-R10	MP-B336153	1-9		
EC-306017	3-C48A	ER-347164	4-SR2A	MT-305793	1-17		
EC-306022	3-C65A	ER-347164	4-SR1A	MT-344187	1-14		
EC-310440	3-C31A	ES-305733	6-5	MT-344190	1-16		
EC-319949	3-C91A	ES-336780	4-SW1A	MV-357208	1-29		
EC-323846	5-C10	ES-336780	4-SW3A	MZ-B344179	1-38		
EC-333996	3-C9A	ES-336780	4-SW4A	MZ-344297	1-34		
EC-337966	3-C68A	ES-336780	4-SW5A	MZ-344906	1-22		
EC-338411	5-C1C	ES-336780	4-SW6A	SA-343007	6-11		
EC-344480	4-SR3A	ES-336780	4-SW7A	SE-344239	1-35		
EC-345817	3-C67A	ES-336780	4-SW8A	SE-345106	7-8		
EC-346790	5-C1U	ES-336780	4-SW9A	SK-343017B	7-4P		
ED-301911	2-D3	ES-336780	4-SW2A	SK-343017C	7-4		
ED-301911	2-D4	ES-337843	4-SW10A	SK-344220	2-8		
ED-301911	3-D2A	ES-344253	1-10	SK-344578A	7-5		
ED-301911	3-D4A	ES-344257	1-11	SK-344578B	7-5P		
ED-301911	3-D7A	ET-200505	3-TR6A	SK-345103A	7-7		
ED-301911	3-D12A	ET-200505	3-TR7A	SK-345103B	7-7P		
ED-301911	3-D13A	ET-200505	3-TR12A	SK-345105C	7-3		
ED-301911	3-D11A	ET-200505	3-TR13A	SK-345105F	7-3P		
ED-301911	4-D1A	ET-200505	3-TR17A	SP-344591A	7-9		
ED-301911	4-D3B	ET-200505	3-TR24A	SP-344591B	7-9P		
ED-301911	4-D4B	ET-200505	3-TR28A	SP-344636A	6-8U		
ED-301911	4-D5B	ET-200505	3-TR29A	SP-344636C	7-8C		
ED-301911	4-D6B	ET-200505	3-TR30A	SP-344636D	6-8E		
ED-301911	4-D7B	ET-200505	3-TR31A	SP-344663E	6-8V		
ED-301911	4-D8B	ET-200505	4-TR8B	SP-344636F	6-8B		
ED-301911	4-D9B	ET-200505	5-TR2	TC-344198	1-27		
ED-301911	4-D10B	ET-200505	5-TR5	TC-344219	2-7		
ED-301911	4-D11B	ET-200505	5-TR7	TC-344221	2-9		
ED-301911	4-D12B	ET-200558	3-TR11A	TC-344224	2-13		
ED-301911	4-D15B	ET-200558	3-TR10A	TC-344225	2-14		
ED-306109	2-D1	ET-200558	4-TR1B	TC-344226	2-15		
ED-306109	2-D2	ET-200558	4-TR5B	TC-344236	1-32		
ED-306109	5-D6	ET-200558	4-TR6B	TC-344901	2-3		
ED-308952	3-D3A	ET-200558	4-TR7B	TP-344222	2-11		
ED-330319	5-D5	ET-200558	5-TR3	TP-344223	2-12		
ED-330319	5-D8	ET-307349	5-TR6	ZG-312925	1-33		
ED-336998	5-D4	ET-309353	3-TR25A	ZG-312995	1-12		
ED-337010	1-31	ET-309353	3-TR26A	ZG-336615	1-36		
ED-337575	5-D3	ET-310148	5-TR4	ZG-343104	1-2		
ED-337868	5-D9	ET-311977	2-1	ZG-343152	2-6		
ED-345027	3-D1A	ET-318239	3-TR5A	ZG-344188	1-15		
ED-345821	4-D13B	ET-318239	3-TR16A	ZG-344194	1-21		
ED-345822	5-D7	ET-318239	3-TR27A	ZG-344199	1-28		
ED-346286	3-D5A	ET-328578	3-TR3A	ZG-344200	1-25		
EF-305703	6-6C	ET-328578	3-TR4A	ZG-344227	2-16		
EF-305703	6-7C	ET-328578	3-TR8A	ZG-344240	1-37		
EF-306124	6-6U	ET-328578	3-TR9A	ZG-344749	7-6		
EF-306124	6-7U	ET-328578	3-TR14A	ZG-344900	1-3		
EF-593706	6-7E	ET-328578	3-TR20A	ZS-301398	6-2		
EF-601942	6-6E	ET-328578	3-TR19A	ZS-343153	2-10		
EI-300042	4-IC1B	ET-328868	3-TR1A	ZS-343159	7-10		
EI-337009	4-IC1A	ET-328868	3-TR2A	ZS-346048	6-9		
EI-337009	4-IC5A	ET-332422	4-TR3B	ZS-417328	1-4		
EI-337017	4-X1A	ET-337258	3-TR15A	ZS-447761	7-10P		
EI-337228	3-IC1A	ET-517263	4-TR4B	ZS-565211	1-5		
EI-337228	3-IC2A	EV-315413	3-VR1A	ZW-305013	6-10x		
EI-337845	4-IC8A	EV-315413	3-VR3A	ZW-305546	1-18		
EI-337845	4-IC9A	EV-315416	3-VR2A	ZW-340648	2-17		
EI-344277	4-IC4A	EV-315416	3-VR5A	ZW-343120	1-23		
EI-345759	4-IC2B	EV-322413	3-VR6A	ZW-345389	2-19		
EI-345765	4-IC2A	EV-336785	3-VR4A	ZW-413188	6-3x		
EI-345765	4-IC3A	EW-347600	6-4C				
EI-345765	4-IC7A	EW-347601	6-4U				

INDEX

2. HX-3

PARTS NO.	REF. NO.	PARTS NO.	REF. NO.	PARTS NO.	REF. NO.	PARTS NO.	REF. NO.
BA-T2044A020A	3-1	EJ-343386	3-J2B	ET-517263	4-TR4B	ZS-343159	7-12
BA-T2044A030A	4-1	EJ-346076	3-J2A	EV-315413	3-VR5A	ZS-346048	6-10
BB-T2051A020B	1-13x	EJ-347631	3-J1B	EV-315413	3-TR6A	ZS-417328	1-4
BD-B344206X1	1-30	EJ-347664	3-J1A	EV-315414	3-VR1A	ZS-447761	7-12P
BD-B344571E	7-2	EM-347643	4-IN1A	EV-315413	3-VR3A	ZS-565211	1-5
BD-B344571F	7-2P	EO-315758	3-FL4A	EV-322413	3-VR2A	ZW-305013	6-11x
BD-B345102A	7-1	EO-337044	3-FL3A	EV-336785	3-VR7A	ZW-305546	1-18
BD-B345102B	7-1P	EO-347162	3-L2A	EW-347600	6-5C	ZW-340648	2-17
BH-T2051A030B	1-1	EO-349043	3-T1A	EW-347601	6-5U	ZW-343120	1-23
BL-T2051A040A	1-8	EP-337067	3-RL1A	EW-347602	6-5E	ZW-345389	2-19
BM-B314815	2-2	EP-344251	2-18	EW-347603	6-5S	ZW-413188	6-3x
BT-347627	6-1U	ER-307565	3-FR2A	EW-347679	6-5B	ZW-698308	6-4
BT-347628	6-1C	ER-307565	3-FR1A	HE-337047	1-7		
BT-347629	6-1E	ER-318248	3-FR3A	HP-344252	1-6		
BT-347630	6-1B	ER-326616	3-R4A	MB-344230	2-21		
EC-314990	3-C69A	ER-337695	3-FL1A	MB-344231	2-22		
EC-314995	3-C64A	ER-337695	3-FL2A	MB-344905	2-23		
EC-321482	3-C79A	ER-337778	5-R10	MI-B344207	2-4		
EC-338411	5-C1C	ER-347164	4-SR1A	MI-B344215	2-5		
EC-338429	3-C90A	ER-347164	4-SR2A	MI-B344228	2-20		
EC-344480	4-SR3A	ES-305733	6-6	ML-344191	1-19		
EC-345817	3-C57A	ES-336780	4-SW14A	ML-344192	1-20		
EC-346790	5-C1U	ES-336780	4-SW4A	ML-344196	1-24		
ED-301911	2-D3	ES-336780	4-SW1A	ML-344197	1-26		
ED-301911	2-D4	ES-336780	4-SW2A	MP-336153	1-9		
ED-301911	3-D5A	ES-336780	4-SW3A	MT-305793	1-17		
ED-301911	3-D6A	ES-336780	4-SW5A	MT-344187	1-14		
ED-301911	3-D8A	ES-336780	4-SW6A	MT-344190	1-16		
ED-301911	3-D9A	ES-336780	4-SW7A	MV-357208	1-29		
ED-301911	4-D7B	ES-336780	4-SW9A	MZ-B344179	1-38		
ED-301911	4-D9B	ES-336780	4-SW13A	MZ-344297	1-34		
ED-301911	4-D11B	ES-336780	4-SW8A	MZ-344906	1-22		
ED-301911	4-D1A	ES-337843	4-SW11A	SA-343007	6-12		
ED-301911	4-D2A	ES-337843	4-SW10A	SE-344239	1-35		
ED-301911	4-D3A	ES-344253	1-10	SE-345106	7-10		
ED-301911	4-D4A	ES-344257	1-11	SK-343017B	7-6P		
ED-301911	4-D5A	ES-344270	5-SW1	SK-343017C	7-6		
ED-301911	4-D1B	ES-345838	4-SW12A	SK-344220	2-8		
ED-301911	4-D2B	ET-200505	3-TR15A	SK-344578A	7-7		
ED-301911	4-D4B	ET-200505	3-TR16A	SK-344578B	7-7P		
ED-301911	4-D5B	ET-200505	3-TR18A	SK-344585A	7-5		
ED-301911	4-D6B	ET-200505	3-TR19A	SK-344585B	7-5P		
ED-301911	4-D8B	ET-200505	4-TR8B	SK-345103A	7-9		
ED-301911	4-D10B	ET-200505	4-TR9B	SK-345103B	7-9P		
ED-301911	4-D12B	ET-200505	5-TR7	SK-345105A	7-3		
ED-301911	4-D3B	ET-200505	5-TR5	SK-345105B	7-4		
ED-306109	2-D1	ET-200505	5-TR2	SK-345105D	7-3P		
ED-306109	2-D2	ET-200558	3-TR30A	SK-345105E	7-4P		
ED-306109	5-D6	ET-200558	3-TR31A	SP-344591A	7-11		
ED-308953	3-D7A	ET-200558	4-TR5B	SP-344591B	7-11P		
ED-330319	5-D8	ET-200558	4-TR7B	SP-344636G	6-9U		
ED-330319	5-D5	ET-200558	4-TR2B	SP-344636J	6-9C		
ED-336998	5-D4	ET-200558	4-TR1B	SP-344636K	6-9E		
ED-337010	1-31	ET-200558	4-TR6B	SP-344636L	6-9V		
ED-337575	5-D3	ET-200558	5-TR3	SP-344636M	6-9B		
ED-337868	5-D9	ET-200985	3-TR29A	TC-344198	1-27		
ED-345821	4-D13B	ET-201580	3-TR5A	TC-344219	2-7		
ED-345822	5-D7	ET-307349	5-TR6	TC-344221	2-9		
ED-346286	3-D1A	ET-310148	5-TR4	TC-344224	2-13		
ED-348037	4-D14B	ET-310833	3-TR20A	TC-344225	2-14		
EF-305703	6-8C	ET-310833	3-TR21A	TC-344226	2-15		
EF-305703	6-7C	ET-311977	2-1	TC-344236	1-32		
EF-306124	6-8U	ET-318239	3-TR14A	TC-344901	2-3		
EF-306124	6-7U	ET-328578	3-TR10A	TP-344222	2-11		
EF-601942	6-7E	ET-328578	3-TR1A	TP-344223	2-12		
EF-601942	6-8E	ET-328578	3-TR4A	ZG-312925	1-33		
EI-300042	4-IC1B	ET-328578	3-TR7A	ZG-312995	1-12		
EI-337009	4-IC1A	ET-328578	3-TR8A	ZG-336615	1-36		
EI-337009	4-IC5A	ET-328578	3-TR9A	ZG-343104	1-2		
EI-337017	4-X1A	ET-328578	3-TR11A	ZG-343152	2-6		
EI-337229	3-IC1A	ET-328578	3-TR12A	ZG-344188	1-15		
EI-337835	3-IC3A	ET-328578	3-TR13A	ZG-344194	1-21		
EI-337845	4-IC8A	ET-328578	3-TR28A	ZG-344199	1-28		
EI-337845	4-IC9A	ET-328578	3-TR2A	ZG-344200	1-25		
EI-344277	4-IC4A	ET-328868	3-TR6A	ZG-344227	2-16		
EI-344291	3-IC2A	ET-328868	3-TR25A	ZG-344240	1-37		
EI-345759	4-IC2B	ET-332421	3-TR3A	ZG-344749	7-8		
EI-345765	4-IC3A	ET-332422	4-TR3B	ZG-344900	1-3		
EI-345765	4-IC2A	ET-337258	3-TR26A	ZS-301398	6-2		
EI-345765	4-IC7A	ET-344275	3-TR27A	ZS-343153	2-10		

SECTION 3

SCHEMATIC DIAGRAM

TABLE OF CONTENTS

1. SCHEMATIC DIAGRAM OF ICs.....	49
2. HX-2 POWER AND SYSCON NO. 2-1 830707A SCHEMATIC DIAGRAM	53
3. HX-2 AMP NO. 2-2 830708A SCHEMATIC DIAGRAM	54
4. HX-3 POWER AND SYSCON NO. 2-1 830709A SCHEMATIC DIAGRAM	55
5. HX-3 AMP NO. 2-2 830710A SCHEMATIC DIAGRAM	56

1

SCHEMATIC DIAGRAM OF IC's

BA6146

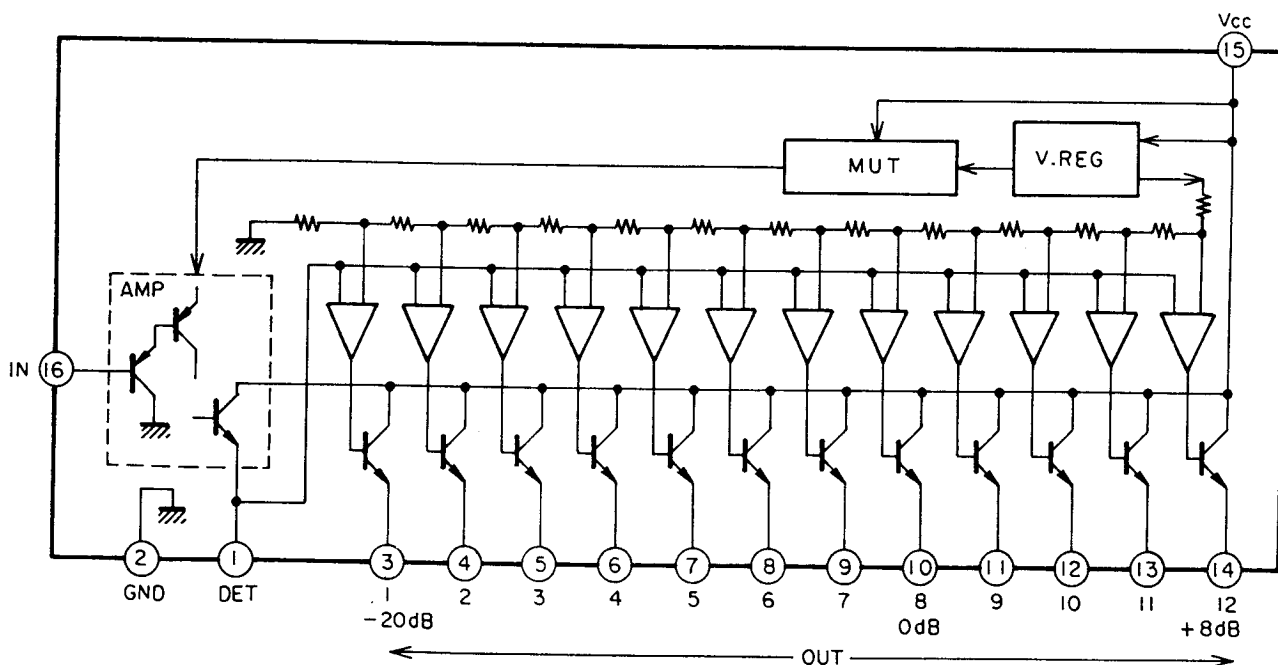

SCHEMATIC DIAGRAM HX-2/HX-3

HA12045

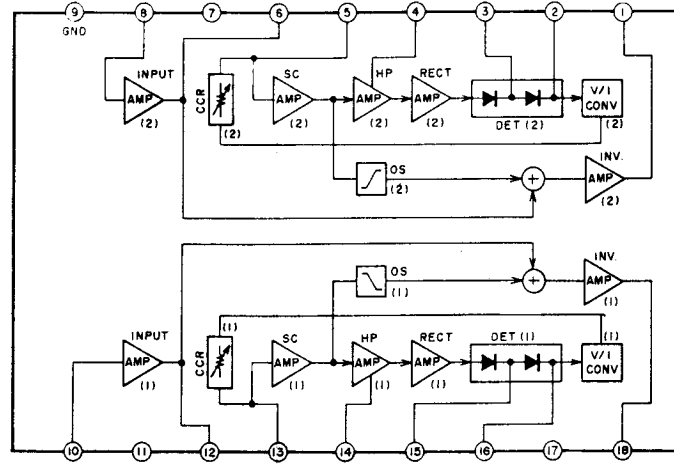

HA12051NT

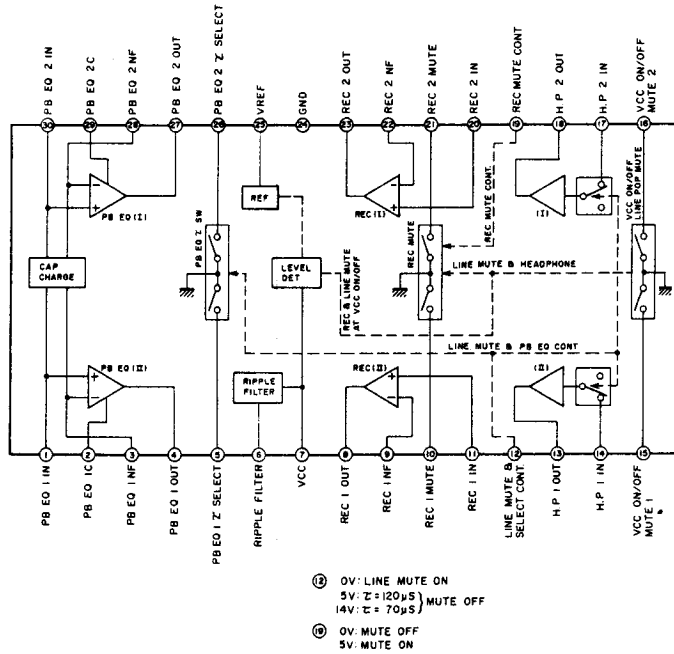

LB1292

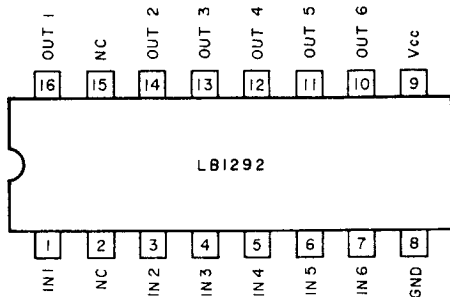
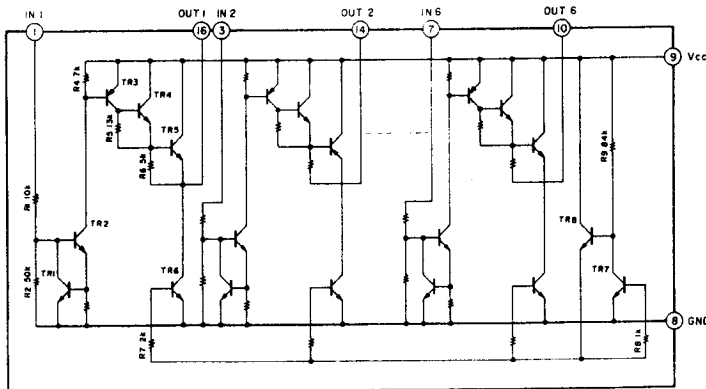

(Top View)

LC4049B

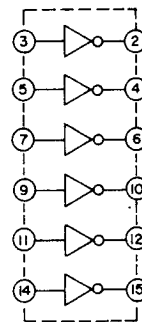

NC= Pin 13,16
VSS= Pin 8
VCC= Pin 1

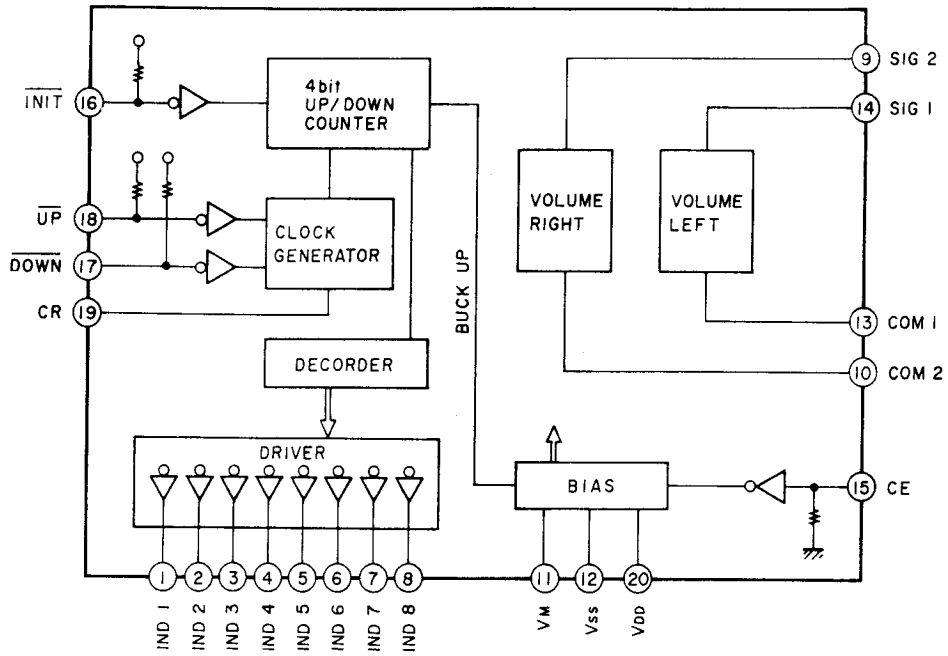

M5218L0

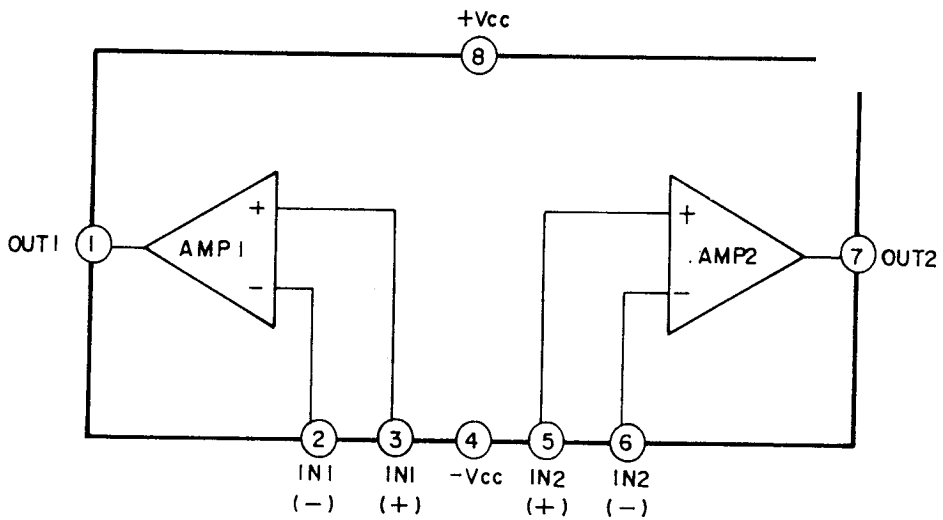

M54519P

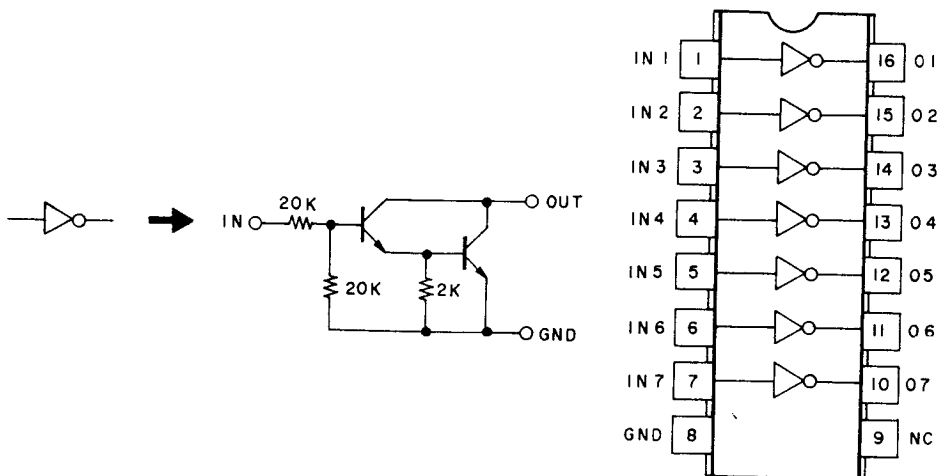

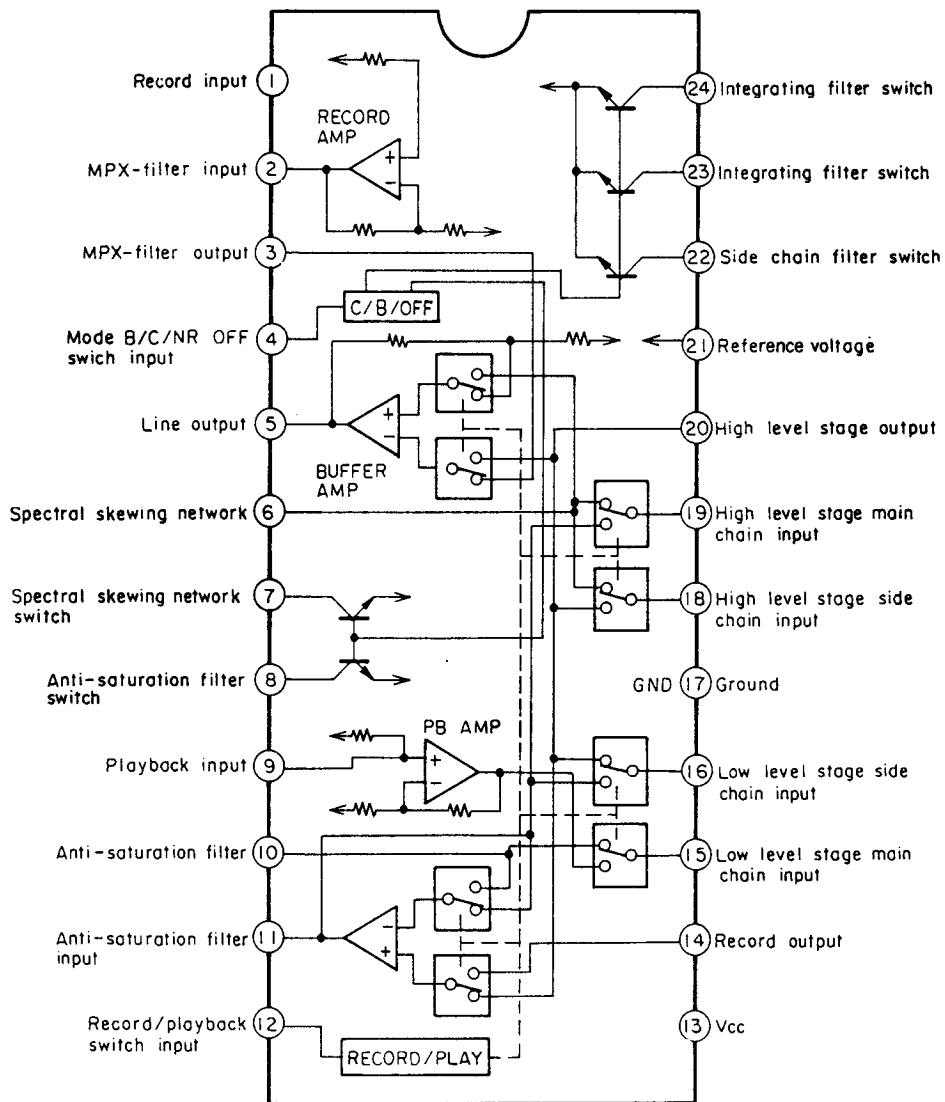
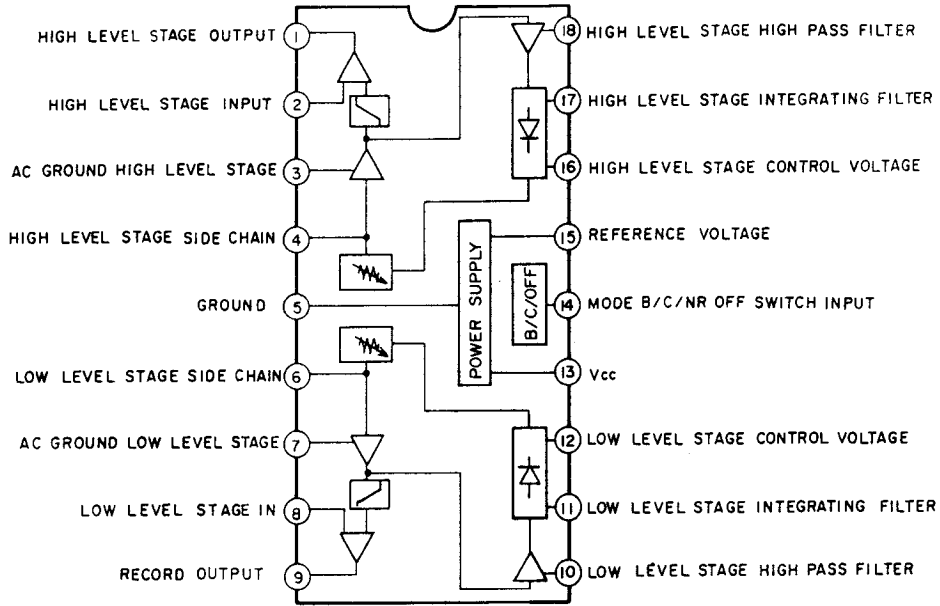

SCHEMATIC DIAGRAM HX-2/HX-3

HX-2

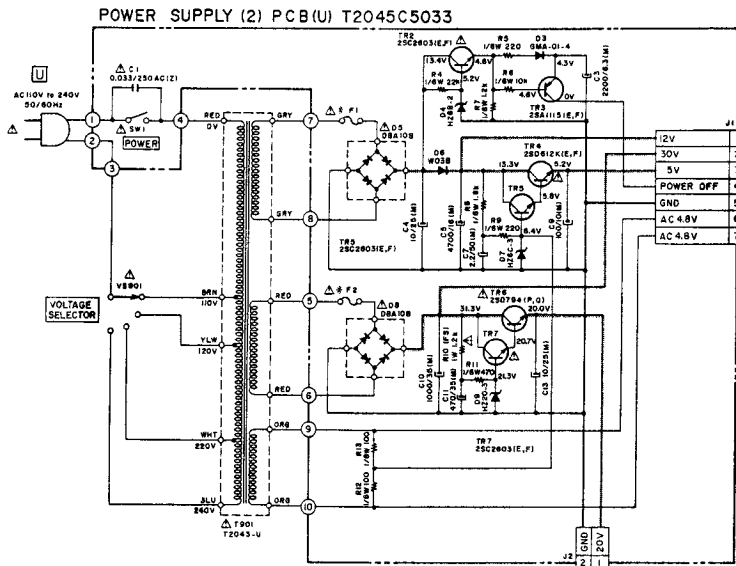
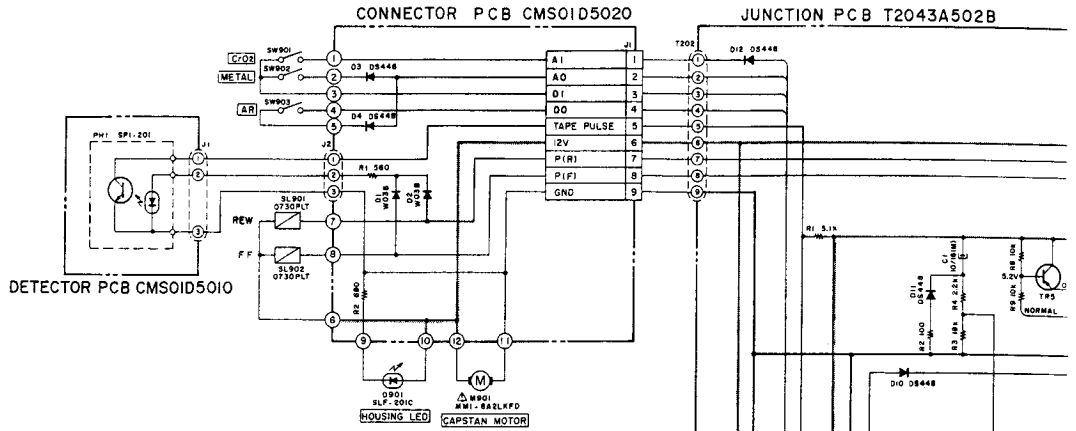

Part	Value	Part	Value
F1	830mA 250V	F2	830mA 250V
F3	830mA 250V	F4	830mA 250V

POWER SUPPLY (3) PCB (E) T2045C5036 E, V, B, S
 POWER SUPPLY (2) PCB (C) T2045C5034 C, A

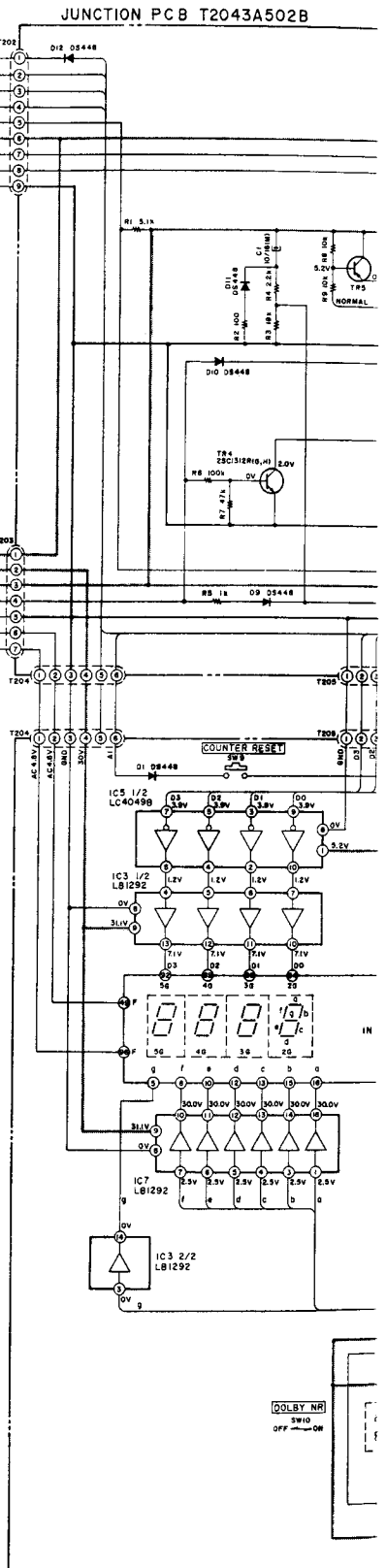
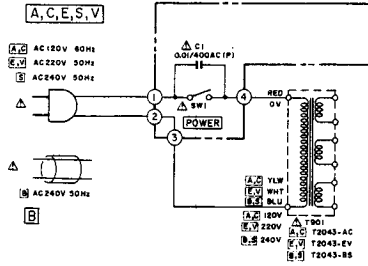

WARNING: Δ INDICATES SAFETY CRITICAL COMPONENTS FOR CONTINUED SAFETY. REPLACE SAFETY CRITICAL COMPONENTS ONLY WITH MANUFACTURER'S RECOMMENDED PARTS.
 AVERTISSEMENT: Δ IL INDIQUE LES COMPOSANTS CRITIQUES DE SECURITE POUR MAINTENIR LE DEGRE DE SECURITE DE L'APPAREIL. NE REMPLACER QUE DES PIECES RECOMMANDEES PAR LE FABRICANT.

SYSTEM CONTROL PCB T2043A502A

CONNECTOR PCB CMS01D5020

JUNCTION PCB T2043A502B

TO PRE AMP P1

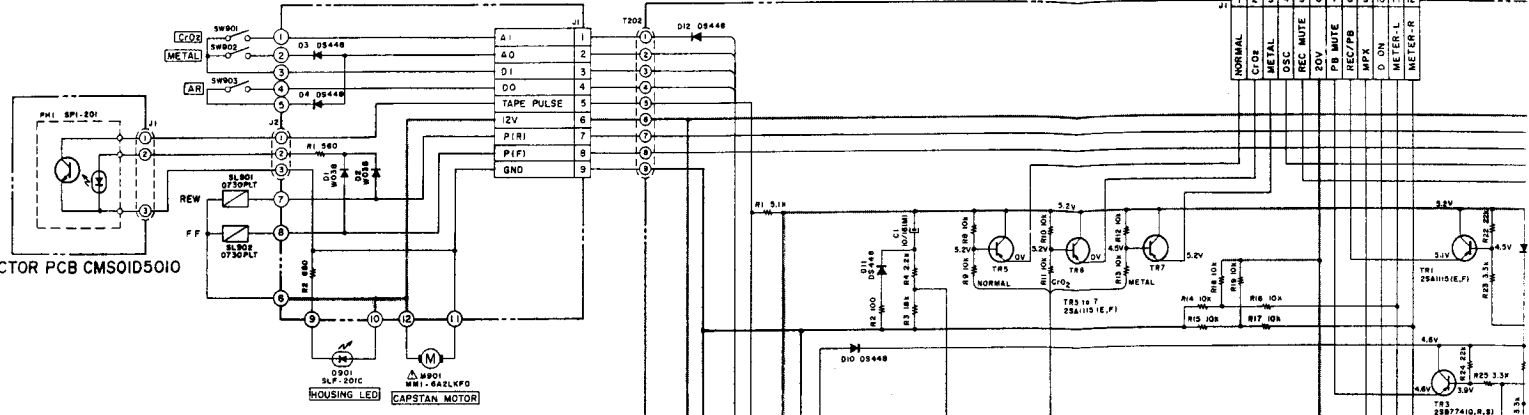

POWER SUPPLY (2) PCB(U) T2045C5033

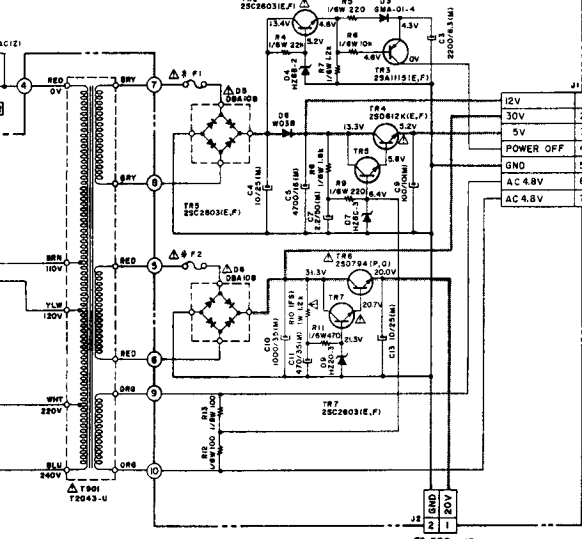

F	U	C-A	E-V-B-S
F1	630MA 250V	630MA 125V	T430MA
F2	630MA 250V	630MA 125V	T500MA

POWER SUPPLY (3) PCB (E) T2045C5036 E,V,B,S
POWER SUPPLY (2) PCB (C) T2045C5034 C,A

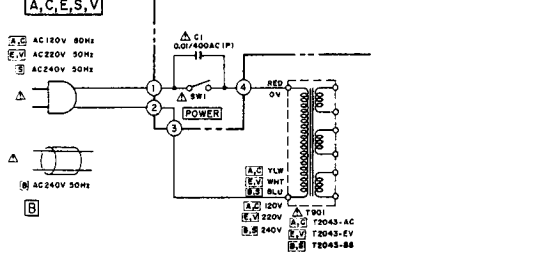

WARNING: Δ INDICATES SAFETY CRITICAL COMPONENTS FOR CONTINUED SAFETY. REPLACE SAFETY CRITICAL COMPONENTS ONLY WITH MANUFACTURER'S RECOMMENDED PARTS.
AVERTISSEMENT: Δ IL INDIQUE LES COMPOSANTS CRITIQUES DE SÉCURITÉ POUR MAINTENIR LE DEGRÉ DE SÉCURITÉ DE L'APPAREIL. NE REMPLACEZ QUE DES PIÈCES RECOMMANDÉES PAR LE FABRICANT.

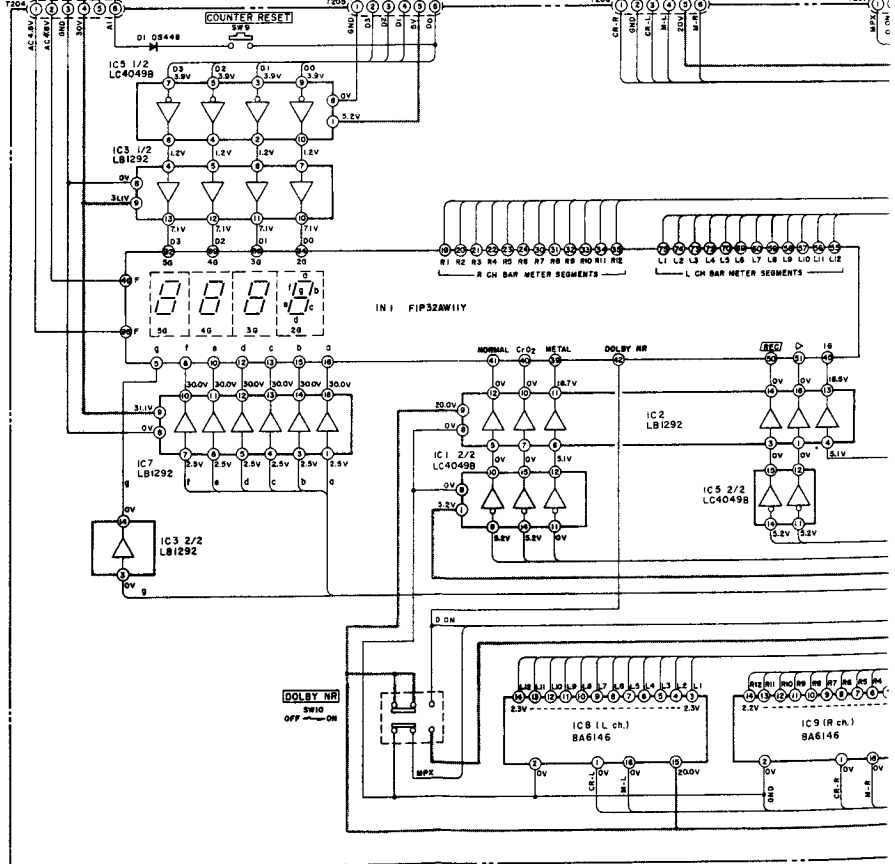

SYSTEM CONTROL PCB T2043A502A



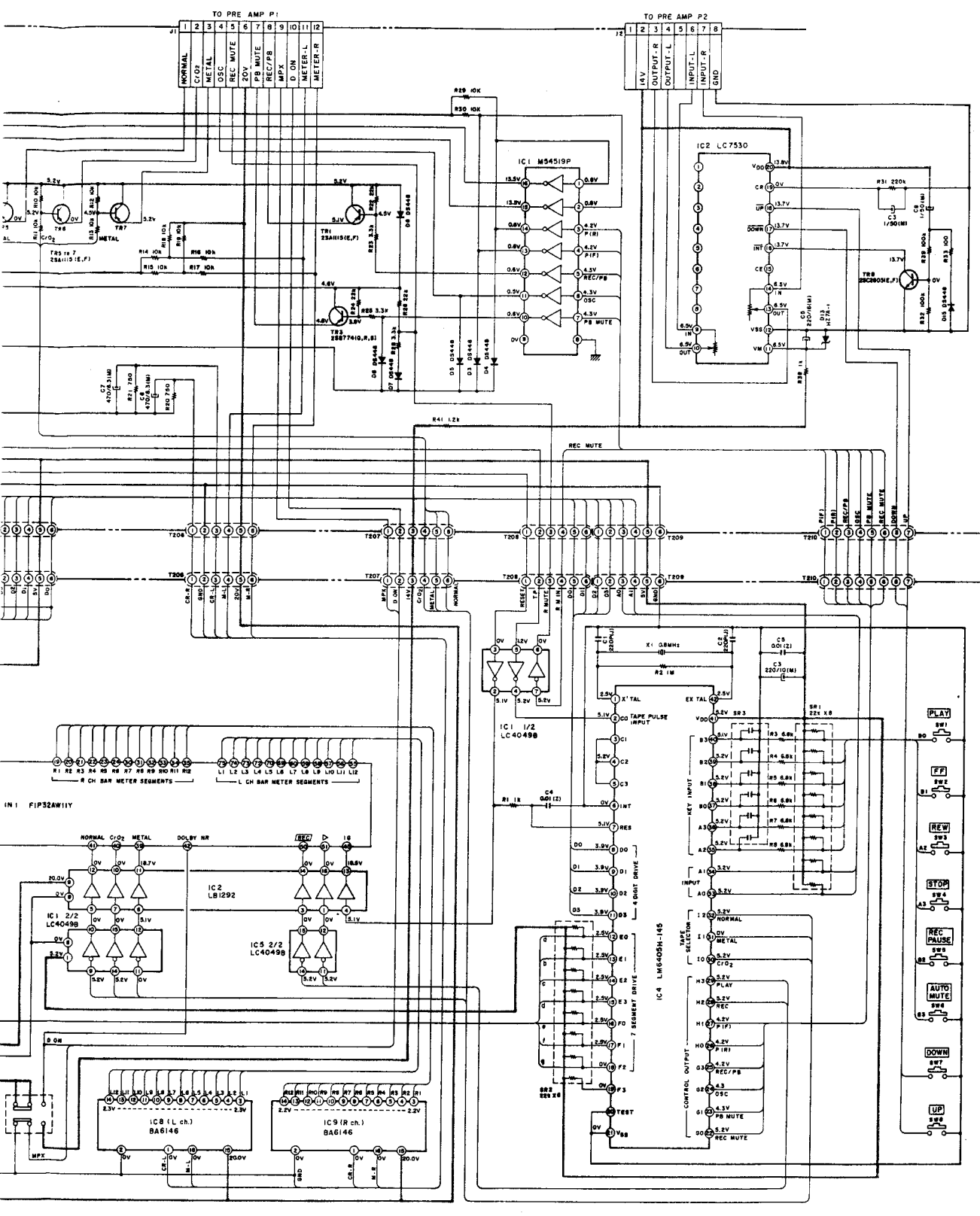

1
2
3
4
5
6
7
8

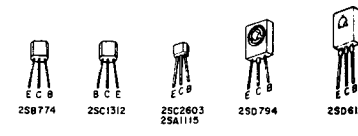

VOLTAGE AT STOP MODE
INDICATES: DOLBY ON
METAL
COUNTER 0000
— (POWER SUPPLY) LINE

NOTES
UNLESS OTHERWISE SPECIFIED
ALL RESISTORS IN OHMS 1/4W(J)
ALL CAPACITORS IN μ F 50 WV(J)
(FS) - FAIL SAFE RESISTORS
POWER TRANSFORMER IS DIFFERENT
ACCORDING TO AREA

(CASSETTE DECK)
HX-2
POWER & SYSCON
SCHEMATIC DIAGRAM
No.2-1 830707A

HX-2

JACK PCB
T2043A501B (1/2)

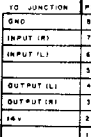
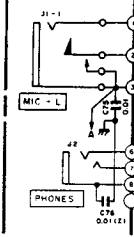

PB/REC HEAD
H901-1
H942497

LEFT

PB/REC HEAD
H901-2

RIGHT

JACK PCB
T2043A501B (2/2)

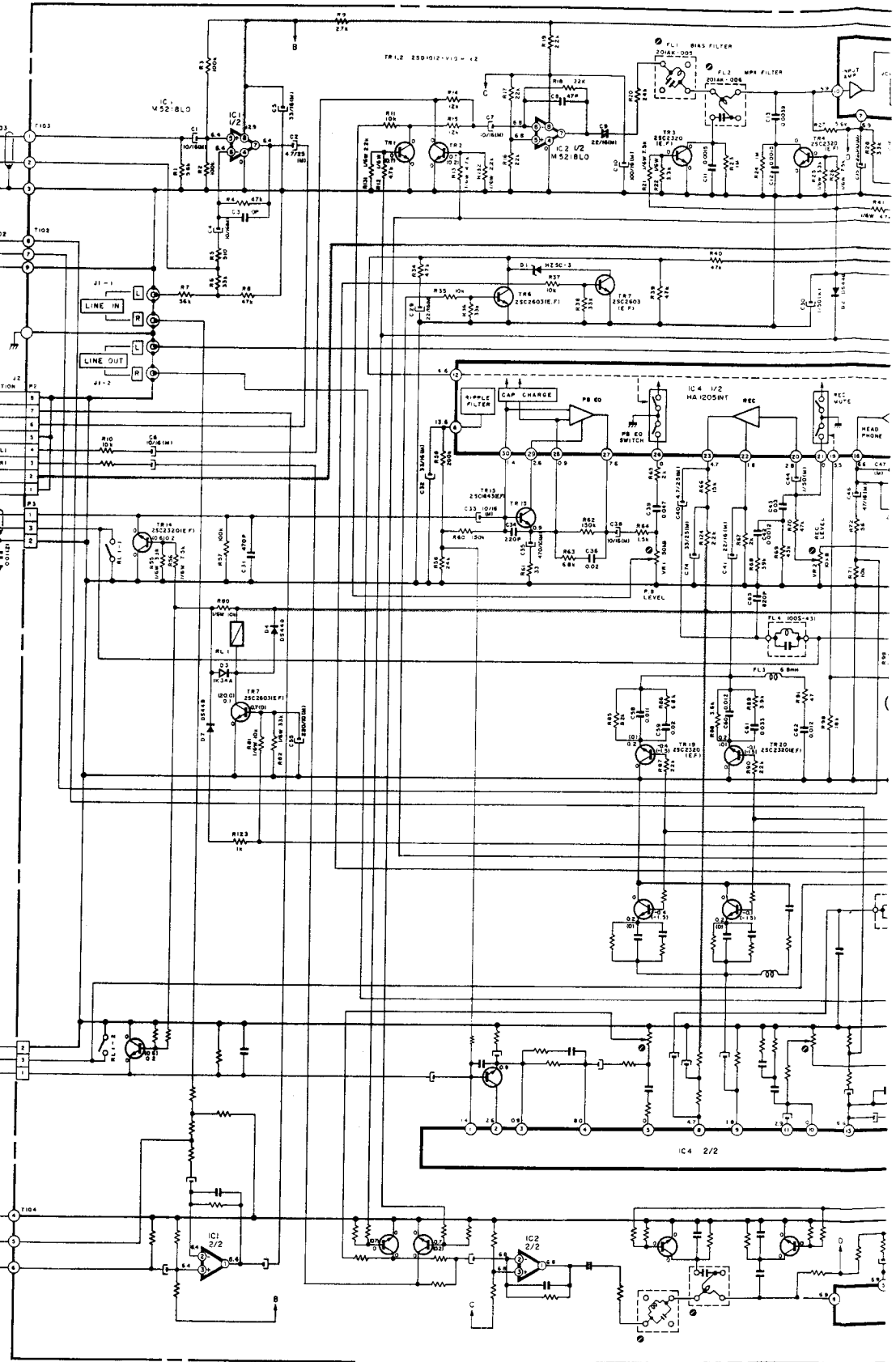
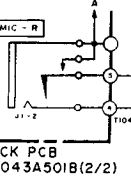

A B C D E F

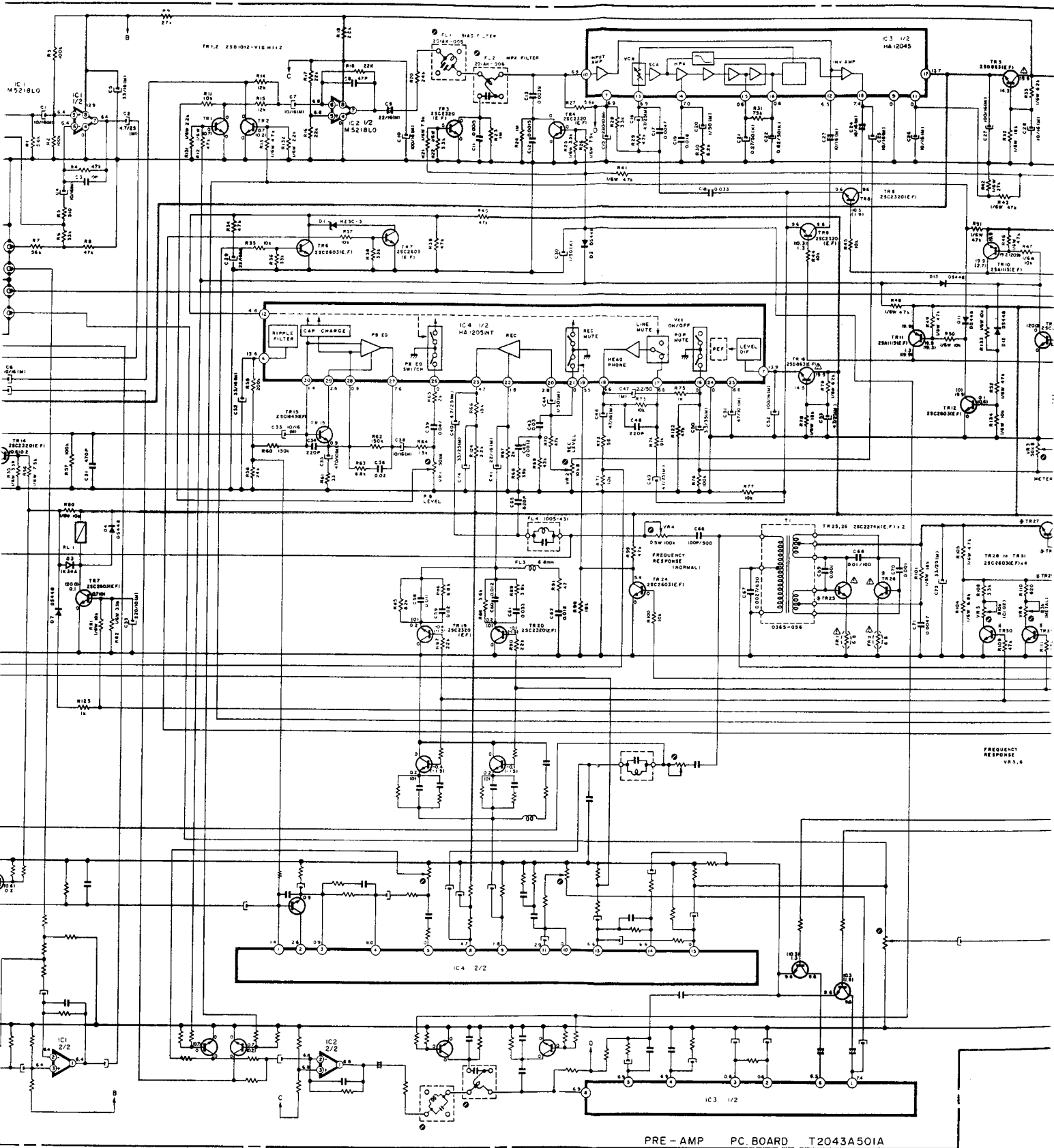

PRE - AMP PC BOARD T2043A501A

WARNING: Δ INDICATES SAFETY CRITICAL PARTS. REPLACE SAFETY CRITICAL PARTS WITH RECOMMENDED PARTS.
AVERTISSEMENT: Δ R. INDIQUE LES PIÈCES CRITIQUES. NE REMPLACEZ QUE DES PIÈCES RECOMMANDÉES.

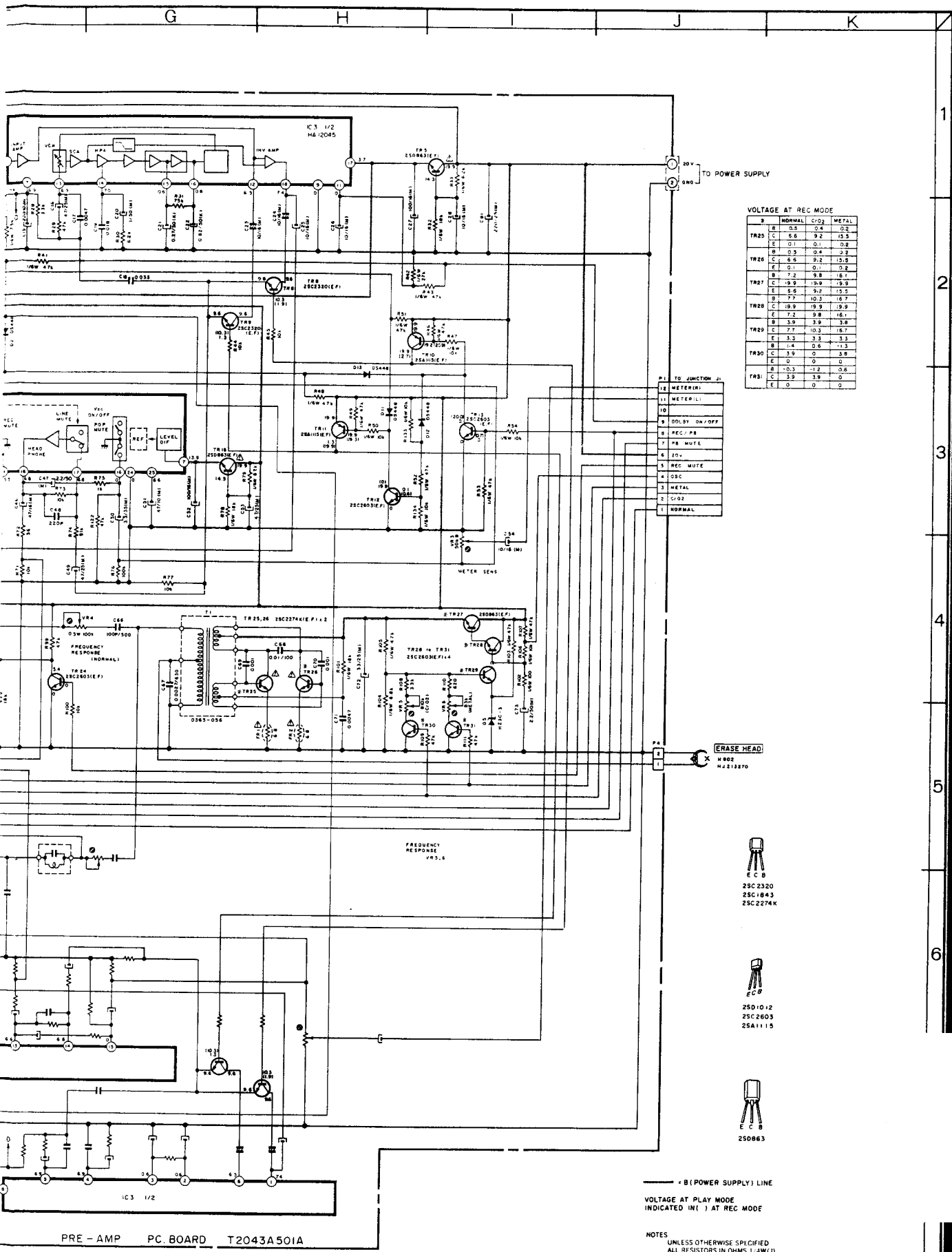

HX-2 AMP
SCHEMATIC DIAGRAM
NO.2-2 830708A

WARNING: INDICATES SAFETY CRITICAL COMPONENTS FOR CONTINUOUS SAFETY.
REPLACE SAFETY CRITICAL COMPONENTS ONLY WITH MANUFACTURER'S
RECOMMENDED PARTS.
AVERTISSEMENT: SUIVRE LES COMPOSANTS CRITIQUES DE SECURITE
POUR MAINTENIR LE DEGRE DE SECURITE DE L'APPAREIL.
NE REMPLACER QUE DES PIECES RECOMMANDEES PAR LE FABRICANT.

RESISTOR SYMBOLS:
C C 9
25C2320
25C1843
25C2274X

RESISTOR SYMBOLS:
C C 9
25D1012
25C2603
25A1115

RESISTOR SYMBOLS:
C C 9
250863

(B) (POWER SUPPLY) LINE

VOLTAGE AT PLAY MODE INDICATED IN () AT REC MODE

NOTES
UNLESS OTHERWISE SPECIFIED
ALL RESISTORS IN OHMS (Ω), 1/4W (1/4)
ALL CAPACITORS IN P.F. 50 WV (50)
(FS) FAIL SAFE RESISTORS

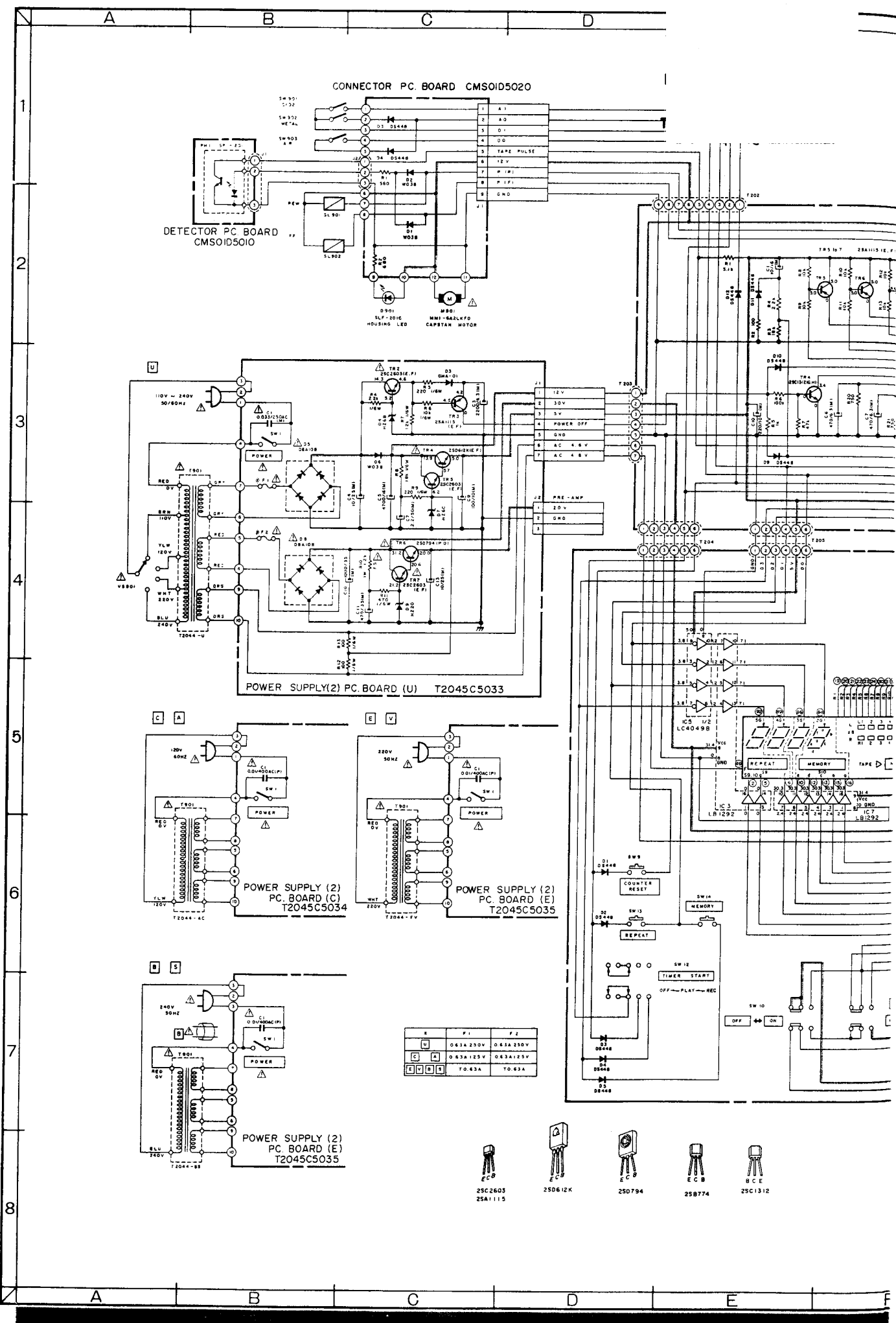

CONNECTOR PC BOARD CMSOID5020

DETECTOR PC BOARD CMSOID5010

POWER SUPPLY(2) PC BOARD (U) T2045C5033

POWER SUPPLY (2) PC BOARD (C) T2045C5034

POWER SUPPLY (2) PC BOARD (E) T2045C5035

POWER SUPPLY (2) PC BOARD (S) T2045C5035

	F1	F2
U	0.63A 250V	0.63A 250V
C	0.63A 125V	0.63A 125V
E	T.O. 63A	T.O. 63A

- 
 25C2603
25A115
- 
 250612K
- 
 250794
- 
 25B774
- 
 25C1312

CONNECTOR PC. BOARD CMS01D5020

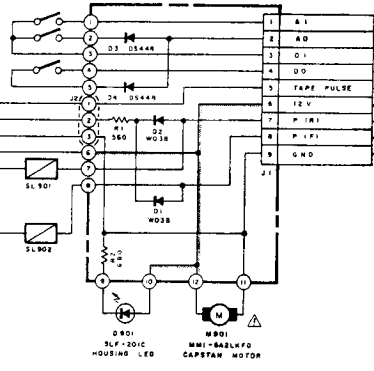

JUNCTION PC BOARD T2044A502B

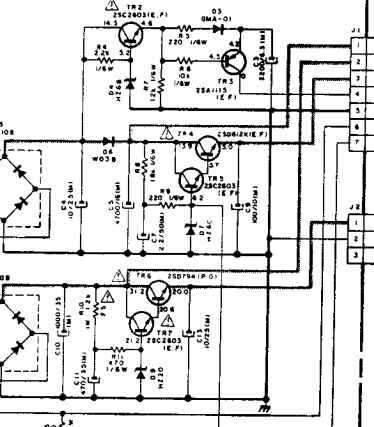
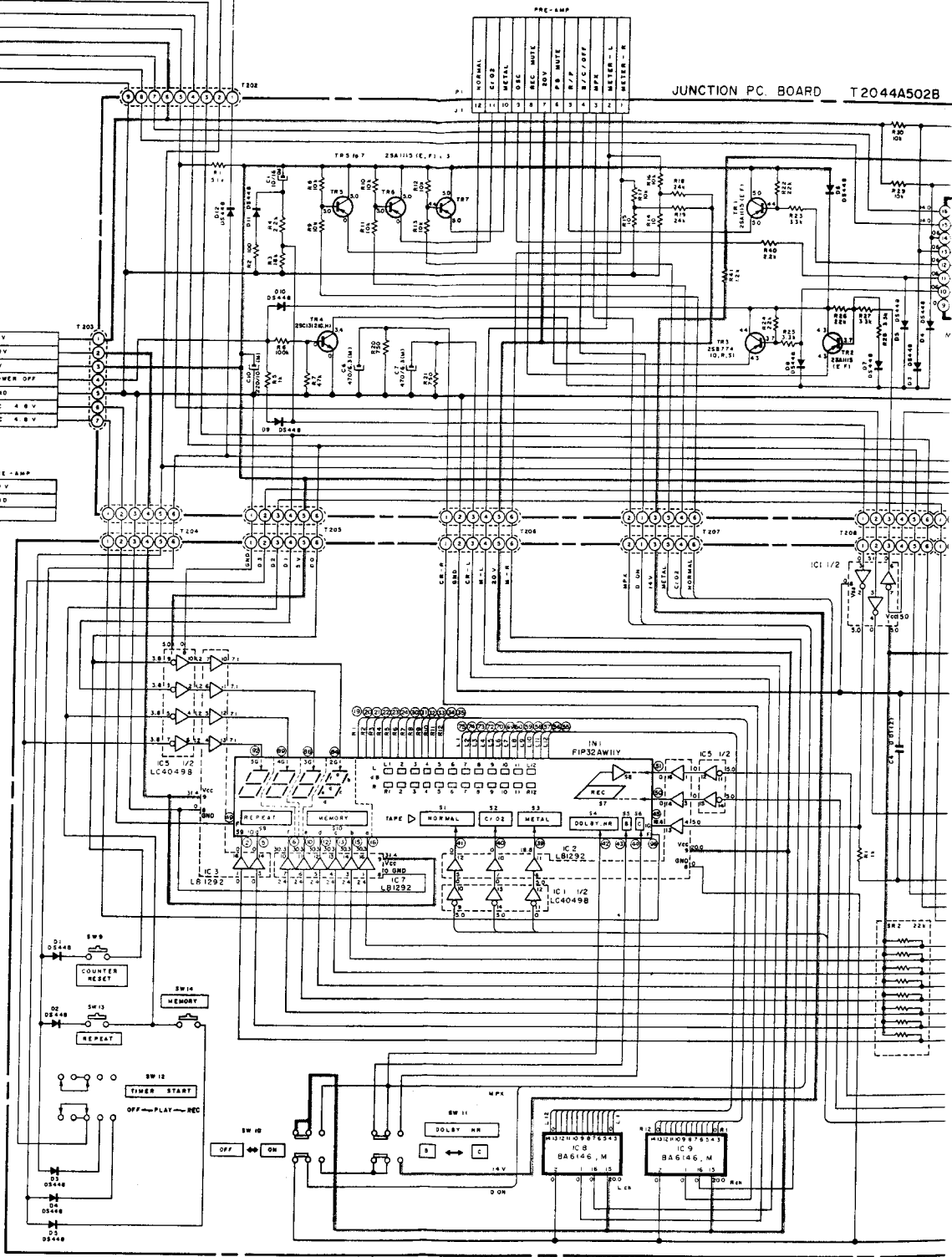

SUPPLY (2) PC BOARD (U) T2045C5033

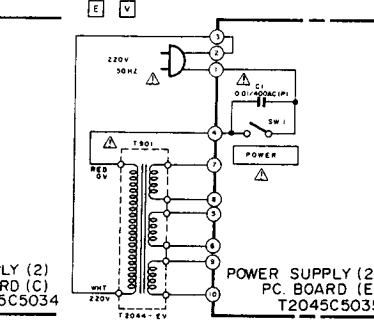

POWER SUPPLY (2) PC BOARD (E) T2045C5035

R	F1	F2
0.63A 250V	0.63A 250V	0.63A 250V
0.63A 25V	0.63A 25V	0.63A 25V
T0.63A	T0.63A	T0.63A

SUPPLY (2) BOARD (C) T2045C5034

- 25C2603 25A1115
- 250612K
- 250794
- 25B774
- 25C1312

WARNING: Δ INDICATES SAFETY CRITICAL COMPONENTS FOR CONTINUED SAFETY. REPLACE SAFETY CRITICAL COMPONENTS ONLY WITH MANUFACTURER'S RECOMMENDED PARTS.
 AVERTISSEMENT: Δ IL INDIQUE LES COMPOSANTS CRITIQUES DE SECURITE. POUR MAINTENIR LE DEGRE DE SECURITE DE L'APPAREIL, NE REMPLACEZ QUE DES PIECES RECOMMANDEES PAR LE FABRICANT.

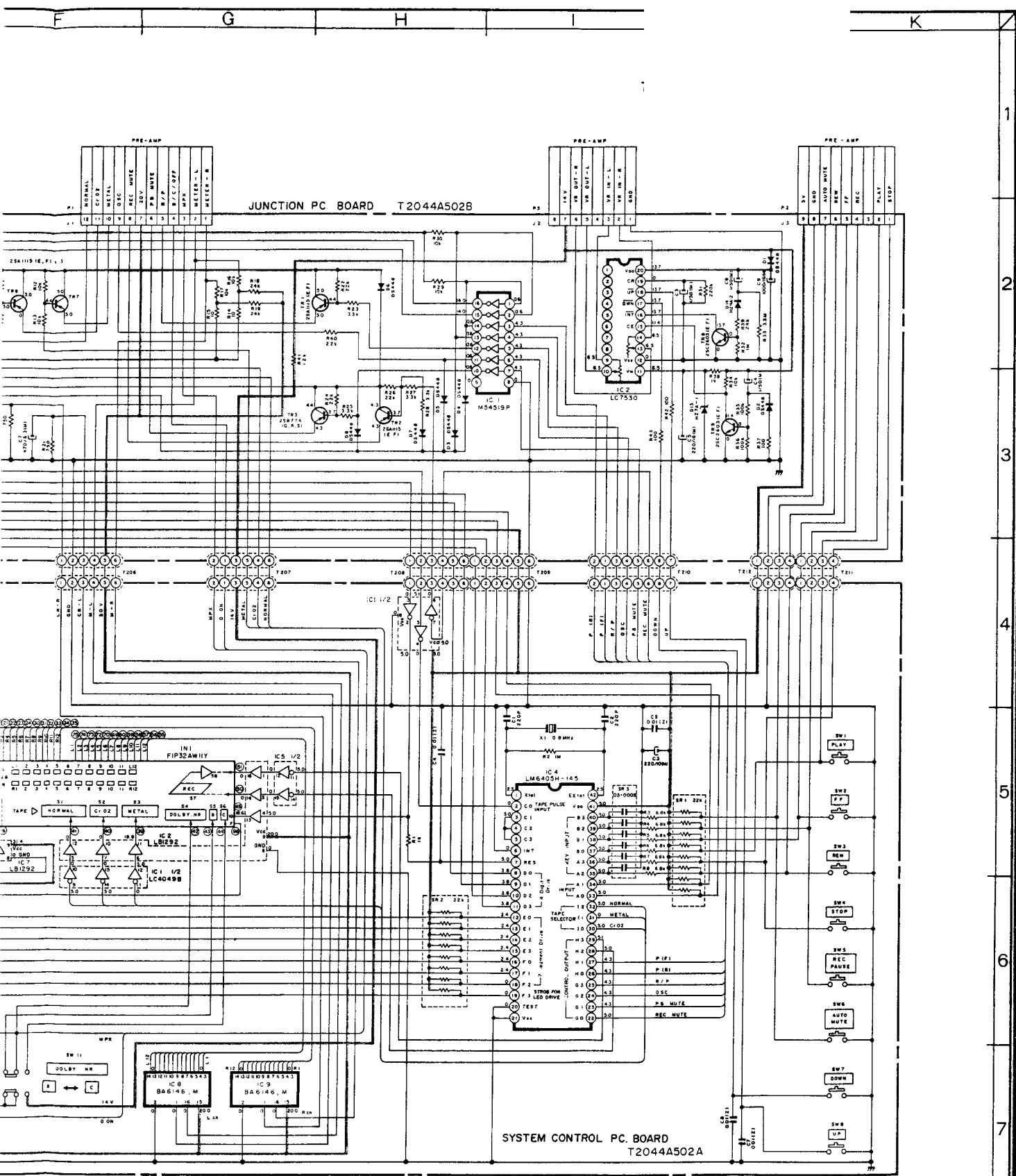

—•— (POWER SUPPLY) LINE

WARNING: INDICATES SAFETY CRITICAL COMPONENTS FOR CONTINUED SAFETY. REPLACE SAFETY CRITICAL COMPONENTS ONLY WITH MANUFACTURER'S RECOMMENDED PARTS.

AVERTISSEMENT: AIN INDIQUE LES COMPOSANTS CRITIQUES DE SECURITE. POUR MAINTENIR LE DEGRE DE SECURITE DE L'APPAREIL, NE REMPLACER QUE DES PIECES RECOMMANDEES PAR LE FABRICANT.

VOLTAGES AT STOP MODE

NOTE: UNLESS OTHERWISE SPECIFIED ALL RESISTORS IN OHMS (1/4W/1%) ALL CAPACITORS IN UF (50 WV/1%) IFS: - ALL SAFE RESISTORS

POWER TRANSFORMER IS DIFFERENT ACCORDING TO AREA

(CASSETTE DECK)
 HX-3
 POWER & SYSCON
 SCHEMATIC DIAGRAM
 No.2-1 830709A

1
2
3
4
5
6
7
8

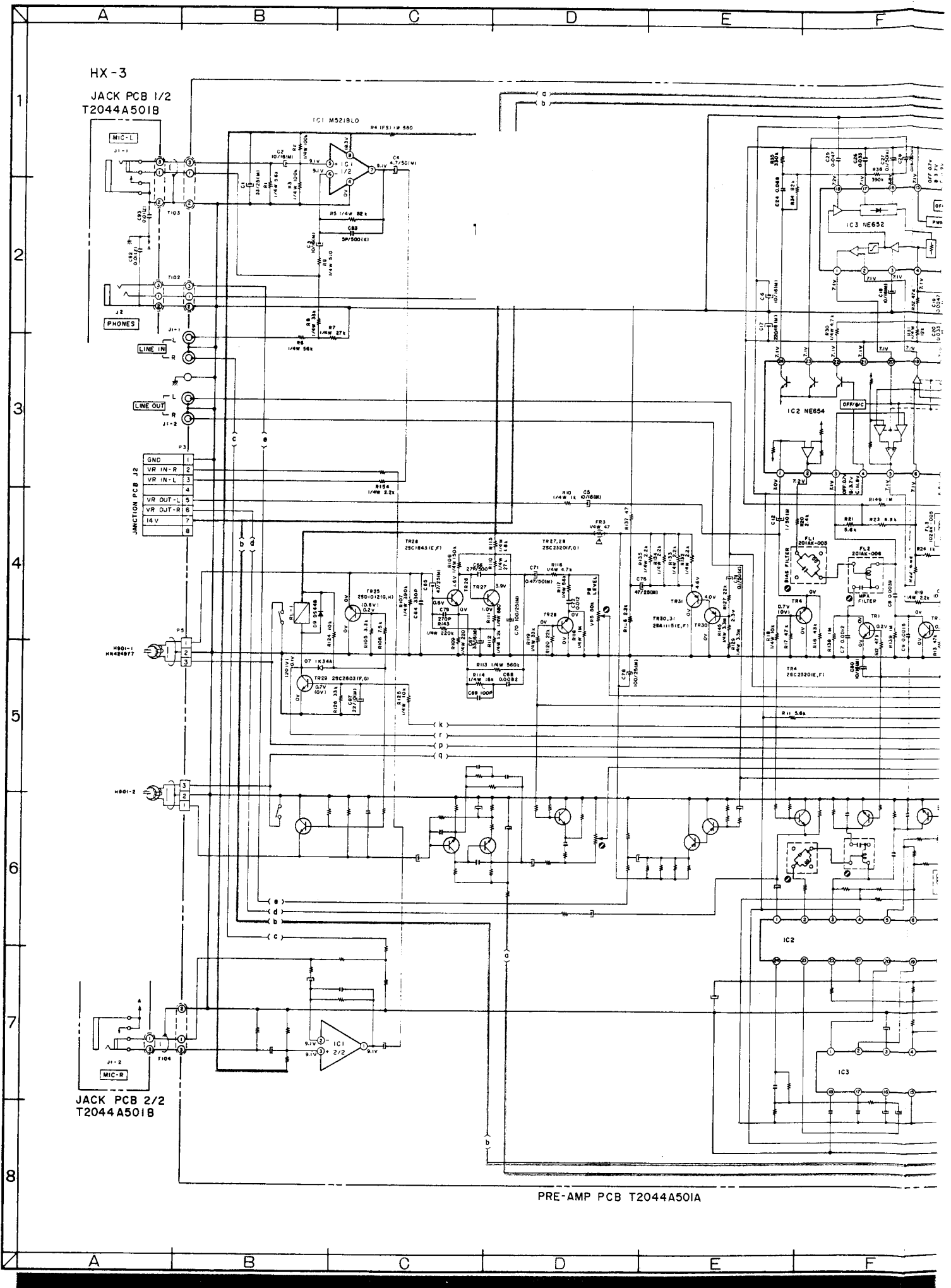

HX-3
 JACK PCB 1/2
 T2044A501B

JACK PCB 2/2
 T2044A501B

PRE-AMP PCB T2044A501A

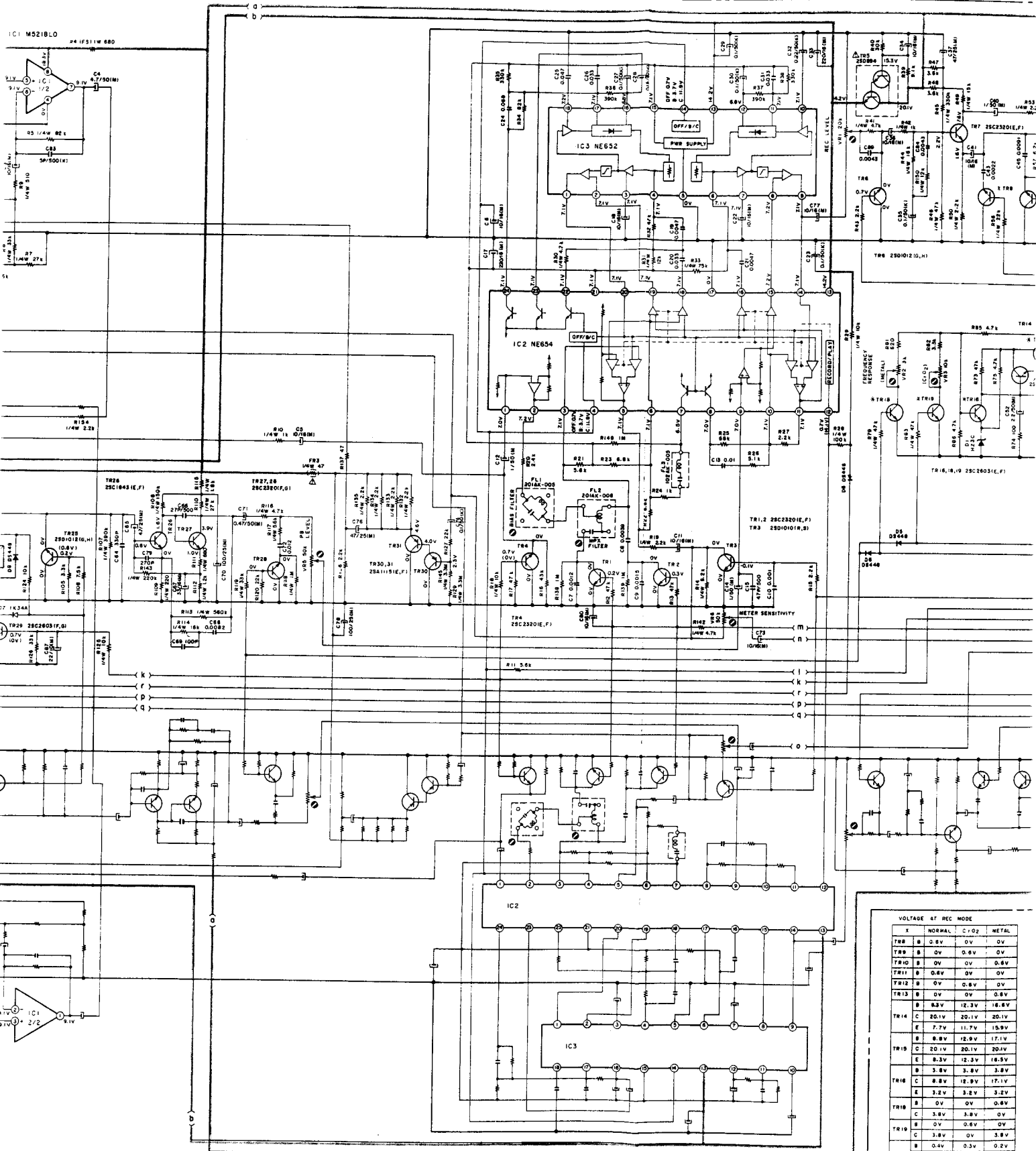

PRE-AMP PCB T2044A501A

VOLTAGE AT REC MODE			
X	NORMAL	C-02	METAL
TR8	B 0.6V	0V	0V
TR10	B 0V	0.6V	0V
TR11	B 0.6V	0V	0.6V
TR12	B 0V	0.6V	0V
TR13	B 0V	0V	0.6V
TR14	B	8.3V	12.3V 16.6V
	C	20.1V	20.1V 20.1V
	E	7.7V	11.7V 15.9V
TR15	B	8.8V	12.9V 17.1V
	C	20.1V	20.1V 20.1V
	E	8.3V	12.3V 16.5V
TR16	B	3.8V	3.8V 3.8V
	C	8.8V	12.8V 17.1V
	E	3.2V	3.2V 3.2V
TR18	B	0V	0.6V
	C	3.8V	3.8V 0V
	B	0V	0.6V
TR19	C	3.8V	3.8V
	B	0.4V	0.3V 0.2V
	C	7.8V	11.7V 15.9V
TR20	B	0.1V	0.1V 0.1V
	C	0.4V	0.3V 0.2V
	E	7.6V	11.7V 15.9V
TR21	B	0.1V	0.1V 0.2V

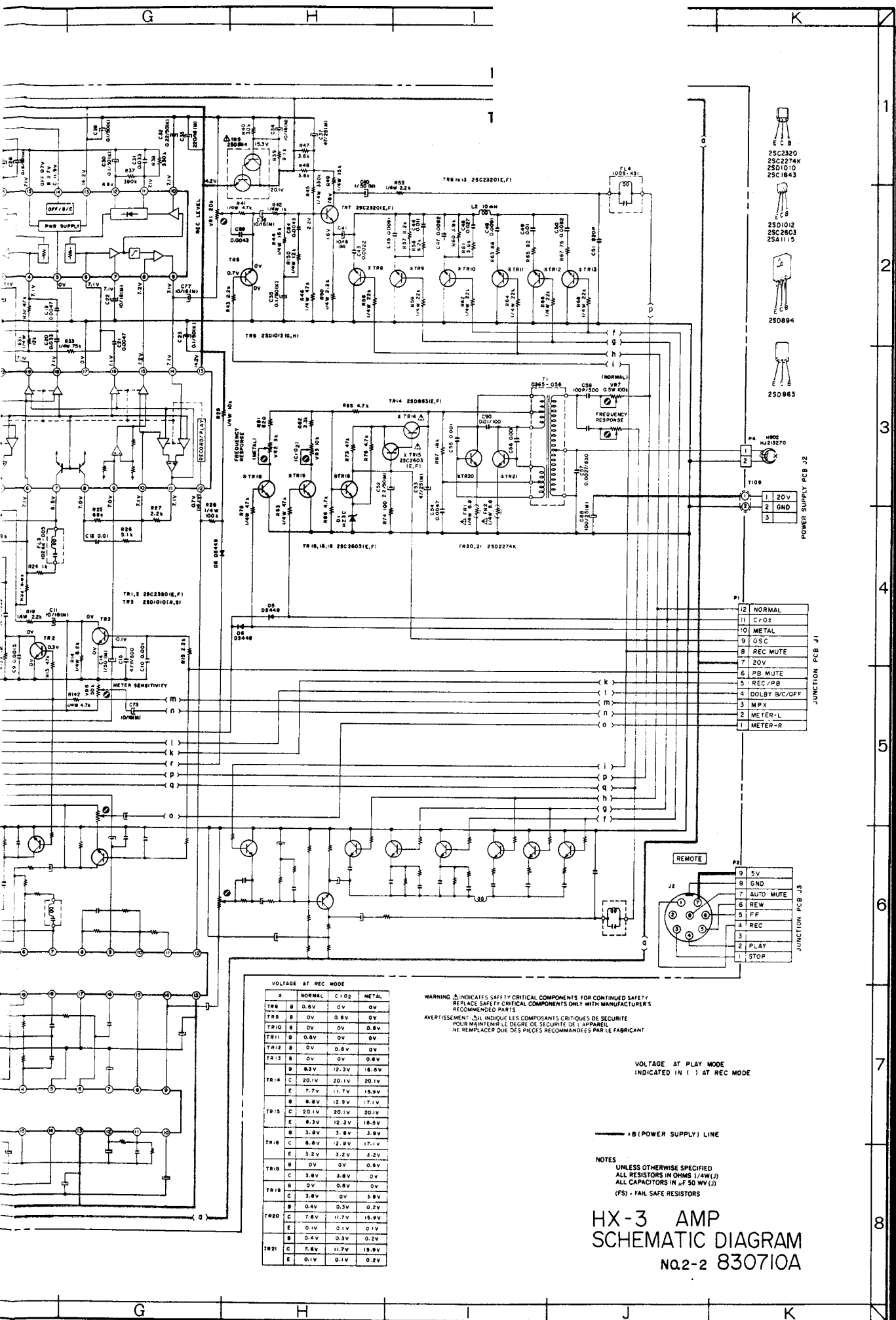

VOLTAGE AT REC MODE			
X	NORMAL	C/O2	METAL
TR6	B 0.6V	0V	0V
TR9	B 0V	0.6V	0V
TR10	B 0V	0V	0.6V
TR11	B 0.6V	0V	0V
TR12	B 0V	0.6V	0V
TR13	B 0V	0V	0.6V
TR14	B 8.3V	12.3V	16.6V
TR15	E 7.7V	11.7V	15.9V
TR15	B 8.8V	12.9V	17.1V
TR15	C 20.1V	20.1V	20.1V
TR16	E 8.3V	12.3V	16.6V
TR16	B 3.8V	3.8V	3.8V
TR16	C 8.8V	12.8V	17.1V
TR18	E 3.2V	3.2V	3.2V
TR18	B 0V	0V	0.6V
TR18	C 3.8V	3.8V	0V
TR19	B 0V	0.6V	0V
TR19	C 3.8V	0V	3.8V
TR20	B 0.4V	0.3V	0.2V
TR20	C 7.8V	11.7V	15.9V
TR21	B 0.4V	0.3V	0.2V
TR21	C 7.8V	11.7V	15.9V
TR21	E 0.1V	0.1V	0.2V

WARNING: INDICATES SAFETY CRITICAL COMPONENTS FOR CONTINUED SAFETY. REPLACE SAFETY CRITICAL COMPONENTS ONLY WITH MANUFACTURER'S RECOMMENDED PARTS.

AVERTISSEMENT: IL INDIQUE LES COMPOSANTS CRITIQUES DE SECURITE POUR MAINTENIR LE DEGRE DE SECURITE DE L'APPAREIL. NE REMPLACEZ QUE LES PIECES RECOMMANDEES PAR LE FABRICANT.

VOLTAGE AT PLAY MODE
INDICATED IN () AT REC MODE

NOTES
UNLESS OTHERWISE SPECIFIED
ALL RESISTORS IN OHMS 1/4W(J)
ALL CAPACITORS IN μF 50 WV(J)
(FS) - FAIL SAFE RESISTORS

HX-3 AMP SCHEMATIC DIAGRAM No.2-2 830710A

- 25C2320
- 25C2274K
- 25D1010
- 25C1843
- 25D1012
- 25C2803
- 25A1115
- 25D894
- 25D863

POWER SUPPLY PCB J2

- JUNCTION PCB J1
- 12 NORMAL
 - 11 C/O2
 - 10 METAL
 - 9 OSC
 - 8 REC MUTE
 - 7 20V
 - 6 PB MUTE
 - 5 REC/PB
 - 4 DOLBY B/C/OFF
 - 3 MPX
 - 2 METER-L
 - 1 METER-R

- JUNCTION PCB J3
- 9 5V
 - 8 GND
 - 7 AUTO MUTE
 - 6 REV
 - 5 FF
 - 4 REC
 - 3 PLAY
 - 2 STOP