



RADIO SERVICE BULLETIN

Model 5000

5 Tube Mantel Model

A.C. Universal Superheterodyne Radio Receiver

SERVICE INFORMATION

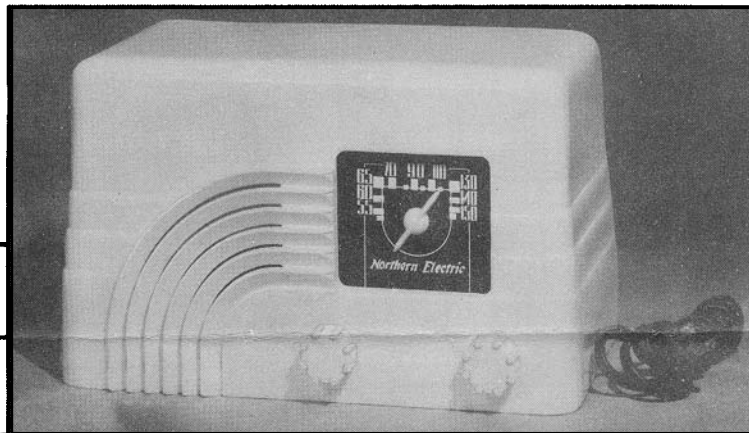

SPECIFICATIONS

GENERAL: This specification covers the Radio Receiver Model 5000. Model 5000 is an a-c Universal Superheterodyne Radio Receiver.

1. **FREQUENCY RANGE:**
540 KC to 1570 KC (Standard Broadcast)
2. **INTERMEDIATE FREQUENCY:**
455 KC
3. **TUBES:**

Type	Function
12SA7	Converter
12SK7	I-F Amplifier
12SQ7	(2nd Detector, (A.V.C. and 1st Audio Amplifier)
35Z5GT	Rectifier
35L6GT	Output
4. **POWER SUPPLY:**
110-125 volts, 25-60 cycles
110-125 volts d-c (Reverse plug if set does not operate.)
Consumption 30 watts
5. **POWER OUTPUT:**
1.5 watts
6. **A.V.C.:**
Applied to 12SK7 I-F and 12SA7 converter
7. **AUDIO SYSTEM:**
Audio portion of 12SQ7 resistance-capacitance coupled to 35L6GT power output.
8. **ANTENNA:**
Built in Loop with terminal for use with external antenna.
9. **CONTROLS, TWO:**
(1) Left-hand knob, volume control and on-off switch.
(2) Right-hand knob, tuning control.
10. **LOUDSPEAKER:**
5" P.M.
11. **DIMENSIONS:**
Chassis assembly (excluding shafts) 10 $\frac{1}{2}$ " x 5 $\frac{3}{8}$ " x 5 $\frac{1}{8}$ ".
Overall cabinet space (including knobs) 10 $\frac{5}{8}$ " x 6 $\frac{1}{4}$ " x 6 $\frac{3}{16}$ ".

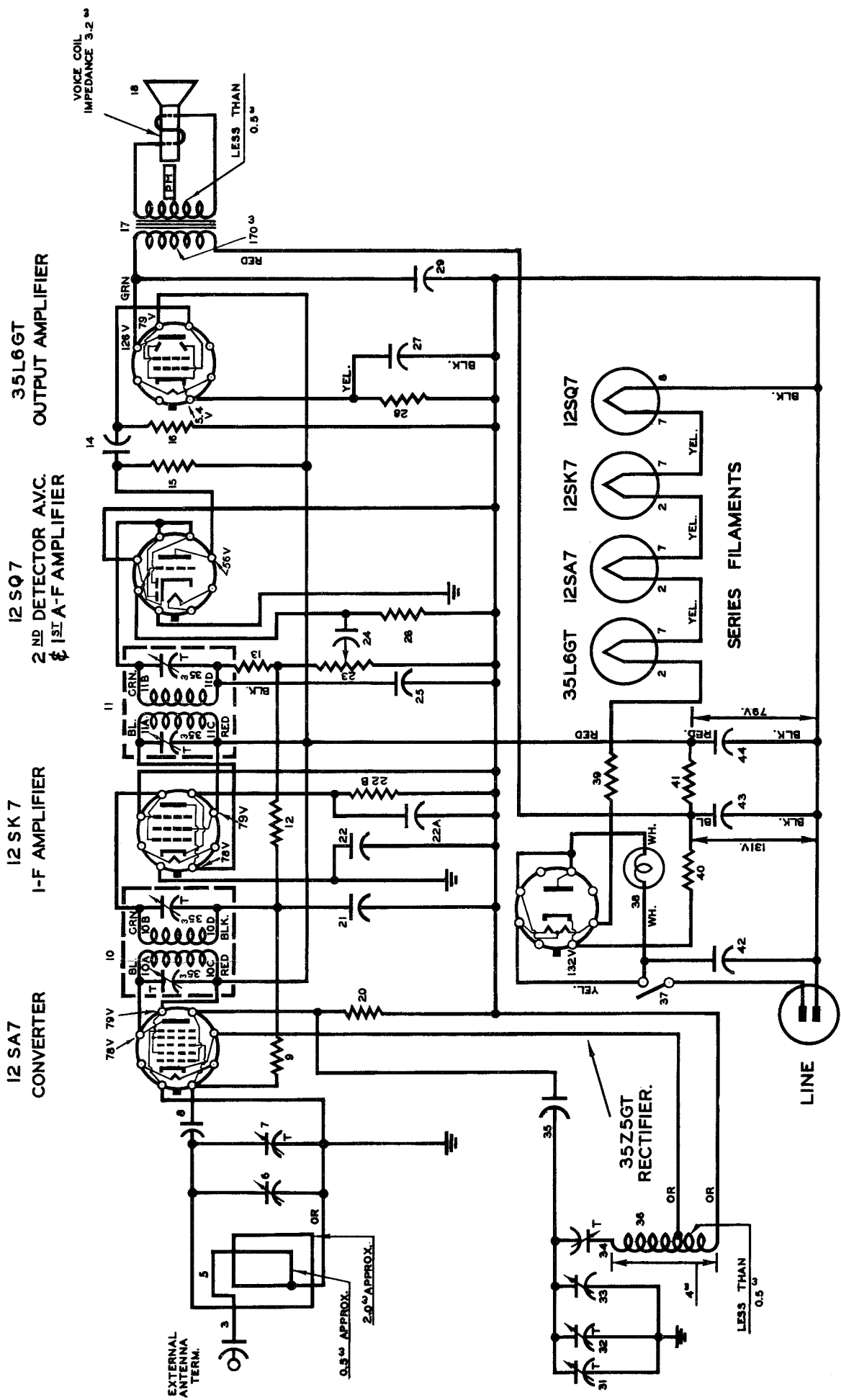

- NOTES
- 1- ALL VOLTAGES ARE READ FROM COMMON NEGATIVE LEAD USING A 20 000 ω /V METER.
 - 2- LINE VOLTAGE IS 117 VOLTS DURING VOLTAGE MEASUREMENTS.
 - 3- WIRING SIDE OF TUBES SHOWN.

Schematic Diagram Model 5000

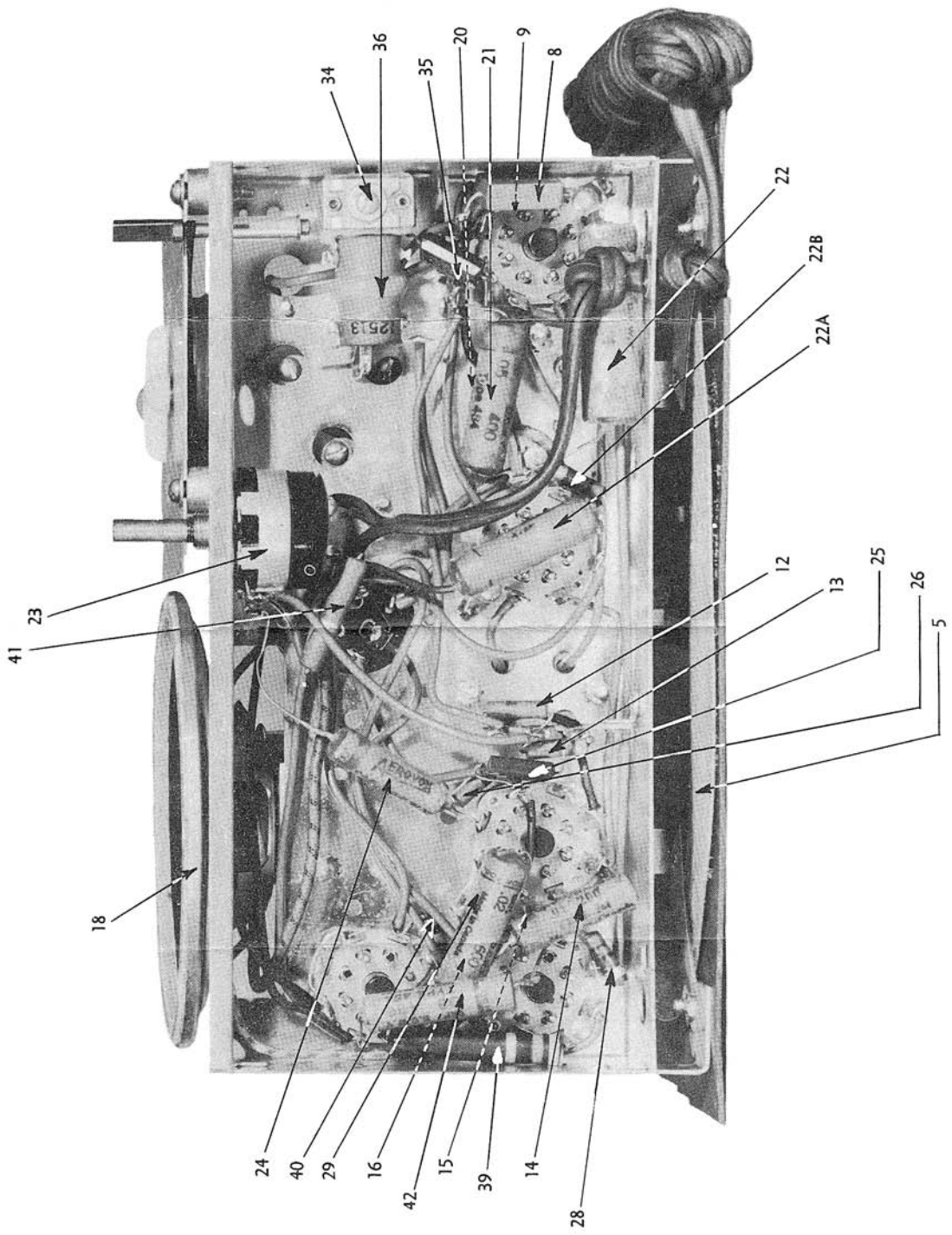

Wiring Diagram Model 5000

REALIGNING DETAILS

I.F. Alignment

Connect the generator ground lead to the common negative return circuit in receiver. It remains in this position throughout test. Set the generator to 455 kilocycles. Connect generator high side through a 0.1 mfd. condenser to the 1st detector grid (pin #8 on 12SA7) and adjust items 10A, 10B, 11A, and 11B (on I.F. cans) for maximum output. Gang condenser should be open during I.F. alignment.

R.F. Alignment

Connect the generator ground lead to the common negative return. Use a 100 mmfd. capacitor in series with

the high side of the signal generator and connect to the antenna terminal.

Set the signal generator and dial pointer to 1400 kilocycles and adjust the oscillator trimmer, items 31 and 32 (in front section of gang) for maximum output.

Adjust the antenna trimmer, item 7, (located at rear of gang) for maximum output, rocking gang while doing so. Set the generator to 600 kilocycles and tune in the signal. Adjust oscillator lag, item 34, (located on fixed end of oscillator coil, under chassis) for maximum output. Recheck at 1400 kilocycles.

REPLACEMENT PARTS LIST

Item	Description	Tolerance + - %	Part No.	Item	Description	Tolerance + - %	Part No.
3	Capacitor, Paper: .003 mfd. 600 volts	25	K5660-3	27	Capacitor (part of R12730): 20 mfd, 25 volts	+ No Max.-10	R12730
5	Loop Antenna Assembly		R8142-23	28	Resistor: 220 ohms, 1/2 watt	10	K5975-12B
6	Capacitor, Gang Tuning(Part of R12734): 420-420 mmfd.	1	R12734	29	Capacitor: .02 mfd, 200 volts	+20 -10	K2227-7
7	Capacitor, Trimmer (Part of R12734): 1.5-20 mmfd.		R12734	31	Capacitor trimmer (Part of R12734): 1.5-20 mmfd.		
8	Capacitor, Mica: 1000 mmfd. 800 volts	10	K1611-23	32	Capacitor, trimmer (Part of R12734): 1.5-20 mmfd.	1	
9	Resistor: 1 meg. 1/2 watt	20	K5974-25C	33	Capacitor, gang tuning (Part of R12734): 420 mmfd.		R12734
10	Transformer, 1st I.F.		R15306	34	Capacitor trimmer - Part of R13472 Trimmer and Bracket Assembly, 300-625 mmfd.		K3860-8
10A & B & C & D	Capacitor, Trimmer, 1st I.F.: 20-150 mmfd.		R15373	35	Capacitor, Mica: 50 mmfd., 800 volts	10	K1611-1T R12513
11	Transformer, 2nd I.F.		R15307-1	36	Coil, Oscillator B.C.		K4991-2
11A & B & C & D	Capacitor, Trimmer, 2nd I.F.: 20-150 mmfd.		R15373	37	Switch, ON-OFF (Part of K4991-2)		K2589-3
12	Resistor: 2.2 meg. 1/2 watt	20	K5974-17C	38	Lamp, Dial: 6.3 volts, 250 ma.	10	K5985-22B
13	Resistor: 47,000 ohm, 1/2 watt	20	K5974-57C	39	Resistor: 82 ohms, 2 watt	20	K5975-32C
14	Capacitor, paper: .01 mfd., 200 volt	+20 -10	K2227-6	40	Resistor: 33 ohms, 1/2 watt	10	K5976-87B
15	Resistor: .22 meg., 1/2 watt	20	K5974-41C	41	Resistor: 2700 ohms, 1 watt	10	K2228-18
16	Resistor: .47 meg., 1/2 watt	20	K5974-33C	42	Capacitor, paper: .03 mfd, 400 volts	+ No Max.-10	R12730
17	Transformer, Output		K3873-9	43	Capacitor, (Part of R12730): 40 mfd., 150 volts	+ No Max.-10	R12730
18	Loudspeaker		R12791	44	Capacitor, (Part of R12730): 40 mfd., 150 volts	+ No Max.-10	R12730
20	Resistor: 22,000 ohm, 1/2 watt	20	K5974-65C		Sockets		R15327
21	Capacitor, paper: .05 mfd., 200 volts	+20 -10	K2227-8		Scale, Dial		R8142-24
22	Capacitor, paper: .2 mfd., 200 volts	10	K2227-22		Indicator, Dial		R13012
22A	Capacitor, paper: .05 mfd., 200 volts	+20 -10	K2227-8		Spring, Dial		R12741
22B	Resistor: 270 ohms, 1/2 watt	10	K5975-10B		Cord, Dial, 10"		K4636
23	Volume-Control (with SW): .5 meg.		K4991-2		Cover, (Celluloid) Dial		R12951
24	Capacitor, paper: .01 mfd., 200 volts	+20 -10	K2227-6		Shaft, Dial Drive		R12727
25	Capacitor, mica: 400 mmfd., 800 volts	10	K1611-24		Socket, Lamp		K5517
26	Resistor: 10 meg. ohms, 1/2 watt	20	K5974-1C		Standoff (3-Term.)		K2114-2
					Standoff (3-Term.)		K2114-1
					Knob (Ivory)		R15348-1
					Knob (Brown Mottle)		R15348-4
					Speed-nut (Bezel mtg.)		R12979
					Cabinet (plastic) Ivory		R13357A
					Cabinet (plastic) Brown Mottle		R12829A
					Trimmer and Bracket Assembly		R13472
					Insulating Mounting Plate (Electrolytic)		R15102

Northern Electric

COMPANY LIMITED

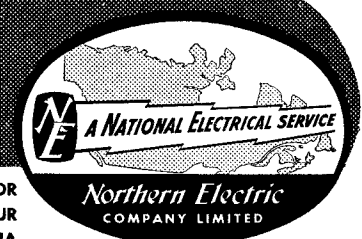

HALIFAX SAINT JOHN, N.B. QUEBEC TROIS RIVIERES SHERBROOKE MONTREAL OTTAWA VAL D'OR
 TORONTO HAMILTON LONDON WINDSOR KIRKLAND LAKE TIMMINS SUBURRY PORT ARTHUR
 WINNIPEG REGINA CALGARY EDMONTON VERNON VANCOUVER VICTORIA



RADIO SERVICE BULLETIN

Model 5000

5 Tube Mantel Model

A.C. Universal Superheterodyne Radio Receiver

AMENDMENT SHEET

The following modifications have been incorporated in the Model 5000 Radio Receiver, these changes becoming effective as per serial numbers shown below.

Serial Number

Modification

8105 On

A .22 megohm half watt resistor added between the chassis and common return lead. This resistor is placed between ground lug and pin 8 on tube type 12SQ7.

17693 On

Design of I.F. Transformers changed, new part numbers being:

1st I. F. Transformer—R15375-1

2nd I. F. Transformer—R15307-2

RS 100A

May 1946.