

"TRADER" SERVICE SHEET
1357

ROBERTS RT.1

Transistorized Battery Portable with Printed Circuit

SIX Mullard P-N-P transistors, a germanium diode detector, a printed circuit and a ferrite rod internal aerial are employed in the Roberts RT.1 2-band portable receiver designed to operate from a single 6V battery. The tuning range is 185-571m and 1,100-2,200m.

Release date and original price: April, 1958, £17 8s 9d including battery. Purchase tax extra.

CIRCUIT DESCRIPTION

M.W. and L.W. aerial coils L1, L2 and coupling coils L3, L4 are mounted on a ferrite rod and form the internal aerial. M.W. coils L1, L3 are tuned by C1, C2 and L.W. coils L2, L4 by C2, C3, C4. C2 forms one section of the tuning gang and C1, C3, C4 are parallel trimmer capacitors. R.F. signal developed across the aerial coupling circuit is applied via low impedance coupling coils L3, L4 to the base of TR1, which operates as frequency changer. Base bias is provided by the H.T. potential divider R1, R2 in conjunction with the emitter resistor R3.

Local oscillator circuit is formed by L5, L6, L7, with tuning by C7, C8 (M.W.) and by C7, C9, C10 (L.W.). C7 is one section of the tuning gang and C8, C9, C10 are parallel trimmer capacitors. Tracking is by the adjustable inductances of L5, L6, L7. Reaction coupling from TR1 collector via L5.

TR2 and TR3 operate as a two-stage earthed-emitter I.F. amplifier with transformer couplings L8, L9; L10, L11; L12, L13. Neutralizing by C15, R7, C19. Base bias is provided by H.T. potential dividers R4, R5, R11 and R8, R9, operating in conjunction with emitter resistors R6, R10.

Intermediate frequency 470kc/s

Germanium diode X1 is employed as signal detector, and the audio frequency component in its rectified output is developed across the combined load resistor and volume control R11. I.F. filtering by C22, and additionally by R13, C24 on L.W. A.F. coupling to driver stage TR4 via C23.

The D.C. potential developed from the signal current through R11 is fed back as bias

to TR2, giving automatic gain control. Decoupling by R5, C13. R13, C24 and S8, S9 form a filter to stabilize operation on L.W. only.

Output from TR4 is coupled via driver transformer T1 to TR5 and TR6, which operate in a common-emitter class B push-pull output stage. Base bias for TR5 and TR6 is provided by H.T. potential divider R18, R19 in conjunction with the common emitter resistor R20. Temperature compensation is provided by a thermistor connected in parallel with R19 and situated close to TR5, TR6.

Outputs of TR5 and TR6 are coupled to the speaker via output transformer T2. Tone correction by negative feedback circuit comprising R21, R22, R17, C25. Pre-set resistor R18 is adjusted to correct the H.T. current in the output stage.

CIRCUIT ALIGNMENT

Equipment Required.—An accurately calibrated signal generator; a high resistance voltmeter or an output meter of 3 ohms im-
(Continued overleaf col. 1)

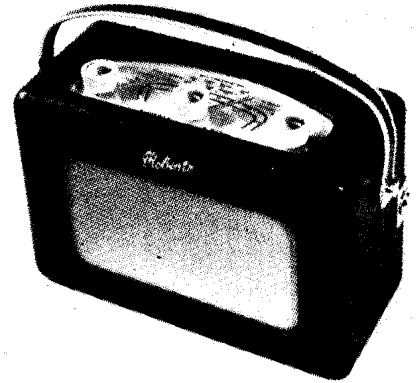

Appearance of the Roberts RT.1. For easy access to the battery, the back of the case is hinged at the left-hand end and fastened at the right-hand end with a clasp which is visible in our photograph.

Resistors

R1	10k Ω	A1
R2	22k Ω	A1
R3	3.9k Ω	A1
R4	43k Ω	B2
R5	8.2k Ω	B1
R6	680 Ω	B1
R7	1.5k Ω	B2
R8	20k Ω	B2
R9	3.9k Ω	B1
R10	470 Ω	F4
R11	5k Ω	H3
R12	1.5k Ω	F3
R13	1.5k Ω	F3
R14	27k Ω	C2
R15	10k Ω	C2
R16	680 Ω	C2
R17	390 Ω	C1
R18	3k Ω	H3
R19	82 Ω	D1
R20	5.6 Ω	D1
R21	820 Ω	D1
R22	10 Ω	C1

Capacitors

C1	—	A1
C2	—	F3
C3	—	A2

C4	—	E3
C5	0.1μF	A1
C6	0.01μF	A1
C7	—	F4
C8	—	A2
C9	—	A2
C10	—	A1
C11	250pF	A2
C12	0.1μF	F3
C13	0.01μF	A1
C14	0.1μF	B1
C15	58pF	B2
C16	250pF	B2
C17	0.1μF	B1
C18	0.1μF	F4
C19	18pF	B2
C20	250pF	B2
C21	100μF	C2
C22	0.02μF	G4
C23	8μF	C2
C24	0.02μF	F3
C25	100μF	C1
C26	0.1μF	D1

Coils*

L1	1.0	B1
L2	4.7	D1
L3	—	B1

L4	—	D1
L5	—	A2
L6	—	A2
L7	1.9	A2
L8 (total)	4.0	A2
L9	—	A2
L10 (total)	4.0	B2
L11	—	B2
L12 (total)	4.0	B2
L13	—	B2
L14	3.0	—

Other Components*

T1	{ a 150.0	} C2
	{ b 43.0	
	{ c 50.0	
T2	{ a, b (total) 7.0	} D2
	{ c —	
	{ —	
X1	Mullard OA70	G4
	Thermistor VA1040	D2
S1-S10	—	E3

*Approximate D.C. resistance in ohms. Read "Warning" under "General Notes" before making measurements

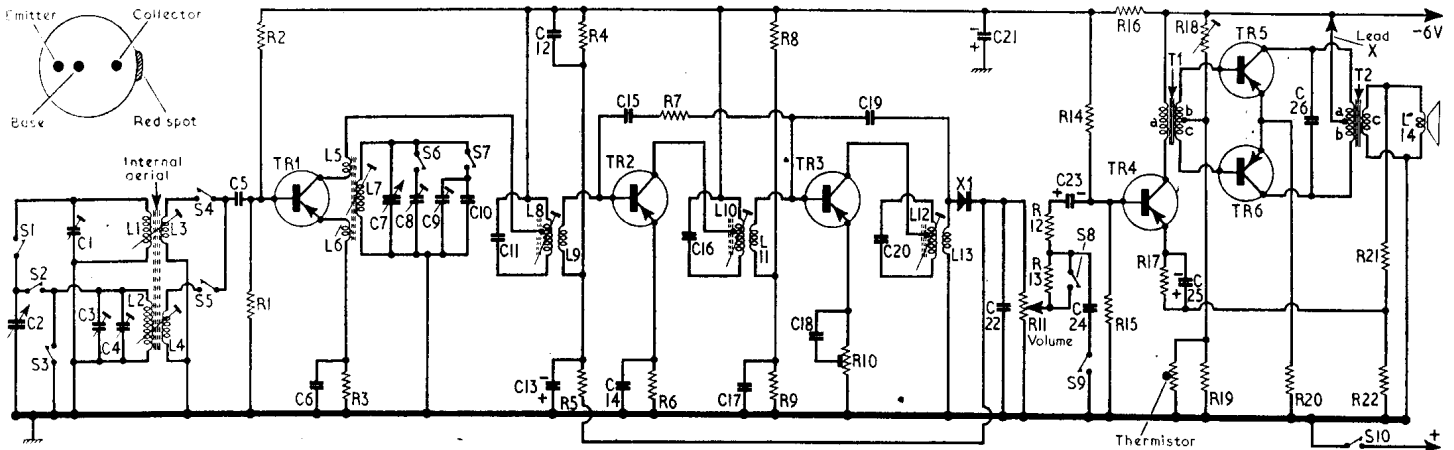

Circuit diagram of the Roberts RT.1. Base bias for TR5 and TR6 is provided by the potential divider formed by R18, R19 with R18 employed as a variable pre-set adjustment. Variation in bias with temperature is compensated for by a thermistor in parallel with R19. In later versions R10 is a fixed resistor. Adjustment of R10 and R18 is described under "General Notes."

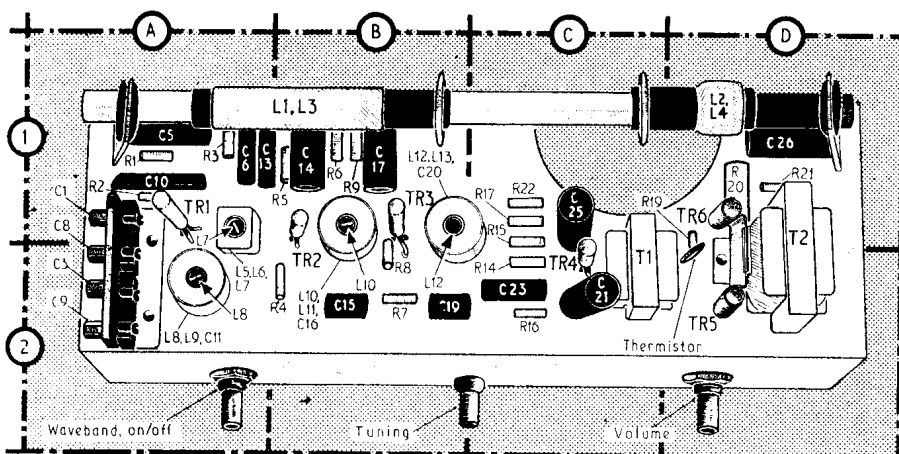

Plan view of the chassis. Note the metal clamp which is fitted around TR5 and TR6 in order to dissipate any heat.

Circuit Alignment—continued

pedance; a non-metallic trimming tool for core adjustments.

Connect the output meter in place of the speaker, or the A.C. voltmeter across winding c of T2. The output must be limited to 50mW (0.38V) to prevent A.G.C. action masking the adjustments.

Check that with the gang at maximum capacitance the cursor coincides with the high wavelength ends of the M.W. and L.W. scales.

L1 (B1) and L2 (D1) are ferrite rod tuned and should be adjusted for maximum output by sliding the formers along the ferrite rod and securing them to the rod after alignment to prevent them from moving. Carry out alignment as follows:—

- 1.—Switch receiver to M.W. Turn gang and volume control to maximum. Connect the signal generator between the junction of C5, S4 and chassis. Feed in a 470kc/s signal and adjust the cores of L12 (B1),

Switch Table

Switch	M.W.	L.W.
S1	C	—
S2	—	C
S3	C	—
S4	C	—
S5	—	C
S6	C	—
S7	—	C
S8	C	—
S9	—	C
S10	C	C

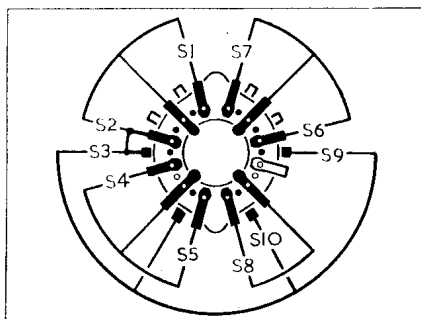

Above: Diagram of the switch unit as seen from the rear of an inverted chassis.

Right: Underside view of the chassis.

L10 (B1) and L8 (A2) for maximum output. Repeat these adjustments until no further improvement can be obtained.

- 2.—Loosely couple the signal generator output leads to the ferrite rod aerial. Tune the receiver to 500m, feed in a 600kc/s signal and adjust the core of L7 (A1) and the coil of L1 (B1) for maximum output.
- 3.—Tune the receiver to 214m, feed in a 1,400kc/s signal and adjust C8 (A2) and C1 (A1) for maximum output.
- 4.—Repeat operation 2 until no further improvement in output can be obtained.
- 5.—Repeat operations 3 and 4 for optimum response.
- 6.—Switch receiver to L.W. and tune it to Kalundborg, feed in a 245kc/s signal and adjust C9 (A2) and C3 (A2) for maximum output. C4 (E3) may be set to minimum or maximum according to the range required on C3.
- 7.—Tune the receiver to Paris, feed in a 164kc/s signal and adjust the coil of L2 (D1) for maximum output.
- 8.—Repeat operations 6 and 7 for optimum response.

GENERAL NOTES

Switches.—S1-S10 are the combined waveband and battery switches, ganged in a single rotary unit and shown in our underside plan view of the chassis in location reference E3. This unit is also shown in detail in the diagram in col. 1, where it is drawn as seen from the rear of an inverted chassis. Above it is the associated table, giving the switch positions for the two "on" positions. The control knob is turned clockwise for M.W., and anti-clockwise for L.W.

Warning.—Transistors may be permanently damaged if the full negative battery voltage is connected to their bases, or if continuity

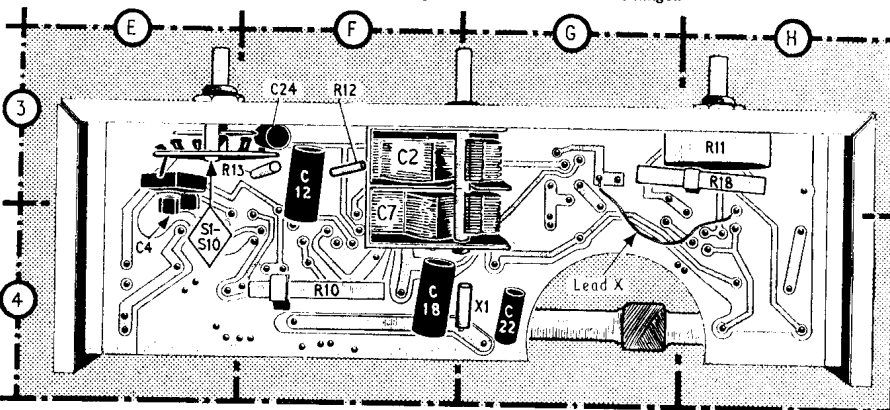

measurements are made with the transistors in circuit. If a transistor has to be removed or replaced, the soldering or unsoldering operation should be completed as quickly as possible, and a heat shunt such as a pair of pliers should be clamped across the transistor lead between the transistor and the soldering iron during the soldering or unsoldering of its leads. When replacing a transistor the leads should not be cut shorter than 1/8 inch.

Printed circuit.—To avoid damaging the printed circuit with excessive heat, use a soldering iron with a small tip and having a maximum rating of 60W. The iron should be applied to the joint only long enough for the solder to flow, and then quickly removed. Avoid running solder into adjoining circuits. Resistors and capacitors may be replaced by clipping out the defective component, leaving enough of the original connecting wire to solder to the new component.

Instability.—The positions of X1, C22 and C18 should not be altered, or instability may result.

Battery.—The battery recommended by the manufacturers is an Ever Ready type PP8, rated at 6V.

Modifications.—In early versions of this receiver C12, C24, S9 are omitted and R13 is 4.7kΩ.

Pre-set Resistors.—R10 was pre-set in our sample receiver, but will normally be 470Ω fixed. Where pre-set is fitted, it is adjusted at the works and should in no circumstances be readjusted.

R18 pre-set requires adjustment only if an output transistor is replaced, as explained below the transistor analysis table. A black flexible lead beneath the chassis (lead X, location G3) can be conveniently unsoldered to insert the milliammeter in series with the negative battery feed at the tapping on T2 primary.

TRANSISTOR ANALYSIS

Voltages and currents given in the table below are those derived from the manufacturers' information. Except where otherwise indicated, they were measured on the 10V range of a model 8 Avometer, chassis being the positive connection in every case. With no signal input the total battery current is 11mA, increasing to 90mA at 300mW output.

|--|