

"TRADER" SERVICE SHEET
1759

ROBERTS R700

*A.M./F.M. Transistor
Portable Radio Receiver*

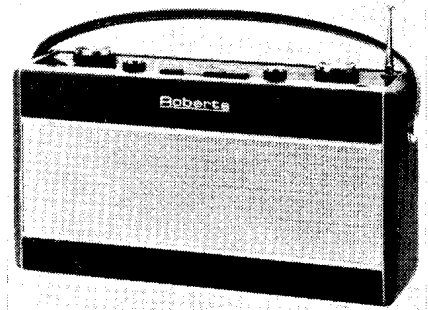

FEATURING automatic frequency control on f.m. and separate bass and treble tone controls, Roberts R700 is a three waveband a.m./f.m. portable radio receiver. It is powered by two 9V dry batteries and employs a total of 14 transistors and 8 diodes.

with reception via a ferrite rod a.m. aerial and a telescopic f.m. aerial.

Socket facilities provide for the connection of an earphone, which automatically mutes the loudspeaker when the plug is inserted, and a car type aerial.

(Continued overleaf col. 1)

Waveband ranges are 183-577m. (m.w.), 1,120-2,000m. (l.w.) and 87-108Mc/s (f.m.)

C	37	1	CV6,2	3	4	CV1,6,9,7	8	10	CV4,12	13	16	11	15	14,19	18	17	20	21,24	23	22	25	27	29		
R	CV5	1	38	CV7	3	28,4	6	44,42	CV8, CV3, 45, CV9, 43, 41, CV10	47	48	49	35, RV1	12, 38, 9	37	50, 46, 51, 54	52	55	15	16	17	13	19		
						29	5	32		31	34	33	10						39, 14		42	41	40	43	18

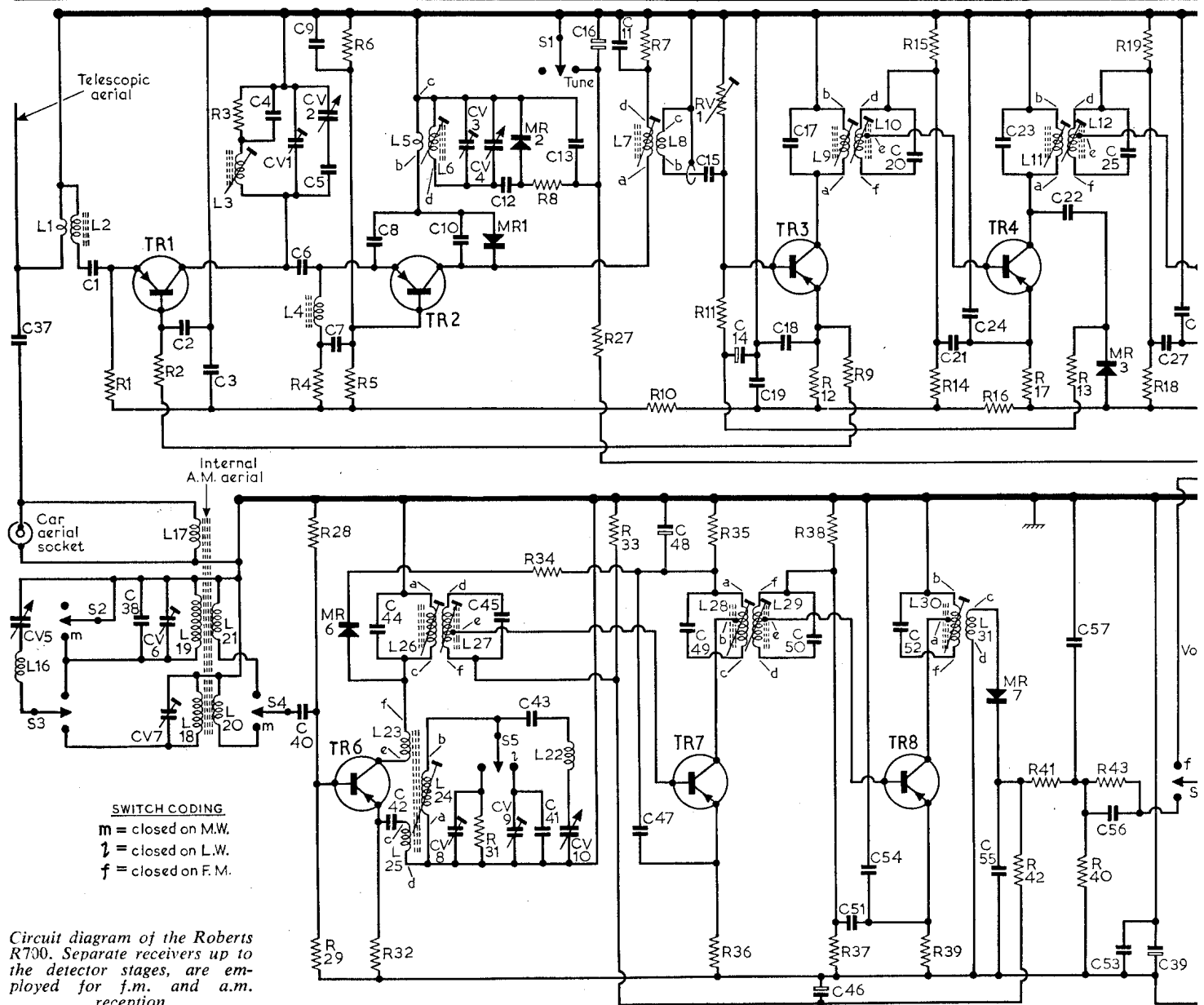

Resistors			Resistors			Resistors			Capacitors		
R1	1kΩ	A1	R25	560Ω	B2	R50	3.3kΩ	C1	C1	1,000pF	A1
R2	1kΩ	A1	R26	1kΩ	B1	R51	1kΩ	C1	C2	1,000pF	A1
R3	220Ω	A1	R27	68kΩ	B1	R52	3.3kΩ	C1	C3	0.1μF	A1
R4	1kΩ	A1	R28	33kΩ	B2	R53	10kΩ	C1	C4	0.01μF	A1
R5	3.3kΩ	A2	R29	6.8kΩ	B1	R54	82kΩ	C2	C5	100pF	A1
R6	22kΩ	A2	R30	3kΩ	B1	R55	1kΩ	C2	C6	2.2pF	A2
R7	220Ω	A2	R31	180kΩ	B1	R56	5.6kΩ	C2	C7	270pF	A1
R8	82kΩ	A2	R32	1kΩ	B1	R57	2.7kΩ	C2	C8	8.2pF	A2
R9	3.3kΩ	A1	R33	68kΩ	B2	R58	12kΩ	C2	C9	1,000pF	A2
R10	22Ω	A1	R34	1kΩ	C2	R59	6.8kΩ	C2	C10	68pF	A2
R11	3.3kΩ	A1	R35	1kΩ	C2	R60	10Ω	C2	C11	0.01μF	A2
R12	1kΩ	A1	R36	560Ω	C2	R61	1.5kΩ	C2	C12	8.2pF	A2
R13	5.6kΩ	B1	R37	4.7kΩ	C1	R62	1.2kΩ	C2	C13	1,000pF	A2
R14	3.3kΩ	B1	R38	22kΩ	C1	R63	82Ω	C2	C14	2μF	A1
R15	22kΩ	A2	R39	1kΩ	C1	R64	1.5kΩ	C1	C15	0.01μF	A1
R16	56Ω	B1	R40	4.7kΩ	C1	R65	2.2Ω	C1	C16	2μF	A2
R17	1kΩ	B1	R41	1kΩ	C1	R66	2.2Ω	C1	C17	180pF	B2
R18	5.6kΩ	B1	R42	10kΩ	C1	R67	330Ω	C2	C18	0.01μF	A1
R19	6.8kΩ	B2	R43	56kΩ	B1	RV1	100kΩ	A1	C19	0.1μF	A1
R20	220Ω	B1	R44	68kΩ	C1	RV2	22kΩ	B2	C20	180pF	B2
R21	3.3kΩ	B1	R45	10kΩ	C1	RV3	20kΩ	D3	C21	0.01μF	B1
R22	150Ω	B1	R46	2.2kΩ	C1	RV4	50kΩ	D3	C22	5pF	B1
R23	330Ω	B1	R47	330Ω	C1	RV5	50kΩ	D3	C23	180pF	B2
R24	1kΩ	B2	R48	15kΩ	C1	RV6	10kΩ	C2	C24	0.01μF	B1
			R49	3.3kΩ	C1	RV7	220Ω	C1	C25	180pF	B2

27	29	31	26	28	30	32,35	67	36
39	58	59	60	63,65,34	61,33,62	64	66	
19	21	44	20,23	22	RV5	52,26	24,25, RV2	54
18	30	RV3	45	48,47,46	49	50	RV4	51
								53

The component numbers in these tables correspond with those used in the receiver manufacturer's service manual

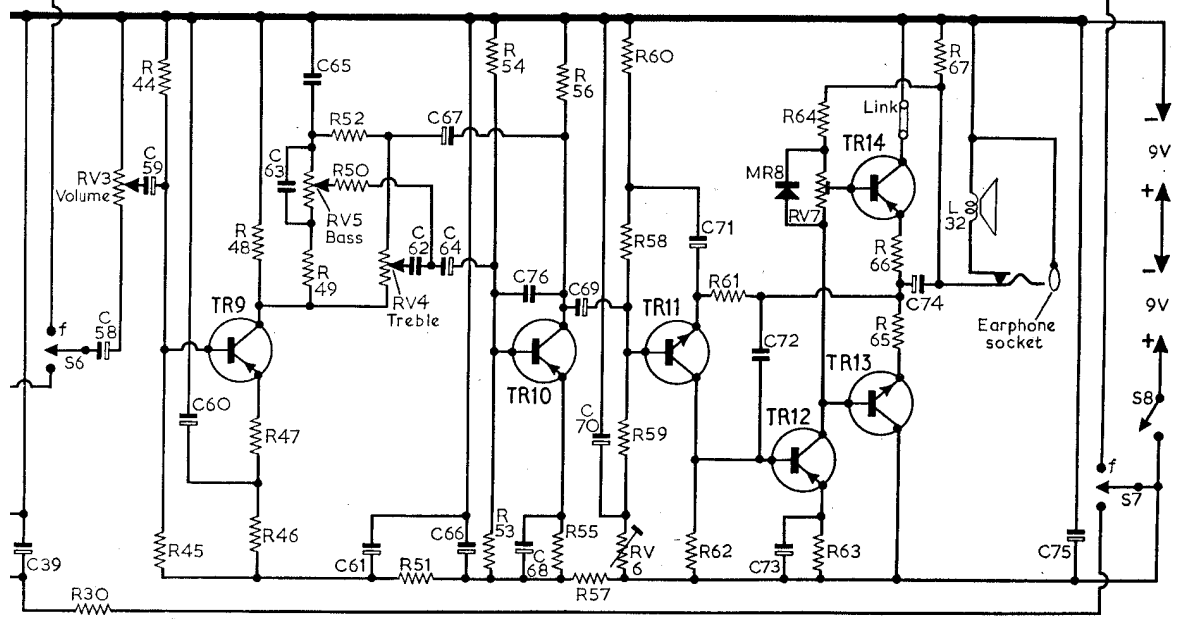
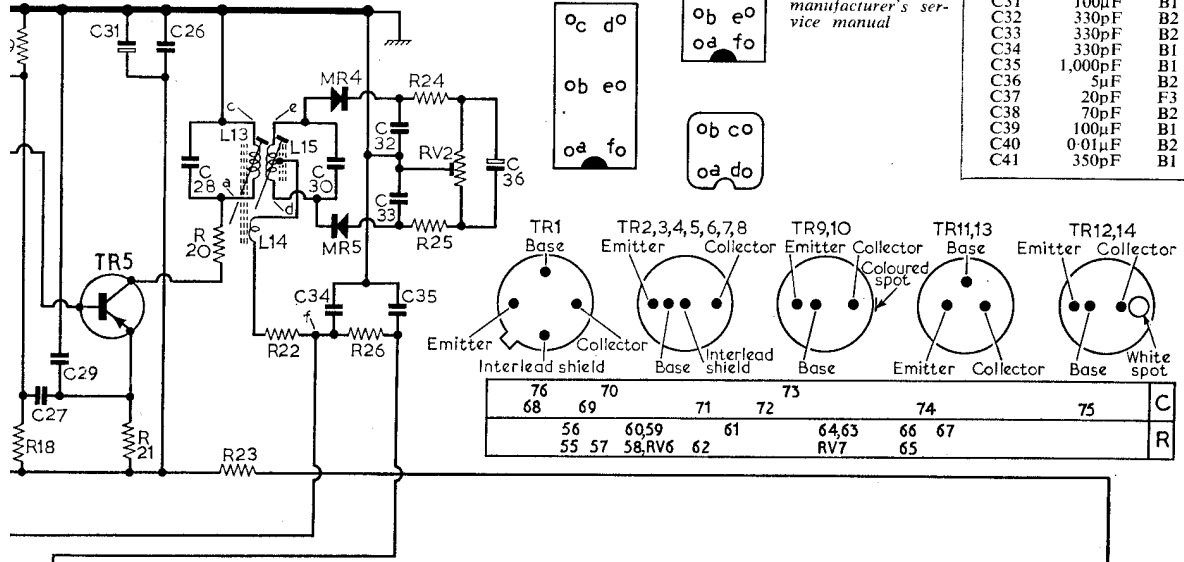

C42	0.022μF	B1
C43	440pF	B1
C44	560pF	C2
C45	560pF	C2
C46	10μF	B2
C47	0.047μF	B2
C48	2μF	B1
C49	270pF	C2
C50	270pF	C2
C51	0.022μF	B1
C52	250pF	C1
C53	0.022μF	B2
C54	0.022μF	B1
C55	0.01μF	C1
C56	5,000pF	B1
C57	0.01μF	C1
C58	0.5μF	D3
C59	1μF	D3
C60	100μF	C1
C61	100μF	C1
C62	0.01μF	C1
C63	0.047μF	D3
C64	2μF	C2
C65	0.022μF	C1
C66	100μF	C2
C67	2μF	C2
C68	100μF	C2
C69	2μF	C2
C70	100μF	C2
C71	175μF	C2
C72	500pF	C2
C73	100μF	C2
C74	350μF	C2
C75	100μF	C2
C76	2,000pF	D3
CV1	20pF	A1
CV2	15pF	F3
CV3	10pF	D3
CV4	15pF	F3
CV5	392pF	F3
CV6	80pF	B2
CV7	40pF	B2
CV8	40pF	B1
CV9	80pF	B1
CV10	392pF	F3

Coils		
L1	—	A1
L2	—	A1
L3	—	A1
L4	—	A2
L5	—	A2
L6	—	A2
L7	—	A2
L8	—	A2
L9	—	A2
L10	—	A1
L11	—	A2
L12	—	B1
L13	—	B2
L14	—	B1
L15	—	B2
L16	—	A2
L17	—	C2
L18	—	B2
L19	—	C2
L20	—	B2
L21	—	C2
L22	—	A1
L23	—	B2
L24	—	B2
L25	—	B2
L26	—	C2
L27	—	C2
L28	—	B2
L29	—	C2
L30	—	C1
L31	—	C1
L32	25Ω	—

Transistors		
TR1	AF180	A1
TR2	AF114	A2
TR3	AF114	A1
TR4	AF114	B1
TR5	AF114	B1
TR6	AF117	B2
TR7	AF117	C2
TR8	AF117	C1
TR9	OC71	C1
TR10	OC75	C2
TR11	AC127	C2
TR12	OC81D	C2
TR13	AC127	C1
TR14	OC81	C1

Diodes		
MR1	AA119	A2
MR2	BA102	A2
MR3	AA119	B1
MR4	AA119	B2
MR5	AA119	B2
MR6	AA119	C2
MR7	OA90	C1
MR8	BA114	C1

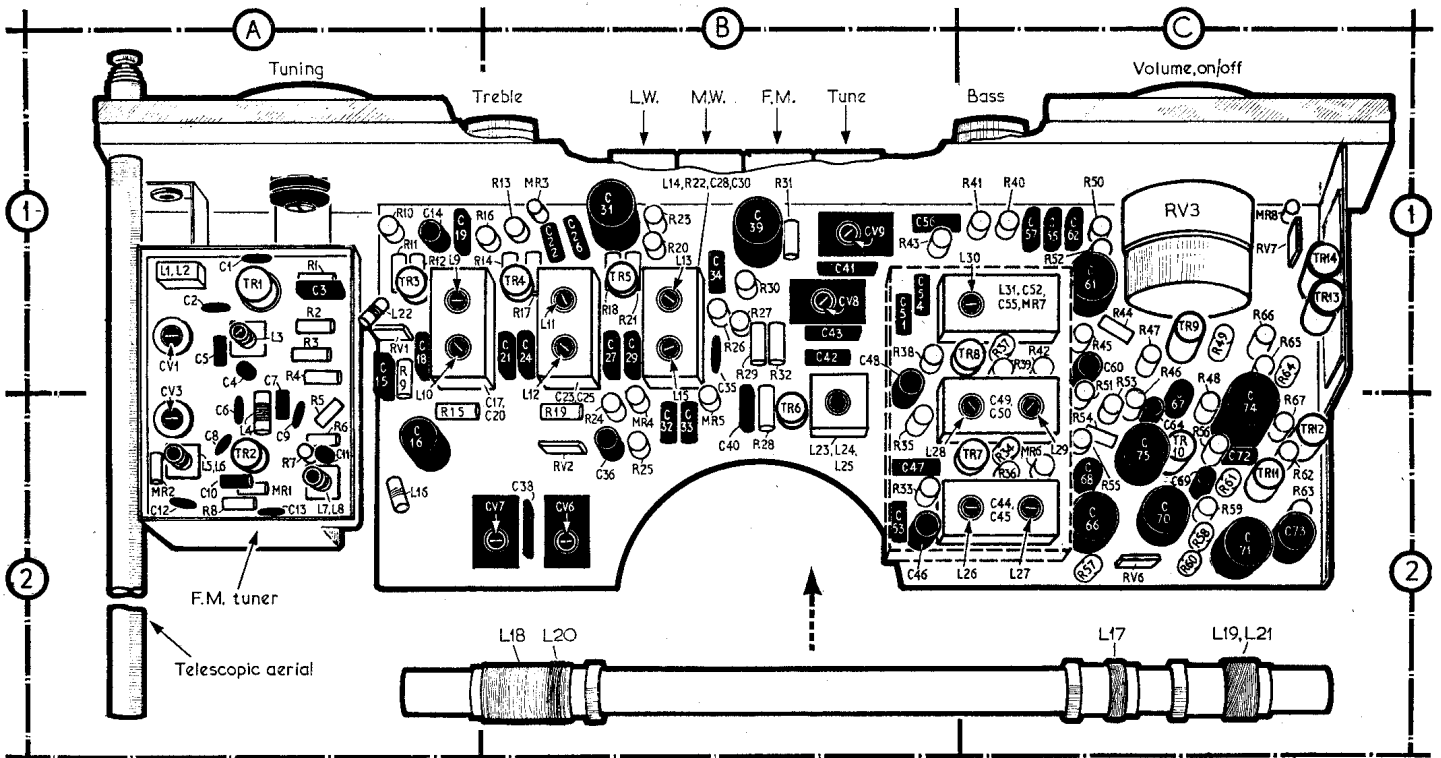

The chassis as seen from the component side of the printed panel. For ease of servicing the receiver can be withdrawn from the case in one complete unit with only the speaker remaining

Continued from overleaf

CIRCUIT DESCRIPTION

The circuit comprises two independent receivers, one for the reception of f.m. signals and one for a.m. signals, up to and including the detector output, followed by a common audio channel featuring a complementary output stage. TR1 to TR5 operate on f.m. only, TR6 to TR8 operate on a.m. only and TR9 to TR14 are common to both modes of operation. Battery supply is switched to the appropriate receiver section by the action of S7.

On f.m., TR1 and TR2 are connected as earthed base r.f. amplifier and self-oscillating mixer stages respectively. R.f. signals developed across the broad band aerial transformer L1/L2 are coupled via C1 to the emitter of TR1. An a.g.c. bias for TR1 is derived from the potential across TR3 emitter resistor R12 which is fed to the base via R9 and R2.

The tuned circuit L3, CV1, CV2, C5, R3 and C4 form TR1 collector load impedance and signals developed across the load are fed via C6, and the 10.7Mc/s trap L4, to the emitter of TR2. Local oscillator signals are generated by the tuned circuit CV3, CV4, C12 and L6 shunted by the a.f.c. diode MR2 with collector to emitter feedback via C10 and C8. A reference signal for the a.f.c. circuit is derived from the ratio detector output via R27 and this reference is short-circuited to chassis via S1 while the receiver is being tuned to render the a.f.c. inoperative.

The 10.7Mc/s i.f. component in TR2 collector is coupled via L7/L8 to a conventional three-stage i.f. amplifier and applied to the ratio detector diodes MR4 and MR5 via the discriminator transformer L13-L15. I.f. signals at the collector of TR4 are fed via C22 to an a.g.c. diode MR3. Positive d.c. from MR3 is filtered by R13 and C14 and applied via R11, to TR3 base as a.g.c. bias. Initial level of TR3 bias is achieved by the setting of potentiometer RV1. Audio output from the f.m. detector is coupled via S6 and C58 to the volume control RV3.

On a.m., signals induced in the ferrite rod aerial are tuned by L18, CV7, L16 and CV5 (m.w.), and L19, CV6, C38, L16 and CV5

(l.w.) and are inductively coupled via L20 or L21 to the base of TR6 which operates as a self-oscillating mixer. Base bias for TR6 is set by the potential divider R28, R29 in conjunction with emitter resistor R32. The oscillator coil L24 is tuned by C43, L22 and CV10 in parallel with CV8 and R31 (m.w.), and CV9 and C41 (l.w.).

I.f. signals in TR6 collector at 470kc/s are passed via the double-tuned transformer L26, L27 to a two-stage i.f. amplifier TR7 and TR8. TR7 is an a.g.c. controlled stage. Its base is connected in the potential dividing network R33, R42, R41 and R40 from which the initial forward bias is derived. On receipt of a signal, this bias is backed off by a positive d.c. developed across R40 and R41 due to rectified carrier current output from MR7.

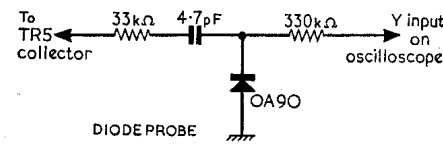

On strong signals, the consequent fall in TR7 collector current through R35 due to normal a.g.c. action, lifts the reverse bias on diode MR6 causing it to conduct, damping L26 with a low resistance shunt to prevent overloading. Audio output from the detector MR7 is filtered by R41 and C57 and fed via correction components R43 and C56 to the volume control.

Signals arriving at the volume control are applied via C59 to the audio amplifier TR9. Connected in the coupling between TR9 and a second amplifier TR10 are the tone controls RV5 (bass) and RV4 (treble) and their associated frequency correction components. Transistors TR11 to TR14 are connected in d.c. stabilised amplifier and output-stages using a complementary pair (TR13 and TR14) to achieve transformerless phase-splitting. Output balance is obtained by adjustment to RV6 and output stage quiescent current conditions by adjustment to RV7. 18V operating

supply is obtained from two 9V batteries connected in series.

CIRCUIT VOLTAGES

Circuit voltages quoted below and in the transistor table in col. 5 were taken from information supplied by the manufacturers.

They were measured on a model 8 Avometer with no signal input and the volume control set at minimum. All voltages are positive with respect to chassis.

Voltage measured:

- Across C75, 18V.
- Across C66, 12.25V.
- Across C61, 11.5V.
- Across C39, 6.72V.
- Across C31, 14.7V.
- Across C19, 14.25V.
- Across C3, 14.2V.

The total receiver quiescent current was 15mA (a.m.) and 21mA (f.m.).

CIRCUIT ALIGNMENT

Check that with the tuning gang fully meshed the cursor coincides with three datum pips at the left-hand end of the tuning scale. Calibration marks are printed on the l.w. scale at 1,141m. and 1,911m.

During alignment the input signal should be kept as low as possible to prevent a.g.c. action.

Equipment Required.—A wobulator with a centre frequency of 470kc/s, and 10.7Mc/s with markers; an a.m. signal generator; an f.m. signal generator; an audio output meter with an impedance to match 25Ω or, alternatively, an a.c. voltmeter; an oscilloscope; a diode detector probe made up as shown in the diagram in col. 2; a 10kΩ resistor and an r.f. coupling coil.

A.M. Circuits

- 1.—Connect the wobulator to the r.f. coil and couple the coil to the ferrite rod aerial. Connect the oscilloscope across R40.
- 2.—Switch receiver to m.w. and tune to the 1,911 m. mark. Feed in 470kc/s signal and adjust the cores of L26 to L30 for maximum gain and symmetry of the response curve.

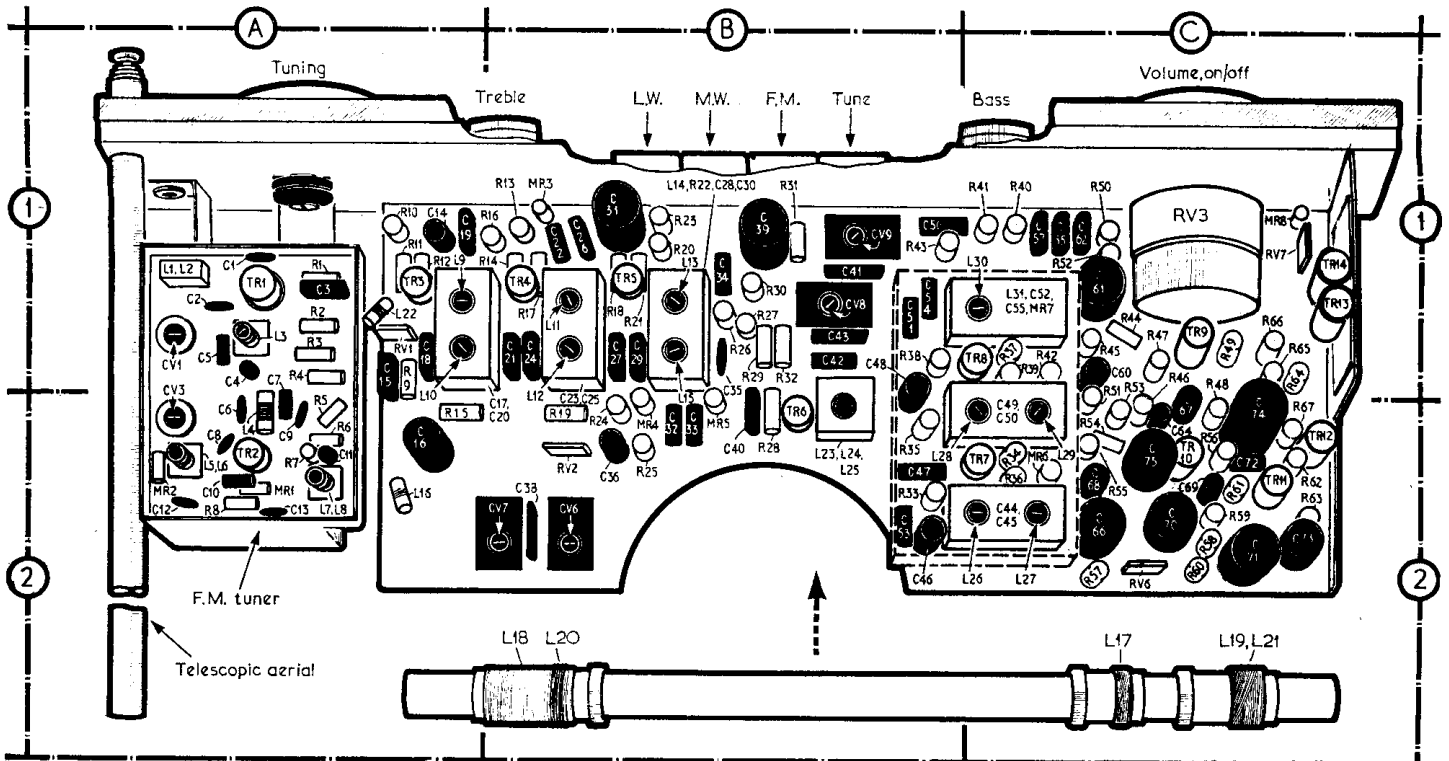

The chassis as seen from the component side of the printed panel. For ease of servicing the receiver can be withdrawn from the case in one complete unit with only the speaker remaining

Continued from overleaf

CIRCUIT DESCRIPTION

The circuit comprises two independent receivers, one for the reception of f.m. signals and one for a.m. signals, up to and including the detector output, followed by a common audio channel featuring a complementary output stage. TR1 to TR5 operate on f.m. only, TR6 to TR8 operate on a.m. only and TR9 to TR14 are common to both modes of operation. Battery supply is switched to the appropriate receiver section by the action of S7.

On f.m., TR1 and TR2 are connected as earthed base r.f. amplifier and self-oscillating mixer stages respectively. R.f. signals developed across the broad band aerial transformer L1/L2 are coupled via C1 to the emitter of TR1. An a.g.c. bias for TR1 is derived from the potential across TR3 emitter resistor R12 which is fed to the base via R9 and R2.

The tuned circuit L3, CV1, CV2, C5, R3 and C4 form TR1 collector load impedance and signals developed across the load are fed via C6, and the 10.7Mc/s trap L4, to the emitter of TR2. Local oscillator signals are generated by the tuned circuit CV3, CV4, C12 and L6 shunted by the a.f.c. diode MR2 with collector to emitter feedback via C10 and C8. A reference signal for the a.f.c. circuit is derived from the ratio detector output via R27 and this reference is short-circuited to chassis via S1 while the receiver is being tuned to render the a.f.c. inoperative.

The 10.7Mc/s i.f. component in TR2 collector is coupled via L7/L8 to a conventional three-stage i.f. amplifier and applied to the ratio detector diodes MR4 and MR5 via the discriminator transformer L13-L15. I.f. signals at the collector of TR4 are fed via C22 to an a.g.c. diode MR3. Positive d.c. from MR3 is filtered by R13 and C14 and applied via R11, to TR3 base as a.g.c. bias. Initial level of TR3 bias is achieved by the setting of potentiometer RV1. Audio output from the f.m. detector is coupled via S6 and C58 to the volume control RV3.

On a.m., signals induced in the ferrite rod aerial are tuned by L18, CV7, L16 and CV5 (m.w.), and L19, CV6, C38, L16 and CV5

(l.w.) and are inductively coupled via L20 or L21 to the base of TR6 which operates as a self-oscillating mixer. Base bias for TR6 is set by the potential divider R28, R29 in conjunction with emitter resistor R32. The oscillator coil L24 is tuned by C43, L22 and CV10 in parallel with CV8 and R31 (m.w.), and CV9 and C41 (l.w.).

I.f. signals in TR6 collector at 470kc/s are passed via the double-tuned transformer L26, L27 to a two-stage i.f. amplifier TR7 and TR8. TR7 is an a.g.c. controlled stage. Its base is connected in the potential dividing network R33, R42, R41 and R40 from which the initial forward bias is derived. On receipt of a signal, this bias is backed off by a positive d.c. developed across R40 and R41 due to rectified carrier current output from MR7.

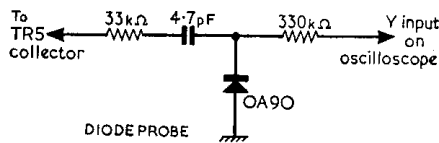

On strong signals, the consequent fall in TR7 collector current through R35 due to normal a.g.c. action, lifts the reverse bias on diode MR6 causing it to conduct, damping L26 with a low resistance shunt to prevent overloading. Audio output from the detector MR7 is filtered by R41 and C57 and fed via correction components R43 and C56 to the volume control.

Signals arriving at the volume control are applied via C59 to the audio amplifier TR9. Connected in the coupling between TR9 and a second amplifier TR10 are the tone controls RV5 (bass) and RV4 (treble) and their associated frequency correction components. Transistors TR11 to TR14 are connected in d.c. stabilised amplifier and output-stages using a complementary pair (TR13 and TR14) to achieve transformerless phase-splitting. Output balance is obtained by adjustment to RV6 and output stage quiescent current conditions by adjustment to RV7. 18V operating

supply is obtained from two 9V batteries connected in series.

CIRCUIT VOLTAGES

Circuit voltages quoted below and in the transistor table in col. 5 were taken from information supplied by the manufacturers.

They were measured on a model 8 Avometer with no signal input and the volume control set at minimum. All voltages are positive with respect to chassis.

Voltage measured:

- Across C75, 18V.
- Across C66, 12.25V.
- Across C61, 11.5V.
- Across C39, 6.72V.
- Across C31, 14.7V.
- Across C19, 14.25V.
- Across C3, 14.2V.

The total receiver quiescent current was 15mA (a.m.) and 21mA (f.m.).

CIRCUIT ALIGNMENT

Check that with the tuning gang fully meshed the cursor coincides with three datum pips at the left-hand end of the tuning scale. Calibration marks are printed on the l.w. scale at 1,141m. and 1,911m.

During alignment the input signal should be kept as low as possible to prevent a.g.c. action.

Equipment Required.—A wobulator with a centre frequency of 470kc/s, and 10.7Mc/s with markers; an a.m. signal generator; an f.m. signal generator; an audio output meter with an impedance to match 25Ω or, alternatively, an a.c. voltmeter; an oscilloscope; a diode detector probe made up as shown in the diagram in col. 2; a 10kΩ resistor and an r.f. coupling coil.

A.M. Circuits

- 1.—Connect the wobulator to the r.f. coil and couple the coil to the ferrite rod aerial. Connect the oscilloscope across R40.
- 2.—Switch receiver to m.w. and tune to the 1,911 m. mark. Feed in 470kc/s signal and adjust the cores of L26 to L30 for maximum gain and symmetry of the response curve.