

THE AI46C RECEIVER

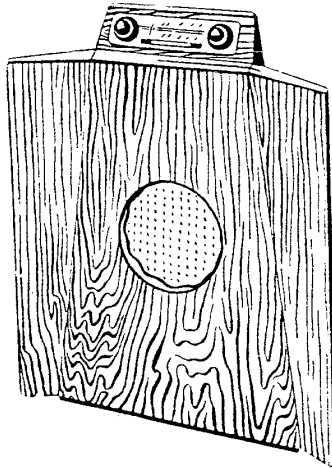

MAINS SUPPLY:	200-250 volts, a.c. 50-60 c/s.
WAVE RANGES:	Medium: 187-560 metres Long: 1000-2000 metres
INTERMEDIATE FREQUENCY:	465 Kc/s
VALVES:	Mazda: 10C1, 10F9, two 10LD11, two PEN45, UU6
SCALE LAMPS:	Two 6.2 volts, 0.3 amps (M.E.S.)
SPEECH COIL IMPEDANCE:	3 ohms
EXTENSION LOUDSPEAKER:	3 to 7 ohms
CABINET DIMENSIONS:	32 $\frac{1}{4}$ in. high, 26 in. wide, 9 in. deep at base
TOTAL WEIGHT:	35 lb.
CONSUMPTION:	62 watts
RELEASED:	September 1949
PRICE:	£28 12s. 9d. plus P.T.

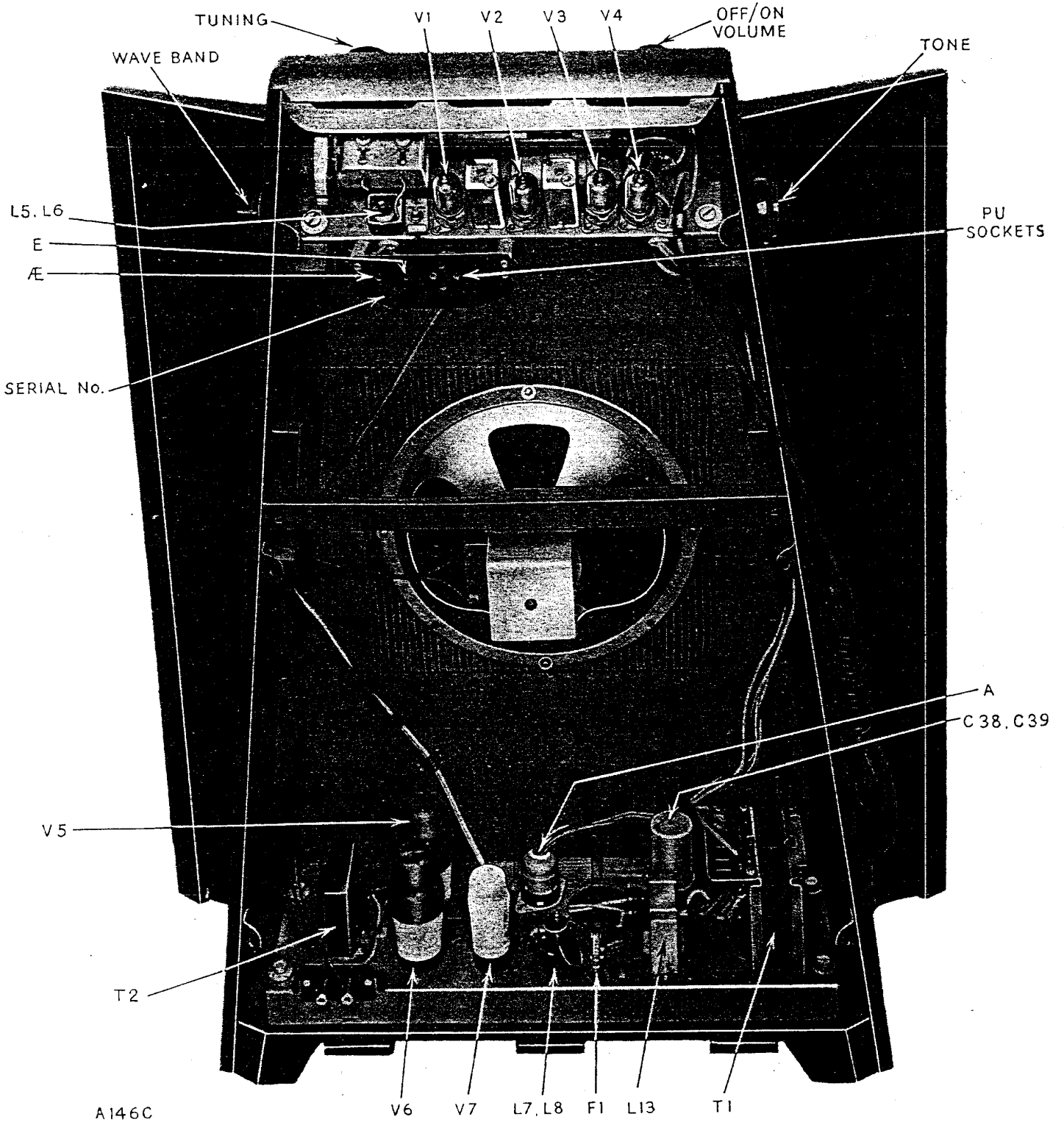

Fig. 1. Rear view of the complete receiver

ELECTRICAL NOTES

A conventional superhet type circuit is used in the r.f. and i.f. sections of the receiver, but in the a.f. sections special measures have been taken towards securing high quality reproduction.

The local oscillator circuit. On the medium wave band L6 is the tuned winding, L5 is the coupling winding, and C17 is the series padding capacitor. On the long wave band L6 and L5 in series form the inductor in a Colpitts type circuit, and C19 in series with C17 form the padding capacitor as well as one arm of the split capacitor. The other arm of the split capacitor is formed by C5, C7, C8, and C18 in parallel.

In later receivers the oscillator coil and circuit were modified to improve the medium wave band coverage and to simplify the adjustment of the oscillator coil cores. (See modifications under the heading "The Oscillator Circuit" on page 17.)

The automatic gain control (a.g.c.) circuit. Delayed a.g.c. is incorporated, a small delay voltage being provided by R13 and R14 in series.

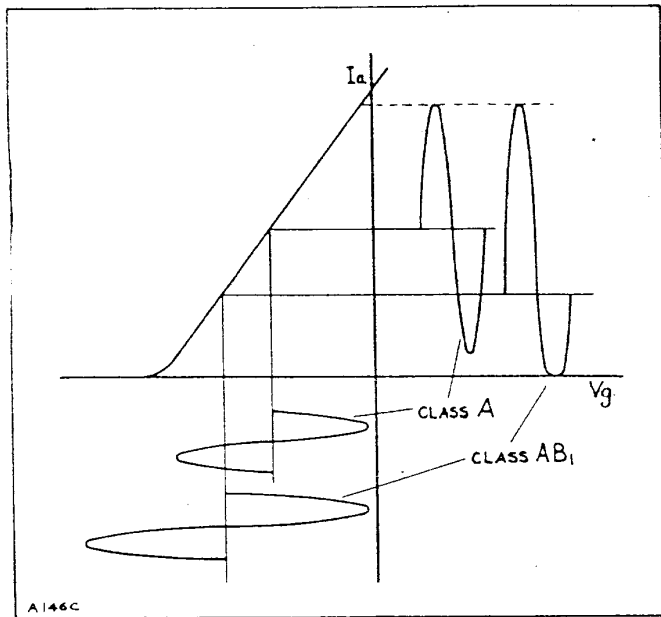

Fig. 2

The a.f. circuits. The a.f. amplifier consists of a 10LD11 valve (V3), a self-balanced phase-reversing valve (V4) which is also a 10LD11, and two PEN45 valves (V5 and V6) operated in "Class AB₁" push-pull. Voltage feedback is applied from a tertiary winding on the output transformer (T2) to the cathode of V3.

The values of R17, R18, and R19 have been chosen so that the inputs to V5 and V6 are equal and of opposite

phase, and so that the stage gain of V4 remains constant under widely varying conditions (including valve replacement). The constant stage gain is achieved by applying heavy negative feedback from anode to grid of V4 via R18.

In order to secure Class AB₁ operation of V5 and V6, their control grids are biased slightly more negatively than for Class A operation (see Fig. 2). This means that, on a strong signal, the valve does not run into grid current but a portion of the -ve going half cycles of signal to each valve are suppressed. Due to push-pull working, however, the output to the loudspeaker is quite linear (Fig. 3) and even order harmonics are

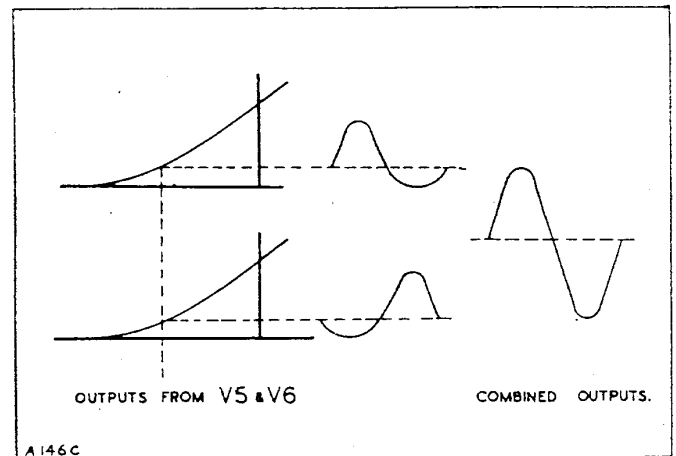

Fig. 3

argely cancelled. Additionally, due to the reduced standing anode current in V5 and V6 an appreciable economy in power supply components has been achieved. It should be noted that the anode current supply to V5 and V6 increases when the sound output is increased above a certain level.

The application of negative voltage feedback over the whole amplifier results in considerably reduced output impedance, which increases the damping of the loudspeaker, reduces the loudspeaker bass resonance and improves the reproduction of transients.

Adjustable tone correction at the high frequency end of the audio spectrum is achieved by varying the shunt capacitance in V3 anode circuit and in the main feedback circuit.

The volume control is partially tone compensated to take account of the fact that at low volume levels the human ear is less sensitive to the lower frequencies. The compensation is achieved because the volume control

(R11), C27, and R10 effectively form a potentiometer across the feedback resistor R14 (see Fig. 4) R13 being by-passed by the 50 μ F. capacitor C32. At the lower frequencies the impedance of C27 is high so that chang-

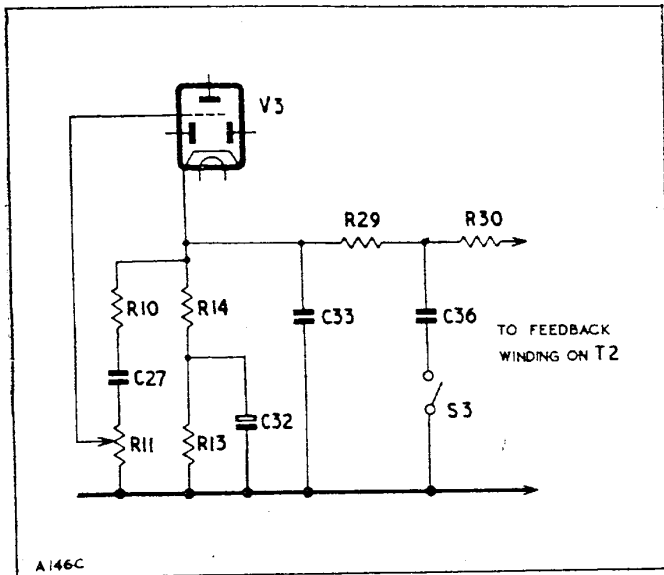

Fig. 4

ing from high to low volume produces little change in feedback. At the higher frequencies the impedance of C27 is low so that changing from high to low volume increases the feedback. The nett result is that changing

from high to low volume causes a relative increase in the lower frequency response of the whole amplifier.

The gramophone circuit. This is specifically designed for use with a crystal type pick-up and for reproducing standard 78 r.p.m. type records. An extra position on the wave band switch brings the gramophone circuits into use when required and the record player can be left permanently connected to the receiver. The two leads from the crystal itself should be connected to sockets "P" and "U" while the screening braid, which must be completely insulated from the pick-up leads and from the metal work of the record player, should be connected to socket "C".

If the hum level is above normal, reversing the mains supply connections or the connections to the "P" and "U" sockets may be helpful.

The power supply circuits. An auto transformer supplies the different voltages which are required and half wave rectification is used for the high tension d.c. supply. The heater of the rectifier (V7) is supplied from a small separate winding on this transformer.

WARNING

1. As the chassis of this receiver is connected to one side of the supply mains appropriate care should be exercised at all times.
2. The chassis inter-connecting plugs should not be extracted while the receiver is operating, because the output valves (V5 and V6) may be damaged.

MECHANICAL NOTES

To remove the chassis from the cabinet. First remove the cabinet back and then the control knobs. Disconnect the 4 pin plug and the 8 pin socket from the power unit and free the leads from the cleats. Disengage the drive cord from the pointer carrier and unscrew the two chassis fixing bolts. Ease the chassis gently from the cabinet until the clearance is sufficient to allow the removal of the pilot lamps from the scale supports.

To remove the tuning scale. Take off the two front control knobs (52278) and felt washers (34592), unclip the two scale retaining springs (54158) and lift the scale clear of the scale supports.

To remove the tuning pointer. Remove the tuning

scale as described above. Hold the pointer firmly at the bottom and pull directly away from the cabinet.

To refit the tuning pointer. The pointer (51634) fits into a holder (50045) which is mounted on a carrier (54393) as shown in the Cord Drive diagram on page 5. The carrier is attached to the pointer drive cord, and slides on the guide rail (50040). When replacing the pointer and holder, it should be pushed on to the carrier as far as it will go.

The cabinet. The cabinet (52298) is supplied with six back mounting brackets (57341) already fitted. The speaker baffle is not removable and when the speaker fabric needs renewing, a replacement speaker

fabric (1829/10) can be supplied separately on request.

The **loudspeaker** (52243) is fitted to the cabinet by means of four **wood screws** (102405). A **mounting ring** (54251) is placed between the loudspeaker and the baffle.

The pilot lamps. To ensure the maximum scale illumination, it is important that the lamp filaments should be in line with the slots in the scale supports.

For this reason, Philips **lamps** (16880) (6.2 volt 0.3 amp) are specified, as they are made to close mechanical tolerances and the filament assumes the correct position when the lamp is pushed fully into the scale support. The rubber **grommet** (42842) which surrounds the lamp holder ensures a secure mounting for the pilot lamp but care should be taken when inserting the lamps as the glass may be broken if too much pressure is used.

CORD DRIVE

To replace the drive cord (Spec. 936), tie one end of a 40 in. length to the **spring** (47478) and hook the spring on to the **tuning drum** (48189) as shown in the diagram. Pass the cord around the pulleys in the direction shown by the arrows, with the **eyelet** (15628) threaded on to the cord between the two lower pulleys. Make one turn around the tuning drum and tie the free end of the cord to the

spring, with the spring extended as far as possible.

Turn the tuning drum until the gang capacitor plates are fully meshed (check this by inspection) then clamp the eyelet on to the drive cord approximately $1\frac{1}{2}$ in. from the right-hand lower pulley. The eyelet serves as a datum point for calibration purposes and is referred to in the alignment instructions.

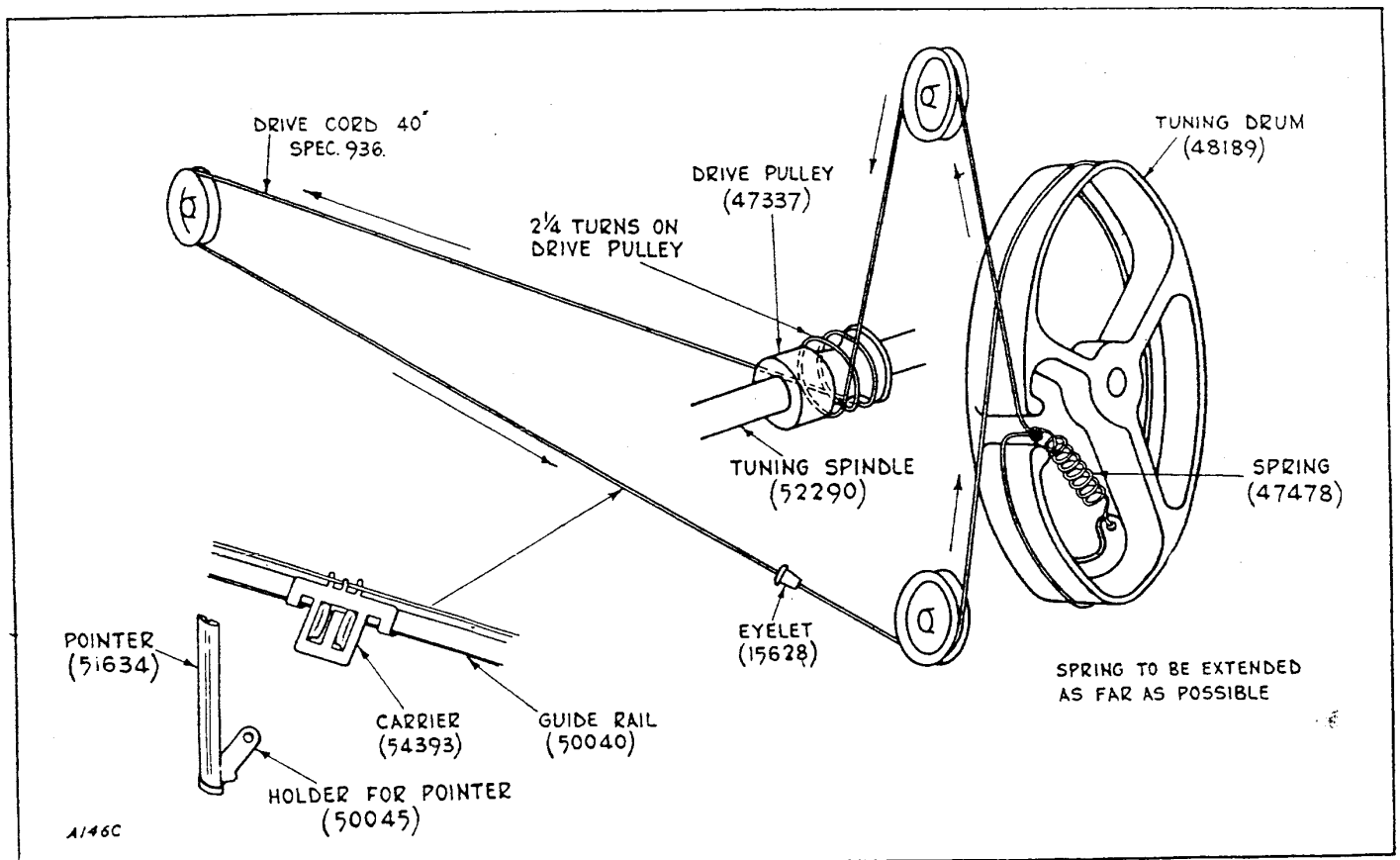

Fig. 5. The cord drive

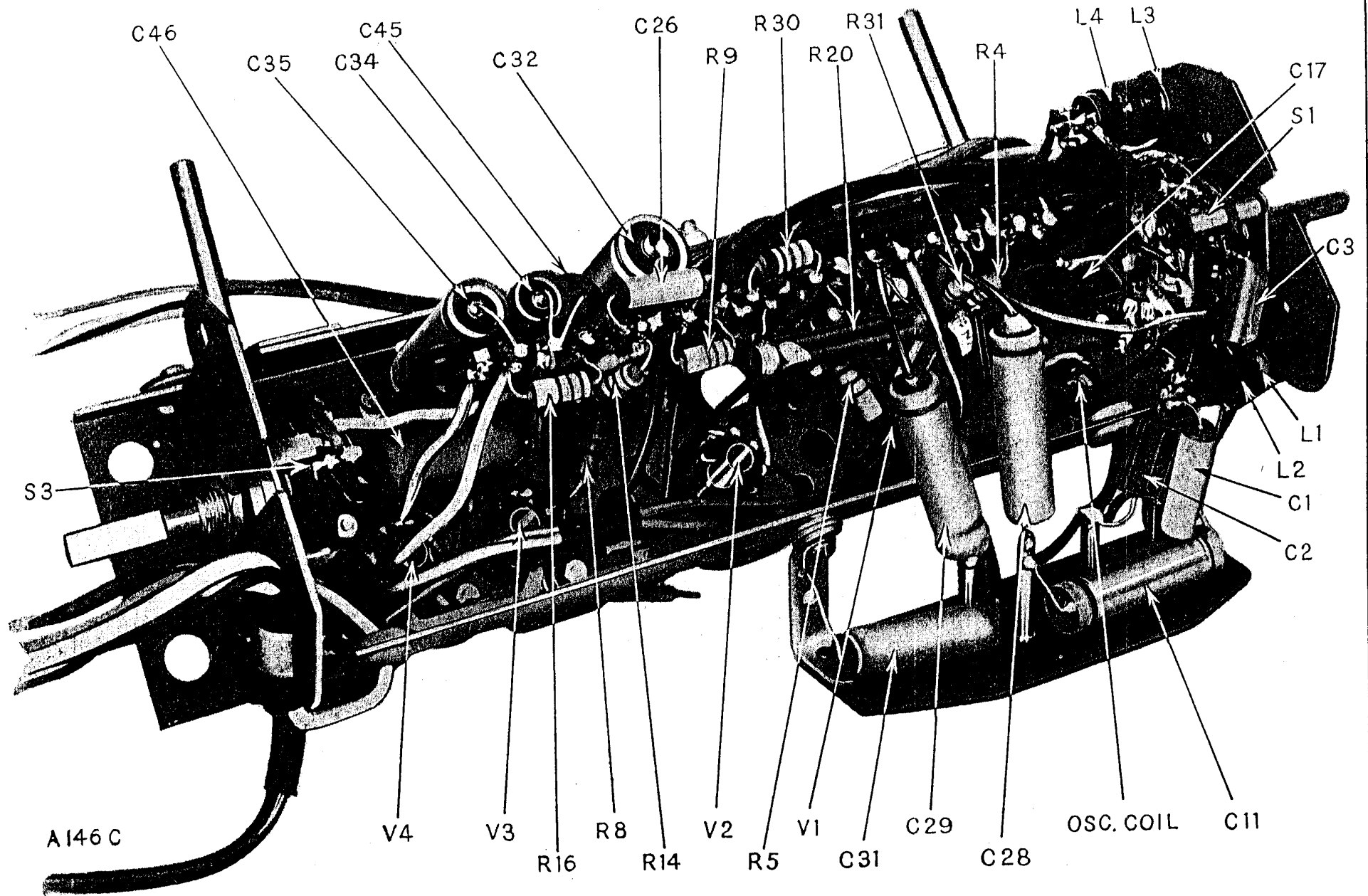

Fig. 6. Underneath view of the Receiver Chassis. The top view is on page 12.

CIRCUIT ALIGNMENT

(The Alignment Table is on page 9)

The chassis of this receiver is connected directly to one side of the mains supply and, before attempting any circuit adjustments, every precaution should be taken to minimize the possibility of receiving an electric shock or damaging the instruments being used.

All of the trimmers can be adjusted without removing the receiver chassis from the cabinet, but in case it is necessary to adjust the oscillator and aerial trimmers when the cabinet or tuning scale is not available, a 6-inch rule may be used as a scale. The traverse of an eyelet, which is fixed on the drive cord, **from the position which it occupies when the ganged capacitor is fully meshed**, is quoted in the "Circuit Alignment Table". When making this check remember that the ganged capacitor rotor will turn slightly beyond the fully meshed position.

The coil cores must be adjusted with a thin non-metallic screwdriver, shaped to fit the core slots (a thin plastic knitting needle can be shaped for the purpose). A metal screwdriver is unsuitable, as it will affect the inductance of the coils and may also cause damage to the cores.

With the volume control at maximum, make all adjustments to give maximum audio output; this output should not be allowed to exceed 1·2 volt as

measured with a low reading alternating voltage meter connected across the loudspeaker speech coil.

If difficulty is experienced due to interaction between the medium and long wave sections of the oscillator coil, restart the adjustments with each oscillator coil core set at $\frac{1}{2}$ in. from the end of the coil former. Commence with adjustments (e) and (g) in the alignment table and repeat these until the calibration is correct at the two wavelengths concerned. Then proceed according to the table.

Before making any calibration adjustments with the receiver chassis mounted inside the cabinet, make sure that when the gang capacitor vanes are fully meshed, the tuning pointer is beneath the spot on the tuning scale near the "550 metres" graduation.

The fully meshed, or maximum capacitance condition of the ganged capacitor is most easily checked with the blade of a small screwdriver. The blade should be inserted through one of the inspection holes in the capacitor cover and placed gently against the edges of the fixed plates near to the spindle; the spindle may then be turned until the rotor blades just touch the blade of the screwdriver.

PLEASE USE THE PARTS LIST WHEN ORDERING

R		28	19		18	16	14	10	13		29		20	35	31	3				R																				
C					35	34	33		25	32		26		30	23	22	30	29	44	15	19	17	9	18					C											
L									11	12				9	10												5	6			L									
MISC.	S ₃		V ₄		V ₃						V ₂					V ₁																			Slc.	Slc.	Slc.	Slb.	Slc.	MISC.

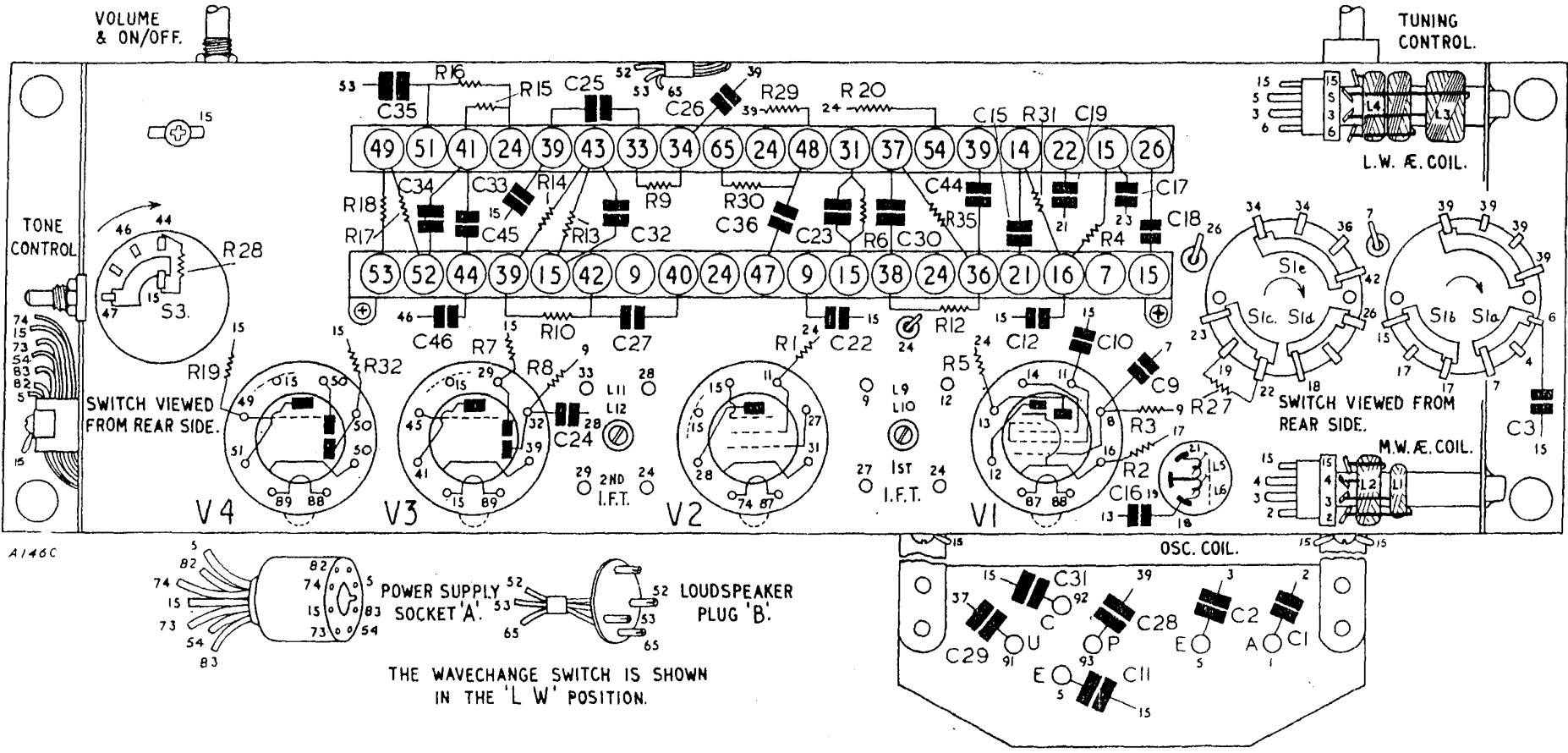

UNDERNEATH VIEW OF RECEIVER CHASSIS.
 Fig. 7. The diagram of the top of the receiver chassis is on page 13

CIRCUIT ALIGNMENT TABLE

Read "Circuit Alignment" before attempting any adjustments. It should be noted that in the receivers having the modified oscillator circuit, the positions of the oscillator coil windings and cores are interchanged as compared with the arrangement in the early models shown in the diagram facing this page. L15 and L16 relate to those chassis having the modified oscillator circuit.

CIRCUIT	SIG. GEN. FREQUENCY	SIG. GEN. TERMINATION	CONNECT SIG. GEN. TO	RECEIVER WAVE BAND	RECEIVER SCALE SETTING	TRAVERSE	NOTES	ADJUSTMENTS
2nd i.f.t.	465 Kc/s	Via 0.1 μ F. capacitor	C4 (test point 7) on gang capacitor	M	500 metres	0.93 in.	Unscrew secondary core (top of can) to fullest extent before adjusting	(a) L11 (pri) under chassis (b) L12 (sec) top of can DO NOT READJUST
1st i.f.t.								(c) L9 (pri) under chassis (d) L10 (sec) top of can DO NOT READJUST
Medium Waves	600 Kc/s (500 m.)	Via Dummy Aerial	Aerial Socket	M	500 metres	0.93 in.	Repeat these adjustments until the optimum calibration is obtained (see "Circuit Alignment")	(e) M.W. osc. coil (L6 or L16) (f) M.W. Ae. coil (L2)
Long Waves	158 Kc/s (1900 m.)			L	1900 metres	0.73 in.		(g) L.W. osc. coil (L5 or L15) (h) L.W. Ae. coil (L4)
Medium Waves	1363 Kc/s (220 m.)			M	220 metres	3.49 in.		(i) M.W. osc. trimmer (C7) (j) M.W. Ae. trimmer (C6)
Long Waves	300 Kc/s (1000 m.)			L	1000 metres	3.77 in.		(k) L.W. osc. trimmer (C8)

AI46C

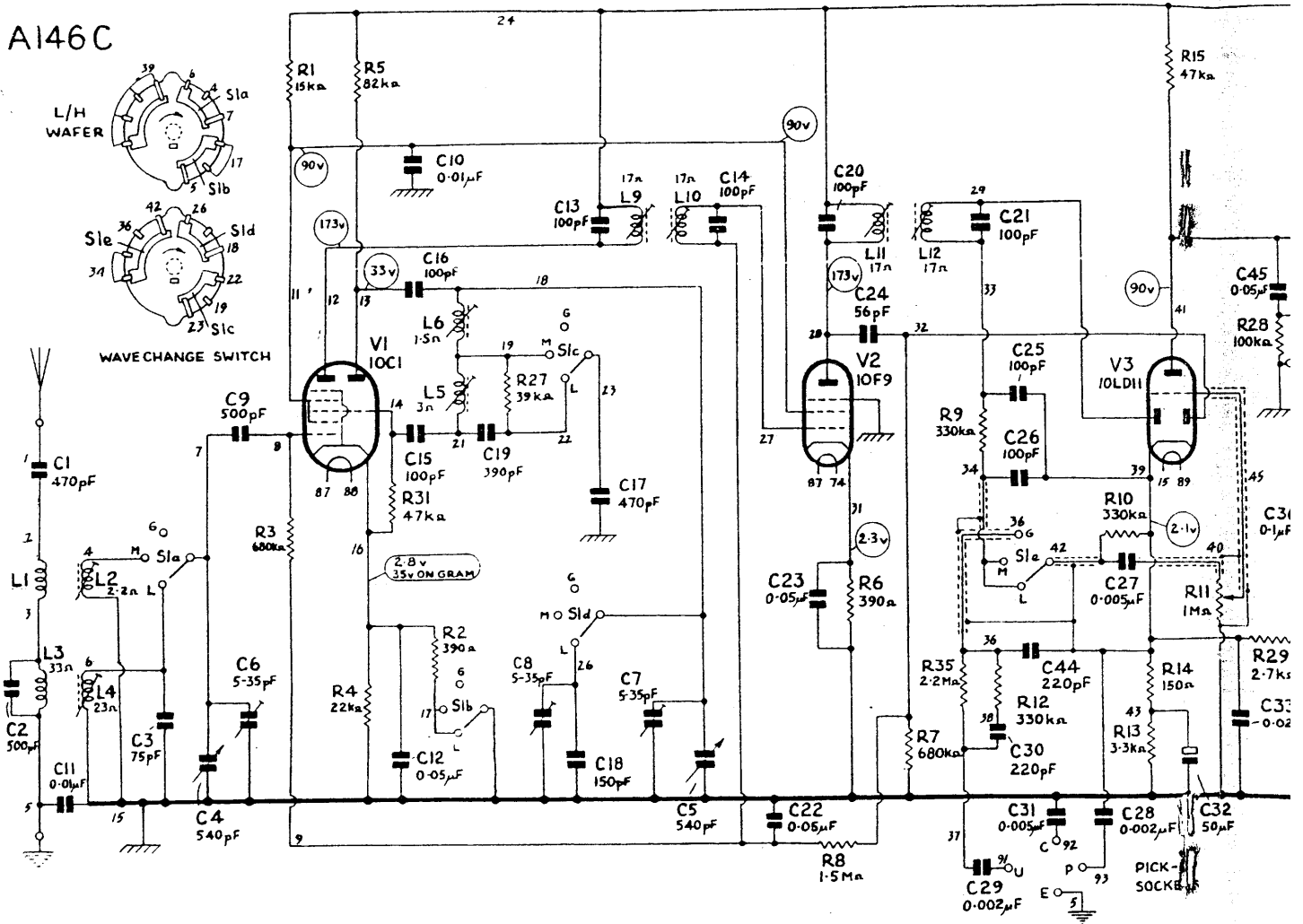
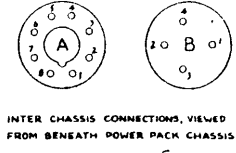
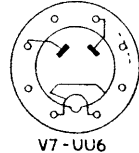
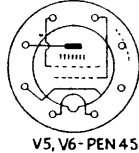
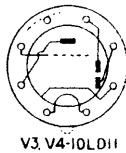
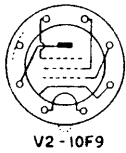
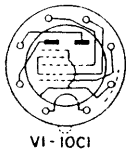

Fig. 8



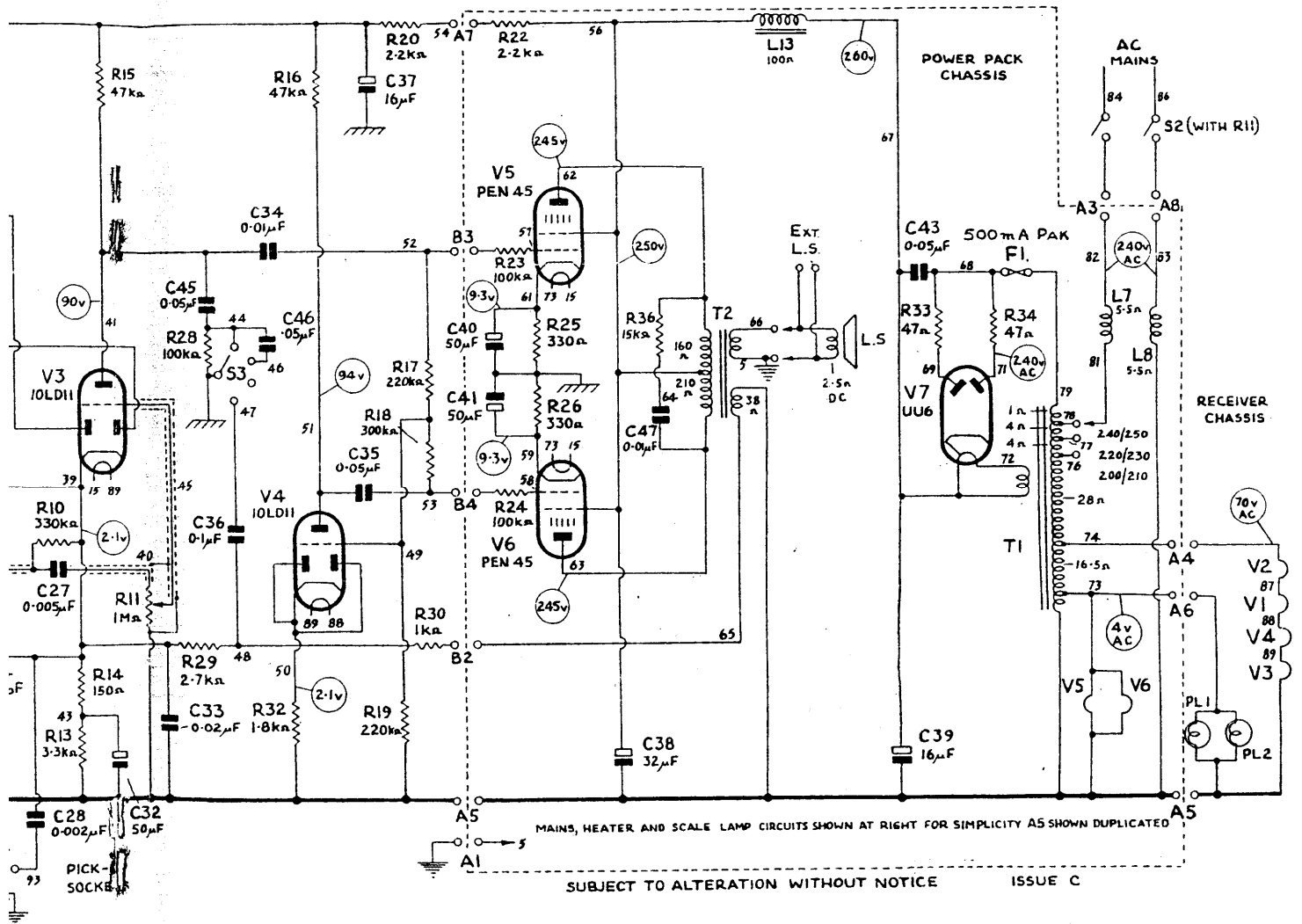

Fig. 8

A 500 ohm/volt meter was used for taking the voltage readings; the receiver was switched to the medium wave band and operating under "no signal" conditions. In those cases where the resistance of a coil is omitted, the value is less than one ohm. The wave range switch is shown in the long wave position.

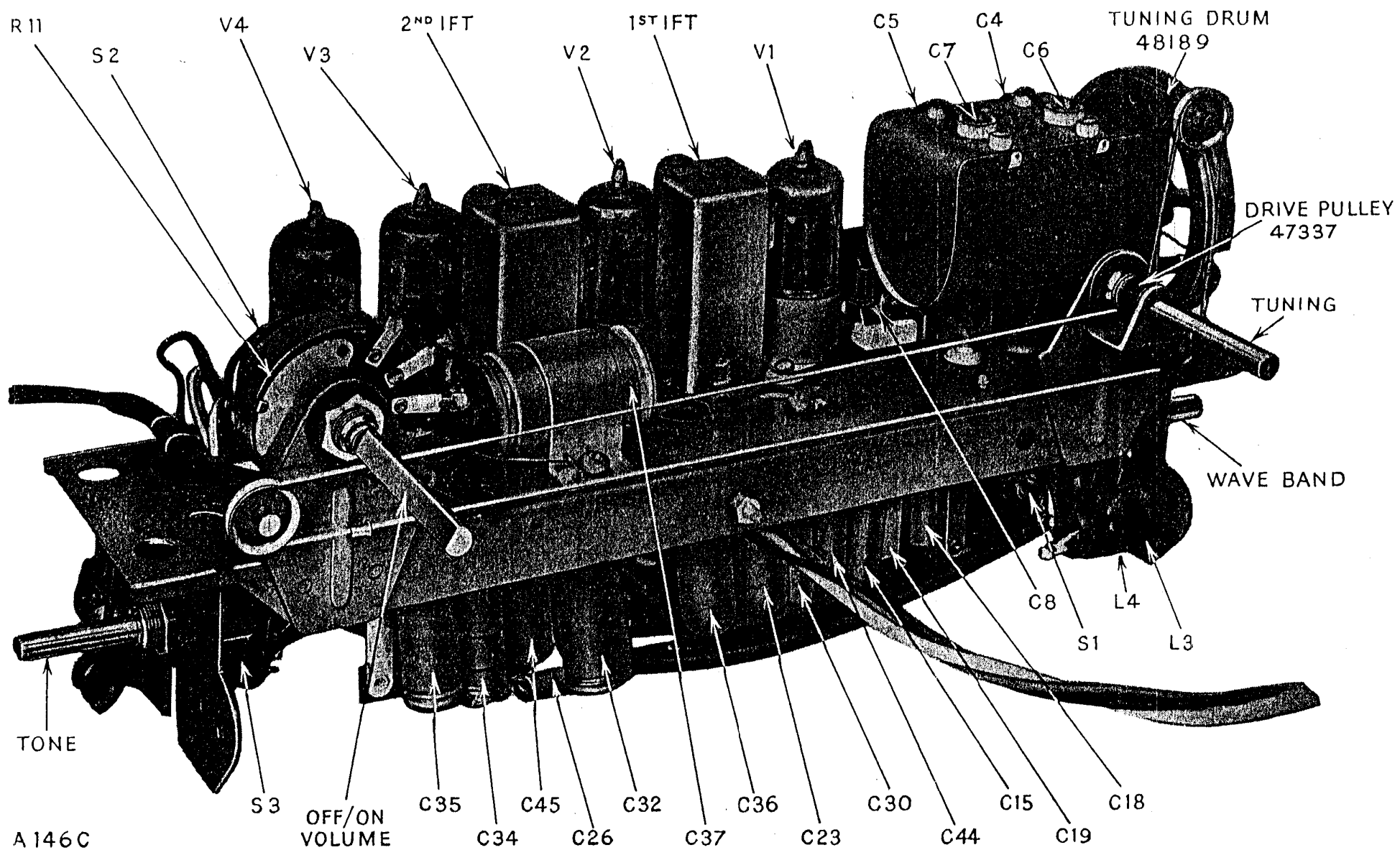

Fig. 9. Top view of the receiver chassis. The underneath view is on page 6.

C				21 20 37	14 13	8	5 7 6 4		C
L				12 11	10 9		5 6		L
R		11							R
MISC.	S2 V4	V3 PL1		V2		V1 PL2			MISC.

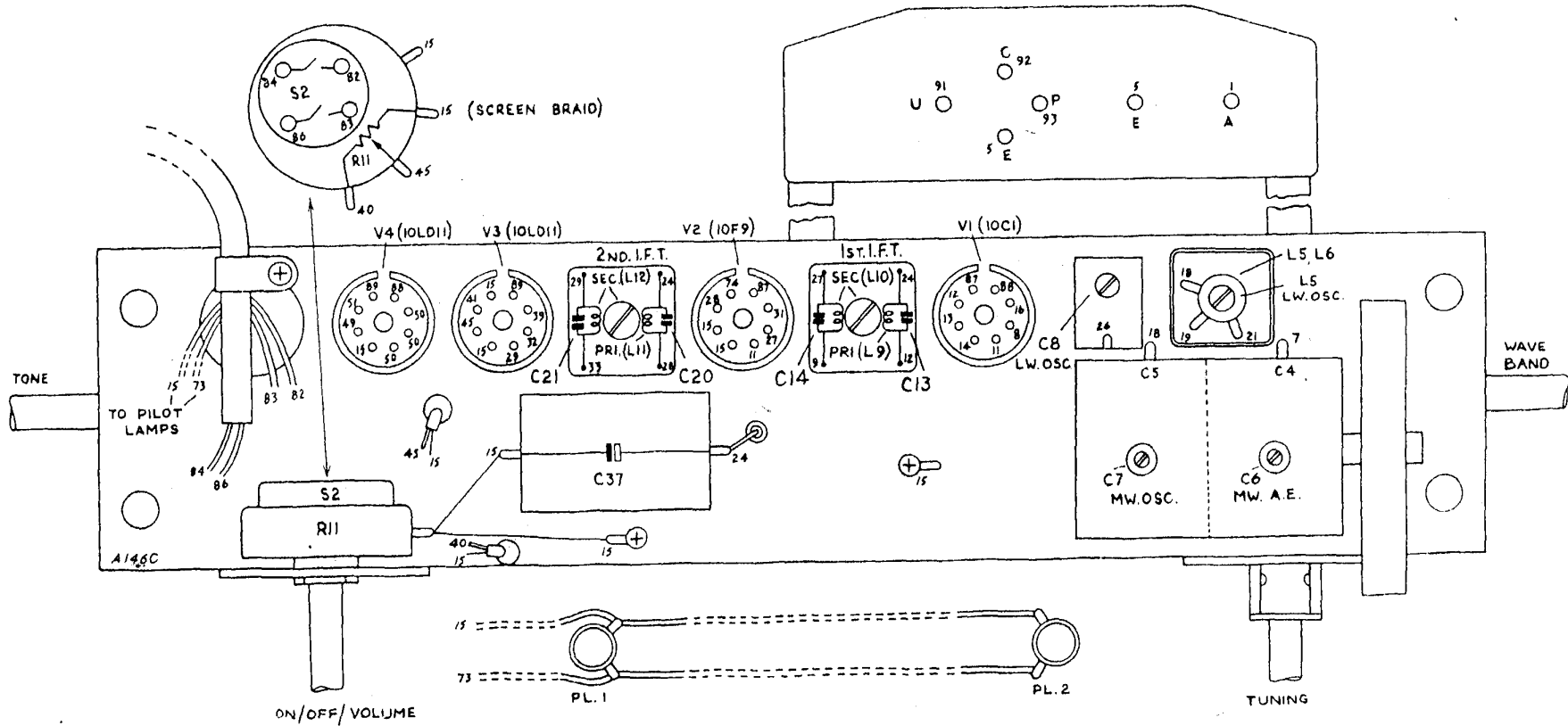

Fig. 10. Diagram of the top of the receiver chassis. The diagram of the underneath of the receiver chassis is on page 8.

C							38 39			C
L					7 8		13			L
R										R
MISC.	T.2.		V5 V6	V7		F.I.			T.I.	MISC.

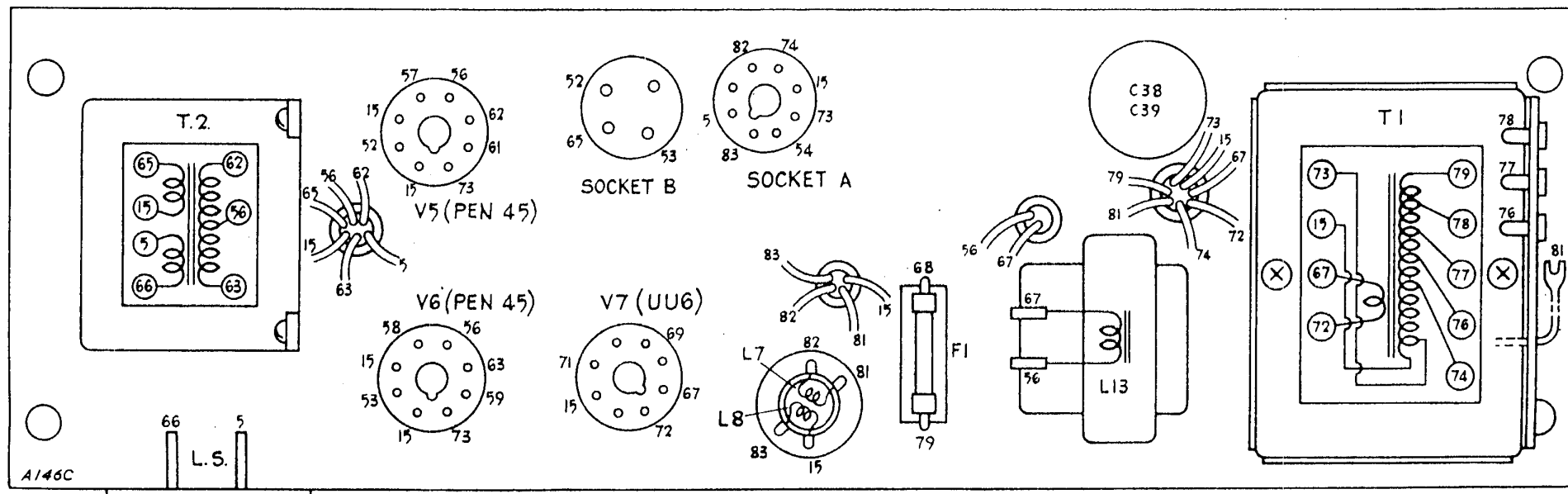

Fig. 11. Diagram of the top of the power unit. The diagram of the underside of the power unit is opposite.
 Note: For Socket A, read Plug A.

C	41 40			47				38 39 43		C
L										L
R		23 24		25 26 36	33 34 22					R
MISC.			V5 V6		V7	F1				MISC.

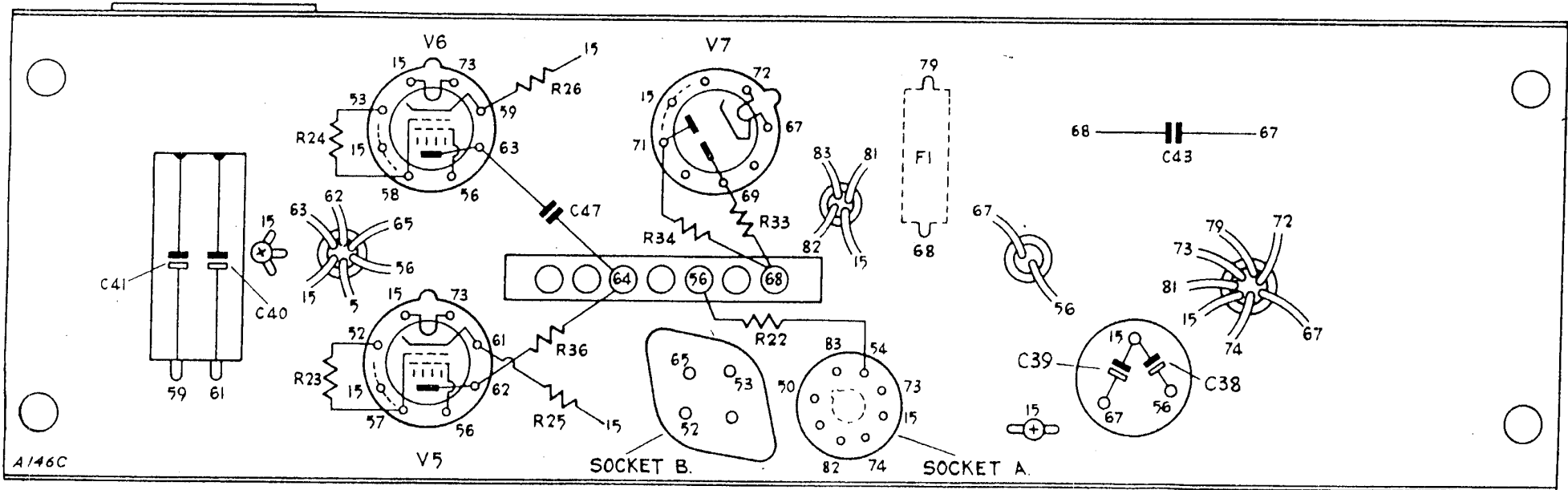

Fig. 12. Diagram of the underside of the power unit. The diagram of the top of the power unit is opposite.

Note: For Socket A, read Plug A.

MODIFICATIONS

Component lay-out. The mechanical disposition of the components was slightly modified in later receivers.

I.f. feedback and whistles. C33 was not fitted in some early receivers. It reduces certain whistles caused by i.f. feedback when the receiver is tuned to stations operating on frequencies which are harmonics or sub-harmonics of the i.f.

The i.f.t. cans. These were increased in length in later receivers. In case a replacement can or assembly is required, the correct length of can should be quoted when ordering. A long can will foul the back in an early receiver and may cause the "live" chassis to be exposed.

Hum with gramophone pick-up. C31 was changed to $0.01 \mu\text{F}$. in later receivers to reduce hum.

Distortion with gramophone pick-up. A $6.8 \text{ M}\Omega$ resistor (R38) is connected between the P and U gramophone pick-up sockets in later receivers to provide a leakage path for the electrostatic charge which may build up across the crystal. This charge tends to bend the crystal (piezo-electric effect) causing it to operate on a non-linear portion of its characteristic, resulting in distorted reproduction, and loss of bass.

To use a magnetic type gramophone pick-up. The gramophone circuits can be modified if required for use with the E.M.I. record player, or any other record player fitted with a similar type of pick-up and having a speech coil impedance of 1 to 5 ohms.

This modification entails the replacement of the existing pick-up input circuit by a pick-up transformer and a modification to the feedback circuit to provide bass compensation. In playing desks already incorporating a pick-up transformer, this component must be disconnected and the pick-up leads brought out for direct connection to the transformer which is mounted in the receiver.

This circuit cannot be adapted for pick-ups of higher impedance.

Parts required.

- 1—Assembly of pick-up transformer (Part No. 50904).
- 1—Insulated screened lead 6 in. long.
- 1—Resistor $10 \text{ K}\Omega \pm 20$ per cent $\frac{1}{4}$ W. (Part No. 27077).
- 1—Capacitor $0.05 \mu\text{F}$. ± 20 per cent 350 v. (Part No. 41403).
- 1—Capacitor $0.005 \mu\text{F}$. ± 25 per cent 500 v. (Part No. 41409).
- Tinned copper wire, 23 SWG.
- 14/36 V.I.R. flex.
- 1/22 V.I.R. single wire.
- 1 m.m. sleeving.
- 2—Brackets (Part No. 37588).

2— $\frac{1}{2}$ in. 6 BA. bolts.

2—6 BA. nuts.

2—6 BA. spring washers.

The above items can be had as a kit from Murphy Radio Ltd, Service Department.

The circuit changes. In the following notes, tag numbers on the R/C rack have been counted from the wave-band switch end of the chassis. The word "lower" refers to the tag strip close to the chassis; "upper" to the tag strip remote from the chassis. *It is important to remember that these tag numbers do not correspond with the test point numbers in the diagram of the underside of the receiver chassis on page 8.*

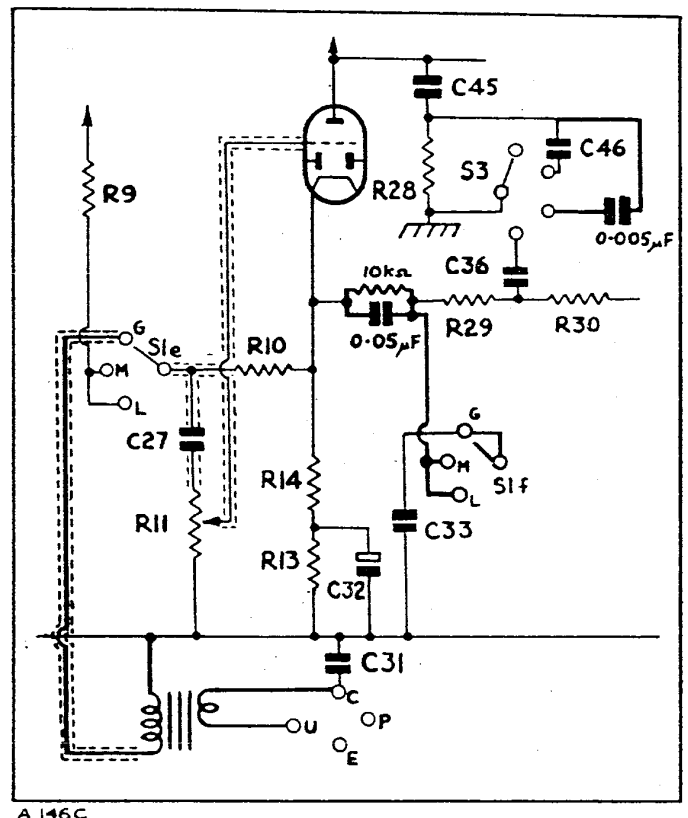

A 146C

Fig. 13

1. Remove the receiver chassis from the cabinet.
2. Remove C28, $0.002 \mu\text{F}$. (P.U. socket "P" to tag 5 upper), and C29, $0.002 \mu\text{F}$. (P.U. socket "U" to tag 7 upper).
3. Remove C30, 220 pF. (tag 7 upper to tag 7 lower), R12, $330 \text{ K}\Omega$ (tag 7 lower to tag 5 lower), and R35, $2.2 \text{ M}\Omega$ (tag 7 upper to tag 5 lower).
4. Connect in parallel a $10 \text{ K}\Omega \frac{1}{4}$ W. resistor and a $0.05 \mu\text{F}$. 350 v.w. capacitor across tag 7 upper and tag 7 lower.

5. Disconnect R29, 2.7 KΩ, from tag 15 upper and connect this end of the resistor to tag 7 upper.
6. Connect tag 7 lower to tag 5 upper.
7. All contacts at the left-hand side of the front wafer of the wave-range switch are connected together. Cut out the centre wire so that the switch is now grouped into two pairs. Connect a wire from the lower (MW/LW) pair of contacts to tag 7 upper.
8. Connect an insulated screened lead 6 in. long to the gram contact of S1e (rear wafer, test point 36). Note that the screening is later connected to the pick-up transformer but not to the receiver.
9. Connect a single piece of V.I.R. flex (4½ in.) to the chassis tag under the aerial panel fixing bracket.
10. Connect twisted flex (6½ in.) to the pick-up sockets "U" (test point 91) and "C" (test point 92).
11. Connect a 0.005 μF. capacitor between the blank tag on the tone control switch and tag 17 lower.

nect the pick-up leads to the braid and centre conductor of the output screened lead. The braid must be insulated from the motor frame.

The oscillator circuit. This was modified in later receivers to increase the medium wave band coverage at the high frequency end and to reduce inter-action between the medium and long wave sections of the oscillator coil during circuit alignment. The revised circuit and wiring are illustrated in Fig. 15 and Fig. 16 respectively. A tuned grid arrangement with separate coupling coil has been adopted for both wavebands.

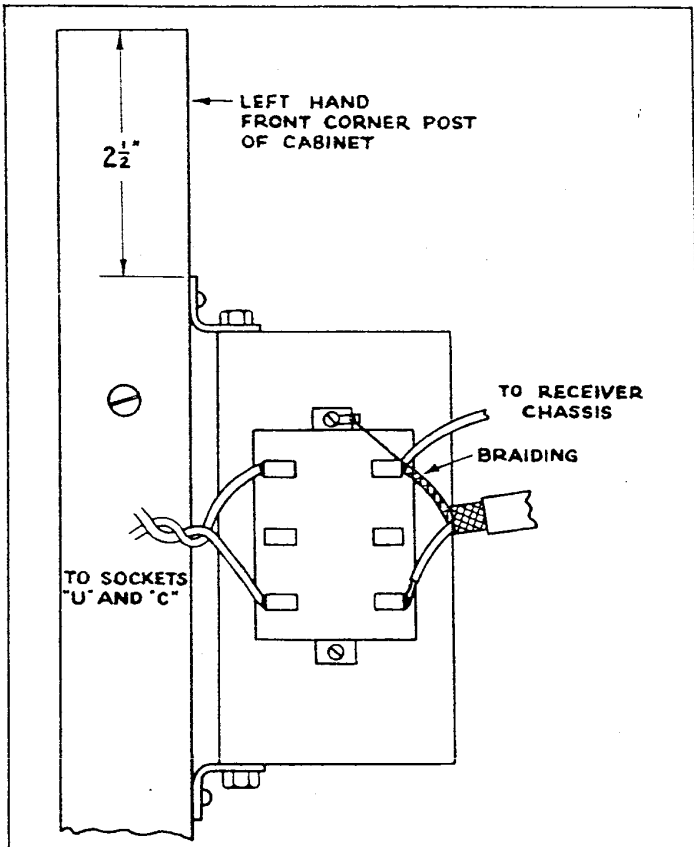

Fig. 14

12. Screw the pick-up transformer and bracket to the left-hand front corner post of the cabinet. The top edge of the bracket should be 2½ in. from the top of the corner post.
13. Replace the receiver chassis and solder the connections to the transformer as shown in Fig. 14.

The modified circuit is shown in Fig. 13.

Modifications required in the E.M.I. record player. Disconnect the pick-up leads and the output screened lead from the transformer and from the motor frame. Con-

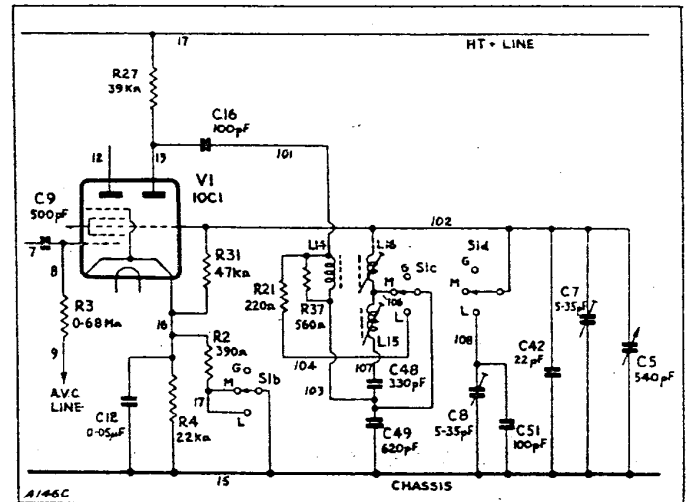

Fig. 15

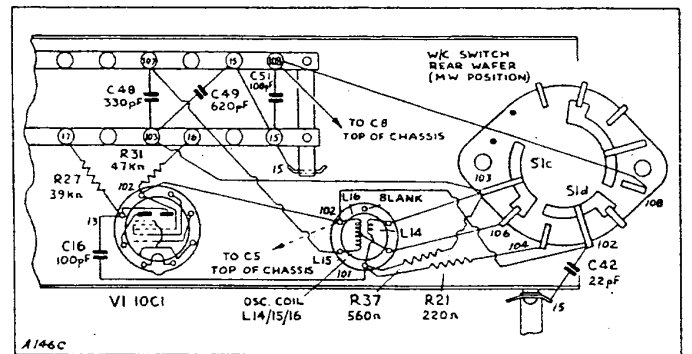

Fig. 16

PART NO.	CIRCUIT NO.	VALUE	TOLERANCE AND REMARKS
23603	C42	22pF.	10% p.s.m.
28165	C48	330pF.	2% p.s.m.
28241	C49	620pF.	1% p.s.m.
28156	C51	100pF.	5% p.s.m.
24677	R21	220Ω	10% ¼W.
24837	R37	560Ω	10% ¼W.
54832	L14	—	Modified osc. coil
	L15		
	L16		

The modified receivers are most easily recognized by a red spot painted on the oscillator coil screen. The oscillator coil itself is recognizable because it has six tags. In the unmodified sets the red paint spot is missing and the oscillator coil has only three tags.

With an earlier receiver if difficulty is experienced in tuning down to 194 metres, it may be necessary to change to the new circuit arrangement, in which case

the items listed below figure 16 will be required.

In carrying out the modification C15, C17, C18, C19, R5, and the original oscillator coil (L5, L6), are completely removed, while R31 (the oscillator grid leak) and R27 are repositioned on the chassis as shown in Fig. 16.

It should be noted that the medium wave and long wave windings and cores on the new coil are transposed as compared with the original coil.

AERIAL FILTERS

When a receiver is installed close to a powerful medium wave transmitter, an aerial filter may be required to prevent overloading of the frequency changer and to minimize the generation of whistles during reception of the weaker stations.

The following approximate figures may be helpful in deciding if a filter will be required at any particular site.

Transmitter Power (KW)	1	2	10	60	100
Fit filter when distance is					
less than (miles)	1½	2	3¼	7	9

Three standard filters are available from Murphy Radio Ltd, Service Department, as follows:

Type	Frequency Range
A	1500-1000 Kc/s (200-300 metres)
B	1000-700 Kc/s (300-428 metres)
C	700-500 Kc/s (428-600 metres)

These may be supplied in single units, or the following double units: AA; BB; CC; AB; AC; and BC.

Fitting instructions. The position of the filter is shown in the photograph of the rear of the receiver on page 2. Screw the bracket on to the cross bar, using the two holes provided, with the filter core uppermost. The lead from the filter is plugged into the receiver aerial socket and the aerial is plugged into the filter; a hole is provided in the receiver back to allow for this.

Adjusting the filter. Connect a voltmeter between the cathode of V2 and chassis, and switch to the 5 or 10 V. d.c. range. Tune the receiver to the interfering (local) station and adjust the filter core for maximum meter reading.

PARTS LIST (Electrical Components)

All resistors are rated at ¼ watt and all types of capacitors are of positive temperature coefficient and rated at 350 v.w., unless otherwise stated. The d.c. resistance quoted for the coil and transformer windings is an average figure and should be used as a general guide only; it is omitted where the value is less than one ohm. The coils are supplied without cans or cores, unless otherwise stated.

The following abbreviations are used in the table below:

-ve	—	negative temperature coefficient	s.tub.	—	sealed paper tubular
cer.	—	ceramicon	tub.	—	paper tubular
elec.	—	electrolytic	v.w.	—	d.c. voltage working
i.s.tub.	—	insulated sealed paper tubular	W.	—	wattage rating.
m.tub.	—	metallized paper tubular	w.w.	—	wire wound.
p.s.m.	—	protected silvered mica.			

PART NO.	CIRCUIT NO.	VALUE	TOLERANCE AND REMARKS	PART NO.	CIRCUIT NO.	VALUE	TOLERANCE AND REMARKS
53924	C1	470pF.	20% 500 v.w., cer	41403	C45	0.05μF.	20% tub.
27986/5	C2	500pF.	10% m.m.	41403	C46	0.05μF.	20% tub.
28251	C3	75pF.	5% p.s.m.	41419	C47	0.01μF.	25% 1000 v.w. tub.
52302	C4	540pF.	Gang capacitor (ae.)	28165	C48	330pF.	2% p.s.m.
	C5	540pF.	Gang capacitor (osc.)	28241	C49	620pF.	1% p.s.m.
	C6	5-35pF.	Trimmer (m.w. ae.)	28156	C51	100pF.	5% p.s.m.
	C7	5-35pF.	Trimmer (m.w. osc.)				
	C8	5-35pF.	Trimmer (l.w. osc.)				
37480	C9	500pF.	20% m.m.	25389	R1	15KΩ	10% 1/2W.
23966	C10	0.01μF.	25% tub.	24773	R2	390 Ω	10%
47449	C11	0.01μF.	25% 1000 v.w. tub.	27429	R3	680KΩ	20%
41419	C12	0.05μF.	20% tub.	27141	R4	22KΩ	20%
41403	C13	100pF.	5% p.s.m.	25677	R5	82KΩ	10% 1/2W.
52630	C14	100pF.	5% p.s.m.	24773	R6	390 Ω	10%
52630	C15	100pF.	20% cer.	27429	R7	680KΩ	20%
52178	C16	100pF.	20% cer.	27493	R8	1.5MΩ	20%
52178	C17	470pF.	2% p.s.m.	27365	R9	330KΩ	20%
28243	C18	150pF.	1% p.s.m.	27365	R10	330KΩ	20%
28253	C19	390pF.	5% p.s.m.	52773	R11	1MΩ	Volume control
28205	C20	100pF.	5% p.s.m.	27365	R12	330KΩ	20%
52630	C21	100pF.	5% p.s.m.	25125	R13	3.3KΩ	10%
52630	C22	0.05μF.	20% tub.	24613	R14	150 Ω	10%
41403	C23	0.05μF.	20% tub.	27205	R15	47KΩ	20%
41403	C24	56pF.	20% cer.	25573	R16	47KΩ	10%
52174	C25	100pF.	20% cer.	29110	R17	220KΩ	5% high stability
52178	C26	100pF.	20% cer.	29111	R18	300KΩ	5% high stability
52178	C27	0.005μF.	25% 500 v.w. tub.	25829	R19	220KΩ	10%
41409	C28	0.002μF.	25% 1000 v.w. tub.	R20	2.2KΩ	10% 1W.	
41417	C29	0.002μF.	25% 1000 v.w. tub.	24677	R21	220 Ω	10%
23637	C30	220pF.	10% p.s.m.	25084	R22	2.2KΩ	10% 1W.
41419	C31	0.01μF.	25% 1000 v.w. tub.	27269	R23	100KΩ	20%
31316	C32	50μF.	+100% -20% 12 v.w. elec.	27269	R24	100KΩ	20%
41402	C33	0.02μF.	20% tub.	24749	R25	330 Ω	10% 1/2W.
50964	C34	0.01μF.	25% 500 v.w. s.tub.	24749	R26	330 Ω	10% 1/2W.
48284	C35	0.05μF.	20% 500 v.w. s.tub.	25541	R27	39KΩ	10%
41404	C36	0.1μF.	20% tub.	27269	R28	100KΩ	20%
46534	C37	16μF.	+50% -20% 450 v.w. elec.	25093	R29	2.7KΩ	10%
46536	C38	32μF.	+50% -20% elec.	24933	R30	1KΩ	10%
	C39	16μF.		27205	R31	47KΩ	20%
46531	C40	50μF.	+50% -20% 25 v.w. elec.	25029	R32	1.8KΩ	10%
	C41	50μF.		24444	R33	47 Ω	10% 1W.
23603	C42	22pF.	10% p.s.m.	24444	R34	47 Ω	10% 1W.
41421	C43	0.05μF.	20% 1000 v.w. tub.	27525	R35	2.2MΩ	20%
23637	C44	220pF.	10% p.s.m.	25404	R36	15KΩ	10% 1W.
				24837	R37	560 Ω	10%
				27622	R38	6.8MΩ	20%

PART NO.	CIRCUIT NO.	RESISTANCE (d.c.)	REMARKS	PART NO.	CIRCUIT NO.	RESISTANCE (d.c.)	REMARKS
52301	L1	—	m.w. aerial coil	52219	L11	17Ω	2nd i.f.t. with can (see Modifications)
	L2	2.2Ω		52219	L12	17Ω	
52300	L3	33Ω	l.w. aerial coil	52272	L13	100Ω	L.f. choke
	L4	23Ω		54832	L14	—	
54388	L5	3Ω	m.w./l.w. osc. coil with core (original)	54832	L15	11.5Ω	m.w./l.w. osc. coil with core (modified)
	L6	1.5Ω		54832	L16	4.5Ω	
49044	L7	5.5Ω	Mains filter	52271	T1	53Ω	Total auto wdgs. } m.t. Sec.
	L8	5.5Ω		52270	T2	—	
52219	L9	17Ω	1st i.f.t. with can (see Modifications)	52270	T2	160+210Ω	Pri. } o.t. L.s. sec. } F.b. sec. }
	L10	17Ω		52270	T2	38Ω	

PARTS LIST (Mechanical Components)

This list contains only those parts which are not included in the Electrical Parts List; items such as self-tapping screws, bolts and nuts, etc. may be obtained from Murphy Radio Ltd, Service Department. Where more than one item is used per receiver, the quantity is given in brackets after the description.

PART NO.	DESCRIPTION	REMARKS	PART NO.	DESCRIPTION	REMARKS
52280	Back	for cabinet	48438	Panel, loudspeaker	on power unit
52624	Bearing (2)	for controls	53601	Panel, mains tapping	
57341	Bracket, mounting (6)	for back	37974	Plug, aerial	
52288	Bracket, mounting	for gang capacitor	37975	Plug, earth	
38576	Buffer, rubber (2)	for cabinet	50096	Plug (2)	for L.S.
52298	Cabinet	complete	49301	Plug, 4 pin	for chassis intercon-
54393	Carrier	for pointer	52264	Plug, 8 pin	necting
32240	Clamp (2)	for mains lead	51634	Pointer	for chassis intercon-
37385	Clip (3)	for leads	49593	Pulley (3)	necting
52291	Clip, retaining (2)	for scale	54251	Ring, mounting	for cord drive
52291	Clip, retaining	for osc. coil former	55561	Scale	for loudspeaker
41613	Clip, spring (3)	for leads	52366	Screen	printed
40134	Contact	for mains tapping panel	704041	Screw, self-tapping	for osc. coil
40135	Contact, spade	for mains adjustment	102405	Screw, wood (4)	for mains tapping panel
Spec. 936	Cord for drive	40 in. length	52281	Skirt (2)	for securing loud-
52623	Cover, presspahn	for gang capacitor	52265	Socket, 8 pin	speaker
47337	Drive pulley	for tuning spindle	37390	Socket (6)	for tuning knob
48189	Drum tuning	for gang capacitor	1829/10	Speaker fabric	for chassis intercon-
15628	Eyelet	for drive cord	15264	Speednut (2)	necting
52113	Fuse, PAK 500 mA.		52290	Spindle, tuning	for AE, E, and PU
8608	Grommet (6)	for chassis mounting	54158	Spring (2)	panel
42842	Grommet (2)	for lampholders	47478	Spring	11 in. by 11 in.
8589	Grommet (6)	for V1, V3, V4 mount-	48193	Strap, fixing (2)	for retaining aerial
50040	Guide rail	ing	52276	Support (2)	coils
48701	Holder	for pointer carrier	52289	Switch	scale retaining
50045	Holder	for fuse	51451	Valveholder B8A (4)	for drive cord
53555	Knob, tone	engraved	3975	Valveholder BO (3)	for mains filter
52278	Knob, plain (2)	for tuning or volume	49300	Valveholder 4 pin	for scale
53044	Knob, wave-band	engraved	50042	Washer, cup shaped	for wave band
16880	Lamp, pilot (2)	6.2 volt 0.3 amp.	47940	(12)	for chassis mounting
52323	Lampholder (2)	Philips	14983	Washer (3)	for gang mounting
52243	Loudspeaker	for pilot lamps	52624	Washer (4)	for securing loud-
53684	Nut OBA cropped (2)	for chassis fixing	34592	Washer, felt (2)	speaker
53606	Panel, AE, E, and PU			Washer, felt (2)	for control spindles
					for front control knobs