

ICF-SW20

SERVICE MANUAL

US Model
 Canadian Model
 AEP Model
 UK Model
 E Model



SPECIFICATIONS

Frequency range	FM: 76 – 108 MHz (US, Canadian, E model) 87.6 – 107.5 MHz (AEP, UK, Italian, Saudi Arabia model)
	IF: 10.7 MHz
	SW1: 5.775–6.425 MHz
	SW2: 6.875–7.525 MHz
	SW3: 9.375–10.025 MHz
	SW4: 11.615–12.265 MHz
	SW5: 15.00–15.65 MHz
	SW6: 17.50–18.15 MHz
	SW7: 21.325–21.975 MHz
	1st IF: 10.7 ± 0.35 MHz
	2nd IF: 455 kHz
	MW: 530 – 1710 kHz (US, Canadian, E model) 531 – 1602 kHz (AEP, UK, Italian, Saudi Arabia model)
	IF: 455 kHz
Antenna	FM/SW: telescopic antenna MW: built-in ferrite bar antenna
Speaker	Approx. 4.4 × 4.4 cm (1 3/4 × 1 3/4 inches) 8 Ω
Power output	100 mW (at 10% harmonic distortion) 200 mW (maximum output)
Output	Earphone jack (minijack)
Power requirements	3 V DC, two R6 (size AA) batteries.
Battery life	Approx. 22 hours with Sony SUM-3 (NS)
Dimensions	Approx. 116.5 × 72.5 × 28 mm (w/h/d) (4 1/2 × 2 7/8 × 1 1/8 inches)
Weight	Approx. 203 g (7.2 oz) incl. batteries
Accessories supplied	Earphone (1), Carrying case (1), Short wave guide (1)

Design and specifications subject to change without notice.

Features

- Handy FM/MW/SW1-7 9 band receiver with high sensitivity and selectivity.
- Band spread system enables you to easily tune in SW stations.
- Dual conversion circuit effectively reduces SW bands interference from other SW stations.

Parts Identification

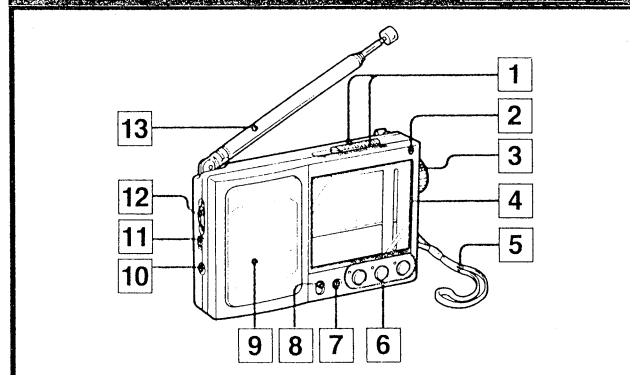

- | | |
|--|--|
| 1 SW BAND selector | 8 HOLD switch |
| 2 TUNE (tuning indicator) | Set it to the direction of the arrow: |
| The indicator lights up when signal is received. | When listening, to avoid accidental change of the functions. |
| 3 TUNING control | When not using, to prevent accidental pressing to turn the power on. |
| 4 Dial scales | 9 Speaker |
| 5 Hand strap | 10 Ⓞ (earphone) jack |
| 6 Band selectors and indicators (FM/MW/SW) | 11 TONE (MUSIC/NEWS) selector |
| The unit turned on with the band selectors. | MUSIC: for listening to the music |
| 7 OFF (power off) button | NEWS: for listening to news, etc. |
| | 12 VOLUME control |
| | 13 Telescopic antenna |

FM/MW/SW1-7
 9 BAND RECEIVER

SONY®



SECTION 1 DISASSEMBLY

FRONT AND REAR CABINET

Note: Follow the disassembly procedure in the numerical order given.

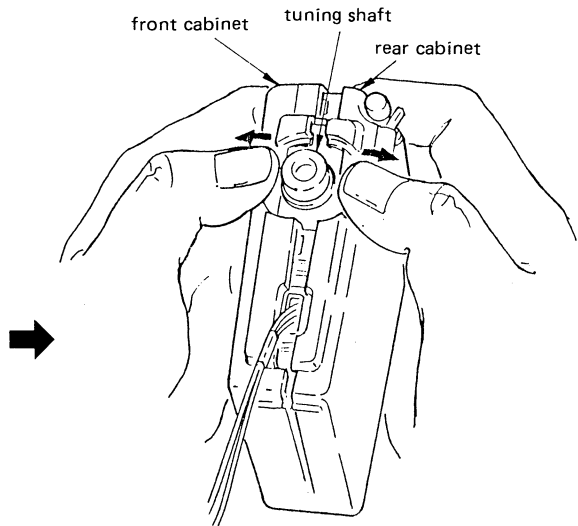
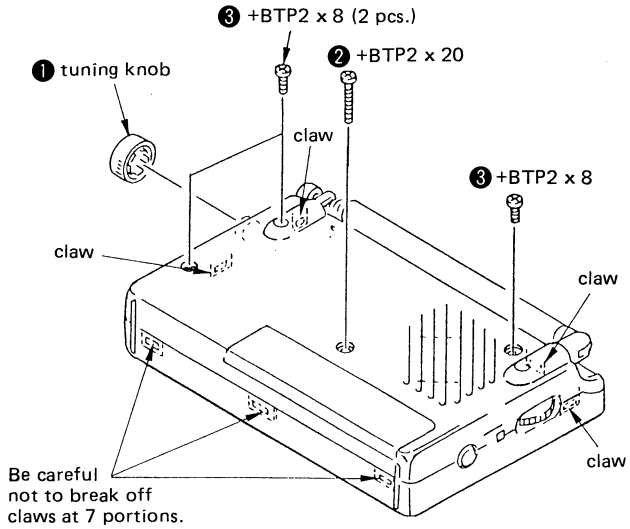

DIAL POINTER SETTING

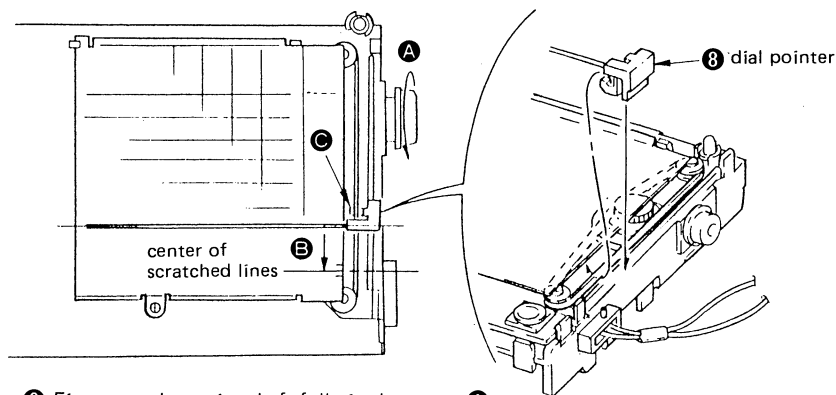
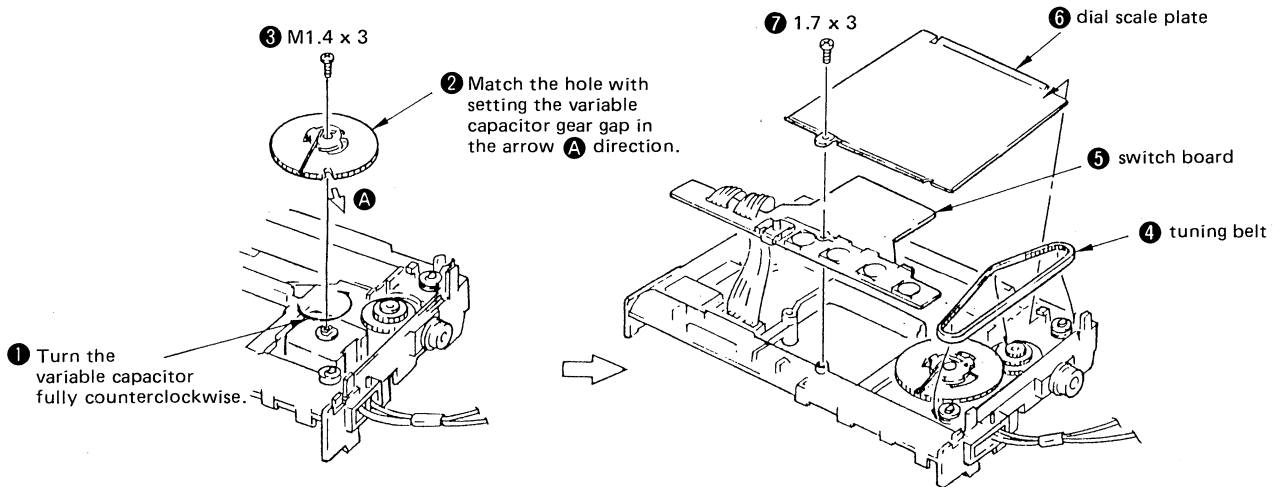

⑨ First, turn the tuning shaft fully in the arrow A direction. Move only the dial pointer in the arrow B direction and set it on the center of the scratched lines on the dial scale plate. Apply suitable locking compound to C portion.

SECTION 2 ELECTRICAL ADJUSTMENTS

[MW SECTION]

BAND switch: MW

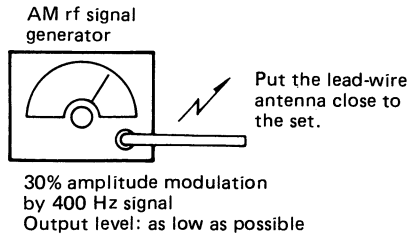

[SW SECTION]

BAND switch: SW

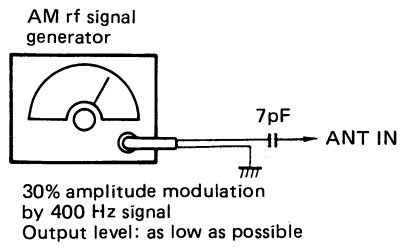

[FM SECTION]

BAND switch: FM

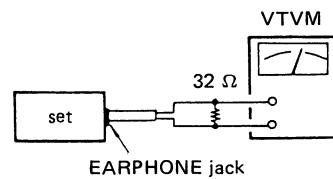
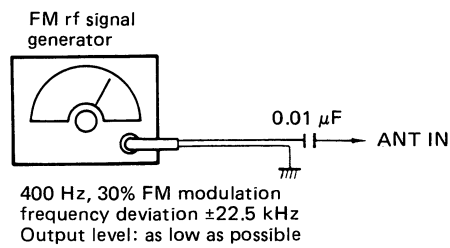

- Repeat the procedures in each adjustment several times, and the frequency coverage and tracking adjustments should be finally done by the trimmer capacitors.
- SW1 to 7 Tracking Adjustment frequencies are in a line on the scale. Therefore, on adjusting, first SW1 6.1 MHz and after adjust SW2 to 7 Tracking without moving the dial pointer.

() : AEP, UK, Saudi Arabian model

MW IF ADJUSTMENT	
Adjust for a maximum reading on VTVM.	
T2	455 kHz

MW FREQUENCY COVERAGE ADJUSTMENT	
Adjust for a maximum reading on VTVM.	
L17	520 kHz
CT11-3	1,750 kHz (1,650 kHz)

MW TRACKING ADJUSTMENT	
Adjust for a maximum reading on VTVM.	
L14	620 kHz
CT11-4	1,400 kHz

SW IF (1) ADJUSTMENT	
Adjust for a maximum reading on VTVM.	
T1	10.6 MHz

SW IF (2) ADJUSTMENT	
Adjust for a maximum reading on VTVM.	
T3	455 kHz

SW1 FREQUENCY COVERAGE ADJUSTMENT	
Adjust for a maximum reading on VTVM.	
T4	5.75 MHz
CT1	6.45 MHz

SW1 TRACKING ADJUSTMENT	
Adjust for a maximum reading on VTVM.	
L1	6.1 MHz

SW2 TRACKING ADJUSTMENT	
Adjust for a maximum reading on VTVM.	
L2	7.2 MHz

SW3 TRACKING ADJUSTMENT	
Adjust for a maximum reading on VTVM.	
L3	9.7 MHz

SW4 TRACKING ADJUSTMENT	
Adjust for a maximum reading on VTVM.	
L4	11.94 MHz

SW5 TRACKING ADJUSTMENT	
Adjust for a maximum reading on VTVM.	
L5	15.325 MHz

SW6 TRACKING ADJUSTMENT	
Adjust for a maximum reading on VTVM.	
L6	17.825 MHz

SW7 TRACKING ADJUSTMENT	
Adjust for a maximum reading on VTVM.	
L7	21.65 MHz

FM FREQUENCY COVERAGE ADJUSTMENT	
Adjust for a maximum reading on VTVM.	
L16	75.0 MHz (87.35 MHz)
CT11-2	109.5 MHz (108.05 MHz)

FM TRACKING ADJUSTMENT	
Adjust for a maximum reading on VTVM.	
L15	80 MHz (87.35 MHz)
CT11-1	104 MHz (108.05 MHz)

[PARTS ARRANGEMENT DIAGRAM FOR ADJUSTMENT]

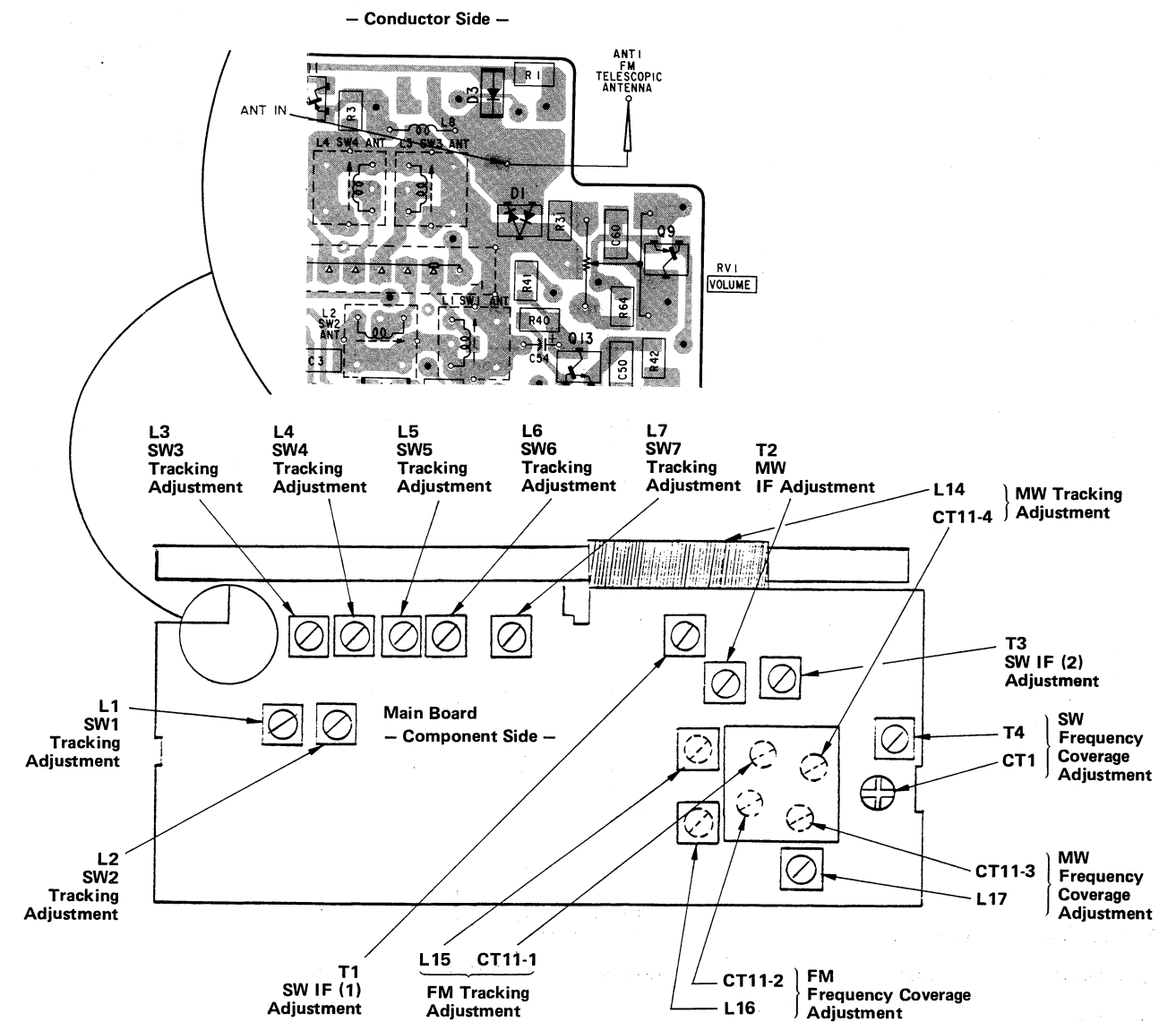

SECTION 3 DIAGRAMS

3-1. PRINTED WIRING BOARDS

Note:

- — : parts extracted from the component side.
- — : parts extracted from the conductor side.
- : parts mounted on the conductor side.
- : Through hole.
- ▨ : Pattern on the side which is seen.
- : Pattern of the rear side.

• IC Block Diagrams

• IC1 CX20091

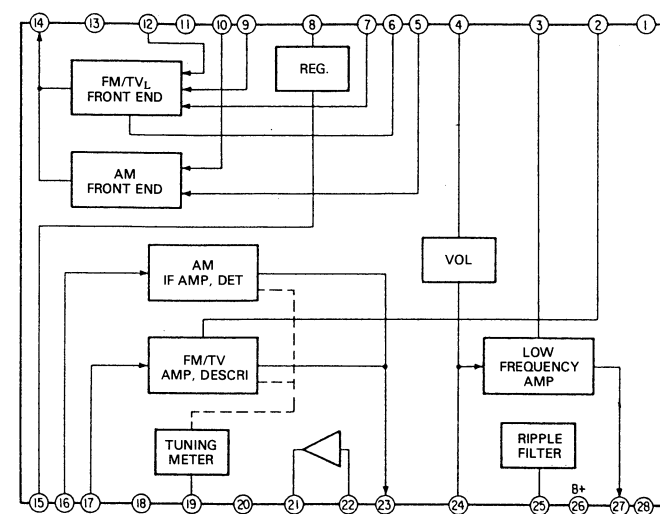

• IC101 CF77392NC

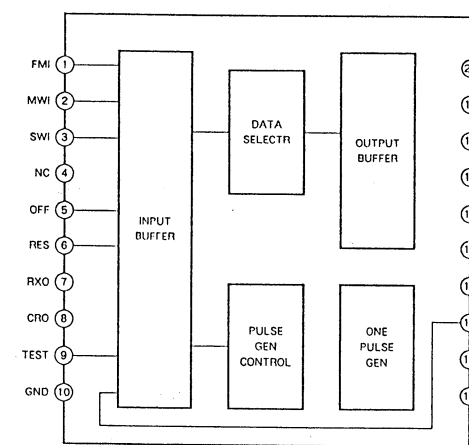

• Semiconductor Location

Ref. No.	Location
D1	B-8
D3	A-8
D4	B-7
D5	C-8
D6	B-3
D8	D-8
D9	A-2
D10	C-9
D11	D-7
D101	F-8
D103	F-7
D104	F-6
IC1	C-5
IC101	H-5
Q1	A-7
Q2	A-5
Q3	A-3
Q4	B-5
Q5	B-2
Q6	C-7
Q7	C-8
Q8	D-2
Q9	B-9
Q10	D-6
Q11	D-7
Q13	C-9
Q14	D-8

• Semiconductor Lead Layouts

CF-77392NS

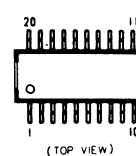

XN4608

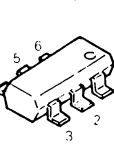

1SS119

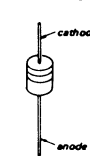

1SS279

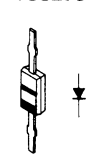

GL1PR111

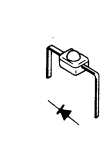

TLR124

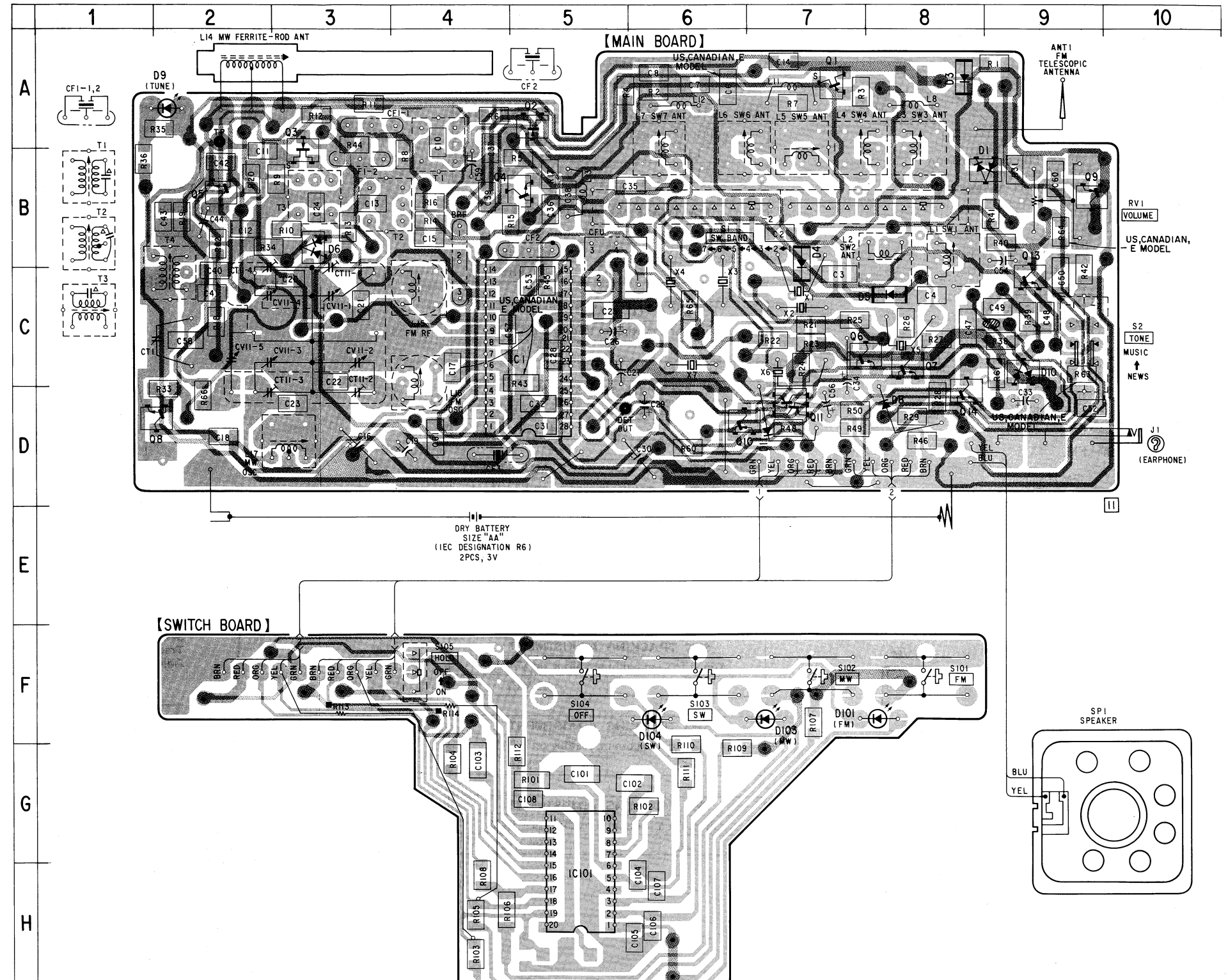
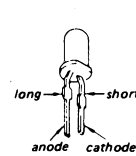

3-2. SCHEMATIC DIAGRAM

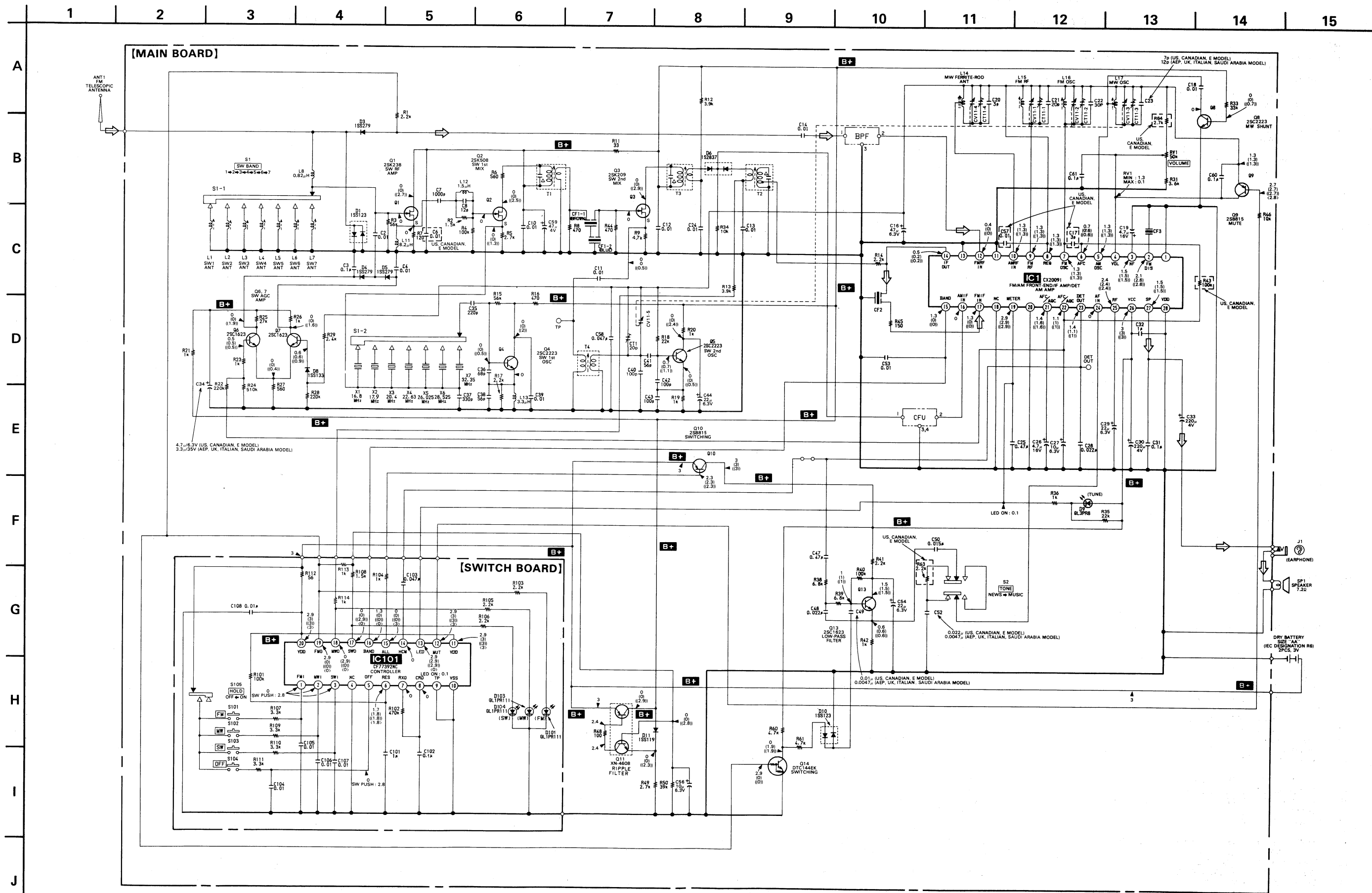

- Note:**
- All capacitors are in μF unless otherwise noted. pF : $\mu\mu\text{F}$. 50WV or less are not indicated except for electrolytics and tantalums.
 - All resistors are in Ω and $\frac{1}{4}\text{W}$ or less unless otherwise specified.
 - Voltage and waveforms are dc with respect to ground under no-signal (detuned) conditions.
 - Voltages are taken with a VOM (50 $\text{k}\Omega/\text{V}$). Voltage variations may be noted due to normal production tolerances.
 - Signal path.
- Legend:
- () : FM
 - () : MW
 - () : SW
 - < : FM
 - > : OFF

SECTION 4 EXPLODED VIEW

NOTE:

- The mechanical parts with no reference number in the exploded views are not supplied.
- The construction parts of an assembled part are indicated with a collation number in the remark column.
- Items marked "*" are not stocked since they are seldom required for routine service. Some delay should be anticipated when ordering these items.

- Due to standardization, parts with part number suffix -XX and -X may be different from the parts specified in the components used on the set.
- Color Indication of Appearance Parts Example:
(RED) ... KNOB, BALANCE (WHITE)

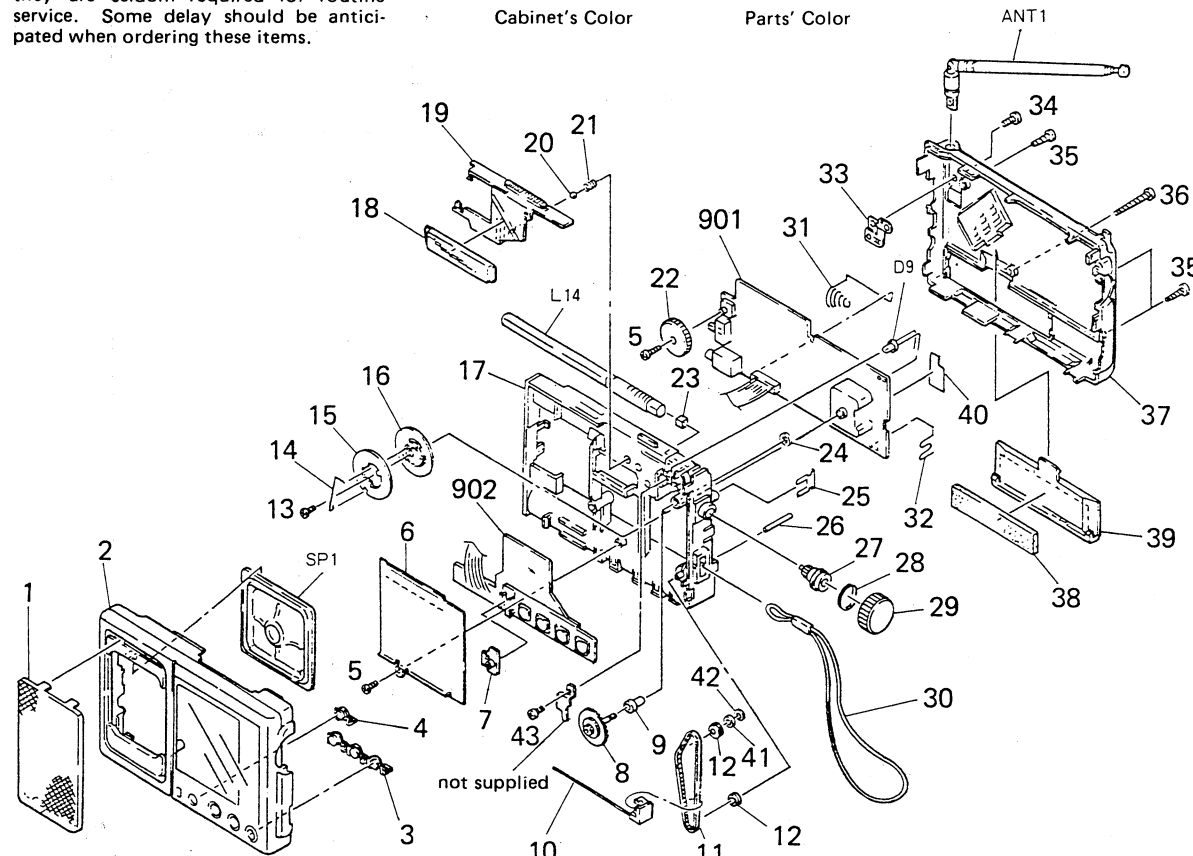
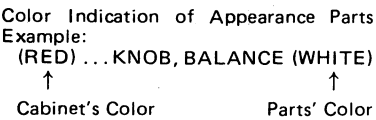

No.	Part No.	Description	Remarks	No.	Part No.	Description	Remarks
1	3-900-140-01	PANEL (SPEAKER)		28	3-900-151-01	SPRING, RING	
2	X-3899-512-1 X-3899-509-1	(US,Canadian,E)...CABINET (FRONT) ASSY (AEP,UK,Italian,Saudi Arabia) ...CABINET (FRONT) ASSY		29	3-900-148-01	KNOB, TUNING	
3	3-900-136-01	BUTTON, BAND SELECTION		30	3-900-158-01	STRAP, HAND	
4	3-900-137-01	BUTTON (OFF)		31	3-900-152-01	SPRING	
5	3-880-990-00	SCREW (1.7X3), FLAT, (+) SPECIAL		32	3-900-153-01	TERMINAL, BATTERY	
6	3-900-155-11	SCALE, DIAL		33	3-900-141-01	PLATE, CONTACT, ANTENNA	
7	3-900-138-01	BUTTON (HOLD)		34	7-621-259-18	SCREW +P 2.6X3	
8	3-900-143-01	GEAR, MIDWAY		35	4-356-741-31 7-685-105-19	(AEP,UK,Italian,Saudi Arabia) ...SCREW, TAPPING (BIND 2X8) (US,Canadian,E) ...SCREW +P 2X8 TYPE2 NON-SLIT	
9	*3-900-154-01	BEARING		36	3-320-919-11 4-356-741-41	(US,Canadian,E).....SCREW (2X20) (AEP,UK,Italian,Saudi Arabia) ...SCREW, TAPPING (BIND 2X20)	
10	3-900-160-01	POINTER		37	3-900-161-01	CABINET (REAR)	
11	3-900-156-01	BELT (TUNING)		38	9-911-815-01	CUSHION (A)	
12	3-900-157-01	PULLEY		39	3-889-802-00	LID, BATTERY CASE	
13	3-892-318-00	SCREW, SMALL		40	X-3899-510-1	(US,Canadian,E)...PLATE (A) ASSY, SHIELD	
14	3-900-146-01	SPRING, DIAL		41	7-723-924-01	WASHER, POLYETHYLENE	
15	3-900-145-01	GEAR (B), TUNING CAPACITOR		42	3-701-441-01	WASHER, POLYETHYLENE	
16	3-900-144-01	GEAR (A), DIAL		43	3-895-823-01	SCREW, TAPPING	
17	*3-900-162-01	CHASSIS		901	*A-3660-851-A *A-3660-856-A	(AEP,UK,Italian,Saudi Arabia) ...MOUNTED PCB, MAIN (US,Canadian,E)...MOUNTED PCB, MAIN	
18	3-900-142-01	PANEL, SW BAND INDICATION		902	*1-630-133-11	PC BOARD, SWITCH	
19	3-900-159-01	KNOB (SW)		ANT1	1-501-432-11	ANTENNA, TELESCOPIC	
20	7-671-113-02	STEAL, BALL 3		D9	8-719-812-41	LED TLRI24	
21	3-893-926-01	SPRING, COMPRESSION		L14	1-402-434-11	ANTENNA, FERRITE-ROD (MW)	
22	3-900-150-01	KNOB, VOL		SP1	1-544-156-11	SPEAKER	
23	9-911-845-XX	CUSHION (A)					
24	3-311-815-11	WASHER, POLYETHYLENE					
25	3-900-149-01	RETAINER					
26	3-669-481-04	PIN (DIA. 1X12), PARALLEL					
27	3-900-147-01	SHAFT, TUNING					

SECTION 5 ELECTRICAL PARTS LIST

NOTE:

- Due to standardization, replacements in the parts list may be different from the parts specified in the diagrams or the components used on the set.
- Items marked "*" are not stocked since they are seldom required for routine service. Some delay should be anticipated when ordering these items.
- If there are two or more same circuits in a set such as a stereophonic machine, only typical circuit parts may be indicated and capacitors and resistors in other same circuits may be omitted.

CAPACITORS:
MF: μ F, PF: μ F.

RESISTORS
• All resistors are in ohms.
• F: nonflammable

COILS
• MMH: mH, UH: μ H

SEMICONDUCTORS
In each case, U: μ , for example:
UA...: μ A..., UPA...: μ PA...,
UPC...: μ PC, UPD...: μ PD...

Ref.No.	Part No.	Description	Ref.No.	Part No.	Description
901	*A-3660-851-A	(AEP,UK,Italian,Saudi Arabia) ...MOUNTED PCB, MAIN	C35	1-163-125-00	CERAMIC CHIP 220PF 10% 50V
	*A-3660-856-A	(US,Canadian,E)...MOUNTED PCB, MAIN	C36	1-163-113-00	CERAMIC CHIP 68PF 5% 50V
902	*1-630-133-11	PC BOARD, SWITCH	C37	1-163-129-00	CERAMIC CHIP 330PF 10% 50V
ANT1	1-501-432-11	ANTENNA, TELESCOPIC	C38	1-163-111-00	CERAMIC CHIP 56PF 5% 50V
BPF	1-235-170-00	(US,Canadian,E)...FILTER, BAND PASS	C39	1-163-021-00	CERAMIC CHIP 0.01MF 10% 50V
BPF	1-235-171-00	(AEP,UK,Italian,Saudi Arabia) ...FILTER, BAND PASS	C40	1-163-117-00	CERAMIC CHIP 100PF 5% 50V
C2	1-163-021-00	CERAMIC CHIP 0.01MF 10% 50V	C41	1-163-111-00	CERAMIC CHIP 56PF 5% 50V
C3	1-163-077-00	CERAMIC CHIP 0.1MF 50V	C42	1-163-117-00	CERAMIC CHIP 100PF 5% 50V
C4	1-163-021-00	CERAMIC CHIP 0.01MF 10% 50V	C43	1-163-117-00	CERAMIC CHIP 100PF 5% 50V
C6	1-163-059-00	(US,Canadian,E) ...CERAMIC CHIP 0.01MF 50V	C44	1-126-153-11	ELECT 22MF 20% 6.3V
C7	1-163-009-11	CERAMIC CHIP 0.001MF 10% 50V	C47	1-162-637-11	CERAMIC CHIP 0.47MF 16V
C8	1-163-095-00	CERAMIC CHIP 12PF 5% 50V	C48	1-163-037-11	CERAMIC CHIP 0.022MF 10% 25V
C10	1-163-021-00	CERAMIC CHIP 0.01MF 10% 50V	C49	1-163-017-00	(AEP,UK,Italian,Saudi Arabia) ...CERAMIC CHIP 0.0047MF 10% 50V
C11	1-163-021-00	CERAMIC CHIP 0.01MF 10% 50V	C49	1-163-021-00	(US,Canadian,E) ...CERAMIC CHIP 0.01MF 10% 50V
C12	1-163-021-00	CERAMIC CHIP 0.01MF 10% 50V	C50	1-163-059-00	CERAMIC CHIP 0.015MF 50V
C13	1-163-021-00	CERAMIC CHIP 0.01MF 10% 50V	C52	1-163-037-11	(US,Canadian,E) ...CERAMIC CHIP 0.022MF 10% 25V
C14	1-163-021-00	CERAMIC CHIP 0.01MF 10% 50V	C52	1-163-017-00	(AEP,UK,Italian,Saudi Arabia) ...CERAMIC CHIP 0.0047MF 10% 50V
C16	1-126-154-11	ELECT 47MF 20% 6.3V	C53	1-163-021-00	CERAMIC CHIP 0.01MF 10% 50V
C17	1-163-086-00	(US,Canadian,E) ...CERAMIC CHIP 3PF 0.25PF 50V	C54	1-126-153-11	ELECT 22MF 20% 6.3V
C18	1-163-021-00	CERAMIC CHIP 0.01MF 10% 50V	C56	1-126-157-11	ELECT 10MF 20% 6.3V
C19	1-126-094-11	ELECT 4.7MF 20% 16V	C57	1-163-021-00	(US,Canadian,E) ...CERAMIC CHIP 0.01MF 10% 50V
C20	1-163-086-00	CERAMIC CHIP 3PF 0.25PF 50V	C58	1-163-075-00	CERAMIC CHIP 0.047MF 10% 25V
C21	1-163-100-00	CERAMIC CHIP 20PF 5% 50V	C59	1-124-432-00	ELECT 47MF 20% 4V
C22	1-163-104-00	CERAMIC CHIP 30PF 5% 50V	C60	1-163-077-00	CERAMIC CHIP 0.1MF 50V
C23	1-163-090-00	(US,Canadian,E) ...CERAMIC CHIP 7PF 0.25PF 50V	C61	1-163-077-00	CERAMIC CHIP 0.1MF 50V
C23	1-163-095-00	(AEP,UK,Italian,Saudi Arabia) ...CERAMIC CHIP 12PF 5% 50V	C101	1-162-638-11	CERAMIC CHIP 1MF 16V
C24	1-163-021-00	CERAMIC CHIP 0.01MF 10% 50V	C102	1-163-077-00	CERAMIC CHIP 0.1MF 50V
C25	1-162-637-11	CERAMIC CHIP 0.47MF 16V	C103	1-163-075-00	CERAMIC CHIP 0.047MF 10% 25V
C26	1-126-094-11	ELECT 4.7MF 20% 16V	C104	1-163-021-00	CERAMIC CHIP 0.01MF 10% 50V
C27	1-126-157-11	ELECT 10MF 20% 6.3V	C105	1-163-021-00	CERAMIC CHIP 0.01MF 10% 50V
C28	1-163-037-11	CERAMIC CHIP 0.022MF 10% 25V	C106	1-163-021-00	CERAMIC CHIP 0.01MF 10% 50V
C29	1-126-153-11	ELECT 22MF 20% 6.3V	C107	1-163-021-00	CERAMIC CHIP 0.01MF 10% 50V
C30	1-124-434-00	ELECT 220MF 20% 4V	C108	1-163-021-00	CERAMIC CHIP 0.01MF 10% 50V
C31	1-163-077-00	CERAMIC CHIP 0.1MF 50V	CF1	1-577-047-11	FILTER, CERAMIC
C32	1-162-638-11	CERAMIC CHIP 1MF 16V	CF2	1-567-097-61	FILTER, CERAMIC
C33	1-124-434-00	ELECT 220MF 20% 4V	CF3	1-567-097-61	FILTER, CERAMIC
C34	1-126-154-11	(US,Canadian,E) ...ELECT 47MF 20% 6.3V	CT1	1-141-227-00	CAP, CERAMIC TRIMMER
C34	1-126-162-11	(AEP,UK,Italian,Saudi Arabia) ...ELECT 3.3MF 20% 35V	D1	8-719-800-76	DIODE 1SS226
			D3	8-719-123-79	DIODE 1SS279
			D4	8-719-123-79	DIODE 1SS279

Ref.No.	Part No.	Description	Ref.No.	Part No.	Description				
D5	8-719-123-79	DIODE 1SS279	R4	1-216-097-00	METAL GLAZE	100K	5%	1/10W	
D6	8-719-100-05	DIODE 1S2837	R5	1-216-059-00	METAL GLAZE	2.7K	5%	1/10W	
D8	8-719-911-19	DIODE 1SS119	R6	1-216-043-00	METAL GLAZE	560	5%	1/10W	
D9	8-719-812-41	LED TLR124	R7	1-216-027-00	METAL GLAZE	120	5%	1/10W	
D10	8-719-800-76	DIODE 1SS226	R8	1-216-041-00	METAL GLAZE	470	5%	1/10W	
D11	8-719-911-19	DIODE 1SS119	R9	1-216-065-00	METAL GLAZE	4.7K	5%	1/10W	
D101	8-719-975-81	LED GL1PR111	R10	1-216-295-00	METAL GLAZE	0	5%	1/10W	
D103	8-719-975-81	LED GL1PR111	R11	1-216-013-00	METAL GLAZE	33	5%	1/10W	
D104	8-719-975-81	LED GL1PR111	R12	1-216-063-00	METAL GLAZE	3.9K	5%	1/10W	
IC1	8-752-009-10	IC CX20091	R13	1-216-063-00	METAL GLAZE	3.9K	5%	1/10W	
IC101	8-759-979-91	IC CF-77392NS	R14	1-216-057-00	METAL GLAZE	2.2K	5%	1/10W	
J1	1-507-562-00	JACK (EARPHONE)	R15	1-216-091-00	METAL GLAZE	56K	5%	1/10W	
L1	1-402-334-11	COIL (ANT)	R16	1-216-041-00	METAL GLAZE	470	5%	1/10W	
L2	1-402-332-11	COIL (ANT)	R17	1-216-057-00	METAL GLAZE	2.2K	5%	1/10W	
L3	1-402-432-11	COIL (ANT)	R18	1-216-081-00	METAL GLAZE	22K	5%	1/10W	
L4	1-402-331-11	COIL (ANT)	R19	1-216-049-00	METAL GLAZE	1K	5%	1/10W	
L5	1-406-261-11	COIL (OSC)	R20	1-216-049-00	METAL GLAZE	1K	5%	1/10W	
L6	1-402-433-11	COIL (ANT)	R21	1-216-049-00	METAL GLAZE	1K	5%	1/10W	
L7	1-402-330-11	COIL (ANT)	R22	1-216-105-00	METAL GLAZE	220K	5%	1/10W	
L8	1-410-360-11	INDUCTOR	R23	1-216-049-00	METAL GLAZE	1K	5%	1/10W	
L11	1-408-408-00	INDUCTOR	R24	1-216-114-00	METAL GLAZE	510K	5%	1/10W	
						0.82UH			
						8.2UH			
L12	1-410-499-41	INDUCTOR	R25	1-216-083-00	METAL GLAZE	27K	5%	1/10W	
L13	1-410-322-11	INDUCTOR	R26	1-216-049-00	METAL GLAZE	1K	5%	1/10W	
L15	1-459-982-11	COIL (WITH CORE)	R27	1-216-043-00	METAL GLAZE	560	5%	1/10W	
						1.5UH			
						3.3UH			
L16	1-459-979-11	(AEP,UK,Italian,Saudi Arabia) ...COIL (WITH CORE)	R28	1-216-105-00	METAL GLAZE	220K	5%	1/10W	
L16	1-459-981-11	(US,Canadian,E)...COIL (WITH CORE)	R29	1-216-058-00	METAL GLAZE	2.4K	5%	1/10W	
L17	1-406-255-11	COIL (OSC)	R31	1-216-062-00	METAL GLAZE	3.6K	5%	1/10W	
Q1	8-729-123-86	TRANSISTOR 2SK238	R33	1-216-085-00	METAL GLAZE	33K	5%	1/10W	
Q2	8-729-116-64	TRANSISTOR 2SK508-K51	R34	1-216-073-00	METAL GLAZE	10K	5%	1/10W	
Q3	8-729-220-93	TRANSISTOR 2SK209G	R35	1-216-081-00	METAL GLAZE	22K	5%	1/10W	
Q4	8-729-102-07	TRANSISTOR 2SC2223-F13	R36	1-216-049-00	METAL GLAZE	1K	5%	1/10W	
Q5	8-729-102-07	TRANSISTOR 2SC2223-F13	R38	1-216-069-00	METAL GLAZE	6.8K	5%	1/10W	
Q6	8-729-159-64	TRANSISTOR 2SD596	R39	1-216-069-00	METAL GLAZE	6.8K	5%	1/10W	
Q7	8-729-159-64	TRANSISTOR 2SD596	R40	1-216-097-00	METAL GLAZE	100K	5%	1/10W	
Q8	8-729-102-07	TRANSISTOR 2SC2223-F13	R41	1-216-057-00	METAL GLAZE	2.2K	5%	1/10W	
Q9	8-729-800-68	TRANSISTOR 2SB815	R42	1-216-049-00	METAL GLAZE	1K	5%	1/10W	
Q10	8-729-800-68	TRANSISTOR 2SB815	R43	1-216-246-00	(US,Canadian,E) ...METAL GLAZE	100K	5%	1/8W	
Q11	8-729-402-16	TRANSISTOR XN4608	R44	1-216-041-00	METAL GLAZE	470	5%	1/10W	
Q13	8-729-100-66	TRANSISTOR 2SC1623	R45	1-216-029-00	METAL GLAZE	150	5%	1/10W	
Q14	8-729-901-01	TRANSISTOR DTC144EK	R46	1-216-073-00	METAL GLAZE	10K	5%	1/10W	
R1	1-216-057-00	METAL GLAZE	R48	1-216-025-00	METAL GLAZE	100	5%	1/10W	
R2	1-216-053-00	METAL GLAZE	R49	1-216-059-00	METAL GLAZE	2.7K	5%	1/10W	
R3	1-216-091-00	METAL GLAZE	R50	1-216-748-11	METAL GLAZE	39K	5%	1/10W	
			R60	1-216-065-00	METAL GLAZE	4.7K	5%	1/10W	
						56K	5%	1/10W	

Ref.No.	Part No.	Description				
R61	1-216-065-00	METAL GLAZE	4.7K	5%	1/10W	
R62	1-216-295-00	METAL GLAZE	0	5%	1/10W	
R63	1-216-057-00	(US,Canadian,E) ...METAL GLAZE	2.2K	5%	1/10W	
R64	1-216-059-00	(US,Canadian,E) ...METAL GLAZE	2.7K	5%	1/10W	
R65	1-216-295-00	METAL GLAZE	0	5%	1/10W	
R66	1-216-295-00	METAL GLAZE	0	5%	1/10W	
R101	1-216-246-00	METAL GLAZE	100K	5%	1/8W	
R102	1-216-113-00	METAL GLAZE	470K	5%	1/10W	
R103	1-216-057-00	METAL GLAZE	2.2K	5%	1/10W	
R104	1-216-049-00	METAL GLAZE	1K	5%	1/10W	
R105	1-216-057-00	METAL GLAZE	2.2K	5%	1/10W	
R106	1-216-206-00	METAL GLAZE	2.2K	5%	1/8W	
R107	1-216-061-00	METAL GLAZE	3.3K	5%	1/10W	
R108	1-216-053-00	METAL GLAZE	1.5K	5%	1/10W	
R109	1-216-061-00	METAL GLAZE	3.3K	5%	1/10W	
R110	1-216-061-00	METAL GLAZE	3.3K	5%	1/10W	
R111	1-216-061-00	METAL GLAZE	3.3K	5%	1/10W	
R112	1-216-019-00	METAL GLAZE	56	5%	1/10W	
R113	1-247-713-11	CARBON	1K	5%	1/4W	
R114	1-249-417-11	CARBON	1K	5%	1/4W	
RV1	1-238-562-11	RES, VAR, CARBON 50K				
S1	1-554-979-11	SWITCH, SLIDE (SW BAND)				
S2	1-554-123-00	SWITCH, SLIDE (TONE)				
S101	1-554-978-11	SWITCH, KEY BOARD (FM)				
S102	1-554-978-11	SWITCH, KEY BOARD (MW)				
S103	1-554-978-11	SWITCH, KEY BOARD (SW)				
S104	1-554-978-11	SWITCH, KEY BOARD (OFF)				
S105	1-570-675-11	SWITCH, SLIDE (HOLD)				
SP1	1-544-156-11	SPEAKER				
T1	1-404-764-11	TRANSFORMER, IF				
T2	1-404-362-61	TRANSFORMER, IF				
T3	1-404-362-61	TRANSFORMER, IF				
T4	1-459-980-11	COIL				
X1	1-577-447-11	VIBRATOR, CERAMIC 16.8MHz				
X2	1-577-448-11	VIBRATOR, CERAMIC 17.9MHz				
X3	1-577-449-11	VIBRATOR, CERAMIC 20.4MHz				
X4	1-577-445-11	VIBRATOR, CERAMIC 22.63MHz				
X5	1-577-453-11	VIBRATOR, CERAMIC 26.025MHz				
X6	1-577-454-11	VIBRATOR, CERAMIC 28.525MHz				
X7	1-577-452-11	VIBRATOR, CERAMIC 32.35MHz				

ACCESSORY & PACKING MATERIAL

1-504-059-11	MAGNETIC EARPHONE (ME-20H)
3-703-264-11	LABEL (B), SERIAL NO
3-750-259-21	MANUAL, INSTRUCTION
3-893-940-05	(Saudi Arabia)....GUIDE, SHORT WAVE
3-893-940-15	(US,Canadian,E,AEP,UK,Italian) ...GUIDE, SHORT WAVE
*3-900-132-01	INDIVIDUAL CARTON
3-900-168-01	CARRYING CASE
*3-900-133-01	CUSHION