

SERVICE INFORMATION FOR THE STELLA RADIO RECEIVER TYPE ST113U

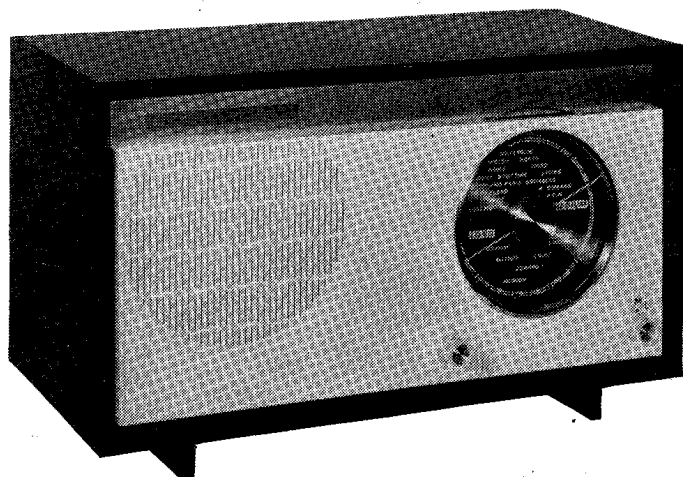

DESCRIPTION

The ST113U is a mains-operated table model covering medium/long wavebands and housed in a grey moulded cabinet. The design features a printed circuit and a high impedance loudspeaker.

SPECIFICATION

Valve Functions

V1 UCH81	Frequency changer.
V2 UBF89	I.F. Amplifier/Detector.
V3 UCL82	A.F. Amplifier and Output.
V4 UY85	Mains Rectifier.

Waveband Ranges

M.W. 187-500 metres.
L.W. 1175-2000 metres.

Mains Supply Voltages

200-220 and 220-250 volts.

Consumption

60 watts.

Loudspeaker

4 in. dia, high Z (800Ω).

Output

1 watt.

Cabinet Dimensions

12½ in. width. 7¼ in. height. 6¾ in. depth.

CAUTION

- (i) Live chassis—check polarity.
- (ii) The L.S. may be replaced only with a high impedance type (800Ω).
- (iii) The speech coil is at H.T. potential.

CHASSIS

Removal

Pull off the volume and w/change knobs, place the receiver face down on a protected surface and remove the backplate. Remove the two rear chassis screws, and the three screws securing the chassis to the front of the cabinet. Unsolder the loudspeaker leads and withdraw the chassis.

Assembly

Turn gang to maximum and set tuning drive coupling to a 9 o'clock position viewed from the rear of the cabinet. Carefully engage the pin on the gang with the slot in the tuner drive, before replacing the chassis fixing screws.

TRIMMING INSTRUCTIONS

General notes

- (i) Output is observed on an A.C. Voltmeter (10v range) connected to the speech coil via a 47kpf capacitor. V/C in maximum position.
- (ii) When trimming R.F. circuits, couple the generator to the receiver via a few turns of insulated wire wound on the ferrite rod aerial.

Section	W/Band & Pointer	Frequency	Injection point	Adjust for max. output
I.F.	M.W. Gang at min.	470kc/s	G1V1 via. 47kpf	L8-7-6-5
Osc. and R.F.	M.W. Gang at max.	510kc/s	G1V1 via. 47kpf	L4
	M.W. 580kc/s	580kc/s	Loose coupling Trimming Note (ii)	L1
	M.W. 1570kc/s	1570kc/s	As above	C7
	L.W. 190kc/s	190kc/s	As above	L2

Note.—Switch to M.W. and recheck trimming.

OFFICIAL SERVICE AGENT :—

AMALGAMATED ELECTRIC SERVICES LTD.

WADDON FACTORY ESTATE

CROYDON

SURREY

Telephone

CROYDON

7722

L	1, 2.	5, 6.	3, 4.	7, 8.	9.	L			
C	3, 12.	5, 7, 4, 14.	10, 9, 11.	13, 6, 8, 18, 19, 16.	20, 17, 21, 22, 2, 23, 27.	24, 26.	I, 25.	C	
R	22.	5, 21.	7, 6.	8.	11, 9, 10.	13, 12, 14, 4, 3, 15, 16, 2, 17.	18, 19.	20, I.	R

OSCILLATOR
& MIXER

I.F. AMPLIFIER
DETECTOR

A.F. AMPLIFIER

OUTPUT
RECTIFIER

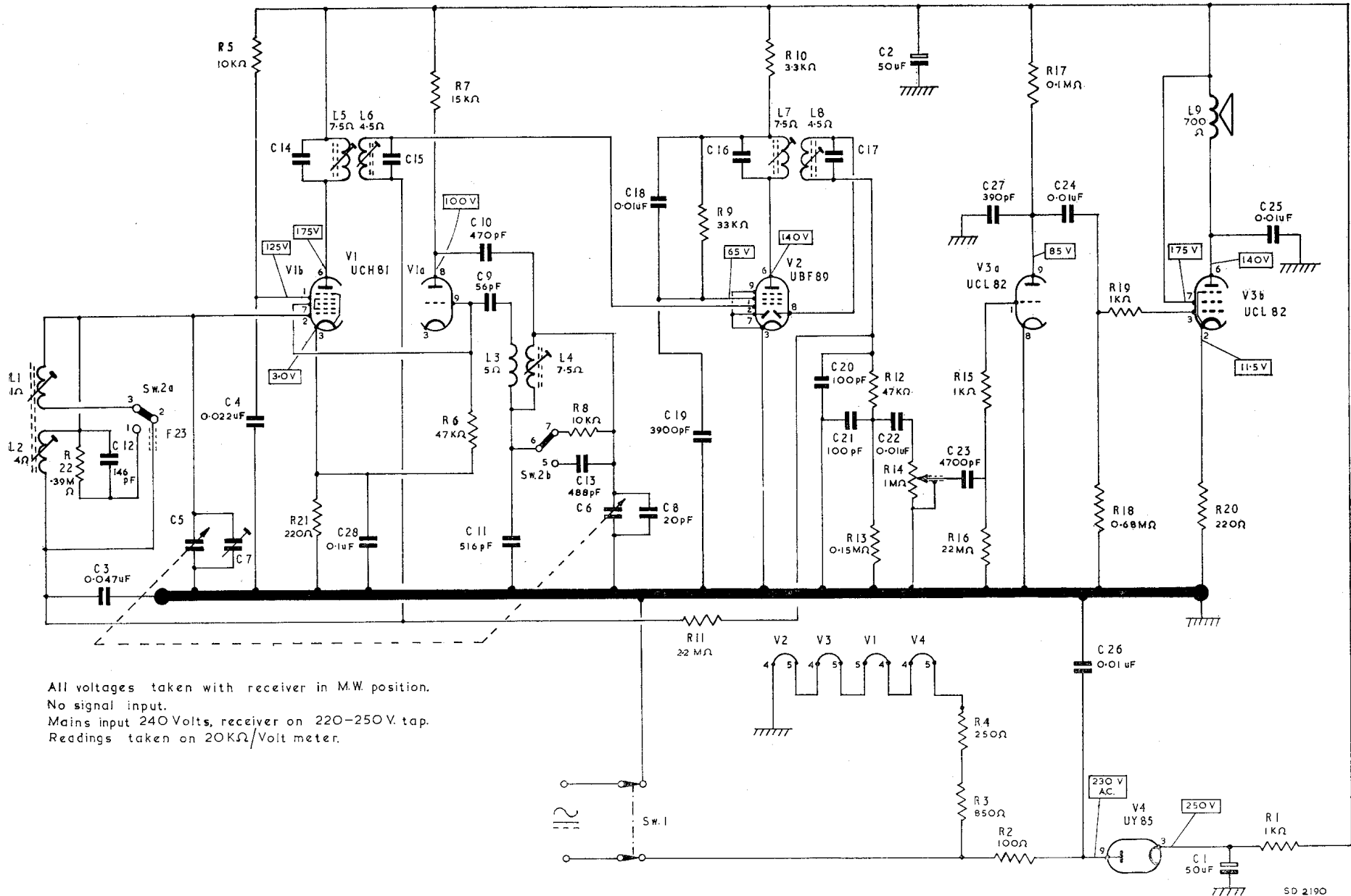

All voltages taken with receiver in M.W. position.
No signal input.
Mains input 240 Volts, receiver on 220-250 V. tap.
Readings taken on 20KΩ/Volt meter.

L						7, 8.					6.	1.		2.	4.				
C	27.	24.	26.	25.	19.		22, 17.	20.	21.	19.	13.	3.	10.	12.	9.	4.	11.	28.	
R	17.	18.				20.	15.	14.	16.	11.		7.	5.	8.		22.	6.		21.

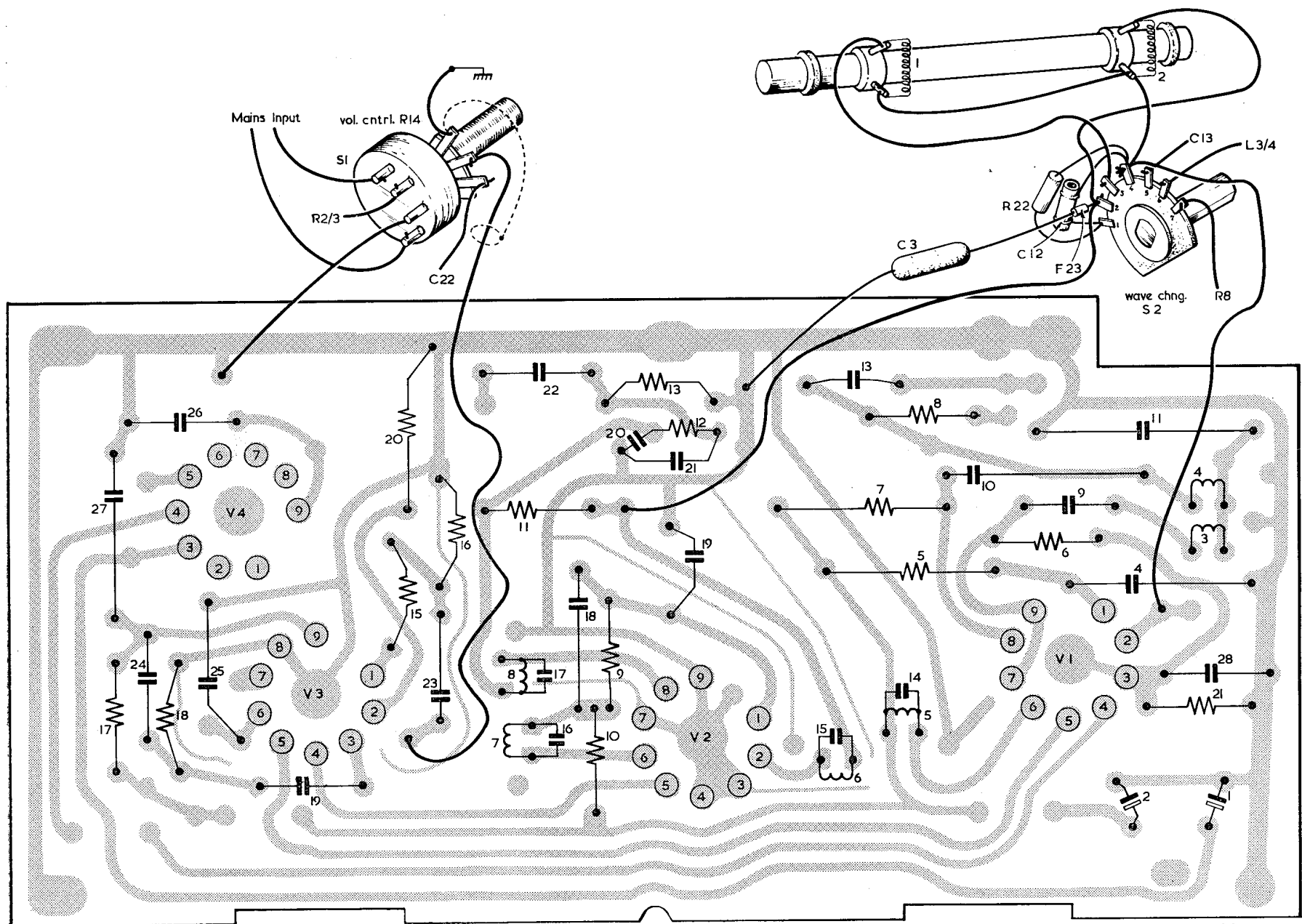

SPARE PARTS LIST

CABINET ASSEMBLY

Cabinet assembly	HY.074.55
Grille assembly	MK.835.34
Backing plate	MK.367.03
Fixing clips (6)	} for above	MK.999.10
Ornamental ring on grille		MK.451.44
Stella trade name	MK.708.33
Fixing clips for speaker (4)	MK.926.63
Station scale	MK.708.34

CONTROL KNOBS

On/off and volume	MK.858.14
Wavechange	MK.958.11
Clips for above (2)	MK.451.57
Tuning	MK.858.10
Coupling piece	} for above	MK.986.48
Felt washer		MK.450.51
Fixing clip		MK.962.21
Backplate	MK.367.49
Fixing clips (5)	MK.751.72
Special screws (5)	MK.946.88
Printed panel with components	MK.985.09

MISCELLANEOUS

Fixing clip for rear of chassis (2)	MK.955.91
Screw for above (2)	MK.946.88
Fixing screw for front of chassis (3)	B.071.TF/8N x 5/8
Grommet (3)	} for above	08.008.75
Distance piece (3)		B.001.AE/5.1 x 7 x 5
Washer (3)	B.050.ED/4
Mounting grommet for gang (3)	08.008.73
Distance piece for above (3)	B.001.AC/4.1 x 6 x 4
Threaded rod for R1-4	MK.645.83
Large washer	} fixing materials	MK.450.26
Lockwasher		B.053.BD/3
Nut (3)		B.020.EE/3
Asbestos washer		MK.448.61
Spring washer (2)	} for above	B.051.AH/3
Washer (2)		MK.449.53

Tapping clip for R1-4	MK.751.46
Heat screen for R1-4	MK.081.12
Insulating plugs for chassis (4)	MK.726.07
Valve screen	MK.252.34
Nut for controls (2)	MK.927.05
Cable clamp (2)	A3.469.42
Sleeving	K.558.LB/size
Insulating spindle for controls (2)	MK.004.48
Screw (2)	B.054.ED/3 x 8
Lockwasher (2)	B.053.AD/3
Coupling piece for gang	MK.986.77
Grub screw for above	B.061.ED/3 x 6
Aerial support bracket	MK.033.83
Switch—waveband	MK.999.09
Tag strip—general	MK.964.52
Mains lead	R.909.KA/803
Valve position label	PG.012.00
Licence plate	MK.707.29
Type label	MK.706.56
Fixing screw for gang (3)	B.808.AD/4N x 5/8
Valveholders	MK.225.89
Contact for valve screen	MK.939.12
Ceramic tube for R20	MK.117.62
Rod for aerial	56.681.22/4B

VALVES

V1	UCH81
V2	UBF89
V3	UCL82
V4	UY85

TRANSFORMERS AND COILS

L1/2	Rod aerial assembly...	MK.820.40
L1	M.W. aerial, coil only	MK.568.71
L2	L.W. aerial, coil only	MK.568.72
L3/4	Oscillator coil M.W.+L.W.	MK.569.25
L5/6	1st I.F. coil	MK.568.68
L7/8	2nd I.F. coil	MK.568.68
L11	Loudspeaker	ND.2350.AX

CAPACITORS

	Value	Permitted Tolerance %	
C1/2	Elco	50+50uF	AC.8307/50+50
C3	Polyester	47,000pF	C.296.AC/A47K
C4	Ceramic	22,000pF	C.301.GB/H22K
C5	} Gang
C6	
C7	MK.999.08
C8	Ceramic	20pF	C.304.GH/B20E
C9	Ceramic	56pF	C.304.AH/B56E
C10	Ceramic	470pF	C.304.AH/B470E
C11	Ceramic	516pF	C.304.GH/D516E
C12	Ceramic	146pF	C.304.AH/D146E
C13	Mica	488pF	MK.190.93
C14	In L5-6
C15
C16	In L7-8
C17
C18	Ceramic	10,000pF	C.301.GB/H10K
C19	Ceramic	3,900pF	MK.198.98
C20	} Diode filter	100pF	E.553.ZZ/03
C21		100pF	
R12
C22	Ceramic	10,000pF	C.301.GB/H10K
C23	Ceramic	4,700pF	C.322.BA/H4K7
C24	Ceramic	10,000pF	C.301.GB/H10K
C25	Ceramic	10,000pF	MK.206.10
C26	Ceramic	10,000pF	MK.206.10
C27	Ceramic	390pF	C.304.AH/A390E
C28	Polyester	0.1uF	C.296.AC/A100K

RESISTORS

	Value	Watts	Permitted Tolerance %
R1	1,000Ω	8.5	...
R2	100Ω	4.5	...
R3	850Ω	11.0	...
R4	250Ω	3.0	...
R5	10,000Ω	1	10
R6	47,000Ω	1	10
R7	15,000Ω	1	10
R8	10,000Ω	1	10
R9	33,000Ω	1	10
R10	3,300Ω	1	10
R11	2.2MΩ	1	10
R12	47,000Ω	1	10
C20	} Diode filter	...	E.553.ZZ/03
C21		...	
R13	0.15MΩ	1	10
R14	1MΩ	1	10
R15	1,000Ω	1	10
R16	22.0MΩ	1	10
R17	0.1MΩ	1	10
R18	0.68MΩ	1	10
R19	1,000Ω	1	10
R20	220Ω	1	10
R21	220Ω	1	10
R22	0.39MΩ	1	10
FR23	Ferroxcube bead