

FERRANTI**Model 435**

General Description : Seven-valve (including rectifier), three-waveband A.C. auto-radiogramophone with twin loudspeakers and a bass-compensated volume control. Automatic gain control is applied to the first audio amplifier. The record player is a three-speed B.S.R. "Monarch" unit.

Power Supply : A.C. mains, 200-250 volts (three adjustment taps).

Wavebands : S.W. 16-50 m.; M.W. 190-570 m.; L.W. 1000-2000 m.

Valve Analysis : Voltage (measured to chassis) and current readings are average. Measured under no-signal conditions using an Avometer Model 7.

Valve	Anode volts	Anode Current, mA.	Screen volts	Screen Current, mA.	Osc. Anode volts	Cathode volts
V1 ECH42	210	5	100	1.5	124	—
V2 EBF80	210	5.5	100	2	—	—
V3 EBF80	50	1	45	0.4	—	—
V4 ECL80 Pen. Tri.	75	1.6	45	0.3	—	3
	86	2.1	—	—	—	3
V5 PL82	215	37	210	10	—	14
V6 PL82	215	37	210	10	—	14
V7 PZ30	230 A.C.	—	—	—	—	—

Total D.C. through R47 114 mA. Bias across R45 2.5 v. Total A.C. at input 0.4 amp. To check oscillator earth its grid and note that the anode volts fall by about 20 volts.

Alignment Procedure : Note that chassis is "live".

I.F.: Switch to L.W. with tuning gang fully enmeshed. Set tuning core of L15 fully out. Inject 470-kc/s. signal via 0.1- μ F. capacitor to V1 signal grid, i.e., front section of tuning gang. Adjust cores of L16, L14 and L13 for maximum gain. Each core has two tuning positions, the correct one is the first as the core is screwed into the coil. Repeat adjustments until no further gain. Finally, adjust L15 for maximum gain (first tuning position).

R.F.: Calibration points are marked on the cross-rail carrying pointer. Check that with tuning gang fully enmeshed, the pointer coincides with the extreme right-hand calibration mark. Inject alignment signals through appropriate dummy aerial to aerial socket.

Operation	Generator Frequency	Receiver Tuning	Adjust for Optimum Response
(1) M.W. . . .	600 kc/s.	600 kc/s.	L9, then L4
(2)	1500 kc/s.	1500 kc/s.	C21, then C5
(3)		Repeat (1) and (2)	
(4)	470 kc/s.	Fully enmeshed	L1 for <i>minimum</i>
(5) L.W.	166.6 kc/s.	166.6 kc/s.	L11, then L6
(6)	266 kc/s.	266 kc/s.	C15, then C6
(7)		Repeat (5) and (6)	
(8) S.W.	6.67 Mc/s.	6.6 Mc/s.	L7,* then L2
(9)	15 Mc/s.	15 Mc/s.	C19,† then C4
(10)		Repeat (8) and (9)	

* First tuning position as core is screwed in.

† Lower capacitance tuning position.

W/C SECTIONS VIEWED
FROM KNOB END OF SWITCH

RESISTORS
ALL VALUES ARE GIVEN IN OHMS
K, 1000, M, 1000 000
CONDENSERS
ALL VALUES ARE GIVEN IN
MICRO-MICROFARADS UNLESS
OTHERWISE STATED

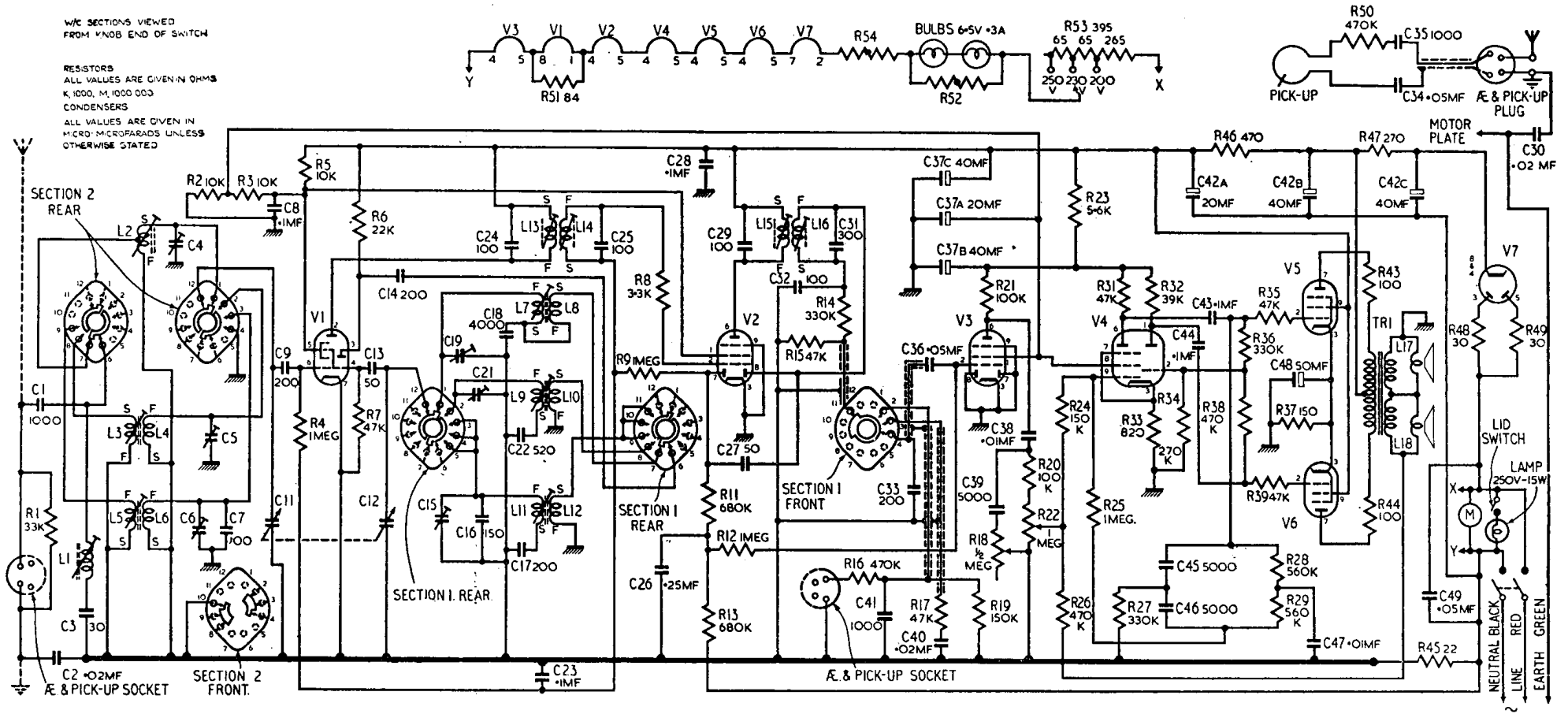

CIRCUIT DIAGRAM—FERRANTI MODEL 435

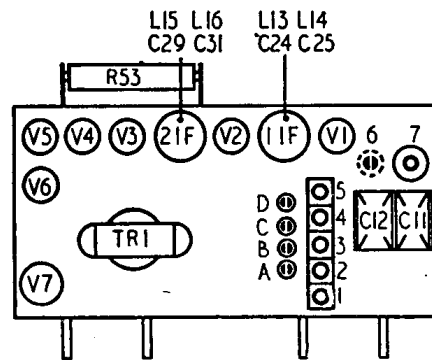
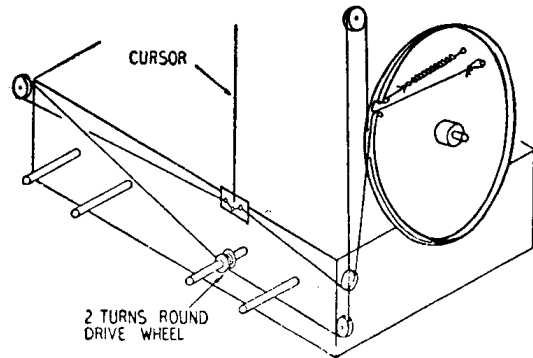
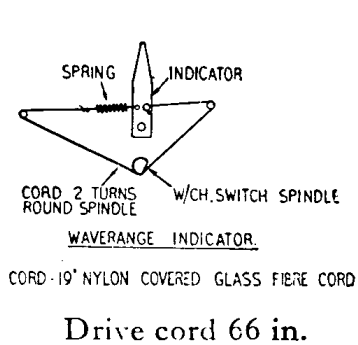

REF	COILS	REF	TRIMMERS
1	L7-L8 S.W. OSC.	A	C19 S.W. OSC.
2	L11-L12 L.W. OSC.	B	C15 L.W. OSC.
3	L9-L10 M.W. OSC.	C	C21 M.W. OSC.
4	L2 S.W. A.E.	D	C4 S.W. A.E.
5	L1 I.F. TRAP	E	C6 L.W. A.E.
6	L3-L4 M.W. A.E.	F	C5 M.W. A.E.
7	L5-L6 L.W. A.E.		

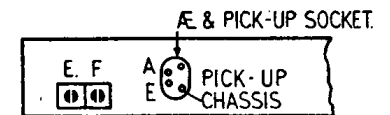

FERRANTI