

"TRADER" SERVICE SHEET
897

FERRANTI 147

With Two Switched Pre-set Stations

THREE wavebands and two pre-selected M.W. stations are available on a five-position control in the Ferranti 147, a 4-valve (plus rectifier) superhet designed to operate from A.C. mains of 200-250V, 50-100 c/s. Provision is made for the connection of a gramophone pick-up and an external speaker, and the internal speaker may be muted.

Some models are fitted with Ferranti receiving valves, in addition to the rectifier, and the modifications involved are explained overleaf.

Release date and original price: September, 1947, £24 10s., plus purchase tax.

CIRCUIT DESCRIPTION

Aerial input is via coupling coils L2 (S.W.), L3 (M.W.) and L4 (L.W.) to single-tuned circuits L7, C32 (S.W.), L8, C32 (M.W.) and L9, C32 (L.W.). For aerial pre-set tuning, at positions four and five on the waveband switch, all the fore-

going circuits are disconnected and replaced by one of the iron-dust pre-set coils L5, L10 (200-340 m, P.S.1) or L6, L11 (320-560 m, P.S.2), tuned by C4 and selected by S13, S14. I.F. filtering is by L1, C1.

First valve (V1, Mullard metallized ECH35) is a triode-hexode operating as frequency changer with internal coupling. Triode oscillator grid coils L12 (S.W.), L13 (M.W.) and L14 (L.W.) are tuned by C33, with parallel trimming by C34 (S.W.), C35 (M.W.) and C9, C36 (L.W.), and series tracking by C10 (S.W.), C11 (M.W.) and C12 (L.W.). Inductive reaction coupling by L17 (S.W.), L18 (M.W.) and L19 (L.W.).

For oscillator pre-set tuning L14, L19 is employed as a master oscillator, shunted by one of the iron-dust pre-set coils L15 (P.S.1) or L16 (P.S.2), selection being achieved by S21, S27 or S22, S28 respectively.

Second valve (V2, Mullard metallized

EF39) is a variable- μ R.F. pentode operating as intermediate frequency amplifier with tuned transformer couplings C5, L20, L21, C6 and C15, L22, L23, C16. The coil cores are adjustable.

Intermediate frequency 465 kc/s.

Diode second detector is part of double diode triode valve (V3, Mullard metallized EBC33). Audio frequency component in rectified output is developed across diode load resistor R10 and passed, via A.F. coupling capacitor C20 and manual volume control R11, to grid of triode section, which operates as A.F. amplifier. I.F. filtering by C18, R8, C19 in diode circuit, and by C24 in V4 control grid circuit. Provision for the connection of a gramophone pick-up between the signal diode anode and chassis, which automatically mutes radio reproduction.

Second diode of V3, fed from V2 anode via C21, provides D.C. potentials, which are developed across load resistor R15 and

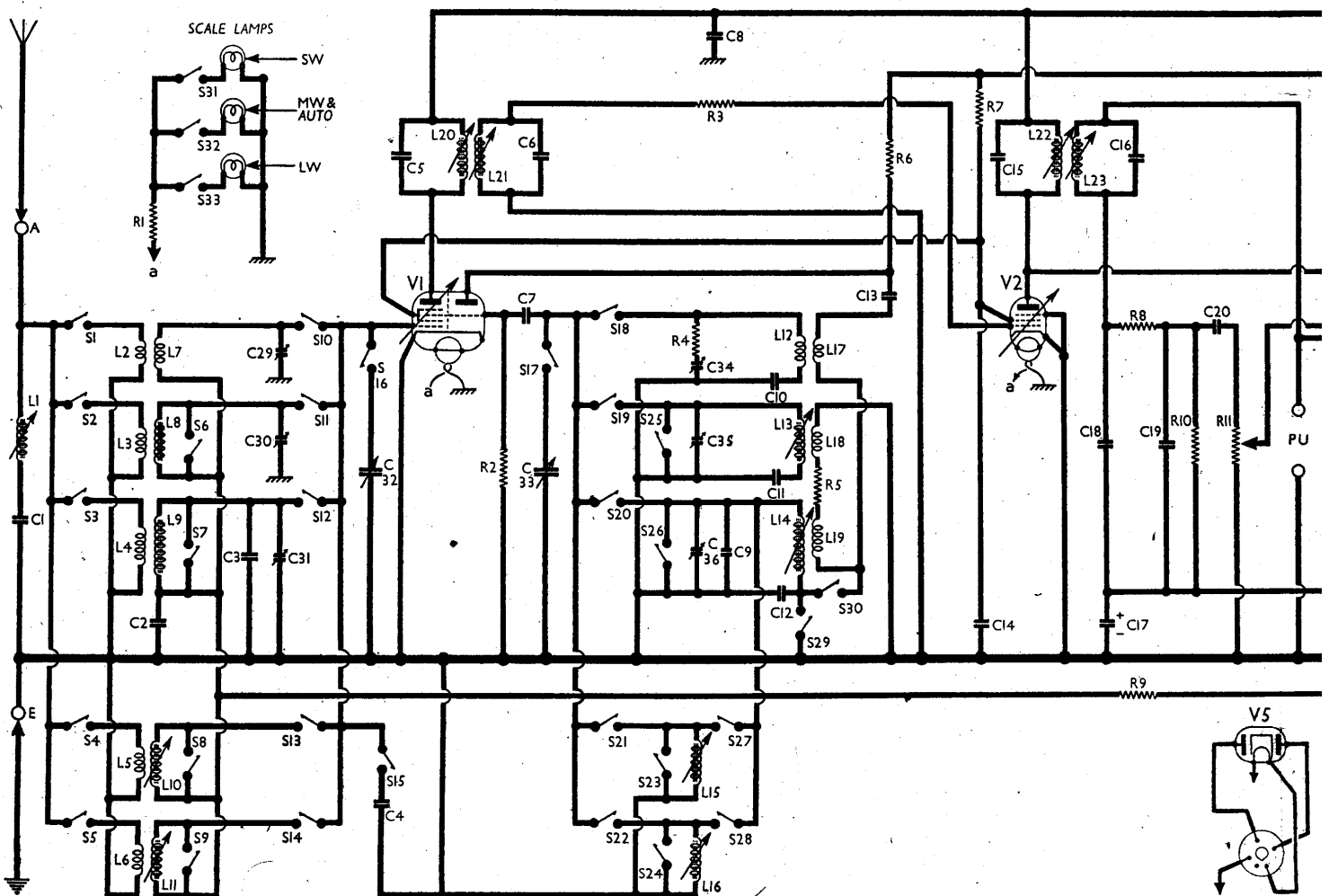

fed back through a decoupling circuit R9, C2 as G.B. to F.C. and I.F. valves, giving automatic gain control. Delay voltage, together with fixed G.B. for V1, V2 is obtained from the drop across R20 in the H.T. negative lead to chassis.

Resistance capacitance coupling by R14, C23, R16 between V3 triode and pentode output valve (V4, Mullard EL33). Variable tone control by R16, C25 and fixed tone correction by R18, C26. Provision for the connection of a low impedance external speaker across T1 secondary winding.

H.T. current is supplied by I.H.C. full-wave rectifying valve (V5, Ferranti R52). Smoothing by speaker field L26 and electrolytic capacitors C27, C28. H.T. circuit R.F. filtering by C8.

VALVE ANALYSIS

Valve voltages and currents given in the table below are those measured in our re-

Valve	Anode Voltage (V)	Anode Current (mA)	Screen Voltage (V)	Screen Current (mA)
V1 ECH35	267 87 87	3.8 5.1 5.1	115	1.6
V2 EF39	267	7.1	115	2.2
V3 EBC33	105	1.2	—	—
V4 EL33	255	33.0	267	3.8
V5 R52	300†	—	—	—

† Each anode, A.C.

ceiver when it was operating from 207 V mains, using the 200 V tapping on the mains transformer.

The receiver was tuned to the lowest wavelength on the M.W. band, and the volume control was at maximum, but there was no signal input. Voltages were measured on the 400 V scale of a model 7 Avometer, chassis being the negative connection.

COMPONENTS AND VALUES

RESISTORS		Values (ohms)	Locations.
R1	Scale lamp ballast	7*	G4
R2	V1 osc. C.G.	47,000	H6
R3	V2 C.G. stopper	2,200	D3
R4	S.W. stabilizer	10	J6
R5	Osc. stabilizer	470	K6
R6	Osc. anode load	22,000	G6
R7	V1, V2 S.G.'s feed	22,000	F6
R8	I.F. stopper	100,000	D3
R9	A.G.C. decoupling	2,200,000	E6
R10	Sig. diode load	470,000	D3
R11	Volume control	1,000,000	E4
R12	V3 G.B., A.G.C. delay	2,200	E6
R13	H.T. decoupling	6,800	G5
R14	V3 triode load	68,000	E6
R15	A.G.C. diode load	2,200,000	E6
R16	Tone control	500,000	K4
R17	V4 G.B. resistor	150	E5
R18	Part tone corrector	22,000	F5
R19	V4 anode stopper	100	F5
R20	V1, V2, Fixed G.B.	56	F7
R21	H.T. shunt	22,000	G5

* Resistance lead.

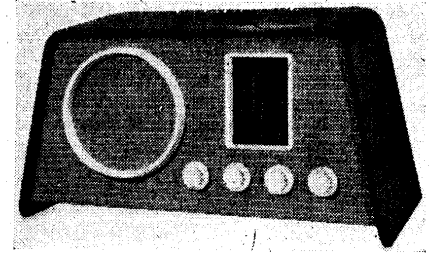

CAPACITORS		Values (µF)	Locations
C1	I.F. filter tune	0.00003	J6
C2	A.G.C. decoupling	0.1	H5
C3	Aerial L.W. trim.	0.00005	K4
C4	Aerial P.S. tuning	0.00012	H4
C5	1st I.F. trans.	0.000105	D3
C6	tuning	0.000105	D3
C7	V1 osc. C.G.	0.0001	H6
C8	H.T. R.F. by-pass	0.1	G5
C9	Osc. L.W. trim.	0.0001	K6
C10	Osc. S.W. trim.	0.004	K6
C11	Osc. M.W. tracker	0.0005	J5
C12	Osc. L.W. tracker	0.00013	K6
C13	Osc. anode coup.	0.001	J6
C14	V1, V2 S.G.'s decoupling	0.1	G6
C15	2nd I.F. transform-	0.00009	D3
C16	er tuning	0.000105	D3
C17*	V3 cath. by-pass	50.0	K5
C18	I.F. by-passes	0.00015	D3
C19	I.F. by-passes	0.00015	D3
C20	A.F. coupling	0.02	E4
C21	A.G.C. coupling	0.00005	E6
C22*	H.T. decoupling	4.0	F7
C23	A.F. coupling	0.05	E6
C24	I.F. by-pass	0.0004	E5
C25	Part tone control	0.01	J4
C26	Part tone corrector	0.005	E5
C27*	H.T. smoothing	16.0	G7
C28*	capacitors	12.0	F7
C29†	Aerial S.W. trim.	0.00004	J5
C30†	Aerial M.W. trim.	0.00004	K5
C31†	Aerial L.W. trim.	0.00004	K5
C32†	Aerial tuning	—	C2
C33†	Oscillator tuning	—	C2
C34†	Osc. S.W. trim.	0.00004	J6
C35†	Osc. M.W. trim.	0.00004	J5
C36†	Osc. L.W. trim.	0.00004	K6

*Electrolytic. †Variable. ‡Pre-set.

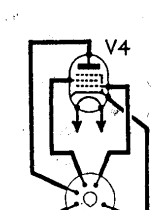
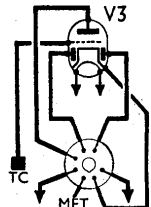
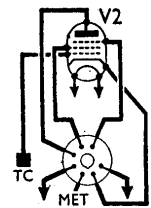
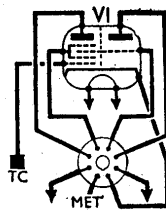
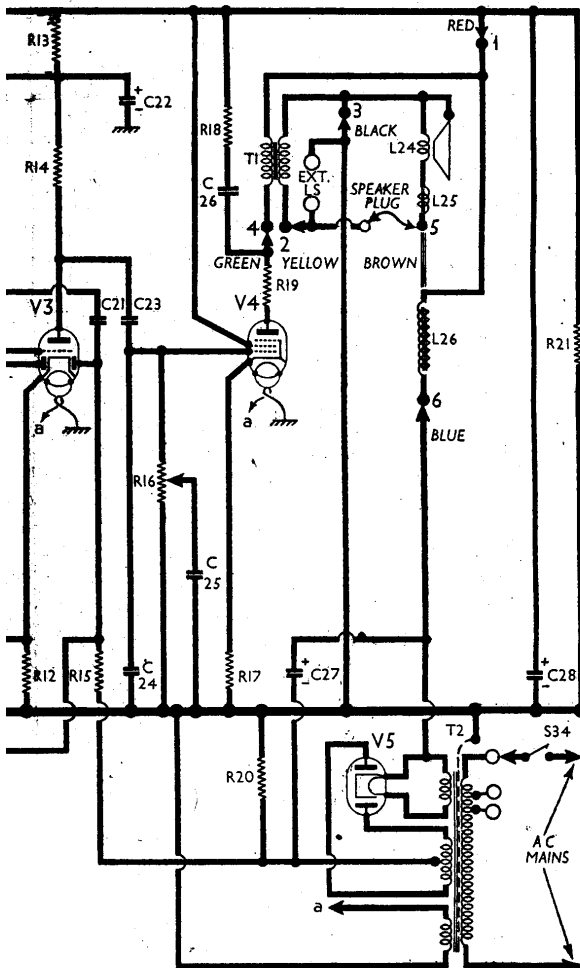

Circuit diagram of the Ferranti 147 A.C. 3-band superhet. In the fourth and fifth positions of the waveband control, the pre-set tuning circuits shown below the chassis line are brought into circuit, the oscillator coils (L15 or L16) being shunted across the L.W. manual oscillator coil L14, which then operates as a master oscillator, S29 closing to short-circuit C12. S16 and S17 open to disconnect the gang, which is replaced in the aerial circuit by the fixed capacitor C4.

OTHER COMPONENTS		Approx. Values (ohms)	Locations.	
L1	I.F. filter coil	21.0	J6	
L2		0.6	J5	
L3		33.0	K5	
L4	Aerial coupling coils	50.0	K5	
L5		0.8	K7	
L6		1.6	J7	
L7		0.1	J5	
L8		3.5	K5	
L9	Aerial tuning coils	18.5	K5	
L10		5.2	K7	
L11		8.4	J7	
L12	Oscillator tuning coils	Very low	J6	
L13		4.0	J5	
L14		10.5	K6	
L15	Oscillator reaction coils	4.0	J7	
L16		4.5	J7	
L17		0.4	J6	
L18		1.2	J5	
L19		4.0	K6	
L20	1st I.F. trans.	Pri. ...	9.0	D3
L21		Sec. ...	9.0	D3
L22	2nd I.F. trans.	Pri. ...	9.0	D3
L23		Sec. ...	9.0	D3
L24	Speech coil	1.8	—	
L25	Hum neut. coil	Very low	—	
L26	Field coil	1,000.0	—	
T1	Speaker trans.	Pri. ...	200.0	—
		Sec. ...	0.1	—
	Pri. total Rect. heat. sec.	27.5	A3	
T2		Mains trans. H.T. sec., total...	0.1	A3
S1-S33	W/band switches	210.0	A3	
S84	Mains sw., g'd R16	0.1	A3	
		—	—	
		—	K4	

DISMANTLING THE SET

Removing Chassis.—Remove the four control knobs (pull off), and the two 2BA cheese-head screws (with washers) securing the rear bottom corners of the chassis to its metal cradle inside the cabinet;

if the rear edge of the chassis is now lifted slightly it may be slid from the cabinet to the extent of the speaker leads, which is sufficient for most purposes.

To free the chassis entirely, unsolder the six coloured plastic covered leads at tags on the speaker transformer.

When replacing, if the speaker leads have been disconnected they should be resoldered as follows, numbering the tags on the speaker transformer connecting panel from left to right: 1, red; 2, yellow; 3, black; 4, green; 5, brown; 6, blue.

Removing Speaker.—Withdraw the four cheese-head screws (with washers) securing speaker to sub-baffle, and lift it out.

When replacing, if the connecting leads have been unsoldered, they should be replaced in the order previously described, with the transformer at the top.

GENERAL NOTES

Switches.—S1-S33 are the waveband and pre-set tuning switches, ganged in three rotary units beneath the chassis. These units are indicated in our under-chassis view, and shown in detail in the diagrams in col. 2, where they are drawn as seen when viewed from the rear of the chassis.

The table in col. 3 gives the switch positions for the five control settings, starting from the fully anti-clockwise position of the control knob. A dash indicates open, and C, closed.

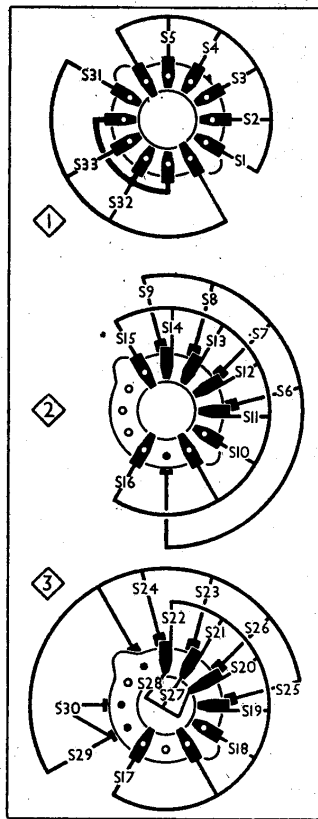

Diagrams of the three waveband switch units, drawn as seen when viewed from the rear of an inverted chassis, the top diaphragm here being the front unit in the chassis. The associated switch table is on the right.

Switch	S.W.	M.W.	L.W.	Pre-set 1	Pre-set 2
S1	C	—	—	—	—
S2	—	C	—	—	—
S3	—	—	C	—	—
S4	—	—	—	C	—
S5	—	—	—	—	C
S6	—	—	—	—	—
S7	C	C	C	C	C
S8	C	C	C	C	C
S9	C	C	C	C	C
S10	C	C	C	C	C
S11	—	C	—	—	—
S12	—	—	C	—	—
S13	—	—	—	C	—
S14	—	—	—	—	C
S15	—	—	—	—	—
S16	C	C	C	C	C
S17	—	—	—	—	—
S18	—	—	—	—	—
S19	—	—	—	—	—
S20	—	—	—	—	—
S21	—	—	—	C	—
S22	—	—	—	—	C
S23	—	—	—	—	—
S24	C	C	C	C	C
S25	C	C	C	C	C
S26	C	C	C	C	C
S27	—	—	—	—	—
S28	—	—	—	—	—
S29	—	—	—	C	—
S30	C	—	—	—	—
S31	—	—	—	—	—
S32	—	C	—	—	—
S33	—	—	C	—	—

S34 is the Q.M.B. mains switch, ganged with the variable tone control R16.

Scale Lamps.—These are three M.E.S. type lamps, with clear spherical bulbs, rated at 6.0 V, 0.3 A, or 6.5 V, 0.3 A.

Gramophone Pick-up.—Two sockets are provided at the rear of the chassis for the connection of a gramophone pick-up, but as these are not switched, the upper plug must be withdrawn to revert to radio operation. The connection of the pick-up applies a negative bias to the signal diode, muting radio.

If a crystal pick-up is used, it should be coupled by a step-down network, one resistive limb of which should shunt the P.U. sockets.

External Speaker.—Three sockets are provided at the rear of the chassis for the connection of an external speaker, which should have a low impedance (about 2.5 Ω). The external speaker plugs go into the top and bottom sockets. The centre socket is usually occupied by a plug on a flying lead, but if this is withdrawn, the internal speaker can be muted.

Resistor R1.—This is the scale lamp ballast resistor, which consists of a length of resistance wire in red sleeving, running from V2 holder to No. 1 waveband switch unit. Its value is 7 Ω.

Chassis Divergencies.—Some chassis are fitted with the following Ferranti valves: 6K8G, 6K7G, 6Q7G and 6V6G, when R7 becomes 15,000 Ω, R14 becomes 100,000 Ω, R17 becomes 270 Ω, R20 becomes 47 Ω and R4 and R21 are omitted.

DRIVE CORD REPLACEMENT

Two drive cords are used in this receiver: the main gang drive cord, a simple loop round the gang drum and control spindle; and the cursor drive cord, which turns a right-angle from the plane of the drum and completely encircles the scale lamp enclosure.

The run of each cord is shown in the sketch (Col. 5), the gang drive cord being dotted to distinguish it from the other.

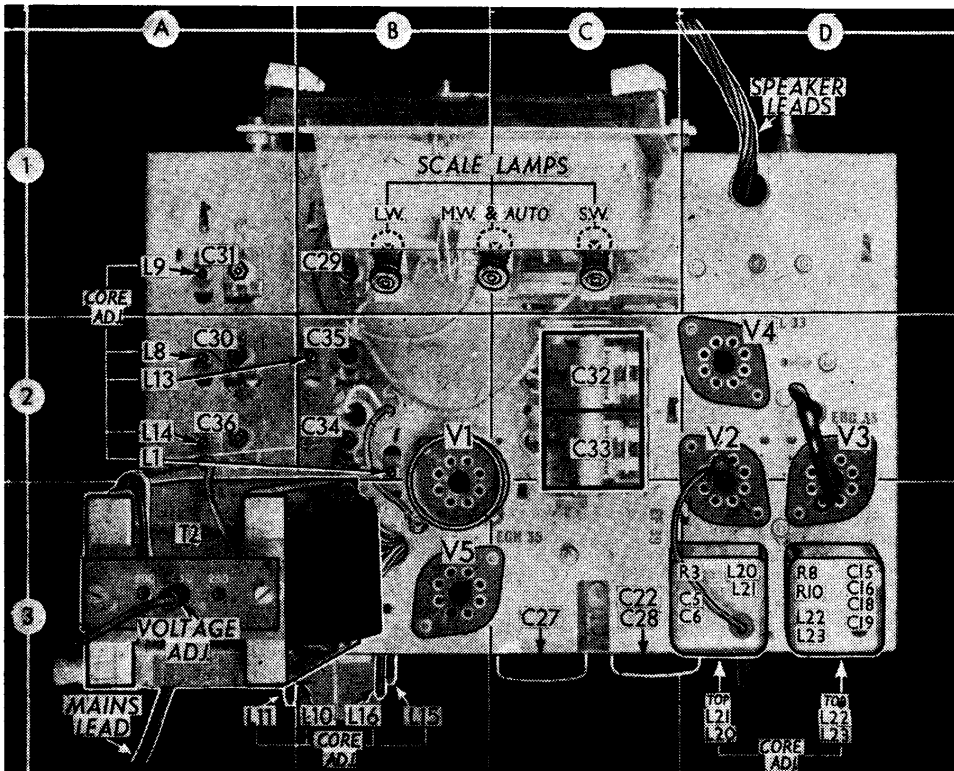

Plan view of the chassis. The four core adjustments for the pre-set tuning circuits are seen projecting from the rear. Between them is a calibrated scale to indicate the approximate wavelength.

It is drawn as seen from the rear, as that is the side from which it is fitted. It is advisable to remove the scale lamp holders from their brackets, as otherwise their leads get in the way, and if both cords are to be replaced, the cursor drive should be fitted first.

Cursor Drive.—First remove the glass scale panel by slackening the screws holding the bottom clamps and removing those holding the top clamps. The run of the cord can be seen quite clearly from the sketch, but there is some difficulty in fitting it, as the inner side of the gang drum faces the gang unit, and is thus not easily accessible.

The best method is to turn the gang to maximum, as shown in our sketch, take about three feet of Nylon plaited yarn, and pass one end into the appropriate slot in the drum groove and tie it to the spring, which may be left unanchored. Then run the cord in the direction indicated by the arrows, pulling on it to keep it in position.

Finally, pass the free end into the drum slot, draw out the spring, and tie both ends of the cord to it so that the spring is well extended, and cut off the surplus cord, of which there should be about six inches. The actual process of hooking the spring to its anchorage is most conveniently carried out with the gang turned to a point near minimum capacitance.

The cursor can be slipped on in approximately the correct position before replacing the scale panel, final adjustment being made as explained under "General Notes." The scale panel is held in moulded rubber blocks which are clamped by metal brackets. The top brackets have felt pads cemented to them to keep the scale from touching the front of the cabinet.

Gang Drive.—Two feet of cord is required for this, and fitting is fairly simple. If the two ends are tied loosely to the spring, the loop can be fed out through the slot in the drive drum rim and passed down to the control spindle, which has a free end over which the cord can be slipped.

The cord can then be held taut above the deck while it is fed round the rim of the drum to give a measure of the length required before tying off the ends firmly to the spring. As with the cursor drive, the best position of the gang for hooking on the spring is near minimum capacitance.

CIRCUIT ALIGNMENT

I.F. Stages.—Connect signal generator, via an 0.05 μ F capacitor in the "live" lead, to control grid (top cap) of V1 and chassis. Switch set to L.W., turn volume control and gang capacitor to maximum, feed in a 465 kc/s (645.16 m) signal, and adjust the cores of L20, L21, L22 and L23 (location reference D3) for maximum output.

I.F. Filter.—Transfer "live" signal generator lead, via a suitable dummy aerial, to A socket, switch set to M.W. and tune to 550 m on scale, feed in a strong 465 kc/s signal, and adjust the core of L1 (B2) for minimum output.

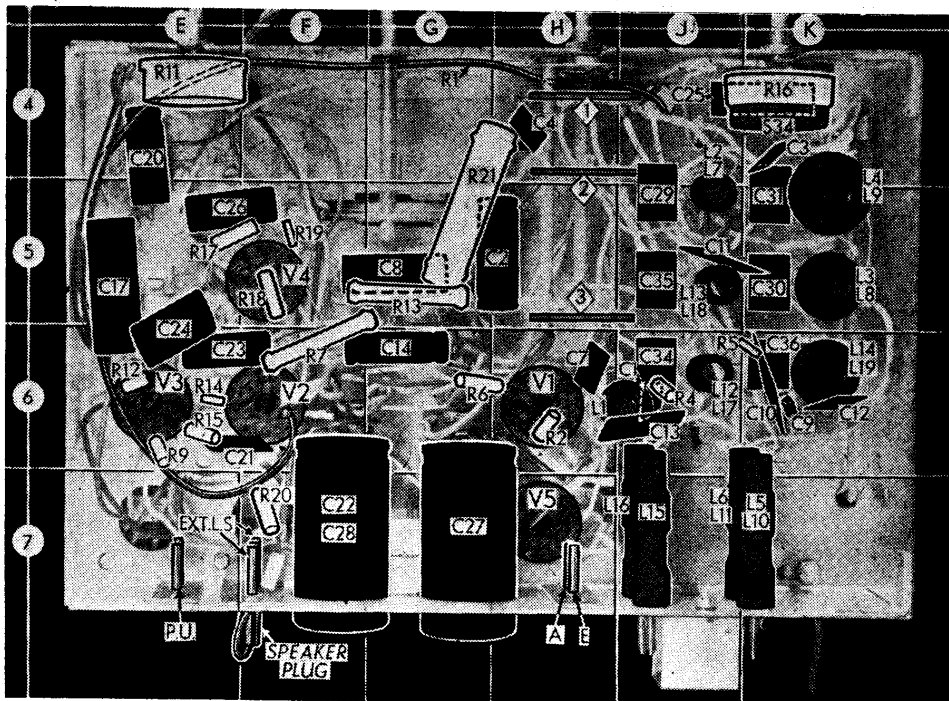

Under-chassis view. The waveband switch units are indicated here by the numbers 1, 2, 3 in diamonds, and shown in detail in the diagrams in col. 2. R1 is a length of wire in sleeving, running round two sides of the chassis.

R.F. and Oscillator Stages.—With the gang at maximum capacitance the pointer should be coincident with the horizontal lines at the high wavelength ends of the three scales. It may be adjusted in position by rotating the drive drum on its spindle, after slackening the two grub screws.

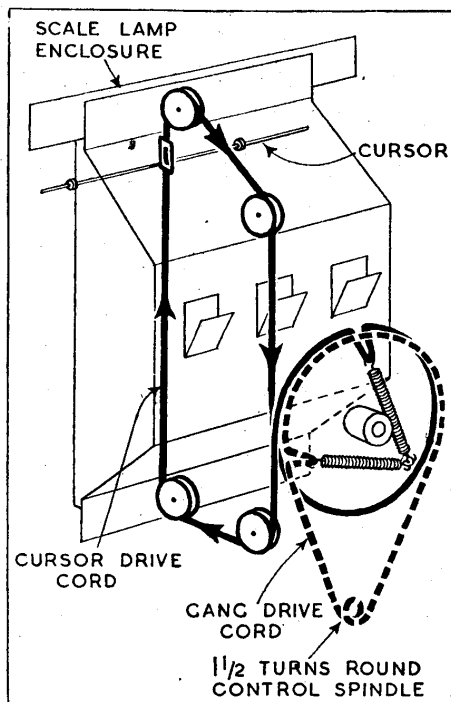

Sketch showing the tuning drive system, as seen from the rear with the gang at maximum.

M.W.—Switch set to M.W., tune to 200 m on scale, feed in a 200 m (1,500 kc/s) signal, and adjust C35 (B2) for maximum output. Feed in a 228 m (1,316 kc/s) signal, tune it in, and adjust C30 (A2) for maximum output. Tune to 500 m on scale, feed in a 500 m (600 kc/s) signal, and adjust the cores of L13 and L8 (B2, A2) for maximum output. Repeat these operations until no improvement results.

L.W.—Switch set to L.W., tune to 1,000 m on scale, feed in a 1,000 m (300 kc/s) signal, and adjust C36 (A2) for maximum output. Feed in an 1,128 m (266 kc/s) signal, tune it in, and adjust C31 (A1) for maximum output. Tune to 1,800 m on scale, feed in a 1,800 m (168 kc/s) signal, and adjust the cores of L14 and L9 (A2, A1) for maximum output. Repeat these operations until no improvement results. Finally, with set still switched to L.W., feed in a strong 261 m (1,149 kc/s) signal, tune it in at about 1,370 m on scale, and reduce the image signal output to minimum by varying the relative positions of the "live" connecting leads to L4 and L9 (K5).

Switch set to S.W., tune to the 200 m calibration mark on the M.W. scale (this corresponds to 16.67 m on S.W. scale), screw up C34 (B2) to maximum capacitance, and unscrew C34 until the second peak is obtained. Feed in a 20 m (15 Mc/s) signal, tune it in, and adjust C29 (B1), while rocking the gang, for maximum output. Tune to 45 m on scale, feed in a 45 m (6.67 Mc/s) signal, and adjust the positions of the "live" leads of L12 (J6) and L7 (J5) for maximum output. Repeat these operations until no improvement results.