

"TRADER" SERVICE SHEET

721

FERRANTI ARCADIA 1934-5 AND ARCADIAGRAM

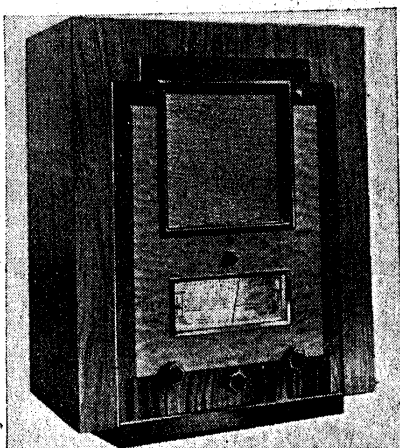

The appearance of the Ferranti Arcadia 1934-5 AC superhet. The small knob above the scale is the tone control.

FOUR receiving valves, including a directly heated triode output valve, and a rectifier, are employed in the Ferranti Arcadia 1934-5 receiver, a 2-band superhet designed to operate from AC mains of 200-250 V, 40-100 c/s.

Differences in a later version than ours, with a method of identification of such chassis, are explained under "Chassis Divergencies" overleaf.

An identical chassis was employed in the Arcadiagram radiogram, but a transformer is included in the pick-up input circuit.

Release date, both models, 1934.

Original prices: Arcadia, £15 15s.; Arcadiagram, £31 10s.

CIRCUIT DESCRIPTION

Aerial input via coupling coils **L1** (MW) and **L2** (LW) to mixed coupled band pass filter. Primary coils **L3**, **L4** are tuned by **C25**; secondaries **L8**, **L9** by **C27**. Coupling by **L6** (MW) and **L7**, which is formed by a few turns at the bottom of **L9**, on LW, with capacitive coupling by the common impedance of **C2**.

First valve (**V1**, Ferranti metallised **VHT4**) is a heptode operating as frequency changer with electron coupling. Oscillator grid coils **L10** (MW) and **L11** (LW) are tuned by **C29**. Parallel trim-

ming by **C30** (MW); series tracking by **C31** (MW) and **C32** (LW). CG resistor **R4** is in low potential end of circuit, across **R4**.

Reaction coupling from anode by coils **L12**, **L13**, augmented by the common impedance of **C31**, **C32** via **C7**. Image suppression by **L5** (MW) in **V1** cathode lead to chassis. On LW, **V1** cathode RF path to chassis is via **S4**, **C5**, by-passing **L5**.

Second valve (**V2**, Ferranti metallised **VPT4**) is a variable- μ RF pentode operating as intermediate frequency amplifier with tuned-primary, tuned-secondary transformer couplings **C33** (returned to cathode) **L14**, **L15**, **C34** and **C35**, **L16**, **L17**, **C36**.

Intermediate frequency 125 kc/s.

Diode second detector is part of double diode triode valve (**V3**, Ferranti metallised **H4D**). Audio frequency component in rectified output is developed across load resistor **R12** and passed via AF coupling capacitor **C14**, tag **X** to the upper pick-up terminal and manual volume control **R13** to CG of triode section, which operates as AF amplifier.

IF filtering by **C12**, **R11**, **C13** in diode circuit, and **C17** in triode anode circuit. Provision for connection of gramophone

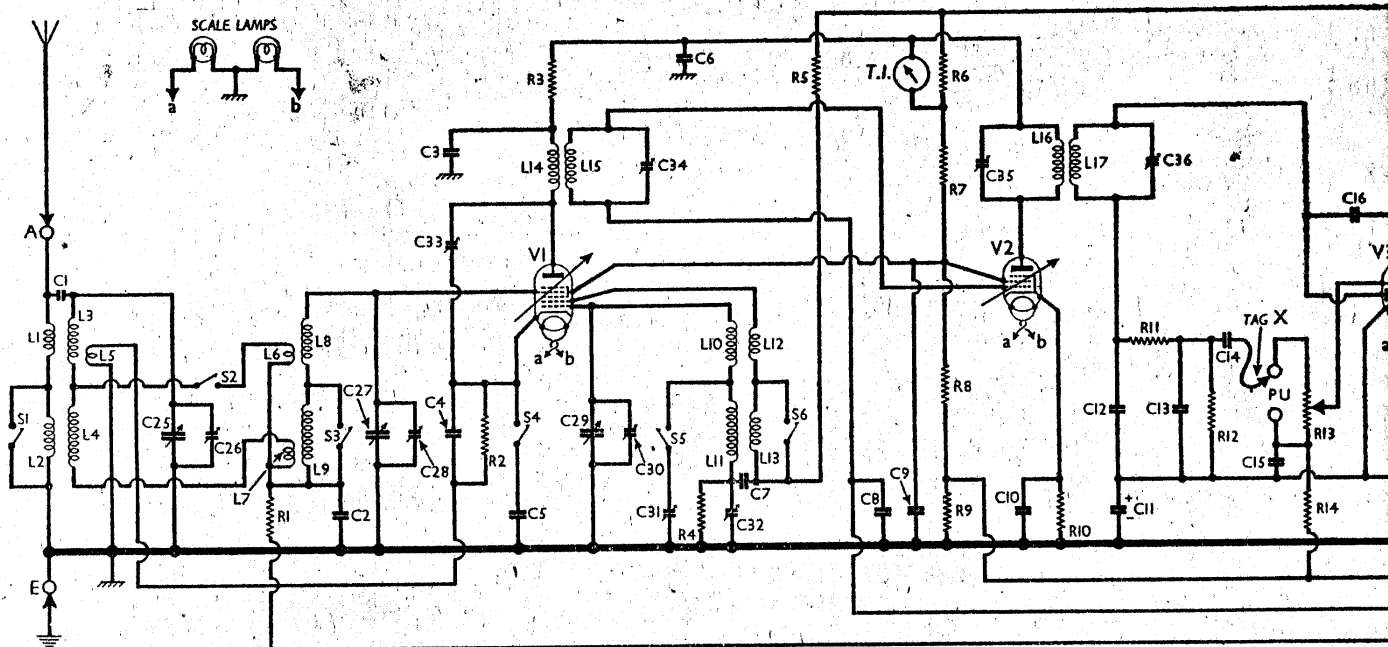

Circuit diagram of the Ferranti Arcadia 1934-5 superhet, serial numbers 54,000 to 69,999. The differences in a modified version, which lie between 200,000 and 210,000, concern the omission of the HT potential divider **R6**, **R7**, **R8**, **R9**, and are described overleaf. The **V3** triode and **V4** is mainly resistance-capacitance, but a special AF transformer is included to obtain high-note emphasis. Tag **X** pick-up operation.

pick-up by terminals across **R13**, radio being muted by the disconnection of tag **X**.

Second diode of **V3**, fed from **L17** via **C16**, provides DC potentials which are developed across load resistors **R16**, **R17** and fed back through decoupling circuits as GB to FC and IF valves, giving automatic volume control.

HT voltages for **V1** pentode and **V2** anodes and screens, and part of the AVC delay potential, are obtained from the potential divider **R6**, **R7**, **R8**, **R9** across the HT circuit, **V3** cathode current flowing through **R9**. GB for **V3** triode is obtained from the drop along **R15**, which, together with the drop along **R9**, biases **V3** cathode to provide AVC delay. **V3** triode CG circuit is therefore returned for DC to the bottom of **R15**, but for AC it is returned via **C15** to cathode.

Current to **V1** pentode and **V2** anodes passes through a milliammeter type of instrument which operates as tuning indicator, the needle moving towards maximum (signal) as the current through the winding falls.

Resistance-capacitance coupling by **R19**, **C19** and **R20** between **V3** triode and directly heated large triode output valve (**V4**, Ferranti LP4), with a special coupling transformer **T1** for the treble region of the audio frequency scale. The component values are so chosen as to give a good overall frequency response, which can be varied to suit the user by the variable tone control **R18**, **C18**.

Provision is made for the connection of a low impedance external speaker across the secondary winding of the internal speaker input transformer **T2**, while

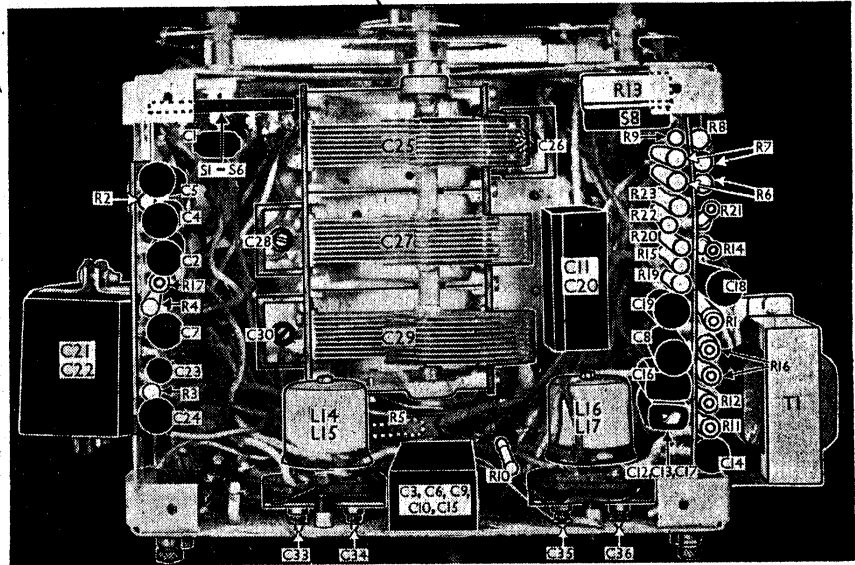

Under-chassis view. Most of the small components are mounted on two panels running along either side of the chassis. The arrangement of the resistors on the right-hand panel may be modified slightly in some chassis. A diagram of the **S1-S6** switch unit appears overleaf. **R5** is enclosed in sleeving.

S7 permits the internal speaker to be muted if desired.

HT current is supplied by full-wave rectifying valve (**V5**, Ferranti R4). Smoothing by speaker field **L20**, in the negative HT lead to chassis, and electrolytic capacitors **C21**, **C22**. GB for **V4** is

obtained from the junction of resistors **R22** and **R23**, which form a potential divider across **L20**, **V4** heater (cathode) being returned to chassis via the heater winding centre-tap on the mains transformer **T3**, while the control grid circuit is returned to the junction of **R22** and **R23** via **R20**, **R21**. Mains RF filtering by **C23**. Provision for mains aerial coupling via **C24** by tag **Y**, which can be attached to the aerial terminal of the receiver.

COMPONENTS AND VALUES

CAPACITORS		Values (μF)
C1	Aerial top coupling ...	0.000018
C2	Part band-pass coupling ...	0.05
C3	V1 pent. anode decoupling ...	0.1
C4	V1 cathode by-pass ...	0.02
C5	Image rejector LV shunt ...	0.02
C6	V2 anode decoupling ...	0.1
C7	Osc. reaction coupling ...	0.01
C8	V2 CG decoupling ...	0.05
C9	V1, V2 SG's decoupling ...	0.1
C10	V2 cathode by-pass ...	0.1
C11*	V3 cathode by-pass ...	1.0
C12	} IF by-pass capacitors ...	0.00015
C13		0.00015
C14		0.01
C15	AF coupling to V3 triode ...	0.25
C16	V3 triode CG decoupling ...	0.0005
C17	V3 AVC diode coupling ...	0.0003
C18	Part variable tone control ...	0.05
C19	AF capacitance coupling ...	0.02
C20	V4 CG decoupling ...	0.25
C21*	} HT smoothing capacitors ...	8.0
C22*		8.0
C23	Mains RF by-pass ...	0.002
C24	Mains aerial coupling ...	0.002
C25†	Band-pass pri. tuning ...	—
C26†	B-P pri. MW trimmer ...	—
C27†	Band-pass sec. tuning ...	—
C28†	B-P sec. MW trimmer ...	—
C29†	Oscillator circuit tuning ...	—
C30†	Osc. circ. MW trimmer ...	—
C31†	Osc. circ. MW tracker ...	—
C32†	Osc. circ. LW tracker ...	—
C33†	1st IF trans. pri. tuning ...	—
C34†	1st IF trans. sec. tuning ...	—
C35†	2nd IF trans. pri. tuning ...	—
C36†	2nd IF trans. sec. tuning ...	—

* Electrolytic. † Variable. ‡ Pre-set.

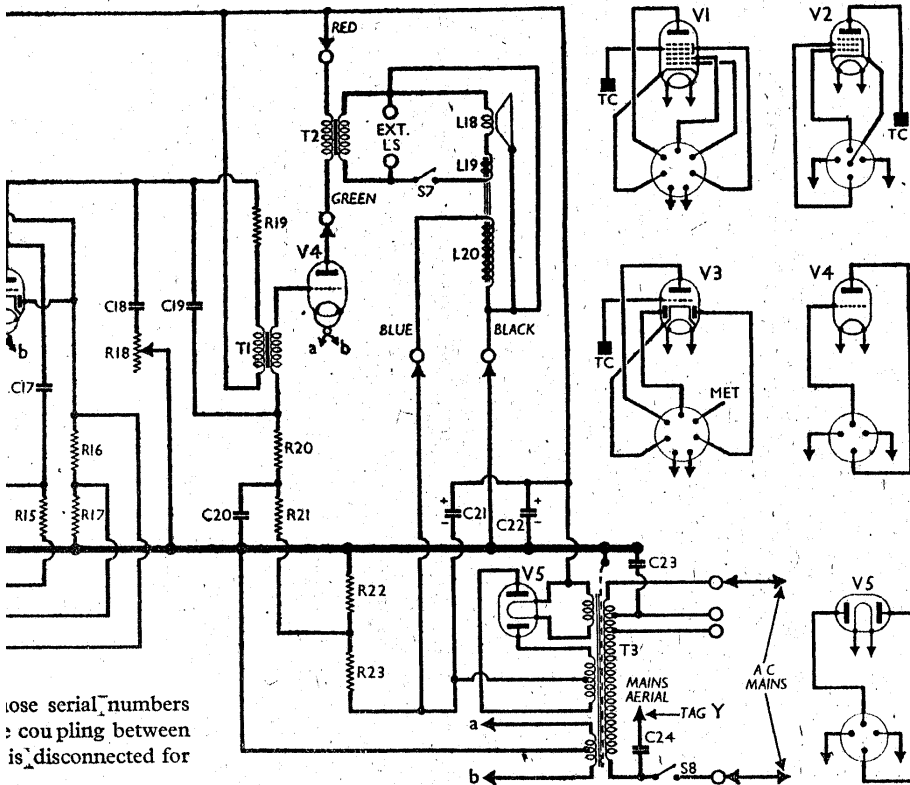

lose serial numbers
coupling between
is disconnected for

RESISTORS		Values (ohms)
R1	V1 CG decoupling ...	1,000,000
R2	V1 fixed GB resistor ...	300
R3	V1 pent. anode decoupling ...	1,000
R4	V1 osc. CG resistor ...	50,000
R5	V1 osc. anode HT feed ...	100,000
R6	V1 pentode and V2 HT feed and AVC delay potential divider ...	3,000*
R7		9,000†
R8		13,000
R9	V2 fixed GB resistor ...	450
R10	IF stopper ...	100,000
R11	V3 signal diode load ...	500,000
R12	Manual volume control ...	1,000,000
R13	V3 triode CG decoupling ...	100,000
R14	V3 triode GB resistor ...	1,700
R15	V3 AVC diode load ...	4,000,000‡
R16		1,000,000
R17	Variable tone control ...	500,000
R18	V3 triode anode load ...	40,000
R19	V4 CG resistor ...	250,000
R20	V4 CG decoupling ...	60,000
R21	V4 GB potential divider ...	100,000
R22		250,000
R23		

* Consisting of two 6,000 Ω resistors in parallel.
† Consisting of two 18,000 Ω resistors in parallel.
‡ Consisting of two 2,000,000 Ω resistors in series.

OTHER COMPONENTS		Approx. Values (ohms)
L1	Aerial coupling coils ...	17.5
L2		68.0
L3	Band-pass primary coils ...	5.0
L4		41.0
L5	Image rejector coil ...	1.7
L6	Band-pass coupling coils ... (Part L9)	0.2
L7		5.0
L8	Band-pass secondary coils ...	4.0
L9		24.5
L10	Osc. MW tuning coil ...	6.5
L11	Osc. LW tuning coil ...	3.2
L12	Osc. reaction coils ...	120.0
L13		120.0
L14	1st IF trans. { Pri. ...	120.0
L15		120.0
L16	2nd IF trans. { Pri. ...	120.0
L17		120.0
L18	Speaker speech coil ...	4.0
L19	Hum neutralising coil ...	0.5
L20	Speaker field coil ...	1,600.0
T1	Intervalve trans. { Pri. ...	30.0
T2		490.0
T2	Speaker input { Pri. ...	250.0
T3		0.3
T3	Mains Heater sec. ...	40.0
TI		0.05
TI	Tuning indicator winding	0.1
S1-S6		470.0
S7	Waveband switches ...	—
S8	Internal speaker switch ...	—
S8	Mains switch, ganged R13	—

VALVE ANALYSIS

Valve voltages and currents given in the table below are those quoted by the makers. They represent values to be expected in an average chassis when the receiver is working with the voltage adjustment properly set, with the receiver tuned to 200 m, the volume control at maximum, but with no signal input.

Voltages should be measured with a high-resistance meter whose negative lead is connected to chassis.

Valve	Anode Voltage (V)	Anode Current (mA)	Screen Voltage (V)	Screen Current (mA)
V1 VHT4†	168	1.7	82	4.0
	Oscillator	1.4		
V2 VPT4	62	3.3	82	2.0
V3 H4D‡	145	1.7	—	—
V4 L4D	230	46.0	—	—
V5 R4 §	350†	—	—	—

† Each anode, AC.

DISMANTLING THE SET

Removing Chassis.—Remove the four control knobs below the scale (pull-off), and the small one above it (recessed grub screw);

withdraw the four speaker leads from their pins on the front of the connecting panel on the mains transformer; remove the four screws (with large claw washers) holding the chassis to the bottom of the cabinet.

When replacing, connect the speaker leads as follows, using only the upper row of pins which face towards the front of the cabinet, as follows, numbering the pins from left to right when viewed from the rear: 1, blue; 2, green; 3, red; 4, black.

Small pads of sponge rubber should be fitted between the chassis and the bottom of the cabinet.

Removing Speaker.—Remove the four nuts from the bolts holding the speaker to the sub-baffle, and withdraw the leads from their pins.

When replacing, the transformer should be at the top, and the leads should be connected as described previously.

If the leads have been unsoldered from their connecting tags on the transformer, they should be connected as follows, numbering the tags from left to right as seen from the rear: 1, blue; 2, red; 3, green; and 4, at the foot of the transformer, black (earthing lead).

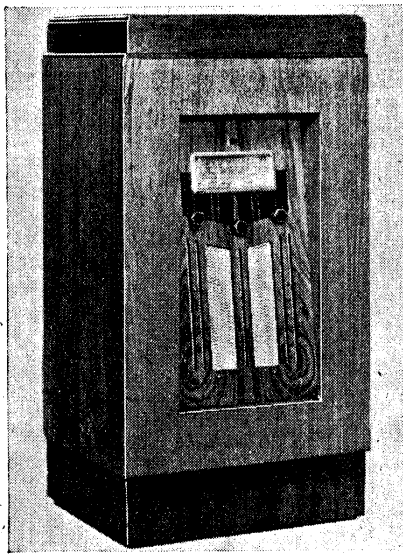

The appearance of the 1934-5 Arcadia diagram, which has an inclined speaker mounting. A 3/1 pick-up transformer is fitted.

GENERAL NOTES

Switches.—S1-S6 are the waveband switches, ganged in a single two-position rotary unit beneath the chassis. This is indicated in our under-chassis view, and shown in detail in the diagram in col. 4, where it is drawn as seen when viewed from the rear of the underside of the chassis.

The table (next col.) gives the switch position for the two control settings: MW

(anti-clockwise position of the control knob) and LW (clockwise position). A dash indicates open, and C, closed.

Switch Table

Switch	MW	LW
S1	C	—
S2	C	—
S3	C	—
S4	—	C
S5	C	—
S6	C	—

S7 is the internal speaker muting switch, mounted on the speaker assembly and having a long control spindle so that the knob is accessible from the rear of the cabinet. The switch opens in the anti-clockwise position of the control knob.

S8 is the QMB mains switch, ganged with the volume control R13.

Coils.—L1-L5; L6-L9; and L10-L13 are the aerial, band-pass and oscillator coils, in three screened units on the chassis deck. The oscillator unit also contains the two associated trackers C31, C32, whose adjustments project from the top of the can. The IF units L14, L15 and L16, L17 are beneath the chassis on the rear member, through which their tuning adjustments are reached. The units each have a screening cover which is held by a single nut, and the tuning capacitors are inside the units.

Scale Lamps.—These are two Osram MES type lamps rated at 2.5 V, 0.3 A. They are connected in series across the LT secondary winding of the mains transformer, which is centre-tapped, and their mutual junction is taken to chassis also.

Gramophone Pick-up.—Two screw terminals are provided on the rear member of the chassis, on the right when viewed from the rear, for the connection of a gramophone pick-up. With normal magnetic pick-ups, an input transformer with a ratio of about 3/1 will be required between the terminals and pick-up respectively. Radio is muted by the removal of the tag X from the upper (high potential) terminal, but this must be replaced to receive radio signals, as it forms the connection between the diode circuit and the volume control.

External Speaker.—Two screw terminals are provided on the speaker assembly for the connection of a low-impedance (about 4.6 Ω) external speaker. Switch S7, mounted just above the terminals, permits the internal speaker to be muted if desired.

Capacitors C3, C6, C9, C10, C15.—These are all paper-insulated capacitors in a single multiple block beneath the chassis on the rear member. The unit has a metal case which is connected to chassis. One side each of C3, C6, C9 and C10 goes to the case, the other side of each being connected to a red lead, four of which emerge from one end of the unit. The two yellow leads with them are the connections to C15, which is isolated from chassis. C15 is 0.25 μF; the other four are all 0.1 μF.

Capacitors C11, C20.—These are two capacitors in another single metal-cased unit. C11 is a 1 μF (50 V peak) electrolytic, and C20 is a paper-insulated 0.25 μF type. Both are connected on the nega-

tive side to the case, while the other side (positive) of **C11** has a red outlet lead, and the other side of **C20** a yellow lead.

Capacitors C12, C13, C17.—These are the three IF by-pass capacitors mounted beneath the chassis near **V3** holder. Although they are actually three separate capacitors, they are tied together and waxed, so that they form a single triple unit. The bottom tag, visible in our under-chassis view, is the common connection to the cathode, and three tags project from the other end.

Capacitors C21, C22.—These are the two HT smoothing electrolytics mounted in a clamp which is screwed to the side of the chassis. Both are rated at 8 μ F, 500 V peak, and are contained in a Ferranti single unit type CE100. Each has its own red and black outlet leads, which are taken to the speaker connections on the panel on the mains transformer **T1** in the centre of the chassis deck, the two red leads going to the same pin (marked Red in our plan view). The black leads go to the pins marked Blue and Black. At one time, this unit was mounted in a clamp on the speaker assembly, but this occurred only in a few chassis.

Control Indicators.—In addition to the scale pointer and tuning indicator needle, there are three other indicators on the scale which show the positions of the waveband, tone and volume controls. These are spring loaded and operated by cords which pass round collars on the three control spindles.

Adjustment of these indicators is a simple matter of turning the collar, after slackening its fixing screw, on the appropriate control spindle, then tightening up the screw again. Adjustment is facilitated if the control is first turned to one end or the other of its range.

Wartime VHT4 Replacement.—As the design of the VHT4 has had to be modified slightly to suit wartime production, replacement of **V1** may result in some instability. This is recognised by intermittent hissing, with fierce oscillation at the upper end of the MW band.

This trouble can be remedied in the Arcadia most easily by so arranging the switching that **C7** is disconnected on MW, but reconnected on LW, and the makers recommend that switch **S4** be used for the purpose as follows.

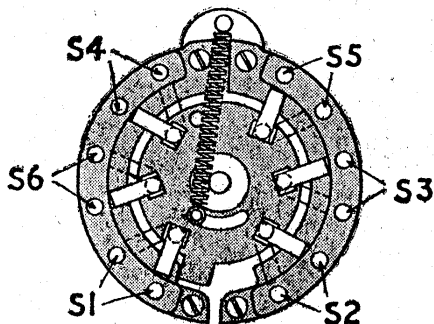
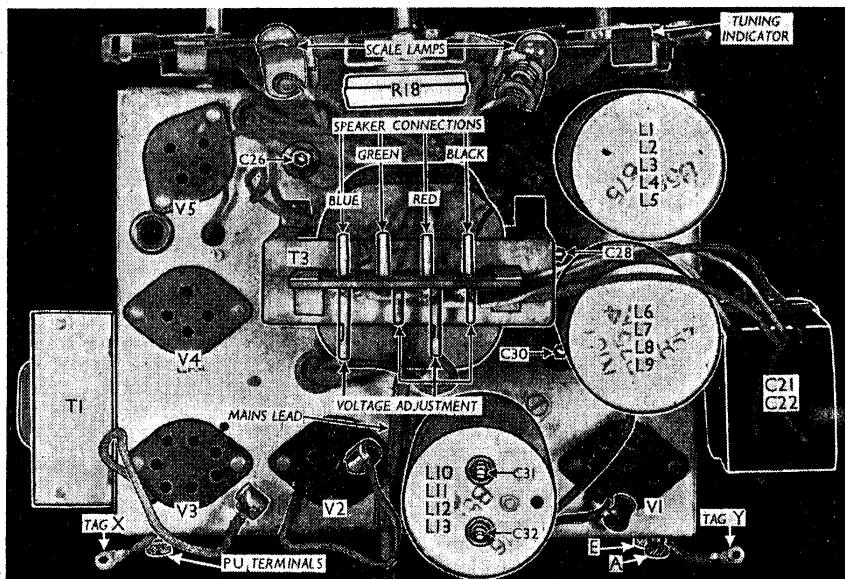

Diagram of the waveband switch unit **S1-S6**, drawn as seen when viewed from the rear of the underside of the chassis.



Plan view of the chassis. A panel mounted on the mains transformer carries four pins (on the front) for the speaker connections, and four more pins (on the rear) for mains connection and voltage adjustment. All the associated leads are terminated in tubular sleeves. **C21, C22**, the electrolytic block, may be mounted on the speaker assembly.

Disconnect one end of **C7**, and take two leads, one from each side of the disconnection, to the two tags of **S4**, removing the two leads already soldered to them. As **S4** closes on LW, **C7** will be out of circuit on MW.

CHASSIS DIVERGENCIES

Apart from the possibility that the electrolytic block **C21, C22** may be mounted on the speaker instead of on the chassis, as mentioned earlier, **C4** may be 0.03 μ F instead of 0.02 μ F, and the return lead from **L15** to the AVC line may go to the AVC line for **V1** instead of going to a different position at the junction of **R16** and **R17** as shown in our circuit diagram. Also, the sequence of the resistors on the assembly on the right-hand side of our under-chassis view might in some cases be a little rearranged.

There is, in addition, a modified chassis, in which the potential divider **R6, R7, R8, R9** is omitted. In this version, the HT feed to **V1** pentode and **V2** anodes is direct from the main HT positive line, as it would be in our diagram if **R6** were short-circuited. The HT feed to **V1** and **V2** screens is then also taken from the main HT positive line, via a 25,000 Ω feed resistor. In order to obtain the additional AVC delay potential previously taken from this potential divider, the junction of **R14** and **R15** is taken to chassis via a 35,000 Ω resistor.

These chassis may be identified by their serial number, which will be between 200,000 and 210,000. The serial numbers of the original version, on a sample of which this *Service Sheet* was prepared, run from 54,000 to 69,999.

CIRCUIT ALIGNMENT

The whole process of circuit alignment can be carried out without removing the

chassis from its cabinet. In any case, although trimmer adjustments on the gang are accessible from above or below the chassis, they should be adjusted from above, where a clockwise motion decreases their capacitance. All the adjustments require a specially shaped tool to fit the flat-sided screw-heads. The lock-nuts should be released before each adjustment, and locked after it, while still holding the adjustment with the trimming tool.

IF Stages.—Connect signal generator leads to control grid (top cap) of **V1** and chassis, and turn the volume control to maximum. Feed in a 125 kc/s (2,400 m) signal, and adjust **C36, C35, C34** and **C33** for maximum output.

RF and Oscillator Stages.—With the gang at minimum, the pointer should cover the 200 m mark on the scale. Leave the signal generator connected as for IF stages.

MW.—Switch set to MW, tune to 228 m on scale, feed in a 228 m (1,316 kc/s) signal, and screw up (anti-clockwise from above) **C30** fully. Then unscrew **C30** (clockwise) until the second peak is reached, and adjust on that for maximum output.

Transfer signal generator leads, via a dummy aerial (a 0.0002 μ F capacitor will do) to **A** and **E** terminals, still feeding in a 228 m signal, and adjust **C26** and **C28** for maximum output. Feed in a 500 m (600 kc/s) signal, tune it in, and adjust **C31** for maximum output while rocking the gang for optimum results.

LW.—Switch set to LW, feed in a 1,807 m (166 kc/s) signal, tune it in, and adjust **C32** for maximum output while rocking the gang for optimum results. Finally, check calibration at 1,128 m (266 kc/s).