

COPYRIGHT

This Service Data is for the information of Ekco Appointed Dealers only and must not be copied.

# EKCO SERVICE DATA

## MODEL U195

See also Service News Sheets Nos:

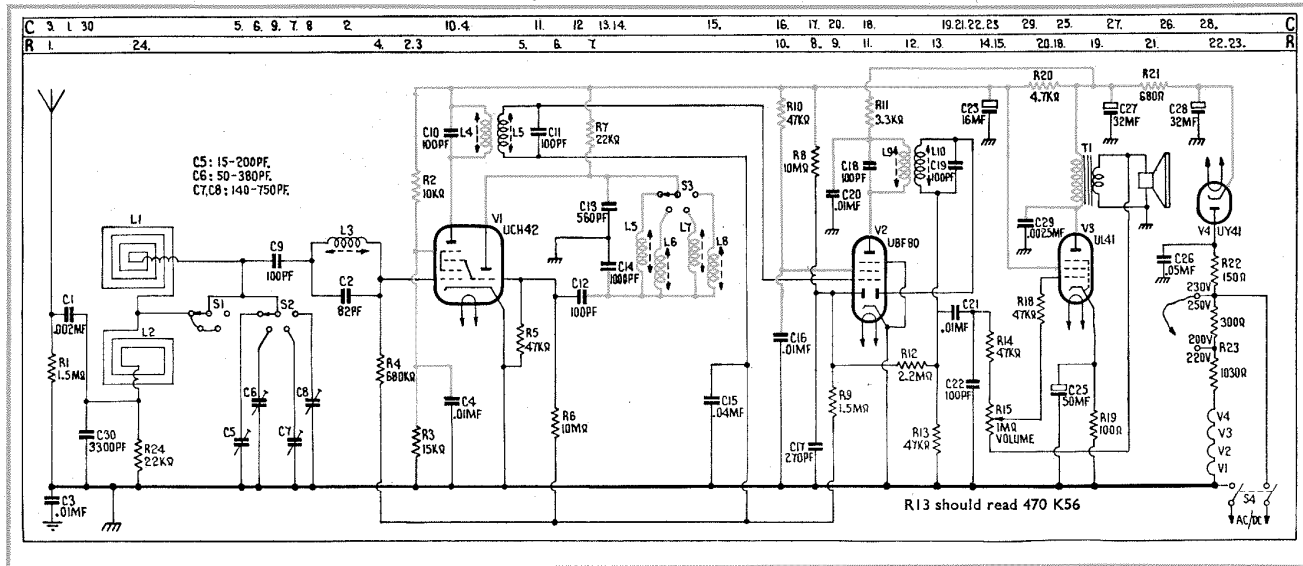

**MODEL U195** is a four-valve, A.C./D.C. receiver offering switch-controlled selection of three M.W. and one L.W. stations. Built-in frame aerials are included for both M.W. and L.W. reception, and to cater for areas of low field strength, sockets are provided for the connection of an external aerial and earth.

**CAUTION :** As is customary with A.C./D.C. receivers, the chassis connects to one side of the mains supply, and care must be taken to ensure that chassis is to the earthed side of the mains. Test with a neon lamp and insulated leads between chassis and a good earth. If the lamp glows, reverse the mains input.

For the reason given above, adjustment of the station pre-selector keys must only be made with the insulated tool provided with each receiver.

**CONTROLS :** Upper—VOLUME. Lower—SELECTOR SWITCH.

**MAINS SUPPLY :** 200-250 volts D.C. or 200-250 volts 40-100 c.p.s. A.C.

**CONSUMPTION :** 42 watts with 230 volts A.C. input.  
34 watts with 230 volts D.C. input.

**MAINS ADJUSTMENT :** Refer to diagram of mains resistor R22, R23. For 230/250V, connect the link to B, and for 200/220V, connect link to C. For 110V, connect B to D, then A to B. Tags E and F may also be connected together, but this will cause a rise in hum level on A.C.

**VALVES.** V1—UCH42—Frequency changer. V2—UBF80—I.F. amplifier, demodulator, AVC. V3—UL41—A.F. amplifier. V4—UY41—Half-wave rectifier. All are MULLARD. V1, V3, V4 have B8A bases. V2 has a noval (B9A) base.

**LOUD-SPEAKER IMPEDANCE :** 3 ohms at 400 c.p.s.

**INTERMEDIATE FREQUENCY :** 470 Kc/s.

**PRE-SET COVERAGES :**

1. 1600—875 Kc/s. 188—343 Metres.
2. 1230—685 Kc/s. 244—438 Metres.

**PRE-SET COVERAGES—continued**

3. 965—540 Kc/s. 311—555 Metres.
4. 250—160 Kc/s. 1200—1875 Metres.

**CIRCUIT DETAILS :** In the aerial and earth circuits are protective capacitors C1, C3, and a static leak R1 is provided for use with external aerials. Both frame aerials are in series for L.W. operation, with L1 short-circuited on M.W., the loop in use being shunted by the appropriate trimmer for the range selected. Signals from the tuned circuit so formed feed via C9 and an I.F. filter to V1 control grid.

A Colpitts oscillator circuit is used, being completed by the connection of the appropriate coil by the selector switch. Each coil is tuned by an iron dust core. The I.F. output of V1 is transformer coupled to the pentode section of V2, amplified, then transformer coupled to one diode of V2 for demodulation. The bulk of the A.F. output, developed across R13, feeds via C21, R14, R15 and R18 to the A.F. amplifier V3, the output of which is transformer coupled to the P.M. loud-speaker.

Negative feedback is applied from the speaker circuit to V3 grid via R15, R18. AVC, delayed by a set potential from the divider formed by R8, R12, R13, is developed by the second diode of V2, driven from the demodulated A.F. via R12. The output is fed to V1 and V2 control grids. The power circuits are conventional, H.T. being derived from the mains voltage via a half-wave rectifier, and the heaters in series with a ballast resistor across the mains.

**CIRCUIT ALIGNMENT :** Turn selector switch to range 3. Connect an output meter across the secondary of the output transformer. Set the volume control to maximum output.

Inject a modulated 470 Kc/s signal via a 0.1 mfd capacitor to the control grid (pin 6) of V1, then adjust the four I.F. cores in the following order for maximum output. 2nd I.F.T. upper and lower, then 1st I.F.T. upper and lower. Inject the 470 Kc/s to the aerial socket then adjust L3 core for minimum output.

**STATION SETTING :** A weak signal should be used in order to obtain a correct setting of the oscillator core, and an external aerial should therefore be disconnected. The set should be rotated slightly to reduce signal pick-up as the oscillator adjustment nears the correct setting.

Turn the selector switch to the required range. Adjust the appropriate oscillator core for maximum output (see above) and the adjacent aerial trimmer for resonance.

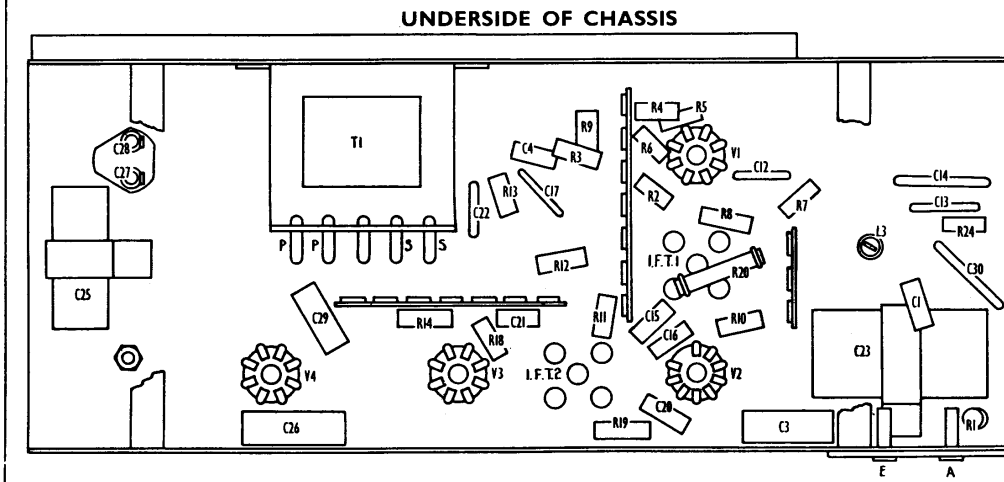
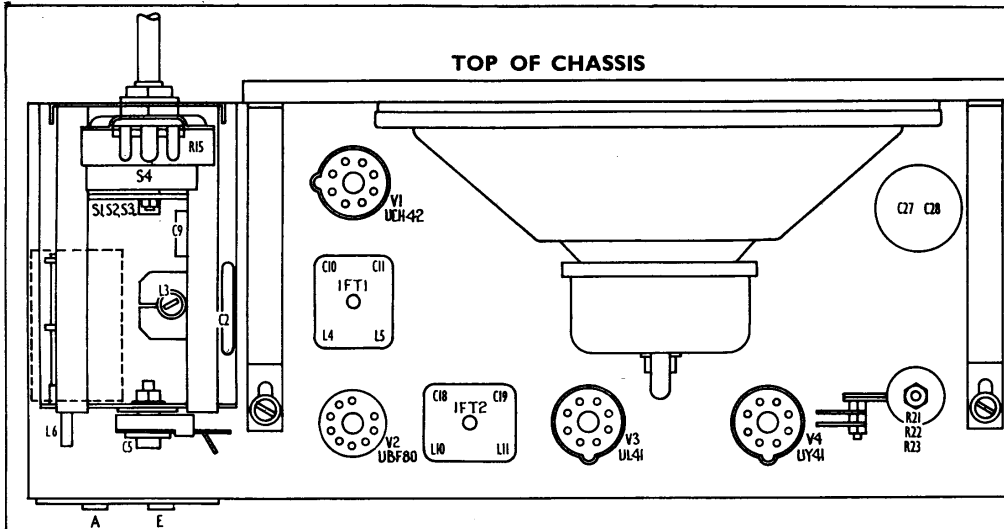

**FRAME AERIAL CONNECTIONS**

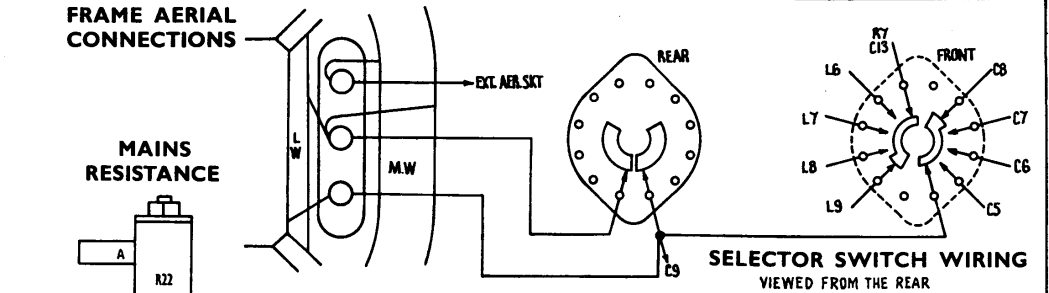

**MAINS RESISTANCE**

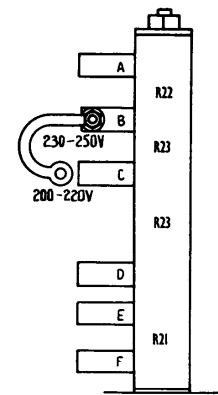

**VALVE BASE DATA**

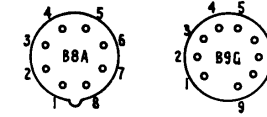

**RESISTANCE OF WINDINGS**

WINDING	OHMS	WINDING	OHMS
L1		L8	2.0
L2		L9	2.3
L3	1.0	L10	15.0
L4	15.0	L11	15.0
L5	15.0	PTI	215.0
L6	1.5	T1	0.3
L7	1.8		

**VOLTAGE AND CURRENT DATA**

VALVE	ANODE		SCREEN		CATHODE	
	V	M.A.	V	M.A.	V	M.A.
V1 MIXER	106	2.1	53	2.2	0	6.3
V1 OSC.	62	2.0				
V2	179	3.2	50	1.2	0	4.4
V3	180	42.2	106	6.3	4.7	48.5
V4	229V A.C.				233	63.0

Conditions : Set tuned to Range 2. No signal input.  
Volts relative to chassis. D.C. volts with 20,000 ohms/volt meter. A.C. volts with 1,000 ohms/volt meter.  
240 volts 50 c.p.s. mains input.

**VALVE BASE DATA**

VALVE	1	2	3	4	5	6	7	8	9	
UCH42	H	A	OA	OG	SG	G1	K	H		B8A
UBF80	G2	G1	K.S.	H	H	A	D1	D2	G3	B9A
UL41	H	A			G2	G1	K.G3	H		B8A
UY41	H	A					K	H		B8A

**COIL & SWITCH UNIT**

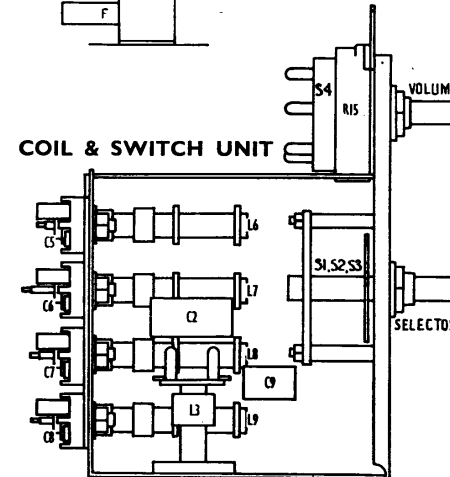

**SERVICE DEPT., E. K. COLE Ltd.,**  
Somerton Works, Arterial Road,  
Southend-on-Sea  
Phone: Southend 2296  
Head Office: Ekco Works, Southend-on-Sea

**SCOTTISH SERVICE DEPOT:**  
26, India Street,  
Glasgow, C.2.  
Phone: Central 2012

**NORTHERN SERVICE DEPOT:**  
55, Whitworth Street,  
Manchester, 1  
Phone: Central 6711/2

**MIDLAND SERVICE DEPOT:**  
11, Brook Street,  
Birmingham, 3  
Phone: Central 2505/6

C	3	1	30	5	6	9	7	8	2	10.4	11	12	13.14	15	16	17	20	18	19.21	22.23	29	25	27	26	28	C
R	1	24		4	2.3					5	6	7			10	8	9	11	12	13	14.15	20.18	19	21	22.23	R

