

model P28

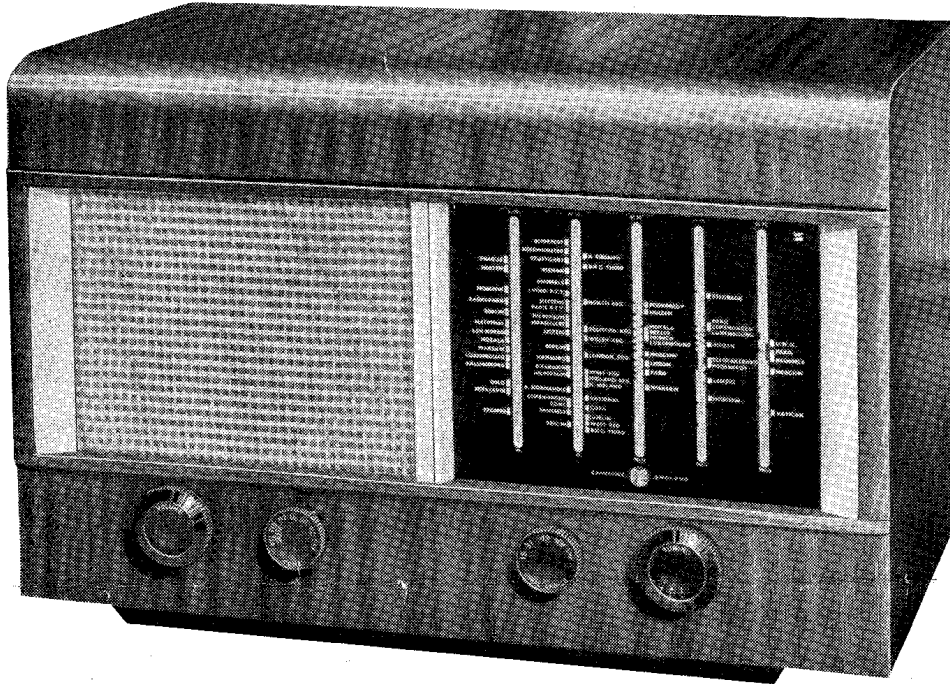

FOR OPERATION
OFF 200/250 V.
A.C. MAINS

CIRCUIT ANALYSIS

Mains consumption 47 watts. Unsmoothed H.T. 305 v. Smoothed H.T. 255 v.										
	Valve	Mullard	Ea	Ia	Es	Is	Osc.			
							Ea	Ia	Ec	Ic
V1	Frequency Changer	ECH.35	255	3.6	90	2.6	126	5.5	2.5	11.7
V2	I.F. Amplifier	EF.22	255	6.2	90	2.0	—	—	2.7	8.2
V3	Det., A.V.C. and Output Stage ..	EBL.31	240	26	255	3.5	Bias volts 6.5		19.0	29.5
V4	Power Rectifier	AZ.31	285-0-285 A.C.						305	—

Note.—Set on L.W. with Gang Condenser fully meshed. No signal input. Mains input voltage 200 v. into 200/215 v. tap. Measurements taken with an Avometer Model 7 instrument.
All voltages over 10 v. taken on 400 v. range.
All voltages under 10 v. taken on 10 v. range.

TRIMMING PROCEDURE

Apply signal as below	Tune receiver to	Adjust in order for maximum output
(1) 465 kc/s. via 0.1 μ F condenser between Earth Terminal and Control Grid of V1. Grid lead to remain connected	Low frequency end of L.W. band. Gang Condenser fully meshed. Pointer aligned with spots at top of tracks	Iron dust cores of T2 and T1
(2) 225 kc/s. (1333 metres) via Dummy Aerial between Aerial and Earth Terminals	L.W. 1333 metres	Iron dust cores of L6 and L2
(3) As (2) but 600 kc/s. (500 metres)	M.W. 500 metres	Iron dust cores of L7 and L1
(4) As (2) but 1500 kc/s. (200 metres)	M.W. 200 metres	Trimmer C16 and C4
(5) Repeat (4) and (5) until calibration and tracking are correct		
(6) As (2) but 6.1 Mc/s.	49 M. band 6.1 Mc/s.	Iron dust cores of L8 and L3
(7) As (2) but 9.6 Mc/s.	31 M. band 9.6 Mc/s.	Iron dust cores of L9 and L4
(8) As (2) but 17.8 Mc/s.	16 M. band 17.8 Mc/s.	Iron dust cores of L10 and L5

CALIBRATION CHART

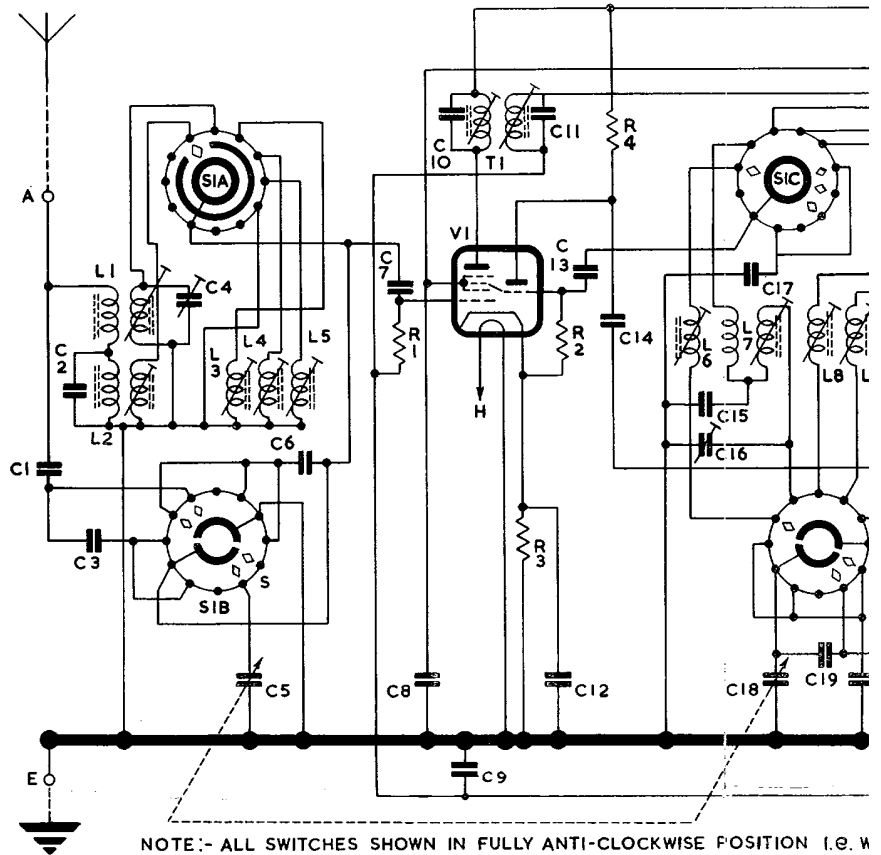
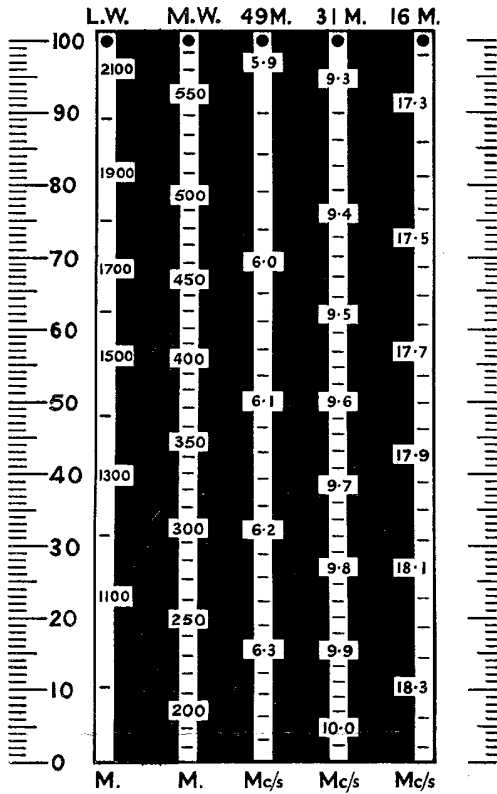

NOTE:- ALL SWITCHES SHOWN IN FULLY ANTI-CLOCKWISE POSITION I.E. W ALL SWITCHES VIEWED FROM FRONT & DIRECTION OF ROTATION I

circuit diagram of the **PYE MODEL P28**

fitting a new tuning scale

- 1** Remove chassis.
- 2** Place Scale Plate in cabinet aperture and screw clips tightly in position, first making sure that the scale is square with the cabinet aperture.
- 3** Fit chassis in cabinet.
- 4** Adjust Gang Condenser to maximum position and line up the pointer to the spots to be found at the top of the tracks.

CONDENSERS

	Specification	Fig.	No
C1	100 pF Ceramic	3	6665
C2	220 pF Mica	3	6664
C3	5.6 pF Ceramic	3	6666
C4	3-50 pF Trimmer	3	8000
C5	Gang Condenser	1 & 2	8000
C6	82 pF Mica	3	6662
C7	100 pF Ceramic	3	6665
C8	0.1 μF Tubular 500 v. .. .	3	6681
C9	0.05 μF Tubular	3	6681
C10	100 pF		
	+ Mica	± 2%	1 & 2
C11	100 pF		
C12	0.01 μF Tubular 350 v. .. .	3	6680
C13	100 pF Ceramic	3	6665
C14	100 pF Ceramic	3	6665
C15	560 pF Mica	3	6662
C16	3-50 pF Trimmer	3	8000
C17	200 pF Mica	3	6667
C18	Gang Condenser	1 & 2	8000
C19	68 pF Mica	3	6662
C20	130 pF Mica	3	6664
C21	100 pF		
	+ Mica	± 2%	1 & 2
C22	100 pF		
C23	0.1 μF Tubular 350 v. .. .	3	6680
C24	10 pF Ceramic	3	6665
C25	100 pF Ceramic	3	6665
C26	100 pF Ceramic	3	6665
C27	0.1 μF Tubular 150 v. .. .	3	6688
C28	0.1 μF Tubular 150 v. .. .	3	6688
C29	0.1 μF Tubular 150 v. .. .	3	6688
C30	0.01 μF Tubular 1000 v. .. .	3	6680
C31	0.005 μF Tubular 600 v. A.C. .. .	3	6681
C32	25 μF Electrolytic 25 v. .. .	3	6670
C33	32 μF		
	+ Electrolytic 450 v. .. .	1 & 2	6670
C34	32 μF		

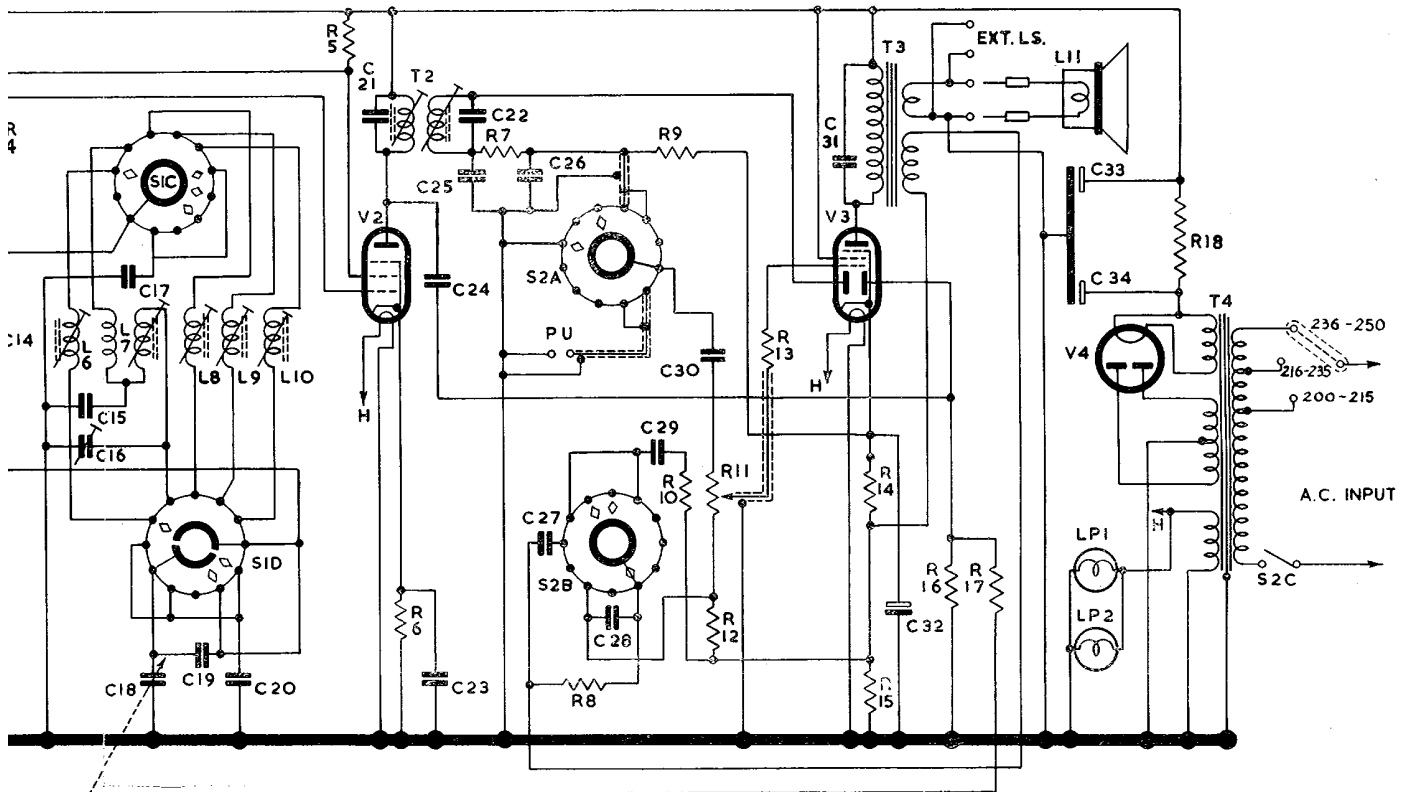

CLOCKWISE POSITION I.E. WAVE RANGE SWITCH ON LONG WAVES. TONE SWITCH IN OFF POSITION.
 DIRECTION OF ROTATION CLOCKWISE.

RESISTORS		INDUCTANCES	
Fig.	No.	Specification	Ref. Fig. No.
3	666520	L1	M.W. Aerial Coil M.W.10 3 780326
3	666419	L2	L.W. Aerial Coil L.W.6 3 780328
3	666659	L3	49 M. Aerial Coil S.W.11 3 780244
3	800076	L4	31 M. Aerial Coil S.W.5 3 780277
1 & 2	800023	L5	16 M. Aerial Coil S.W.2 3 780279
3	666231	L6	L.W. Osc. Coil L.W.1 3 780241
3	666520	L7	M.W. Osc. Coil M.W.9 3 780254
3	668127	L8	49 M. R.F. Coil S.W.9 3 780273
3	668125	L9	31 M. R.F. Coil S.W.7 3 780275
3	668125	L10	16 M. R.F. Coil S.W.4 3 780278
1 & 2	666440	L11	Loudspeaker 1 850007
3	668027		
3	666520		
3	666520		
3	666242		
3	800076		
3	666750		
1 & 2	800023		
3	666229		
3	666412		
1 & 2	666440		
3	668006		
3	666525		
3	666520		
3	668030		
3	668030		
3	668030		
3	668003		
3	668154		
3	667013		
1 & 2	667093		

RESISTORS		INDUCTANCES	
Fig.	No.	Specification	Ref. Fig. No.
3	670410	L1	M.W. Aerial Coil M.W.10 3 780326
3	670538	L2	L.W. Aerial Coil L.W.6 3 780328
3	670510	L3	49 M. Aerial Coil S.W.11 3 780244
3	670458	L4	31 M. Aerial Coil S.W.5 3 780277
3	670461	L5	16 M. Aerial Coil S.W.2 3 780279
3	670512	L6	L.W. Osc. Coil L.W.1 3 780241
3	670538	L7	M.W. Osc. Coil M.W.9 3 780254
3	670522	L8	49 M. R.F. Coil S.W.9 3 780273
3	670408	L9	31 M. R.F. Coil S.W.7 3 780275
3	670518	L10	16 M. R.F. Coil S.W.4 3 780278
3	810000	L11	Loudspeaker 1 850007
3	670522		
3	670392		
3	670510		
3	670438		
3	670410		
3	670410		
3	670834		

SWITCHES AND LAMPS		TRANSFORMERS	
Fig.	No.	Specification	Fig. No.
3	830256	T1	1st I.F. Trans. { Prim. 10Ω } 1 & 2 770345
3	830256	T2	2nd I.F. Trans. { Prim. 10Ω } 1 & 2 770342
3	830256	T3	Output Trans. { Prim. 456Ω } 2 770070
3	830255	T4	Mains Trans. { Feedback Sec. 96Ω } 1 & 2 770308
3	830255		
3	700494		

Note * Integral part of I.F. Transformers

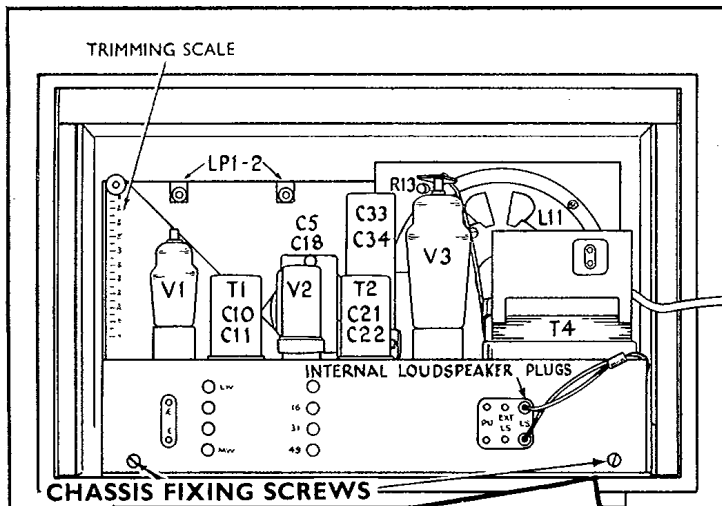

FIG. 1

TO REMOVE CHASSIS
1 PULL OFF KNOBS. **2** PULL OUT LOUDSPEAKER PLUGS. **3** REMOVE THE TWO CHASSIS FIXING SCREWS. **4** WITHDRAW CHASSIS APPROXIMATELY TWO INCHES, TIP UP AND LIFT OUT.

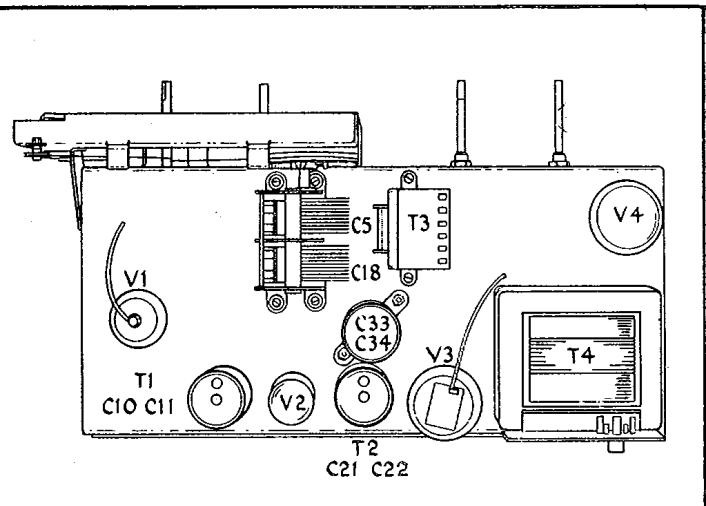

FIG. 2

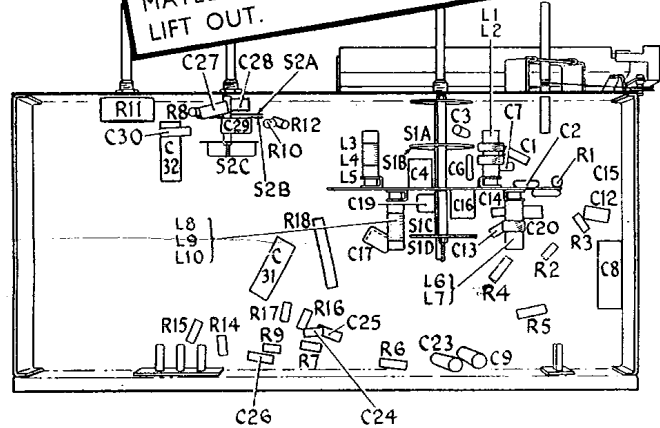
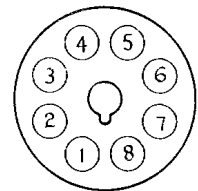

FIG. 3

VALVE BASE CONNECTIONS

	1	2	3	4	5	6	7	8	Top Cap
V1	M	H	AH	G2 G3	GT G3	AT	H	K	G1
V2	H	A	G2	G3	—	G1	K	H	—
V3	M	H	A	D1	D2	G2	H	K G3	G1
V4	—	H	—	A1	—	A2	—	H	—



VIEW LOOKING AT PINS

FIG. 4

THE DRIVE CORD SHOULD BE OF NYLON BRAIDED GLASS YARN. LENGTH 28 3/4 BETWEEN CENTRES OF LOOPS.

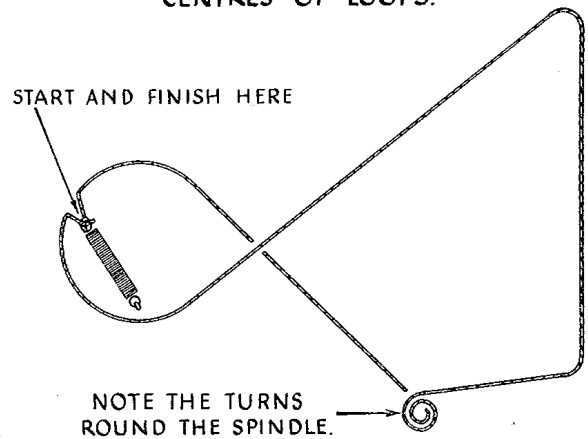
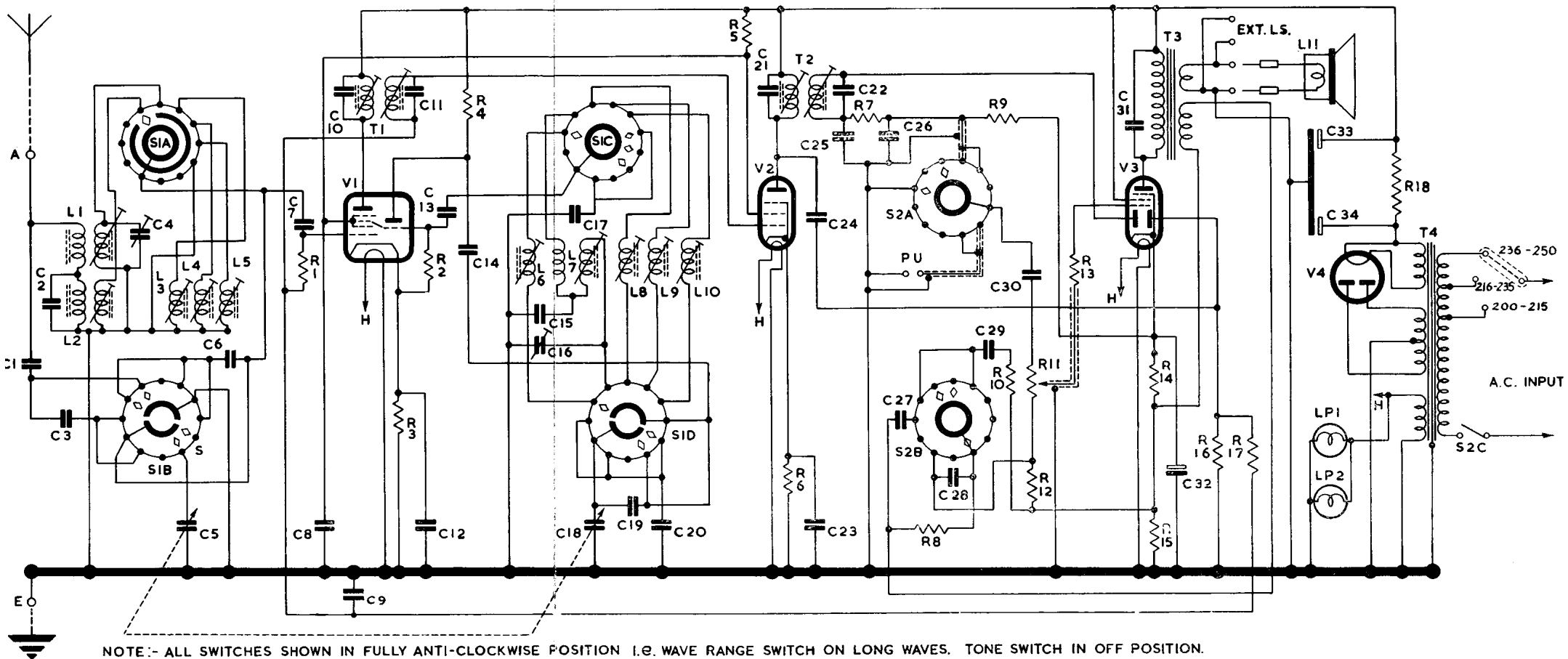

FIG. 5

Notes

- 1 The Pye Quick Release (Patent No. 601,920) permits the removal of chassis without turning the cabinet over. See Fig. 1.
- 2 The Special Flywheel Tuning needs no maintenance.
- 3 New design Aerial Circuit and Coils gives reduced image response and greater freedom from whistle.
- 4 A 100 division Trimming Scale is printed on the back of the scale reflector plate for use when trimming the receiver outside the cabinet. See Fig. 1.
The top of the pointer carriage serves as an index for the scale.
A Calibration Chart is printed on page 2.
When no accurate frequency standard is available the receiver should be calibrated against a reliable broadcasting station operating at a frequency close to that specified in the trimming instructions.
- 5 External Speaker, 2-4 ohms impedance.
- 6 Dial Bulbs 6.5 volt 0.3 amp. M.E.S.
- 7 Make sure Mains Voltage Selector is in correct position to ensure (a) maximum valve and component life and (b) full benefit of the Pye "FIDELITY" reproduction.



NOTE:- ALL SWITCHES SHOWN IN FULLY ANTI-CLOCKWISE POSITION I.E. WAVE RANGE SWITCH ON LONG WAVES. TONE SWITCH IN OFF POSITION.
 ALL SWITCHES VIEWED FROM FRONT & DIRECTION OF ROTATION CLOCKWISE.