

**SIX** transistor personal radio with leather carrying case, released October, 1960, at 14½gns. Case and earpiece, 35s. extra.

**Battery.** Ever Ready PP4 or equivalent.

**Consumption.** 45mA at 200mW output.

**Wavebands.** MW, 190-490m ; LW, 1,500m preset (Light).

**Transistors.** OC44, OC45 (2), OC78D, OC78 (2).

**Diode.** OA70.

**IF.** 470kc/s.

**Output.** 250 mW.

**Speaker.** 3in. round, 3 ohms.

**Aerial.** 6 in. ferrite rod.

**Manufacturer.** Dynatron Radio, Ltd.

**Service department.** St. Peter's Road, Furze Platt, Maidenhead, Berks.

### DISMANTLING

**Chassis removal.** Remove rear cover by unscrewing retaining screw with a coin ; then unscrew centre of tuning knob with a suitable two-pronged tool such as a pair of tweezers, while holding plastic section still. Remove both plastic parts of knob, revealing three 4BA screws fixing tuning capacitor to cabinet; when these are removed the chassis may be withdrawn from rear of case to extent of speaker

leads. When refitting rear cover ensure that lugs at battery end of case engage with slots in cover before tightening screws.

**Battery replacement.** Access to battery compartment is gained by removing back cover as for chassis removal. Take care to re-connect battery with correct polarity to avoid damage to transistors.

### SERVICE NOTES

**Voltages.** Readings shown on circuit are taken relative to earth line (positive).

**Circuit notes.** A printed circuit is employed

*Continued overleaf*



The Tourist TP14 is shown here with its leather carrying case, available as an extra

VT1 is a self-oscillating mixer with collector emitter feedback via tuned winding L5. Two IF stages VT2 and VT3 feed detector MRI which provides AGC via R6. Driver transistor VT4 feeds signal to output stages via transformer T1. Output transistors VT5 and VT6 feed up to 250mW to 3ohm speaker via T2. Neutralizing of IF stages is achieved by C16, 22 and R5, 10.

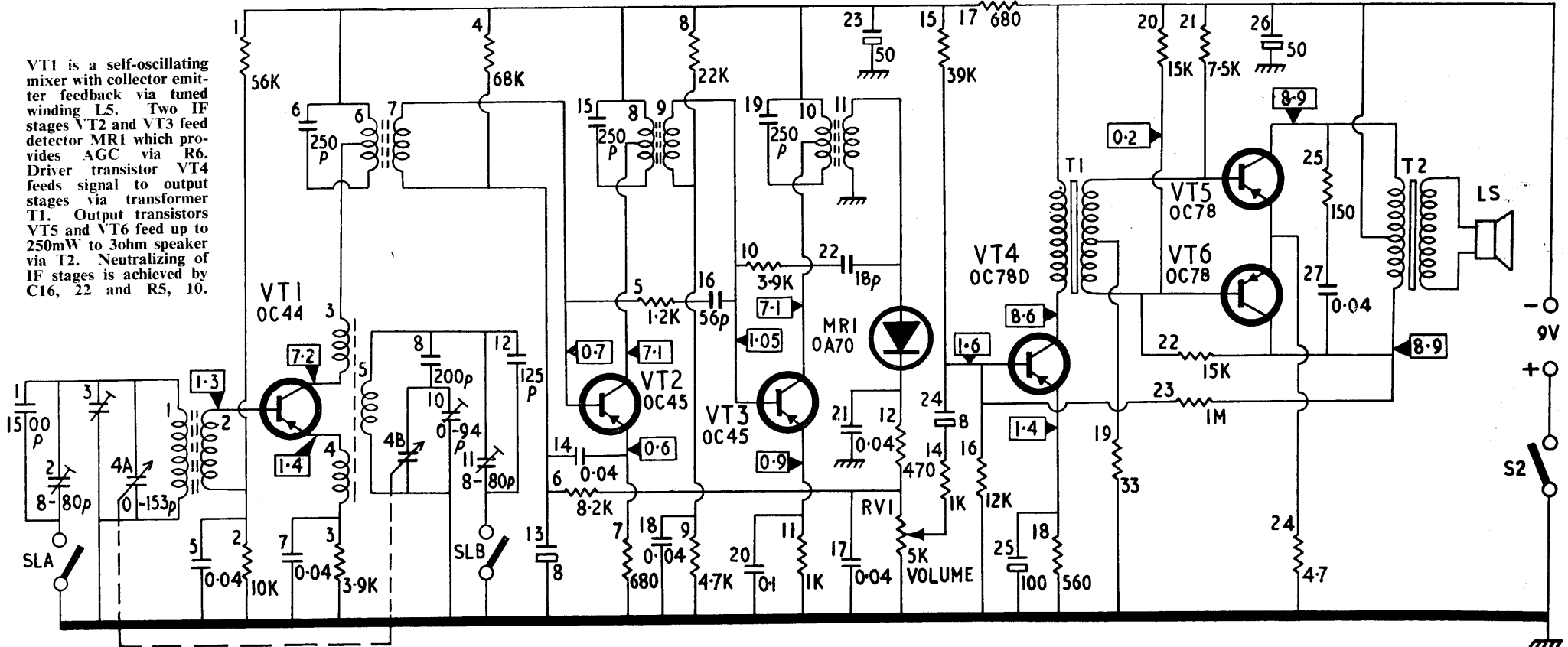

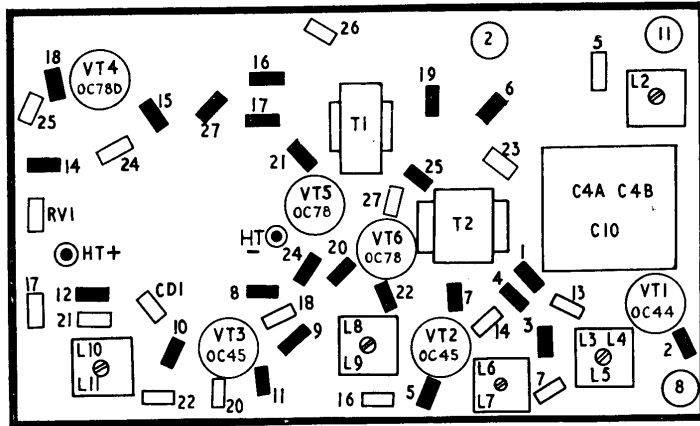

Component side of printed panel. Ganged condenser C4A/C4B is mounted with C4B nearest the panel; associated with C4B is its trimmer C10

in this receiver, and the normal precautions should be taken when using a soldering iron, particularly when working near a transistor.

When rotated fully anti-clockwise, the slow motion tuning drive operates S1 for LW (Light) reception. On-off switch S2 is ganged to volume control RV1; the latter is edge operated and situated at left-hand end of case as seen from the front.

**ALIGNMENT**

**Equipment required.** Signal generator with 30 per cent modulation at 400c/s and covering 200-1,200kc/s; output meter (AC voltmeter); two 0.1mF capacitors; radiating loop consisting of 20 turns of 20 SWG copper wire evenly spaced on an air-cored former 4 in. in dia. and occupying a length of 2 3/4 in. (inductance of approximately 40 micro-henries).

**Setting up.** Connect output meter across output transformer secondary and turn volume control to maximum. During alignment adjust input to limit output to 50mW. (0.4V RMS in 3 ohms).

**Procedure, IF.** Tune to a quiet spot on the MW scale near to 430m (700kc/s), then apply a 470kc/s modulated signal across L2 via two isolating capacitors (0.1mF in each lead). Adjust L10, L8 and L6 in that order for maximum output.

**Procedure, RF.** Connect the radiating loop to the generator via a low capacity screened cable and place it about 12in. from, and coaxial

with, the aerial coil L1. This latter is sealed to the ferrite rod in its optimum position and should not be disturbed unless absolutely necessary.

Set the dial to 428m. and adjust L5 and L1 for maximum output with 700kc/s signal applied to the loop. Then set to 250m. and adjust C10 and C3 for maximum output with 1,200kc/s applied. Repeat these operations as necessary, rocking tuning capacitor to avoid pulling.

Rotate dial fully anti-clockwise to operate LW switch, apply 200kc/s to loop, and adjust C11 and C2 for maximum output. Alternatively, adjust for maximum on LW Light programme transmission.

**SHEETS OR MANUAL ?**

If you are using this Chart as a separate sheet, it is probably getting torn and tattered. Why not order the Service Chart Manual in which it is reproduced?

Manuals are issued quarterly by the Publisher from 6 Catherine Street, London WC2, and contain all the charts included in ERT together with an index in the last quarter of each year. Price per volume is 4s. post free.

# Speedy Dependable Servicing

## "Tom Thumb" Miniature Tubulars

Hunt's popular "Tom Thumb" miniature Tubulars provide one of the most dependable ranges of capacitors for the modern service engineer. Small and mechanically tough, these all-aluminium dry electrolytics are available in a range of capacitances calculated to make them most useful for the majority of replacement and repair jobs. A blue insulating sleeve provides more than adequate insulation and protection to the metal tube and retains its characteristics even at high temperatures. "Tom Thumbs" are supplied in attractive display cartons each containing twelve of one list number.



"TOM THUMB"

REGISTERED TRADE MARK  
**HUNTS**  
**CAPACITORS**  
THE TRADE MARK OF RELIABILITY

TOM THUMB STANDARD RANGE						
List No.	Capacitance µF.	D.C. Wkg. Volts	Max. Surge Volts	Ripple Current m/a	Dimensions L. D.	List Price s. d.
JF405TS	16	350	400	120	1 3/8" 3/8"	4 0
JF407TS	32	350	400	200	1 3/8" 1"	6 0
JF552TS	4	450	525	40	1 3/8" 3/8"	3 0
JF553TS	8	450	525	100	1 3/8" 3/8"	3 6
JF554TS	16	450	525	150	1 3/8" 1"	5 0
JF555TS	32	450	525	225	2 3/8" 1"	7 6

If not already in your possession apply for the latest Service Trade Catalogue for full details of Dry Electrolytics, Miniature Metallised Paper, Foil and Paper, Stacked and Silvered Micacs, etc.

A. H. HUNT (Capacitors) LTD., WANDSWORTH, LONDON, S.W.18 Tel: VANDyke 6454

Factories also in Essex, Sussex, Surrey and North Wales