

THE MULLARD MASTER TEST BOARD

Type 7629

PHILIPS
"Cartomatic"
GM 7629

Operating Instructions
and Service manual

Notes and translations from 1937 to [2008](#) compiled by George Bichard

Hints and Tips

The device should be kept dust free and to be covered with a flannel cover after use.
The movable parts of the contact bridge and the keyboard have to be slightly oiled.

The keys of the keyboard have to be pushed firmly and released immediately.

It has to be checked that the soldered connections don't interfere with the free movement of the contact pins.

The cards have to be kept clean and stored alphabetically.

Never forget to check a valve with all cards belonging to it.

Unless the electrolytic capacitors have been modernised you must not store the instrument other than on its base or you risk serious internal damage caused by gradual leakage of their electrolyte (which is corrosive).

If the instrument has been moved about or not used for a long while it is advisable to leave it powered for 10-15 minutes before use to ensure that the mercury in the AX1 rectifier is properly vapourised, otherwise you risk damaging flash-overs when the HT is enabled.

General Remarks

The device works as a multimeter and as a valve tester. It allows identifying any problem in a radio and a valve.

The following problems of valves can be checked:

- a) breakage of the filament
- b) internal shorts
- c) break of electrode connections
- d) emission
- e) insulation between electrodes when the valve is heated
- f) slope (gain)

When used as a multimeter the following measurements are possible:

- a) dc voltage 0.2 - 500 V
- b) ac voltage 1 - 500 V
- c) dc current 0.1 - 1,000 mA
- d) ac current 5 - 1,000 mA
- e) resistors 1 Ohm - 5M Ohm
- f) capacitors 1 nF - 200 μ F
- g) output voltages up to about 500 V

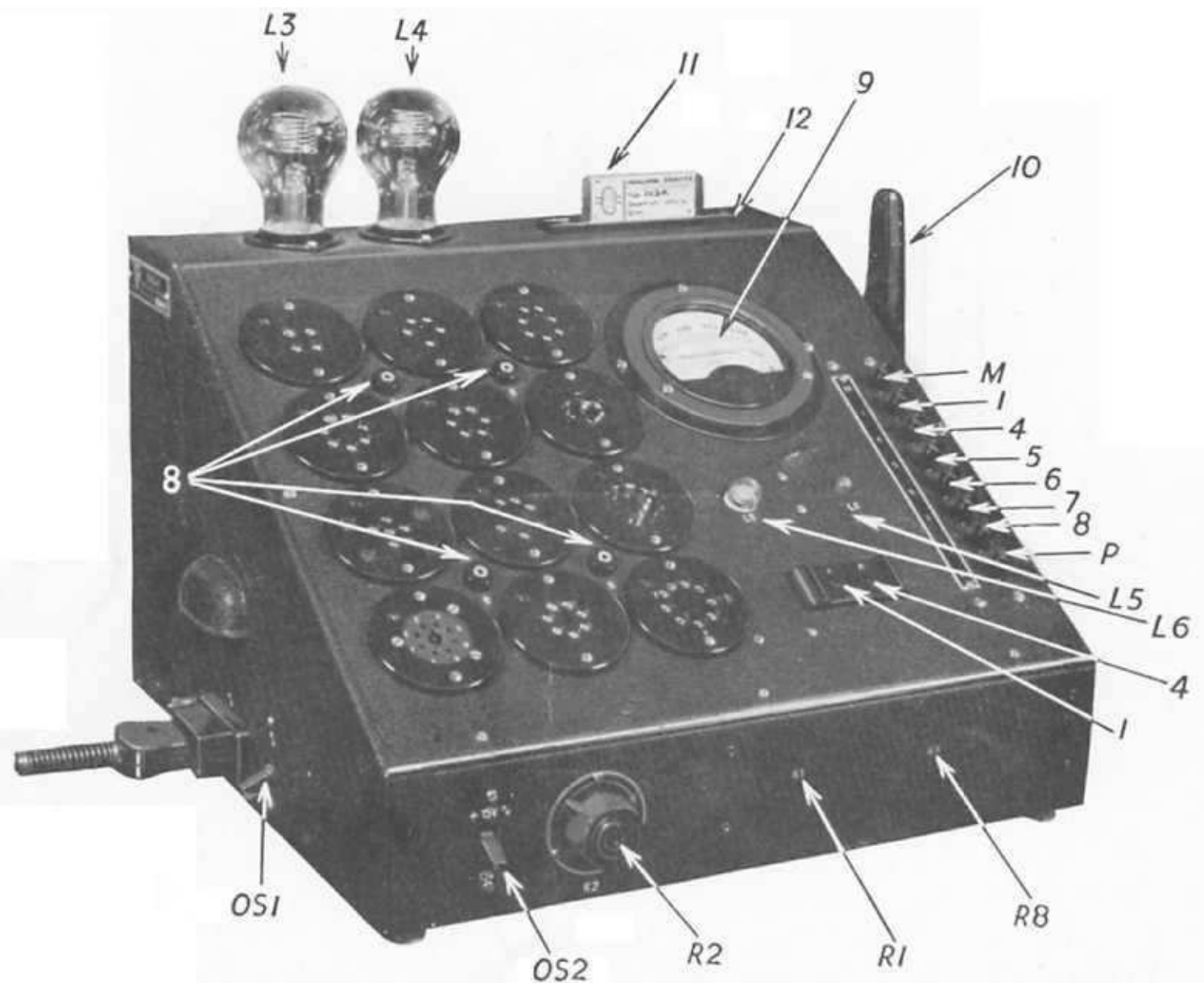

- | | | | |
|-----|--|-----|----------------|
| L3 | Neon Stabiliser (Bias voltage) | 9 | Meter |
| L4 | Neon Stabiliser (Auxiliary Voltage) | 10 | Control Handle |
| L5 | Filament Continuity Indicator | 11 | Test Card |
| L6 | Insulation Test Neon | 12 | Gate Switch |
| R1 | Primary Adjusting Screw (Bias potentiometer Voltage) | M) | |
| R2 | Main Variation Compensation Control | 1) | |
| R8 | Primary Adjusting Screw (Rejection Limit) | 4) | |
| OS1 | Mains On/Off Switch | 5) | Test Buttons |
| OS2 | Mains Variation Compensation Switch | 6) | |
| 1-4 | Test Lead Sockets | 7) | |
| 8 | Sockets for Top Cap or Side Terminal Connection | 8) | |
| | | P) | |

PRELIMINARY ADJUSTMENT

When testing receiving valves and rectifiers a preliminary adjustment of the instrument should be made by means of the four Control Cards supplied. These are numbered 1A, 1C, 2 and 3 respectively and the manner in which they are employed is described below.

CONTROL CARD 1A (*Mains Voltage Adjustment*).

Insert the card in the Gate Switch 12 (see picture). The indicator Lamp L5 will then light up and the Neon Lamp L3 will glow. Now close the Gate by means of the Control Handle 10.

Rotate the Control R2 until the meter needle points to 500 degrees. The Mains Variation Compensation Switch SW3 should be operated in conjunction with Control R2 and will provide 15 volts plus or minus adjustment to any variation in the power supply.

NOTE: Initial adjustment with the Mains Adjustment Device SW4 (see picture) can usually be made on either of the two tappings which overlap. If accurate adjustment of the instrument cannot be made on one tapping the other should be tried.

CONTROL CARD 1C (*Main Rectifier Check*).

Insert card in the Gate Switch and close the gate in the manner described. If the rectifier AX1 is working satisfactorily a minimum reading of 450 degrees will be indicated on the meter. The instrument must *not* be adjusted to regulate this reading.

CONTROL CARD 2 (*Bias Potentiometer Voltage Check*).

To adjust the voltage across the bias potentiometer, insert card in Gate Switch and close. Rotate the Primary Adjusting Screw R1 (*see Fig. 3*) either way until the meter needle registers 500 degrees.

CONTROL CARD 3 (*Rejection Limit Adjustment*).

To obtain accurate adjustment of the test limits, insert the card in the Gate Switch and close in the usual way. Rotate the Primary Adjusting Screw R8 (*see Fig. 3*) until the meter needle points to 100 degrees.

NOTE: The Control Cards 1C and 2 need only be used at the commencement of each day's work. Mains Voltage Adjustment (Card 1A) and Rejection Limit Adjustment (Card 3) should, however, be made before testing each batch of valves.

Circuit for CONTROL CARD 1A (Mains Voltage Adjustment).

When control card 1A is plugged into the gate switch contact A will be closed and the transformer is switched on (this is always the case when a card is plugged into the gate switch).

S2 delivers a voltage of 12 V which is dropped by R10 to the voltage at L5 of 6 Volts.

At the same time L2 receives filament and anode voltages. The dc voltage is stabilized by L3. The potentiometer built by resistors R1, R5, R54, R53, R52, R51, R50, R49, R48, R26, R25, R23, R22, R21, R20, R19, R18 is connected to this power source. L3 must light up when the card is inserted.

Filament voltage L2 is 4 V, anode voltage 2 x 215 V, stabilized dc voltage at L3 ~ 100 V.

When closing the gate switch the contact pins establish a connection through the corresponding holes in the card to the opposite bar. The circuit diagram corresponds to Fig 1.

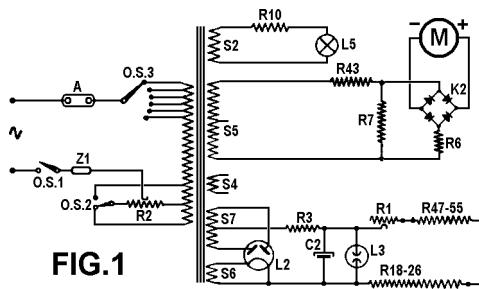

The meter is wired as a voltmeter and connected to the voltage of S5. K2 is used to rectify the ac voltage to be measured. K2, R6 and R7 are built up as a single component and fine-tuned to each other. If one of the three parts goes defective all three have to be replaced. R6 in series with the rectifier K2 takes care that the voltage at the aforementioned element at full deflection of M is exactly 5 V. Consequently M, K2, R6 and R7 form an ac voltmeter with an internal resistance of 5,000 Ohms giving 1,000 Ohms/Volt.

If the voltage across the used part of S5 is exactly 405 V the meter shows full deflection. The proper adjustment is made by potentiometer R2 that can be switched in a range of 40 Volts from -15V to +15V by OS2 for the fine adjustment of the primary voltage. The coarse tuning with OS3 adjusts the meter to the line voltages 100-125-145-200-220 and 245 Volts. If the meter shows full deflection all voltages are adjusted correctly.

Circuit for CONTROL CARD 1C (Main Rectifier Check)

The circuit formed when the control card 1C is in the closed gate switch is shown by Fig. 2.

S4 provides a filament voltage of 4 V for L1 (gas-filled rectifier valve AX1). S5 provides 2 x 250 V ac for the anodes; the dc voltage is then ~ 200 V. The maximum ac voltage that can be provided by S5 is 2x360V. C4 and C5 serve for the h.f. interference suppression. The dc voltage is kept constant independently from the current used by the filter circuit S10 and C1 and the load resistors R11/17.

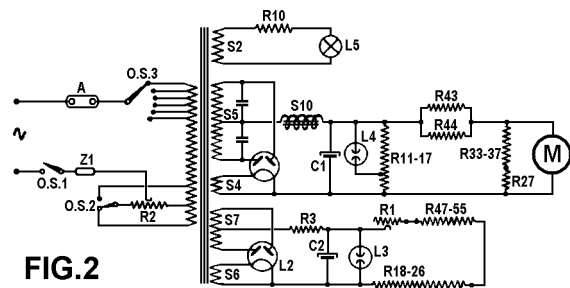

Resistors R27 and R33/37 are connected in parallel to the measuring instrument to match it to the series resistors R44 and R43. Checking of card 1C is necessary every now and then to test if the rectifier valve L1 is working properly after the line voltage has been adjusted. A deviation of up to five scale marks is allowed.

The purpose of the card is also to check if the dc voltage across C1 has the proper value. 1A, on the other hand, is used to check the ac voltages. Accordingly the descriptions 1A (alternating current) and 1C (continuous current) are chosen.

Circuit for CONTROL CARD 2 (*Bias Potentiometer Voltage Check*).

Inserting control card 2 into the closed gate switch results in Fig. 3.

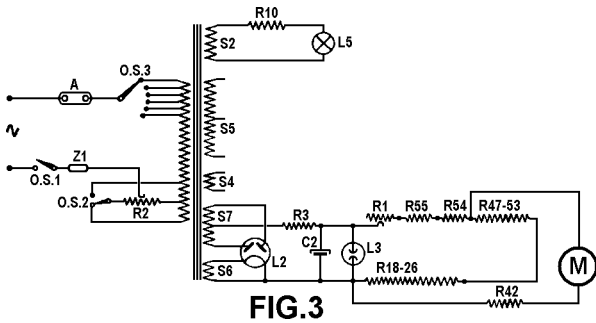

FIG.3

R42 serves as a dropping resistor for the μ A meter used as a voltmeter. The meter can be adjusted to full deflection by changing R1. The current flowing through the potentiometer R1-R47/55-R18/26 is exactly 10mA. The voltages across each resistor are therefore exactly defined. This potentiometer is later used to obtain the negative grid voltage for the valve to be checked.

If the resistor R1 is not properly adjusted the measurements at the valve lead to false results due the incorrect grid voltage.

Circuit for CONTROL CARD 3 (*Rejection Limit Adjustment*)

Inserting control card 3 into the closed gate switch results in Fig. 4.

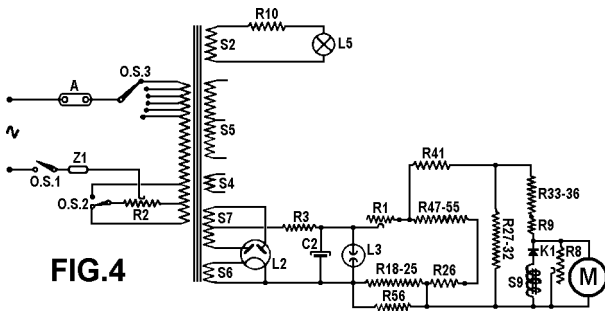

FIG.4

The current through the measuring instrument is adjusted by R8 so that it, together with K1-S9 and R8 parallel to the instrument, is exactly 0.1mA. The first 100° are marked red. When used for measuring the emission of a valve this range shows the limit of the usefulness of valve checked. K1-S9 are for the following reasons connected in parallel to the measuring instrument....

If while a valve is checked a short-circuit between cathode and grid occurs the anode current could rise to such a height that the measuring instrument could be damaged. The internal resistance of the rectifier cell K1 is getting smaller with rising voltage on the measuring instrument. It therefore protects the instrument. The internal cell resistance is in the range of 700 to 1,000 Ohms at normal deflection. If the voltage at the measuring instrument rises to a high value the resistance drops to a few Ohms and the current that would flow through the instrument is shunted by the rectifier. The instrument is thus protected.

If a rectifier valve is checked a complication occurs. The current flowing through the anode is in this case is a pulsating dc current. During its peak the current would flow through the Cuprox rectifier. It is therefore necessary to connect the coil S9 in series with the Cuprox rectifier to obtain a proper reading from the instrument.

Circuit for CONTINUITY/INSULATION TESTER (200V)

By inserting an arbitrary card into the opened gate and by pressing one of the buttons 1 or 4 the circuit is configured as shown in Fig 5. If now a short circuit is connected between 1 and 4 the lamp L6 will light up. Note that for a lower voltage test you can use the Measurement Card covering the range of 0-200 ohms.

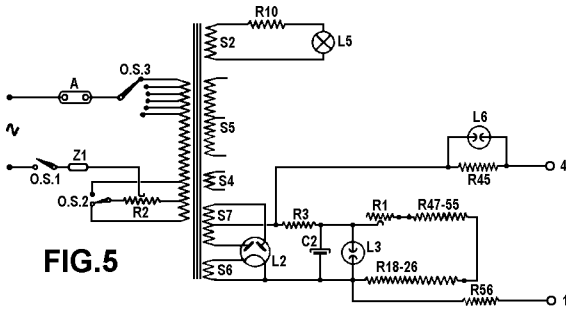

Circuit for OUTPUT POWER METER

In this application S10 and C3 are used to protect the meter from possibly existing dc voltages at the output pins of the device to be checked. The simplified circuit diagram is Fig 6

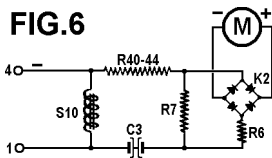

The deflection of the meter is non-linear due to the frequency dependency of K2. The cards for measuring the output power don't have a transformation scale because only the maximum of the deflection is used when adjusting a device.

VALVE TESTING

After the four preliminary adjustments have been made the instrument is accurately set for testing valves. The procedure to be adopted for each of the various valve tests which can be made with the board is detailed below. The tests are described in the correct sequence and this should be followed for the systematic testing and the avoidance of unnecessary operations.

With the exception of Test 6 (Slope), Rectifiers and Double-Diodes are tested in the same way as ordinary receiving valves.

A. TESTS WITH HANDLE DOWN (*Gate Switch Open*)

1. FILAMENT OR HEATER CONTINUITY

Select the Test Card which corresponds to the valve about to be tested. Take particular care that the card corresponds not only in type number but also in base type. There are, for example, separate cards for valves available in 5 or 7 pin bases.

Insert the selected card in the Gate Switch but *DO NOT CLOSE THE SWITCH*. Now plug the valve into the appropriate socket on the board, attaching the connector lead to the top cap or side terminal if any and plugging the lead into the nearest socket 8.

If the filament or heater is intact the indicator L5 will either be extinguished or considerably dimmed. If its brilliancy remains unaffected, the filament or heater circuit of the valve is broken. (The valve may be tapped to ensure that there is no intermittent fracture).

By inserting the card that belongs to the valve to be checked into the slot the transformer is switched on. L5 and R10 are connected in series with the 12 V of S2. As already mentioned the voltage drop on R10 is sufficiently high that L5 receives the proper voltage (6 V). When the gate is open a connection is made between pin "e" and the pins on the rear side of the gate, 2 and 3. The pins 2 and 3 of the socket are now connected in parallel to L5. If now the valve is inserted into its socket the current rises and the voltage drops and thus L5 is partly dimmed or totally off. If the filament is broken L5 will be normally lit. The complete extinction of L5 depends on the resistance of the filament of the checked valve.

2. SHORT CIRCUITS

If Test 1 reveals no defect, the valve--while still cold--should now be examined for short circuits. *THE GATE SWITCH MUST REMAIN OPEN.*

The Electrode Insulation Test Buttons are employed in this test. Each of these buttons is numbered to correspond to the numbers which appear against each electrode in the theoretical diagram printed at the top of all Test Cards. It is therefore only necessary to press the buttons which apply to the electrodes of the valve under test. Thus, in the case of an indirectly heated triode fitted with a 5 pin base only the following buttons need be used.

No.1	Anode.
No.4	Control Grid.
No.5	Cathode.

The appropriate buttons should, therefore, be pressed in numerical sequence. The electrodes between which a short circuit exists are indicated by the neon L6 glowing when certain buttons are pressed. For example, if the indirectly heated triode described above is under test and the neon glows when buttons 1 and 4 are pressed, this indicates that a short circuit exists between Anode and Control Grid.

By pressing one of the buttons 1 to P the pin of the valve socket with the same number will be connected via C - bar a - b - R45 and the Neon lamp to dc voltage provided by L2 (200 Volts at R3).

If a short circuit e.g. between electrodes 5 and 6 exists in the checked valve the following circuit is established by pushing button 5:
filament L2 - R56 - d6 - socket pin 6 - electrode 6 - electrode 5 - c5 - bar a - b - R45 - S7 - anode L2 - filament L2.

A voltage builds up across R45 that is inversely proportional to the short circuit resistance of the checked valve. L6 will light up more or less. The lighting up of L6 (when button 5 is pushed) shows that the electrode 5 has a short circuit with one or more other electrodes. To find out which electrodes are involved the other buttons of the switch have to be pressed, the connection between c5 and a-b has to be interrupted and the connection between c6 and a - b to be established. A new similar circuit will be established, now via c6. If there are more short circuits between electrode 5 and other electrodes L6 will light up again when the appropriate button is pressed.

3. CHECKING THE CONNECTION BETWEEN METALLISING AND THE ASSOCIATED PIN.

An external connection should be made between the metallising and any contact selected at random of another valve socket (excepting one bearing the same number as the metallising connection). The neon indicator L6 should glow when the button corresponding to the metallising is pressed, the if connection is good.

NOTE :

In the case of an indirectly heated valve which has been pre-heated (i.e. where the cathode is hot), the neon L6 will glow when the button relative to the cathode is pressed. This, however, does *NOT* indicate a fault.

B. TESTS WITH HANDLE UP (*Gate Switch Closed*)

4. TEST FOR ANODE CURRENT

Valves which have passed tests 1 and 2 should now be submitted to this fourth test.

In the case of indirectly heated valves first press the Insulation Test Button which corresponds to the cathode. Then close the gate to apply the necessary voltages and allow sufficient time for the cathode to heat up when the neon L6 should glow. Directly the glow is observed, press and release button M to obtain an emission reading.

If L6 does not glow after time has elapsed sufficient to heat the cathode a low vacuum or disconnected cathode is indicated.

In the case of directly heated valves this test may be applied by pressing button P. (instead of the cathode button). The neon L6 should glow almost immediately. Button M is then pressed as for indirectly heated valves to obtain a meter reading.

For the purposes of emission readings the meter scale is divided into the following coloured sections:

From Zero to 100°	Red.
From 100° to 150°	Blue & White.
From 150° to 500°	Blue.

If the meter needle remains in the red section the valve is, in our opinion, bad and should be renewed. If it reaches the blue section the valve is satisfactory as far as the anode current is concerned.

At this stage one should point out that it is impossible, when dealing with many varieties of valves, to adopt a hard and fast rule regarding the point at which renewal should be advised. Although regular valve replacement is desirable a certain amount of discretion must be used and the blue and white section on the scale is merely intended to provide a guide to the recommendation of new valves where the condition of those under test is doubtful.

5. TEST FOR INSULATION AND ELECTRODE DISCONNECTIONS WITH VALVE AT WORKING TEMPERATURE.

The Electrode Insulation Test Buttons are again employed in the fifth test in the sequence is necessary. Press the appropriate buttons (*see* Test 2) bearing in mind that the neon L6 will glow in any case when the cathode button is used, or button P in the case of directly heated valves.

Faulty Insulation and short circuits will be indicated on the neon in precisely the same way as for Test 2. At the same time, however, the anode current reading will drop to zero if the electrode relative to the button pressed is satisfactorily connected. This does not apply in the case of the Metallising and Cathode buttons.

When applying this test to the anode of pentode valves, it is important that the associated button be depressed no longer than is necessary to ascertain that a fault does not exist, as otherwise the auxiliary grid may become overheated, and give indications of faulty insulation due to the emission from the heated electrode.

By closing the gate the socket pins of anode, screen grid, grid, and cathode will be connected to the horizontally drawn connections A-Gs-G and K because the contact pins connected to these connections touch one of the bars 1-4-5-6-7-8 through the holes in the card. If e. g. 8 is the anode, 6 the grid, 5 the screen grid, and 4 the cathode, the following holes are punched into the card:

opposite of bar 8 a hole at the position of the first contact pin,
" " " 6 " " " " " " " " third " " ,
" " " 5 " " " " " " " " second " " ,
" " " 4 " " " " " " " " fourth " " .

Due to this fact only one valve socket of each type is necessary, even if the pins at different valves are connected to different electrodes.

The valve gets its filament voltage by holes in the card close to the left bars. Thereby it is possible to check valves with filament voltages from 0.5 to 56.5 Volts.

The plate voltage is provided by L1 and can be adjusted between 70 and 300 Volts. This is accomplished by punching holes into the third and fourth bar (from the left side). Contact pins connected to the taps of S5 access the bars which can for their part be connected to the anodes of L1. This is done by punching both lower holes into the card at the level of the bars. If bar 6 is accessed by a hole in the card a smaller or larger part of R11/17 + R57 + R59 is used as load resistor. A voltage can be tapped from this resistor by punching a hole to bars 5 and 6.

The screen grid voltage can be taken from this resistor as well. It is adjustable from 60 to 300 Volts. If the screen grid voltage is lower than the plate voltage when it is derived from the potentiometer it will be stabilized by L4.

If the valve to be checked is a rectifier valve the plate voltage can be taken from bars 3 or 4 too. A smaller or larger part of the resistor combination mentioned above is used as load resistor.

The maximum current from the plate voltage circuit is 100 mA. The load resistors can be adjusted from 250 to 9000 Ohms. The ac voltages for the rectifier valves can be adjusted from 1 x 22 to 2 x 360 Volts.

The valve gets its negative grid voltage from bars 7 and 8; it is adjustable from 0 to 74 Volts.

Emission check

The valve gets the proper voltages if the gate is closed. If the button is pushed that has the same number as the cathode on the card the cathode will be disconnected from the common zero point of plate and screen grid voltage and connected to -200 Volts via R45 - L6. The voltages of all grids and the plate are consequently increased by 200 Volts. A grid current could be triggered. Due to the high value of R45 it will be limited to some μ A and can be tolerated by the valve. The current generates a voltage across R45 and L6 will light up.

If the plate connection is broken and the pointer of the meter doesn't move it can be checked if the valve still has emission or not.

If valves are heated directly the cathode will be replaced by the electrical centre of the filament formed by R4 - R5. This point is connected to the tappet P. The check of the valve has to be performed by pushing button P.

Check of the insulation of the hot valve

If another button is pushed the tappet c that is connected with the cathode or with the electrical centre of the filament is released from the bar with -200 Volts and will be connected to the zero point of the voltage. The other electrode is furthermore connected to -200 V. The measurement is the same as the short circuit measurement but the valve is operating at the normal operating point. If a short cut exists the

6. SLOPE

The final test in the sequence provides a check on the slope of the valve. By depressing the button M an additional negative voltage will be applied to the grid of the valve thereby causing a drop in anode current.

This test is purely comparative, the variation in anode current depending upon the type of valve under test.

COMPARISON OF VALVE CHARACTERISTICS.

Comparison of the anode current of valves may be undertaken at two points on the anode current/grid volts characteristic curve i.e., under normal test conditions and with an extra two volts negative grid bias applied (by holding down the button M.).

It must be appreciated that in order accurately to *match* the characteristics of two valves it is necessary to make measurements under conditions obviously out of the scope of this instrument.

NEON STABILISERS.

It should be noted that the Neon Stabiliser L3 (Fig. 3) controls the grid voltage while the Neon Stabiliser L4 controls an auxiliary voltage. The latter neon only glows under certain conditions and a fault is not necessarily indicated if it is not glowing.

Limit of Usefulness

If the button M is pushed and released again, the bar -200 Volts is pressed back. The tappet that has been connected to the bar will be disconnected. The button M does not have a tappet and returns back in the position "Off"

To determine the limit of usefulness independently of the current through the valve the resistors R27 to R39 are used as shunt or dropping resistor. About 70 different shunt values can be configured.

Gain

If the button M is pushed permanently the short circuit of R46 is removed and this resistor is connected to the potentiometer R18/26 - R47/55 - R1. The negative grid voltage of the valve to be checked is increased by 2 V and the plate current is reduced by a certain amount. This reduction is a measure of the gain.

Check of the internal connections in the valve

If the buttons 1 to P are pushed one after the other the negative voltage of 200 Volts is applied to the different electrodes of the valve; the plate current drops to zero or almost zero. If one of the connections is broken, the voltage is not applied to it and the meter does not react to the negative voltage.

If a dual diode or a double phase rectifier valve is checked and the button that does not belong to that plate is pressed the plate is connected to -200 V with respect to the cathode or the filament. This plate doesn't let current pass and the current at the other plate rises. This effect is the opposite of that at a triode. The same happens with a multi plate valve if the respective button is pressed. A negative voltage is applied to the respective plate. The buttons have to be pushed quickly one after the other so that the screen plate current does not rise too much.

L3 and L4 are neon lamps 4357. L4 has to be selected so that the burning voltage at 30 mA is between 93 and 97 Volts. The lamp is named L4. If L4 is defective a new one has to be selected with the help of card 4. Card 4 has to be inserted into the closed gate switch. The appropriate lamp has to cause a full deflection of the meter (tolerance 2 %).

Via resistor R1 the current through the potentiometer and thus the negative plate voltage can be adjusted. Each lamp 4357 can therefore be used for L3.

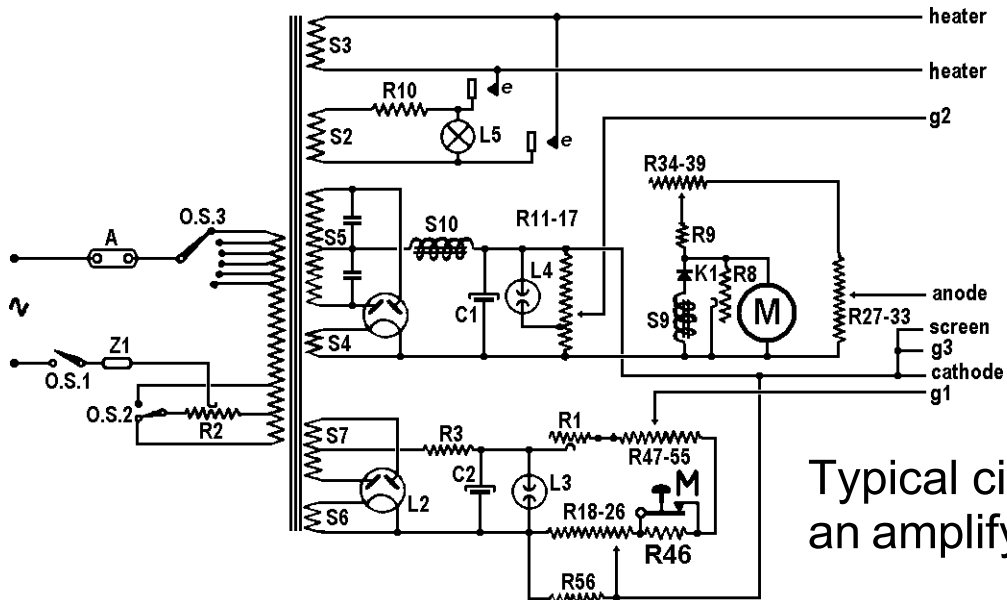

Typical circuit for testing an amplifying valve.

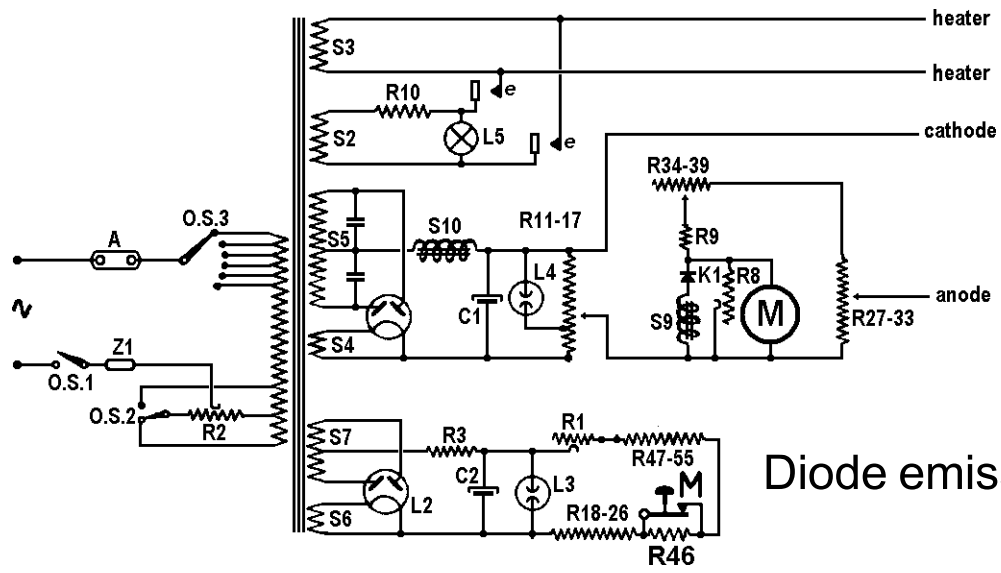

Diode emission test

Rectifier operational test

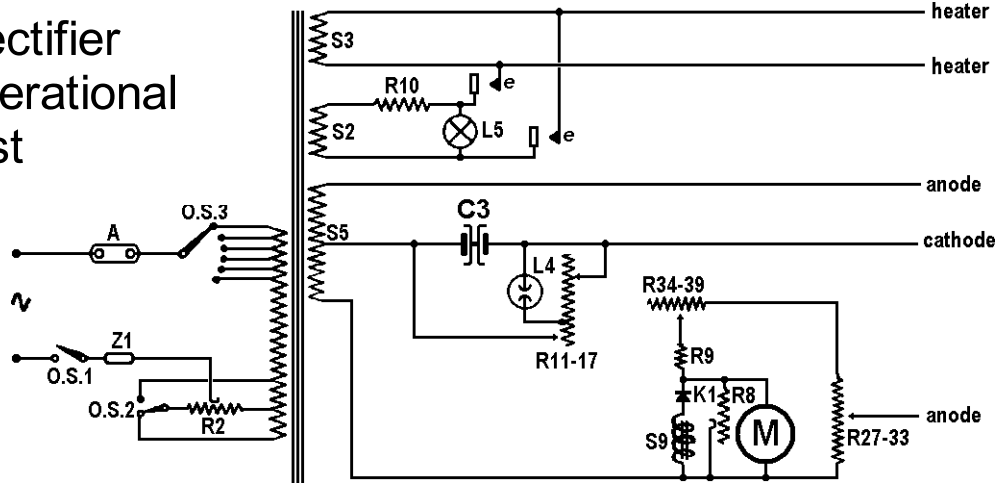

RECEIVER ANALYSIS.

Special cards are provided for Capacity and Resistance measurements. At the top of each card is a conversion scale, the bottom reading of which (0 to 500°) represents the meter scale while the top reading represents the measurement to be taken.

CAPACITY AND RESISTANCE MEASUREMENTS.

Select the appropriate Measurement Card, insert in Gate Switch and close. Switch on the instrument at the On/Off Switch SW1 and plug test leads into the Sockets 1 and 4 taking care that the plug pin indicated by a red spot (positive) is in the socket similarly marked. These leads terminate in two 4mm plugs which may be adapted to all requirements with the aid of the crocodile clips and special plunger test prods which are provided.

On the following ranges measurements are made IN PARALLEL with the meter.

Capacity	10-200 mfd.
Resistance	0-200 ohms, 20-4,000 ohms and 1,000-50,000 ohms.

The meter will therefore register a reading immediately the Gate Switch is closed. Adjust this reading to exactly 500 degrees on the meter scale by means of the Controls SW3 and R2 (Fig. 3).

On all other ranges of Capacity and Resistance, measurements are made IN SERIES with the meter. After the Gate Switch has been closed, but before any measurement is made, short circuit the test leads, and by means of the Controls SW3 and R3, adjust the meter reading for full scale deflection.

After either of these preliminary adjustments has been made, apply the leads to the component under test. The meter needle will now indicate a reading and by reference to the conversion scale this can be converted into ohms or microfarads.

NOTE : When using the 0-200 ohms card it will be found that the meter needle will not fall right back to zero with the test leads shorted. The residual reading represents the internal resistance of the instrument and should be allowed for if accurate readings are required at very low values.

ELECTROLYTIC CONDENSERS.

Always use the highest range card possible when testing electrolytic condensers. 14 mfd condensers, for example, should be tested on the 10-200 mfd card.

VOLTAGE AND CURRENT MEASUREMENTS.

It is *not* necessary to switch on the instrument at the On/Off Switch SW1 (Fig 1) for voltage and current measurements. After selecting the appropriate card, inserting in the Gate Switch and closing, measurements can be made by means of the test leads.

The resistors R40 - 44 are used as dropping resistors, R27 - 39 are shunt or dropping resistors when voltages, currents, resistors or capacitors are measured. When measuring resistors the dc voltage C1 is used; capacitors are measured using the 50 Hz ac voltage.

When the last-mentioned measurements are made, the meter has to be adjusted to full deflection using the primary voltage, R2.

OUTPUT MEASUREMENT.

For this test proceed as for Voltage and Current measurements. It is again not necessary for the instrument to be switched on.

Insert the terminal plugs of the test leads into the extra speaker socket of the receiver or connect across the output. An output reading for sensitivity tests or ganging is then obtained.

NOTE : As these measurements are intended for the alignment of radio receiver circuits which require only a relative indication of the output voltage, conversion scales are not provided.

The Measurement Cards provided for the ranges of 0-100 and 0-500 volts should be used where the extra speaker terminals of the receiver are connected across the primary of the output transformer.

The Measurement Card provided for the range of 0-25 volts is used when these terminals are connected across the secondary of the output transformer.

In this application S10 and C3 are used to protect the meter from possibly existing dc voltages at the output pins of the device to be checked. The simplified circuit diagram is Fig 6

The deflection of the meter is non-linear due to the frequency dependency of K2. The cards for measuring the output power don't have a transformation scale because only the maximum of the deflection is used when adjusting a device.

CIRCUIT CHECKS.

The Measurement Card covering the range of 0-200 ohms can be usefully employed for checking wiring continuity, soldered joints, etc.

After inserting card in the Gate in the usual way, apply the test leads with the aid of the crocodile clips or prods as necessary, to any points in the wiring. As the instrument will register resistances below 1 ohm, dry joints can be easily located.

The same procedure may be adopted for checking the resistance of switch contacts etc.

For a neon continuity test, press button 1 after inserting card in gate and use test leads in normal manner. The control handle can be either up for down.