

4. SW2~SW19 Tuning Capacitor Driving Cord

String the cord by removing the SW2-SW19 front end block from the chassis.

Dial Film Setting

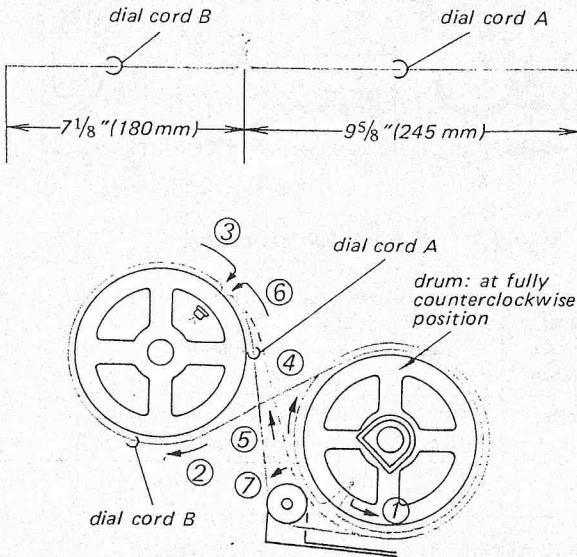

Fig. 2-27

5. SW2~SW19 Calibrator Dial Cord

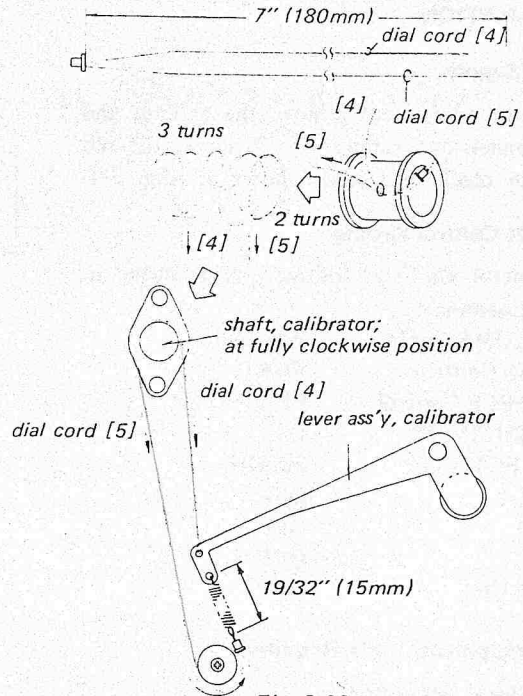

Fig. 2-28

6. Dial Film Setting

1. Set the top of dial film to the film-drum as shown in Fig. 2-29 (step ①).
2. Attach the other end of dial film with an adhesive tape (step ②).
3. Turn the ratchet-wheel four turns in the direction shown by the arrow (step ③).
4. Set the side mark of the film on the film setting position. After setting the film you must keep the film with fingers or adhesive tape so that the film does not move.
5. String the dial cord as shown in Fig. 2-29 (step ⑤).

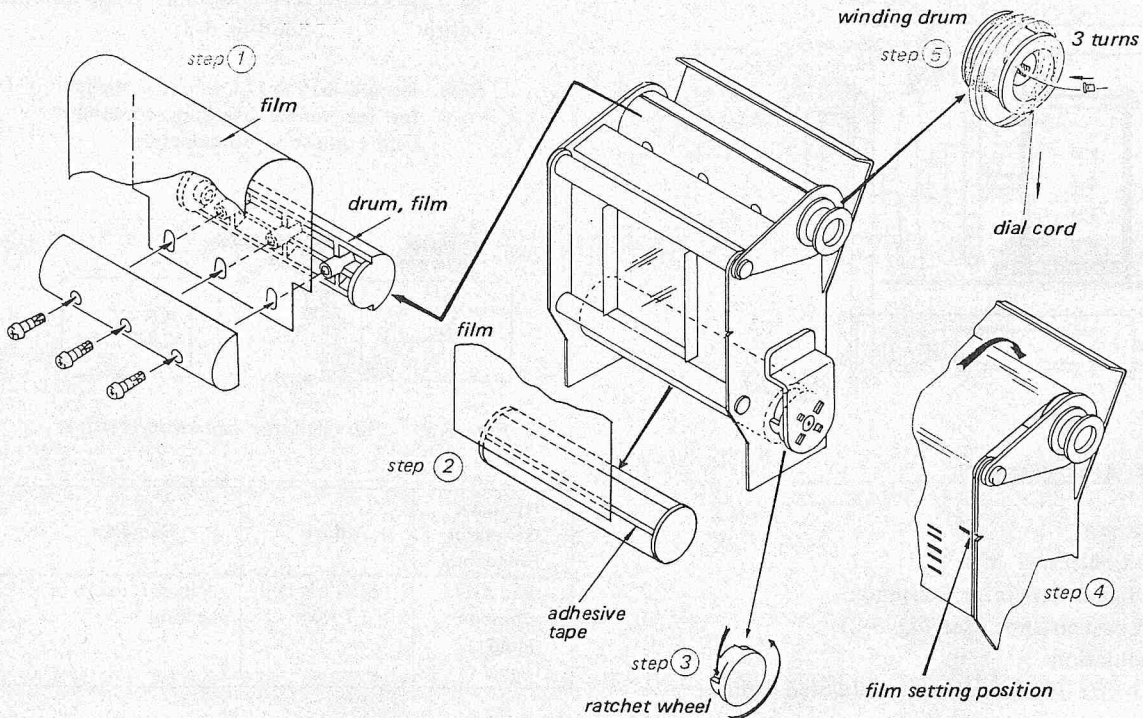

Fig. 2-29