

Fig. 5. Schematic Diagram, Models 514, 542 and 543

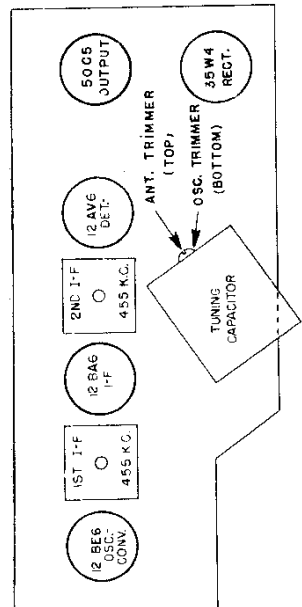

Fig. 6. Location of Tubes and Adjustments

©John F. Rider

**MODELS 514,  
542, 543**

**SPECIFICATIONS**

OVER-ALL CABINET DIMENSIONS	MODEL	514	542	543
	Color	Mahogany Mottle	Brown Mottle	Ivory
	Height	6¼ in.	6¾ in.	6¾ in.
	Width	10½ in.	11¾ in.	11¾ in.
	* Depth	6¼ in.	6¼ in.	6¼ in.

\* Including knobs

ELECTRICAL RATING	Voltage	105-120
	Frequency	60 cycles only
OPERATING FREQUENCIES	Standard Broadcast	540-1600 kc
	I-F Amplifier	455 kc
POWER OUTPUT	Undistorted	1 watt
	Maximum	1.75 watts
LOUDSPEAKER	Type	Alnico PM
	Outside Cone Diameter	4 inches
TUBE COMPLEMENT	Purpose	Type
	V1 Oscillator-Converter	12BE6
	V2 I-F Amplifier	12BA6
	V3 Detector—1st Audio	12AV6
	V4 Audio Output	50C5
V5 Rectifier	35W4	

**PRODUCTION CHANGES**—Two versions of the Models 514, 542 and 543 are noted in the tube socket construction, involving production methods.

**MECHANIZED CHASSIS**—Mechanized production uses sockets of the dip solder construction. In this operation components and wires are placed into tube pin connections of each socket. The chassis is inverted and dipped into molten metal, to solder the pins from the top. A plastic cover over the top of the sockets insulates these connections against shock hazard.

**NONMECHANIZED CHASSIS**—A part of production employed the standard method of the past, in socket wiring. In these chassis, components are wired, crimped and individually soldered to standard socket pin connections. Nonmechanized chassis have the letter "C" rubber stamped on the rear chassis apron for identification.

**COMPONENT REPLACEMENT**—When servicing mechanized chassis, the time and effort otherwise spent to remove the shield, heat tube pin connections and free the components may be spared. A neater job can be done without the risk of damage to the tube sockets by using the following method in wiring a replacement part.

Clip the defective unit out, leaving enough of its leads attached to the tube socket so an eye loop may be formed in the leads. Each lead of the new component may then be passed through the proper loop, pruned to length, crimped and soldered.

**CAUTION:** One side of the power line is connected to B-. Avoid any ground connections direct to B-. Use an isolating transformer when making service adjustments with the chassis removed from the cabinet.

**GENERAL INFORMATION**

The Model 514, 542 and 543 clock-radio receivers employ four tubes, plus rectifier tube, in a superheterodyne circuit. A loop antenna, part of the cabinet back, provides excellent signal pick-up, without the need of an external antenna. Each model has an electric alarm clock which is also connected to automatically turn on the radio as a Musical Alarm. The clocks of receiver Models 542 and 543 have the additional Sleep Control feature to permit one hour of radio operation, or a portion thereof, where upon the control mechanism will automatically shut off the radio.

**CIRCUIT ALIGNMENT**

Always have volume control at maximum and use the minimum amount of signal input necessary to produce a suitable output response.

**ALIGNMENT CHART**

Step	Connect Test Oscillator to	Test Osc. Setting	Dial Drum Setting	Adjust for Maximum Output
1	12BA6 grid (1) in series with 0.05 mf. cap.	455 kc	Minimum capacity	Cores of 2nd I-f transformer T3
2	12BE6 grid (7) in series with 0.05 mf. cap			Cores of 1st I-F transformer, T2
3	Inductively coupled to Radio loop	1620 kc		C1D (oscillator)
4		1500 kc	Tune for max.	C1A (antenna)

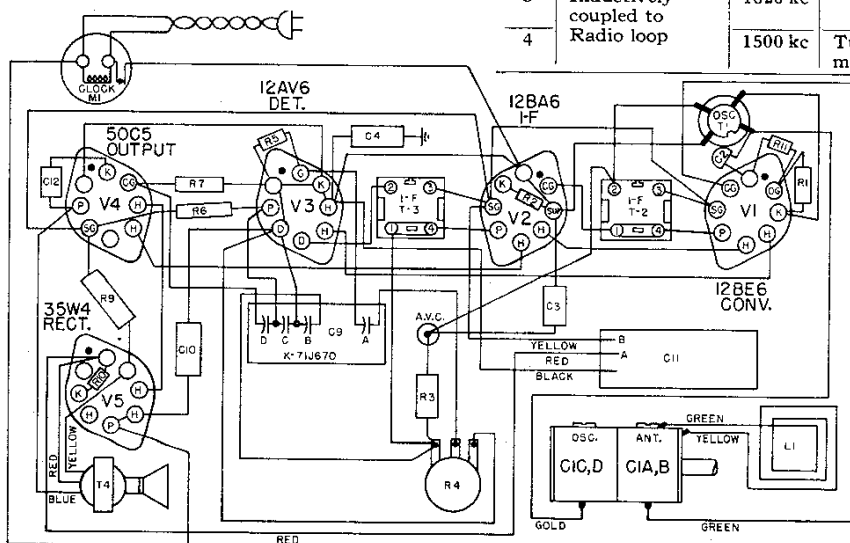

Fig. 7. Wiring Diagram

**CLOCK SERVICE**

Figures 8, 9 and 10 show clock parts referred to in the following paragraphs and the parts list.

**CLOCK MOVEMENT DISASSEMBLY**

1. Remove clock movement from case, and pull off knobs.
2. Remove Crystal, Hands and Dial Face.
3. Remove the motor assembly by removing two screws (13) and break two soldered joints on Field. The Field and Rotor Assembly (22 and 23) can now be removed. The Rotor is held by friction only, to the Field.
4. Remove Switch Assembly (4) by removing two screws from base plate.
5. Remove Switch Shaft Assembly (8) and spacer.
6. Remove Alarm-Set Shaft Assembly (31) and spacer.
7. Remove the three front plate assembly screws that are located under the Dial Face and then remove Front Plate.
8. Remove Alarm Gear Sleeve Assembly (17), Hour Gear Sleeve Assembly (18), Minute Gear Sleeve Assembly (19), and Sweep Second Gear Shaft Assembly (20).
9. Remove Alarm Cam Gear Assembly (26) and Spring Washer (25).
10. Remove Intermediate Gear (27).
11. Remove Time-Set Gear and Shaft Assembly (11).
12. Remove Switch Cam Lever (12).

**CLOCK MOVEMENT REASSEMBLY**

Reassemble in the reverse order of disassembly, observing the following precautions:

1. The spring washer (25) should curve away from the gear when placed on the Alarm Cam Gear Assembly (26).
2. The Switch Cam Lever (12) fork must straddle the base plate post as shown in the illustration.
3. After reassembly of front plate, check, the Sweep Second Gear (20) through the hole in the base plate to make sure it is free to turn.

4. Proceed with Alarm and Switch Adjustments as described below before installing hands.

**ALARM AND SWITCH ADJUSTMENTS**

1. Turn Switch Knob to Wake-up position.
2. Slowly rotate Time-Set Shaft clockwise until the contacts of the Switch Assembly (4) close.
3. Replace Dial Face, Alarm Dial, the Minute, Hour and Second Hands. Set all Hands and Dial so that they indicate 12 o'clock. Make sure all Hands and Alarm Dial are tight on their respective shafts.
4. With Alarm-Set knob pulled out, continue to rotate Time-Set Shaft clockwise and note that the vibrator arm drops against field core approximately 7-10 minutes later.
5. Set alarm at some other selected position and make sure mechanism actuates within limits ( $\pm 1$  minute).
6. Check alarm tone of vibrator. This can be adjusted by either bending vibrator arm nearer or farther away from field core. Bend arm near anchor point.

**CLEANING AND LUBRICATION**

To clean, completely disassemble and clean all moving parts in carbon tetrachloride or some similar cleaner.

The inside of the sleeves and shaft surfaces may be cleaned of oxidized oil by rubbing with a fine grade of steel wool dampened in carbon tetrachloride.

Do not use too much oil and apply by means of a small wire (drop oiler). Too much oil collects dust and later oxidizes. Use only recommended clock oil, such as Nye's Celebrated Oil, which may be purchased from Wm. F. Nye Co., Inc., New Bedford, or an equivalent.

**CLOCK TROUBLES**

1. Clock will not operate—Defective field coil, defective rotor, binding of parts.
2. Clock loses time—Binding parts, too little friction on minute hand sleeve assembly, defective rotor. Clock time-set shaft bent and rubs against hole in clock bracket.
3. Noisy Clock—Rotor defective, alarm armature improperly adjusted, loose parts, or binding of moving parts.

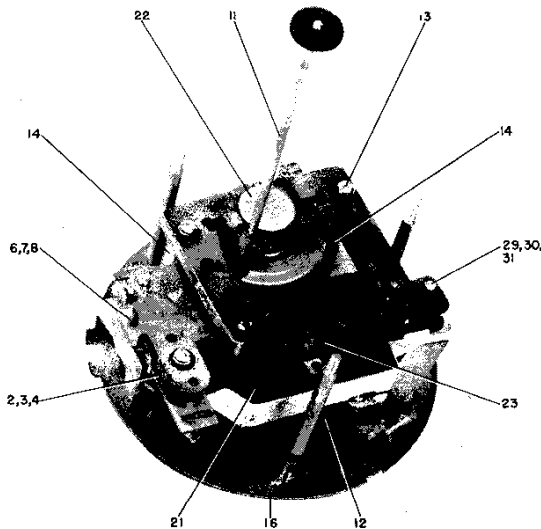

Fig. 8. Back View of C51 Clocks

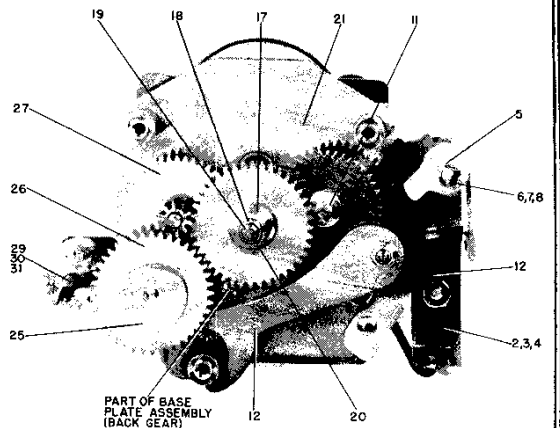

Fig. 9. Front View of C51 Clocks—Front Plate Removed

MODELS 514,  
542, 543

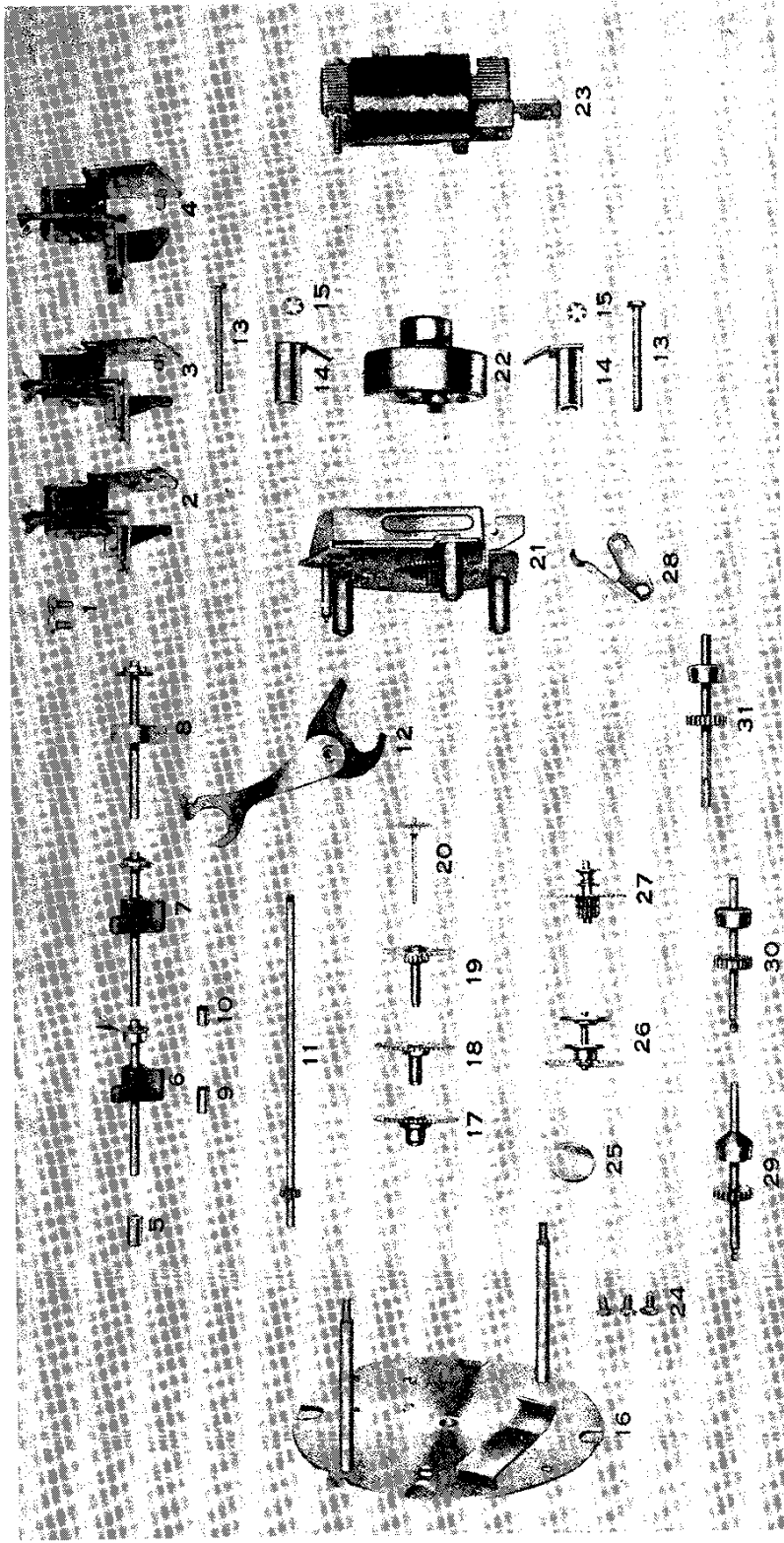

Fig. 10. Exploded View of C51 Clock Movement

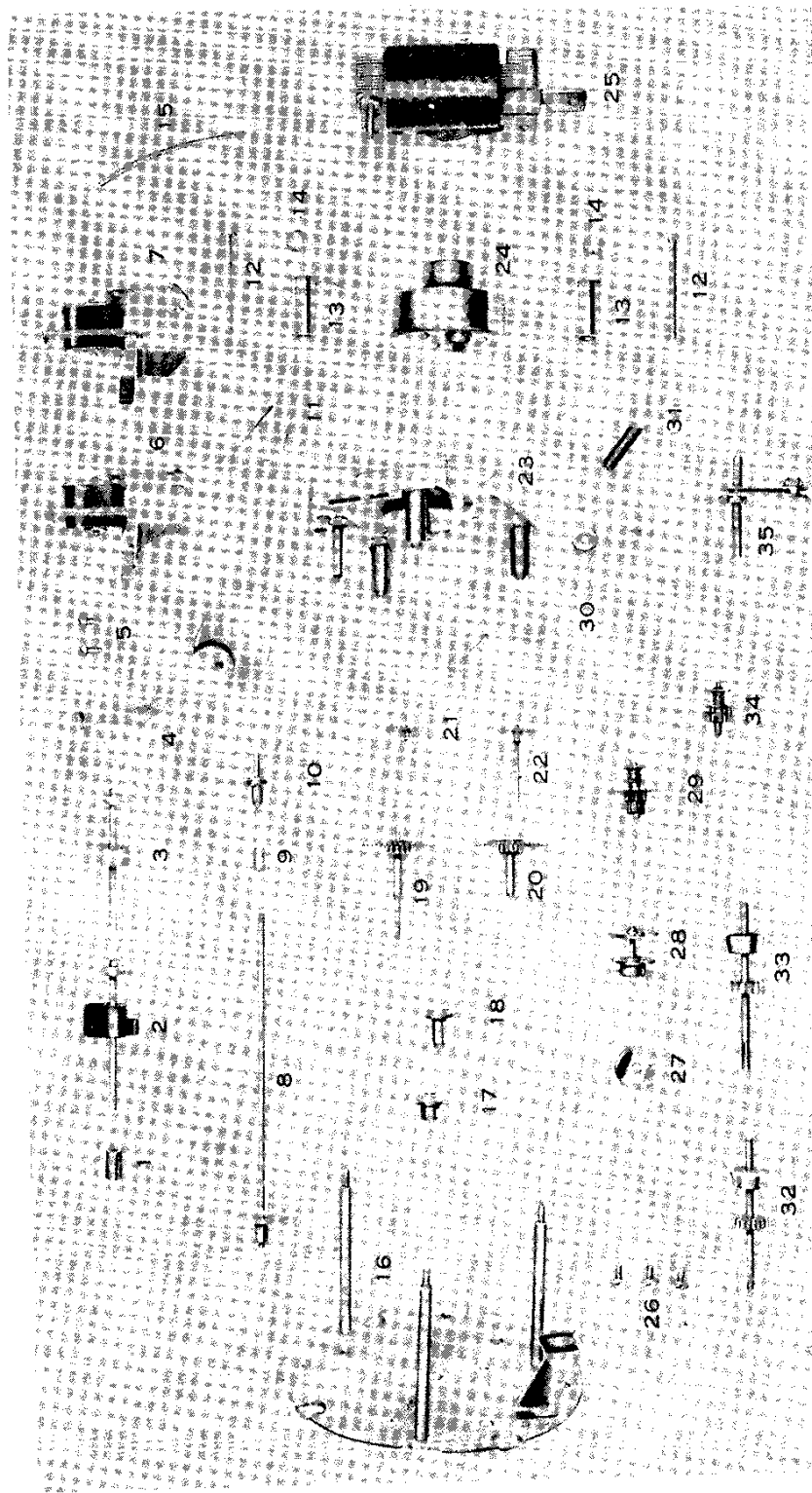

Fig. 13. Exploded View of C57 Series Clock Movement

© John F. Rider

MODELS 514,  
542, 543

CLOCK SERVICE

Figures 11, 12 and 13 show clock parts referred to in the following paragraphs and the parts list.

CLOCK MOVEMENT DISASSEMBLY

1. Remove clock movement from case, and pull off knobs.
2. Remove Bezel, Hands and Dial Face.
3. Remove the motor assembly by removing two screws (12) and break two soldered joints on Field. The Field and Rotor Assembly (25 and 24) can now be removed. The Rotor is held by friction only, to the Field.
4. Remove Switch Assembly by removing two screws (5) from base plate.
5. Remove Switch Shaft Assembly (3) and spacer.
6. Remove Alarm-Set Shaft Assembly (33) and spacer.
7. Remove the three front plate assembly screws that are located under the Dial Face and then remove Front Plate.
8. Remove the following gear assemblies and control levers in the order listed below:
  - (a) Sleep Control Shaft and Segment Gear (35)
  - (b) Alarm Dial Gear (17)
  - (c) Hour Hand Gear (18)
  - (d) Alarm Signal Cam and Gear, and Friction Washer (28, 27)
  - (e) Sleep Control Switch Lever (30)
  - (f) Pinion Drive Gear Assembly (34) (drives Sleep Control Segment Gear)
  - (g) Alarm Control Switch Cam Lever (4)
  - (h) Time Set Shaft and Gear, and Spacer (8, 9)
  - (i) Drive Gear and Pinion Assembly (29)
  - (j) Minute Hand Gear (20)
  - (k) Sweep Second Hand Gear (22)

CLOCK MOVEMENT REASSEMBLY

Reassemble in the reverse order of disassembly, observing the following precautions:

1. The spring washer (27) should curve away from the gear when placed on the Alarm Cam Gear Assembly (28).
2. The Switch Cam Lever fork (4) must straddle the base plate post as shown in the illustration.
3. After reassembly of front plate, check the Sweep Second Gear (22) through the hole in the base plate to make sure it is free to turn.

4. Proceed with Alarm and Switch Adjustments as described below before installing hands.

ALARM AND SWITCH ADJUSTMENTS

1. Turn Wake-Up Manual shaft to WAKE UP position.
2. Slowly rotate Time Set Shaft clockwise until the contacts of the Switch Assembly (7) close.
3. Replace Dial Face, Alarm Dial, the Minute, Hour and Second Hands. Set all Hands so that they indicate 12 o'clock. Set figure 12 of the alarm dial to index with the smaller pointer of the hour hand. Make sure all Hands and Alarm Dial are tight on their respective shafts.
4. With Alarm Set knob pulled out, continue to rotate Time Set Shaft clockwise and note that the Alarm vibrator arm drops against field core approximately 7-10 minutes later.
5. Set alarm at some other selected position and make sure mechanism actuates within limits ( $\pm 1$  minute).
6. Check alarm tone of vibrator. This can be adjusted by either bending vibrator arm nearer or farther away from field core. Bend arm near anchor point.

CLEANING AND LUBRICATION

To clean, completely disassemble and clean all moving parts in carbon tetrachloride or some similar cleaner.

The inside of the sleeves and shaft surfaces may be cleaned of oxidized oil by rubbing with a fine grade of steel wool dampened in carbon tetrachloride.

Do not use too much oil and apply by means of a small wire (drop oiler). Too much oil collects dust and later oxidizes. Use only recommended clock oil, such as Nye's Celebrated Oil which may be purchased from Wm. F. Nye Co., Inc., New Bedford, or equivalent.

CLOCK TROUBLES

1. Clock will not operate—Defective field coil, defective rotor, binding of parts.
2. Clock loses time—Binding parts, too little friction on minute hand sleeve assembly, defective rotor. Clock time-set shaft bends and rubs against hole in clock bracket.
3. Noisy Clock—Rotor defective, alarm armature improperly adjusted, loose parts, or binding of moving parts.

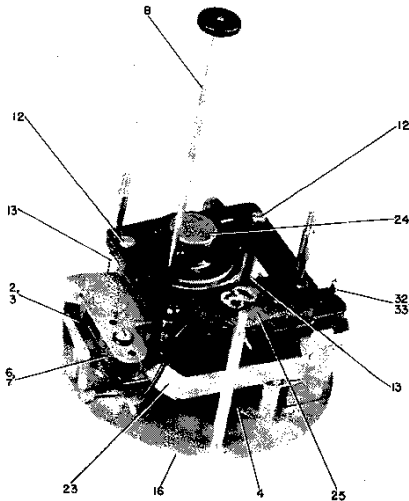

Fig. 11. Back View, C57 Clocks

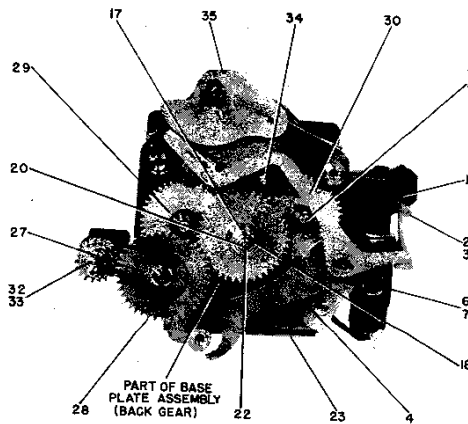

Fig. 12. Front View, C57 Clocks—Front Plate Removed

MODELS 514,  
542, 543

PARTS LIST FOR MODELS 514, 542 AND 543

Cat. No.	Symbol	Description	Unit Price	Cat. No.	Symbol	Description	Unit Price
<b>CAPACITORS (Paper)</b>				<b>MISCELLANEOUS ELECTRICAL (Cont'd)</b>			
*RCE-127	C11A, B	50-50 mf., 150 v., electrolytic	\$1.85	*RWL-116		CORD—A-c power cord and plug, ivory, for Model 543	\$0.75
RCE-062	C1A, B, C, D	Tuning, two section, 9 mmf.-135 mmf., osc., 14 mmf.-434 mmf., ant.	3.50	RZC-021		CLOCK ASSEMBLY—60 cycles, 105-125 v. for Models 542, 543	17.25
*RCW-3048	C9A, B, C, D	Four ceramic capacitors in two sections— one—.002 mf., section two—400 mmf., 220 mmf., .005 mf.	.90	*RZC-022		CLOCK ASSEMBLY—60 cycles, 105-125 v. for Model 514	13.00
RCW-3075	C2	47 mmf., ceramic	.25	<b>MISCELLANEOUS MECHANICAL</b>			
*UCC-037	C12	.003 mf., 600 v., paper	.25	RAC-102		BRACKET—Clock mounting bracket, plastic	.75
*UCC-045	C3, 4, 10	.05 mf., 600 v., paper	.30	*RDK-230		KNOB—For volume control (ivory)	.15
<b>RESISTORS (Carbon, 1/2 Watt)</b>				*RDK-246		DIAL—Tuning, brown, gold numerals; for Model 514	.60
*URD-007	R10	18 ohms	.13	*RDK-285		DIAL—Tuning, red, for Models 542, 543	.60
*URD-021	R2	68 ohms	.13	*RHC-024		CLIP—For mounting electrolytic capacitor C11	.10
*URD-029	R8	150 ohms	.13	*RHC-034		CLIP—Fastener to hold 1st and 2nd I-F transformer can to chassis	.05
*URD-081	R1	22,000 ohms	.13	*RHG-015		GROMMET—Rubber grommet used to insulate and shock mount tuning cap	.05
*URD-113	R6, 7	470,000 ohms	.13	*RHH-004		FASTENER—Snap on type for holding back to cabinet on Model 514	.02
*URD-129	R3	2.2 meg.	.13	*RHJ-005		SPACER—Metal spacer bushing in grommet mounting tuning capacitor	.02
*URD-141	R5	6.8 megohms	.13	*RHS-075		SCREW—No. 6 self tapping 3/8 in. long, used to hold chassis to cabinet	.02
<b>(Carbon, 2 Watt)</b>				*RHS-085		SHIELD—Metal tube shield for V3, 12AV6 mechanized production, see RHS-110	.15
*URF-049	R9	1000 ohms	.25	*RHS-093		SHIELD—Plastic cover over tube socket pins and terminal board (mechanized production only)	.75
<b>(Potentiometers)</b>				RHS-110		SHIELD—Metal tube shield for V3, 12AV6 nonmechanized production, see RHS-085	
*RRC-054	R4	Volume control 500,000, composition	1.25	RMC-002		CLIP—Oscillator coil mounting	.02
<b>COILS AND TRANSFORMERS</b>				*RMS-214		SPRING—Retaining ring for hub of tuning dial	.05
*RLC-118	T1	COIL—Oscillator coil	.90	<b>CABINETS AND CABINET PARTS</b>			
*RTL-135	T2, 3	TRANSFORMER—1st or 2nd I-F, with tuning cores	1.90	*RAB-150		CABINET BACK—Includes loop antenna, L1, for Models 542, 543	1.25
*RTO-099	T4	TRANSFORMER—Audio output	1.90	*RAB-151		CABINET BACK—Includes loop antenna, L1, for Model 514	1.25
<b>MISCELLANEOUS ELECTRICAL</b>				*RAG-033		CLOTH—Cabinet grille cloth, dark maroon; for Model 542	.30
*RJS-158		SOCKET—Tube socket for V2, 12BA6 mechanized, see RJS-188	.35	*RAG-034		CLOTH—Cabinet grille cloth, ivory; for Model 543	.30
*RJS-162		SOCKET—Tube socket for V1, 12BE6 mechanized, see RJS-189	.30	*RAU-338		CABINET—Brown mottle, plastic; for Model 542	4.95
*RJS-163		SOCKET—Tube socket for V3, V4, V5, 12AV6, 50C5, 35W4 mechanized, see RJS-190	.30	*RAU-339		CABINET—Ivory, plastic; for Model 543	4.95
RJS-188		SOCKET—Tube socket for V2, 12BA6 nonmechanized, see RJS-158		*RAU-348		CABINET—Mahogany mottle, plastic; for Model 514	5.45
RJS-189		SOCKET—Tube socket for V1, 12BE6 nonmechanized, see RJS-162		*RYN-005		NAMEPLATE—G-E monogram for Model 514 cabinet	.20
RJS-190		SOCKET—Tube socket for V3, V4, V5; 12AV6, 50C5, 35W4 nonmechanized, see RJS-163					
*ROP-022		LOUDSPEAKER—4-inch PM	4.90				
*RWL-009		CORD—A-c power cord and plug, brown, for Models 514 or 542	.70				

\* Used on previous receivers.

©John F. Rider

MODELS 514,  
542, 543

CLOCK PARTS LIST—FOR RADIO MODELS 514, 542 AND 543

Any item bearing a Telechron catalogue number may be procured through a Telechron Service Station. Inasmuch as radio parts and clock parts procurement procedures may differ, it is suggested you contact your General Electric Radio Distributor for assistance. All or at least those items bearing General Electric catalogue numbers may also be procured directly through the General Electric Radio Distributor.

MODEL 514 CLOCK ASSEMBLY

G.E. CAT. NO. RZC-022, TELECHRON NO. C51G22

APPEARANCE ITEMS			MOVEMENT ITEMS (Cont'd)		
Description	G.E. Cat. No.	Telechron Cat. No.	Description	Symbol	Telechron Cat. No.
Alarm Disc (Black, white figures)	RZA-013	55X48	*Base Plate Assembly	21	35X101
*Crystal-Bezel (Plastic)		58X129	*Cam Shaft Assembly	26	17X10
Dial Face (Gold and black, gold figures)	RZJ-002	61X1056	*Cam Shaft Washer	25	40X252
*Dial and Crystal Spacer (paper)		59X772	*Field and Coil	23	45X209
Hands, Hour and Minute (Black)	RZK-003	32X308	Field Screw (2)	13	1X1
*Hand, Sweep Second (Red)		31X81	Front Plate Assembly	16	34X287
*Knob, Alarm or Switch Set (Ivory)		59X716	*Hour Hand Sleeve	18	13X11
*Knob, Time Set (Bronze)		3X36	*Intermediate Gear Assembly	27	40X87
MOVEMENT ITEMS			*Minute Hand Sleeve	19	14X32
			*Rotor Unit—60 cycle	22	44X38
Description	Symbol	Telechron Cat. No.	*Spreader Post (2)	14	40X201
			*Sweep Second Hand Shaft	20	16X14
*Alarm Set Sleeve	17	15X3	*Switch Contact Assembly	4	40X322
*Alarm Set Shaft (Slotted)	31	11X43	*Switch Index Spring	28	40X185
			*Switch Lever Assembly	12	40X98
			*Switch Shaft Assembly	8	59X782
			*Switch Shaft Spacer	5	40X275
			Time Set Shaft	11	10X151
			*Time Set Shaft Spacer	9	40X276

MODEL 542 AND 543 CLOCK ASSEMBLY

G.E. CAT. NO. RZC-021, TELECHRON NO. C57G76

APPEARANCE ITEMS			MOVEMENT ITEMS (Con't)		
Description	G.E. Cat. No.	Telechron Cat. No.	Description	Symbol	Telechron Cat. No.
Alarm Disc (Red, white figures)	RZA-011	55X48	*Base Plate Assembly	23	35X93
Bezel, Outer Ring (Metal, gold color finish)		54X31	*Cam Shaft Assembly	28	17X10
Bezel, Numeral Ring (Metal, maroon, perforated numerals)	RAZ-012	53X163	*Cam Shaft Washer	27	40X252
Bezel, Numeral Color Ring (paper, ivory)		59X816	*Field and Coil (60 cycles)	25	45X209
Crystal (glass, round)	RZW-005	58X146	Front Plate Assembly	16	34X285
Dial Face (Gold color, red figures)		61X1058	*Hour Hand Sleeve	18	13X11
Hands, Hour and Minute (Black, radium treated tips)	RZK-003	32X306	*Intermediate Gear Assembly	29	40X87
Hand, Sweep Second (white)		31X103	*Minute Hand Sleeve	20	14X32
*Knob, Alarm, Sleep or Switch Set (Ivory)		59X716	*Rotor Unit—60 cycle	24	44X38
*Knob, Time Set (Bronze)		3X36	*Sleep Switch Shaft	35	40X308
MOVEMENT ITEMS			*Sleep Switch Lever Assembly	30	40X194
			*Sleep Switch Friction Assy.	34	40X196
Description	Symbol	Telechron Cat. No.	*Spreader Post (2)	13	40X201
			*Sweep Second Hand Shaft	22	16X14
*Alarm Set Sleeve	17	15X3	*Switch Contact Assembly	7	40X322
*Alarm Set Shaft (Slotted)	33	11X41	*Switch Index Spring	11	40X185
			*Switch Yoke Lever	4	40X197
			Switch Shaft Assembly	3	59X780
			*Switch Shaft, Spacer	1	40X275
			*Time Set Shaft	8	10X141
			*Time Set Shaft Spacer	9	40X276

\*Used on previous General Electric radio clocks