

THE TELEVISION HANDBOOK

LOOK

and

LISTEN

THE TELEVISION HANDBOOK

LOOK AND LISTEN

Including:

Detailed Instructions for Building
an Andrea Sight-and-Sound Receiver

by M. B. SLEEPER

Founder and Editor of Radio Engineering Magazine, author
of Radio Design Practice, and many other radio books,
and actively identified with the radio industry since 1916

FIRST EDITION

JULY, 1939

Printed in U.S.A.

ACKNOWLEDGMENTS

THE PRESENTATION OF THE DETAILED INFORMATION ON THE ANDREA TELEVISION EQUIPMENT WAS MADE POSSIBLE THROUGH THE COOPERATION OF THE ANDREA RADIO CORP. AND ITS TELEVISION ENGINEERING STAFF. PHOTOGRAPHS OF W2XBS AND ITS EQUIPMENT ARE PRESENTED BY THE COURTESY OF THE NATIONAL BROADCASTING COMPANY. OTHER STATIONS WILL BE SHOWN IN FUTURE EDITIONS OF THIS BOOK.



DOROTHY DEY, BROADWAY-PARK AVENUE COLUMNIST, WATCHING RECEPTION ON AN ANDREA TELEVISION-BROADCAST-PHONOGRAPH COMBINATION. MISS DEY, WHO REPORTED THE ENGLISH CORONATION FOR AMERICAN NEWSPAPERS, SAID, AFTER WATCHING THE BAER-NOVA FIGHT AT THE TELEVISION ROOM OF THE HOTEL AMBASSADOR: "I BELIEVE THAT TELEVISION IN THE U.S.A., UNDER PRIVATE OWNERSHIP, WILL MAKE MORE PROGRESS IN SIX MONTHS THAN HAS BEEN MADE IN ENGLAND, UNDER GOVERNMENT OPERATION, DURING THEIR FIRST TWO YEARS."



FIG. 1. FELIX THE CAT, NBC'S ORIGINAL TELEVISION GUINEA PIG, AS SEEN IN A 1938 MODEL TEST RECEIVER.

INTRODUCTION

Television: A newly-created field of unlimited opportunity for radio Students, Set-Builders, Experimenters and Servicemen

The date of April 30, 1939, on which the New York World's Fair opened, will be remembered long after the last vestige of the Fair has disappeared, for that date marked the official inauguration of scheduled television programs in the United States.

But many other events will trace their beginnings to that date. It is certain that television will bring vast and far-reaching changes in the radio manufacturing industry. Television will probably mark the beginning of the end of some concerns, and the establishment of newcomers in the field.

It does not appear that television will affect straight sound broadcasting, as talking movies have superseded the silent pictures. In the theatre, the audience, presumably, gives undivided attention to the show, while in the home, the enjoyment of straight sound programs does not interfere with

carrying on household tasks, conversation, and bridge games. Rapid-fire news reporting does not lend itself to illustration, and the many people who choose to do their reading to soft musical accompaniment would not want their eyes diverted by the television screen.

On the other hand, the establishment of television as a permanent service, to be as much a part of our daily life as straight sound broadcasting has become, is accepted as a certainty by those who, having grown up with the new art, are cognizant of its great scope and possibilities. This, of course, refers to television in the U.S.A., for the forecasting of progress in any new industry must take into account the buying power and spending habits of the people where its products are to be introduced, the facility of purchasing on time-payments, the

FIG. 2. STUDIOS, LABORATORIES, AND FACTORIES WILL REQUIRE ENGINEERS TO OPERATE, MAINTAIN, AND DEVELOP AND TEST TELEVISION TRANSMITTING AND RECEIVING EQUIPMENT.

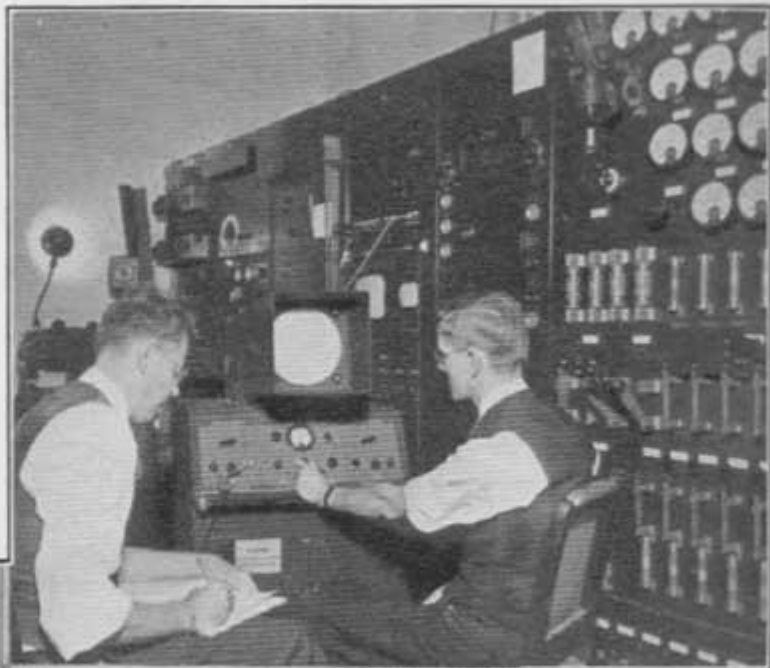
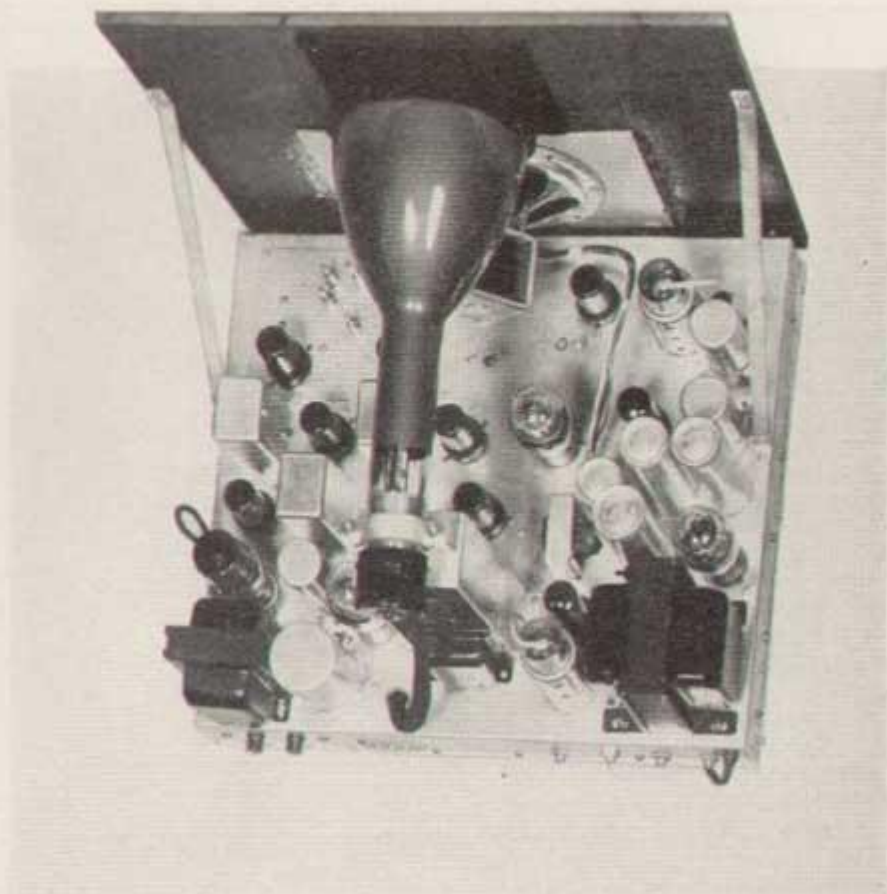

FIG. 3. CONTROL ROOM, NBC STUDIOS. ENGINEER IN FOREGROUND MONITORS SOUND FROM STUDIO MICROPHONES; AT FAR END IS THE VIDEO MONITOR; CENTER, PROGRAM DIRECTOR, FACING TALK-BACK MIKE, INSTRUCTS TELEVISION CAMERA MEN, WEARING HEADPHONES, IN STUDIO.

aggressiveness of sales promotion and merchandising methods, the availability of distribution means, and the number and location of population centers and the markets they represent.

All these factors in the U.S.A. are

favorable to the development of television broadcasting and the sale of television receivers. It is reasonable to expect, therefore, that capital will be made available for the erection of stations throughout the country, for the mass production of receivers, and



THE TELEVISION HANDBOOK

LOOK AND LISTEN

BY M. B. SLEEPER

DESCRIBING 1939 TELEVISION PRACTICE, FOR
SERVICE MEN, SET BUILDERS, AND STUDENTS

COPYRIGHT 1939, AND PUBLISHED BY

THE NORMAN W. HENLEY PUBLISHING CO.

2 WEST 45th STREET, NEW YORK, N. Y.

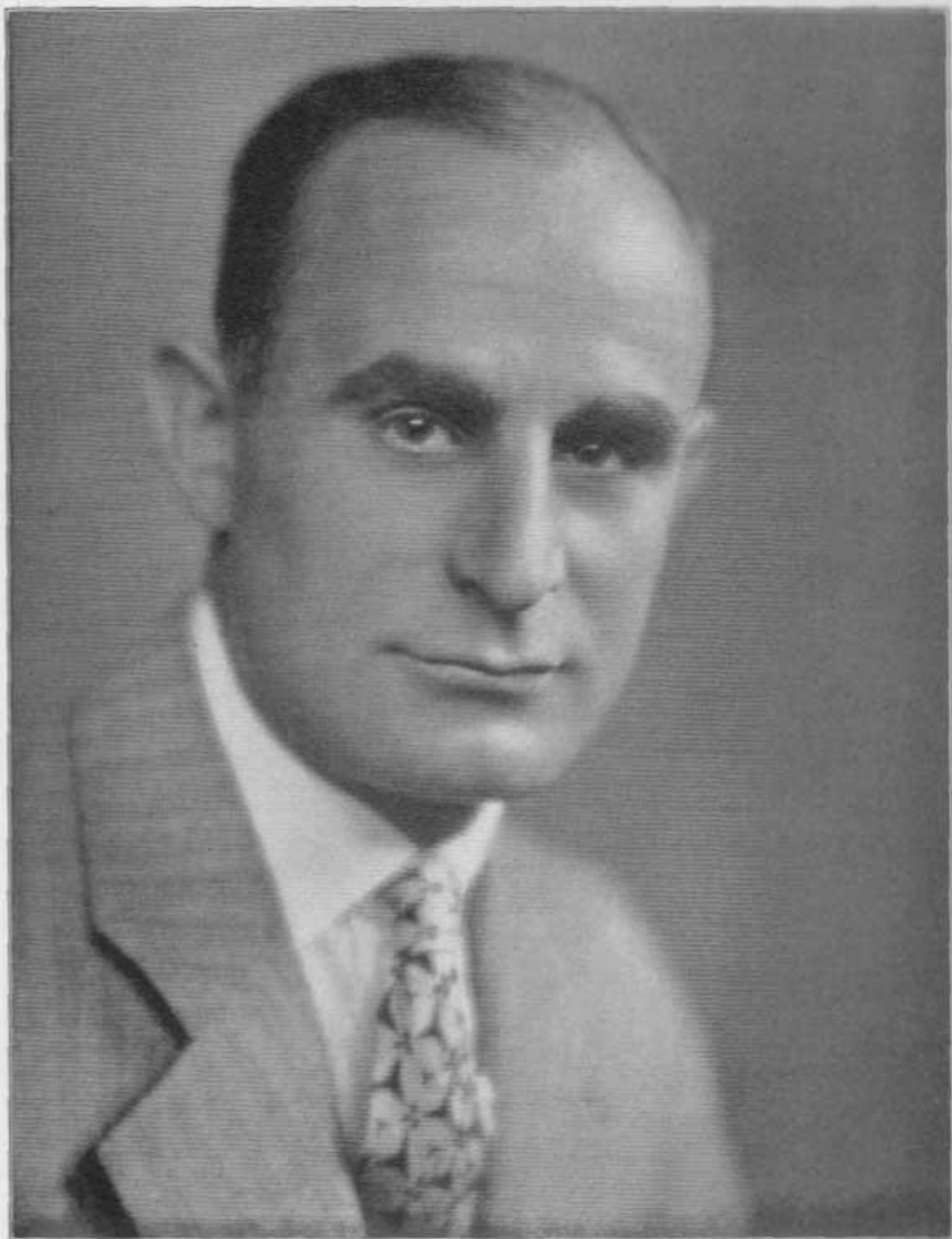

FRANK A. D. ANDREA

RADIO PIONEER WHO, SINCE 1919, HAS OCCUPIED A LEADING POSITION IN THE RADIO FIELD; WHO, IN 1923 INTRODUCED THE NEUTRODYNE RECEIVER; WHO IS KNOWN IN EVERY COUNTRY OF THE GLOBE FOR THE MUSICAL QUALITY AND STAMINA OF THE RADIO RECEIVERS HE PRODUCES; AND WHO, IN 1939, WAS THE FIRST RADIO MANUFACTURER TO MARKET A LINE OF SIGHT-AND-SOUND TELEVISION RECEIVERS.

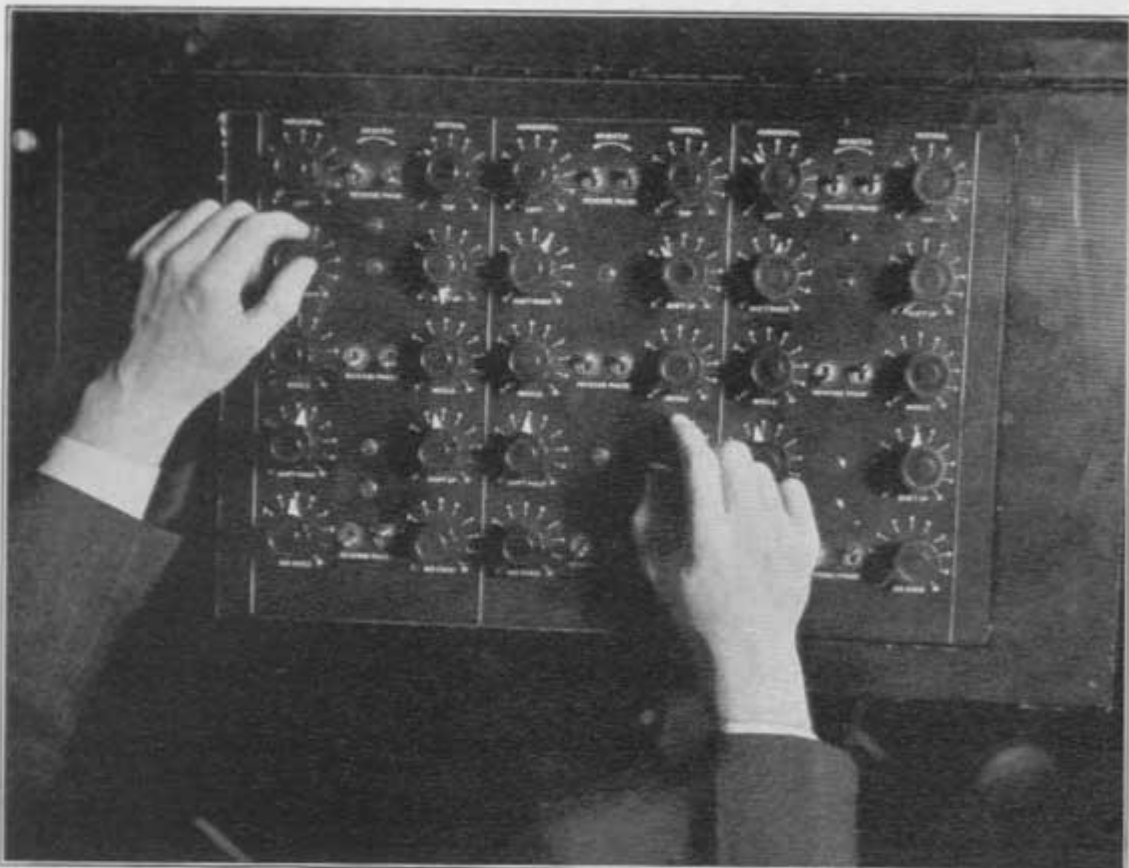

FIG. 7. THIS THREE-SECTION SHADING PANEL IN THE CONTROL ROOM IS CONNECTED TO THREE TELEVISION CAMERAS. THERE ARE TEN CONTROLS AND SIX SWITCHES IN EACH SECTION, TO BE HANDLED WITH UNFALtering ACCURACY, TO CORRECT FAULTS WHICH MAY APPEAR IN THE PICTURE.

people who lacked a standard of tone quality to show up the inferior reproduction provided by those little rat-trap sets.

Perhaps there will be further improvements in broadcast receivers which will eliminate the handicap from the presence of the now-prevailing background noise. Perhaps sound broadcasting will capitulate gradually to the ultra-frequency bands, if channels can be made available for that purpose.

In either case, present-day sound broadcast receivers will be made obsolete when and if either of these improvements materializes. How long it will be until either possibility becomes a reality, no one can hazard even an intelligent guess. It is possible that Major Armstrong's substitution of frequency modulation for the conventional amplitude modulation may initiate the shift of sound programs from the present broadcast frequencies to the ultra-high frequency chan-

nels. Some engineers believe that the freedom from fading and from interference is an inherent quality of ultra-high frequencies, and not a unique characteristic of frequency modulation. A further element of uncertainty as to the potentialities of Major Armstrong's system is introduced by the fact that signals from his type of transmitter cannot be picked up by conventional receivers now in use.

What we do know beyond the shadow of a doubt at this time of writing is that the entire radio industry, including the manufacturers of transmitting and receiving equipment, the broadcasting companies, as well as the distributing organizations and the retail stores and even the service men, is coming into an entirely new phase of its existence. A part of the set-up will readjust itself during this period of flux. Some of the established organizations will be replaced by those not yet in existence.

Perhaps the tube manufacturers alone can plan with certainty to profit by whatever changes come about, for the versatile vacuum tube seems to be an essential part of all radio equipment, and has adapted itself, or contributed to, each new development by the mere addition or reshaping of elements.

This situation is again setting the stage for the advance guard of stock promoters. They recall the early days of radio activities as harvest time for garnering their dubious profits, and they know that hope springs eternally in the heart of the avid-minded buyer of engraved certificates. The SEC may deter the out-and-out swindler who would capitalize on the tremendous public interest in television, but ample opportunity will be given those who would get rich quickly to gamble on projected television companies that lack even the elements of potential success. The record of radio set manufacturers promoted by brokers at the beginning of broadcasting should be scrutinized carefully by anyone contemplating an investment in television stock!

Looking down upon the seething activities touched off by the inauguration of scheduled television transmission is the FCC, its hand upon the switch of all radio's stop-and-go signals. Until now, the rulings of the FCC have been regulatory in their nature. With the advent of television on a national scale, requiring the adoption of universal standards so that all receivers will operate with all transmitters, the FCC has come into a new power of control. Called upon to establish standards for television transmission and reception, so that the manufacturers can proceed with confidence that there will be no more than a reasonable degree of obsolescence, the FCC has been decidedly reluctant to act. They have taken the position that to reach a decision hastily might eliminate the development of some superior system, and at the same time give, in effect, a monopoly to those manufacturing the equipment now in use.

This is, indeed, a serious matter, and it is to be hoped that the Commission may reach a decision which will give immediate encouragement to commercial television, and at the same time leave the door open to any new system of demonstrable superiority. The Commission's investigation has been conducted in a most thorough manner, and has included not merely conferences with all the companies concerned, but personal visits to inspect plants and equipment, and exhaustive examinations into the present status of the art.

As if this situation were not sufficiently difficult of solution, the added aspect of political implications has been introduced by the current administration. The FCC may now consider not only what constitutes the convenience and necessity to the public, but to the administration as the political representatives of the people.

The general public does not realize that any radio station exists today only under the permissive approval of the FCC. While the transmitting licenses of broadcast stations are renewed as a matter of routine, any renewal can be withheld pending the outcome of a hearing as to the continuation of the station. It is easy to understand that it could be made difficult or even impossible for a station to show why it should be granted a renewal of its license, if its policies are found inimicable to the interests of the administration as the representatives of the public.

From the foregoing, it is clear to see that the entire radio situation has been projected into a state of flux. There will be far-reaching changes, revisions and developments, as the result of which radio is becoming again a field of great opportunity for the student, experimenter, set-builder, or serviceman who prepares himself, through experience and serious study, to contribute to this new phase of progress.

M. B. SLEEPER.

July, 1939.

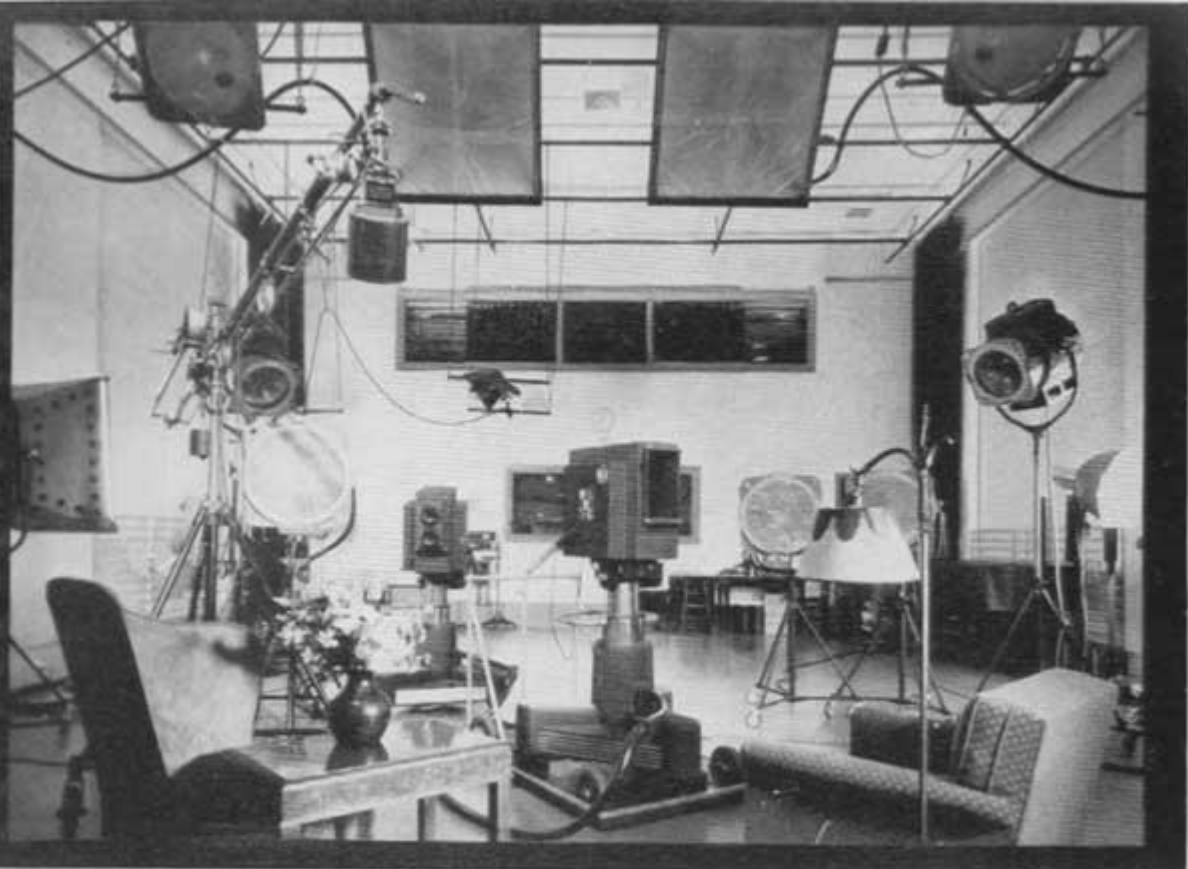

FIG. 5. AN NBC TELEVISION STUDIO. MUCH OF THE EQUIPMENT HAS BEEN ADAPTED FROM SOUND BROADCASTING AND MOTION PICTURE APPARATUS.

CHAPTER ONE

The uncharted field of television development which seems to lead toward a complete revision of radio and motion picture entertainment

Because the advent of television has brought about so many upsets, and has created so many new problems for both manufacturers and broadcasters, many executives in the radio business have undertaken to show that television is still nothing more than a scientific novelty, incapable of providing any national service.

Location of Transmitters: Much emphasis is put upon the fact that the transmitting radius of a television station is limited to 50 miles. Practical experience already indicates that, with the increase in power which will be provided later, the range will exceed the theoretical limit of 50

miles. But suppose television programs can't be sent over a greater distance than that. Then how many stations will be needed to serve a reasonable percentage of our U. S. population?

We know that there are over 770 straight sound transmitters in this country, but we cannot expect the erection of that many television stations within the next year or two. What, then, would be a reasonable plan for the distribution of, let us say, 100 television stations?

The logical guide would be the figures on U. S. population centers, issued by the Department of Commerce. So that you can

Television Transmitters Will Probably Be Located in These Population Centers

Akron, O.	347,000	Milwaukee, Wis.	743,000
Albany, Schenectady, Troy, N. Y.	425,000	Minneapolis, St. Paul, Minn.	832,000
Allentown, Bethlehem, Easton, Pa.	322,000	Nashville, Tenn.	209,000
Altoona, Pa.	114,000	New Haven, Conn.	294,000
Atlanta, Ga.	371,000	New Orleans, La.	495,000
Atlantic City, N. J.	102,000	New York, Northeastern N. J.	10,901,000
Baltimore, Md.	949,000	Norfolk, Portsmouth, Newport News, Va.	273,000
Binghamton, N. Y.	130,000	Oklahoma City, Okla.	202,000
Birmingham, Ala.	383,000	Omaha, Neb., Council Bluffs, Ia.	274,000
Boston, Mass.	2,308,000	Peoria, Ill.	145,000
Bridgeport, Conn.	204,000	Philadelphia, Pa.	2,847,000
Buffalo, Niagara Falls, N. Y.	821,000	Pittsburgh, Pa.	1,954,000
Canton, O.	191,000	Portland, Ore.	370,000
Charleston, W. Va.	108,000	Providence, R. I., Fall River, New Bedford, Mass.	964,000
Chattanooga, Tenn.	119,000	Racine, Kenosha, Wis.	133,000
Chicago, Ill.	4,365,000	Reading, Pa.	170,000
Cincinnati, O.	759,000	Richmond, Va.	221,000
Cleveland, O.	1,195,000	Roanoke, Va.	103,000
Columbus, O.	340,000	Rochester, N. Y.	399,000
Dallas, Texas	310,000	Rockford, Ill.	103,000
Davenport, Ia.	155,000	Sacramento, Cal.	127,000
Dayton, O.	252,000	St. Louis, Mo.	1,294,000
Denver, Colo.	331,000	Salt Lake City, Utah	184,000
Des Moines, Ia.	161,000	San Antonio, Texas	279,000
Detroit, Mich.	2,105,000	San Diego, Cal.	181,000
Duluth, Minn.	155,000	San Francisco, Cal., Oakland, Cal.	1,290,000
El Paso, Tex.	118,000	San Jose, Cal.	103,000
Eric, Pa.	130,000	Savannah, Ga.	105,000
Evansville, Ind.	123,000	Seranton-Wilkes-Barre, Pa.	652,000
Flint, Mich.	180,000	Seattle, Wash.	421,000
Fort Wayne, Ind.	127,000	South Bend, Ind.	147,000
Fort Worth, Tex.	175,000	Spokane, Wash.	129,000
Grand Rapids, Mich.	207,000	Springfield, Holyoke, Mass.	399,000
Harrisburg, Pa.	162,000	Syracuse, N. Y.	245,000
Hartford, Conn.	471,000	Tacoma, Wash.	147,000
Houston, Tex.	339,000	Tampa, St. Petersburg, Fla.	169,000
Huntington, W. Va., Ashland, Ky.	163,000	Toledo, O.	347,000
Indianapolis, Ind.	418,000	Trenton, N. J.	190,000
Jacksonville, Fla.	149,000	Tulsa, Okla.	183,000
Johnstown, Pa.	148,000	Utica, N. Y.	191,000
Kansas City, Kans., Kansas City, Mo.	608,000	Washington, D. C.	621,000
Knoxville, Tenn.	136,000	Waterbury, Conn.	141,000
Lancaster, Pa.	123,000	Wheeling, W. Va.	191,000
Little Rock, Ark.	113,000	Wichita, Kansas	119,000
Los Angeles, Cal.	2,319,000	Wilmington, Del.	164,000
Louisville, Ky.	404,000	Worcester, Mass.	305,000
Lowell, Lawrence, Mass.	332,000	Youngstown, O.	367,000
Memphis, Tenn.	276,000		
Miami, Fla.	132,000		

see if you may be within range of a transmitter in the near future, the official list of centers, together with their population, is given on page 12. The population is roughly limited to a radius of ten miles. The figures would be increased greatly if they were based on a 50-mile radius. In fact, stations in the 96 cities listed would

serve about 80 per cent of the homes equipped with A.C. current!

Obviously, therefore, this explodes the claim that a reasonably small number of stations, less than 100, can not perform a national service. In fact, if you are within 50 miles of a city included in the list of population centers, it is very likely that you

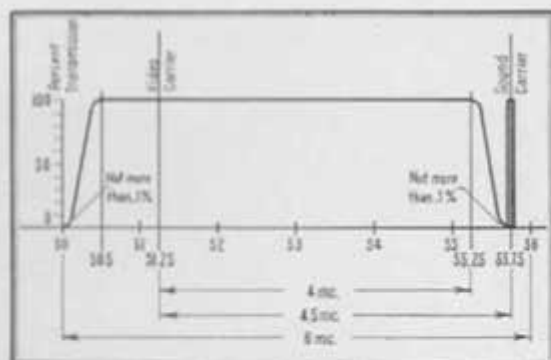

FIG. 9. PRESENT R.M.A. STANDARD TELEVISION VIDEO AND AUDIO WAVE FORM.

will have television programs in your home by the end of 1940.

Television Frequency Channels: Of the frequency channels which have been set aside for television transmission, the first two are already used by several stations, the third will be used in the near future, while the last two are, at the present time, of undetermined value:

44-50 mc.	6.82 - 6.00 meters
50-56 mc.	6.00 - 5.36 meters
66.72 mc.	4.55 - 4.17 meters
78.84 mc.	3.85 - 3.57 meters
84.90 mc.	3.57 - 3.33 meters

From this table you will see that a television channel is 6 mc. (6,000 ke.) wide, in contrast to a sound broadcast channel which is only 10 ke. wide. In fact, the whole tuning range of a broadcast receiver, 550 to 1,750 ke., is only 1.2 mc. wide. Thus the range of frequencies required for a single television station is five times the range required for all the broadcasting stations in the U.S.A. Since channels 6 mc. wide are available only at ultra frequencies, television transmitters must operate in this comparatively unfamiliar part of the radio spectrum.

Receiving phenomena at ultra-frequencies are as little understood as the short waves (below 200 meters) were in the early days of radio broadcasting. There was much theoretical knowledge, but relatively little practical experience. In 1920, it was considered certain that short waves had no commercial value. It was in 1931 that the author wrote the first advertising copy ever printed which described the now conventional all-wave, switch-controlled receiver! In the eight years following, world-wide short-wave communication has become the

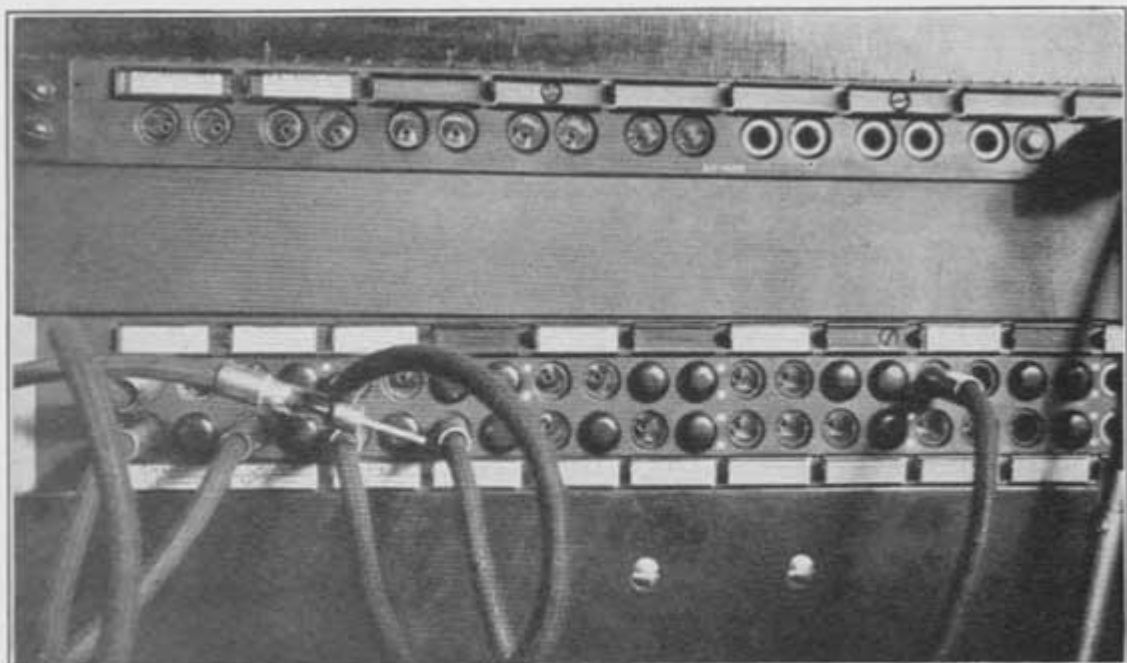

FIG. 10. JACKS FOR COAXIAL CABLE CIRCUITS. THE COST OF RUNNING THIS CABLE NOW LIMITS THE INTERSTATION DISTRIBUTION OF TELEVISION PROGRAMS. THIS DISTRIBUTION PROBLEM IS NOW ONE OF THE LIMITING FACTORS IN THE DEVELOPMENT OF COMMERCIAL PROGRAM PLANS.

FIG. 11. MISS BETTY GOODWIN, NBC TELEVISION STAR, PHOTOGRAPHED AT THE STUDIO WHILE SHE WAS BEING TELEVIEWED.—FIG. 12. BELOW, AN NBC STUDIO PRESENTATION OF "THE NINE LOVES OF EMILY." EITHER CAMERA CAN BE FADED IN AT THE CONTROL BOARD IN THE MONITORING BOOTH. ONE CAMERA IS FOR FAR SHOTS, AND THE OTHER FOR CLOSE-UPS.



newest and most powerful instrument of international political influence.

Today, at the threshold of the commercial use of ultra frequencies, who can predict the useful purposes which may be found for

the unexplored channels which now seem to be of limited adaptability to commercial applications?

Transmitting Range: Theoretically, ultra frequency waves are considered to travel





FIG. 13. THIS IS MISS BETTY GOODWIN AS SHE APPEARED AT THE PICTURE TUBE OF A TELEVISION RECEIVER. THE SLIGHT LATERAL DISTORTION IS ONLY NOTICEABLE BY COMPARISON WITH THE DIRECT SHOT SHOWN IN FIG. 11. —FIG. 14. BELOW, ANOTHER PLAY BEING TELEVIEWED AT THE NBC STUDIO. THE TECHNIQUE OF PRESENTING TELEVISION PLAYS IS BEING MADE THE SUBJECT OF EXHAUSTIVE RESEARCH.

from the transmitting antenna in a horizontal direction, that is, in a plane somewhat tangent with the earth's surface. It is said that the receiving sets must be within line-of-sight of the transmitter in order to re-

ceive ultra-frequency transmission. If the receiver is below the horizon, or hidden by intervening hills or buildings, reception is, theoretically, impossible. However, we know already, from practical experience, that this

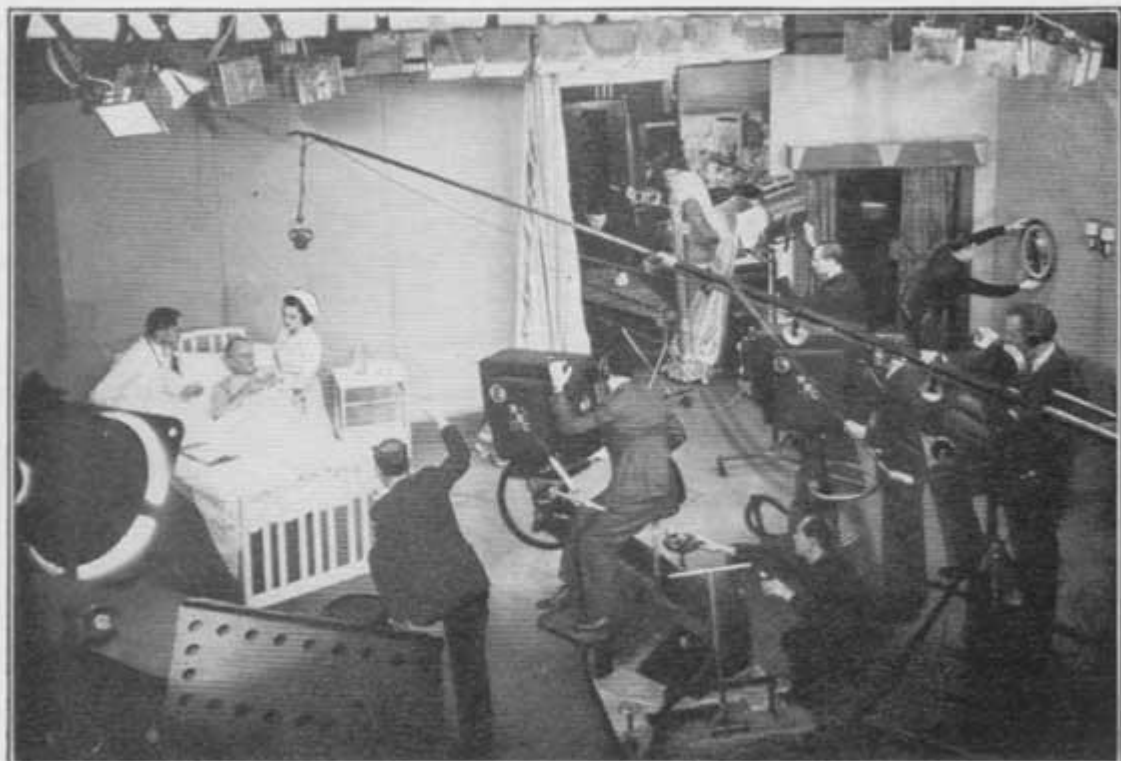

FIG. 15. MAKE-UP FOR THE TELEVISION STUDIO IS JUST AS IMPORTANT AS IT IS ON THE MOVIE LOT, AND FOLLOWS THE SAME GENERAL PRACTICES. HOWEVER, THE TELEVISION CAMERA GIVES COLORS SOMEWHAT DIFFERENT, AND SOMETIMES SURPRISING, BLACK-AND-WHITE VALUES WHEN THEY ARE SEEN IN THE RECEIVING TUBE.



is not strictly true. We know, for example, that television images from London are sometimes picked up quite clearly on Long Island!

Most ultra-frequency transmission has been done on very low power. As high-power transmitting apparatus is developed, we may find that the present maximum radius, now considered to be 40-50 miles, may be extended greatly. When we can build high-efficiency television transmitters of 25 to 50 kw. output, comparable to the larger sound broadcasting stations, we may revise completely our present ideas of distance limitations.

Advertising Value: The development of television will be determined largely by its value as an advertising medium. First, it will be necessary to produce and to reproduce at receiving sets programs of sufficient entertainment and interest to attract a large audience. If that can be done, then support of commercial sponsors will be assured, and the progress of the television art will be more rapid, even, than was that of sound broadcasting.

Right now, advertisers are only awaiting the opportunity of testing this new medium—television—for they know that an impression given to the brain through the eye is registered more quickly and is retained longer than when it is transmitted through the ear alone. There again, however, are factors which can be resolved only by practical experience. Against television we have the competition of newspapers and magazines, the gregarious instinct that sends people out of their homes to theatres for



FIG. 16. FIRST RECEIVING INTERLACE, FORMED BY SCANNING EVERY OTHER LINE. INTERLACED SCANNING ELIMINATES FLICKER.



FIG. 17. GREAT SKILL, LONG EXPERIENCE, AND THE MOST PAINSTAKING REHEARSALS ARE REQUIRED OF THE OPERATORS AND ACTORS. THE EQUIPMENT MUST, OF COURSE, BE KEPT OUT OF RANGE OF THE CAMERA AT ALL TIMES. THIS IS A SCENE FROM AN NBC PLAY, TRANSMITTED FROM STATION W2XBS.

entertainment, and the practical limitation, in a busy world, on the number of hours that people can spend looking into television receivers. The determination of these factors by practical experience will measure the future importance of television in our daily lives.

Television Standards: Public interest will depend very largely upon the quality of television reception. Based largely upon more than two years' experience with scheduled program transmission in England, certain

standards have been adopted for television transmission in the U.S.A. Although, at the time of writing, no standards have been adopted by the FCC, our standards have been accepted by those concerned with broadcasting. Andrea Radio Corporation, the first of the licensees' group to put television sets on sale in this country, is manufacturing sets to these specifications, as well as R.C.A. which followed Andrea by some two months.

The standard specifications as of April 30, 1939, are:

441 lines per frame.

30 frames per second, 2:1 interlaced. Field frequency 60.

Negative modulation, i.e., white spot is produced by minimum signal amplitude.

3:4 picture aspect ratio.

6 mc. channel width.

Video carrier 1.25 mc. above the low-frequency end of the channel.

Audio carrier .25 mc. below the high-frequency end of the channel.

Horizontal polarization.

Since there is considerable latitude for improving picture quality within these signal



FIG. 18. THE COMPLETED FRAME, COMPRISING THE FIRST INTERLACE, FOLLOWED BY THE SECOND INTERLACE SCANNING.

FIG. 19. MISS PATIENCE, AS SEEN IN THE PICTURE TUBE OF A TELEVISION RECEIVER.—FIG. 20. BELOW, MISS PATIENCE NEVER FALTERS UNDER THE WITHERING HEAT AND GLARE OF THE STUDIO LIGHTS, EVEN DURING PROLONGED TEST TRANSMISSIONS. SHE'S A BEAUTIFUL BUT DUMMY FIGURE!



specifications, it seems reasonable that they will be continued for an indefinite time to come.

Producing Picture Impulses: Essentially, a television transmitter is a means for converting various light values into electrical impulses, while the receiver provides a variable light source under control of the electrical impulses transmitted.

The underlying principles are relatively simple, but a complete exposition of the functioning of the circuit elements involved is a mathematical study far beyond the scope of this volume.

Here is a simple way to understand the method of producing television signals: Put a picture from a magazine on a table, and cover a part of it with a sheet of plain

paper. Then cover the rest of the picture with a second sheet of paper, bringing the edges of the two sheets together until there is a space between them of about $1/16$ in. Only a narrow strip of the picture will be exposed, and as your eye travels from left to right, the strip will appear as a single line of varying shades.

But suppose that, instead of looking at the whole strip at one time, you were looking through a pin-hole. Then you would see just a round dot, changing to various light and dark values as you moved it along the horizontal strip of picture.

Now suppose that, instead of registering the changing light values on your eye, you held a photo-electric cell over the pin-hole. When a photo-electric cell is exposed to light, a tiny electric current is generated. The stronger the light, the greater the current set up in the cell. As you move the photo-electric cell and the pin-hole over the strip of picture, a varying current would be set

up, according to the light and dark shadings along that part of the picture.

There you have the elements of a television camera. When the camera is pointed at a scene, or an object, or a single frame of a motion picture film, it does not register the complete view at one time. Not at all!

In effect, only a pin-hole part of the scene is viewed by the camera, and the amount of light represented by that tiny part of the scene is registered by the current from a photo-electric cell. We say that the camera "scans" the scene. That is, to use our mechanical analogy, the pin-hole is moved in a horizontal line, causing a varying current to flow from the photo-electric cell in accordance with the changing light values of that "line" of the scene.

At the end of the line, the action is stopped until the "pin-hole" returns to the side on which it started, and is ready to scan the next line of the scene. We say that the television picture is formed by 441 lines,



FIG. 21. THIS IS THE NBC EQUIPMENT USED FOR SPOT NEWS EVENTS, SUCH AS TELEVISIONING THE ENGLISH KING AND QUEEN DURING THEIR VISIT TO NEW YORK CITY, AND THE NOVA-BAER FIGHT. PROGRAMS ARE SENT TO THE EMPIRE STATE BUILDING, AND REBROADCAST ON 44-50 MC.



FIG. 22. TELEVISIONING A GROUP AT NIGHT ON THE STEPS AT ROCKEFELLER PLAZA. ALREADY THE TELEVISION CAMERA IS SUFFICIENTLY PERFECTED TO PICK UP SCENES UNDER UNFAVORABLE LIGHT CONDITIONS, AND CAMERAS OF STILL NEWER DESIGN ARE BEING TESTED.

and that is literally true, for the view is scanned from top to bottom by the movement of the "pin-hole" in 441 successive lines.

So much, at present about the transmitter. Now, for the receiver. Suppose that you have a controllable source of light, the size of the hole we have been talking about, and an arrangement that will move the tiny light in horizontal lines, exactly in step with the scanning hole at the transmitter. And imagine that the changing current set up in the transmitting photo-electric cell controls the amount of light at the receiver.

If you move the pin-hole at the transmitter fast enough to scan the scene before the camera in 441 lines with 30 complete scannings per second, your tiny spot of varying light at the receiver, traveling in unison, will form light pictures at the receiver which reproduce the scenes and motion before the television camera.

Replace the pin-hole scanner and the photo-electric cell with the television camera

controlling the impulses of a radio transmitter, add a radio receiver controlling a picture tube in place of the moving dot of variable light, and you have the essential elements of a complete television system.

The fundamentals of the system are simple enough. Yet the means for putting them into operation, and maintaining unflinching synchronism between the scanning of the scene and the movement of the light source at the receiver are so highly complex, and so amazingly ingenious as to prompt an experienced designer of sound broadcast equipment to remark to the author: "The more I learn about the theory and mathematics of television, the more convinced I become that it's all impossible!"

And that will explain why this volume has been kept to the simple and practical aspects of television transmission and reception.

Interlaced Scanning: The simplest method of scanning a scene would seem to be that of starting at the top, scanning the



FIG. 23. ANOTHER PIECE OF NBC STUDIO EQUIPMENT. THIS IS THE MACHINE WHICH PROJECTS FILM INTO THE CAMERA, FOR TRANSMITTING MOVIES. THERE IS LESS FLICKER AT THE TELEVISION PICTURE TUBE THAN WHEN FILM IS SEEN ON THE SCREEN IN A THEATRE.

first line from left to right, then scanning the next line from right to left, and so on down. In practice, however, it was found that when succeeding lines were scanned in opposite directions, the adjacent lines did not match perfectly. Consequently, the present uni-directional method of scanning was adopted, in which 90 per cent of the time allowed between lines is devoted to the line scanning, and 10 per cent to the return trace, in preparation for starting the next line. The total time for the line scanning and retrace is

$$\frac{1}{441 \text{ lines} \times 30 \text{ frames}} = \frac{1}{13,230} \text{ second}$$

The return trace cannot be seen in the picture tube, since it is blanked out by a blanking signal from the transmitter. By this manner of transmission, a picture would be formed as indicated in Fig. 18, where one line follows immediately below the preceding line.

Further investigations, however, showed that the pictures could be improved by reducing the flicker, noticeable when film is projected on a screen, if the pictures were scanned by the interlace method. In this new method, now standard practice, every other line is scanned, as in Fig. 16. That is, line 1, then 3, 5, 7 and so on. This comprises



FIG. 24. THE ANDREA KT-E-5 CHASSIS CAN BE MOUNTED IN THIS MANNER FOR MIRROR VIEWING. CONTROLS AT THE TOP ARE FOR THE TELEVISION SET, AND AT THE FRONT, FOR AN ALL-WAVE SOUND RECEIVER. THIS MAKES A MOST ATTRACTIVE PIECE OF FURNITURE.

the first interlace. Then lines 2, 4, 6, 8 and so on are scanned, making the second interlace. This completes the picture, as shown in Fig. 18.

As a result of this interlaced scanning method, television reception is practically free of flicker, and is easier on the eyes than motion pictures.

Negative Modulation: In the U.S.A., we use negative reception, which is exactly opposite from the practice in England, and an improvement over their system, as demonstrated by practical experience.

That is, in the U.S.A. the whitest parts of the received image are formed when the amplitude of the transmitted signal is zero,

and the black parts when the signal is at 80 per cent of maximum. The 20% remainder of the signal amplitude, called the blacker-than-black portion, is used for blanking and synchronizing signals.

Aspect Ratio: The aspect ratio is the relation of the height of the transmitted picture to the width. Thus you will notice that when the picture size of a television receiver is given accurately, the ratio of the height to the width is 3:4. If the dimensions are adjusted to any other ratio, the picture is either cut down by the mask at the front, or else it is distorted.

Channel Width: The established width of a television channel is 6 megacycles (mc.)

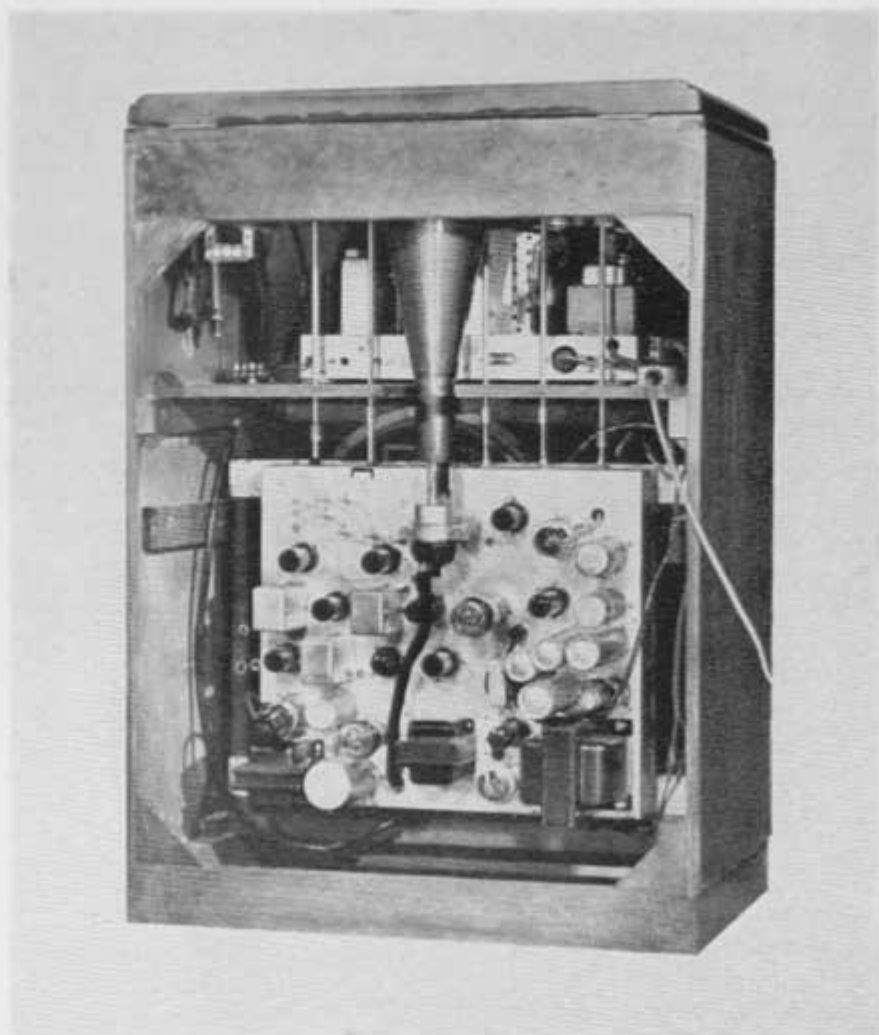

FIG. 25. TO MOUNT THE CHASSIS VERTICALLY, IT WAS ONLY NECESSARY TO MODIFY THE HEIGHT OF THE PICTURE TUBE BRACKET, AND TO PUT EXTENSION RODS ON THE SIX CONTROLS. THIS SHOULD OFFER SOME SUGGESTIONS TO THE CUSTOM SET BUILDERS, FOR MEETING SPECIAL SITUATIONS.

or 6,000,000 cycles. This includes the picture-modulated video carrier, and the sound-modulated audio carrier, as shown in Fig. 9, illustrating the 50-56 mc. band. From this, you will see that a television station has two separate transmitters, which use separate antennas. A 44-50 mc. station, for example, uses one transmitter with a carrier frequency of 45.25 mc., with one side-band substantially suppressed, for video. Then, there is a second transmitter, operating on a carrier frequency of 49.75 mc., for the sound.

Horizontal Polarization: In England, vertical polarization is employed for television transmission. That is, the signal is

fed to the center of a vertical radiator. Accordingly, the receiving antennas are vertical, with the leads coming from the center. Experience has shown that the vertical antenna is more responsive to automobile ignition interference than the horizontal antenna. Accordingly, in the U.S.A. we are using horizontal transmitting antennas, or horizontal polarization, with similarly positioned receiving arrangements.

Improved Equipment: The television audience can expect great improvements in the transmitting equipment within the next two years. This applies to the radio frequency apparatus, as well as to cameras and their associated controls. Some of the first

of the television receivers to be put on the market are equipped for five television tuning bands, yet we know nothing, from practical experience, about transmitters for 75 to 90 mc. other than experimental types of a few watts output.

At the moment, television on frequencies above the 44-50 and 50-56 mc. channels remain to demonstrate their effectiveness. The advisability of supplying other bands in receiving sets is open to question. Even the 44-50 and 50-56 mc. transmitters do not yet compare in efficiency with the stations on broadcast frequencies.

We know that ultra-frequency transmission is not limited to the theoretical line-of-sight range. How much it can be increased over the present estimated 40 to 50-mile radius by the brute force of higher power we cannot tell until transmitting equipment of greater output has been developed and put into operation.

Orin E. Dunlap, Jr., writing in the *New York Times* on May 7th, 1939, one week after the official inauguration of scheduled television programs in the U.S.A., said of the initial transmission at the World's Fair: "Within two hours outdoors, under a bright April sun that played hide and seek among the clouds, the television engineers, camera crew, and showmen learned more about winged pictures than they had in months of preparation in the studios and in the mobile vans."

Such is the present status of the art as to the skill of the operators as well as their equipment. Certainly, it is reasonable to expect great and rapid improvement over the initial programs. The first rebroadcast pictures, picked up by the mobile unit illus-

trated here, were far from satisfactory. They indicated lack of experience on the part of the camera men and monitor operators, as well as deficiencies in the equipment. Notable is the limitation imposed by the use of a single camera for picking up outdoor scenes.

The initial transmission of motion picture film was, in general, highly satisfactory, the criticisms being directed to the material rather than the clarity of reception. Because sharpness and definition are expected by the audience, it may be expected that soft shots and fadeouts will not be used in films made for telecasting, since they are considered by the uninitiated to be evidence of faulty transmission or reception.

Live talent studio programs are not yet satisfactory. Some of the faults appear to be due to unskillful monitoring. Dark patches are seen in the pictures from time to time, particularly when the pick-up is shifted from one camera to another. There is evidence of inexperience and inadequate facilities in the lighting of studio programs.

These comments on the initial telecasts are made to serve as a basis of comparison with future programs.

Receivers Superior to Transmitter: It is unfortunate, though understandable, that the public, watching the first programs, puts all the blame for defective images on the receiving sets. The remarkable clarity during the better parts of the transmission shows definitely that the receivers are much in advance of the transmitting equipment in their certainty of operation. Far from being in immediate need of further improvement, certain of the receivers now on sale will do full justice to far more perfect telecasting than is available at this time.

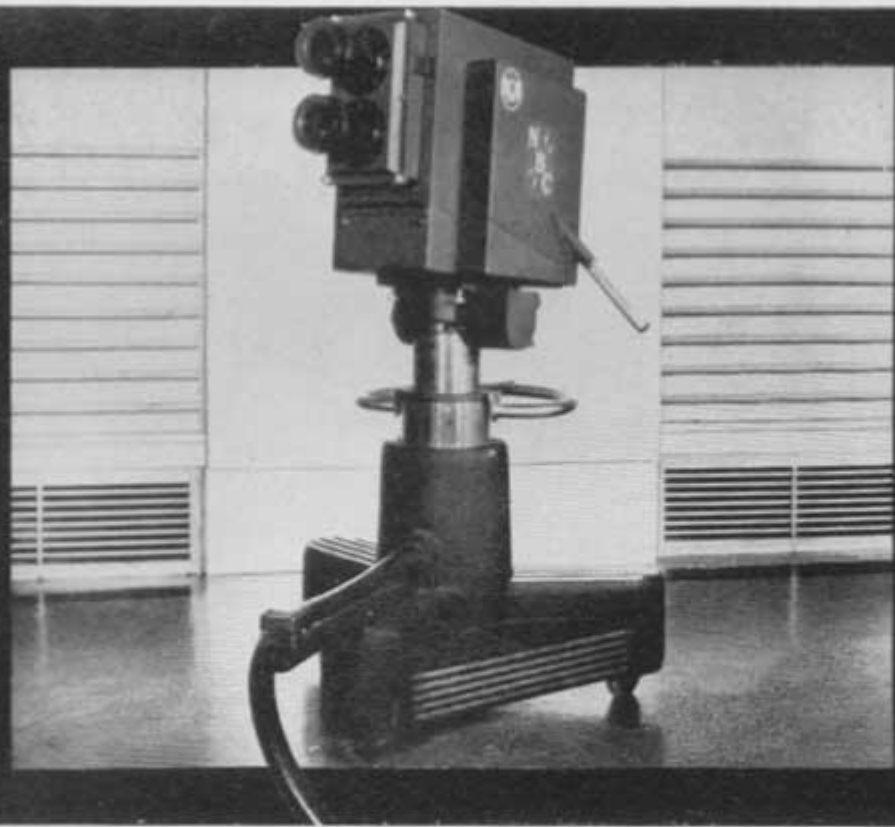

FIG. 26. TELEVISION CAMERA, 1939 MODEL. THIS IS ONE OF THE CAMERAS USED IN THE NBC STUDIOS AT NEW YORK CITY.

CHAPTER TWO

Workings of a Modern Television Transmitting Station

In the preceding chapter, we have reviewed the functioning of television equipment without touching on the technical aspects. Now, let us look a little more closely into the transmitting apparatus and its operation.

The Camera Tube: Figs. 26, 27, and 28 show the details of the television camera and the camera tube, while Fig. 31 gives the circuit of the associated equipment. While there are variations of the camera tube illustrated here, this type is described because it is in actual use in the NBC studios.

The camera, Fig. 26, contains a viewing lens for the use of the operator and, below, a lens for focusing the view on the photoelectric mosaic plate in the camera tube. This plate is shown in Fig. 28. Since the

complete view is focused on the entire area of the sensitive plate, it is obvious that the whole area cannot register the various degrees of light at one time.

Therefore, the plate is scanned by a cathode ray beam, line by line, until the entire area is covered, and only the photoelectric response within the pin-point area of the cathode ray beam is passed on to the video pre-amplifier. The pre-amplifier, of wide-band design, has a practically flat response up to 8 mc. It is mounted in the television camera, and is used to step the video signals up to a level sufficient for transmission to the monitoring booth.

The horizontal and vertical scanning movements of the cathode ray beam are controlled by the deflection voltage generator which, in

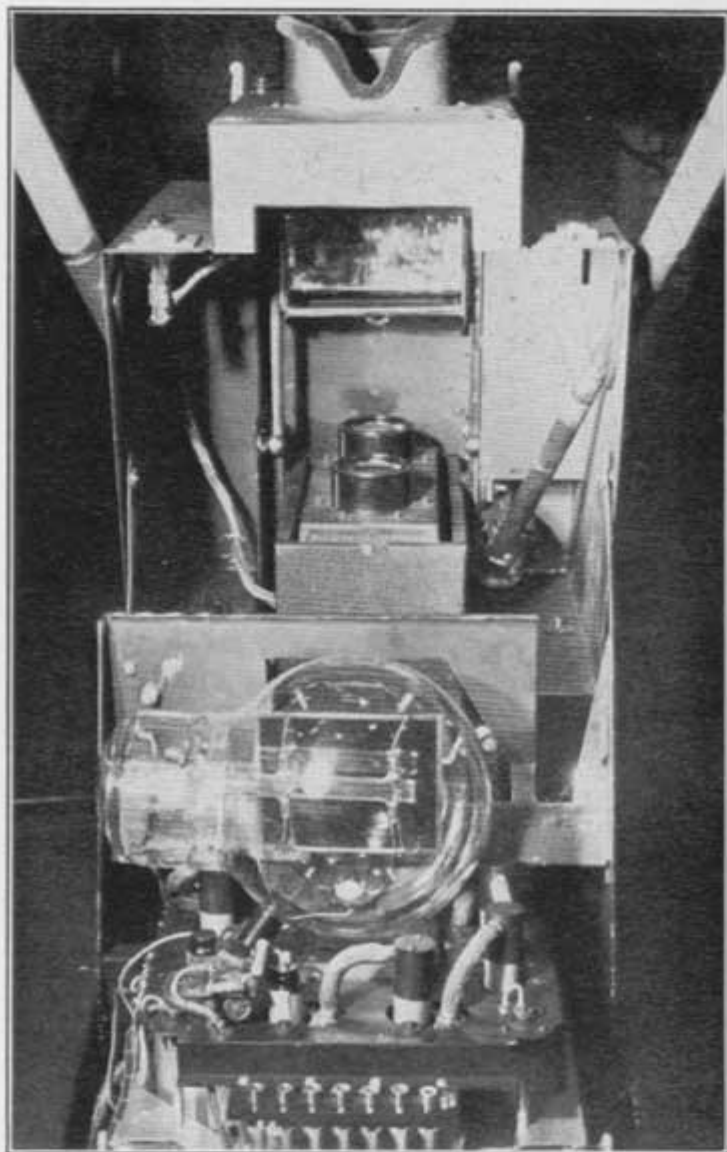

FIG. 27. A TELEVISION CAMERA IS STRIKINGLY DIFFERENT FROM A MOVIE CAMERA IN THAT IT HAS NO MOVING MECHANISM. THIS VIEW IS FROM THE REAR OF THE CAMERA WITH THE TOP, CARRYING THE LENSES, RAISED.

turn, is timed by the synchronizing impulse generator. This also times the blanking voltage generator, which extinguishes the beam during the return trace after the end of each horizontal scanning line, and after the completion of each frame.

Monitoring Controls: From the pre-amplifier in the television camera, the signal travels by coaxial cable to the corresponding monitoring position at the control room. There must be a monitoring position for each of the two or more cameras used in the

studio, since each one is kept in readiness at all times so that transmission can be shifted from close-up to far shots, in accordance with the plan of the program. Obviously, if several cameras were shifted to a single monitoring position, there would be a delay for readjustments on the part of the operator.

Each monitoring operator can see the studio and can hear the sound part of the program from a loudspeaker. At the same time, he must watch his video monitoring

tube, which shows the image being received from his camera. Thus he knows the quality of the image, and the defects that require correction. In addition, he has an oscilloscope monitor, showing the relative amplitude of the video signal and synchronizing impulses, to indicate the exact character of the television signal. Views of this equipment at the studio will be seen in Fig. 32, and in the mobile unit, Fig. 41.

the operator, by which he can correct certain of the signal defects which may occur. Secondary emission in the camera may result in an appearance of uneven illumination in the received image. This, we say, is improper or uneven shading, for shadows are formed on certain parts of the picture. Neutralizing voltages, generated separately and applied synchronously through the controls of the shading panel, permit the correc-

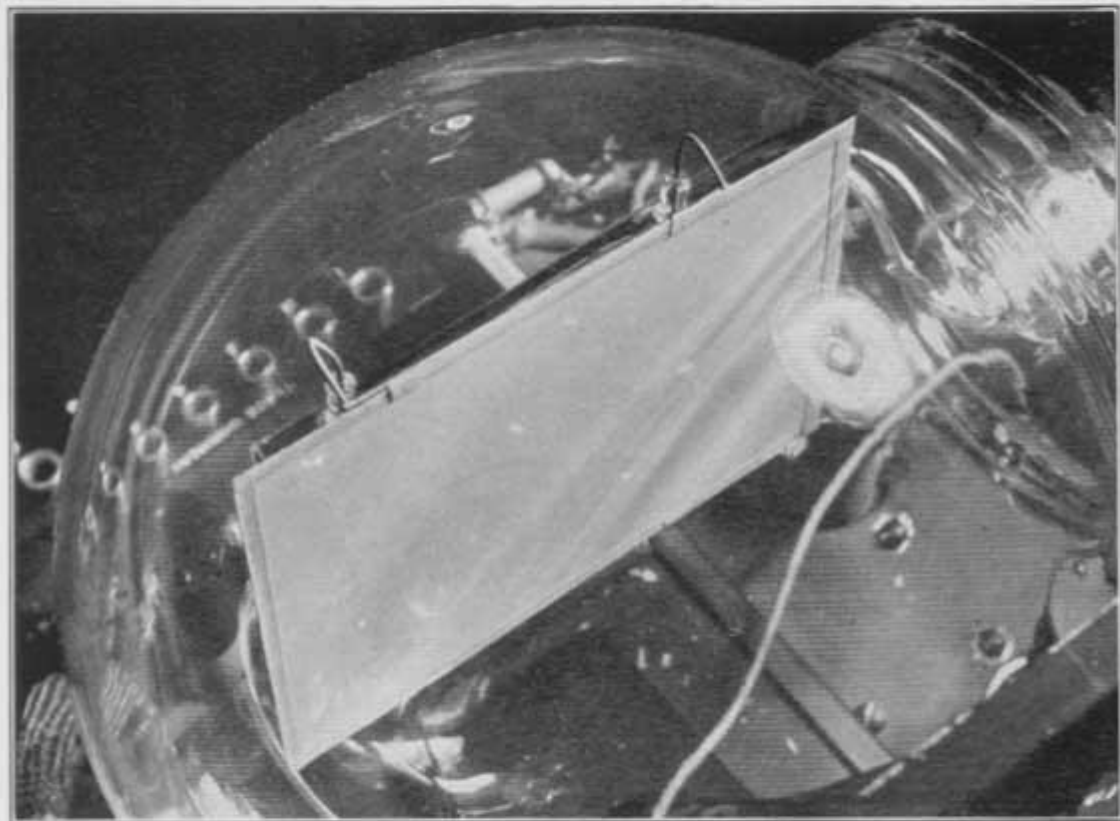

FIG. 28. THIS IS THE CAMERA TUBE, SHOWING THE PLATE, COVERED WITH A MYRIAD OF MINUTE LIGHT SENSITIVE PHOTO-ELECTRIC CELLS, ON WHICH THE LENS FOCUSES THE SCENE VIEWED BY THE CAMERA. THIS PLATE IS SCANNED, LINE BY LINE, BY A CATHODE RAY BEAM.

Since each camera operator must keep his eyes on the scene being televised, manual signals cannot be used to convey instructions to him from the control room. That is why each monitoring operator wears a breast microphone connected to head phones worn by his cameraman and the assistants. Constant communication is required, since the cameraman has no way of knowing how his shots register on the monitoring picture tube.

There is a great array of controls before

tion of such defects in the signals from the camera tube.

In addition, the monitoring operator can regulate the overall brightness of the transmitted image, and the contrast between the light and dark parts.

Receiver Corrections: There is always a temptation, when watching a television program, to change the receiver controls if the image becomes faulty. However, as you will understand from the foregoing, the moni-



FIG. 29. ABOVE, A LONG-RANGE SHOT, AS SEEN IN THE PICTURE TUBE OF A TELEVISION RECEIVER. FROM THIS, YOU CAN REALIZE THAT THE TELEVISION CAMERA IS NO LONGER LIMITED TO CLOSE-UP VIEWING.

FIG. 30. BELOW, NBC ENGINEER JOHN KNIGHT AT THE TELEVISION CONTROL CONSOLE, WHERE STATION W2XBS IS STOPPED, STARTED, AND MONITORED FOR BOTH SIGHT AND SOUND.

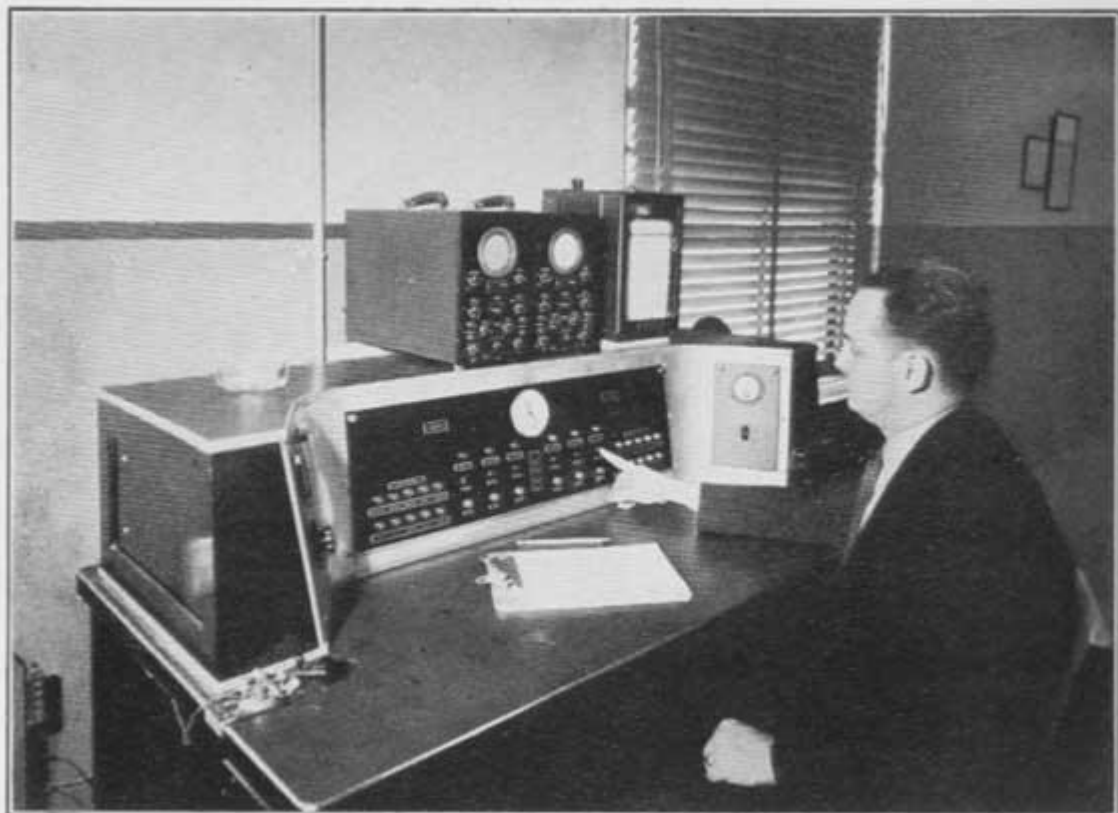

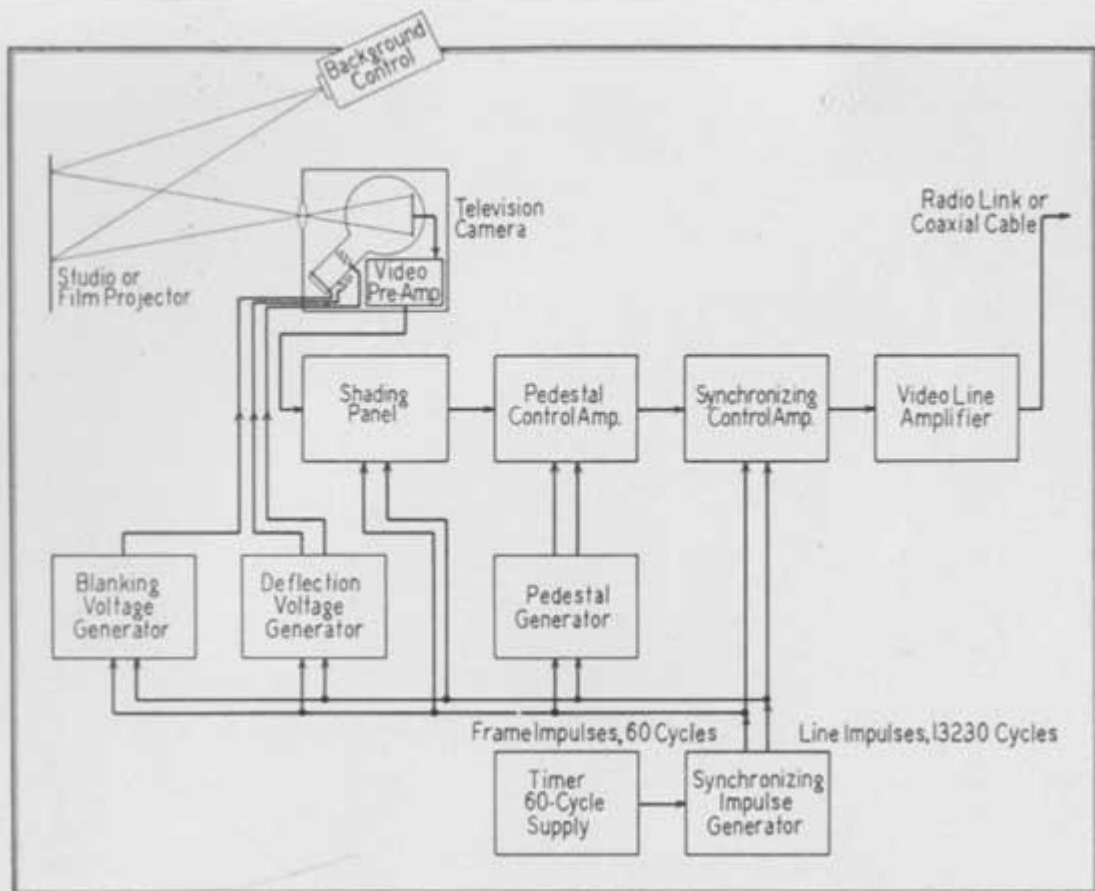

FIG. 31. BLOCK DIAGRAM OF THE VARIOUS ELEMENTS OF A TELEVISION TRANSMITTER. THE MODERN METHOD OF TRANSMISSION LOCALIZES THE COMPLEX, ULTRA-PRECISION EQUIPMENT AND CIRCUITS AT THE TRANSMITTER, THUS SIMPLIFYING THE RECEIVING SETS.

toring operators are aware of the same defects that you see and, as quickly as possible, within the limits of their controls, they restore the transmitted picture to normal values. For that reason, you should not try to make corrections at the receiver, once you have set the adjustments, for when the correction has been applied at the control room, your receiver will be out of adjustment again!

Pedestal Control Amplifier: As shown in Fig. 31, the corrected video signal goes to a control amplifier, where the level of the pedestal voltage is set. On page 22, Chapter 1 it was explained that within 80% of the amplitude of the transmitted signal there is the picture range from white to black. The pedestal voltage supplied by the pedestal generator is slightly higher than the voltage required to produce black in the picture.

Sync Control Amplifier: Beyond the

pedestal voltage, in the blacker-than-black 20% of the signal amplitude, are added the synchronizing impulses which blank out the return trace of the cathode ray beam in the receiving picture tube at the end of each line, and at the completion of each interlace, or half-frame, when the frame synchronizing impulses are transmitted.

You will notice the return trace lines on the receiving picture tube when no signals are being received. Sometimes, during test transmissions, or when an insufficient signal is being picked up by the antenna, retraced lines appear, slanting down from right to left. In the former case, the complete signal is not being put out. In the latter case, adequate blanking signal is not being received.

As you will see in Fig. 31, the synchronizing control amplifier is under the control of the synchronizing impulse generator.



FIG. 32. MONITORING BOOTH, OVERLOOKING THE NBC TELEVISION STUDIO. THE OPERATOR, LOOKING THROUGH A GLASS PANEL, WATCHES THE ACTION, AND CHECKS THE PICK-UP IN THE PICTURE TUBE. DETAILS OF THE EQUIPMENT ARE GIVEN IN OTHER ILLUSTRATIONS.

The word "synchronizing" has attained such common use in television, because the operation of the whole system is tied to synchronous control, that this word is generally abbreviated to "sync."

Video Line Amplifier: Finally, the original video impulse, corrected and monitored at the shading panel, with the pedestal voltage set, and the blanking and synchronizing impulses inserted, is passed into the video line amplifier. This wide-band amplifier merely steps up the signals before they are carried by coaxial cable either directly to the main transmitter or else to a radio link comprising a low-power fixed or portable transmitter and a receiver connected through amplifiers to the main transmitter.

Video Transmitter: The video transmitter sends out only the picture impulses. As stated in the preceding Chapter, much fur-

ther development can be expected in high-power, high-efficiency video transmitters. This is tied in, of course, with research on transmitting antennas. At this time of writing, data on the CBS antenna system on the Chrysler Building is not available. However, much will be learned by comparisons between that installation and the very different NBC antenna on the Empire State Building. Comparative data will be presented in subsequent editions of "LOOK AND LISTEN."

Sound Transmitter: An entirely separate transmitter and antenna provide the sound impulses, inasmuch as a separate carrier frequency is employed. The question is sometimes asked: "Why isn't the sound transmitted on some lower frequency that can be picked up by ordinary all-wave receivers now in use?" It would appear that

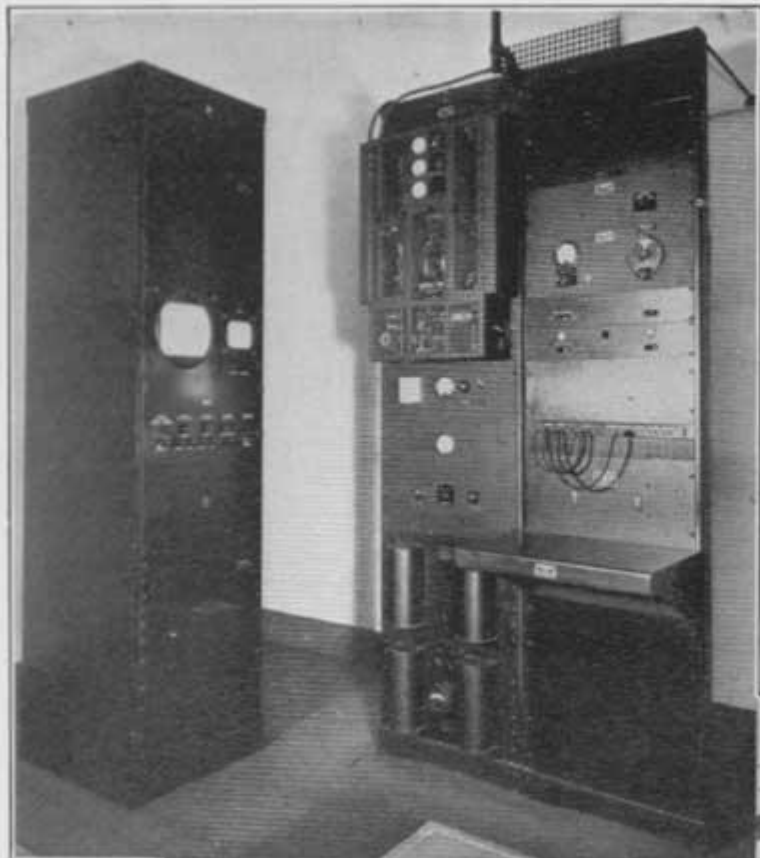

FIG. 33. ABOVE, INTER-BUILDING RELAY TRANSMITTER, OPERATING ON 177 MC., USED AS THE RADIO LINK BETWEEN THE NBC STUDIOS AND STATION W2XB5, ON THE EMPIRE STATE BUILDING, A DISTANCE OF .9 MILE. AT THE LEFT IS THE MONITOR, FOR CHECKING THE PICTURE.

FIG. 34. BELOW, CONTROL PANEL AT W2XB5. THIS EQUIPMENT INCLUDES THE RADIO LINK RECEIVER, AND TERMINAL EQUIPMENT FOR THE COAXIAL CABLE WHICH ALSO CONNECTS THE STUDIOS TO THE TRANSMITTER. NOTE ALSO THE PICTURE MONITOR, PROVIDED AT EVERY CONTROL POINT.



this would simplify the design of the television receiver, by eliminating the special ultra-frequency sound circuits.

Experience has shown that it is prefer-

able, in actual operation, to use adjacent channels for video and audio signals so that the propagation characteristics of the two waves will be similar. The use of widely

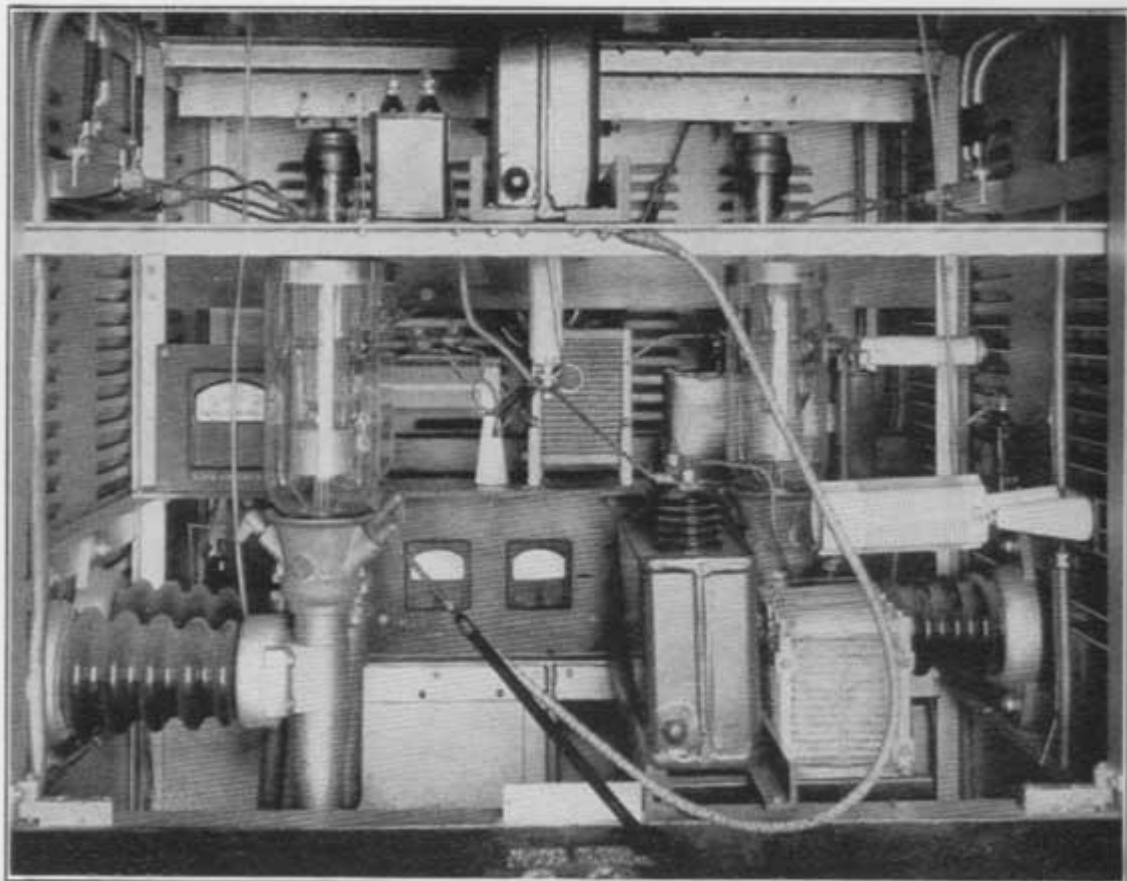

FIG. 35. ONE OF THE TRANSMITTER UNITS AT THE NBC STATION W2XBS. ULTRA FREQUENCIES REQUIRE SPECIAL DESIGN TECHNIQUE. INSULATION BECOMES A PROBLEM, SINCE ORDINARY MATERIALS BREAK DOWN WHEN ULTRA FREQUENCIES, EVEN AT RELATIVELY LOW VOLTAGES, ARE APPLIED TO THEM.

separated channels would introduce more difficulties than would be eliminated.

Rebroadcasting: It is already certain that the portable television transmitter is a vitally important and highly effective adjunct to this new art. Even though the first NBC unit, illustrated in Figs. 38, 39, 40, and 41, represents an expenditure of over \$150,000, its use has chiefly indicated its present limitations, and the direction which further research and revision must take.

The complete equipment is contained in two vans, one housing the 170 mc. transmitter, by means of which the video signals are sent to the Empire State Building for rebroadcasting on the 44-50 mc. channel, and the second carries the video and audio amplifiers and monitoring equipment. Connection to the station for the sound is made by wire, in order to simplify the transmitting apparatus.

When this unit was first put into operation, only one video monitoring position was installed. Experience during the inaugural program at the World's Fair showed that one camera was not enough. English television engineers, present at that time, made the comment that, both from the point of view of entertainment value and assuring continuity in case of equipment failures, two or more cameras are needed.

Commenting on his experiences in picking up the Princeton-Columbia baseball game at Baker Field, New York, on May 17th, 1939, R. W. Pickard, chief cameraman for NBC said that, successful as this program proved to be, a second camera was really needed. With two cameras, it would have been possible to cut in with close up shots, since the lense could be changed on the second camera as conditions required. This is not possible when a single camera is used,



FIG. 36. ABOVE, WATER COOLING EQUIPMENT FOR THE ULTRA-FREQUENCY TRANSMITTING TUBES. THE ROUND TANK IS FOR STORAGE, WHILE THE RECTANGULAR TANK IN THE FOREGROUND CONTAINS THE COOLING UNIT.

FIG. 37. BELOW, TRANSMITTER UNITS FOR VIDEO AND AUDIO FREQUENCIES, AT NBC STATION W2XBS, NEW YORK CITY. THIS VIEW INDICATES THE ELABORATE EQUIPMENT REQUIRED FOR A 1939 TYPE OF TELEVISION STATION.



because the image would be off the air while the lense is being changed.

However, it is reasonable to expect that these shortcomings will be corrected, along with others, and very quickly too, so that, a

year from now, many of the comments in this volume will be reminders of television as it was away back in the beginning.

Transmission of Films: Fig. 23 illustrates the R.C.A. film scanning equipment. This

is a most important adjunct of the television studio, since films provide the least expensive type of program, but are easiest to transmit clearly and distinctly, with a minimum amount of monitoring.

The early film transmission has been criticised severely and rightly so, because the material used has been, for the most part, most unsuited to satisfactory reception.

a maximum of light and dark contrast. Because the lines of the picture are horizontal, they tend to break up horizontal details into confusing patterns. To illustrate this with an extreme case: Venetian blinds might not be recognizable as such, while the pickets of a fence would show up clearly.

Such matters of technique will be studied with the greatest thoroughness by advertis-



FIG. 38. INTERIOR OF THE PICK-UP UNIT OF THE MOBILE EQUIPMENT. THIS CONTAINS THE VIDEO AMPLIFIER AND MONITORING CONTROLS.

Films for televising cannot be picked at random from news shots and industrial continuities. They must be planned and photographed with special reference to the requirements of the receiver, by men who understand thoroughly the electrical and mechanical limitations of image reception, and the physiological and psychological reaction of the audience.

It is of the utmost importance that subjects be simple in their details, and provide

ing agencies when their clients begin to use television—as they are ready to do as soon as an audience is available, and permission is granted by the FCC to transmit commercial programs.

Films are much cheaper than live-talent programs. The former can be produced under more favorable conditions, and require less rehearsing, since they can be retaken and cut, while the latter must proceed without interruption. Furthermore, motion

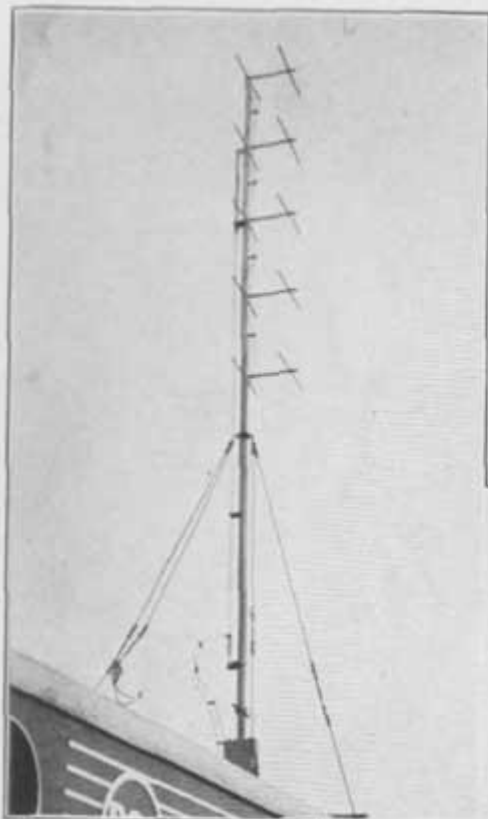

FIG. 39. THE "TROLLEY" ANTENNA, RUN UPON THE TRANSMITTER UNIT OF NBC'S MOBILE TELEVISION EQUIPMENT. THE KING AND QUEEN OF ENGLAND WERE TELEVISED BY MEANS OF THIS PORTABLE STATION WHICH IS PICKED UP BY W2XB5, FOR REBROADCASTING TO THE NEW YORK AREA. CONSIDERABLE IMPROVEMENT IN PICTURE QUALITY HAS BEEN NOTED SINCE THIS TRANSMITTER WAS FIRST PUT INTO OPERATION.

FIG. 40. A PLATFORM ON THE TOP OF THE PICK-UP UNIT OFFERS A POINT OF VANTAGE FOR THE CAMERA AND MICROPHONE. THE MONITORING OPERATOR CAN BE SEEN AT THE CONTROLS IN THE VAN. SPACE IS PROVIDED ON THE LEFT FOR THE CAMERA AND THE REELS OF COAXIAL CABLE REQUIRED FOR CONNECTIONS WHICH RUN OUT FROM THE TERMINALS BELOW THE DOORS.



picture camera equipment is highly adaptable and versatile. And last, but not least, filmed programs will be in great demand when there are a number of television transmitters in operation because of the speed

and low cost of transmitting duplicate prints.

The R.C.A. television film-scanning equipment employs the conventional intermittent-motion feed. Farnsworth, however, scans a film in continuous movement. It is under-

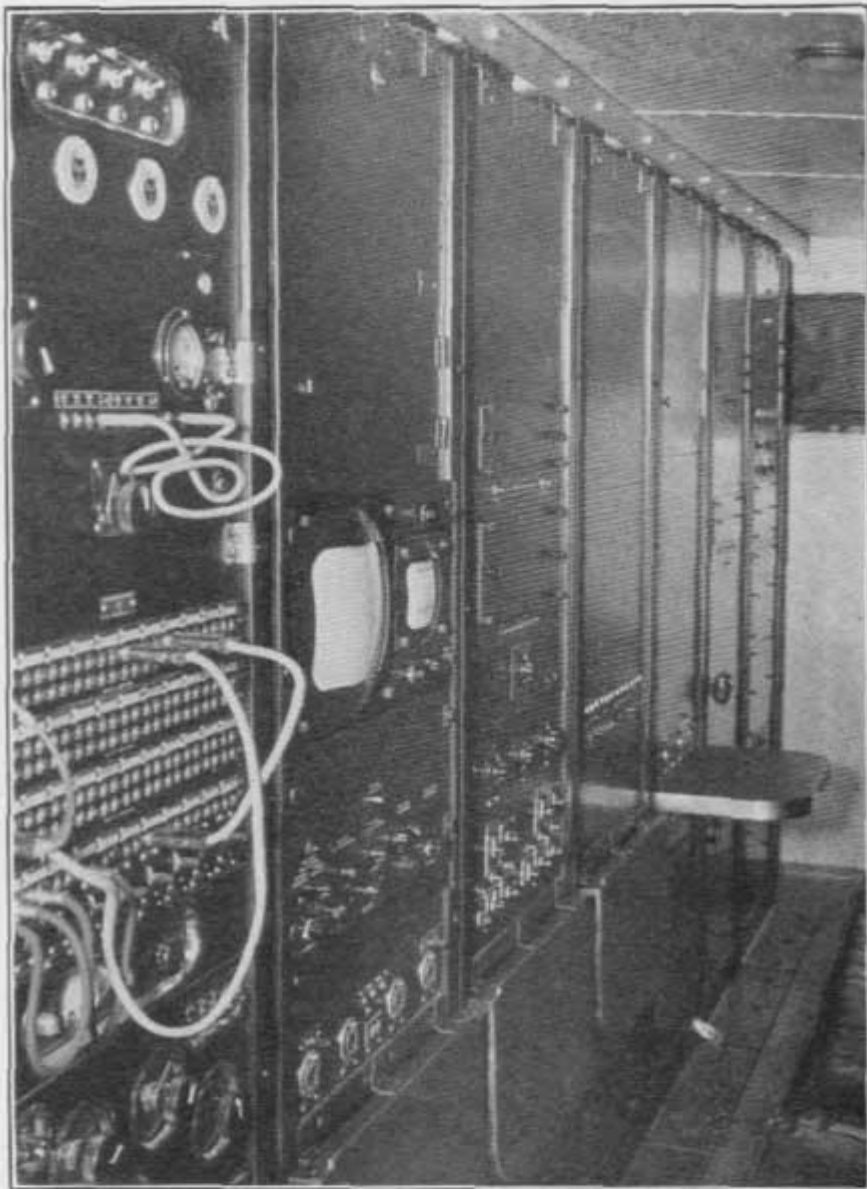

FIG. 41. CLOSE-UP OF THE MONITORING EQUIPMENT IN THE MOBILE PICK-UP UNIT. PROVISION IS MADE FOR A SECOND POSITION.

stood that the CBS transmitter on the Chrysler Building will have both types of machines. In that case, we shall have an opportunity to check their relative performance. It is reasonable to expect continuous improvement in transmitting equipment as new devices and methods demonstrate their

superiority over those now in use. In fact, the rate of obsolescence will be much higher for transmitters than receivers, since improvements can be made at the transmitting end without making the receiving sets obsolete and without requiring any modification of the present R.M.A. transmitting standards.

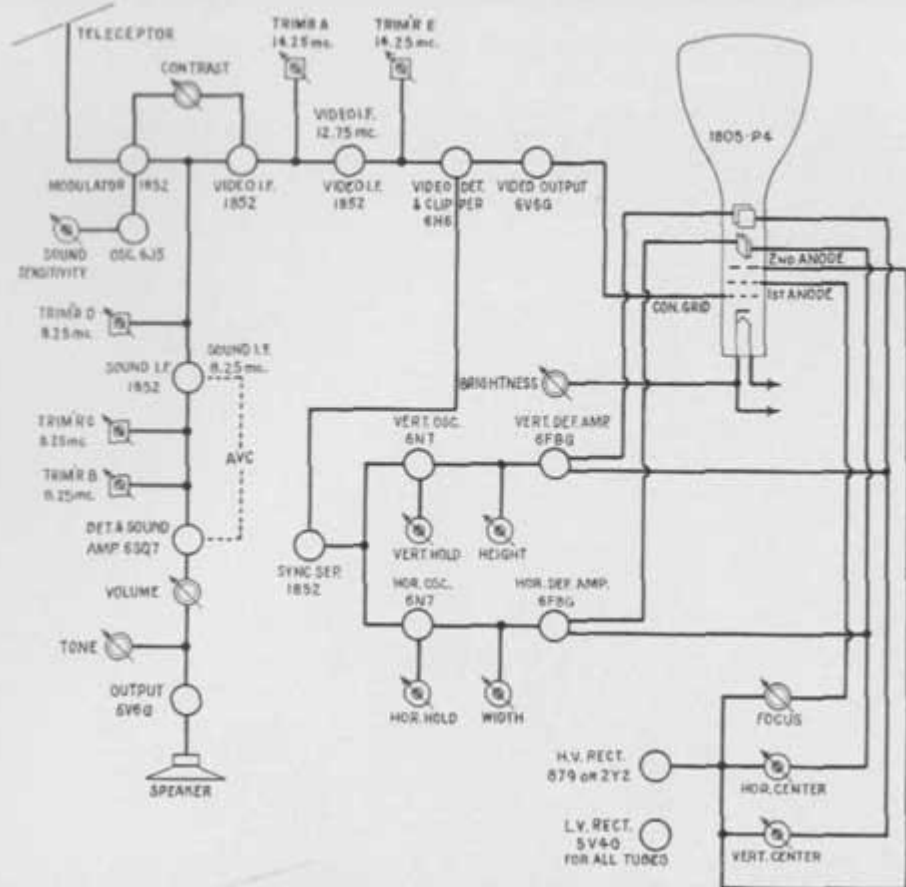

FIG. 42. BLOCK DIAGRAM OF THE ANDREA I-F-5 AND KT-E-5 MODELS, SHOWING ELEMENTS OF A TELEVISION RECEIVER.

CHAPTER THREE

Functions of a Modern Television Sight and Sound Receiver

Several television courses have been given by manufacturers for the benefit of servicemen, to instruct them in the functions of receiving circuits. The amount of practical benefit that has been derived from such courses, unfortunately, has been surprisingly small.

That is probably because the instructors thought in terms of the mathematics of circuit design, all of which mean nothing to the serviceman or set-builder whose problem is not to design circuits, but to get satisfactory

performance from a given receiver. Then it is necessary, of course, to understand the intended functions of the circuits in order to localize failures. Mathematics will not give you a bird's-eye view of the things that take place between the antenna and the picture tube and loudspeaker, and that is what you need most of all to work intelligently with television receivers.

Such a purely practical approach will leave some of your questions unanswered, but unless this Chapter is confined strictly to

the simplest considerations, it would be necessary to explain one explanation with another, ad infinitum! If you are interested in delving into the wide ramifications of television engineering, your requirements will be met more readily by such courses as are offered in the colleges or television training schools, rather than by the contents of a single book.

Fundamental Circuit: For purpose of discussion, let us consider the circuit of the Andrea I-F-5 sight-and-sound receiver,² since this is a commercial design of established performance. While there are variations in the circuit details of different makes and models, the essential elements are identical.

The simplified diagram, Fig. 42, shows the tube types and their successive functions, and the locations of the various controls. You will see that this receiver has separate I.F. amplifying circuits for the video and audio frequencies. The former terminate in the picture tube controls, and the latter in the loudspeaker. Since the video and audio signals are transmitted on separate carrier frequencies, a single oscillator produces the two I.F. frequencies.

Thus, you see, this one set receives signals from two transmitters, simultaneously, through one antenna. The two signals, modulated by one oscillator, pass through separate I.F. amplifiers, so that they can perform their individual functions of forming pictures and making sound.

I.F. Frequencies: Conventional I.F. frequencies of broadcast receivers are not suited to the reception of ultra-frequency transmission. This receiver operates on the following frequencies when tuned to the first and second television channels:

CHANNEL 1

Video Carrier, 45.25 mc.	} Oscillator, 58 mc.	Video I.F., 12.75 mc.
Audio Carrier, 49.75 mc.		Sound I.F., 8.25 mc.

CHANNEL 2

Video Carrier, 51.25 mc.	} Oscillator, 64 mc.	Video I.F., 12.75 mc.
Audio Carrier, 55.75 mc.		Sound I.F., 8.25 mc.

Individual, switch-controlled tuning circuits are employed for the different channels because, from both the electrical and practical standpoints, tuning with a variable gang condenser is not satisfactory.

The video I.F. circuits differ greatly from broadcast receiver types, because they are designed to pass a band $3\frac{1}{2}$ mc. wide, down only 10% at the ends and at the center of the band. The transformers are not adjustable, since they are matched in production to give a predetermined curve on a cathode ray oscillograph.

Audio Circuits: The audio circuits are of conventional design, with which every serviceman and set builder is familiar. An 1852 I.F. amplifier is followed by a 6SQ7 second detector and first audio amplifier, feeding a 6V6G output tube.

Video Detector and Clipper: At the 6H6 tube, which serves as the video second detector, the 20% of the amplitude of the received signal, which carries the synchronizing impulses, is separated from the 80% which provides the picture impulses. The entire video signal is fed to the 6V6G video output tube. Then, from the clipper circuit, the synchronizing impulses are passed on to the 1852 sync separate tube.

Video Output: The detected video signal from the 6H6 is amplified by a 6V6G, and is applied to the picture tube. This modulates the electron stream directed on the fluorescent screen, thus varying the brightness of the spot.

Sync Separator: The synchronizing impulses fed from the 6H6 clipper circuits control not only the timing of the horizontal scanning but the spacing between the lines and the framing. These impulses are amplified in the sync separator, and go to the separate vertical and horizontal oscillators and which in turn feed the deflection amplifier tubes.

² This is the same circuit that is used for the Andrea KT-E-5 construction kit, described in Chapter IV, and is shown completely in the large sheets which accompany this volume.

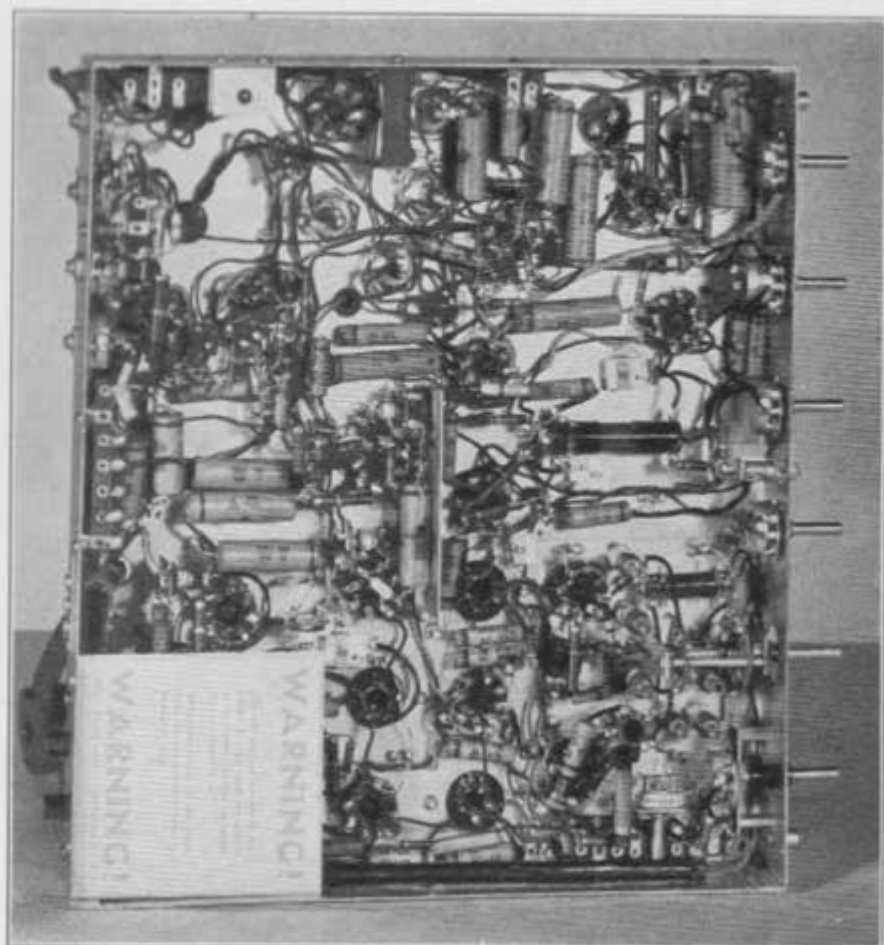

FIG. 43. UNDER SIDE OF THE ANDREA RECEIVER. A SAFETY SWITCH CUTS OFF THE CURRENT WHEN THE BASE PLATE IS REMOVED. EXTRA PROTECTION IS PROVIDED BY AN INNER STEEL SAFETY PLATE.

Horizontal Oscillator and Amplifier:

The horizontal oscillator, triggered off by the horizontal synchronizing impulses, applies a voltage to the horizontal deflection amplifier which, in turn, is connected to the horizontal deflection plates of the picture tube. The purpose of this circuit is to move the cathode ray beam across the screen for one line, and back again to start the next line.

Vertical Oscillator and Amplifier:

The vertical oscillator, under control of the vertical synchronizing impulses, applies a voltage to the vertical deflection amplifier which, in turn, is connected to the vertical deflection plates of the picture tube. The purpose of this circuit is to space the succeeding lines, formed by the beam as it sweeps across the screen, to make up the picture frames. Otherwise, there would be no picture, for one line would be traced upon the preceding

line. Furthermore, the vertical oscillator controls the starting of each interlaced frame, so that the top of the picture will be seen at the top of the picture tube screen, and not at some point below.

Contrast Control: The contrast control regulates the response of the receiver to the incoming signals. It is actually a sensitivity control. Thus, changing the contrast control affects both the picture and the sound.

Brightness Control: The brightness control is a variable bias for the control grid of the picture tube, regulating the overall average current in the cathode ray beam which is directed at the fluorescent screen. The current in this beam is approximately .1 milliamperes at 2,500 volts.

Picture Width and Hold Controls: The frequency of the horizontal deflection oscillator is adjusted by the horizontal hold con-

trol, and extent of the horizontal sweep or line scanning is regulated by the picture width control. By mis-adjusting the horizontal hold control, it is possible to make two narrow images appear side by side. The width and horizontal hold controls affect each other slightly, so that if one is changed, the other may require resetting.

or sensitivity control. Thus, while a change in the contrast control affects the audio volume, an adjustment of the volume does not alter the picture. Although a tone control is provided, you will find the true high-fidelity response of television so delightful and so entirely free from background noise that you will hardly want to use the tone

FIG. 44. THE AUTHOR POINTS TO THE INNER SAFETY PLATE WHICH COVERS THE HIGH VOLTAGE CONNECTIONS. THIS IS DOUBLE PROTECTION, SINCE THE SAFETY SWITCH CUTS OFF THE CURRENT WHEN THE BASE PLATE, COVERING THE BOTTOM OF THE CHASSIS, IS LOOSENED. THUS, IT IS IMPOSSIBLE TO COME IN CONTACT WITH ANY HIGH-VOLTAGE PARTS WHILE THE CURRENT IS TURNED ON.

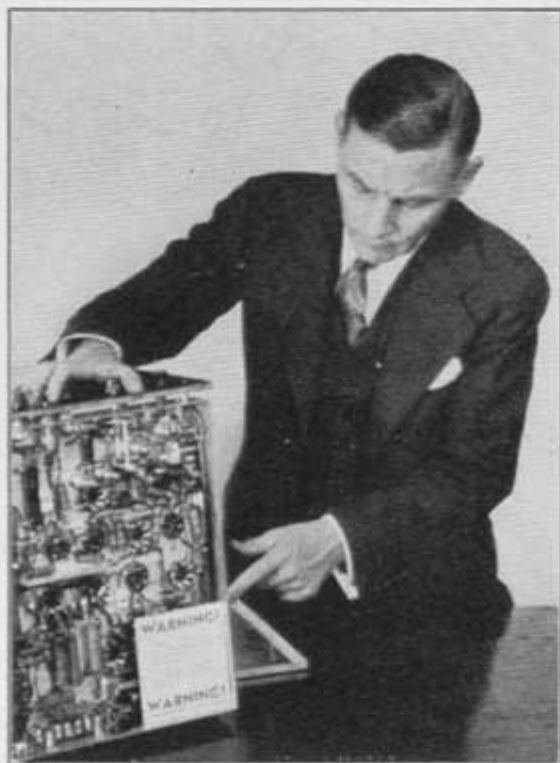

ALL SERVICE WORK ON THIS RECEIVER CAN BE DONE WITHOUT RUNNING ANY RISK OF INJURY. TESTS ON THE PARTS UNDER THE CHASSIS DO NOT REQUIRE CURRENT WHILE THEY ARE BEING MADE. ALL PARTS CARRYING 2,500 VOLTS ARE GIVEN A BREAK-DOWN TEST AT THE FACTORY ON 6,000 VOLTS, TO CHECK THE STRENGTH OF THE INSULATION. ACTUALLY, THERE IS LESS DANGER FROM THIS TELEVISION RECEIVER THAN FROM MANY COMMON HOUSEHOLD APPLIANCES.

Picture Height and Hold Controls: The operation of the picture height and vertical hold controls perform functions in the vertical deflection oscillator circuits similar to the width and horizontal hold controls just described. When the hold control is set at twice the operating frequency, two pictures appear, one above the other. Since the picture height and vertical hold controls are interrelated, they should be adjusted together.

Centering Controls: The vertical and horizontal centering controls are actually variable biases on the vertical and horizontal deflecting plate, as you will see from Fig. 42.

Sound Volume and Tone: Audio volume is controlled independently of the contrast,

control to cut down the upper register response.

Rectifier Tubes: A 5V4G tube supplies the plate and bias voltages to the receiving tubes. This rectifier circuit is similar to those in broadcast receivers. The 2,500-volt supply for the picture tube comes from a 2Y2 or 879 rectifier. This is the tube with the heavily insulated cap. Fig. 42 shows the application of the high voltage to the elements of the picture tube, and the use of the focus and centering controls in adjusting the voltages.

Picture Tube: The cathode ray beam in the picture tube can be deflected by voltages applied to deflection plates within the tube (electrostatic deflection), or by current flow-

ing through coils placed outside the tube (magnetic deflection). Standard practice is to use electrostatic deflection for 5-in. picture tubes, and electromagnetic deflection for the 9-in. and 12-in. tubes. The Andrea receiver under consideration has an 1805-P4 short-neck 5-in. picture tube. This tube was developed by the National Union Company in conjunction with Andrea engineers in order to reduce the depth of the cabinet when the tube is mounted horizontally. This tube is about 4 ins. shorter than the ordinary long-neck tube.

It is not possible to use a 9-in. or 12-in. tube in a receiver designed for a 5-in. tube. First, changing to the larger tube would require means for magnetic deflection. Second, the larger tube would require additional power for the vertical and horizontal deflection circuits, and an increase in the voltage to about 7,000.

Screen Colors: Black-and-white screen color is rated by the picture tube manufacturers as the color most acceptable to the eyes. This, of course, was determined long ago by motion picture photography. When any outside source of light is falling on the screen of a black and white tube, it appears to have a bluish tinge. That disappears, however, when the light is cut off.

Second in eye acceptability is the black-and-yellowish color. However, it has been determined that novelty color effects in television, as in motion pictures, are soon tiring to the eyes.

Green-and-white screens rank a poor third for television. They are used in oscillo-

graphs, however, because of the long life of the materials used for the green-and-white screens.

High Voltage Hazard: The question is asked frequently: "What hazards are present in a television receiver, due to high voltages?" This is a natural question, since television sets use 2,500 to 7,000 volts, compared to 250 to 750 volts in ordinary broadcast receivers.

Fortunately, it is possible to give a reassuring answer. No one is ever endangered by the voltages used in broadcast receivers. Yet, if you go prying into them you can manage to get a serious, or even fatal, shock. But you just naturally wouldn't do it.

As far as that goes, you can injure yourself just as seriously, and more easily, by getting hold of the terminals of the cord you use for your toaster or coffee percolator. Perhaps the simplest way to electrocute yourself, if you are determined to do so, is to stand in the bath tub and play with the electric light fixture.

Manufacturers of television receivers have provided automatic safety switches and special cover plates which make it impossible for you to come in contact with parts carrying the high voltages. The moment you open the set, before you can get at the cover plates to remove them, automatic switches cut off the current. These protective devices, which you do not have on ordinary broadcast receivers or household appliances, make television sets actually safer to handle than the appliances you use every day in your home.

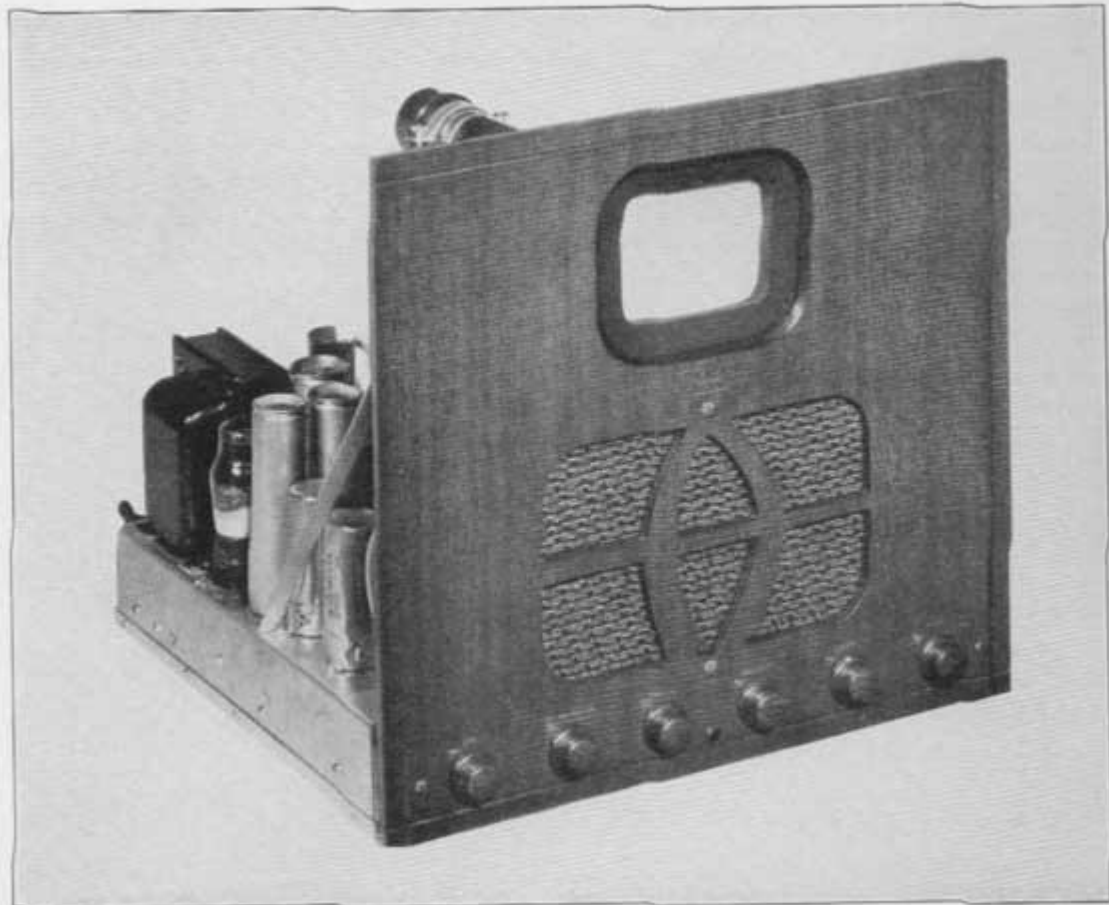

FIG. 45. FRONT VIEW OF THE ASSEMBLED ANDREA TELEVISION KIT. THE FRONT PANEL CAN BE REMOVED IF THE SET IS TO BE INSTALLED IN A CONSOLE OR TABLE CABINET.

CHAPTER FOUR

Detailed instructions for assembling the Andrea KT-E-5 Television Sight and Sound Receiver

There are so many things about the design, construction and functioning of television receivers which are so completely different from all-wave sound receivers that past experience cannot be assumed to apply to building television sets.

In fact, an extensive knowledge of the troubles encountered by television set builders shows conclusively that the majority of mistakes are made because constructors permit themselves to take short cuts, and to be a little bit careless with small details—things that would be perfectly all right in building straight sound sets, but spell the difference between success and failure of television equipment.

New Design Problems: While a broadcast receiver or a power amplifier can be assembled from any collection of parts that have approximately related characteristics, a television receiver capable of delivering clear, sharp images is a highly integrated design in which the parts do not perform their functions independently, but are closely interrelated.

In other words, a television receiver is not a collection of separate circuit units. Instead, the complete receiver is a single circuit unit, and is designed as such.

Moreover, new effects are introduced by the handling of ultra-high frequencies. Shielding cannot be planned in any casual

manner. Stray currents in the shields and chassis cause the most annoying difficulties. The most unexpected and obscure effects come from stray magnetic fields and couplings. Sometimes they can be overcome in the simplest ways. Sometimes it is easiest to discard the whole plan and to make a new start.

Again, what is a resistor in a broadcast set may act merely as a condenser when ultra frequencies are applied to it, while an ordinary condenser may act simply as a resistor! It is true that the design of high-voltage transformers is a well established art, yet the design of high-voltage transformers of small mechanical dimensions, to deliver a fraction of a milliampere at 2,500 up to 7,000 volts is a trade secret among the very few manufacturers who have found out how to build them!

Actually, while a television receiver operates by radio, in its design details it is hardly more related to a broadcast set than the log cabin is related to a modern American home. Thus, the experienced builder of straight sound equipment has as much to learn about television construction as an early settler would have to learn about the use of our present-day building materials. The more you dig into this new art, the more you will realize that the foregoing is literally true.

Wiring Is Part of Design: Experienced servicemen, for example, to whom the most complicated circuit diagram is a simple road-map for the radio and audio currents, have been shocked to find that they don't know how to wire television receivers. That is, they can connect up the parts correctly, but they can't make the sets work! Yet they can take the most complicated all-wave radios apart and put them together with the most amazing skill.

The reason is this: The arrangement of the wires, their locations with reference to the chassis, the length of the leads on the resistors and by-pass condensers, and the positions of certain parts with respect to others have a direct bearing on the final results registered at the picture tube. Thus the plan of the wiring is an important part of the circuits themselves. And that is one of

the reasons why we speak of a television receiver as being a highly integrated design.

Schematic Only for Checking: In planning the original instructions for building the Andrea Model KT-E-5 television kit assembly instructions, the ¹ schematic wiring diagram was omitted deliberately. The engineers of the Andrea Radio Corporation knew that if the schematic was included, expert servicemen and set builders would assemble and wire the set from the schematic, instead of following the picture diagrams literally. Since the inevitable result would be unsatisfactory performance, the temptation to use the schematic was eliminated by supplying only the picture diagrams.

Even so, more trouble has been reported from experienced servicemen and set builders who rushed through the assembly stages with their customary alacrity, than from inexperienced workers who followed the instructions blindly, or the engineers to whom the arrangement of successive steps and stages made a logical appeal.

Building An Andrea KT-E-5: The Andrea KT-E-5 sight and sound receiver kit has been selected for description in this volume for several reasons. First of all, the design of this equipment was developed and perfected as a commercial receiver, and not merely as an experimental kit for set builders. Actually, this is the standard Andrea 1-F-5 "Sharp-Focus" design, which has already achieved an outstanding record of fine performance in New York, Connecticut, New Jersey, Pennsylvania and California. No other kit available at this time has this background of public endorsement nor has any other make of factory-built receiver been offered as a construction kit.

The Andrea KT-E-5 kit is really the standard model 1-F-5 receiver in knock-down form, and when assembled in accordance with the instructions given in this volume, is an exact duplicate, both as to construction and performance, of the commercial type 1-F-5 set. Thus, you are assured of results from the assembled kit which will meet established, accepted standards of performance.

¹A large-size schematic is supplied separately with this book.



FIG. 46. SIDE VIEW OF THE ASSEMBLED SIGHT AND SOUND RECEIVER, WITH THE FIVE-INCH PICTURE TUBE MOUNTED AND READY TO OPERATE.

After all, the construction of a television sight and sound receiver calls for a substantial investment, and it is important to know, before you go to the expense of buying the kit, that the design has passed the experimental stage and has definitely proved its merit under a wide range of operating conditions.

General Specifications of the KT-E-5:

The Andrea KT-E-5 is a 17-tube receiver for television sight and sound. Equipped with a 5-in. black-and-white picture tube, it produces images of such clarity and distinction as to compare favorably with motion pictures of the same size.

It operates on 441 lines, 30 frames per second interlaced. It is designed for use on

110 to 130 volts, 60 cycles AC. The standard kit provides reception on 44 to 50 and 50 to 56 mc. However, other tuning channels can be obtained if they are specified when the kit is purchased. As you will see in Fig. 49, the complete R.F. tuning unit is supplied all assembled on a steel plate, and is not only wired, but is pre-adjusted to the required R.F. frequencies under actual receiving conditions. To change the tuning channels at any time requires only a change of this unit.

In most parts of the U.S., one tuning channel will be sufficient. However, two channels are needed for New York City, and within a few years, there may be two bands in use in some of the other cities. Two

bands will probably be the limit in any one section for a long time to come, and if three or four stations are erected in any city, they will undoubtedly have to share time.

The circuit is described as a "duo lateral" superheterodyne, since a single oscillator tube modulates the video and sound carrier frequencies. The two intermediate frequencies are amplified in separate I.F. circuits, terminating in power amplifiers which control the picture tube and actuate the loudspeaker. Additional circuit data is presented in Chapter 3.

Amazing as it may seem until you have listened with your own ears, the tone quality from the 6½-in. speaker on television sound is far superior to anything you have ever heard from the most expensive receiver operating in the regular broadcast band.

You will see that the 5-in. picture tube is of the short-neck type developed by the National Union Company in conjunction with the Andrea engineers. This tube is nearly 4 ins. shorter than the ordinary long-neck type, permitting a substantial reduction in the depth of the chassis and, correspondingly, in the cabinet. Of the various screen colors available, this black-and-white National Union tube is considered to be more acceptable to the eyes than tubes which have a yellow or greenish tinge.

Description of the KT-E-5 Kit: The Andrea KT-E-5 kit is complete from the front panel right down to the last screw and washer. It includes every item except the tubes. The front panel is cut out and fitted with grill cloth over the speaker opening, and is attractively lacquered and furnished with names on the controls. Holes in the cadmium-plated chassis and base plate are stamped, and the sockets are rivetted in place.

Altogether, there are 206 parts, in addition to the screws, nuts, washers, and similar hardware. Just by way of contrast: The famous 5-tube Neutrodyne construction kit produced by Frank A. D. Andrea in the early days of sound broadcasting had a total of 28 parts. That Neutrodyne kit required 78 soldered joints in the wiring, compared to something over 600 soldered connections

in the wiring of the Andrea KT-E-5 construction kit!

All parts and wiring carrying the high voltage for the picture tube are tested at 6,000 volts, to assure their electrical dependability.

Every part is finished and ready for assembly and wiring, so that no mechanical work is required other than the simple operations which can be carried out with a screwdriver and pliers. No test instruments are needed for aligning the receiver. The R.F. circuits are supplied already wired and tested, so that the final adjustments of the trimmers can be made during the reception of a television program.

Simplified Assembly: The fact that there are many parts to mount and connections to make does not mean, however, that the construction of the Andrea receiver requires skill and experience. This may be your very first attempt at set building, yet you need have no hesitancy about tackling this project, and you can be confident of results equal in every way to those of the famous Andrea factory-built model I-F-5.

Patience and willingness to follow the instructions given in this chapter are the most important elements of success. Don't hurry. Check each step, and recheck your work at the end of each Assembly Stage. If you do that, you will be proud of your receiver, and more than pleased with its performance.

Plan of Assembly: The assembly of the set is divided into six stages. These are illustrated by five diagrams, so that the steps of each stage are shown clearly. Moreover, the parts and wires go on in succeeding layers, starting with those close to the underside of the chassis, exactly as the work is done in a factory assembly line. In fact, one of the reasons why the KT-E-5 is so easy to put together is that this model was designed primarily for factory production.

The Assembly Stages are divided as follows: (1) Wiring the filaments and power transformers. (2) Mounting and wiring the filter condensers and I.F. transformers. (3) Mounting and wiring the controls, trimmers, and R.F. chokes. (4) Wiring the re-



FIG. 47. REAR VIEW OF THE ANDREA RECEIVER. NOTE THE SURPRISING SIMPLICITY OF THE DESIGN. IT CAN BE ASSEMBLED IN LESS THAN TWELVE HOURS BY AN EXPERIENCED SET-BUILDER, BUT A BEGINNER MAY REQUIRE TWENTY-FOUR TO THIRTY HOURS.

sistors. (5) Wiring the by-pass condensers. (6) Mounting the front panel and speaker.

Step-by-Step Instructions: The work is further simplified by step-by-step instructions which serve as a checking list. The steps are arranged in what actual factory assembly experience showed to be the logical order, so that each part or wire is preparation for subsequent parts and wires. You check off each step in the square provided, so that whenever you stop, you can pick up exactly where you left off, with no fear of omitting parts or wires!

Furthermore, and this is of vital importance in the construction of a television receiver, the diagrams show exactly how each lead should be arranged to avoid inter-cir-

cuit couplings and feed-back effects, the elimination of which is one of the greatest problems of television receiver engineering.

Hook-up Wires: Two types of hook-up wire are provided with the Andrea television kit. One is for high-voltage connections, and is of stranded wire with a heavy varnished insulation in various colors. When this wire should be used, it is specified in the step-by-step instructions in this way: (H.V. green wire).

Watch this carefully, for it is important to use the H.V. wire wherever it is called for in the instruction.

The other type, for low-voltage connections, is of solid wire, with a lighter insulation in various colors. When this wire

should be used, it is specified in this way: (black wire). Note that the brown and yellow solid wires are heavier (No. 18 gauge) than the other solid wires which are No. 22 gauge. However, there is one piece of No. 22 brown wire, but that must not be used for connections called for in Assembly Stage No. 1.

Soldered Connections: A generous supply of rosin-core solder is provided with the kit. USE ONLY ROSIN-CORE SOLDER in making connections in this television receiver.

Soldering pastes and liquids, even though they are called "non-corrosive" may do serious harm to the insulation on the various parts. In the wiring of telephone switchboards and instruments, nothing but rosin-core solder is ever permitted. This is just as important in television receiver construction.

A good electric soldering iron is recommended for this work. Don't buy a cheap electric iron. It will prove to be an unsatisfactory investment. Keep your iron clean all the time. If it becomes burned on the end, clean it with a coarse file while it is cold. Then, as soon as it is heated, tin it with rosin-core solder.

Be careful to GUARD AGAINST COLD-SOLDERED JOINTS! See that you apply enough heat to make the solder run freely. Otherwise you may find that the wire is merely stuck in place by the rosin, which is effective INSULATION at the joint.

Do not use an excessive amount of solder. Best results are obtained with more heat and less solder.

Always hook the wire into the hole provided in each terminal, but do not twist the wire around the terminal more than half a turn. You might want to remove it if you should find that you have made a mistake!

Self-tapping Screws: In accordance with the most advanced factory assembly practice, self-tapping screws are provided for mounting most of the parts on the chassis. You can tell the difference between ordinary machine screws and self-tapping screws because the latter have a small slot cut through the threads. They are slightly tapered at the end, to make it easy to start them. With a little practice, you will be able to thread them into the different parts without any trouble. Actually, they take less time than using machine screws lock-washers, and nuts, and they do not work loose, for they are self-holding.

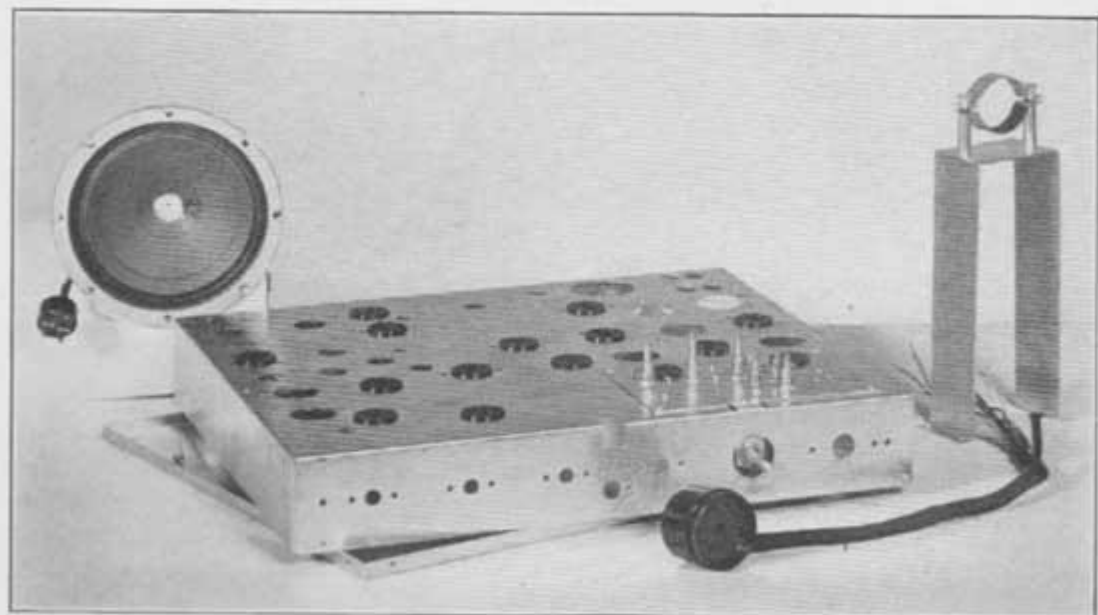

FIG. 48. THE CHASSIS IS FURNISHED WITH ALL HOLES PUNCHED, AND THE SOCKETS MOUNTED. LEFT, THE 6½-IN. SPEAKER; RIGHT, PICTURE TUBE SOCKET AND CABLE, AND THE TUBE MOUNTING BRACKET. NOTE THAT THE R.F. TUNING UNIT IS IN PLACE ON THE CHASSIS.

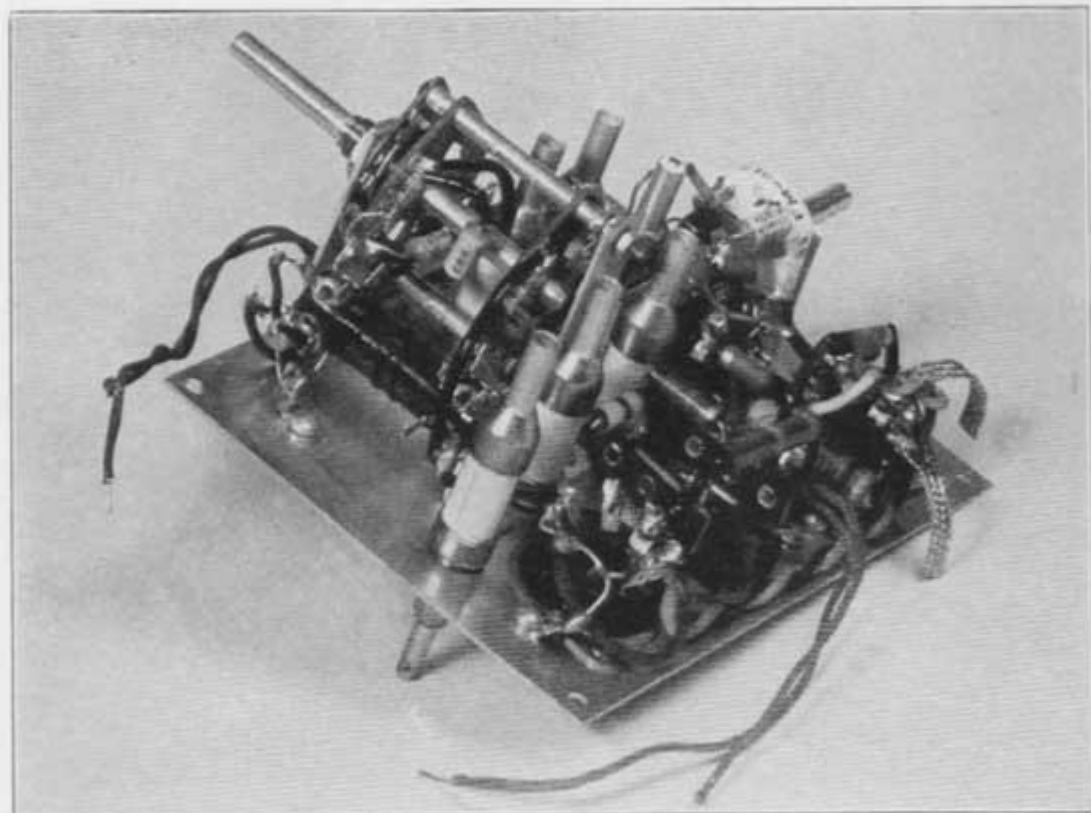

FIG. 49. THE R.F. TUNING UNIT SUPPLIED WITH THE ANDREA KIT IS ALREADY ASSEMBLED, WIRED, AND PRECISION-ADJUSTED SO THAT NO INSTRUMENTS ARE NEEDED TO ALIGN THE TUNING CIRCUITS.

- Press a soft rubber grommet into Hole A, next to Socket G.
- Get out a grid cap, with its shielded lead. Slip the lead through Hole A, solder the copper shield to 1 on Terminal Strip C, and connect the green wire to 2 on Terminal Strip C.
- NOTE: Twist the two following wires together. Do not run them separately.
- Connect 1 on Terminal Strip A to 7 on Socket H (yellow wire).
- Connect 2 on Terminal Strip A to 2 on Socket H (brown wire).
- Connect 1 on Socket H to 2 on Socket H (bare tinned wire).
- NOTE: Twist the two following leads together. Do not run them separately.
- Connect 7 on Socket H to 7 on Socket I (yellow wire).
- Connect 2 on Socket H to 8 on Socket I (brown wire).
- Connect 1 on Socket I to 8 on Socket I (bare tinned wire).
- Connect 4 on Socket I to 5 on Socket I (bare tinned wire).
- NOTE: Twist the two following wires together. Do not run them separately.
- Connect 7 on Socket H to 7 on Socket J (yellow wire).
- Connect 2 on Socket H to 2 on Socket J (brown wire).
- Connect 1 on Socket J to 2 and 3 on Socket J (bare tinned wire).
- NOTE: Twist the two following wires together. Do not run them separately.
- Connect 1 on Terminal Strip A to 7 on Socket K (yellow wire).
- Connect 2 on Terminal Strip A to 1 on Socket K (brown wire).
- Fasten Lug C to the underside of the chassis with a $\frac{1}{4}$ -in. self-tapping screw.

- Connect Lug C to 1 on Socket K and to 2 and 3 on Socket K (bare tinned wire).
- NOTE: Twist the two following wires together. Do not run them separately.
- Connect 2 on Socket K to 2 on Socket L (brown wire).
- Connect 7 on Socket K to 7 on Socket L (yellow wire).
- Fasten Lug D on the underside of the chassis with a $\frac{1}{4}$ -in. self-tapping screw.
- Connect Lug D to 1 on Socket L, and to 2 and 3 on Socket L (bare tinned wire).
- NOTE: Do not touch the plunger-type Trimmer Condenser on the R.F. Unit, for these Condensers have been adjusted at the Andrea factory to the television tuning channels.
- Mount the R.F. Tuning Unit on the top of the chassis, using four $\frac{1}{4}$ -in. self-tapping screws.
- NOTE: Twist the two following wires together. Do not run them separately.
- Connect 7 on Socket K to the wire from 7 on Socket M (yellow wire).
- Connect 1 on Socket K to the wire from 2 on Socket M (brown wire).
- There is a short piece of copper braid connected to 2 on Socket M. Solder the free end of this braid to the main chassis, as a ground connection.
- There is a short piece of copper braid connected to 8 on Socket M. Solder the free end of this braid to the main chassis, as a ground connection.
- Mount Transformer A (Part No. FM-602) on the top of the chassis, using four $\frac{1}{4}$ -in. self-tapping screws. Check the leads as they come through the four holes in the chassis, to be sure that they are in the positions shown in the drawing.
- Connect the Blue Lead from Transformer A to 1 on Socket N.
- Connect the Green Lead from Transformer A to 4 on Socket N.
- Mount Terminal Strip D on the side of the chassis, using two $\frac{5}{16}$ -in. 6-32 R.H. machine screws, with lock washers and nuts. This is a 6-lug Terminal Strip, and should be mounted so that the brackets are in the exact position shown in the drawing.
- Put a $\frac{3}{8}$ -in. rubber grommet in Hole B in the chassis.
- Put the lead from the large, insulated grid cap through the rubber grommet in Hole B, and connect the wire to 5 on Terminal Strip D.
- Connect the Red Lead from Transformer A to 5 on Terminal Strip D. Keep this wire close to the chassis.
- Mount Terminal Strip E at the rear of the chassis, using two $\frac{5}{16}$ in. 6-32 R.H. machine screws, lock washers, and nuts. This is a 6-lug Terminal Strip similar to D.
- NOTE: Twist the two following wires together. Do not run them separately.
- Connect the Brown Lead from Transformer A to 2 on Terminal Strip E. Keep this lead close to the angle of the chassis.
- Connect the Yellow Lead from Transformer A to 3 on Terminal Strip E. Keep this lead close to the angle of the chassis.
- Mount Terminal Strip F on the underside of the chassis, using a $\frac{1}{4}$ -in. self-tapping screw. This is a 4-lug Terminal Strip, with the mounting bracket at the end.
- Connect the Black Lead from Transformer A to 4 on Terminal Strip F.
- Mount Transformer B (Part No. FM-601) on the top of the chassis, using four $\frac{3}{8}$ -in. 8-32 F.H. machine screws, lock washers, and nuts. Check the leads as they come through the holes in the chassis, to make sure that they are in the positions shown in the drawing.
- NOTE: The solid wires coming from Transformer B are described below as being insulated with sleeving, while the stranded wires are referred to only by the color of the braided insulation. If you have difficulty in telling the colors of the different leads,

scrape off the impregnating compound, and you will be able to recognize the different colors.

- NOTE: Twist the two following wires together. Do not run them separately.
- Connect the solid wire with the Green Sleeving from Transformer B to 2 on Terminal Strip A.
- Connect the solid wire with Brown Sleeving from Transformer B to 1 on Terminal Strip A.
- NOTE: Twist the two following wires together. Do not run them separately. Keep them in the bend of the chassis.
- Connect the Brown Stranded Lead from Transformer B to 4 on Terminal Strip E.
- Connect the Green Stranded Lead from Transformer B to 5 on Terminal Strip E.
- NOTE: Twist the two following wires together. Do not run them separately.
- Connect the solid wire with White Sleeving from Transformer B to 2 on Socket O.
- Connect the solid wire with Red Sleeving from Transformer B to 8 on Socket O.
- NOTE: Twist the two following wires together. Do not run them separately.
- Connect the Red Stranded Lead from Transformer B to 6 on Socket O.
- Connect the Yellow Stranded Lead from Transformer B to 4 on Socket O.
- Mount Terminal Strip G on the underside of the chassis, using a 5/16-in. 6-32 R.H. machine screw, lock washer, and nut. This is a 3-lug Terminal Strip, with the mounting bracket at the center.
- Connect the Red-and-Yellow Stranded Lead from Transformer B to 2 on Terminal Strip G.
- NOTE: Twist the two following wires together. Do not run them separately.
- Connect the Blue Stranded Lead from Transformer B to 1 on Terminal Strip G.
- Connect the Black Stranded Lead from Transformer B to 3 on Terminal Strip G.
- Insert the end of the Line Cord in the corner hole at the rear of the chassis, and work the grommet into the hole. That keeps the cord from pulling out, and provides extra insulation where the cord passes through the chassis.
- Connect one wire from the Line Cord to 1 on Terminal Strip G.
- Mount the Safety Switch on the side of the chassis, using two 1/4-in. self-tapping screws.
- Connect the other wire from the Line Cord to 1 on the Safety Switch.
- NOTE: This switch is closed only when the base plate is in position on the chassis. Consequently, the power is cut off when the base plate is removed.
- Mount the Volume Control & Switch (Part No. FM-589) at the front of the chassis, clamping it firmly with the nut provided.
- NOTE: Twist the two following wires together. Do not run them separately.
- Connect 2 on the Safety Switch to 1 on the Volume Control & Switch (yellow wire).
- Connect 3 on Terminal Strip G to 2 on the Volume Control & Switch (brown wire).
- NOTE: Twist the two following wires together. Do not run them separately.
- Connect 3 on Terminal Strip G to 2 on Terminal Strip E (brown wire).
- Connect 1 on Terminal Strip G to 3 on Terminal Strip E (yellow wire).
- Mount the Pilot Light Bracket at the front of the chassis, using a 1/4-in. 6-32 machine screw with a thin, flat head, lock washer, 3/8-in. brass washer, and nut.
- Screw the bulb into the Pilot Light socket.
- NOTE: Twist the two following wires together. Do not run them separately.
- Connect 2 on Socket J to one terminal of the Pilot Light (black wire).

Connect 7 on Socket J to the other Terminal of the Pilot Light (black wire). This completes the Assembly Stage No. 1. **IMPORTANT:** Before proceeding further, check over every step in the preceding instructions to see that:

1. each connection is correct
2. every soldered joint is perfect
3. the color coding is right
4. there is no mistake in the Transformer leads

If possible, have someone else double check your work, for it is easy to overlook one's own mistakes!

Do Not, Under Any Circumstances, Connect The Set To The Light Socket!

ASSEMBLY STAGE No. 2

Mounting and Wiring the Filter Condensers, Chokes, and IF Transformers

Pick out the following parts which will be required in the next assembly and wiring steps:

- 2—Filter condensers (Part No. HC-164)
- 3—Small condenser-mounting ring clamps
- 4— $\frac{1}{2}$ -in. 6-32 R.H. machine screws
- 4—Cadmium plated lock washers for above
- 4—Large 6-32 nuts for above
- 26— $\frac{1}{4}$ -in. self-tapping screws.
- 1—Filter Condenser (Part No. HC-167)
- 3—3-lug terminal strips with the mounting bracket at the center (Part No. FM-361)
- 2—Filter condensers (Part No. HC-166)
- 3—3-lug terminal strips with the mounting bracket on second lug (Part No. FM-363)
- 1—Filter condenser (Part No. HC-165)
- 1—Audio choke (Part No. FM-603)
- 1— $\frac{3}{8}$ -in. rubber grommet
- 1—Audio choke (Part No. FM-604)
- 1—4-lug terminal strip with the mounting bracket on the second lug (Part No. FM-619)
- 1—Filter condenser (Part No. HC-168)
- 6— $\frac{5}{16}$ in. 6-32 R.H. machine screws
- 12—Lock washers for above
- 10—Nuts for above
- 1—2-lug terminal strip with the mounting bracket at the center (Part No. FM-360)
- 6—Soldering lugs
- 1—Filter condenser (Part No. HC-163)
- 1—Large condenser-mounting ring clamp
- 1—Picture tube socket and cable (Part No. FM-605)
- 1—2-lug terminal strip with the mounting bracket at the end (Part No. FM-621)
- 1—5-lug terminal strip with the mounting bracket at the end (Part No. FM-616)
- 1—I.F. transformer (Part No. SA-154)
- 2—I.F. transformers (Part No. SA-153)

- 2—Trimmer Condenser (Part No. FM-528)
- 1—R.F. shield (Part No. EP-192)
- 1—Cable tie-string clamp

With these parts in readiness, proceed with the construction and wiring as shown in ¹ Assembly Stage Drawing No. 2.

- Mount Filter Condenser A (Part No. HC-164, .05-2500 V.). Fasten this to the top of the chassis with a ring clamp, using two ¼-in. self-tapping screws. Close the ring with a ½-in. 6-32 R.H. machine screw, cadmium-plated lock washer, and large nut.
- Connect 1 on Filter Condenser A to 6 on Socket A (blue wire).
- Mount Filter Condenser B (Part No. HC-164, .05-2500 V.). Fasten this to the top of the chassis with a ring clamp, using two ¼-in. self-tapping screws. Close the ring with a ½-in. 6-32 R.H. machine screw, cadmium-plated lock washer, and large nut.
- Connect 1 on Filter Condenser B to 3 on Socket A (blue wire).
- NOTE: Twist the two following wires together. Do not run them separately. Keep them in the bend of the chassis.
- Connect 2 on Filter Condenser A to 3 on Terminal Strip D (H.V. blue wire).
- Connect 2 on Filter Condenser B to 2 on Terminal Strip D (H.V. blue and white wire).
- Connect 1 on the Speaker Plug Socket to 3 on Socket H (blue wire).
- Connect 2 on the Speaker Plug Socket to 4 on Socket H (red wire).
- Mount Filter Condenser C (Part No. HC-167, 8-350 V.) on the top of the chassis, using the large nut provided.
- Connect 1 on Filter Condenser C to 2 on the Speaker Plug Socket (red wire).
- Mount Terminal Strip H, using a ¼-in. self-tapping screw. This is a 3-lug Terminal Strip, with the mounting bracket at the center.
- Connect 1 on Filter Condenser C to 1 on Terminal Strip H (red wire).
- Connect 2 on Terminal Strip H to 8 on Socket I (black wire).
- Connect 2 on Terminal Strip H to 3 on the Volume Control & Switch (black wire).
- Mount Filter Condenser D (Part No. HC-166, 25-475 V.) on the top of the chassis, using the large nut provided.
- Connect 1 on Filter Condenser D to 3 on the Speaker Plug Socket (red wire).
- Mount Terminal Strip I on the underside of the chassis, using a ¼-in. self-tapping screw, and put a soldering lug under the head of the screw. This is a 3-lug Terminal Strip, with the mounting bracket at the center.
- Connect 1 on Filter Condenser D to 1 on Terminal Strip I (red wire).
- Mount Terminal Strip J on the underside of the chassis, using a ¼-in. self-tapping screw. This is a 3-lug Terminal Strip, with the mounting bracket between the first and second lugs.
- Connect 1 on Filter Condenser D to 1 on Terminal Strip J (brown wire). Keep this wire close to the chassis.
- Mount Filter Condenser E (Part No. HC-165, 25-500 V.) on the top of the chassis, using the large nut provided.
- Connect 1 on Filter Condenser E to 8 on Socket O (red wire).
- Mount Filter Condenser F (Part No. HC-166, 25-475 V.) on the top of the chassis, using the large nut provided.
- Connect 1 on Filter Condenser F to 4 on the Speaker Plug Socket (red wire).
- Mount Audio Choke A (Part No. FM-603) on the top of the chassis, using four

¹ Furnished separately with this book.

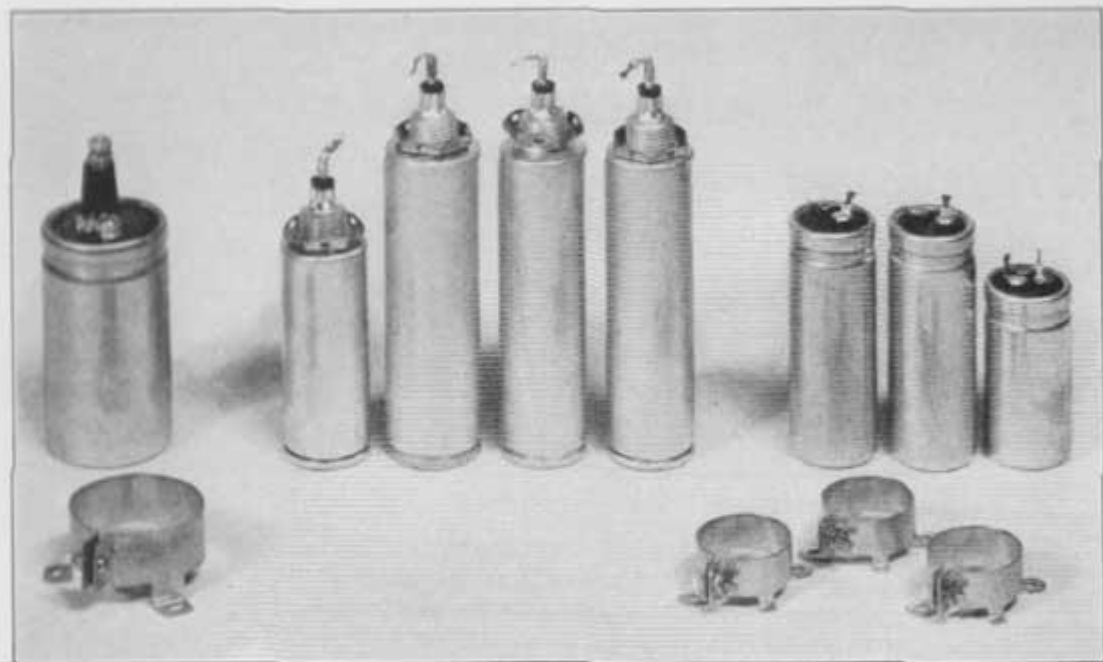

FIG. 50. FILTER CONDENSERS REQUIRED IN THIS ASSEMBLY STAGE. THE FOUR AT THE CENTER ARE MOUNTED WITH NUTS, WHILE THE OTHERS ARE HELD TO THE CHASSIS WITH RING CLAMPS.

$\frac{1}{4}$ -in. self-tapping screws. See that the leads come out directly over the hole in the chassis.

- NOTE: Twist the two following wires together. Do not run them separately. Keep them close to the chassis.
- Connect the Yellow Lead from Audio Choke A to 1 on Filter Condenser F.
- Connect the Black Lead from Audio Choke A to 1 on Filter Condenser E.
- Press a soft-rubber grommet into Hole C.
- Mount Audio Choke B (Part No. FM-604) on the top of the chassis, using two $\frac{1}{4}$ -in. self-tapping screws. Be sure that the leads come out over the rubber grommet in Hole C, as shown in the drawing.
- Connect the Black Lead from Audio Choke B to 4 on the Speaker Plug Socket.
- Mount Terminal Strip K on the underside of the chassis, using a $\frac{1}{4}$ -in. self-tapping screw. This is a 4-lug Terminal Strip with the mounting bracket on Lug 2.
- Connect the Yellow Lead from Audio Choke B to 1 on Terminal Strip K.
- Connect 2 on Terminal Strip K to 5 on Socket D (black wire).
- Mount Filter Condenser G (Part No. HC-168, 12-450 V., 8-400 V.) on the top of the chassis with a ring clamp, using two $\frac{1}{4}$ -in. self-tapping screws. Close the ring with a $\frac{1}{2}$ -in. 6-32 R.H. machine screw, cadmium-plated lock washer, and large nut.
- Connect 1 (green dot) on Filter Condenser G to 4 on Socket F (brown wire).
- Mount Terminal Strip L on the rear of the chassis. This is a 3-lug Terminal Strip with the mounting bracket at the center. Put a $\frac{5}{16}$ -in. 6-32 R.H. machine screw through the bracket, put a lock washer on the screw, and thread the screw into a $\frac{5}{8}$ -in. hexagonal pillar. Fasten the pillar to the rear of the chassis, using a $\frac{5}{16}$ -in. 6-32 R.H. machine screw, with a lock washer under the head.
- Connect 2 (red dot) on Filter Condenser G to 3 on Terminal Strip L (red wire).
- Mount Terminal Strip M on the side of the chassis, using a $\frac{5}{16}$ -in. 6-32 R.H. machine

screw, lock washer, and nut, and put a soldering lug under the lock washer. This is a 2-lug Terminal Strip, with the mounting bracket at the center.

- Connect 3 on Terminal Strip L to 1 on Terminal Strip M (red wire). Keep this wire close to the bend in the chassis.
- Connect 1 on Terminal Strip K to 3 on Terminal Strip L (red wire).
- Mount Filter Condenser H (Part No. HC-163, .2-2500 V.) on the top of the chassis with a ring clamp, using three $\frac{1}{4}$ -in. self-tapping screws.
- Connect 1 on Filter Condenser H to 4 on Terminal Strip F (bare tinned wire).
- Put the heavy cable from the Picture Tube Socket through Hole D, so that the braided covering over the wires goes through the hole, but no further, and bring the braided tie-string off to the side in the direction of the Antenna & Ground Terminal Strip at the rear of the chassis. Bring the heavy, rubber-covered wire out so that it points toward the front of the chassis.
- Connect the Red Lead from the Cable to 2 on Filter Condenser H.
- NOTE: Twist the two following wires together. Do not run them separately.
- Connect the Brown Lead from the Cable to 4 on Terminal Strip E.
- Connect the Yellow Lead from the Cable to 5 on Terminal Strip E.
- Mount Terminal Strips N and O on the underside of the chassis. Put a $\frac{1}{4}$ -in. self-tapping screw through the mounting bracket of N, and the left-hand bracket of O. Use another $\frac{1}{4}$ -in. self-tapping screw through the other bracket of O. Terminal Strip N has 2 lugs, with the mounting bracket at the end. Terminal Strip O has 5 lugs, with the mounting brackets at the ends.
- Connect the Black Lead from the Cable to 2 on Terminal Strip N.
- Connect the Green-and-White Lead from the Cable to 4 on Terminal Strip D.
- Connect the Blue-and-White Lead from the Cable to 2 on Terminal Strip D.
- Connect the Green Lead from the Cable to 1 on Terminal Strip D.
- Connect the Blue Lead from the Cable to 3 on Terminal Strip D.
- Mount I.F. Transformer A (Part No. SA-154) on the top of the chassis, and fasten it in place with two 6-32 nuts and lock washers. Be sure that the post, indicated on the drawing, is at the right, looking at the chassis in the position illustrated.
- Connect 1 (blue dot) on I.F. Transformer A to 8 on Socket L (blue wire). NOTE: Keep this wire up from the chassis.
- Mount Terminal Strip P on the underside of the chassis, using a $\frac{1}{4}$ -in. self-tapping screw. This is a 3-lug Terminal Strip, with the mounting bracket between lugs 2 and 3.
- Connect 2 (red dot) on I.F. Transformer A to 3 on Terminal Strip P (red wire).
- Mount Terminal Strip Q at the side of the chassis, using a $\frac{5}{16}$ -in. 6-32 R.H. machine screw, lock washer, and nut, with a soldering lug between the lock washer and the bracket. This is a 3-lug Terminal Strip, with the mounting bracket between lugs 1 and 2.
- Connect 2 on Terminal Strip P to 2 on Terminal Strip Q (red wire).
- Connect 1 on Terminal Strip P to 6 on Socket L (brown wire).
- Connect 3 on Terminal Strip Q to 6 on Socket K (brown wire).
- Connect 2 on Terminal Strip Q to 2 on Terminal Strip R (red wire). The latter is already mounted on the R.F. Tuning Unit.
- Connect 3 (green dot) on I.F. Transformer A to 5 on Socket E (green wire). NOTE: Keep this wire up from the chassis.
- Connect 4 (black dot) on I.F. Transformer A to Lug D (bare tinned wire).

- Mount I.F. Transformer B (Part No. SA-153) on the top of the chassis, and fasten it in place with two 6-32 nuts and lock washers. Be sure that the Post, indicated in the drawing, is at the left, looking at the chassis in the position shown.
- Connect 1 (blue dot) on I.F. Transformer B to 8 on Socket K (blue wire).
NOTE: Allow $\frac{1}{2}$ -in. extra length on this wire, as it must pass over a by-pass Condenser to be mounted in Stage No. 5.
- Connect 2 (red dot) on I.F. Transformer B to 1 on Terminal Strip Q (red wire).
- Connect 3 (green dot) on I.F. Transformer B to 4 on Socket L (green wire). NOTE: Keep this wire away from the chassis.
- Fasten Lug E to the side of the chassis, using a $\frac{5}{16}$ -in. 6-32 machine screw, lock washer and nut.
- Connect 4 (black dot) on I.F. Transformer B to Lug E (black wire).
- Mount Trimmer Condenser D on the underside of the chassis, using a $\frac{1}{4}$ -in. self tapping screw.
- Mount I.F. Transformer C (Part No. SA-153) on the top of the chassis, and fasten it in place with two 6-32 nuts and lock washers. Be sure that the Post, indicated in the drawing, is at the left, looking at the chassis in the position shown.
- Connect the blue wire from 8 on Socket P to 1 (blue dot) on I.F. Transformer C. NOTE: Keep this wire away from the chassis.
- Connect the red wire from 1 on Terminal Strip R to 2 (red dot) on I.F. Transformer C.
- Connect 3 (green dot) on I.F. Transformer C to 4 on Socket K (green wire).
- Fasten Lug F on the underside of the chassis with a $\frac{1}{4}$ -in. self-tapping screw.
- Connect 4 (black dot) on I.F. Transformer C to Lug F (black wire).
- Mount Trimmer Condenser A (Part No. FM-528) at the side of the chassis, using a $\frac{1}{4}$ -in. self-tapping screw. Be sure that the adjusting screw is in line with the hole in the side of the chassis.
- Connect 2 (black dot) on trimmer Condenser A to the lug on the bracket of Terminal Strip Q (brown wire).
- Connect 1 on Trimmer Condenser A to 5 on I.F. Transformer B (brown wire).
- Mount the R.F. Shield on the underside of the chassis. First remove the nut and lock washer from the lower mounting screw of I.F. Transformer C, and slip the right hand end of the R.F. Shield over the screw. Then replace the lock washer and nut. Fasten the left hand end of the R.F. Shield with a $\frac{1}{4}$ -in. self-tapping screw, with a soldering lug under the head of the screw. This is Lug G.
- Connect Lug G to 1 on Socket H (bare tinned wire).
- Fasten the Clamp for holding the tie-string of the Picture Tube Cable to the rear of the chassis, using a $\frac{5}{16}$ -in. 6-32 R.H. machine screw, lock washer, and nut.
- Secure the Cable tie-string to the Clamp, pulling it tight enough so that any strain will come on the Clamp, and not on the soldered connections.

This completes Assembly Stage No. 2. **IMPORTANT:** Before proceeding further, check over every step in the preceding instructions to see that:

1. each connection is correct
2. every soldered joint is perfect
3. the color coding is right
4. there is no mistake in the Part Numbers of the Filter Condensers
5. the I.F. Transformers are in the correct positions, as indicated by the Posts
6. each of the color-coded wires in the Picture Tube Cable goes to the right place

FIG. 51. TWO OF THE GLASS TUBES REQUIRE THE METAL SHIELDS SHOWN HERE. THE BASES ARE MOUNTED ON THE CHASSIS IN ASSEMBLY STAGE NO. 1, BUT THE SHIELDS ARE NOT PUT IN PLACE UNTIL THE TUBES ARE



PUT INTO THE SOCKETS DURING ASSEMBLY STAGE NO. 6. THESE SHIELDS GO ON THE TUBES IN SOCKETS A AND G. THE OUTLINES OF THE BASES ARE SHOWN IN ASSEMBLY STAGE DRAWING NO. 1.

If possible, have someone else double-check your work, for it is easy to overlook one's own mistakes. The importance of this cannot be over-emphasized, because, as the work proceeds, it becomes increasingly difficult to locate errors made in previous Assembly Stages. The time you spend now in double-checking may save you hours of searching, and possibly the expense of burned-out parts, later on.

Do Not, Under Any Circumstances, Connect The Set To The Light Socket!

ASSEMBLY STAGE No. 3

Mounting and wiring the Controls, RF Chokes, Trimmers, and Small Parts

Pick out the following parts which will be required in the next assembly and wiring steps illustrated in ¹ Assembly Stage Drawing No. 3:

- 1—Tone control (Part No. FM-588)
- 1—Short shielded lead
- 1—Grid cap and lead
- 1—Sound I.F. transformer (Part No. SA-152)
- 1—3-lug terminal strip with the mounting bracket at the end (Part No. FM-620)
- 1—Brightness control (Part No. FM-593)
- 2—2-lug terminal strips with the mounting bracket at the center (Part No. FM-360)
- 3—Trimmer condensers (Part No. FM-528)
- 1—Focus control (Part No. FM-595)
- 1—3-lug terminal strip with the mounting bracket between the first and second lugs (Part No. FM-363)
- 1—Contrast control (Part No. FM-591)
- 6—Soldering lugs
- 14— $\frac{1}{4}$ -in. self-tapping screws
- 4— $\frac{1}{4}$ -in. 6-32 machine screws with thin, flat heads
- 2—5-16-in. 6-32 R.H. machine screws
- 2—nuts for above
- 6—lock washers for above
- 1—Long 2-conductor antenna cable
- 1—Length of varnished tubing
- 1—R.F. choke (Part No. SA-160)

¹ Furnished separately with this book.

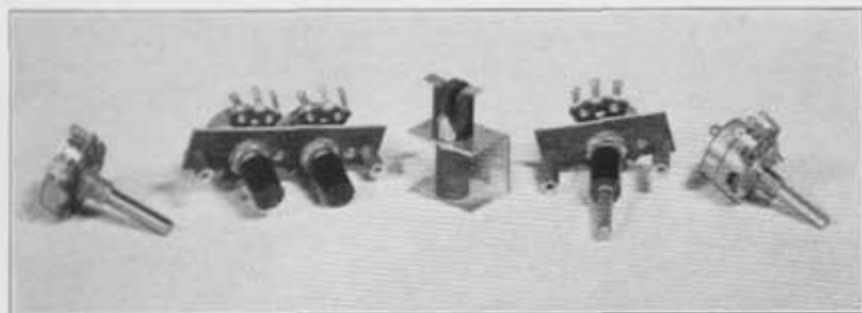

FIG. 52. LEFT TO RIGHT: PLAIN CONTROL RESISTOR, CENTERING CONTROL UNIT, SAFETY SWITCH, FOCUS CONTROL, AND COMBINED VOLUME CONTROL AND SWITCH. NOTE THE EXTRA INSULATION ON THE CENTERING AND FOCUS CONTROLS, AND THE TWO PILLARS WITH WHICH THEY ARE MOUNTED.

- 1—R.F. choke (Part No. SA-158)
- 1—R.F. choke (Part No. SA-161)
- 1—R.F. choke (Part No. SA-159)
- 5—2-lug terminal strips with the mounting bracket serving as one of the lugs, right hand and left hand.
- 1—Soft rubber grommet
- 1—Picture height control (Part No. FM-599)
- 1—Vertical hold control (Part No. FM-598)
- 1—Picture width control (Part No. FM-597)
- 1—Horizontal hold control (Part No. FM-600)
- 1—Centering control unit (Part Nos. FM-596 and FM-596)

- Mount the Tone Control (Part No. FM-588) on the front of the chassis, clamping it firmly with the nut provided.
- Connect 3 on the Tone Control to the Lug on the mounting bracket of Terminal Strip M (black wire).
- Press a soft rubber grommet into Hole E, next to Socket A.
- Connect the inside conductor (green wire) of the short Shielded Lead to 5 on Socket H. NOTE: This Shielded Lead does not have a grid cap.
- Connect the other end of the inside conductor (green wire) to 1 on the Tone Control.
- Connect the copper shield of the Shielded Lead to the Lug on the mounting bracket of Terminal Strip I.
- Mount Terminal Strip AA on the underside of the chassis, using a $\frac{1}{4}$ -in. self-tapping screw. This is a 2-lug Terminal Strip, with the mounting bracket serving as one lug. Put a soldering lug under the head of the screw.
- Get out a grid cap, with its shielded lead. Slip the lead through Hole E, solder the copper shield to the soldering lug on the mounting bracket of Terminal Strip AA, and connect the inside conductor (green wire) to 2 on Terminal Strip AA.
- Mount the Sound I.F. Transformer (Part No. SA-152) with the green dot toward the front of the chassis, and the blue dot toward the rear of the chassis. CHECK THIS CAREFULLY! Use two $\frac{1}{4}$ -in. self-tapping screws, and put a soldering lug under the mounting bracket screw at the rear (blue dot) end. At the front (green dot) end, use the mounting screw also to secure the mounting bracket of Terminal Strip T. This is a 3-lug Terminal Strip with the mounting bracket at the end.
- Mount the Contrast Control (Part No. FM-591) on the front of the chassis, clamping it firmly with the nut provided.

- Connect 2 on the Contrast Control to 3 on Terminal Strip T (black wire).
- Mount Terminal Strip U on the underside of the chassis, using a ¼-in. self-tapping screw. This is a 2-lug Terminal Strip with the mounting bracket at the center.
- Connect 1 on the Contrast Control to 2 on Terminal Strip U (green wire).
- NOTE: No connection is made to 3 on the Contrast Control at any time.
- Connect the green wire on 1 of Terminal Strip S to 2 on Terminal Strip U.
- Mount Trimmer Condenser B (Part No. FM-528) on the underside of the chassis, using a ¼-in. self-tapping screw.
- Connect 1 (black dot) on Trimmer Condenser B to 3 on Terminal Strip T (black wire).
- Connect 1 (black dot) on Trimmer Condenser B to 3 on Socket I (black wire).
- Connect 2 on Trimmer Condenser B to 4 on Socket I (bare tinned wire).
- Connect 2 on Trimmer Condenser B to 4 on Sound I.F. Transformer (green wire).
- Mount Trimmer Condenser C (Part No. FM-528) on the underside of the chassis, using a ¼-in. self-tapping screw.
- Connect 1 (black dot) on Trimmer Condenser C to the lug on the lower mounting bracket of the Sound I.F. Transformer (black wire).
- Connect 2 on Trimmer Condenser C to 1 on the Sound I.F. Transformer (bare tinned wire with varnished tubing).
- Connect 1 on the Sound I.F. Transformer to 8 on Socket J (blue wire).
- Mount Terminal Strip V on the underside of the chassis, using a ¼-in. self-tapping screw. This is a 2-lug Terminal Strip with the mounting bracket at the center.
- Connect 2 on the Sound I.F. Transformer to 2 on Terminal Strip V (bare tinned wire).
- Connect 1 on Terminal Strip V to 3 on the Speaker Plug Socket (red wire).
- Connect 1 (black dot) on Trimmer Condenser D to Lug F (black wire).
- Connect 2 on Trimmer Condenser D to 5 on I.F. Transformer C (bare tinned wire).
- Mount Trimmer Condenser E (Part No. FM-528) on the underside of the chassis, using a ¼-in. self-tapping screw.
- Connect 1 (black dot) on Trimmer Condenser E to 4 on I.F. Transformer A (bare tinned wire with varnished tubing).
- Connect 2 on Trimmer Condenser E to 5 on I.F. Transformer A (bare tinned wire with varnished tubing).
- Mount the Brightness Control (Part No. FM-593) on the front of the chassis, clamping it firmly with the nut provided.
- Connect 2 on the Brightness Control to 4 on Terminal Strip E (red wire). Keep this wire close to the chassis all the way.
- Connect 3 on the Brightness Control to 2 on Terminal Strip Q (red wire).
- Mount Terminal Strip W at the side of the chassis, using a 5/16-in. 6-32 R.H. machine screw, lock washer, and nut, and put a soldering lug under the washer. This is a 3-lug Terminal Strip with the mounting bracket between the first and second lugs.
- Arrange the long, 2-conductor, shielded Antenna Cable in the position shown in the Drawing.
- Connect the braided copper lead from the shield of the Antenna Cable to the G terminal of the Antenna Terminal Strip.
- Connect the copper shield at the other end to the lug on the bracket of Terminal Strip W.

FIG. 53. THE VIDEO IF TRANSFORMERS ARE MATCHED AT THE FACTORY, AND DO NOT REQUIRE ANY FURTHER ADJUSTMENT. IN FRONT, THE FIVE TRIMMER CONDENSERS, ONE OF WHICH IS PUT ON IN ASSEMBLY STAGE

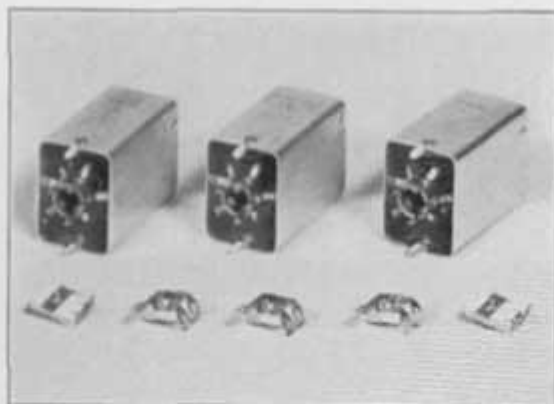

NO. 2, AND FOUR IN ASSEMBLY STAGE NO. 3. BE SURE TO LOCATE THEM SO THAT THE ADJUSTING SCREWS ARE IN LINE WITH THE HOLES IN THE CHASSIS, FOR SCREWDRIVER SETTING.

- Connect one blue wire of the Antenna Cable to the center lug A of the Antenna Terminal Strip.
- Connect the other blue wire of the Antenna Cable to the outside A lug of the Antenna Terminal Strip.
- At the other end of the Antenna Cable, connect one blue wire to 2 on Terminal Strip W.
- Connect the other blue wire of the Antenna Cable to 3 on Terminal Strip W. NOTE: It does not matter which wires are connected to the lugs at the Antenna Terminal Strip, as they are interchangeable.
- Connect 1 on Terminal Strip W to 2 on Terminal Strip N (H.V. black wire). NOTE: Keep this wire close to the chassis, and clear of the contacts on Socket N.
- NOTE: Keep the two following wires twisted together. Do not run them separately.
- Connect one of the green wires from the Antenna Coil of the R.F. Tuning Unit to 3 on Terminal Strip W.
- Connect the other green wire from the Antenna Coil of the R.F. Tuning Unit to 2 on Terminal Strip W.
- Mount the Focus Control (Part No. FM-595) at the front of the chassis, using two $\frac{1}{4}$ -in. 6-32 machine screws with thin, flat heads and lock washers.
- NOTE: Twist the two following wires together. Do not run them separately. Keep these wires close to the chassis.
- Connect 1 on the Focus Control to 3 on Terminal Strip O (H.V. red wire).
- Connect 3 on the Focus Control to 4 on Terminal Strip O (H.V. brown wire).
- Mount R.F. Choke A (Part No. SA-160) on the underside of the chassis, using a $\frac{1}{4}$ -in. self-tapping screw. Put a soldering lug between the mounting bracket and the head of the screw.
- Connect the soldering lug on the mounting bracket of R.F. Choke A to 1 on Socket D (bare tinned wire).
- Mount R.F. Choke B (Part No. SA-158) on the underside of the chassis, using a $\frac{1}{4}$ -in. self-tapping screw. Put a soldering lug between the mounting bracket and the head of the screw.
- Connect 1 (red dot) on R.F. Choke B to the soldering lug on the mounting bracket of R.F. Choke B (black wire).
- Connect the soldering lug on the mounting bracket of R.F. Choke B to 2 on Socket E (bare tinned wire).
- Connect 1 on Terminal Strip E to G on Antenna Terminal Strip (bare tinned wire).
- Mount R.F. Choke C (Part No. SA-161) on the underside of the chassis, using a $\frac{1}{4}$ -in.

self-tapping screw. Put a soldering lug between the mounting bracket and the head of the screw.

- Connect the soldering lug on the mounting bracket of R.F. Choke C to 1 on Socket F (bare tinned wire).
- Connect the soldering lug on the mounting bracket of R.F. Choke C to 3 on Filter Condenser G (bare tinned wire with varnished tubing).
- Connect 1 (red dot) on R.F. Choke C to 8 on Socket E (bare tinned wire).
- Mount Terminal Strip X on the underside of the chassis, using a $\frac{1}{4}$ -in. self-tapping screw. This is a 2-lug Terminal Strip with the mounting bracket serving as one lug. NOTE: No connection is made to lug 1.
- Connect 2 on Terminal Strip X to 2 (black dot) on R.F. Choke C (bare, tinned wire).
- Mount R.F. Choke D (Part No. SA-159) and Terminal Strip Y on the underside of the chassis, using the same $\frac{1}{4}$ -in. self-tapping screw. This is a 2-lug Terminal Strip with the mounting bracket serving as one lug.
- Connect 2 (black dot) on R.F. Choke D to 3 on Socket F (blue wire).
- Connect the heavy, rubber-covered conductor from the Picture Tube Cable to 1 (red dot) on R.F. Choke D. NOTE: Keep this wire toward the front of the chassis, and away from the rear of the chassis.
- Connect 1 on Terminal Strip Y to 8 on Socket F (bare tinned wire with varnished tubing).
- Connect 2 on Terminal Strip Y to 5 on Socket F (bare tinned wire with varnished tubing).
- Mount the Picture Height Control (Part No. FM-599) at the rear of the chassis, clamping it firmly with the nut provided.
- Mount Terminal Strip Z at the side of the chassis, using a 5/16-in. 6-32 R.H. machine screw, lock washer, and nut. This is a 2-lug Terminal Strip with the mounting bracket serving as one lug.
- NOTE: Keep the two following wires close to the bend in the chassis.
- Connect 3 on the Picture Height Control to 2 on Terminal Strip Z (brown wire).
- Connect 2 on the Picture Height Control to 5 on Socket A (green wire).
- Mount the Vertical Hold Control (Part No. FM-598) at the rear of the chassis, clamping it firmly with the nut provided.
- Connect 3 on the Vertical Hold Control to 5 on Socket B (H.V. green and white wire).
- Mount the Picture Width Control (Part No. FM-597) at the rear of the chassis, clamping it firmly with the nut provided.
- Connect 3 on the Picture Width Control to 1 on the Picture Height Control (bare tinned wire with varnished tubing).
- Connect 3 on the Picture Width Control to 2 on Terminal Strip L (bare tinned wire with varnished tubing).
- Connect 2 on the Picture Width Control to 3 on Terminal Strip C (red wire).
- Connect 1 on the Picture Width Control to 1 on Terminal Strip J (brown wire).
- Mount the Horizontal Hold Control (Part No. FM-600) at the rear of the chassis, clamping it firmly with the nut provided.
- Mount the Centering Controls unit, comprising the Vertical Centering Control (Part No. FM-596) and the Horizontal Centering Control (Part No. FM-596) at the rear of the chassis, using two $\frac{1}{4}$ -in. 6-32 machine screws with thin, flat heads and lock washers.

FIG. 54. THE FIVE RF CHOKES HAVE DIFFERENT PART NUMBERS STAMPED ON THEM. BE SURE NOT TO MAKE A MISTAKE IN THE NUMBERS, OR YOU WILL

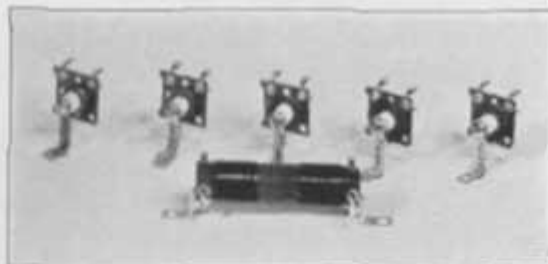

UPSET THE FUNCTIONING OF THE CIRCUITS. FRONT, THE SOUND IF TRANSFORMER. ALL THESE PARTS ARE REQUIRED IN ASSEMBLY STAGE NO. 3.

- Connect 3 on the Vertical Centering Control to 1 on Terminal Strip O (H.V. yellow wire).
- Connect 3 on the Vertical Centering Control to 3 on the Horizontal Centering Control (H.V. yellow wire).
- Connect 1 on the Vertical Centering Control to 2 on Filter Condenser H (H.V. yellow wire).
- Connect 1 on the Vertical Centering Control to 1 on the Horizontal Centering Control (H.V. yellow wire).
- Connect 1 on the Horizontal Centering Control to 1 on Socket N (H.V. yellow wire).
- Mount Terminal Strip AB on the underside of the chassis, using a $\frac{1}{4}$ -in. self-tapping screw. This is a 2-lug Terminal Strip with the mounting bracket at the end.
- Connect 2 on Terminal Strip AB to 1 of Terminal Strip B (green wire).
- Connect 5 on Socket C to 6 of Terminal Strip E (brown wire).

This completes Assembly Stage No. 3. **IMPORTANT:** Before proceeding further, check over every step in the preceding instructions to see that:

1. each connection is correct
2. every soldered joint is perfect
3. the color coding is right
4. there is no mistake in the Part Numbers of the Picture Controls, I.F. Transformers, R.F. Chokes, and their numbered terminals.
5. you have not been confused by the increasing number of Terminal Strips.

If possible, have someone else double check your work for, at this point, if you have made a mistake, it will be difficult to locate it later on, and may cause you to make other errors in connecting the resistors and condensers. Don't let your impatience to complete the work cause you to be careless or to relax your efforts to be certain that each step is correct before you go on to the next one.

Do Not, Under Any Circumstances, Connect The Set To The Light Socket!

ASSEMBLY STAGE No. 4

Wiring the Resistors

Assembly Stage No. 4 is concerned chiefly with the connection of the various types and sizes of fixed resistors. This Stage must be carried out with the greatest care and thoroughness, for if one resistor is put in the wrong place, or the wrong value used, it will upset the functioning of the entire receiver. Mistakes can be avoided if you will be patient and careful in checking the sizes and colors of the resistors against the Resistor Chart provided here.

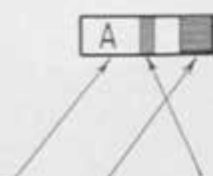

	Part No.			
A (2)	Brown	Black	Green	GR-10
B (2)	Brown	Black	Orange	GR-37
C (2)	Brown	Black	Red	GR-78
D (6)	Brown	Black	Yellow	GR-81
E (1)	Brown	Black	Brown	GR-84
F (2)	Brown	Green	Brown	GR-30
G (1)	Brown	Green	Green	GR-80
H (1)	Brown	Green	Orange	GR-83
I (8)	Green	Black	Yellow	GR-13
J (2)	Green	Black	Orange	GR-14
K (2)	Green	Black	Brown	GR-82
L (1)	Green	Blue	Red	GR-96
M (9)	Red	Black	Green	GR-23
O (4)	Red	Black	Red	GR-40
P (2)	Red	Yellow	Yellow	GR-46
Q (1)	Red	Green	Orange	GR-85
R (1)	Yellow	Black	Red	GR-33
T (2)	Yellow	Blue	Red	GR-77
U (1)	Violet	Black	Black	GR-57
V (1)	Violet	Green	Orange	GR-86
W (1)	Orange	Black	Red	GR-79
X (2)	Orange	Black	Green	GR-87

	Part No.			
AA (2)	Brown	Black	Yellow	GR-90
BB (5)	Brown	Black	Green	GR-91
CC (3)	Green	Green	Orange	GR-88
EE (1)	Yellow	Black	Brown	GR-1



AAA (3)	Green	Black	Orange	GR-92
BBB (1)	Orange	Black	Orange	GR-20
CCC (1)	White	Black	Orange	GR-93
DD (1)	Red	Black	Orange	GR-50
DDD (1)	vitreous resistor			GR-94
EEE (1)	vitreous resistor			GR-95

In addition to the Resistors, the following parts will be required:

- 1—R.F. choke (Part No. SA-157)
- 2— $\frac{1}{4}$ -in. self-tapping screws
- 1—2-lug terminal strip with mounting bracket serving as one of the lugs (Part No. FM-378)
- 1—Length of varnished tubing
- 1— $2\frac{1}{2}$ -in. 8-32 R.H. machine screw
- 1—8-32 nut
- 1—Lock washer for above
- 2— $\frac{5}{8}$ -in. fibre washers

As indicated above, the first color is the principal color of the main body of the resistor. The second color is that of the end of the resistor. The third color is that of the band around the resistor.

On ³ Assembly Stage Drawing No. 4, each resistor is designated by one or more letters, such as "A" or "BB". If resistor A is specified, for example, look up A on the Resistor Chart, where you will find the drawing of the actual mechanical size of the resistor at the head of the list, and the corresponding colors, which are Brown body color, Black end color, and Green band color.

You will also note that the smallest resistors are indicated by single letters, the medium-size resistors by two letters such as "BB", and the large-size resistors by three letters such

³ Furnished separately with this book.

as "CCC". On the two vitreous-coated resistors you will find the Part Numbers referred to in the Step-by-Step Instructions.

- NOTE: Before soldering the connections for any Resistors, measure the leads carefully, and cut them off as short as possible, making sure that both the wires and the Resistors are free and clear of all other parts and terminals. NOTE: Be careful not to heat the Resistors excessively when soldering. Do not in any case, make the leads less than $\frac{1}{2}$ -in. long. Shorter leads carry so much heat to the condensers that the terminals inside may come unsoldered. In some cases, the Resistor leads must be insulated with short lengths of varnished tubing, as called for in the Instructions which follow.
- Connect Resistor AAA from 6 on Socket A to 2 on Terminal Strip M.
- Connect Resistor AAA from 3 on Socket A to 1 on Terminal Strip M.
- Connect Resistor C from 4 on Socket A to Lug A.
- Connect Resistor T from 1 on Terminal Strip M to 2 on Terminal Strip M.
- Connect Resistor W from 1 on Terminal Strip AA to 8 on Socket A.
- Connect Resistor M from 1 on Terminal Strip AA to 2 on Terminal Strip AA.
- Connect Resistor K from 8 on Socket B to Lug B.
- Connect Resistor D from 3 on Socket B to 3 on Terminal Strip I.
- Connect Resistor M from 4 on Socket B to 2 on Terminal Strip AB.
- Connect Resistor I from 1 on Terminal Strip AB to 2 on Terminal Strip AB.
- Connect Resistor A from 6 on Socket B to 1 on Terminal Strip I.
- Connect Resistor D from 1 on Terminal Strip I to 3 on Terminal Strip I.
- Connect Resistor K from 8 on Socket C to 2 on Terminal Strip B.
- Connect Resistor D from 2 on Terminal Strip B to 3 on Terminal Strip J.
- Connect Resistor B from 3 on Terminal Strip J to 4 on Socket C.
- Connect Resistor I from 6 on Socket C to 3 on Terminal Strip C.
- Connect Resistor D from 1 on Terminal Strip J to 2 on Terminal Strip J.
- Connect Resistor J from 3 on Socket C to 2 on Terminal Strip J.
- Connect Resistor M from 1 on Terminal Strip C to 2 on Terminal Strip C.
- Connect Resistor M from 1 on Socket D to 4 on Socket D.
- Connect Resistor K from 2 on Socket D to 1 on R.F. Choke A.
- Connect Resistor AA from 6 on Socket D to 1 on Terminal Strip K.
- Connect Resistor B from 8 on Socket D to 4 on Terminal Strip K.
- Connect Resistor O from 2 on Terminal Strip K to 3 on Terminal Strip K.
- Connect Resistor DD from 1 on Terminal Strip K to 4 on Terminal Strip K.
- Connect Resistor A from 4 on Socket E to 1 on R.F. Choke A.
- Connect Resistor L from 8 on Socket E to 2 on R.F. Choke B.
- Connect Resistor M from 5 on Socket F to 1 on Terminal Strip Y.
- Mount R.F. Choke E (Part No. SA-157) on the underside of the chassis, using a $\frac{3}{4}$ -in. self-tapping screw.
- Mount Resistor EEE (Part No. GR-95) on the side of the chassis, as shown in the Drawing. Put a $2\frac{1}{2}$ -in. 8-32 R.H. machine screw through the chassis, with a $\frac{5}{8}$ -in. fibre washer on the screw. Then put the Resistor on the screw, another $\frac{5}{8}$ -in. fibre washer, a lock washer, and then a 8-32 nut. Tighten the nut firmly, but do not force it.
- Connect 1 on R.F. Choke E to 2 on Terminal Strip P (red wire).

FIG. 55. FIVE SIZES OF RESISTORS ARE USED IN THE ANDREA RECEIVER, AS SHOWN HERE. THE THREE SMALLER SIZES ARE COLOR-CODED, AS INDICATED IN THE DRAWINGS AND TABLES

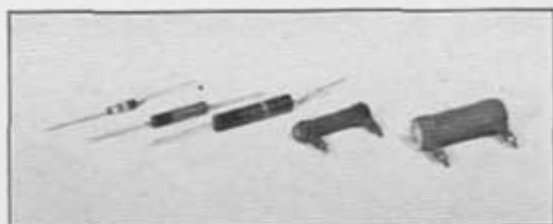

ON PAGE 66. THESE ARE NON-INDUCTIVE TYPES OF SPECIAL DESIGN, AND SUBSTITUTIONS MUST NOT BE MADE UNDER ANY CIRCUMSTANCES, OR TROUBLE WILL RESULT.

- Connect 1 (red dot) on R.F. Choke E to 1 on Filter Condenser D, (red wire). Keep this wire in the bend of the chassis.
- Connect Resistor AA from 1 on R.F. Choke E to 4 on Socket F.
- Connect 1 on Resistor DDD (Part No. GR-94) to 2 on R.F. Choke D (bare tinned wire).
- Connect 2 on Resistor DDD to 2 on R.F. Choke E (bare tinned wire).
- Connect 1 on Resistor EEE to 1 on Filter Condenser D (bare tinned wire with varnished tubing).
- Connect Resistor D from 2 on Resistor EEE to 1 on Terminal Strip Z.
- Connect 2 on Resistor EEE to 1 on Filter Condenser C (red wire).
- Connect Resistor AAA from 3 on Socket G to 1 on Terminal Strip L.
- Connect Resistor Q from 4 on Socket G to 3 on the Horizontal Hold Control.
- Connect 4 on Socket G to 1 on Terminal Strip C (bare tinned wire with varnished tubing).
- Connect Resistor M from 5 on Socket G to 1 on Terminal Strip C.
- Connect Resistor CCC from 6 on Socket G to 3 on Terminal Strip L.
- Connect Resistor T from 1 on Terminal Strip L to 3 on Terminal Strip L.
- Connect Resistor V from 6 on Terminal Strip E to 2 on the Horizontal Hold Control.
- Connect Resistor I from 2 on the Picture Width Control to 3 on the Horizontal Hold Control.
- Connect Resistor I from 1 on the Picture Height Control to 2 on the Vertical Hold Control.
- Connect Resistor EE from 2 on Socket H to 8 on Socket H.
- Connect Resistor M from 2 on Socket I to 3 on Terminal Strip H.
- Connect Resistor P from 6 on Socket I to 1 on Terminal Strip H.
- Connect the Bias Cell from 3 on Terminal Strip H to 2 on Terminal Strip H. NOTE: The end of the Bias Cell holder with the black dot must be connected to 3 on Terminal Strip H. Also, make sure that the Bias Cell is put into the holder so that the smaller end is adjacent to the black dot. If the Bias Cell is reversed, the receiver will not operate properly. Do not heat the Bias Cell excessively when making the connections to Terminal Strip H.
- Mount Terminal Strip AC on the underside of the chassis, using a 1/4-in. self-tapping screw. This is a 2-lug Terminal Strip with the mounting bracket on the end lug.
- Connect 1 on Socket J to 2 on Terminal Strip AC (bare, tinned wire).
- Connect Resistor I from 4 on Socket J to 1 on Terminal Strip AC. NOTE: Keep the leads short, and in a straight line.
- Connect Resistor F from 5 on Socket J to 2 on Terminal Strip AC.
- Connect Resistor CC from 6 on Socket J to 2 on Terminal Strip V.
- Connect Resistor O from 1 on Terminal Strip V to 2 on Terminal Strip V.

FIG. 56. TOP, THE SAFETY CAP AND LEAD, TESTED AT 6,000 VOLTS, FOR THE HIGH-VOLTAGE RECTIFIER TUBE. NEXT BELOW, GRID CAP AND SHIELDED LEADS FOR THE 6F8G TUBES.

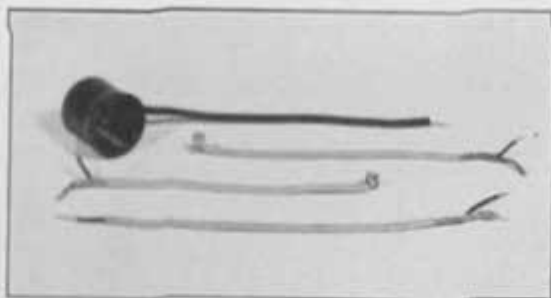

BOTTOM, SHIELDED LEAD CONNECTING THE TONE CONTROL TO SOCKET H. THESE PARTS ARE CALLED FOR IN ASSEMBLY STAGES 1 AND 3.

- Connect Resistor H from 1 on Trimmer Condenser D to 2 on Trimmer Condenser D. NOTE: Put this Resistor directly on top of Trimmer Condenser D, and make the leads as short as possible.
- Connect Resistor B from 1 on the Sound I.F. Transformer to 2 on the Sound I.F. Transformer.
- Connect Resistor G from 3 on the Sound I.F. Transformer to 1 on Terminal Strip T.
- Connect Resistor J from 3 on the Sound I.F. Transformer to 2 on Terminal Strip T.
- Connect Resistor Y from 2 on Terminal Strip T to 3 on Terminal Strip T.
- Connect 1 on Terminal Strip T to 1 on Terminal Strip AC (black wire).
- Connect Resistor U from 5 on Socket K to 1 on Terminal Strip U.
- Connect Resistor E from 1 on Terminal Strip U to 2 on Terminal Strip U.
- Connect Resistor F from 5 on Socket L to Lug E.
- Connect Resistor O from 2 on Terminal Strip P to 3 on Terminal Strip P.
- Connect Resistor CC from 1 on Terminal Strip P to 3 on Terminal Strip P.
- Connect Resistor I from 1 on Socket N to 1 on Terminal Strip N.
- Connect Resistor M from 1 on Terminal Strip N to 4 on Terminal Strip D.
- Connect Resistor I from 1 on Terminal Strip N to 1 on Terminal Strip O.
- Connect Resistor X from 1 on Terminal Strip N to 3 on Terminal Strip D.
- Connect Resistor BB from 5 on Terminal Strip O to 3 on Terminal Strip F.
- Connect Resistor BB from 4 on Terminal Strip O to 3 on Terminal Strip F.
- Connect Resistor BB from 3 on Terminal Strip O to 2 on Terminal Strip F.
- Connect 2 on Terminal Strip F to 2 on Terminal Strip O (H.V. yellow wire).
- Connect Resistor BB from 2 on Terminal Strip O to 1 on Terminal Strip F.
- Connect Resistor BB from 1 on Terminal Strip O to 1 on Terminal Strip F.
- Connect Resistor M from 1 on Terminal Strip D to 2 on the Horizontal Centering Control. NOTE: Slip pieces of varnished tubing over the leads from this Resistor to insulate them from the cover on the Picture Width Control.
- Connect Resistor X from 2 on Terminal Strip D to 2 on the Vertical Centering Control. NOTE: Slip pieces of varnished tubing over the leads from this Resistor.
- Connect Resistor D from 1 on the Brightness Control to the soldering lug at the corner of the steel base plate of the R.F. Unit.
- Connect Resistor P from 2 on the Focus Control to 1 on Terminal Strip W. NOTE: Slip pieces of varnished tubing over the leads from this Resistor.
- Connect Resistor O from 1 on Terminal Strip Q to 2 on Terminal Strip Q.
- Connect Resistor CC from 1 on Terminal Strip Q to 3 on Terminal Strip Q.

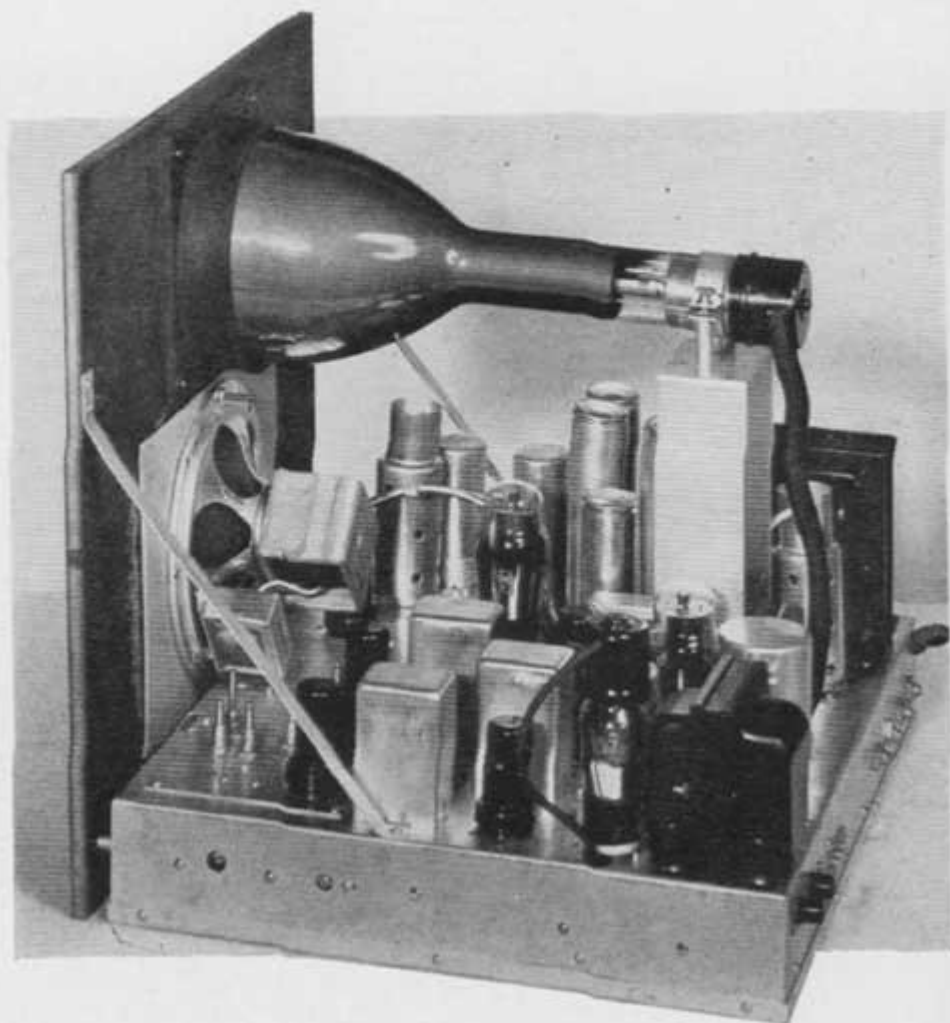

FIG. 57. COMPARING THE ASSEMBLY STAGE DRAWINGS WITH THE VIEWS OF THE ASSEMBLED CHASSIS WILL CLARIFY THE SUCCESSIVE CONSTRUCTION STEPS. NOTE THE HOLES IN THE SIDE OF THE CHASSIS, TOWARD THE FRONT, FOR ADJUSTING THE SOUND SENSITIVITY CONDENSER AND TRIMMER A.

- Connect Resistor BBB from 2 on Terminal Strip Q to 2 (red dot) on the Oscillator Coil of the R.F. Unit.

This completes Assembly Stage No. 4. **IMPORTANT:** Before proceeding further, check over every step in the preceding instructions to see that:

1. each connection is correct
2. every soldered joint is perfect
3. no loose pieces of wire or solder have dropped into chassis
4. you have not made any error in the color-coding of the resistors or their sizes
5. the position of the bias cell is exactly as shown in the drawing
6. all the resistor leads are clear of other parts and terminals

It is highly important, at this point, to inspect the work already done with the greatest thoroughness because, as you get into the mounting of the condensers, in the next Assembly Stage, it will be exceedingly difficult to locate errors in the connections and poorly soldered joints. By all means, have someone else double-check your work.

Do Not, Under Any Circumstances, Connect The Set To The Light Socket!

ASSEMBLY STAGE No. 5

Mounting and Wiring the By-pass Condensers

Assembly Stage No. 5 is concerned chiefly with the connections of the by-pass condensers. These are in a variety of sizes, determined by the capacity and voltage ratings. You will find the values stamped on each paper condenser, and indicated by colored dots on the molded mica condensers. The only exception is the tiny, round condenser with a white, ceramic covering, which is marked 10 MMF.

IMPORTANT: Each by-pass condenser is marked by a black ring at one end, indicating the lead attached to the outer foil. The condensers in the drawing are marked correspondingly. Make sure that the banded end of each condenser is connected as shown in the drawing.

NOTE: Many of the terminals to which you will solder the condenser leads have other wires soldered to them already. Be careful, when you solder the condenser leads, that you do not unsolder the other wires. Cut off the leads to make them as short as possible, but not less than $\frac{1}{2}$ in. long. Put the following parts together, for use in ¹ Assembly Stage No. 5:

- 4—Molded mica condensers, green and green-black-brown (Part No. HC-102)
- 1—Molded mica condenser, blue and brown-red-green (Part No. HC-169)
- 2—Molded mica condensers, orange and brown-black-red (Part No. HC-137)
- 1—White, ceramic-covered condenser 10MMF (Part No. HC-283)
- 3—.01 MFD.-200 V.D.C. (Part No. HC-9)
- 1—.05 MFD.-200 V.D.C. (Part No. HC-6)
- 1—.006 MFD.-1000 V.D.C. (Part No. HC-54)
- 13—.006 MFD.-600 V.D.C. (Part No. HC-60)
- 1—.25 MFD.-600 V.D.C. (Part No. HC-170)
- 6—.1 MFD.-600 V.D.C. (Part No. HC-171)
- 1—.025 MFD.-600 V.D.C. (Part No. HC-172)
- 1—.01 MFD.-600 V.D.C. (Part No. HC-173)
- 2—.001 MFD.-2500 V.D.C. (Part No. HC-174)
- 2—.25 MFD.-100 V.D.C. (part No. HC-175)
- 2—.002 MFD.-600 V.D.C. (Part No. HC-176)
- 1—.01 MFD.-1600 V.D.C. (Part No. HC-177)
- 1—10-25 electrolytic (Part No. HC-79)
- 2—Terminal strips, extra-long with 2 lugs and mounting bracket at the center (Part No. FM-618)
- 4— $\frac{1}{4}$ -in. self-tapping screws
- 2—Soldering lugs
- 1—Length of varnished tubing

- Connect a .1 MFD.-600 V.D.C. Condenser from Lug A to 3 on Terminal Strip I. Put a piece of varnished tubing on the latter lead.
- Connect a .25 MFD.-600 V.D.C. Condenser from 2 on Terminal Strip M to 2 on Terminal Strip AA. Keep this Condenser close to the chassis.
- Connect a .006 MFD.-600 V.D.C. Condenser from the soldering lug on the mounting bracket of Terminal Strip M to 2 on the Tone Control. Put a piece of varnished tubing on the latter lead.
- Connect a .01 MFD.-600 V.D.C. Condenser from 3 on Socket B to 5 on Socket B.
- Connect a .1 MFD.-600 V.D.C. Condenser from 6 on Socket B to 2 on Terminal Strip Z. Put varnished tubing on both leads.

¹Diagram furnished separately with this book.

FIG. 58. LEFT, THE TINY CERAMIC CONDENSER OF 10 MMF. CENTER AND RIGHT, TWO SIZES OF MOLDED MICA CONDENSERS, CODED WITH

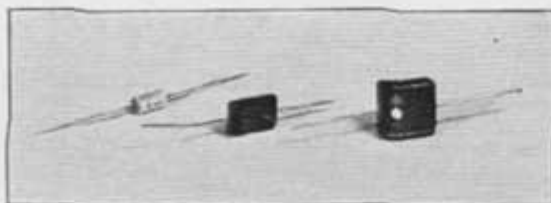

COLORS, AS INDICATED IN THE PARTS LIST AND ON ASSEMBLY STAGE DRAWING NO. 5. WATCH CLOSELY FOR THESE DOTS.

- Connect a .1 MFD.-600 V.D.C. Condenser from 6 on Socket B to 1 on Terminal Strip Z. Put a piece of varnished tubing on the lead to the Socket.
- Connect a .025 MFD.-600 V.D.C. Condenser from 2 on Terminal Strip AB to 1 on Terminal Strip Z.
- Connect a molded Mica Condenser from 4 on Socket B to 2 on Terminal Strip I. This Condenser has green and green-black-brown dots.
- Connect a molded Mica Condenser from 3 on Socket C to 3 on Terminal Strip B. This Condenser has orange and brown-black-red dots.
- Connect a molded Mica Condenser from 6 on Socket C to 2 on Terminal Strip B. This Condenser has green and green-black-brown dots.
- Connect a molded Mica Condenser from 6 on Socket C to 2 on Terminal Strip C. This Condenser has orange and brown-black-red dots.
- Connect a .002 MFD.-600 V.D.C. Condenser from 1 on Terminal Strip B to 4 on Terminal Strip K.
- Connect a .002 MFD.-600 V.D.C. Condenser from 3 on Terminal Strip J to 3 on Terminal Strip K. Put varnished tubing on both leads.
- Connect a .006 MFD.-600 V.D.C. Condenser from 2 on Terminal Strip J to 1 on Terminal Strip C.
- Connect a .01 MFD.-200 V.D.C. Condenser from 4 on Socket D to 2 (black dot) on R.F. Choke A. Put varnished tubing on both leads.
- Connect a molded Mica Condenser from 8 on Socket D to 3 on Terminal Strip K. This Condenser has blue and brown-red-green dots.
- Connect the white, ceramic-covered 10 MMF. Condenser from 4 on Socket E to the soldering lug on the mounting bracket of R.F. Choke B.
- Connect a .25 MFD.-100 V.D.C. Condenser from 4 on Socket E to 1 (red dot) on R.F. Choke A. This Condenser fits snugly against the R.F. Shield.
- Connect a .25 MFD.-100 V.D.C. Condenser from 2 on Terminal Strip Y to 2 on Terminal Strip X. NOTE: See that this Condenser is at least $\frac{1}{2}$ -in. from the underside of the chassis.
- Mount Terminal Strip AD on the underside of the chassis, using a $\frac{1}{4}$ -in. self-tapping screw. This is a long Terminal Strip with lugs only at the ends, and a mounting bracket at the center.
- Mount Terminal Strip AE on the underside of the chassis, using a $\frac{1}{4}$ -in. self-tapping screw. This is a long Terminal Strip with lugs only at the ends, and a mounting bracket at the center.
- Connect the braided leads of a .001 MFD.-2500 V.D.C. Condenser to 1 and 2 of Terminal Strip AD.
- Connect the braided leads of a .001 MFD.-2500 V.D.C. Condenser to 1 and 2 of Terminal Strip AE.

FIG. 59. VARIOUS TYPES AND SIZES OF BY-PASS CONDENSERS REQUIRED IN ASSEMBLY STAGE NO. 5. NOTE THAT EACH CONDENSER HAS A BLACK BAND AT ONE

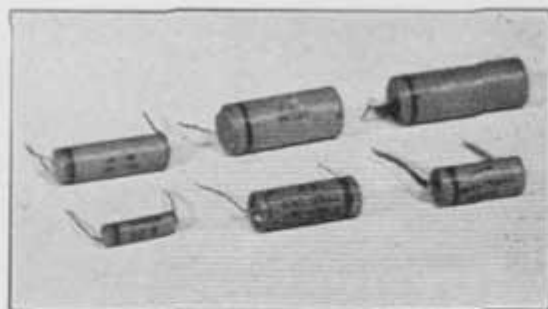

END WHICH MUST BE CONNECTED IN ACCORDANCE WITH THE POSITIONS INDICATED IN THE DIAGRAM. DO NOT OVERLOOK THIS, AS IT IS IMPORTANT.

- NOTE: Twist the two following leads together. Do not run them separately.
- Connect 1 on Terminal Strip AD to 1 on Terminal Strip D (H.V. green wire).
- Connect 1 on Terminal Strip AE to 4 on Terminal Strip D (H.V. green and white wire).
- Connect 2 on Terminal Strip AD to 6 on Socket G (blue wire).
- Connect 2 on Terminal Strip AE to 3 on Socket G (blue wire).
- Connect a .1 MFD.-600 V.D.C. Condenser from 6 on Socket D to 1 on Terminal Strip Y. Put varnished tubing on both leads.
- Connect a .1 MFD.-600 V.D.C. Condenser from 2 on Terminal Strip K to 4 on Terminal Strip E. Put a piece of varnished tubing over the latter lead.
- Connect a .006 MFD.-600 V.D.C. Condenser from 5 on Socket G to 1 on Terminal Strip L.
- Fasten Lug H to the underside of the chassis, using a 1/4-in. self-tapping screw.
- Connect the 10-25 Condenser (Part No. HC-79) from 8 on Socket H to Lug H. NOTE: This Condenser is marked + at one end. The + lead must be connected to the Socket. Put a piece of varnished tubing on the lead to the Socket.
- Connect a .006 MFD.-1000 V.D.C. Condenser from 3 on Socket H to Lug H. Put a piece of varnished tubing over the lead to the Socket.
- Connect a .1 MFD.-600 V.D.C. Condenser from 5 on Socket H to 6 on Socket L.
- Connect a .01 MFD.-200 V.D.C. Condenser from 5 on the Volume Control & Switch to 2 on Terminal Strip T. Put varnished tubing on both leads. Keep this Condenser close to the front of the chassis.
- Connect a .01 MFD.-200 V.D.C. Condenser from 2 on Socket I to 4 on the Volume Control & Switch. Put varnished tubing on both leads.
- Connect a molded Mica Condenser from 4 on Socket J to 5 on L.F. Transformer C. This Condenser has green and green-black-brown dots. NOTE: See that this condenser is flat against the chassis.
- Connect a .006 MFD.-600 V.D.C. Condenser from 5 on Socket J to Lug F. NOTE: Keep the leads as short as possible, and locate the Condenser directly against the R.F. Shield.
- Connect a .006 MFD.-600 V.D.C. Condenser from 6 on Socket J to the soldering lug on the R.F. Shield. NOTE: Keep the leads as short as possible, and locate the Condenser directly against the R.F. Shield.

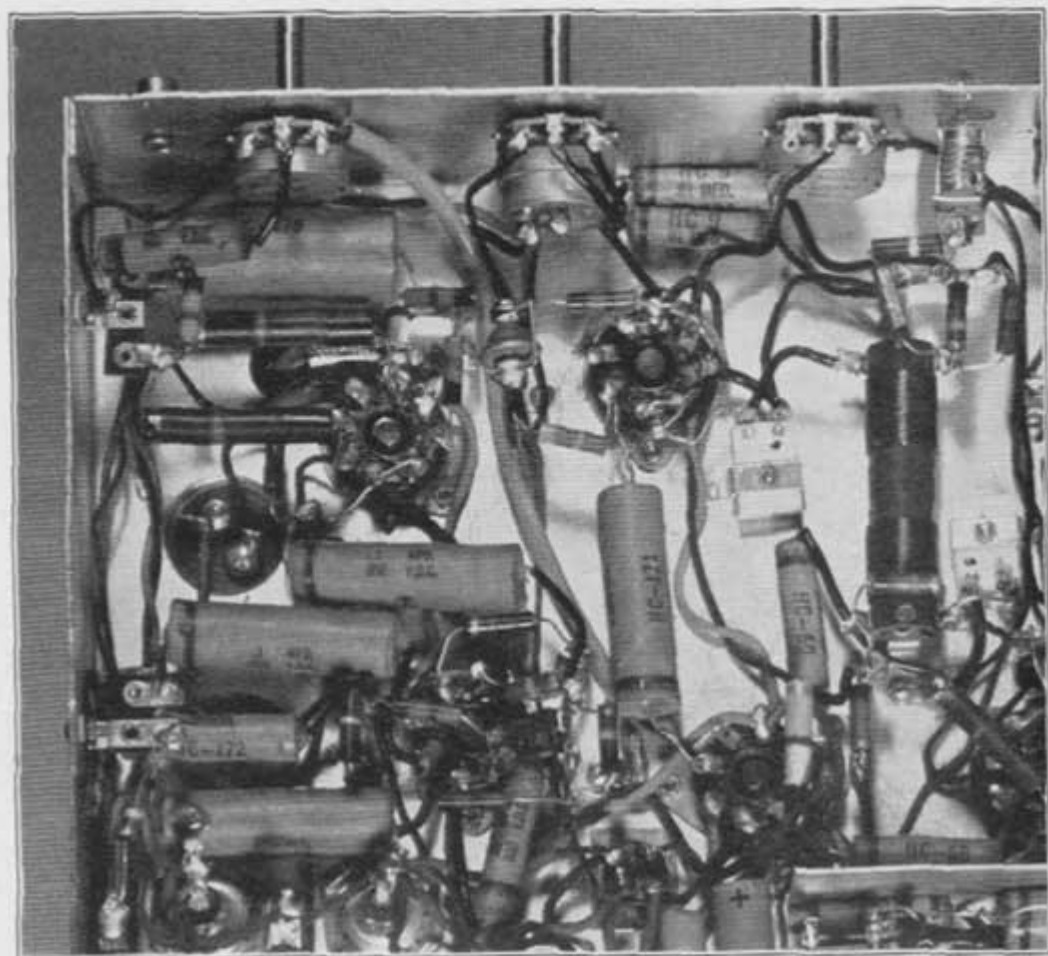

FIG. 60. UNDER SIDE OF THE CHASSIS, CORRESPONDING TO THE UPPER LEFT HAND QUARTER OF THE DRAWINGS. COMPARE THE WIRING AND THE POSITIONS OF THE PARTS WITH YOUR OWN ASSEMBLY AND WIRING. NOTE PARTICULARLY THE POSITION OF THE BIAS CELL.

- Connect a .006 MFD.-600 V.D.C. Condenser from 2 on Terminal Strip V to the soldering lug on the mounting bracket of the Sound I.F. Transformer. Put varnished tubing on both leads.
- Fasten Lug I to the underside of the chassis, using a $\frac{1}{4}$ -in. self-tapping screw.
- Connect a .05 MFD.-200 V.D.C. Condenser from 1 on Terminal Strip AC to Lug I.
- Connect a molded Mica Condenser from 3 on the Sound I.F. Transformer to 3 on Terminal Strip T. This Condenser has green and green-black-brown dots.
- Connect a .006 MFD.-600 V.D.C. Condenser from 6 on Socket K to Lug C. Put a piece of varnished tubing on the lead to the socket. NOTE: This Condenser must go underneath the lead from 1 on I.F. Transformer B to 8 on Socket K.
- Connect a .006 MFD.-600 V.D.C. Condenser from Lug C to 1 on Terminal Strip U. Put a piece of varnished tubing on the latter lead.
- Connect a .006 MFD.-600 V.D.C. Condenser from Lug F to 2 (red dot) on I.F. Transformer C. Put a piece of varnished tubing on the latter lead.
- Connect a .006 MFD.-600 V.D.C. Condenser from 5 on Socket L to Lug E. Put a piece of varnished tubing on the lead to the Socket.

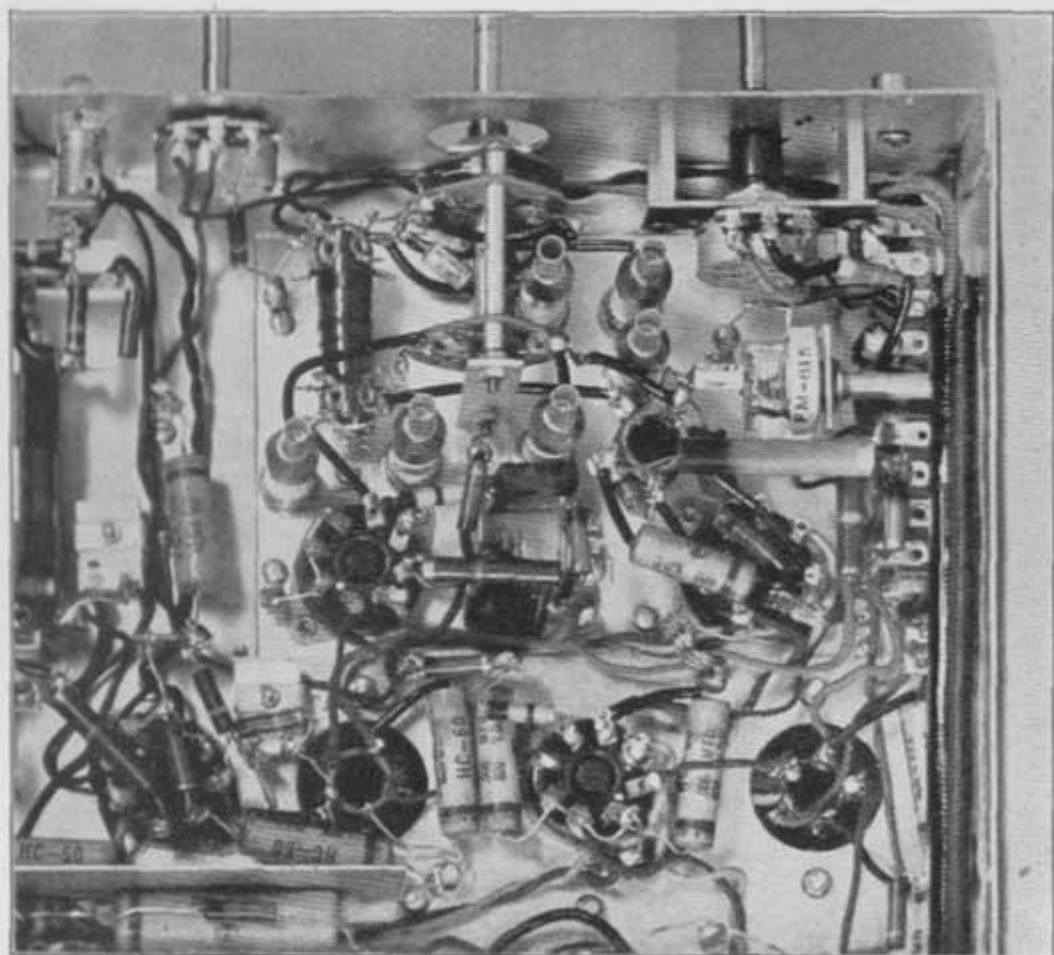

FIG. 61. UPPER RIGHT HAND SECTION OF THE COMPLETED RECEIVER. SEE HOW THE CONDENSERS ARE PLACED WITH RELATION TO THE SHIELD. THE LEADS FROM THE CONDENSERS AND RESISTORS ARE SHORT, YET LONG ENOUGH TO PREVENT EXCESSIVE HEATING WHEN THEY ARE SOLDERED.

- Connect a .006 MFD.-600 V.D.C. Condenser from 6 on Socket L to 6 on Terminal Strip D.
- Connect a .006 MFD.-600 V.D.C. Condenser from 2 (red dot) on I.F. Transformer B to Lug E. Put a piece of varnished tubing on the lead to the I.F. Transformer.
- Connect a .006 MFD.-600 V.D.C. Condenser from 2 (red dot) on I.F. Transformer A to 3 on Filter Condenser G. Put a piece of varnished tubing on the lead to the I.F. Transformer.
- Connect a .01 MFD.-1600 V.D.C. Condenser from 1 on Terminal Strip W to the soldering lug on the mounting bracket of Terminal Strip Q. Put varnished tubing on both leads. This Condenser must be put under Terminal Strips Q and W, as shown in the Drawing.

This completes Assembly Stage No. 5. **IMPORTANT:** Before proceeding further, check over every step in the preceding instructions to see that:

1. the wiring is correct
2. every soldered joint is perfect

3. the capacity and voltage ratings of each condenser are correct
4. the polarity is right for the 10-25 condenser
5. the banded end of each condenser is connected as shown in the drawing
6. varnished tubing has been put on the leads where it is specified

Be sure to have someone else double-check your work, for this is your last opportunity to catch and correct any mistakes!

Do Not, Under Any Circumstances, Connect The Set To The Light Socket!

ASSEMBLY STAGE No. 6

Final construction steps, adjustments, and instructions

The following parts are required to complete the assembly of this Television Receiver:

- 1—Steel safety plate
- 2— $\frac{1}{2}$ -in. front panel mounting studs
- 1— $\frac{3}{4}$ -in. 6-32 F.H. machine screw
- 1—Steel bottom plate
- 2— $1\frac{3}{4}$ -in. posts for holding tube mounting clamps
- 2—Picture tube clamps
- 18— $\frac{1}{4}$ -in. self-tapping screws
- 2— $\frac{1}{4}$ -in. thin, flat head 6-32 machine screws
- 1—6-32 nut
- 5—lock washers for above
- 4—8-32 nuts
- 4—lock washers for above
- 2— $\frac{5}{16}$ -in. 6-32 R.H. machine screws
- 2—Knurled thumb nuts
- 1—Glass window
- 1—Front panel
- 1—Soft rubber mask
- 4— $\frac{1}{2}$ -in. blued wood screws
- 4— $\frac{3}{4}$ -in. fibre washers
- 1—Glass bull's eye
- 1—Loudspeaker
- 2—1-in. 8-32 decorated-head machine screws
- 2— $\frac{1}{2}$ in. 6-32 oxide finish thin, flat head machine screws
- 2—Front panel supporting brackets
- 4— $\frac{3}{8}$ -in. R.H. wood screws
- 5—Control knobs
- 1—Control knob with white dot
- 16—Vacuum tubes
- 2—Tube shields
- 1—Picture tube

- Mount the steel Safety Plate at the rear, right hand corner of the chassis, using three $\frac{1}{4}$ -in. self-tapping screws through the side of the chassis. This plate covers the high-voltage terminals under the chassis, and must be kept in place for YOUR PROTECTION!
- Fasten a $\frac{1}{2}$ -in. stud at each side of the front of the chassis. These are used to space the front panel back from the front of the chassis. Use two $\frac{1}{4}$ -in. 6-32 machine screws with thin, flat heads, and put a lock washer under the head of each screw.
- Put the $\frac{3}{4}$ -in. 6-32 F.H. screw through the countersunk hole in the bottom plate. Fasten it with a lock washer and nut. This screw closes the Safety Switch when the bottom plate is put in place.

FINAL INSPECTION: Experience with the mistakes of set builders shows that the most frequent errors are in the connections to the sockets. At this point, go over each socket, and compare the wiring with the five diagrams. You are very liable to find that you have made connections to one of the unused contacts. Such an error will, of course, render the set inoperative!

- Put the bottom plate on the chassis, fastening it with ten $\frac{1}{4}$ -in. self-tapping screws. NOTE: Do not put in the three screws at the front of the chassis at this time. Wait until all the testing and checking are finished, because these three screws cannot be removed without taking off the front panel.
- Fasten the two $1\frac{3}{4}$ -in. posts on the Tube Mounting Bracket. These posts carry the clamps which hold the Picture Tube. Use two $\frac{5}{16}$ in. 6-32 R.H. machine screws and lock washers. The posts should be fastened to the middle holes on the top of the Tube Mounting Bracket.
- Put the lower Picture Tube clamp on the threaded studs of the posts, and fasten it with an 8-32 nut and lock washer on each side.
- Put the upper Picture Tube clamp on the threaded studs of the posts, and fasten it on each side with a knurled thumb nut.
- Put the front panel flat on your workbench, front side down, and put the glass window over the Picture Tube opening.
- Four holes are already spotted on the rear of the front panel for the screws to fasten the soft rubber mask which frames the pictures and serves as a shock-absorbing mounting for the front of the Picture Tube. Put the mask in place over the glass, and fasten it to the front panel with four $\frac{1}{2}$ -in. blue R.H. wood screws, with a $\frac{3}{4}$ -in. fibre washer under the head of each screw.
- Push the glass bull's eye for the Pilot Light into the hole at the bottom of the front panel.
- Fasten the Loudspeaker to the front panel, using two 1-in. decorated-head 8-32 machine screws. Looking at the front panel from the rear, the Loudspeaker should be mounted so that the Output Transformer is in line with the lower left hand corner of the front panel.
- Put 8-32 nuts and lock washers on the two screws which hold the Loudspeaker in place.
- Fasten the front panel to the two studs on the front of the chassis, using two $\frac{1}{2}$ -in. 6-32 machine screws with copper-oxide finished, thin flat heads.
- Fasten the two front panel supporting brackets to the chassis with $\frac{1}{4}$ -in. self-tapping screws, and to the front panel with four $\frac{3}{8}$ -in. R.H. brass wood screws. NOTE: Before tightening the screws in the chassis, adjust the front panel so that it is perpendicular. Then tighten the screws.

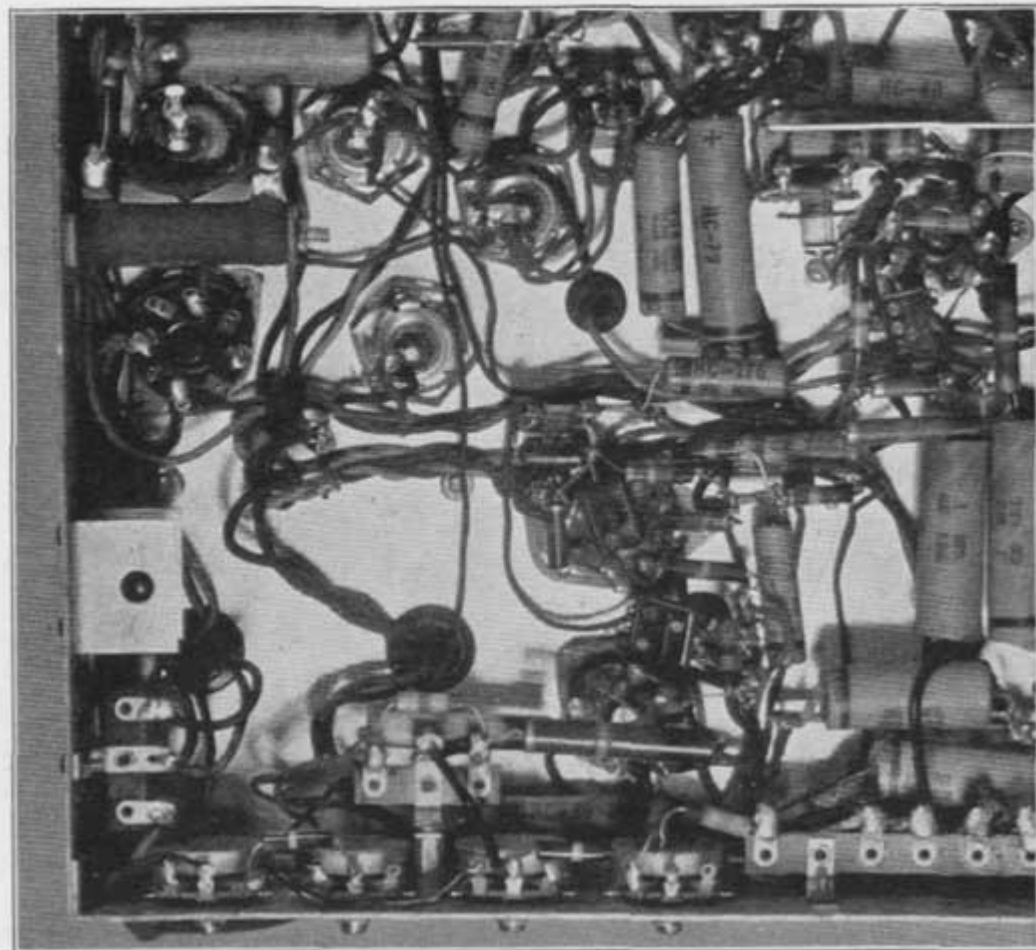

FIG. 62. LOWER LEFT HAND SECTION OF THE FINISHED CHASSIS. IF ANY POINT OF THE ASSEMBLY INSTRUCTIONS IS NOT CLEAR, CHECK IT WITH THESE FOUR CLOSE-UP VIEWS, FIGS. 60, 61, 62, AND 63. SEE HOW THE LARGE RESISTOR AND THE SAFETY SWITCH ARE MOUNTED AT THE LEFT.

- Put the six knobs on the front controls. One knob has a white dot. This knob belongs on the Channel Selector Switch. Tighten the set screws firmly.
- Insert the Speaker Plug in the Speaker Plug Socket on the chassis. See that the orange dot on the Speaker Plug coincides with the orange dot on the Speaker Plug Socket.
- Insert the tubes in the Sockets. The number of each tube is stamped on each Socket. The tube complement is also shown in Fig. 71.
- Put the two tube shields in place, and put on the tube caps, making sure that the leads are clear of the shields.
- Put the large, insulated cap on the High Voltage Rectifier Tube.
- Mount the Picture Tube by pressing it into the soft rubber mask at the front, and secure it at the rear with the clamps on the Picture Tube mounting bracket. See that the tube is pressed all the way to the front of the opening in the mask. NOTE: The key on the center pin of the tube base should be at the left, when you are facing the rear of the chassis.
- Put the Picture Tube Socket on the base of the Picture Tube.

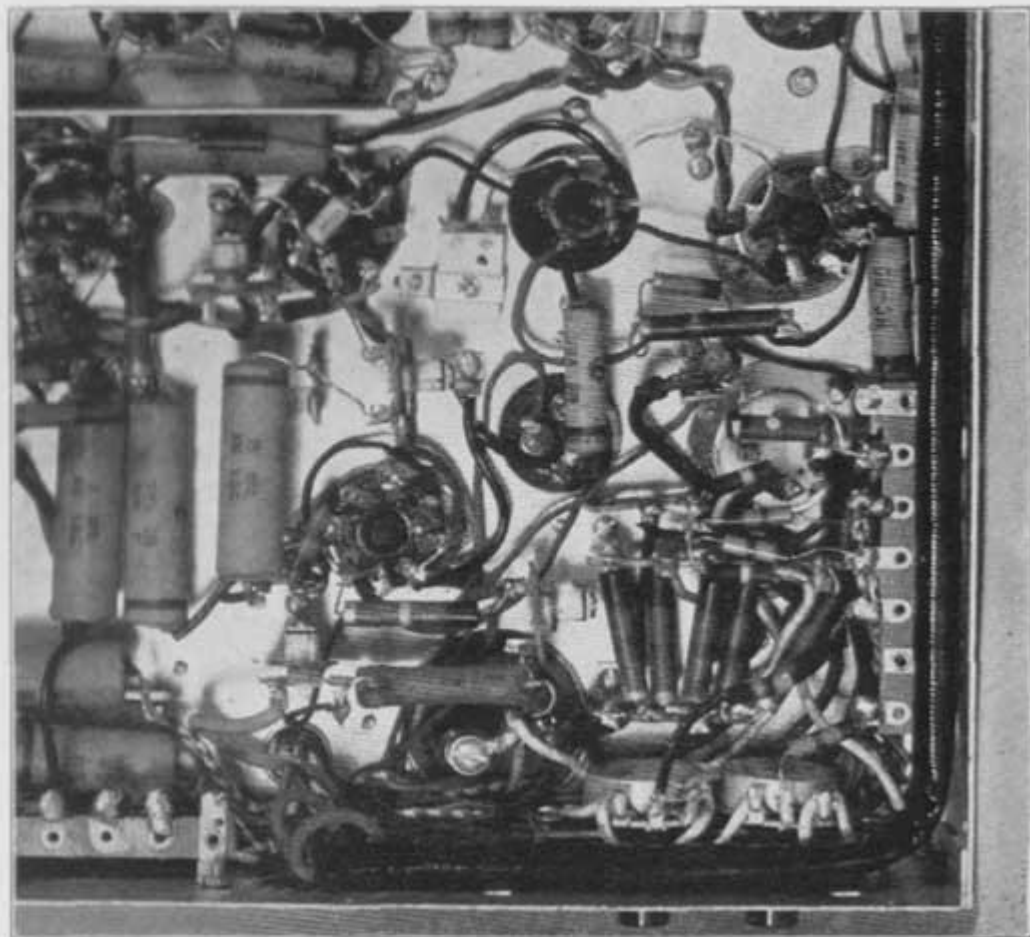

FIG. 63. DO NOT BE CONFUSED BY THE CLOSE GROUPING OF THE RESISTORS IN THE LOWER RIGHT HAND SECTION OF THE CHASSIS. USE THE GREATEST CARE WHEN YOU SOLDER THE LEADS, SO THAT THE RESISTORS WILL NOT BE DAMAGED BY EXCESSIVE HEAT FROM THE SOLDERING IRON.

ADJUSTING THE SET: The final adjustments of your television receiver must be made during hours when there is a program on the air. Since the Teleceptor may introduce complications if it is not already oriented, it is advisable to take your set to the home of a friend who has a set in operation already, so that you can use his Teleceptor. Then you will know that you are picking up adequate signals, free from ghosts.

If that is not practical, you may be able to borrow a receiver so as to check your own Teleceptor. That will eliminate one unknown quantity. Otherwise, you will have to do the best job you can of erecting your Teleceptor in accordance with the information given in Chapter V. When you get some kind of an image on your set, you can check the orientation of the Teleceptor, and make further adjustments on the set until, working back and forth, you have the complete system at peak efficiency.

IMPORTANT: Do not alter the adjustment of the plunger condensers on the R.F. Tuning Unit or the Sound Sensitivity Variable Condenser, nor make any change in the wiring of this Unit. The controls have been set accurately at the Andrea factory.

In case the Sound Sensitivity Condenser has been turned, set the shaft so that exactly one-half of the variable plate is interleaved with the fixed plates. If any of the plunger condensers has been changed, it will be necessary to go through the R.F. alignment instructions given in Chapter VII.

CONNECT THE ANTENNA & GROUND: With your Teleceptor antenna installed in accordance with the instructions which accompany it, connect the twisted-pair lead-in to the A,A terminals at the rear of the chassis. **NOTE:** Do not neglect the ground connection, as this is highly important for television reception. The G terminal at the rear of the chassis must be connected to a good ground, such as a radiator or water pipe. The connection should be made with an **INSULATED** wire, as short as possible.

BEFORE TURNING ON THE POWER: Before you plug in the line cord, make a final check to see that all the tubes are in their proper places, that the picture tube is firmly in place and that the socket is pushed on firmly, that the shields are in place, the grid caps pushed down tightly, and that the speaker plug is in its socket.

WARNING: When you switch on the current, if the pilot light does not light immediately, or if you hear a humming sound from the power transformer, turn off the set **AT ONCE**. This would mean that something is probably wrong in the wiring of the filament circuits.

THE RASSTER: When you switch on your set, there will probably be some kind of illumination or rasster, on the screen. If not, put the Contrast Control at about the center, and turn up the Brightness Control until the screen is lighted. If there is no illumination, switch off the current, and check the picture tube socket, to see that it is pushed on firmly. If there is still no "rasster" on the tube, refer to the Trouble Shooting Chart in Chapter VII.

KEEP BRIGHTNESS DOWN: The life of the picture tube is determined by the fluorescent screen. The filament and the control elements will last several thousand hours. However, you can burn the screen very quickly by running the tube at excessive brightness.

SQUARING THE TUBE: The horizontal lines of the rasster must be parallel with the top and bottom of the rubber mask. You will probably have to turn it one way or the other. When you do this, switch off the current, loosen the rear tube clamp, and turn the tube by grasping it at the front.

Be sure to turn off the current first! If you touch the glass part of the tube and any part of the chassis while the current is on, you will get a static shock through the glass. It will not shock you severely, but it will startle you, and make you jerk your hand back.

RETURN TRACES: At times when there is no program, you will see white, slanting lines on the rasster. This is perfectly normal, for they are retrace lines which are blanked out when the transmitter impulses are being received. Also, when no signals are being received, the vertical edges of the rasster form lines which waver slightly, but they become straight and steady as soon as reception starts.

CENTERING & SIZE CONTROLS: The rasster will not be centered when you first turn on the set. Accordingly, you must adjust the horizontal centering control, at the rear on the extreme right as you face the front of the set, and the adjacent vertical centering control. Next adjust the picture height control, at the extreme left, and the picture width control, third from the left, until the rasster is just inside the rubber mask.

HOLD CONTROLS: With a program on the air, you will see some kind of activity on the screen, even though it is not clear reception. Pictures may seem to be moving rapidly up or down on the screen, or you may see two or three pictures above each other. That requires adjustment of the vertical hold control, the second in from the left at the rear, as you face the front of the set.

Turn the control all the way in one direction. Then bring it back. The picture will move rapidly on the screen, slow down, break up, and move quickly again. As you continue to turn the control, however, you will reach a point where you will see a single picture moving slower and slower until it stops. Turning the control further will make the picture move again, but in the opposite direction.

Adjust the vertical hold control further until the picture is moving UPWARD slowly. Then turn the control just until the picture snaps into place. Do not get the final adjustment of the vertical hold control while the picture is moving downward!

If you cannot seem to hold the picture vertically, or if it seems to slip out of adjustment, increase the contrast control. This is actually the sensitivity control of the set. With too little signal, you will not get enough synchronizing impulse from the transmitter to hold the picture. In case you have the contrast control at maximum—all the way clockwise—and you cannot hold the picture, your antenna is not picking up sufficient signal, as explained in Chapter V.

RECHECKING THE CONTROLS: There is a degree of interrelation between the picture height and vertical hold controls, and between the picture width and horizontal hold controls. Consequently, after the preliminary adjustments, you should go over them again. Be sure that the picture is just inside—not outside—the opening in the mask. Get your final setting of the vertical hold when the contrast control is turned almost to the point where the pictures start to slip up from lack of adequate signal.

SHARPENING THE PICTURE: For clearest pictures, keep the brightness down, and turn up the contrast until you have normal contrast between the light and dark parts of the picture. Then adjust the focus control for maximum sharpness. This control regulates the size of the dot which forms the picture lines.

TRIMMER ADJUSTMENTS: At this point, you may have pictures without sound, due to the fact that the trimmer condensers have not been adjusted. Keep the volume control turned down while you adjust the trimmers, so as to get the most accurate settings.

There are five Trimmer Condensers on the chassis, four on the top and one on the right side, looking at the set from the front. In addition, there is a Sound Sensitivity Control, mounted on the R.F. Unit, at the right. These are shown in the accompanying illustration. At this point, Trimmers A, D, and E should be adjusted as follows:

Trimmer A— $\frac{3}{4}$ turn less than hand tight

Trimmer D— $\frac{1}{2}$ turn less than hand tight

Trimmer E— $\frac{3}{4}$ turn less than hand tight

First, turn the Trimmer adjusting screw all the way in, holding the screwdriver lightly between two fingers. This is called "hand tight." Do not grip the screwdriver, nor force the screw. Then, turn the screw back the amount specified above.

Trimmers A and E are used to prevent interference on one channel from transmission of the other channel. Trimmers B and C are sound channel trimmers. Trimmer D is a sound channel trimmer and also serves to keep the sound out of the picture.

FINAL TRIMMER ADJUSTMENTS: Adjust the B and C Trimmers until the loudest audio volume is obtained. If necessary, in order to get accurate adjustments, reduce the Volume Control again. It may help to readjust Trimmer D.

Your receiver should be adjusted and synchronized when these steps have been completed. Examine the picture for small, dark, horizontal bands. If such bands are visible, readjust Trimmer D. If this does not eliminate them, readjust Trimmers A and E.

SOUND SENSITIVITY CONTROL: When the set has been in use for some time, it may be advisable to check the Sound Sensitivity adjustment, marked SS on the illustration. Using a screwdriver, turn the condenser very slowly, tuning for the loudest audio signals. If the adjustment of the Sound Sensitivity Control affects the images, adjust the Sound Sensitivity for best image reception, and then readjust the Trimmers B and C for loudest audio volume.

REVERSE THE LINE PLUG: In some instances, an improvement in reception is obtained by reversing the line plug. Try this, to see if reversing the line plug in your home makes any difference in the clarity of the images received.

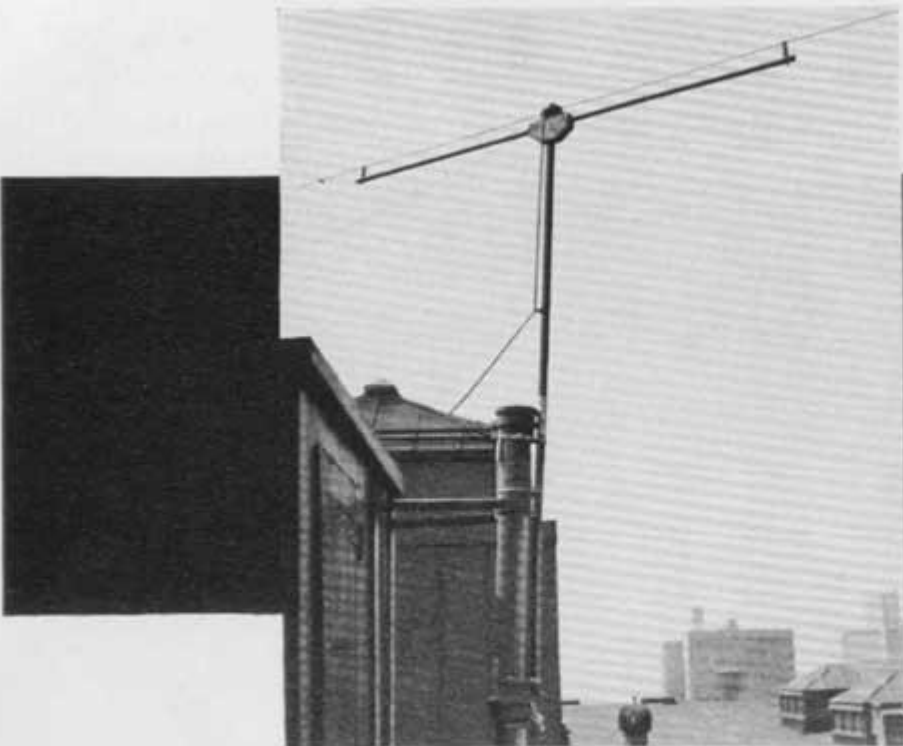

FIG. 64. E. L. BRAGDON, RADIO EDITOR OF THE NEW YORK SUN, ERECTED THIS ANDREA TELECEPTOR ON THE ROOF OF THE SUN BUILDING. HIS SATURDAY RADIO SECTION CONTAINS THE MOST COMPLETE REPORT OF TELEVISION ACTIVITIES AND PROGRESS OF ANY NEWSPAPER PUBLISHED IN THE U. S.

CHAPTER FIVE

How to Erect and Adjust a Television Antenna of Maximum Efficiency

Almost any antenna arrangement can be used for broadcast reception, ranging from a few feet of wire dropped on the floor, to vertical rods, and on to elaborate noise-reducing installations.

Such antennas are definitely ruled out for ultra-frequency television waves, however. Adequate pick-up at ultra frequencies requires a di-pole construction of such dimensions as to be tuned to the incoming signals. The tuning need not be sharp, but there is a decided loss of response if the antenna is not tuned within fairly narrow limits.

The Television Antenna: Fundamentally, the di-pole consists of a rod one-half wavelength long. The rod is cut apart at the center, and a twisted pair, with one wire joined to each half of the rod, is brought down to the receiving set.

Suppose, for example, you want to cover the 44 to 50 and 50 to 56 mc. channels. The

di-pole should be designed for the middle frequency of 50 mc. which is equivalent to a wavelength of 6 meters. Thus, the total length of the rods should be 3 meters, or $3 \times 3.28 \text{ ft.} = 9.84 \text{ ft.}$

Reflectors: Much has been said and written about the use of reflectors to increase the signal picked up by a di-pole antenna. Reports from concerns specializing in television installations confirm the writer's experience that the use of a reflector is seldom justified by any improvement in signal strength. A reflector is merely a solid rod, exactly as long as the total length of the di-pole rods mounted $\frac{1}{4}$ wavelength behind them.

This calls for heavy and elaborate construction, with a much heavier mast and anchorage. Such an arrangement is not as convenient to mount as a plain di-pole, and is awkward to adjust when the antenna is

being oriented. If added signal pick-up is required, the most effective method is to increase the height of the di-pole.

Line-of-Sight Reception: Theoretically, the television antenna must be mounted at a point where the transmitting antenna is

will be able to work out an arrangement that will give you sufficient signal strength.

The Teleceptor: The Andrea Teleceptor, illustrated in Fig. 65 is an improved type¹ of commercial di-pole. It has been adopted generally for use with all makes of television

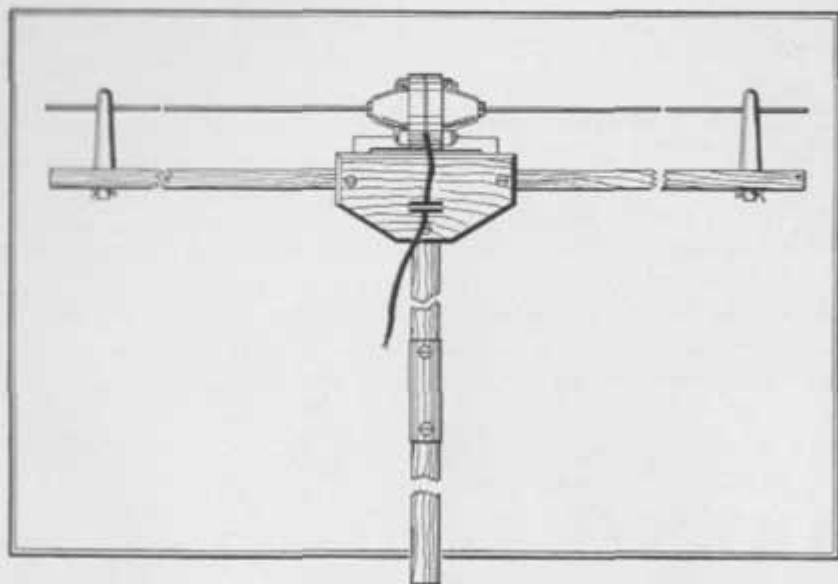

FIG. 65. DETAILED VIEW OF THE ANDREA TELECEPTOR AND MAST. THE HORIZONTAL ARMS PREVENT THE RODS FROM WHIPPING AROUND IN THE WIND. THE MAST IS IN TWO JOINTED SECTIONS, SO THAT THE LOWER PART CAN BE FASTENED DOWN, AND THE UPPER PART TURNED UNTIL THE BEST POSITION IS FOUND.

within line of sight. In practice, however, this is not necessary. Right in New York City, there are installations where the antenna is in the "shadow" of a taller building yet adequate pick-up is obtained. This may, of course, be due to the reflection of waves from another building. The important thing is that reception is possible.

Where the receiving antenna is behind a hill, reception may be poor right at the foot of the hill, but a mile farther from the transmitter, the signals will probably be strong again.

Since ultra-frequency waves do not follow the line-of-sight rules exactly, performance can be determined only by actual experience. In all probability, if you are within 40 to 50 miles of the New York stations, or if you are similarly located with reference to another station of comparable height and power, you

receivers because of its high efficiency, and the ease with which it can be erected and adjusted.

In fact, stores, hotels, apartment houses, and suburban homes in the areas around New York, Philadelphia and Los Angeles are beginning to sprout a crop of Teleceptors as if they had been sowed by the television waves. On the roof of one New York department store, there are six Teleceptors, used for demonstrating different sets in their television display.

The Teleceptor is mounted on an 8-ft. mast, jointed at the middle so that the lower section can be secured firmly, while the upper section can be rotated. A heavy wooden block carries a waterproof porcelain unit, with bushings into which the di-pole rods are

¹ Patent claims have been filed on special features.

threaded. The block also supports two wooden arms fitted with porcelain stand-off insulators to steady the rods.

Experience with actual reception shows that, in a strong wind, the rods may whip around enough to cause detuning which shows up in the pictures. This construction, without adding objectionable weight or wind resistance, keeps the rods steady under all conditions.

The construction of the coupling unit takes the strain off the lead-in cable, and protects the connections against corrosion. The cable is a 100-ohm twisted pair, covered with solid rubber. 75 ft. of cable are supplied with the Teleceptor, and additional 75-ft. coils are available if needed.

Glazed porcelain insulation for the di-pole rods is preferable to plain wooden supports. While wood is satisfactory for temporary construction, carbon soot deposits are retained by the wood, and layers are soaked in by the rain and baked by the sun until low-resistance paths are created which impair reception.

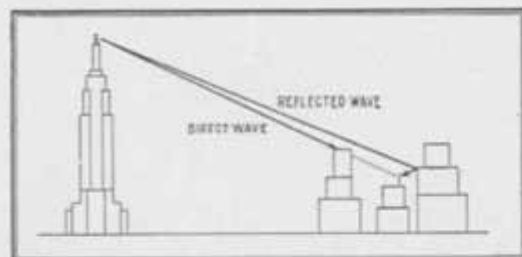

FIG. 67 WHEN THE DIRECT SIGNAL IS CUT OFF, REFLECTED WAVES MAY PROVIDE AN ADEQUATE SIGNAL TO THE TELECEPTOR.

All wooden parts of the Teleceptor are weatherproofed by creosote, so that, once set up, it will withstand all climatic changes indefinitely.

Length of the Rods: The Teleceptor rods are cut to the correct length for reception on 44 to 50 and 50 to 56 mc. However, if you are going to receive other bands, it is necessary to cut off the rods. Instructions supplied with the Teleceptor give the lengths for different channels, and combination of channels. Also, the rods are scored for cutting at the various lengths listed.

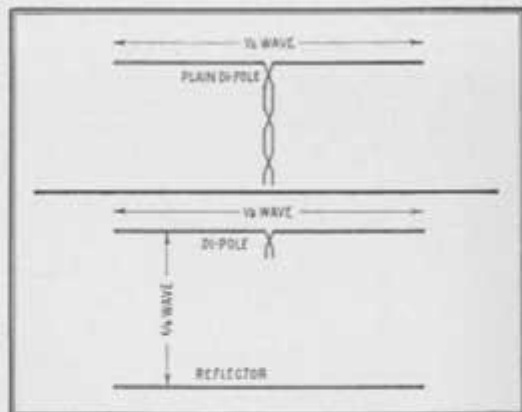

FIG. 66. ABOVE, A PLAIN DI-POLE, $\frac{1}{2}$ WAVELENGTH LONG. BELOW, A DI-POLE WITH A REFLECTOR, SPACED $\frac{1}{4}$ WAVELENGTH TO THE REAR.

Mounting the Teleceptor: Height is the vital factor of television antenna efficiency. The pick-up is only at the horizontal portion. Increasing the height of the Teleceptor not only increases the signal pick-up. It also removes the antenna from the source of automobile interference, if such interference is present. Consequently, raising the antenna serves two useful purposes.

The construction of the Teleceptor has been made extremely light so that the mast can be mounted easily, with a minimum of support. If you find it necessary to use guy wires, break them up every 2 ft. with insulators.

A standpipe on the roof generally offers the most convenient support. Two straps are furnished for this type of mounting. There are also clamps which can be secured to a chimney or a brick wall. Your own ingenuity will suggest ways to meet any unusual circumstances.

If your receiver is to be installed in a low building adjacent to one that is higher, try to put your antenna on the taller building. If you cannot do this, you may find it necessary to put up a pole, fastening the Teleceptor mast at the top.

Lead-in: The lead-in must be run to the set as directly as possible. Do not try to get reception with a coil of extra lead-in at the set. Cut it off. If you need to piece the lead, you must use exactly the same kind of cable throughout the entire length. This applies not only to the Teleceptor, but to any

type of antenna. Do not use different kinds of cable in your lead.

Orientation: With your antenna set up, you must swing or orient the horizontal rods until you get an adequate signal with minimum interference and ghosts. The line of maximum pick-up is at right angles to the di-pole rods. Pick-up is zero at the ends of the rods. Consequently, if you have a particular source of interference, as shown in Fig. 69, you may get the best results by pointing the rods at the interference source, even though the rods are not at exactly right angles to the line of reception.

Again, you may see reflections or ghosts, in your picture. These are caused by the reception of reflected waves. This is illustrated in Fig. 68. The first image is set up by the direct wave from the transmitter. The reflected wave, travelling a longer path, is delayed by only a fraction of a micro-second, yet that slight difference in time is sufficient to make a second image, slightly offset from the first.

Reflections can be eliminated by orienting the rods. This is a cut and try process, turning the mast and checking the resulting reception.

To facilitate this work, servicemen generally work in pairs, and provide themselves with intercommunicating telephones, so that the man at the set can instruct the man at the antenna. While this is not absolutely necessary, it saves a great deal of time.

Insufficient Pick-up: If your receiver does not hold its vertical synchronization, that is, if the pictures slip up either steadily or a frame at a time, the fault lies in the lack of adequate signal pick-up.

If you are troubled with static interference, and you have to put the contrast control at maximum to get any picture at all, your antenna is not picking up enough signal.

Again, if your pictures are grey and indistinct even though you put the contrast control at maximum, the fault lies in your antenna.

There are two ways to increase the signal delivered to your receiver. One is to in-

crease the pick-up by increasing the height at the di-pole. The other, in cases where the lead-in is over 75 ft. is to reduce the resistance of the lead by replacing the twisted pair with coaxial cable.

When signals are weak, your set may be getting enough to form a picture, but the synchronizing impulses may not be strong enough to hold the picture. Thus it will drift, no matter how carefully you adjust the

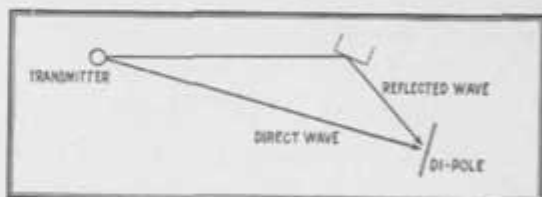

FIG. 68. GHOSTS OR DOUBLE IMAGES ARE CAUSED BY THE DELAYED RECEPTION OF REFLECTED SIGNALS.

vertical hold control, or the picture will slip a frame each time there is a slight static impulse. In fact, under such conditions, you may be able to make the picture slip by striking the cabinet with your hand.

Under these circumstances, the set is not at fault. The trouble is simply that it is not being fed enough signal from the antenna.

Natural static has practically no effect upon ultra-frequency reception. Both sight and sound come through, for example during thunder storms without interference from the lightning. The most common source of interference is from automobile ignition. In time, it is reasonable to expect that all cars and trucks will have noise-suppressors as standard equipment. This may be required by law in the near future, for the noise-suppressors used on cars fitted for radio broadcast reception do not cause television interference. Meanwhile, since cars operate on the streets, the simple way to cut down ignition noises is to move the di-pole away from the source of interference by increasing its height. This, of course, not only reduces the interference but increases the signal strength.

If in addition to getting interference, you have weak signals, this is doubly serious. Just as you increase the background noise of

a broadcast receiver when you turn up the volume to maximum, so you increase the interference and its effect on the picture produced by a television receiver when you turn the contrast control to maximum.

Faint, grey pictures are the result of faint signals. The fact that they may not slip simply means that you are in a good location, free from interference.

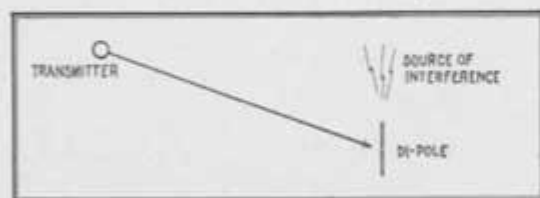

FIG. 69. AT A SLIGHT LOSS OF SIGNAL STRENGTH, INTERFERENCE MAY BE CUT DOWN BY POINTING THE TELECEPTOR AT THE SOURCE.

In this connection, it should be pointed out that automobile ignition or other impulses may interfere with the picture even though they are not strong enough to be heard in the loudspeaker. On the other hand, you may have serious interference on broadcast reception which will not affect ultra-frequency television at all!

A Simple Check: Because television reception involves so many new factors, the public and even dealers and servicemen do not understand it thoroughly. Therefore, it is natural to blame the receiver for any kind of failure to produce satisfactory pictures.

The writer's experience with several hundred television installations shows that more than 50% of reports¹ of "failure to operate" when the sets were first installed were not the result of failure in the receiver itself, but were due to mistakes in erecting and adjusting the antenna. These ranged from short-circuits in uninsulated lead-in joints and lack of care in orienting the di-pole to cases of insufficient height.

Consequently, since the reason for unsatisfactory performance must lie in the set

¹Of the remaining reports, slightly more than half were due to failure to adjust the picture size and hold controls. The balance were due to defective tubes. Not one case of actual defect in the receiver was found.

or the antenna, if you do not get proper reception, the simplest check is to try your receiver at some other installation where good results are being obtained. Your radio dealer should be able to let you make such a check at his store, or you may prefer to take your set to the home of a friend.

Then, if something is wrong with the adjustments on the set, or with the tubes, you can localize the trouble.

On the other hand, if your set gives perfect reception, you will know that you must make adjustments or changes in your own antenna.

Increasing the Height: The advantages in increasing the signal strength and reducing interference by raising your Teleceptor have been described already in this Chapter. To give you one of many examples of improvement obtained in this manner: An installation was made on Halsey Street, in Newark, N. J. This street is in "automobile row," so that serious ignition interference was expected. When the Teleceptor was mounted on a 3-story building, with the lead dropping straight down to the receiver, there was a moderately good picture signal, but the interference was very bad indeed.

In fact, the images were torn by the constant stream of automobile traffic and, despite the strength of the picture signals, the interference was sufficient at times to blanket the synchronizing impulses, so that the picture slipped annoyingly.

Accordingly, the Teleceptor mast was raised to the top of a 20-ft. mast. This not only took the di-pole out of the strong field of the ignition interference, thereby reducing that trouble, but it increased the picture signal so that the contrast control could be cut down, and the amplification of the interference reduced substantially.

As a result, what had been very poor reception was made entirely satisfactory, just by raising the Teleceptor 20 ft.!

When to Use Coaxial Cable: As a rule, the loss from increasing the length of the twisted pair lead-in is more than offset by the increase in signal pick-up when the lead drops straight down to the set. However, if the Teleceptor is not directly above the re-

ceiver, necessitating a long lead coming down at an angle, that may not be so.

Consider the case of a radio dealer whose store is in a low building. The first antenna, put upon the store, was inadequate because it was shielded by a high apartment house, one hundred feet to the side. To gain height, the dealer obtained permission to put his Teleceptor on the roof of the apartment house.

This gave an increase in height of 125 ft. However, bringing the lead over to his store lengthened his lead-in by 90 ft. There was some improvement in reception after this change had been made, but not enough. The signal gain was nearly offset by the added resistance of the lead.

To overcome this, since the lead could not be shortened, a coaxial cable was substituted for the twisted pair lead, to reduce the resistance. In this way, the loss from the lead-in was reduced sufficiently to give highly satisfactory sight and sound.

No Pick-up from Lead: In planning your television antenna, remember that the signals are picked up only by the horizontal di-pole. The twisted pair and coaxial cable are used in order to prevent pick-up by the lead-in. The only purpose of the lead is to connect the di-pole to the receiver.

Ground Connection: It is highly important to use a ground connection on a television receiver. You will see from the schematic diagram of the Andrea set that the antenna coil is designed for a grounded center tap.

It is important to use insulated wire for the ground lead, and to solder it to the ground clamp. Uninsulated wire touching some metal object, or a poor ground connection, may make a variable-resistance contact that gives the effect of static interference. Use an insulated ground wire, and solder the connection.

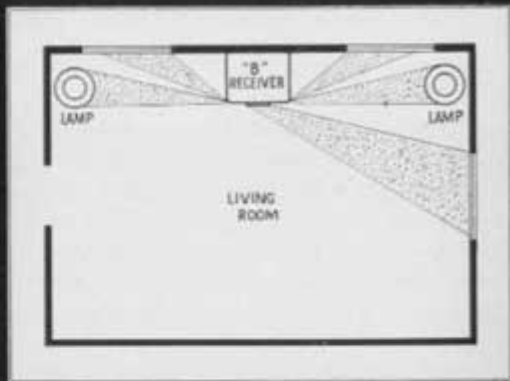
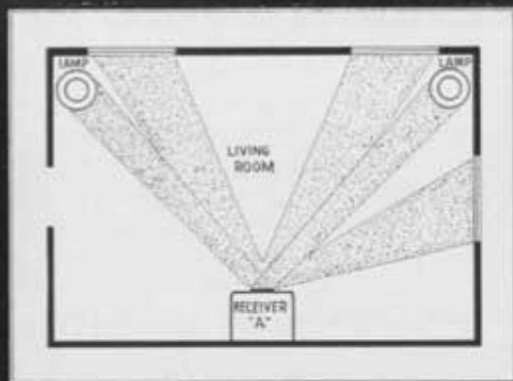

FIG. 70. LEFT, THE WRONG WAY TO SET UP A TELEVISION RECEIVER. RIGHT, THE LIGHT IS KEPT OFF THE FRONT OF THE SET.

CHAPTER SIX

Important notes on the installation of television receivers

When people get new appliances for their homes, or new machines for their offices or factories, they study the instructions for installation and operation, so as to make sure they set up the new equipment properly, and use it correctly.

Study These Instructions: For some strange reason, that is not the case when people buy television receivers. They spend two hundred to seven hundred and fifty dollars for the sets and then, possibly because television receivers have knobs to turn, like the familiar broadcast sets, they try to tune in television without even giving the instructions a glance.

Then what happens? Of course they don't use the controls correctly, and they say: "This television set is no good!" when the fault does not lie in the equipment, but in the way it is handled.

Do you think that is an exaggeration? Unfortunately, it is literally true. The writer has straightened out many complaints of exactly that sort! And this may surprise you: The people who refuse most consistently to inform themselves by reading the television instructions and who consequently make the most stupid mistakes, are the radio dealers!

The things you need to know, the things which make the difference between excellent and poor reception, are so simple! You can

avoid all the silly, obvious mistakes by reading this Chapter carefully.

Where to Place the Set: If you put a television receiver where either daylight or artificial light shines directly on the front of the picture tube, you will NEVER get satisfactory reception. Furthermore, you will burn out your picture tube in half its normal life.

Why? For the reason that, with direct light on the tube, you will have to turn up the brightness control far beyond normal brilliance in order for the pictures to show up. In that condition, the sharpness of the pictures is destroyed from overloading. In addition, this excessive brightness tends to burn the coating on the front of the tube. Very soon, a brown spot will appear in the center of the screen, and when you complain about that, you will be told: "The tube is not defective. You have burned the screen by operating the tube at excessive brightness. You are at fault—not the tube."

The ideal place for a television set is in the cellar play room, where practically all the light can be cut off, even during the day. In apartments, of course, that is out of the question. Fig. 70 shows two arrangements in a conventional living room. The first is wrong in every respect. During the day, light will

shine on the tube from the windows, and at night from the floor lamps.

The second layout is much improved. A minimum amount of light is directed at the set from the windows, and the floor lamps cannot shine on the front of the receiver. If the curtains are pulled down over the windows, good reception will be possible during the day. Still further improvement can be attained by shading the set with a folding screen.

How Dark Must the Room Be?: There are two simple checks for the permissible amount of light. First: Black-and-white picture tubes generally appear blue-and-white if there is too much illumination in the room. When the room is dark enough, the pictures will be actually black-and-white, and will appear in the maximum sharpness of detail.

Second: Adjust the set for the clearest pictures you can get. Then darken the room still further. If, upon reducing the brightness control, the pictures show up more clearly, the room was too light in the first place.

Perhaps the instructions for using the controls should have come before these notes about locating the set. However, no amount of expert manipulation can get good results from a set if it is not placed correctly in the room where it is to be used!

Adjusting Contrast & Brightness: The use of these controls has been described briefly, but this subject requires a little elaboration. When you reduce the contrast, the picture fades out. Consequently, the tendency is to increase the contrast, making the picture brighter, and the cutting it down by reducing the brightness. The usual result of this is to get too much contrast. That is, the picture is all black and white, without the shades of grey needed to give naturalness.

Here is the proper procedure for using the contrast and brightness controls: Before you turn the set on (and also before you turn the set off) put the brightness control at zero. Switch the set on, allow about thirty seconds for the tubes to reach their operating temperature, and turn up the contrast just a little. Increase the brightness until the screen begins to light up.

Now, increase the contrast until you can see a picture. Probably, the picture will be slipping up, due to the insufficient signal strength. Turn the contrast up until the picture locks in frame.

Do not turn the contrast control any farther beyond that point than is necessary. Readjust the brightness, and then the contrast, until you have natural shades of grey in the picture, but get your pictures with the **CONTRAST CONTROL AS LOW AS POSSIBLE.**

This serves two purposes. First: This will keep down interference from ignition. Second: It will avoid over-contrast in the pictures, evidenced by extreme blacks and whites.

Correct Use of Focus Control: The focus control regulates the size of the dot of light which makes the lines of the picture. When it is adjusted correctly, the dot is exactly large enough so that one line just touches the next line. Since the focus, i.e., the size of the dot of light, is affected by a change of the contrast or brightness controls, it may be necessary to reset the focus control if either of the other two is changed.

Correct Picture Size: Be careful not to make the picture larger than the opening of the mask in front of the picture tube. The opening of the mask on any television receiver is made just the size to which the picture should be adjusted. If you make the picture larger, you will introduce distortion. Once in a while, turn the vertical and horizontal centering controls slightly during television reception, to see that the edges of the picture are not outside the opening of the mask. These controls are at the rear of the chassis. This should be done during actual reception, for the raster, seen when there is no station on the air, is somewhat larger than the actual picture size. Controls for adjusting the picture height and width are at the rear of the chassis.

60 Cycles Only: Fortunately, there are very few places in the U.S.A. where 50-cycle or 25-cycle current is used, because standard television receivers, designed for operation in this country, will only work on 60 cycles. The Andrea receiver described in this volume operates on 60-cycles, 110 to 130 volts.

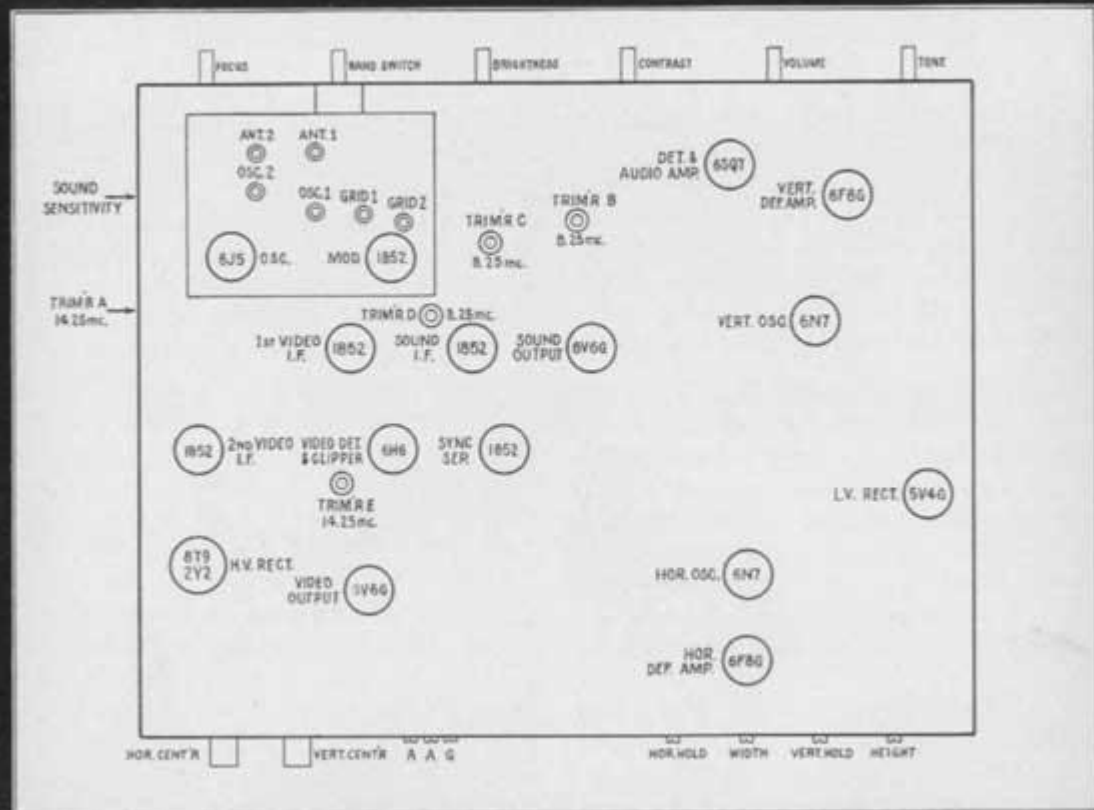

FIG. 71. TOP OF THE CHASSIS, SHOWING THE TUBE LAYOUT, AND THE LOCATION OF THE VARIOUS ADJUSTMENTS.

CHAPTER SEVEN

Service Notes and Trouble-Shooting Charts for the Andrea models 1-F-5 and KT-E-5 sight-and-sound receivers

Service work on television receivers can be divided into two parts: 95% can be done with the conventional instruments which every serviceman has already, plus an ultra-frequency oscillator; 5% requires instruments that individual servicemen and most dealers would not be justified in buying.

It appears, therefore, that the jobbers will have to take upon themselves the investment in instruments required for the 5% part of service problems. Dealers and servicemen will handle all but this very small part of the work, and when a condition arises which they cannot meet, they will have to deliver the set to the jobber's service shop, since the equipment needed in such cases is hardly portable,

nor would it be wise to do the work in the customer's home.

95% Are Simple Cases: As you will discover when you become acquainted with television receivers, they are quite different, electrically and mechanically, from broadcast sets. Since the slightest deviation from extremely high standards of precision design shows up unequivocally in the picture tube, such compromises in specifications and tolerances as have been adopted widely in sound receivers cannot be made in television circuits.

The use of high voltage exerts an important influence in television set design. If

parts break down in sound equipment, it is easy to replace whatever has gone wrong. When several thousand volts get loose, however, expensive damage may result. Finally, cheap materials and inferior designs are not suitable for ultra-frequency television circuits.

Thus, the superior materials and construction necessary for television equipment eliminate the source of many failures common to the average sound receiver. There is a sufficient background of experience already to indicate that service work on the Andrea I-F-5 and the KT-E-5 models is almost entirely a matter of tube failures. The most important part of service instructions for the I-F-5 and the corresponding KT-E-5 kit is the table of tube-failure symptoms.

Instructions for adjusting the trimmers and sound traps, and for setting the tubular condensers are given here, although it is not unusual to find that they need readjustment. The video I.F. transformers are so designed and matched that no provision for further alignment is needed, nor is provided.

High-Voltage Hazard Eliminated:

From the foregoing, you can see that there is no high-voltage hazard involved in 95% of the television service work. The 5% to be done by the jobber's service department may require special tests to be made with the current on, but the serviceman who makes the conventional tests for which he is equipped does not need to take any risk whatever. He can do his work without removing the bottom plate.

Checking Tube Failures: If you have determined that the fault lies in the set and not in the antenna, the first source of trouble to examine is the tubes. Consequently, a set of tested tubes must be at hand for television service work. Different tubes display quite definite symptoms of failure. With the Chart provided here, it is easy to locate the defective tube quickly. Fig. 71 shows the positions and functions of the various types.

Having determined the symptom, change the faulty tube indicated in the Chart. If that does not remedy the condition, see if there is another tube which, if faulty, shows the same or somewhat similar symptom.

There are several cases of duplication, so that you may have to try replacing a second or third tube before the failure is located and corrected.

Adjusting Sound I.F. Trimmers: Following are the steps in which the sound I.F. trimmers should be adjusted:

1. Remove the 879 or 2Y2 high-voltage rectifier tube as a measure of safety.
2. Connect a signal generator to pin 4 of the 1852 modulator tube. Set the generator accurately at 8.25 mc.
3. Put a rectifier-type meter across the voice coil of the loudspeaker. It is preferable to use a meter having 2,000 ohms per volt.
4. Adjust trimmers B, C and D for maximum output, as indicated by the meter. After the initial adjustments, go over them carefully a second time.

Adjusting Sound-Trap Trimmers: The sound-trap trimmers are provided to keep the audio signals out of the video circuits. These trimmers should be adjusted as follows:

1. Remove the socket from the base of the picture tube. Connect a rectifier-type meter from 10 on the picture tube socket to the ground, through a .5 mfd., 600-V. paper condenser.
2. Connect a signal generator to pin 4 of the 1852 modulator tube. Set the generator accurately at 14.25 mc.
3. Adjust the signal generator for maximum deflection on the meter.
4. Adjust trimmers A and E for minimum deflection of the output meter.

Note: The signal generator frequency must be accurate. Otherwise, this adjustment may be carried out on a frequency within the pass-band of the video I.F. resulting in audio interference in the picture.

Adjusting Sound Sensitivity: The normal position for the sound sensitivity condenser is when the variable plate is half-way interleaved with the fixed plates. To adjust this condenser, turn the shaft very slowly until the maximum audio signals are obtained. If the adjustment of this condenser

CHART INDICATING TUBE FAILURES

<i>Tube and Function</i>	<i>Picture</i>	<i>Sound</i>	<i>Sync</i>	<i>Miscellaneous</i>
1852 Modulator	Rasster, no picture			
	Picture			Tube is microphonic, gray bars appear when cabinet is tapped, or when loud audio signals are heard.
6J5 Oscillator	Distorted picture			
	No picture	No sound		
1852 1st Video I.F.	No picture	Sound O.K.		
1852 2nd Video I.F.	No picture	Sound O.K.		
6H6 Video Detector and Clipper	No picture	Sound O.K.		
	Picture		Slipping	
6V6G Video Output	No picture	Sound O.K.		
1852 Sync Separator	Picture	Sound O.K.	Slipping	
6N7 Vertical Oscillator	Insufficient height			
	Out of frame			Picture syncs slightly down from top or up from bottom.
6F8G Vert. Deflection Amp.	Insufficient height			Picture may appear as merely a horizontal line.
6N7 Horizontal Oscillator	Insufficient width			Picture may appear as a vertical line.
6F8G Hor. Deflection Amp.	Insufficient width			Picture may appear as a vertical line.
879 or 2Y2 High Voltage Rectifier	No picture	Sound O. K.		Centering controls have no effect.
5V4G L. V. Rectifier	No picture	No sound		
1805—P4 Picture Tube	Momentary			Momentary picture, screen blooms, picture disappears.
	Burned spot			Yellow spot: due to operation at excessive brightness.
	Dull			Dull picture due to long use of picture tube
	Odd Size			Note: If faulty picture size can not be corrected by size or hold controls, look for open connection from cable to picture tube socket.
1852 Sound I.F.	Picture O.K.	No sound		
6SQ7 Detector and 1st Audio	Picture O.K.	Microphonic howl		
	Picture O.K.	No sound		
	Picture O.K.	Distortion		
	Picture O.K.	Noise in speaker		
6V6G Audio Output	Picture O.K.	No sound		
	Picture O.K.	Weak, distorted		

Other Failures: If, after checking the tubes, reception of pictures or sound is not satisfactory, go through the Sight and Sound Chart. Instructions for trimmer adjustments and R.F. alignment are included in this Chapter.

SIGHT AND SOUND CHART

SYMPTOM	REMEDY
Picture will not hold vertical sync	Adjust vertical hold control. Do this with contrast control as low as possible. Insufficient Signal: Antenna must be oriented, moved to more favorable location, or raised in height. Ratio of signal to noise may be too low. Increase height of antenna. If lead is over 100 ft. long, coaxial cable may be required. Note: May be due to losses introduced by antenna leads to other television receivers. Remove such leads. Interference: Ratio of signal to noise may be too low. See Insufficient Signal notes above.
Picture tears	Adjust horizontal hold control. Interference: Ignition interference may cause tearing in all or part of the picture area. See Insufficient Signal notes above.
Picture shows horizontal distortion	Adjust horizontal hold control. Interference: See Insufficient Signal notes above.
Picture is broken by angular pattern	Interference: See Insufficient Signal notes above.
Picture has white retrace lines	Brightness control too high, contrast control too low. Insufficient signal: If contrast control is at maximum see Insufficient Signal notes above. Transmitter adjustment is not correct.
Picture is distorted by sound	Adjust trimmers A and E for minimum signal at 14.25 mc.
Pictures without sound	Adjust trimmers B, C, and D for maximum audio output at 8.25 mc., and check adjustment of Sound Sensitivity trimmer at the side of the chassis.
Pictures and sound weak	As a last resort, after you have checked everything else, realign R.F. plunger condensers.

affects the pictures, adjust the condenser until there is no interference with the picture. Then readjust trimmers B and C, and finally readjust the sound sensitivity condenser.

Adjusting R.F. Alignment: Since the R.F. unit of the Andrea 1-F-5 receiver and KT-E-5 kit are aligned with great precision at the factory, and because the designs of the parts have been found exceedingly stable under all operating conditions, it is most unlikely that realignment will be necessary. However, in case the adjustments are changed for any reason, realignment should be carried out in the following manner:

Note: These instructions apply to television channels 1 and 2. If your set is equipped

for receiving other channels, follow the special data supplied by the Andrea factory. Keep the bottom plate on the chassis during the R.F. alignment.

1. Because of the design of the R.F. unit, Band 2 must be aligned first, and Band 1 afterward. Incorrect settings will be obtained if Band 1 is aligned first.

2. Make sure that the sound I.F. trimmers have been adjusted to 8.25 mc. Otherwise, the R.F. alignment will not be accurate.

3. Connect a signal generator to terminals A,A of the receiver. Set the generator accurately at 55.75 mc. (55,750 kc.).

4. Put the band switch on channel 2.

5. Connect a rectifier-type meter across the voice coil of the loudspeaker.

6. Loosen the locknut on Oscillator Condenser 2, so that the plunger moves freely. It is a great help to have a tool with a side pin to hook into the hole in the plunger.

7. Adjust the plunger for maximum output. Tighten the locknut part way.

8. When the locknut is nearly tight, readjust the plunger. Then tighten the locknut firmly.

9. Connect the rectifier-type meter from 10 on the picture tube socket to the ground, through a .5 mfd., 600-V. paper condenser.

10. Adjust the signal generator to 52.5 mc. (52,500 kc.).

11. Turn the chassis on its side, and slip a Spintite wrench through the hole in the bottom of the chassis, and put it over the tubular bottom end of Grid Condenser 2. This is to detune it slightly.

12. Loosen the locknut on Antenna Condenser 2, and adjust the plunger for maximum picture output, as indicated by the

meter. Then tighten the locknut part way, readjust the plunger, and tighten the locknut firmly.

13. Remove the Spintite from Grid Condenser 2, and put it on Antenna Condenser 2.

14. Loosen the locknut on Grid Condenser 2, and adjust the plunger for maximum picture output, as indicated by the meter. Then tighten the locknut part way, readjust the plunger, and tighten the locknut firmly.

15. To align Band 1, carry out the preceding steps to 14 using 49.75 mc. for the signal generator (step 3), put the band switch on Channel 1 (step 4), and adjust Oscillator Condenser 1 (step 6).

16. Use 46.5 mc. for the signal generator (step 10) and use Grid Condenser 1 and Antenna Condenser 1 in the subsequent steps.

This completes the realignment of Bands 1 and 2.

CHAPTER EIGHT

Dictionary of Television Terms

- ACCELERATING VOLTAGE.**—See Voltage, Accelerating.
- AMPLIFIER, CONTROL.**—Amplifier operated from the output of the shading panel, at which the pedestal voltage level is set, the pedestal voltage level being the level corresponding to black.
- AMPLIFIER, SHADING.**—See Panel, Shading.
- AMPLIFIER, VIDEO LINE.**—Amplifier, operated from the control panel, in which the completed television signal impulses are amplified sufficiently to be conducted by coaxial cable to the radio transmitter.
- AMPLIFIER, VIDEO PRE.**—Wide-band amplifier which amplifies the camera tube signal voltage sufficiently for transmission to the monitor booth.
- AMPLITUDE, MAXIMUM.**—The maximum amplitude of video signal corresponds to the black portion on the received image. Note: This is opposite to the current practice in England.
- AMPLITUDE, MINIMUM.**—The minimum amplitude of the video signal corresponds to a white or bright spot on the received image. Note: This is opposite to the current practice in England.
- APERTURE.**—The size of the scanning spot in the camera tube, or the size of the scanning spot in the image tube.
- APERTURE DISTORTION.**—See Distortion, Aperture.
- ASPECT RATIO.**—Ratio of the width to the height of the image. This is standardized in the U.S.A. at 4:3.
- AVERAGE LEVEL.**—See Level, Average.
- BEAM, CATHODE RAY.**—The stream of electrons generated at and flowing from the electron-emissive cathode of a cathode ray tube or electron gun. This beam, impinging upon the fluorescent coating at the end of a cathode ray tube or kinescope, forms a luminous spot.
- BLANKING.**—(Or "blanking out") To make black, by cutting off the source of illumination.
- BLANKING SIGNAL.**—See Signal, Blanking.
- BLIZZARD HEAD.**—(Studio slang) A blonde actress.
- BOOTH, MONITORING.**—The booth occupied by the video monitoring operator. The principal equipment operated in this booth comprises: Controls for regulating voltages applied to, and for modifying the signal coming from, the camera tube; television image tube; cathode ray monitoring oscilloscope; shading controls; and brightness control.
- BOWL.**—(Studio slang) A bowl-like lighting unit for general illumination.
- BRIGHTNESS, OVERALL.**—The difference or contrast between the lightest and darkest parts of a television image.
- BROAD.**—(Studio slang) Lighting units used for general illumination.
- BUSINESS.**—(Studio slang) Anything for which there is no specific name, or of which the name has been forgotten.
- CABLE, COAXIAL.**—A two-conductor cable, one conductor of which is a tube surrounding and insulated from the other.
- CAMERA, PICK-UP.**—The camera tube and associated equipment used for viewing images to be transmitted by television.
- CAMERA TUBE.**—See Tube, Camera.
- CATHODE RAY BEAM.**—See Beam, Cathode Ray.
- CATHODE RAY TUBE.**—See Tube, Cathode Ray.
- CENTER UP.**—(Studio slang) To center the composition of the picture at the television studio.
- CIRCUIT, SWEEP.**—Circuit controlling the position of the cathode ray beam. This generally refers to the horizontal movement of the beam.
- COAXIAL CABLE.**—See Cable, Coaxial.
- COILS, DEFLECTING.**—Magnet coils located adjacent to the neck of a cathode ray tube or kinescope which, by the influence of their electromagnetic influence, deflect the electron stream. These magnets are generally in pairs on opposite sides of, and with their cores at right angles to, the neck of the tube. When the coils are energized, the electron stream, or beam, is deflected in a plane at right angles to the cores of the magnets.
- CONTROL AMPLIFIER.**—See Amplifier, Control.
- CONTROL GRID.**—See Grid, Control.
- CONTROL VOLTAGE.**—See Voltage, Control.
- CORRECTED SIGNAL.**—See Signal, Monitored.
- DEFLECTING COILS.**—See Coils, Deflecting.
- DEFLECTING VOLTAGE.**—See Voltage, Deflecting.
- DI-POLE.**—A rod-type antenna, divided at the center and balanced to ground. The total length of the two halves is approximately $\frac{1}{2}$ the wavelength of the resonant frequency. Impedance measured at the center is about 72 ohms. Television di-poles are mounted horizontally in the U.S.A.; vertically in England.
- DISTORTION, APERTURE.**—Loss of definition due to the finite size of the aperture. Aper-

- ture distortion would be eliminated by an aperture of infinitely small diameter.
- DISTORTION, NON-LINEAR.**—Distortion due to departure of the scanning wave from linear form, evidenced by crowding of some part of the received image. Caused by poor low frequency or high frequency amplification.
- DOLLY.**—Moveable platform on which the camera is shifted about in the studio.
- DOUBLE IMAGE.**—See Image, Double.
- ELECTRON GUN.**—A metal structure, sealed in vacuum, having an electron-emissive cathode (generally heated), and accelerating electrodes with holes to form and direct the beam of electrons from the cathode. The electrodes are at adjustable potentials to focus the stream at any desired distance from the cathode.
- ELECTRON MULTIPLIER.**—A vacuum tube device comprising a source of primary electrons and a secondary, emissive target which gives off a greater number of electrons than the number of primary electrons striking the target. The multiplication factor is the ratio between the number of secondary and primary currents.
- ELECTRO-MAGNETIC SCANNING.**—See Scanning, Electro-magnetic.
- ELECTRO-STATIC SCANNING.**—See Scanning, Electro-static.
- FLAT LIGHTING.**—General illumination from wide-angle lighting units.
- FLYBACK.**—(English term) The return trace of the cathode ray beam.
- FOCUS.**—(Of image receiver) To control the size of the luminous spot in the kinescope tube.
- FOCUSING VOLTAGE.**—See Voltage, Focusing.
- FRAME.**—The complete reproduction of a single television image. Current practice calls for 441 lines per frame, and 30 frames per second.
- FRAME RETRACE.**—See Retrace, Frame.
- FRAME RETURN.**—See Retrace, Frame.
- GENERATOR, SYNCHRONIZING.**—Generator of accurately timed impulses for initiating the start of each line scanned, and the beginning of each interlaced half frame. These impulses control the horizontal line scanning and the vertical frame scanning. This generator also applies the blanking signal voltage to the control grid of the camera tube, to extinguish the beam during the return trace following each scanning line, and at the end of each frame.
- GHOST.**—See Image, Double.
- GOBO.**—(Studio slang) Light-deflecting fins used to direct lighting and to protect the lens from glare.
- HORIZONTAL SWEEP VOLTAGE.**—See Voltage, Horizontal Sweep.
- HOT LIGHT.**—(Studio slang) A spot light for emphasizing features.
- ICONOSCOPE.**—See Tube, Camera.
- ILLUMINATION-INTEGRATOR.**—See Integrator, Illumination.
- IMAGE DISSECTOR.**—Camera tube used by Farnsworth. Employs a flat photo-electric surface. Gains sensitivity through use of electron multiplication.
- IMAGE, DOUBLE.**—One or more similar images, slightly offset and imposed upon one another, produced at the receiving station by separate signals arriving by different paths.
- IMAGE TUBE.**—See Tube, Image.
- IMPULSES, LINE.**—The impulses furnished by the synchronizing impulse generator. The number of line impulses per second is the product of the number of lines in the complete frame, or image, and the number of frames per second. On current practice: $441 \text{ lines} \times 30 \text{ frames per second} = 13,230 \text{ line impulses per second}$.
- INTERLACE.**—(Noun) One half of a complete frame, or image, comprising every other line. A second interlace is required to fill the intervening lines, in order to complete one frame. (Verb) To form a frame by scanning every other line, and then scanning the intervening lines, thereby completing the frame. The frame is interlaced by scanning the lines in the order 1, 3, 5, 7, 9, etc., and then lines 2, 4, 6, 8, etc.
- INTEGRATOR, ILLUMINATION.**—An automatic background illumination regulator, controlled by a photo-tube.
- KINESCOPE.**—A type of cathode ray tube having a luminous screen of very slight persistency, so as to be suitable for television image reception.
- LEVEL, AVERAGE.**—Average voltage level at pedestal amplifier due to background illumination.
- LEVEL, PEDESTAL.**—The signal voltage level corresponding to black, or slightly "blacker than black." This level is also required during the synchronizing interval, and during the return trace of the receiving cathode beam.
- LINE IMPULSES.**—See Impulses, Line.
- LINE RETRACE.**—See Retrace, Line.
- LINE RETURN.**—See Retrace, Line.
- LINE, TRANSMISSION.**—Two parallel conductors, usually balanced with respect to ground, used to convey signals from one circuit position to another. A transmission line has two distinguishing characteristics: surge impedance and velocity of propagation. When terminated in a resistance equivalent to its surge impedance, no reflections take place on the line. The impedance is a function of the ratio of spacing between the conductors to their diameter.
- LINK, RADIO FREQUENCY.**—A wireless circuit, comprising a radio transmitter and a receiver.

- MAGNETIC SCANNING.**—See Scanning, Electro-magnetic.
- MAXIMUM AMPLITUDE.**—See Amplitude, Maximum.
- MINIMUM AMPLITUDE.**—See Amplitude, Minimum.
- MODELLING.**—(Studio slang) The use of a spot light to emphasize features.
- MONITORED SIGNAL.**—See Signal, Monitored.
- MONITORING BOOTH.**—See Booth, Monitoring.
- MONITOR, VIDEO.**—Manually operated controls for regulating voltages applied to, and for modifying the signal voltages which come from, the camera tube.
- MONOSCOPE.**—A tube used to transmit a single still picture, comprising half-tones or lines, for television test purposes. The signal plate is coated with aluminum-foil on which the picture is printed in black-foil ink. Before sealing the envelope, the signal plate is fired with hydrogen to remove the volatile matter from the ink, leaving practically pure carbon.
- MOSAIC.**—Light-sensitive screen in camera tube, on which the image is focused. The screen is of mica, with a metal coating at the rear which serves as the electrode to which the output circuit is connected and, on the front, a coating of globules of caesium-oxide-silver. These globules are less than .001 in. in diameter.
- MOSAIC TUBE.**—See Tube, Camera.
- NARROW-VERTICAL SYNCHRONIZING.**—See Synchronizing, Narrow-Vertical.
- NON-LINEAR DISTORTION.**—See Distortion, Non-Linear.
- OPERATOR, VIDEO.**—The operator of the monitoring booth who checks the images and the character of the television signals, and regulates the shading panel controls by which corrective voltages are applied to the camera tube and associated circuits.
- OSCILLOSCOPE, MONITORING.**—A cathode ray tube, generally mounted in the monitoring booth, which shows the video signal from the camera as a function of time. That is, it shows the voltage in the vertical direction against time in the horizontal direction. Thus the relative amplitude of the video signals and synchronizing impulses indicate the character of the television signal.
- OVERALL BRIGHTNESS.**—See Brightness, Overall.
- PANEL, SHADING.**—Control panel, located in monitoring booth, with controls by means of which properly shaped neutralizing voltages, generated separately, are applied to correct imperfections in the camera tube signal.
- PANNING.**—(Studio slang) Movement of the studio camera tube in a horizontal direction.
- PEDESTAL LEVEL.**—See Level, Pedestal.
- PICK-UP CAMERA.**—See Camera, Pick-up.
- PICTURE TUBE.**—See Tube, Picture.
- PICTURE VOLTAGE.**—See Voltage, Picture.
- PLATE, SIGNAL.**—The light-sensitive plate of the camera tube, on which the image is focused.
- PRE-AMPLIFIER.**—See Amplifier, Video Pre-Radio Frequency Link.
- RADIO FREQUENCY LINK.**—See Link, Radio Frequency.
- RETRACE, FRAME.**—The non-useful interval between the end of the first interlace and the beginning of the second, or between the second interlace of one frame and the beginning of the first interlace of the succeeding frame.
- RETRACE, LINE.**—The non-useful interval between the end of the scanning of one line and the start of scanning the next line.
- RETURN TRACE.**—See Trace, Return.
- RUN THROUGH FOCUS.**—(Studio slang) To check the focus on the entire studio system, and to balance the finder lens against the action lens.
- SCANNING, ELECTRO-MAGNETIC.**—Control of the movement of the electron stream of a cathode ray tube by applying current to the deflecting coils mounted at right angles to the neck of the tube.
- SCANNING, ELECTRO-STATIC.**—Control of the movement of the electron stream of a cathode ray tube by applying voltages to the deflection plates mounted within the tube.
- SCANNING LINE.**—See Line, Scanning.
- SCOOP.**—(Studio slang) Multiple lighting units.
- SERRATED IMPULSE SYNCHRONIZATION.**—See Synchronization, Serrated Impulse.
- SHADING AMPLIFIER.**—See Panel, Shading.
- SHADING PANEL.**—See Panel, Shading.
- SIGNAL, BLANKING.**—The voltage from the synchronizing generator, applied to the control grid of the camera tube, to extinguish the beam during the return trace, following each scanning line, and at the end of each frame.
- SIGNAL, CORRECTED.**—See Signal, Monitored.
- SIGNAL GENERATING TUBE.**—See Tube, signal generating.
- SIGNAL, MONITORED.**—The signal output from the control amplifier, on which the video, blanking, and synchronizing impulses have been impressed.
- SIGNAL PLATE.**—See Plate, Signal.
- SIGNAL, VIDEO.**—The signal output of the television camera tube.
- SPOT.**—Glow in the coated surface of the cathode ray tube, caused by the bombardment of electrons in the cathode ray, or beam.
- SWEEP.**—Movement of the cathode ray beam. This may refer to horizontal or vertical movement, or both.
- SWEEP CIRCUIT.**—See Circuit, Sweep.
- SYNC.**—Abbreviation for "synchronous."
- SYNCHRONIZATION, SERRATED IMPULSE.**—A method of frame synchronizing in which indentations of the pedestal voltage are used, of the same amplitude as the line synchroniz-

- ing impulses, but of substantially different shape.
- SYNCHRONIZING GENERATOR.**—See Generator, Synchronizing.
- SYNCHRONIZING, NARROW-VERTICAL.**—A method of frame synchronizing in which the same type of impulse is used as for line synchronizing, except that it is of greater amplitude, in the ratio of at least 2:1. This method of frame synchronizing is not generally favored, since this requires such a large part of the carrier amplitude that it is considered wasteful of available video carrier modulation.
- TILTING.**—(Studio slang) Movement of the studio camera tube in a vertical direction.
- TRACE.**—Movement of the cathode ray spot across the screen.
- TRACE, RETURN.**—The line, ordinarily blanked out by the transmitted signals, formed on the picture tube screen when the beam returns from the end of one line to start the next, or from the end of one interlace to start the next interlace.
- TRANSMISSION LINE.**—See Line, Transmission.
- TUBE, CAMERA.**—The device which translates the image at the studio into electrical impulses. It comprises an electron gun and a light-sensitive screen sealed in a common, evacuated envelope which has an optical glass window through which the image is focused on the screen.
- TUBE, CATHODE RAY.**—A metal structure, sealed in an evacuated envelope, by means of which an electron stream is caused to flow from an electron-emissive cathode. The electron stream is concentrated, and caused to impinge on a screen of fluorescent material, creating a luminous dot. The stream, and consequently the dot, is deflected horizontally or vertically by electro-magnetic or electrostatic fields, or combinations of both. It should be noted that the electron stream can be deflected with great speed because it has no inertia.
- TUBE, IMAGE.**—(Receiver) A cathode ray tube suitable for producing television images at the receiving station. (Monitoring booth) A receiving tube, mounted in the monitoring booth, which shows the image from the output of the video line amplifier, so that its quality and defects can be seen.
- TUBE, KINESCOPE.**—See Kinescope.
- TUBE, MOSAIC.**—See Tube, Camera.
- TUBE, PICTURE.**—A cathode ray tube suitable for producing television images at the receiving station.
- VERTICAL SWEEP VOLTAGE.**—See Voltage, Vertical Sweep.
- VIDEO.**—Referring to sight.
- VIDEO LINE AMPLIFIER.**—See Amplifier, Video Line.
- VIDEO MONITOR.**—See Monitor, Video.
- VIDEO OPERATOR.**—See Operator, Video.
- VIDEO PRE-AMPLIFIER.**—See Amplifier, Video Pre.
- VIDEO SIGNAL.**—See Signal, Video.
- VOLTAGE, ACCELERATING.**—Voltage applied to an anode of a cathode ray tube or kinescope to accelerate the flow of the electron stream, or beam.
- VOLTAGE, DEFLECTING.**—Voltage applied to the electrodes of a cathode ray tube, by means of which the beam is deflected vertically or horizontally.
- VOLTAGE, CONTROL.**—(Television transmitter) Synchronizing voltages from the synchronizing impulse generator. (Television receiver) The picture and focusing voltages applied to the cathode ray tube.
- VOLTAGE, FOCUSING.**—The adjustable voltage applied to the first anode of a cathode ray tube. This voltage controls the diameter of the luminous spot.
- VOLTAGE, HORIZONTAL SWEEP.**—Voltage applied to the electrodes of a picture tube, by means of which the beam is deflected to the left or right.
- VOLTAGE, PICTURE.**—The fixed voltage applied to the second anode of a cathode ray tube. This voltage is set to give the maximum brilliant that can be used without burning the coating at the end of the tube.
- VOLTAGE, VERTICAL SWEEP.**—Voltage applied to the electrodes of a picture tube, by means of which the beam is deflected up and down.
- WINDSHIELD.**—A perforated cover on the microphone to protect it from the wind currents set up by the powerful air-conditioning system required to cool the television studio.
- WOMP.**—(Studio slang) Any sudden video voltage surge of unknown origin.