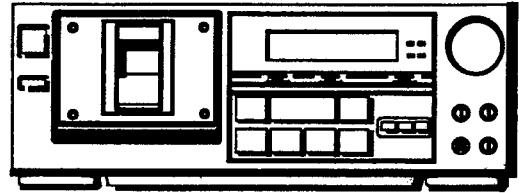

**AIWA®****AD-F800****SERVICE  
MANUAL**

STEREO CASSETTE DECK

• BASIC TAPE MECHANISM :  $\alpha - 12$ 

• TYPE. H,U,C,E,K,Z

## SPECIFICATIONS

<b>Type</b>	Stereo cassette tape deck
<b>Track format</b>	4 tracks, 2 channels
<b>Power supply</b>	AD-F800E, Z AC 220 V, 50/60 Hz AD-F800K AC 240 V, 50/60 Hz AD-F800U, C AC 120 V, 60 Hz AD-F800H AC 120 V/220 V/240 V switchable, 50/60 Hz
<b>Power consumption</b>	19 W
<b>Frequency response</b>	METAL tape: 10-20,000 Hz CrO <sub>2</sub> tape: 10-19,000 Hz NORMAL tape: 10-18,000 Hz
<b>Signal-to-noise ratio</b>	80 dB (METAL tape DOLBY C NR ON above 5 kHz)
<b>Wow and flutter</b>	0.065% (according to DIN 45500) 0.035% (WRMS)
<b>Tape speed</b>	4.8 cm/sec. (1 <sup>7</sup> / <sub>8</sub> ips)
<b>Recording system</b>	AC bias (frequency 85 kHz)
<b>Erase system</b>	AC erase
<b>Motor</b>	DC servomotor × 1 DC motor × 1

<b>Heads</b>	Playback head × 1 (PC-OCC coil super DX head) Recording head × 1 (PC-OCC coil super DX head) Erase head × 1 (Double-gap sendust head)
<b>Inputs</b>	REC/LINE IN, CD/DAT DIRECT IN maximum input sensitivity: 50 mV (47 k $\Omega$ )
<b>Outputs</b>	PLAY/LINE OUT standard output level: 450 mV (0 VU); suitable load impedance: over 50 k $\Omega$ PHONES: 1.5 mW (32 $\Omega$ )
<b>Dimensions</b>	430(W) × 141(H) × 317(D) mm
<b>Weight</b>	5.1 kg

- Design and specifications are subject to change without notice.
- Dolby noise reduction and HX Pro headroom extension manufactured under license from Dolby Laboratories Licensing Corporation. HX Pro originated by Bang & Olufsen.
- "Dolby", the double-D symbol  $\square\square$  and "HX PRO" are trademarks of Dolby Laboratories Licensing Corporation.

AIWA Co., Ltd.

Tokyo Japan

Printed in Japan

IC BLOCK DIAGRAM

IC, CX20187

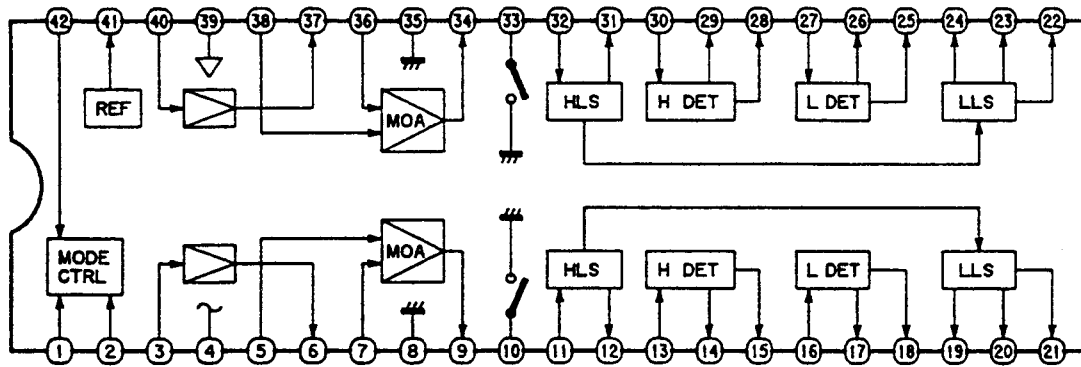

IC, BA6146

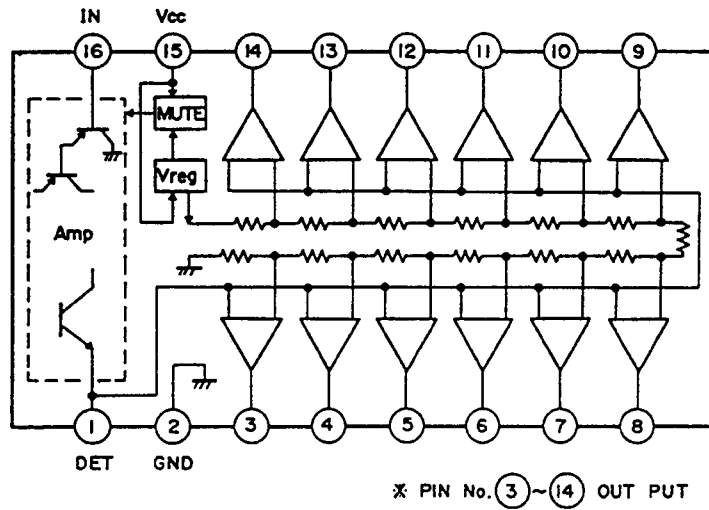

ACCESSORIES/PACKAGE LIST

PART NO. CHANGED TO	REF. NO.	PART NO.	DESCRIPTION	COMMON MODEL	Q'TY
	1	★84-793-901-010	INSTRUCTION BOOKLET	※	1
	2	★87-032-845-010	SIEMENS PLUG (H)		1
	3	★87-034-773-010	CORD PIN, R-237W-1M		2

# ELECTRICAL MAIN PARTS LIST

REF. NO.	PART NO.	DESCRIPTION
===IC===		
	87-020-504-010	IC, AN79M07
	87-020-180-010	IC, BA6146
	87-001-143-010	IC, CX20187
	87-020-111-010	IC, L78M05
	87-001-518-010	IC, L78M07ML
	84-793-613-010	IC, LC6512A-4115
	87-001-127-010	IC, M5218P
	87-001-383-010	IC, M5220P
	87-027-909-010	IC, M54523P
	87-027-986-010	IC, NJM4560S
	87-027-937-010	IC, TC4030BP
===TRANSISTOR===		
	89-110-155-010	TRANSISTOR, 2SA1015GR
	89-108-854-010	TRANSISTOR, 2SA885RS
	89-109-521-010	TRANSISTOR, 2SA952K
	89-318-155-010	TRANSISTOR, 2SC1815GR
	89-320-011-010	TRANSISTOR, 2SC2001K
	89-321-204-010	TRANSISTOR, 2SC2120Y
	89-412-753-010	TRANSISTOR, 2SD1275
	89-413-023-010	TRANSISTOR, 2SD1302S
===DIODE===		
	87-027-815-010	DIODE 1B4B1 LC-2
	87-020-110-010	DIODE 1S5177
	87-020-123-010	DIODE DS446
	87-027-365-010	DIODE S5277B
	82-001-187-010	DIODE S5277B LC6
	87-027-347-010	DIODE, ZENER HZ182LT2
	87-027-702-010	DIODE, ZENER HZ6C2L
===MAIN CIRCUIT BOARD SECTION===		
C103	*87-014-049-010	CAP, PP 470P
C104	*87-014-049-010	CAP, PP 470P
C105	*87-014-119-010	CAP, PP 0.027G
C106	*87-014-119-010	CAP, PP 0.027G
C107	*87-010-402-010	CAP, ELECT 2.2-50V SME
C108	*87-010-402-010	CAP, ELECT 2.2-50V SME
C109	*87-010-402-010	CAP, ELECT 2.2-50V SME
C110	*87-010-402-010	CAP, ELECT 2.2-50V SME
C111	*87-010-263-010	CAP, ELECT 100-10V
C112	*87-010-263-010	CAP, ELECT 100-10V
C115	*87-018-125-010	CAP, CERA 330P
C116	*87-018-125-010	CAP, CERA 330P
C119	*87-018-121-010	CAP, CERA 150P
C120	*87-018-121-010	CAP, CERA 150P
C121	*87-014-114-010	CAP, PP 4700PG
C122	*87-014-114-010	CAP, PP 4700PG
C135	*87-014-116-010	CAP, PP 6800PG
C136	*87-014-116-010	CAP, PP 6800PG
C139	*87-010-134-010	CAP, ELECT 4.7-35V BP
C140	*87-010-134-010	CAP, ELECT 4.7-35V BP
C141	*87-018-131-010	CAP, CERA 1000P
C142	*87-018-131-010	CAP, CERA 1000P
C145	*87-010-402-010	CAP, ELECT 2.2-50V SME
C146	*87-010-402-010	CAP, ELECT 2.2-50V SME
C147	*87-018-119-010	CAP, CERA 100P
C148	*87-018-119-010	CAP, CERA 100P
C217	*87-010-382-010	CAP, ELECT 22-25V SME
C218	*87-010-382-010	CAP, ELECT 22-25V SME
C221	*87-010-404-010	CAP, ELECT 4.7-50V SME
C222	*87-010-404-010	CAP, ELECT 4.7-50V SME
C223	*87-010-134-010	CAP, ELECT 4.7-35V BP
C224	*87-010-134-010	CAP, ELECT 4.7-35V BP
C225	*87-015-141-010	CAP, ELECT 10-16V BP
C226	*87-015-141-010	CAP, ELECT 10-16V BP
C229	*87-014-114-010	CAP, PP 4700PG

REF. NO.	PART NO.	DESCRIPTION
C230	*87-014-114-010	CAP, PP 4700PG
C243	*87-014-116-010	CAP, PP 6800PG
C244	*87-014-116-010	CAP, PP 6800PG
C247	*87-010-134-010	CAP, ELECT 4.7-35V BP
C248	*87-010-134-010	CAP, ELECT 4.7-35V BP
C301	*87-014-159-010	CAP, PP 0.012
C302	*87-018-134-010	CAP, CERA 0.01
C305	*87-010-138-010	CAP, ELECT 22-25 BP
C306	*87-010-132-010	CAP, ELECT 1-50V BP
C308	*87-010-101-010	CAP, ELECT 220-16V SME
C309	*87-010-405-010	CAP, ELECT 10-50V SME
C311	*87-014-041-010	CAP, PP 220P
C312	*87-014-041-010	CAP, PP 220P
C313	*87-014-131-010	CAP, PP 1800P
C314	*87-014-131-010	CAP, PP 1800P
C321	*87-018-131-010	CAP, CERA 1000P
C322	*87-018-131-010	CAP, CERA 1000P
C329	*87-010-388-010	CAP, ELECT 1000-25V SME
C330	*87-010-389-010	CAP, ELECT 2200-25V SME
C331	*87-010-389-010	CAP, ELECT 2200-25V SME
C332	*87-010-697-010	CAP, ELECT 220-16V AWD
C333	*87-010-697-010	CAP, ELECT 220-16V AWD
C334	*87-010-401-010	CAP, ELECT 1-50V SME
C335	*87-010-247-010	CAP, ELECT 100-50V SME
C336	*87-010-263-010	CAP, ELECT 100-10V
C337	*87-010-408-010	CAP, ELECT 47-50V
C338	*87-010-260-010	CAP, ELECT 47-25V SME
C339	*87-010-263-010	CAP, ELECT 100-10V
C340	*87-010-401-010	CAP, ELECT 1-50V SME
C341	*87-010-237-010	CAP, ELECT 1000-16 SME
C342	*87-010-383-010	CAP, ELECT 33-25V SME
C344	*87-010-260-010	CAP, ELECT 47-25V SME
C345	*87-010-260-010	CAP, ELECT 47-25V SME
C346	*87-018-134-010	CAP, CERA 0.01
C401	*87-018-132-010	CAP, CERA 2200P
C402	*87-010-382-010	CAP, ELECT 22-25V SME
C403	*87-010-382-010	CAP, ELECT 22-25V SME
C404	*87-010-384-010	CAP, ELECT 100-25V SME
ΔFR1	87-029-008-010	RES, FUSE 1/4W 10
ΔFR2	87-029-108-010	RES, FUSE 1/2W 1
ΔFR3	87-029-082-010	RES, FUSE 1/4W 100
ΔFR4	87-029-082-010	RES, FUSE 1/4W 100
ΔFR6	87-029-380-010	RES, FUSE 1/4W 33
J1	87-009-043-010	JACK, 6.3 (PHONES)
J2	*87-009-161-010	JACK, PIN 6P(PLAY/LINE OUT) (REC/LINE IN)(CD/DAT DIRECT)
L1	*82-190-629-010	FILTER, LP, 85K-2
L3	*82-221-697-010	FILTER, SQ CX
L4	*82-221-697-010	FILTER, SQ CX
L5	*82-135-631-010	FILTER, TRAP 85K
L6	*82-135-631-010	FILTER, TRAP 85K
L9	*82-132-631-010	COIL, 4.7MHH J
L10	*82-132-631-010	COIL, 4.7MHH J
L11	*82-231-624-010	FILTER
L12	*82-231-624-010	FILTER
L13	*82-221-697-010	FILTER, SQ CX
L14	*82-221-697-010	FILTER, SQ CX
L15	*82-100-620-010	COIL, OSC 85K S
L16	*87-003-051-010	COIL, 470UH
L17	*82-132-643-010	COIL, OSC 85K-HX
L18	*82-132-643-010	COIL, OSC 85K-HX
L19	*87-003-051-010	COIL, 470UH
S1	82-100-632-010	PUSH SW (MONITOR)
S2	82-100-631-010	PUSH SW (MPX FILTER)
S4	84-794-624-010	PUSH SW (CD/DAT DIRECT)
SFR1	*87-024-175-010	SFR, 47K
SFR2	*87-024-175-010	SFR, 47K
SFR3	*87-024-174-010	SFR, 33K

REF. NO.	PART NO.	DESCRIPTION
SFR4	*87-024-174-010	SFR, 33K
SFR5	*87-024-177-010	SFR, 220K
SFR6	*87-024-177-010	SFR, 220K
VR1	84-794-625-010	VR, 50KA (LEVEL)

REF. NO.	PART NO.	DESCRIPTION
S22	81-505-601-010	LEAF SW GEARCAM (PAUSE)

===FRONT CIRCUIT BOARD SECTION===

C501	*87-010-265-010	CAP, ELECT 33-16V SME
C502	*87-010-265-010	CAP, ELECT 33-16V SME
D30	82-234-620-010	LED, SLZ981C50, R, L105 (REC)
D31	82-234-620-010	LED, SLZ981C50, R, L105 (REC MUTE)
D32	82-234-607-010	LED, SLZ481C50, Y, L105 (PAUSE)
D33	84-793-615-010	LED, SLZ381C50, G, L45 (PLAY)
D34	87-020-736-010	LED, SLP-255B-40 (TAPE)
D35	87-001-789-010	LED, SLP-455B-51 (SOURCE)
D36	87-020-736-010	LED, SLP-255B-40 (B)
D37	87-020-246-010	LED, SLP-155B-40 (C)
FL1	82-234-631-010	FL, 8D-3(TAPE COUNTER, PEAK LEVEL)
R534	82-234-648-010	RES, ARRAY 47KX6
R535	82-234-647-010	RES, ARRAY 47KX5
S4	87-031-771-010	TACT SW (REW/REVIEW)
S5	87-031-771-010	TACT SW (PLAY)
S6	87-031-771-010	TACT SW (STOP)
S7	87-031-771-010	TACT SW (F. FWD/CUE)
S8	87-031-771-010	TACT SW (PAUSE)
S9	87-031-771-010	TACT SW (REC)
S10	87-031-771-010	TACT SW (REC MUTE)
S11	87-036-087-010	SLIDE SW (TIMER)
S12	87-036-087-010	SLIDE SW (MEMORY)
S13	82-234-644-010	SLIDE SW (DOLBY NR)
S14	87-031-771-010	TACT SW (COUNTER RESET)
VIB1	87-030-183-010	CERAMIC RESONATOR
VR2	82-234-641-010	VR, 30KA (REC LEVEL)
VR3	84-793-606-010	VR, 5KX2 (REC LEVEL/CARIBRATION)
VR4	84-794-623-010	VR, 50KB (BIAS/CARIBRATION)



E C B



E C B

===SWITCH CIRCUIT BOARD SECTION===

△C343	87-019-113-010	CAP, SG 0.0022E
△S3	87-036-184-010	PUSH SW (POWER)

2SA1015

2SA885

===DECK CIRCUIT BOARD SECTION===

CP1	87-026-491-010	PHOTO SENSOR, SPI-315-04-B
M1	87-045-301-010	MOTOR (REEL)
S15	81-505-607-010	LEAF SW (REC EN)
S16	81-505-607-010	LEAF SW (CrO2)
S17	81-505-607-010	LEAF SW (METAL)
S18	81-505-607-010	LEAF SW (CASSETTE)
SOL1	81-507-237-010	SOLENOID, PME-C(PLAY)
SOL2	81-507-237-010	SOLENOID, PME-C(PAUSE)

2SA952

2SC1815

2SC2001

2SC2120

2SD1302

===POWER CIRCUIT BOARD SECTION===

△PT1	84-793-624-010	POWER TRANSFORMER E (E, Z)
△PT1	84-793-622-010	POWER TRANSFORMER H (H)
△PT1	84-793-625-010	POWER TRANSFORMER K (K)
△PT1	84-793-623-010	POWER TRANSFORMER U, C (L, P)
△S20	87-036-128-010	ROTARY SW (AC VOLTAGE) (H)

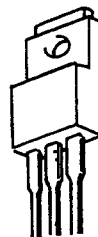

B C E

===MISCELLANEOUS===

△	87-034-736-010	AC CORD ASSY, (E, Z)
△	87-034-732-010	AC CORD ASSY, (H)
△	87-034-734-010	AC CORD ASSY, (K)
△	87-034-731-010	AC CORD ASSY, (U, C)
△	87-085-189-010	BUSHING, AC CORD (U, C)
△	87-085-184-010	BUSHING, AC CORD D (H)
△	87-085-185-010	BUSHING, AC CORD E (E, K, Z)
EH	87-046-288-010	EH HEAD

2SD1275

D17	87-020-109-010	LED, SLF-201C (CASSETTE)
M2	87-045-296-010	MOTOR (CAPSTAN)
RPH	87-046-313-010	HEAD COMB
S21	81-505-601-010	LEAF SW GEARCAM (PLAY)

BLOCK DIAGRAM

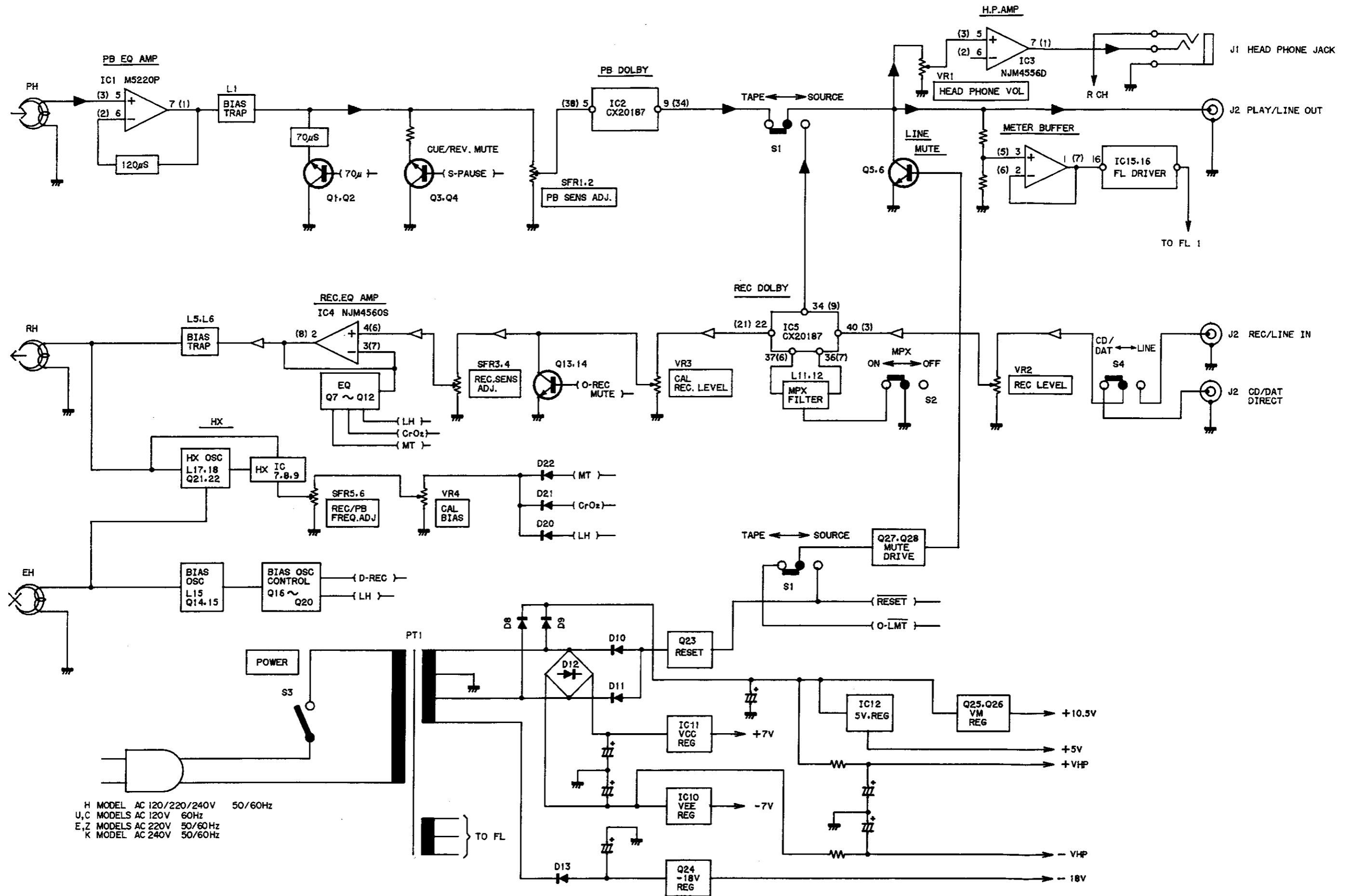

A  
B  
C  
D  
E  
F  
G  
H  
I  
J

A MAIN C.B

J2-3,2,4 REC./LINE IN  
J2-5,2,5 CD/DAT DIRECT.  
J2-1,2,2 PLAY/LINE OUT

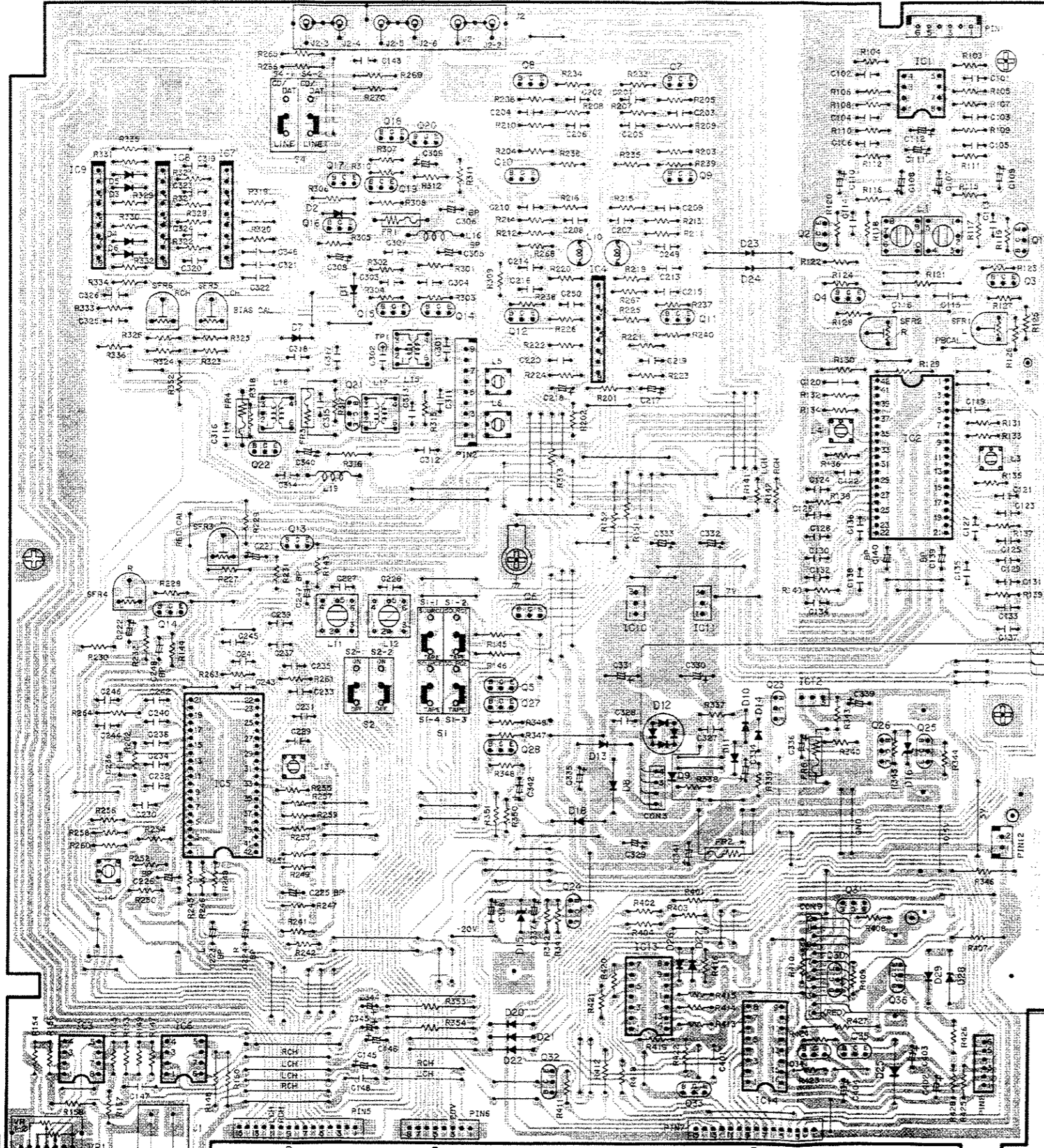

C SWITCH C.B

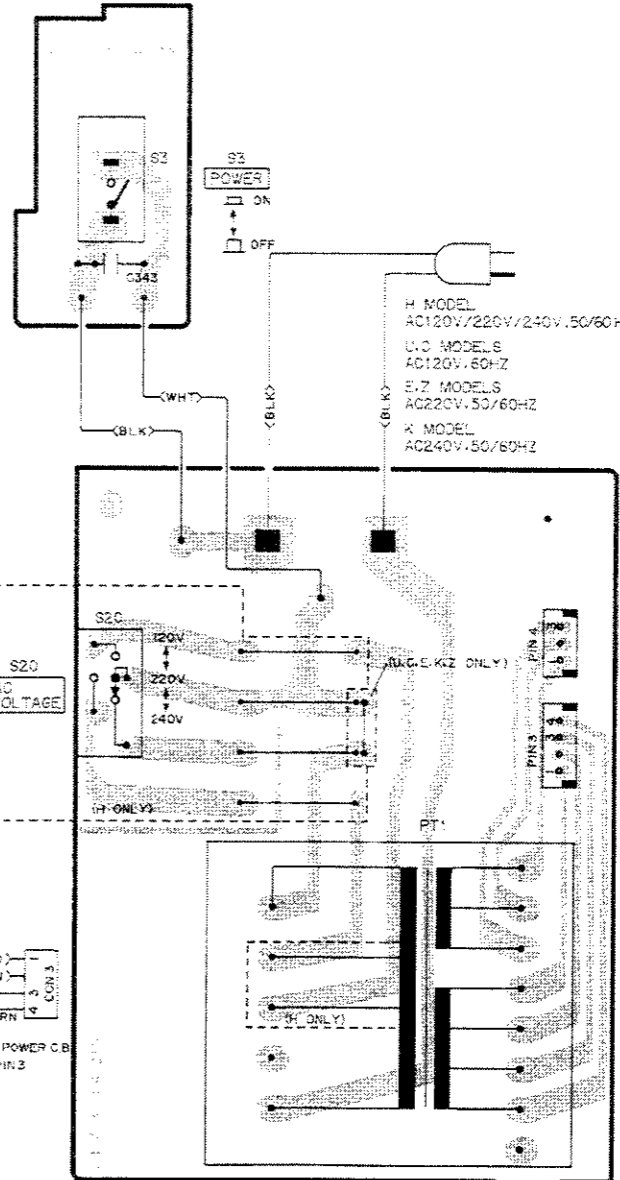

E POWER C.B

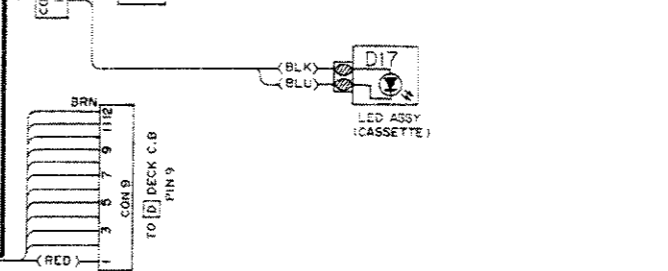

TO [A] MAIN C.B TO [B] FRONT C.B  
CON 3  
CON 4

TO [E] POWER C.B  
PIN 3  
CON 3

TO [D] DECK C.B  
PIN 9  
CON B  
CON A

TO [B] FRONT C.B CON 5  
TO [B] FRONT C.B CON 6  
TO [B] FRONT C.B CON 7

J1 PHONES  
S4 CD/DAT DIRECT.  
LINE  
S2 MPX FILTER  
ON  
OFF  
S1 MONITOR  
SOURCE  
TAPE

VR1 LEVEL

SCHEMATIC DIAGRAM - 1

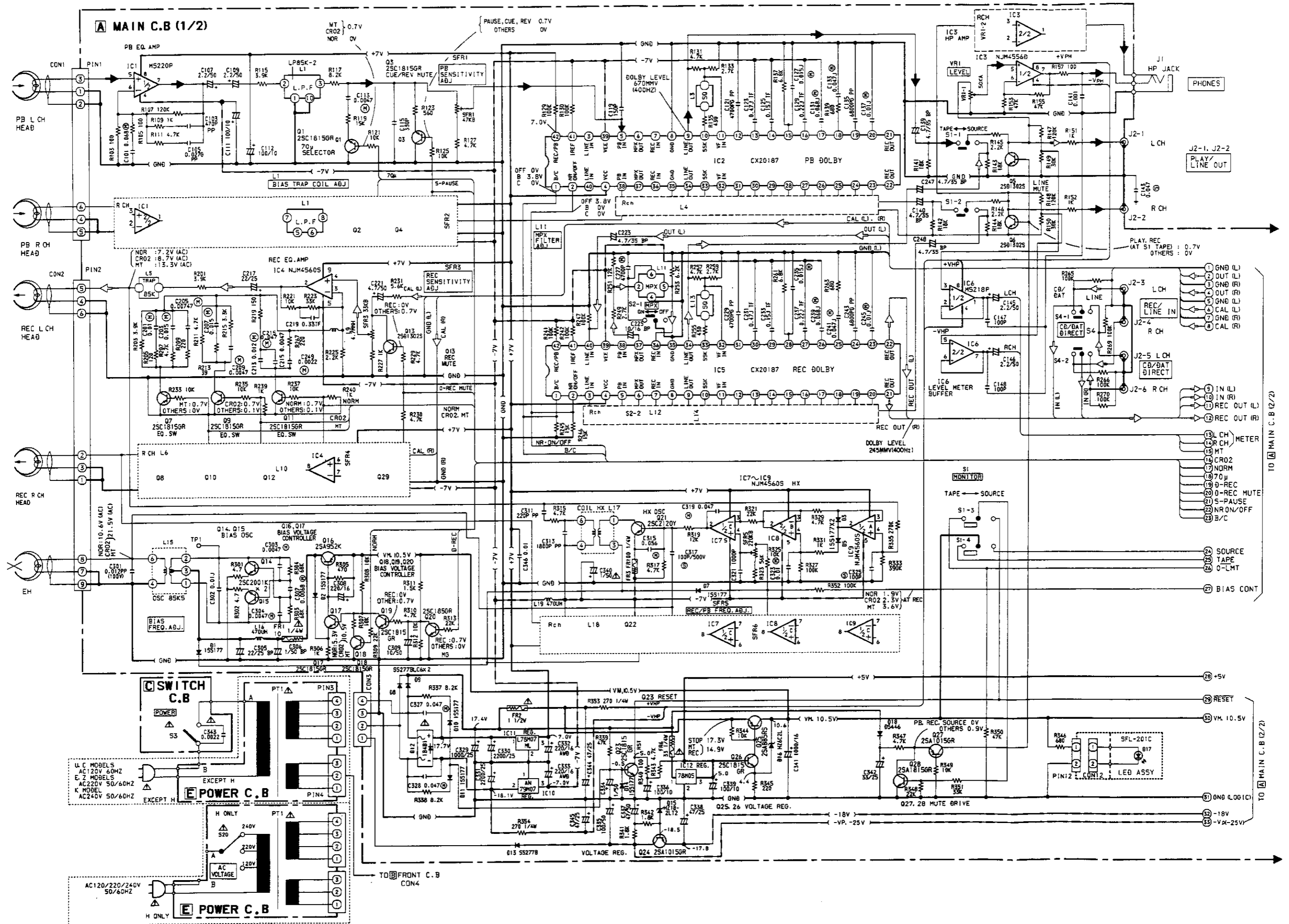



A  
B  
C  
D  
E  
F  
G  
H  
I  
J

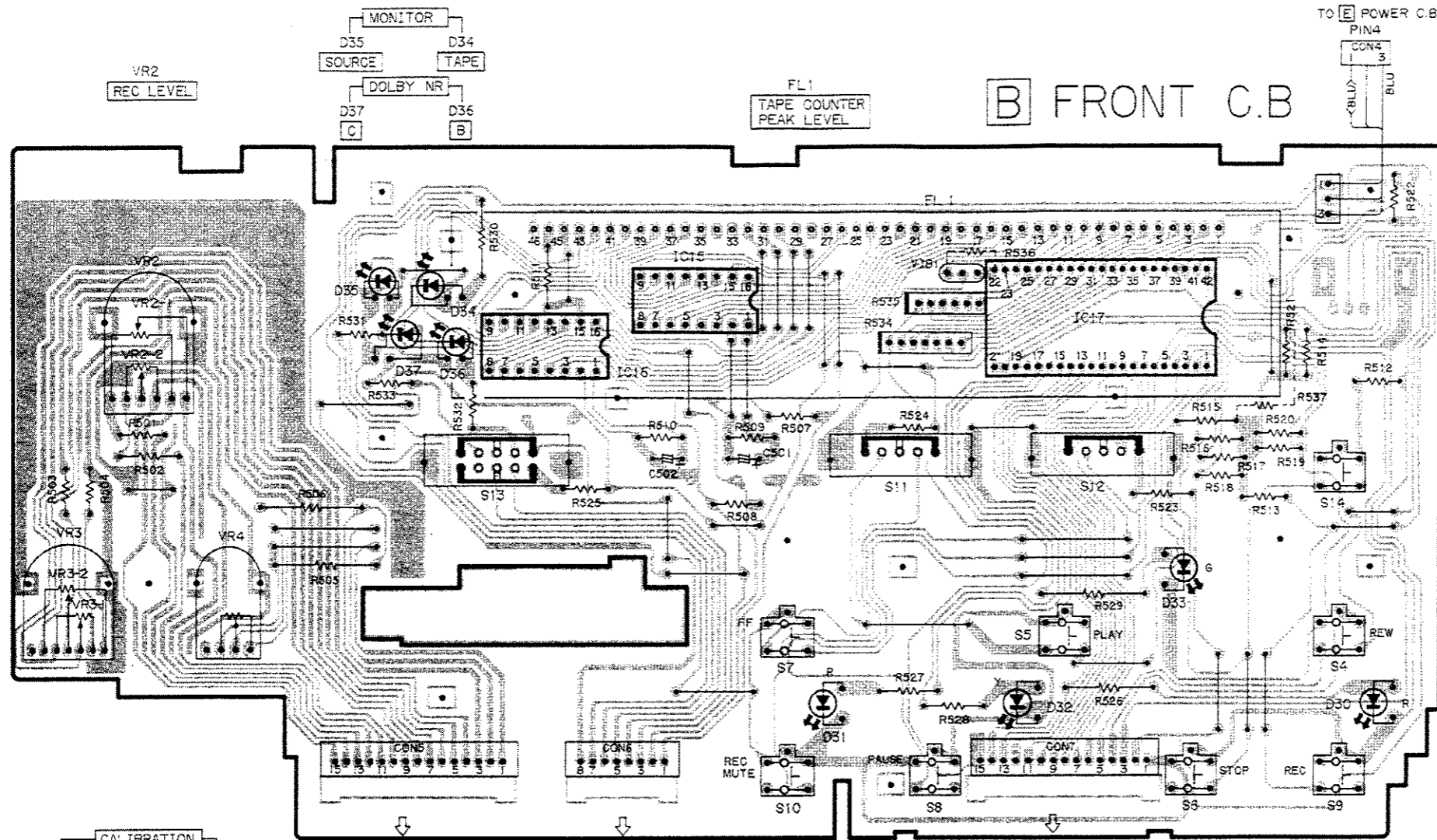

B FRONT C.B

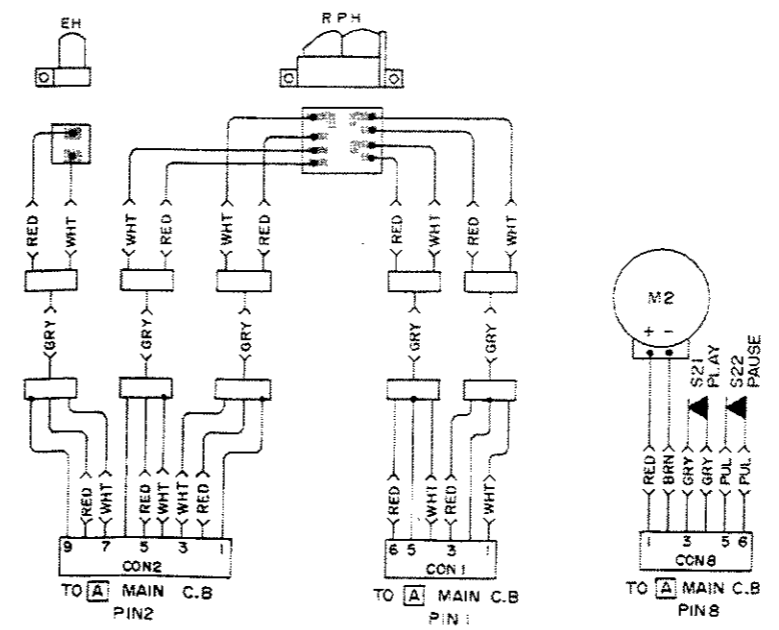
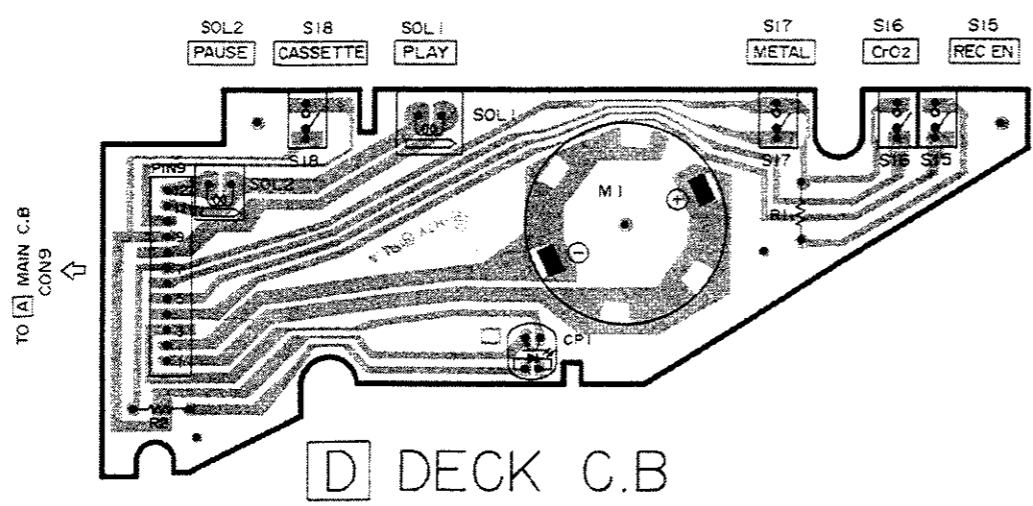
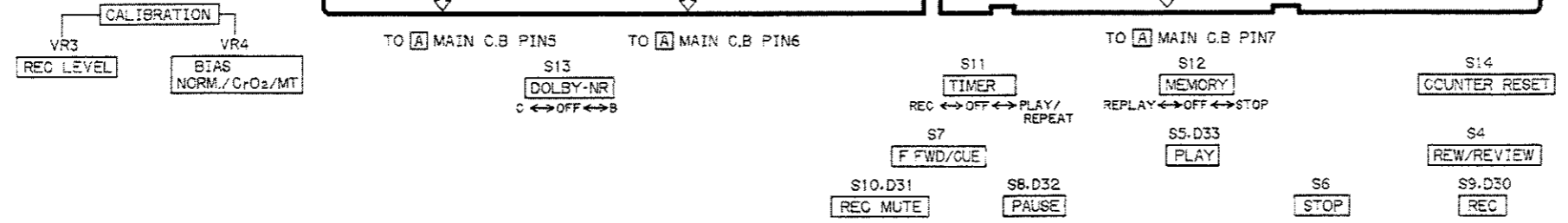



SCHEMATIC DIAGRAM - 2

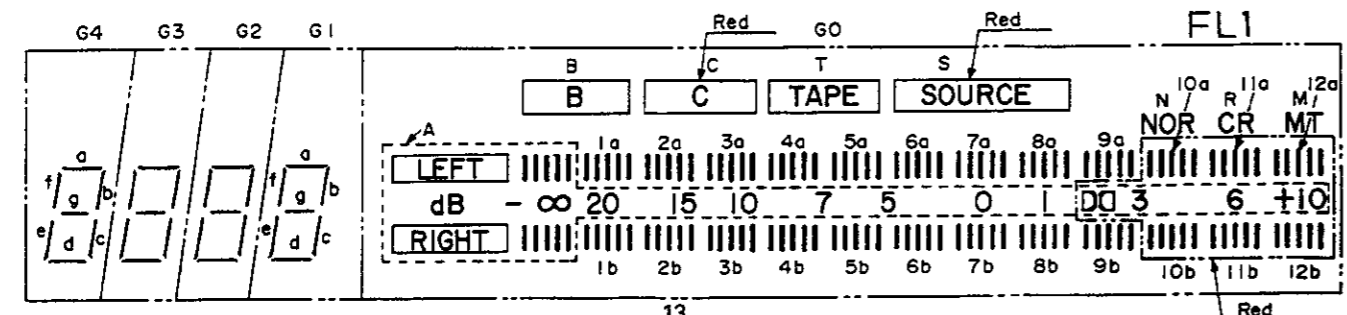
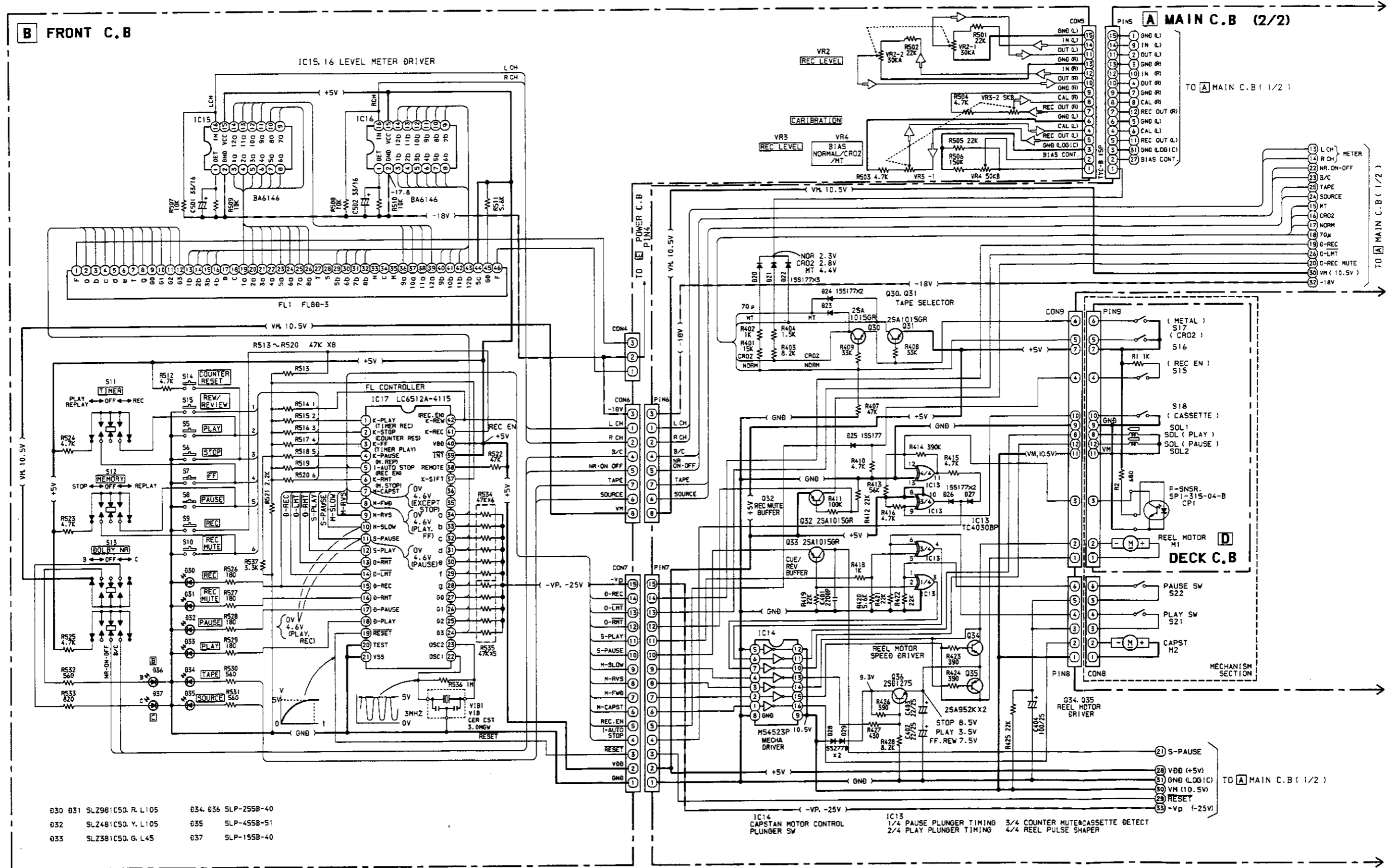

# ADJUSTMENT

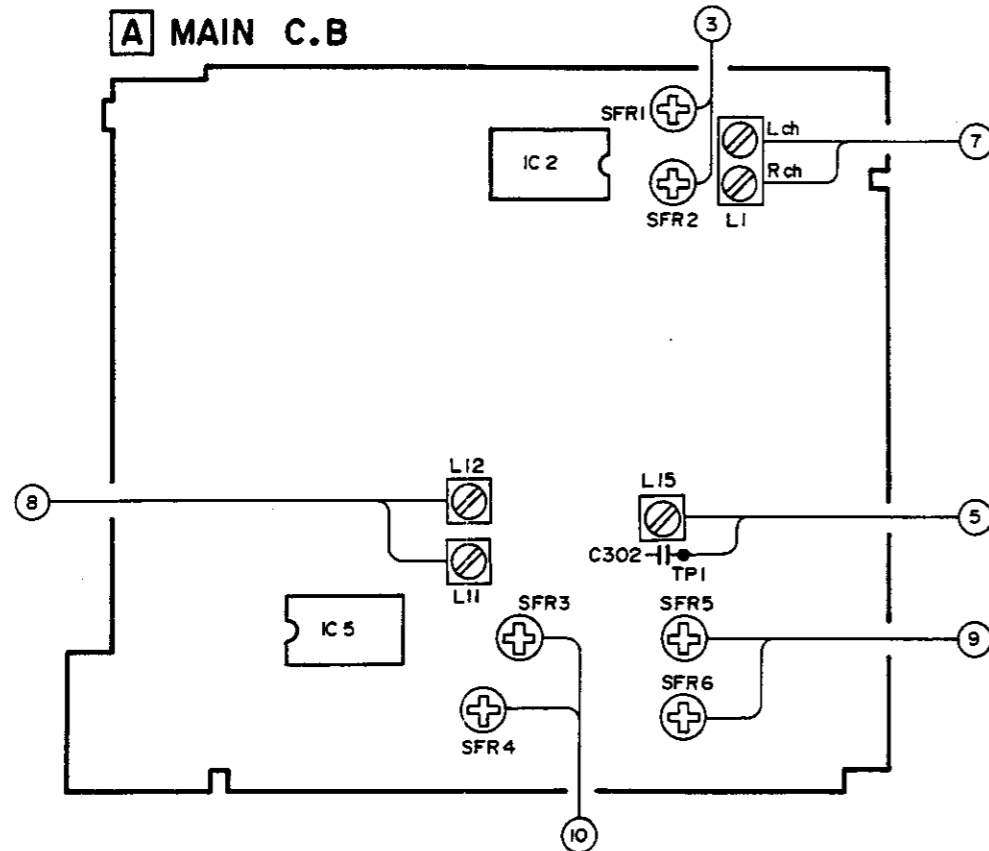
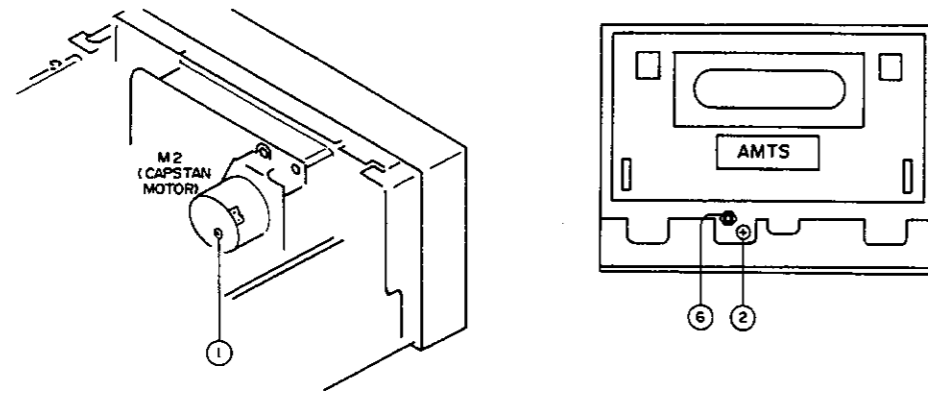

## Initial Settings

1. REC LEVEL : Mechanical center
2. BIAS FINE (CALIBRATION) : Center click position
3. REC LEVEL (CALIBRATION) : Center click position
4. MPX SELECTOR SW : THRU
5. MONITOR SELECTOR SW : THRU
6. DOLBY NR SW : THRU
7. REC VOLUME : Adjust the REC volume control in -16.0 dBV to set to 0VU, 460mV (source side).

## 1. Tape Speed Adjustment

- Settings : • Test tape : TTA-100 (TTA-111S)  
 • Test point : LINE OUT jack  
 • Adjustment location : SFR in Capstan motor. (M2)

Method : Playback the test tape and adjust so the frequency counter reads 3000Hz ± 10Hz.

## 2. Azimuth Adjustment

- Settings : • Test Tape : TTS-310 (TTS-317E, SCC-1429)  
 • Test point : LINE OUT jack  
 • Adjustment location : Azimuth adjustment screw

Method : Play the 10kHz signal of the test tape and adjust so the output is maximum and the waveforms in the Lissajours figure are in phase.

## 3. Playback Sensitivity Adjustment

- Settings : • Test tape : TTS-200 (TTA-161, TCC-130)  
 • Test Point : LINE OUT jack  
 • LEVEL meter : Dolby NR mark  
 • Adjustment location : SFR1 (L ch)  
 SFR2 (R ch)

Method : Playback the test tape and adjust so the output level is 640mV ± 20mV

## 4. Playback Frequency Response Check

- Settings : • Test tape : TTS-310 (TTA-317E, SCC-1429)  
 • Test point : LINE OUT jack

Method : Play the 1kHz and 10kHz signals of the test tape and check the output of the 10kHz signal is 0.5dB ± 2dB with respect to that of the 1kHz signal.

## 5. Bias OSC. Frequency Adjustment

- Settings : • Test tape : TTA-620 (TTA-119MP)  
 • Test points : TP1  
 • Adjustment location : L15

Method : Set to the record mode and adjust so the frequency counter reads 85kHz ± 1kHz.

## 6. Erase Head Height Position Adjustment

- Settings : • Test tape : TTA-620 (TTA-119MP)  
 TTA-600 (TTA-119K)  
 • Test point : LINE OUT jack  
 • Adjustment location : Hexagonal nut of erase head

Method : Record a 125Hz ± 10VU signal on test tape TTA-620 (TTA-119MP) using this unit. Rewind the recorded section and set to the erase state. Turn the hexagonal nut gradually clockwise and check that 125Hz waveform appears at the R ch playback is minimum, then turn a further half turn counterclockwise.

## (Over-erase check)

Play test tape TTA-600 (TTA-119K) and let the R ch output be the reference output. Then turn over TTA-600 (TTA-119K) and set to the erase state.

Turn over the tape again and play the erased section in the reverse side and check that the difference from the reference R ch output is within 1.5dB.

## 7. Bias Trap Coil Adjustment

- Settings : • Test tape : TTA-620 (TTA-119MP)  
 • Test point : LINE OUT jack  
 • Adjustment locations : L1 (L ch)  
 L1 (R ch)

Method : Set to the record mode and adjust so the bias voltage leaking to the test point is minimum level.

## 8. MPX Filter Adjustment

- Settings : • Test tape : Blank Tape  
 • Test point : LINE OUT jack  
 • Adjustment locations : L11 (L ch)  
 L12 (R ch)  
 • Input signal : 19kHz signal (0VU) at input  
 • MPX SW : ON

Method : Record the test tape and adjust so that the output DOLBY NR SW ON becomes up to -30dB for the output at DOLBY NR SW OFF.

## 9. Recording/Playback Frequency Response Adjustment

- Settings : • Test tape : TTA-600 (TTA-119K) (LH)  
 TTA-610 (TTA-119H) (CrO2)  
 TTA-620 (TTA-119MP) (MT)  
 • Input signal : 1kHz/10kHz (LINE IN)  
 • Test point : LINE OUT jack  
 • Adjustment locations : SFR5 (L ch)  
 SFR6 (R ch)

Method : Apply a 1kHz signal and adjust the attenuator so the output level at the LINE OUT jack is 46mV. Record and playback the 1kHz and 10kHz signals and adjust so the output difference (LH tape mode), 0dB ± 1dB (CrO2, MT tape mode).

## 10. Recording Sensitivity Adjustment

- Settings : • Test tape : TTA-600 (TTA-119K) (LH)  
 TTA-610 (TTA-119H) (CrO2)  
 TTA-620 (TTA-119MP) (MT)  
 • Input signal : 1kHz (-20VU) (LINE IN)  
 • Test point : LINE OUT jack  
 • Adjustment locations : SFR3 (L ch)  
 SFR4 (R ch)

Method : Apply a 1kHz signal and adjust the attenuator so the output level at the LINE OUT jack is 0 VU.

Record and playback the 1kHz signal and adjust so the output is 46mV ± 2mV (LH tape mode), 46mV ± 5mV (CrO2, MT tape mode).

## PRACTICAL SERVICE FIGURE

Playback output:	640 ± 50mV (LINE OUT) More than 0.6mW (PHONES, LOAD 32 OHMS, 1kHz, 0VU)
PB/REC output:	460 ± 50mV (LINE OUT)
PB/REC distortion:	Less than 1.5% (MT, TTA-620, CrO2, TTA-610, NORM., TTA-600)
Playback noise:	Less than 3.0/1.2mV (MT, TTA-620 CrO2, TTA-610, DOLBY NR C OFF/ON) Less than 4.0/1.4mV (NORM., TTA-600 DOLBY NR C OFF/ON)
PB/REC noise:	Less than 3.2/1.3mV (MT, TTA-620, CrO2, TTA-610, DOLBY NR C OFF/ON) Less than 4.3/1.5mV (NORM., TTA-600 DOLBY NR C OFF/ON)
Erase Ratio (125Hz):	More than 60dB
Crosstalk:	More than 60dB (1kHz, 0VU)
Channel separation:	More than 30dB (1kHz, 0VU)
Recording bias frequency:	85kHz
Tape speed	
TTA-100 (TTA-111S) :	3,000Hz ± 1.5%
Wow & flutter:	Less than 0.042% (JIS/WRMS, PB)
Take-up torque:	45 ± 10g-cm
Fast forward torque:	90 ~ 190g-cm
Rewind torque:	90 ~ 190g-cm
Back-tension:	7 ± 2.5g-cm
Test tapes:	METAL TTA-620 (TTA-119MP) CrO2 TTA-610 (TTA-119H) NORMAL TTA-600 (TTA-119K)

IC DESCRIPTION

IC, LC6512A-4115

Pin No.	Pin name	I/O	Description	
			K-SIFT is High	K-SIFT is Low
42	K-REW/ K-REC EN.	I	REW key input (active when Low.)	REC EN key input (active when High). (Can be recorded when High.)
41	K-REC/ K-CST	I	REC key input (active when Low).	Cassette switch input (active when High). (Set high when there is a cassette.)
1	K-PLAY/ K-TIM-REC	I	PLAY key input (active when Low).	TIMER REC input (active when High).
2	K-STOP/ K-CNT-RES	I	STOP key input (active when Low).	Counter reset input (active when High).
3	K-FF/ K-TIM-PLY	I	FF key input (active when Low).	TIMER PLAY/input (active when High).
4	K-PAUSE/ K-M-REP	I	PAUSE key input (active when Low).	Counter "0000" replay input (active when High).
5	I-AUTO STOP REC EN.	I	Take-up reel rotation pulse. Auto stop, FL counter, and tape slack removal controls.	
6	K-RMT/ K-M-STP	I	REC MUTE key input (active when Low).	Counter "0000" stop input (active when High).
7	M-CAPST	I	Capstan motor control input. Motor rotates when High.	
8	M-FWD	O	Sub-motor forward-direction rotation output. High in PLAY/REC, FF, and CUE modes.	
9	M-RVS	O	Sub-motor reverse-direction rotation output. High in REW/REV mode.	
10	M-SLOW	O	Reel motor voltage-controlled output. High in PLAY and REC/PB modes.	
11	S-PAUSE	O	Pause plunger output. High in PAUSE, PLAY PAUSE, R/P PAUSE, FF, REW, CUE, and REV modes.	
12	S-PLAY	O	Playback plunger output. High in PLAY, PLAY PAUSE, R/P PAUSE, CUE, and REV modes.	
13	O-RMT	O	Recording mute output. High when the set is stabilized in REC/PLAY mode.	
14	O-LMT	O	Playback mute output. High when the set is stabilized in PLAY, REC/PLAY, CUE, and REV modes.	
15	D-REC	O	Recording LED output. Also used for 0-REC. High in REC, REC/PLAY, REC/PLAY-PAUSE, REC/PAUSE, REC/PLAY/REC MUTE modes.	
16	D-RMT	O	Recording mute LED output. High in REC/PLAY mute modes. When the RMT key continuously pressed for more than 4 sec, set high every second.	
17	D-PAUSE	O	Pause LED output. High in PAUSE, R/P PAUSE, and PLAY/PAUSE modes. Repeatedly set high or low for 4 sec after power is turned on.	
18	D-PLAY	O	Playback LED output. High in PLAY, REC/PLAY, PLAY/PAUSE and R/P PAUSE modes.	
19	RESET	I	Microcomputer reset input. Gradually changes from 0V to +5V within 3 sec after power is turned on.	

Pin No.	Pin name	I/O	Description
20	TEST	-	Connected to GND.
21	V <sub>SS</sub>	-	
22	OSC 1	I	Microcomputer clock input (3MHz).
23	OSC 2	I	
24 } 27	G3 } G0	O } O	FL counter grid 3 and digit scan output. 1's digit. } FL counter grid 0 and digit scan output. 1,000's digit.
28 } 34	SEG g } SEG a	O } O	FL segment output g. } FL segment output a.
35	NC	-	---
36	NC	-	---
37	K-SIFT	I	Selection key input when High or Low.
38	REMOTE	I	Connected to +5V.
39	TNT	-	
40	V <sub>DD</sub>	-	

EXPLODED VIEW - 1

REF. NO.	PART NO.	DESCRIPTION
A	87-067-660-01	BVT 2+3-8W/O SLOT (B)
B	87-067-579-01	BVT 2+3-8W/O SLOT
C	87-067-688-01	BVTT+3-6
D	87-761-096-41	VFT 2+3-10
E	87-591-094-41	QIT+3-6
F	87-067-566-01	VFTT+3-6
G	87-067-581-01	BVT 2+3-15
H	87-067-633-01	BVT 2+3-8 CONVEX
I	87-067-689-01	BVTT+3-8
J	87-761-099-41	VFT 2+3-15

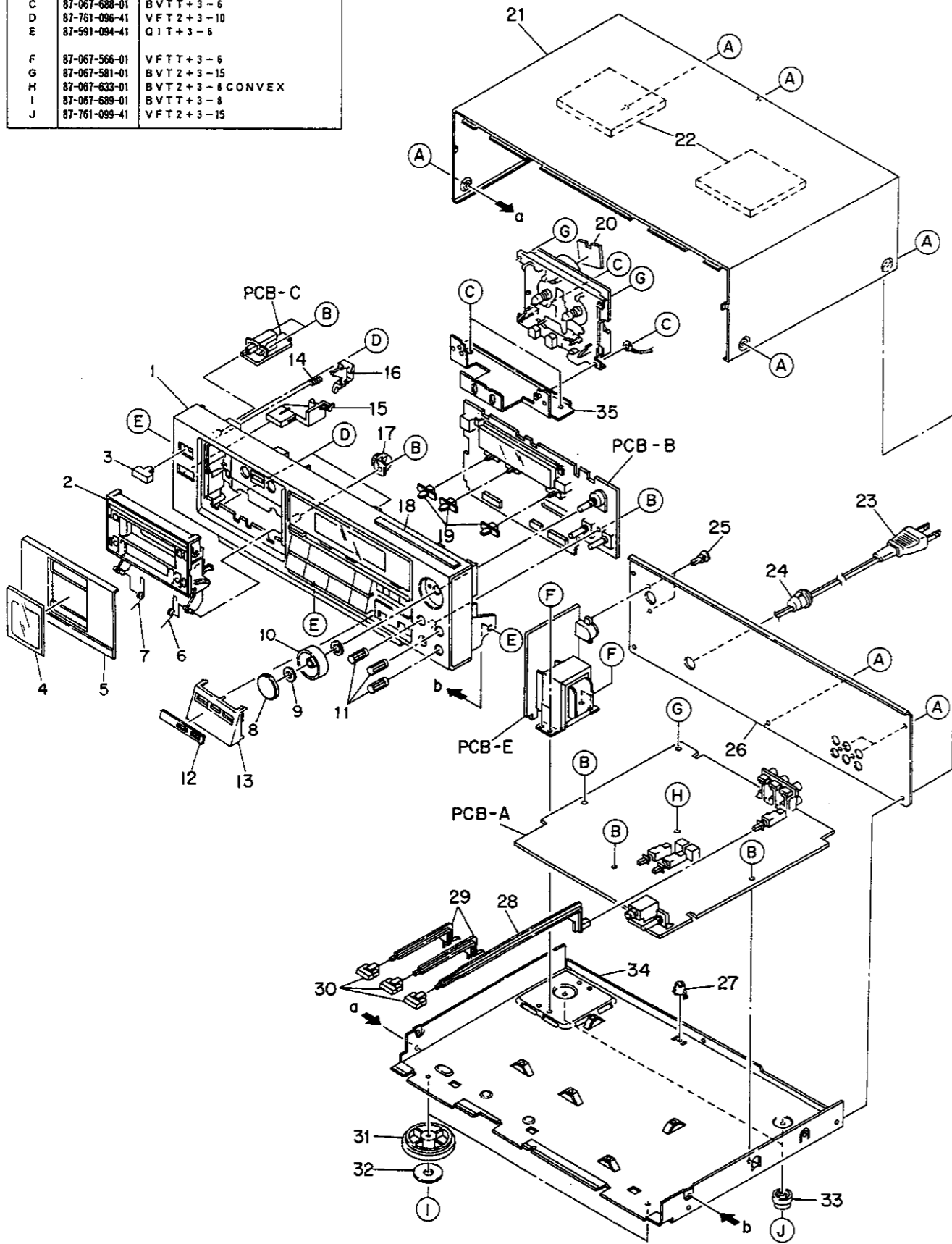

MECHANICAL PARTS LIST

PART NO.	REF. NO.	PART NO.	DESCRIPTION	COMMON MODEL	QTY
---	1-1	★09-047-522-010	CABINET FRONT ASSY (H, C, E, K, Z)	※	1
---	1-1	★09-047-523-010	CABINET FRONT ASSY (U)	※	1
---	1-2	★09-047-524-010	CASSETTE BOX ASSY (H, C, E, K, Z)	※	1
---	1-2	★09-047-525-010	CASSETTE BOX ASSY (U)	※	1
---	1-3	★84-721-023-010	BUTTON, POWER	※	1
---	1-4	★84-793-019-010	WINDOW, CHASSIS	※	1
---	1-5	★84-793-018-010	PANEL, CHASSIS	※	1
---	1-6	★84-793-213-010	T-SPRING, EJECT 2	※	1
---	1-7	★84-793-206-010	T-SPRING, EJECT	※	1
---	1-8	★82-234-020-010	KNOB, VOLUME R	※	1
---	1-9	★82-234-243-010	FELT, VOLUME	※	1
---	1-10	★82-234-019-010	KNOB, VOLUME L	※	1
---	1-11	★82-234-018-010	KNOB, BIAS	※	3
---	1-12	★84-793-013-010	KEY, STOP	※	1
---	1-13	★84-793-002-010	COVER, CABINET	※	1
---	1-14	★84-793-212-110	C-SPRING, EJECT	※	1
---	1-15	★84-793-011-010	BUTTON EJECT	※	1
---	1-16	★84-793-203-010	LEVER, EJECT	※	1
---	1-17	★87-063-143-010	OIL DAMPER 75	※	1
---	1-18	★84-793-031-010	SHEET, BIAS	※	1
---	1-19	★81-715-029-019	KNOB, SLIDE	※	3
---	1-20	★82-234-244-010	DAMPER, MOTOR	※	1
---	1-21	★84-793-026-010	CABINET, STEEL	※	1
---	1-22	★82-226-274-010	DAMPER, 80-60-3	※	2
---	1-23	★87-034-732-010	AC CORD (H)	※	1
---	1-23	★87-034-731-010	AC CORD (U, C)	※	1
---	1-23	★87-034-736-010	AC CORD (E, Z)	※	1
---	1-23	★87-034-734-010	AC CORD (K)	※	1
---	1-24	★87-085-184-010	AC CORD, BUSHING (H)	※	1
---	1-24	★87-085-189-010	AC CORD, BUSHING (U, C)	※	1
---	1-24	★87-085-185-010	AC CORD, BUSHING (E, K, Z)	※	1
---	1-25	★87-084-099-010	RIVET, NYLON 3-5.5SP (H)	※	2
---	1-26	★84-793-005-010	PANEL, REAR (H)	※	1
---	1-26	★84-793-006-010	PANEL, REAR (U)	※	1
---	1-26	★84-793-010-010	PANEL, REAR (C)	※	1
---	1-26	★84-793-007-110	PANEL, REAR (E)	※	1
---	1-26	★84-793-008-010	PANEL, REAR (K)	※	1
---	1-26	★84-793-009-010	PANEL, REAR (Z)	※	1
---	1-27	★81-664-202-010	HOLDER, PCB	※	1
---	1-28	★84-793-205-010	ROD CD DAT	※	1
---	1-29	★82-792-208-010	ROD A	※	2
---	1-30	★84-793-014-010	BUTTON, SHIFT	※	3
---	1-31	★84-738-022-010	FOOT	※	2
---	1-32	★84-731-027-010	FELT, FOOT	※	2
---	1-33	★84-793-027-010	FOOT, H14	※	2
---	1-34	---	CHASSIS, AMP	---	1
---	1-35	---	HOLDER, MECHANISM	---	1

EXPLODED VIEW - 2

REF. NO.	PART NO.	DESCRIPTION
A	87-261-036-01	V+2-8
B	87-081-543-01	U+2-9
C	87-081-963-01	M2-3.5
D	87-251-034-21	U+2-5
E	87-263-033-01	V+2-4 (N1)
F	87-341-035-21	UT1+2-6
G	87-341-038-21	UT1+2-1.2
H	87-081-414-01	W2-6-0.4
I	87-081-944-01	PW1.5-3.5-0.5
J	87-391-106-01	N2-4-1.6
K	87-081-481-21	VTT+3-5
L	87-067-006-01	W2-5-0.2
M	87-081-808-01	PW1.7-3.5-0.25
N	87-067-170-01	PW2.65-4.7-0.5
O	82-416-358-01	PW2.5-6-0.5

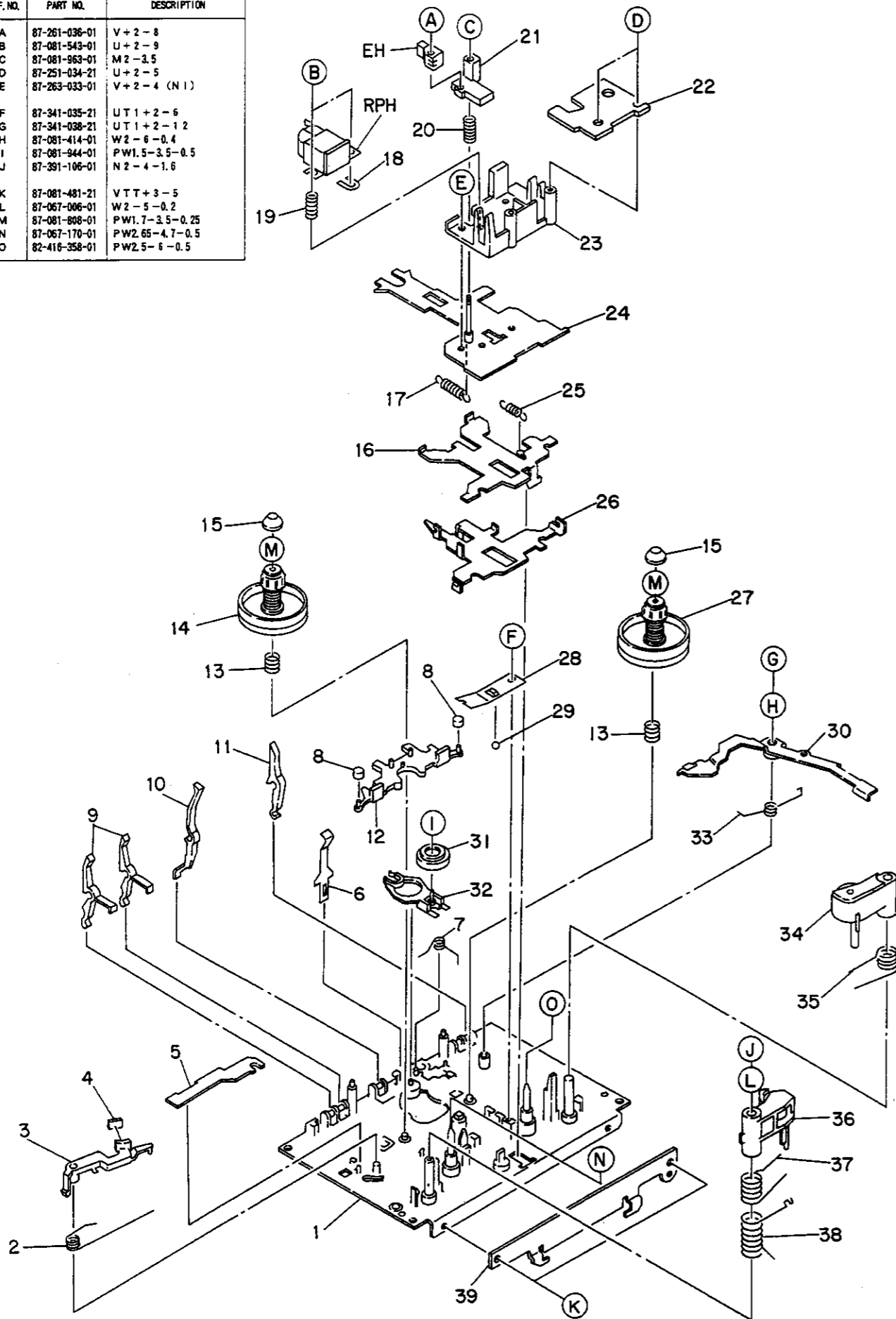

PART NO. CHANGED TO	REF. NO.	PART NO.	DESCRIPTION	COMMON MODEL	Q'TY
	2-1	★86-574-201-010	OUTSERT ASSY		1
	2-2	★81-507-223-010	T-SPRING, B. T		1
	2-3	★81-507-222-010	BACK TENSION LEVER		1
	2-4	★86-574-225-010	FELT 2.5-6-1		1
	2-5	★81-505-238-010	PLATE, EJECT BLOCKING		1
	2-6	★86-574-216-010	P-SPRING, CASSETTE		1
	2-7	★86-574-219-010	T-SPRING, IDLER		1
	2-8	★81-507-229-010	BRAKE G		2
	2-9	★81-505-241-210	CHROME LEVER REC BLOCKING		2
	2-10	★81-505-242-210	LEVER, METAL		1
	2-11	★81-505-240-210	LEVER, CASSETTE SENSOR		1
	2-12	★81-505-236-210	BRAKE SLIDE LEVER		1
	2-13	★81-507-219-010	C-SPRING, REEL S		2
	2-14	81-505-275-010	REEL S ASSY		1
	2-15	★82-303-398-010	CAP REEL PLATFORM		2
	2-16	★81-505-207-010	PAUSE PLATE		1
	2-17	★86-543-241-010	E-SPRING, SLIDE CHASSIS B		1
	2-18	★81-507-227-010	SPACER		3
	2-19	★86-543-224-010	C-SPRING, AZIMUTH		1
	2-20	★86-543-225-010	C-SPRING, EH		1
	2-21	★86-543-204-110	HOLDER, EH		1
	2-22	★82-226-211-010	COVER, HEAD		1
	2-23	★86-543-203-210	BASE, HEAD		1
	2-24	★86-574-203-110	HEAD CHASSIS ASSY		1
	2-25	★81-505-266-010	E-SPRING, PLATE PAUSE		1
	2-26	★81-507-220-010	PLATE, PINCH LEVER		1
	2-27	86-574-227-010	REEL TABLE T ASSY		1
	2-28	★81-507-224-010	P-SPRING, CHASSIS		1
	2-29	★87-073-005-010	STTEL BALL 2		1
	2-30	★81-505-307-210	LEVER, BRAKE EJECT C		1
	2-31	★81-505-251-110	FR SUB ASSY		1
	2-32	★86-574-208-010	LEVER FRP ASSY		1
	2-33	★86-574-218-010	T-SPRING, BRAKE		1
	2-34	81-505-210-210	PINCH LEVER F ASSY		1
	2-35	★81-505-267-010	T-SPRING, PINCH F		1
	2-36	81-507-207-310	PINCH LEVER S ASSY		1
	2-37	★86-543-257-010	T-SPRING, PINCH LEVER S		1
	2-38	★81-507-228-010	C-SPRING, PINCH LEVER S		1
	2-39	★86-543-231-110	HOLDER SLIDE CHASSIS		1

EXPLODED VIEW - 3

REF. NO.	PART NO.	DESCRIPTION
A	87-512-074-01	VFT,+2.6-8
B	87-081-484-01	PW3-6-0.25
C	87-261-072-21	V+2.6-5
D	81-505-341-01	VFT,+2.6-31.5

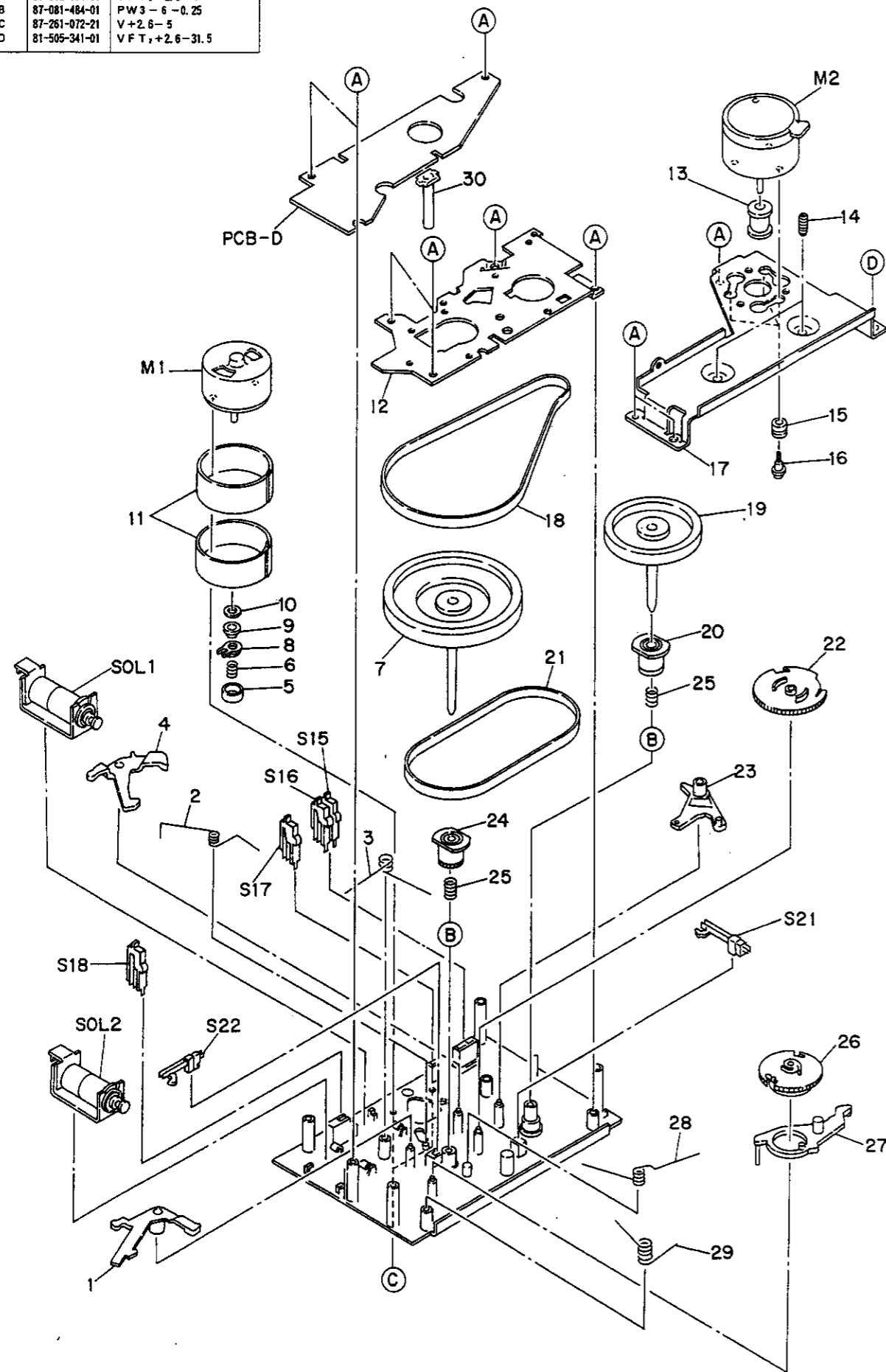

PART NO.  
CHANGED TO

REF. NO.	PART NO.	DESCRIPTION	COMMON MODEL	QTY
3-1	★81-505-233-010	PAUSE TRIGGER LEVER		1
3-2	★86-574-226-010	T-SPRING, PINCH PLATE		1
3-3	★81-505-271-110	T-SPRING, LEVER		1
3-4	★81-505-231-010	PLAY TRIGGER LEVER		1
3-5	★86-574-205-010	PULLEY, REEL MOTOR		1
3-6	★81-505-290-010	C-SPRING, FR IDLER C		1
3-7	86-574-212-010	FLYWHEEL S ASSY		1
3-8	★86-574-207-010	LEVER, CLUTCH		1
3-9	★86-574-211-010	FELT 3.8-7.6-0.8		1
3-10	★86-574-206-010	SPRING STOPPER		1
3-11	★81-505-606-010	SHIELD PLATE		2
3-12	★81-505-204-410	MECHANISM CHASSIS ASSY		1
3-13	★86-575-205-010	MAIN PULLEY MOTOR		1
3-14	★82-565-373-010	SCREW, THRUST		2
3-15	★87-087-029-010	CUSHION RBR		3
3-16	★87-067-441-010	SCREW, MOTOR STOPER		3
3-17	★81-507-221-010	MOTOR HOLDER		1
3-18	86-574-221-010	BELT A		1
3-19	86-574-214-010	FLYWHEEL T ASSY		1
3-20	★81-505-225-010	FLYWHEEL GEAR		1
3-21	86-574-222-010	BELT B		1
3-22	★81-505-234-110	PLAY CAM GEAR		1
3-23	★81-505-230-010	PLAY LEVER		1
3-24	★81-505-354-010	GEAR, FLYWHEEL 2.7		1
3-25	★81-505-261-010	C-SPRING, FLYWHEEL F		2
3-26	★81-505-235-210	PAUSE CAM GEAR		1
3-27	★81-505-308-010	PAUSE LEVER B		1
3-28	★81-505-272-010	T-SPRING, CAM		1
3-29	★81-505-283-010	T-SPRING, PAUSE LEVER		1
3-30	★86-574-223-010	LEVER SENSOR		1

# SPRING APPLICATION POSITION

