

**HiFi ENGINE®**

For more Hi-Fi manuals and set-up information  
please visit [www.hifiengine.com](http://www.hifiengine.com)



SERVICE  
MANUAL

1515/MR215/MR220

**marantz**

model 1515/MR215/MR220

*Stereophonic Receiver*



## MARANTZ DESIGN AND SERVICE

Using superior design and selected high grade components, MARANTZ Company has created the ultimate in stereo sound. Only original MARANTZ parts can insure that your MARANTZ product will continue to perform to the specifications for which it is famous.

Parts for your MARANTZ stereo are generally available within 72 hours throughout the nation via a toll-free line to our National Parts Depot in California. The sales professionals who take your call immediately refer to their own desk top computer terminal and can quickly determine the availability and price information you require. If, for some reason, your order should exceed our available stock, we usually can instantly provide an alternate replacement part or current delivery information. When the order is placed and confirmed, the computer simultaneously generates "hard copy" orders at the distribution center. As hard copies come directly from the computer to the national parts depot, your requested stock is assembled and prepared for shipment and placed on the first available carrier for delivery to you.

### ORDERING PARTS

Phone orders will eliminate mail delays, and we encourage the use of this method. If you order by mail, use MARANTZ parts order forms which are available from our National Parts Depot located at the following address:

SUPERSCOPE NATIONAL PARTS DEPARTMENT  
20525 Nordhoff Street  
Chatsworth, California 91311  
Phone: 1-800-423-5108  
1-213-998-9333

The following information must be supplied to eliminate delays in processing your order:

1. Complete address.
2. Complete part numbers.
3. Complete description of parts.
4. Model number for which part is required (indicate MARANTZ).
5. Account number (for account customers only).

Direct consumers will be provided with the current retail price quotation on available parts in order to advise them of the cost of the parts and shipping.

### OVERSEAS PARTS ORDERING

Parts may also be ordered from the following overseas addresses:

#### CANADA

Superscope Canada, Ltd.  
3710 Nashua Drive  
Mississauga  
Ontario, Canada L4V1M5

#### AUSTRALIA

Superscope (Australasia) Pty., Ltd.  
32 Cross Street (P.O. Box 604)  
Brookvale 2100 N.S.W.  
Australia

#### JAPAN

Marantz Japan, Inc.  
3622 Kamitsuruma  
Sagamihara Shi  
Kanagawa, Japan

#### EUROPE

Superscope Europe, S.A.  
Avenue Leopold III, 2  
7120 Peronnes-Lez-Binche  
Belgium

Marantz France  
Rue Louis Armand 9  
92600 Asnieres  
Hauts-de-Seine  
France

Marantz Audio U.K. Ltd.  
London Road, 203  
Staines  
Middlesex  
England

Superscope GmbH  
Max-Planck-Strasse 22  
D-6072 Dreieich 1  
West Germany

All of the above locations are fully equipped to take care of your total service needs. Because various countries have differing configuration requirements, it is necessary that you contact the service facility in your particular country. In the event that there is no service location listed for your country, please contact the nearest facility for the necessary assistance.

**marantz®**  
We sound better.

# TABLE OF CONTENTS

Section	Title	Page
1.	P.W. BOARDS	1
2.	TEST EQUIPMENT REQUIRED FOR SERVICING	2
3.	ALIGNMENT PROCEDURES	3
3.1	FM Alignment Procedures	3
3.2	Multiplex Alignment Procedures	4
3.3	AM Alignment Procedures	4
3.4	Audio Alignment Procedures	5
4.	VOLTAGE CONVERSION	5
5.	DIAGRAMS	6
5.1	Block Diagram	6
5.2	Tuner Board Schematic Diagram and Component Locations - P100	8
5.3	Phono Amp Board Schematic Diagram and Component Locations - P400	10
5.4	Main Amp & Power Supply Board Schematic Diagram and Component Locations - P700	11
5.5	Antenna Input Board Schematic Diagram and Component Locations - PC00	12
5.6	Tone Amp Board Schematic Diagram and Component Locations - PE00	12
5.7	Filter & Switch Board Schematic Diagram and Component Locations - PS00	13
5.8	LED Board Schematic Diagram and Component Locations - PY01	13
6.	EXPLODED VIEWS AND PARTS LIST	14
6.1	[C01-99] Front Panel	14
6.2	[C02-99] Lid (Top Cover)	15
6.3	[C03-99] Rear Panel	16
6.4	[P01-99] Front Chassis and General Parts	17
6.5	[P02-99] Assembled P.W. Boards and Other Parts	18
6.6	[H01-99] Packing Materials	20
6.7	Electrical Parts List	21
7.	TECHNICAL SPECIFICATIONS	27



# MODEL 1515/MR215/MR220 STEREPHONIC RECEIVER

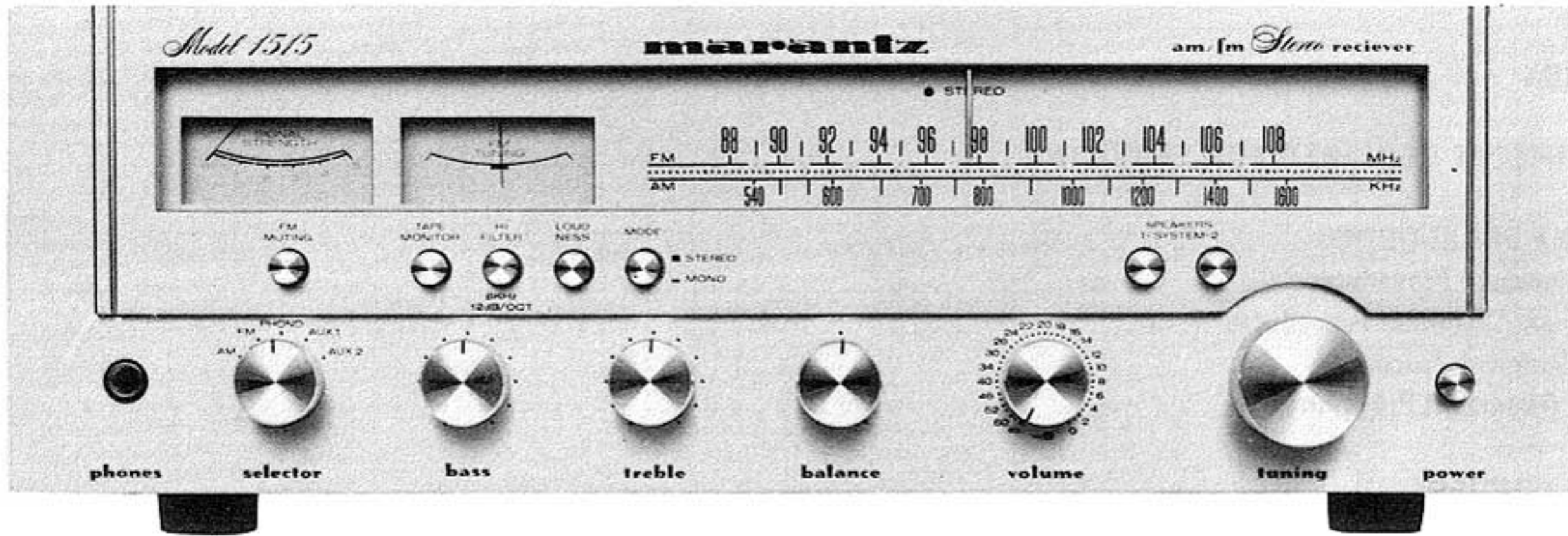

## INTRODUCTION

This service manual was prepared for use by Authorized Warranty Stations and contains service information for Marantz Model 1515/MR215/MR220 Stereophonic Receiver.

Servicing information and voltage data included in this manual are intended for use by the knowledgeable and experienced technician only. All instructions should be read carefully. No attempt should be made to proceed without a good understanding of the operation of the receiver.

The parts list furnishes information by which replacement parts may be ordered from the Marantz Company. A simple description is included for parts which can usually be obtained through local suppliers.

## 1. P.W. BOARDS

As can be seen from the circuit diagram, the chassis of Model 1515/MR215/MR220 consists of the following units. Each unit mounted on a printed circuit board is described within the square enclosed by a bold dotted line on the circuit diagram.

1. Tuner . . . . . mounted on P.W. Board P100
2. Phono Amp . . . . . mounted on P.W. Board P400
3. Main Amp . . . . . mounted on P.W. Board P700
4. Antenna Input . . . . . mounted on P.W. Board PC00
5. Tone Amp . . . . . mounted on P.W. Board PE00
6. Fuse . . . . . mounted on P.W. Board PP01
7. Switch . . . . . mounted on P.W. Board PS00
8. LED . . . . . mounted on P.W. Board PY01

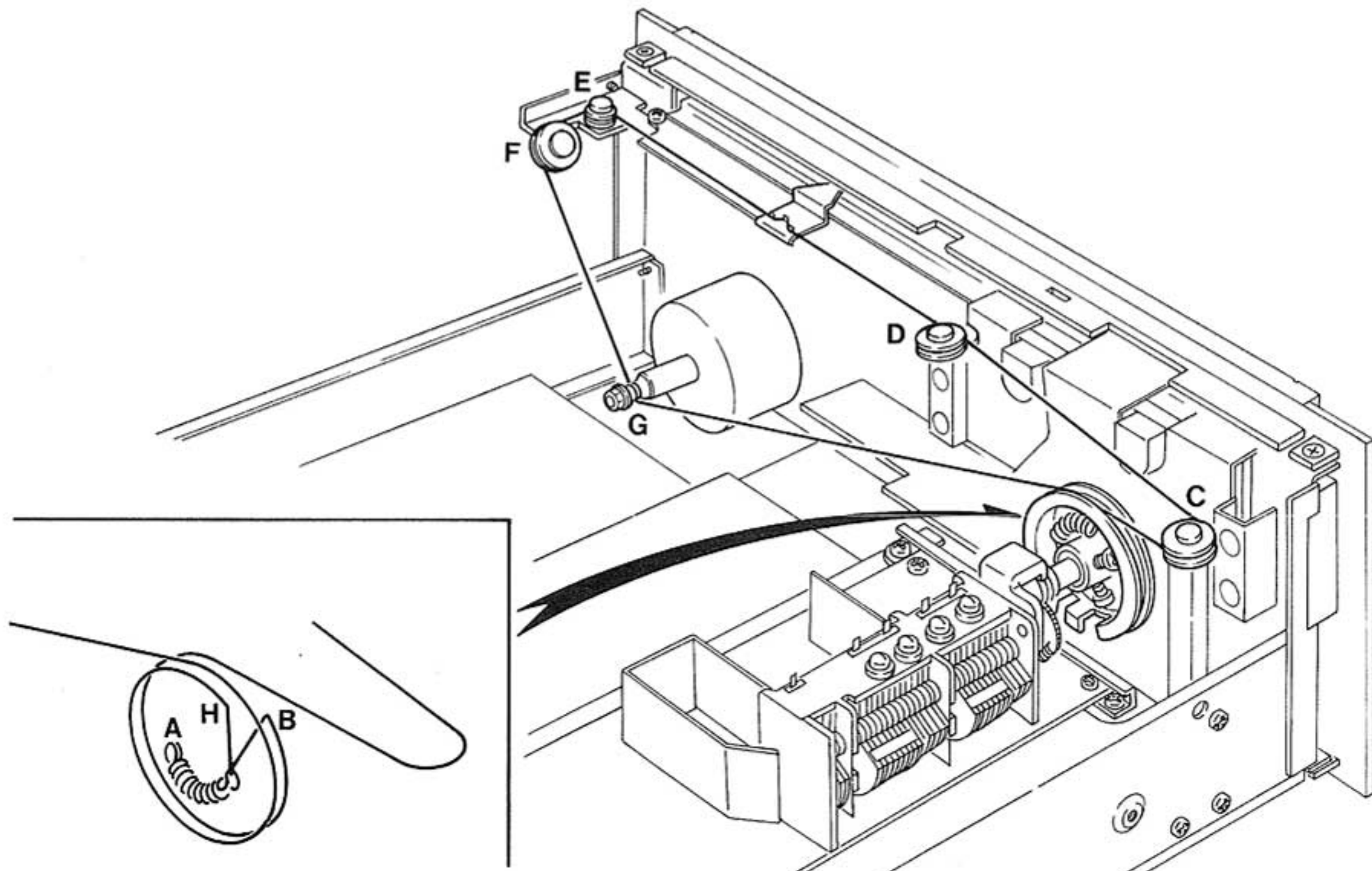

Figure 1. Dial Stringing

## 2. TEST EQUIPMENT REQUIRED FOR SERVICING

This table lists the test equipment required for servicing the Model 1515/MR215/MR220 Receiver.

Item	Manufacturer and Model No.	Use
AM Signal Generator		Signal source for AM alignment
Test Loop		Use with AM Signal Generator
FM Signal Generator MPX Signal Generator	Sound Technology Model 1000A	Signal source for FM alignment Stereo separation alignment and trouble shooting
Distortion Analyzer Audio Oscillator AC VTVM	Sound Technology Model 1700A	Distortion measurements Sinewave and squarewave signal source Voltage measurements (AC)
Oscilloscope	Tektronix Model T932 Philips Model 3232	Waveform analysis and trouble shooting and ASO alignment
Frequency Counter	Fluke Model 1900A	MPX Oscillator adjustment (VCO)
Circuit Tester		Trouble shooting
DC VTVM	Fluke Model 8000 "Digital" Simpson Model 313, Triplet Model 801	Voltage measurements (DC)
AC Wattmeter	Simpson Model 1379	Monitors primary power to amplifier
AC Ammeter	Commercial Grade (1-10A)	Monitors amplifier output under short circuit condition
Line Voltmeter	Simpson Model 1359	Monitors potential of primary power to amplifier
Variable Autotransformer	Superior Electronic Co., Powerstat Model 116B-10A	Adjusts level of primary power to amplifier
Shorting Plug	Use phono plug with 600-ohm across center pin and shell	Shorts amplifier input to eliminate noise pickup
Output Load (8 ohms, ± 0.5%, 100W)	Commercial Grade	Provides 8-ohm load for amplifier output termination
Output Load (4 ohms, ± 0.5%, 100W)	Commercial Grade	Provides 4-ohm load for amplifier output termination

### FTZ REGULATION

Instruction for the use in the range other than specified in FTZ codes.

**Achtung für die Leute, die in dem Gebiet wohnen, wo die FTZ-Bestimmungen vorherrschend sind.**

Sollte das Gerät auch für Frequenzen ausserhalb des in den FTZ-Bestimmungen angegebenen Bereiches empfangebereit sein, bitten wir, den Bereich durch Nachstellen des Kernes in der Oszillatordspule (in der Abbildung mit "FTZ" gekennzeichnet) so zu korrigieren, dass er den Bestimmungen entspricht.



### 3. ALIGNMENT PROCEDURES

\* A dummy resistor of 47 kohms must be connected across the tape output terminals before alignment.

#### 3.1 FM ALIGNMENT PROCEDURES

(Selector switch in the "FM" position)

Step	Signal Source Connection	Signal Frequency	Indicator Connection	Set Dial Pointer to:	Adjust:
<b>FM IF ALIGNMENT</b>					
1	Sweep generator to point (B) through 5pF capacitor	10.7 MHz market at 10.6, 10.7 and 10.8 MHz	Oscilloscope to point (C)	Quiet point on band.	L104 for maximum and symmetric response.
2			Oscilloscope to point (D)		L201 for straight and symmetric "S" curve response.
3	Repeat steps 1 and 2.				
<b>FM RF ALIGNMENT</b>					
1	RF generator to FM antenna terminals (A) through matching network (300 ohms, balanced) Maintain RF level below limit.)	87.4 MHz	VTVM to L or R channel output (W002)	87.4 MHz with tuning gang closed.	L103 for maximum output.
2		100 MHz		109 MHz with tuning gang open.	C119 for maximum output.
3		90 MHz		90 MHz	L101, L102 for maximum output.
4		106 MHz		106 MHz	Ant. RF trimmer for maximum output.
5	Repeat steps 1 to 4.				
6	Check overall response curve and repeat above steps as necessary to obtain maximum sensitivity.				
7	No connection	No signal	DC VTVM 1-volt range to (D)	—	L201 primary core (bottom) for "0" voltage reading.
8	RF generator 1 mV output to FM antenna terminals (A) through matching network (300 ohms, balanced)	98 MHz	Distortion meter to (D)	98 MHz	L201 secondary core (upper) for minimum distortion.
9			—		R232 so that signal strength meter M001 may read 85%.
<b>MUTING CIRCUIT ALIGNMENT</b>					
1	RF generator 12.5μV output to FM antenna terminals (A) through matching network (300 ohms, balanced)	98 MHz	VTVM to R or L channel output (W002)	98 MHz	R233 for 12.5μV threshold level. (During the adjustment turn the muting pushswitch "ON").

### 3.2 MULTIPLEX ALIGNMENT PROCEDURES

(Selector switch in the "FM" position)

Step	Signal Source Connection	Signal Frequency	Indicator Connection	Set Dial Pointer to:	Adjust:
1	RF generator to FM antenna terminals (A) through matching network (300 ohms, balanced), with 1mV FM stereo simulator RF level and 100% modulation (pilot 9%)	No modulation	Frequency counter to point (E) (J140)	98 MHz	R326 so that frequency counter may precisely read 19 kHz.
2		Stereo, left (1,000 Hz)	VTVM to right channel output (W002, White)		R316 for maximum output and same separation in both channels.
3		Stereo, right (1,000 Hz)	VTVM to left channel output terminal (H) (J123) (W002, Red)		
4	Repeat steps 2 and 3.				

### 3.3 AM ALIGNMENT PROCEDURES

(Selector switch in the "AM" position)

Step	Signal Source Connection	Signal Frequency	Indicator Connection	Set Dial Pointer to:	Adjust:
<b>AM IF ALIGNMENT</b>					
1	No connection	No signal	—	—	R228 to that signal strength meter M001 may read 0.
2	Sweep generator to point (F)	455 kHz marker	Oscilloscope to point (G) (J141)	Quiet point on band.	L154 for maximum and symmetric response.
<b>AM RF ALIGNMENT</b>					
1	RF generator to AM antenna terminals through IHF dummy	515 kHz	VTVM to L or R channel output (W002)	515 kHz with tuning gang closed.	L153 for maximum output.
2		1,650 kHz		1,650 kHz with tuning gang open.	OSC. trimmer for maximum output.
3		600 kHz		600 kHz	L001 for maximum output.
4		1,400 kHz		1,400 kHz	Ant. trimmer for maximum output.
5	Repeat steps 1 to 4 as necessary to obtain maximum sensitivity.				



### 3.4 AUDIO ALIGNMENT PROCEDURES

(Selector switch in the "AUX" position)

	Signal Source Connection	Signal	Indicator Connection	Adjustment
Distortion meter used	AF oscillator to AUX jack	20 kHz	Distortion meter to SPK OUT terminals with 4Ω load.	Wait 2 min. after power has been on. Adjust R717 and R718 until distortion for 0.25W output is minimum. <b>CAUTION:</b> After adjustment, disconnect input signal, and make certain that current flowing from R741 to R744 is 10 to 30 mA.
Voltmeter used	—	—	DC voltmeter in 100 mV or 50 mV range to R741 (R743) and R742 (R744).	Adjust R717 and R718 until current is 10 mA.

### 4. VOLTAGE CONVERSION (FOR EUROPEAN MODEL ONLY)

The Model 1515/MR215 is equipped with a universal power transformer that may be adjusted to operate at 110 V, 120 V, 220 V, or 240 V AC at 50 to 60 Hz. To convert the unit to a different power source voltage, reposition conversion plug as shown in Figure 2.

**CAUTION: DISCONNECT POWER SUPPLY CORD FROM AC OUTLET BEFORE CONVERTING VOLTAGE.**

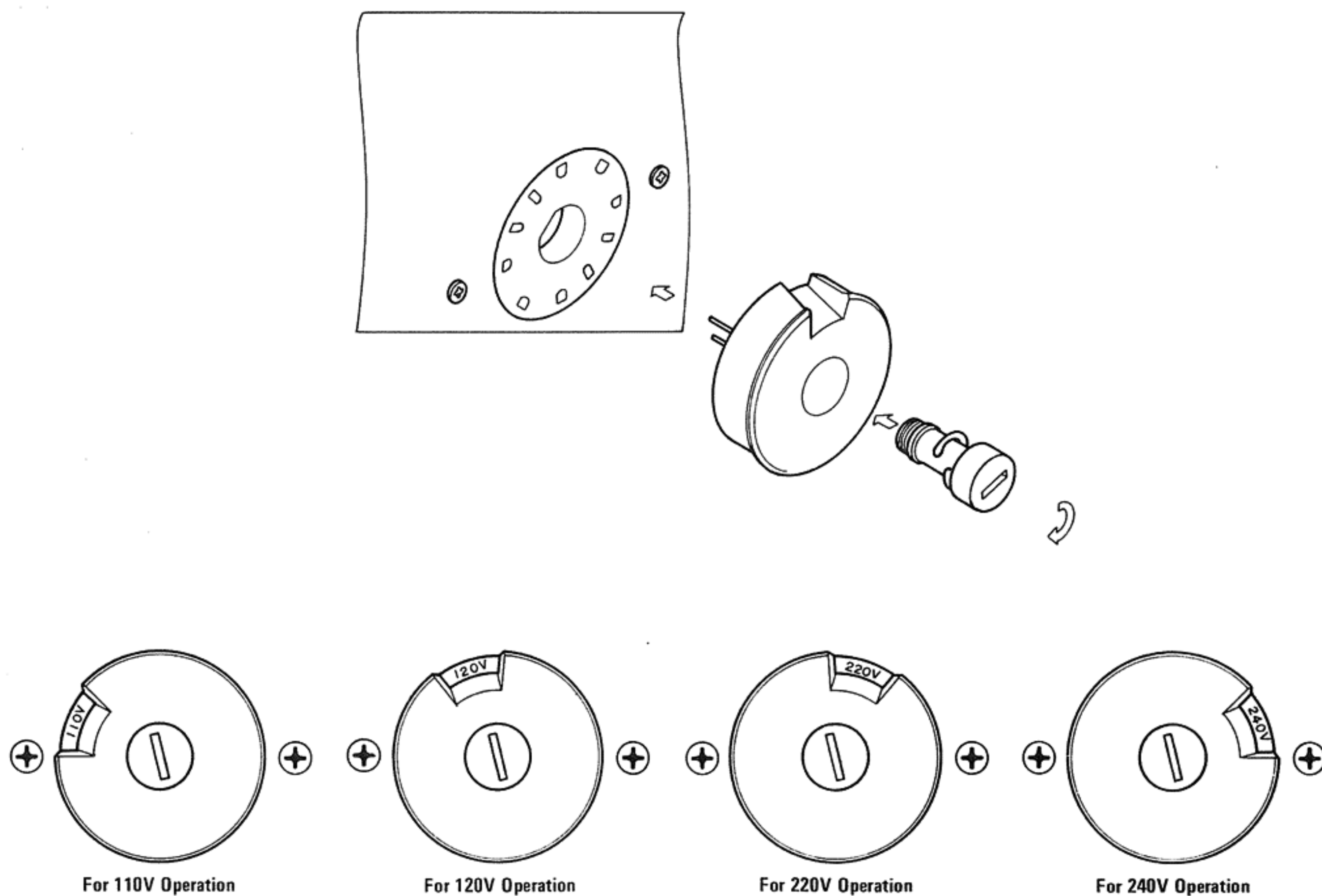
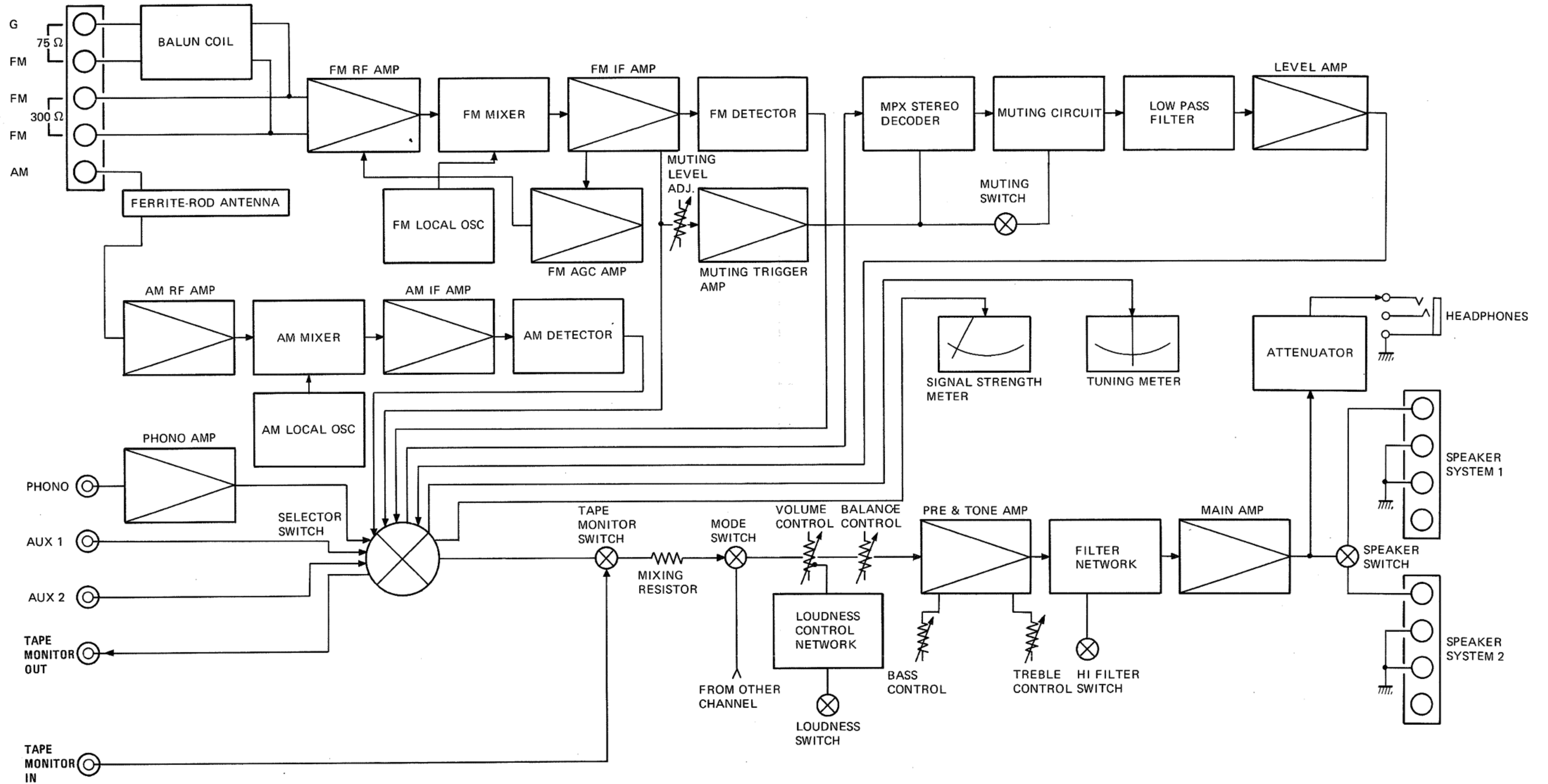

Figure 2. Voltage Conversion Chart

# 5. DIAGRAMS

## 5.1 BLOCK DIAGRAM





# 5.2 TUNER BOARD SCHEMATIC DIAGRAM AND COMPONENT LOCATIONS - P100

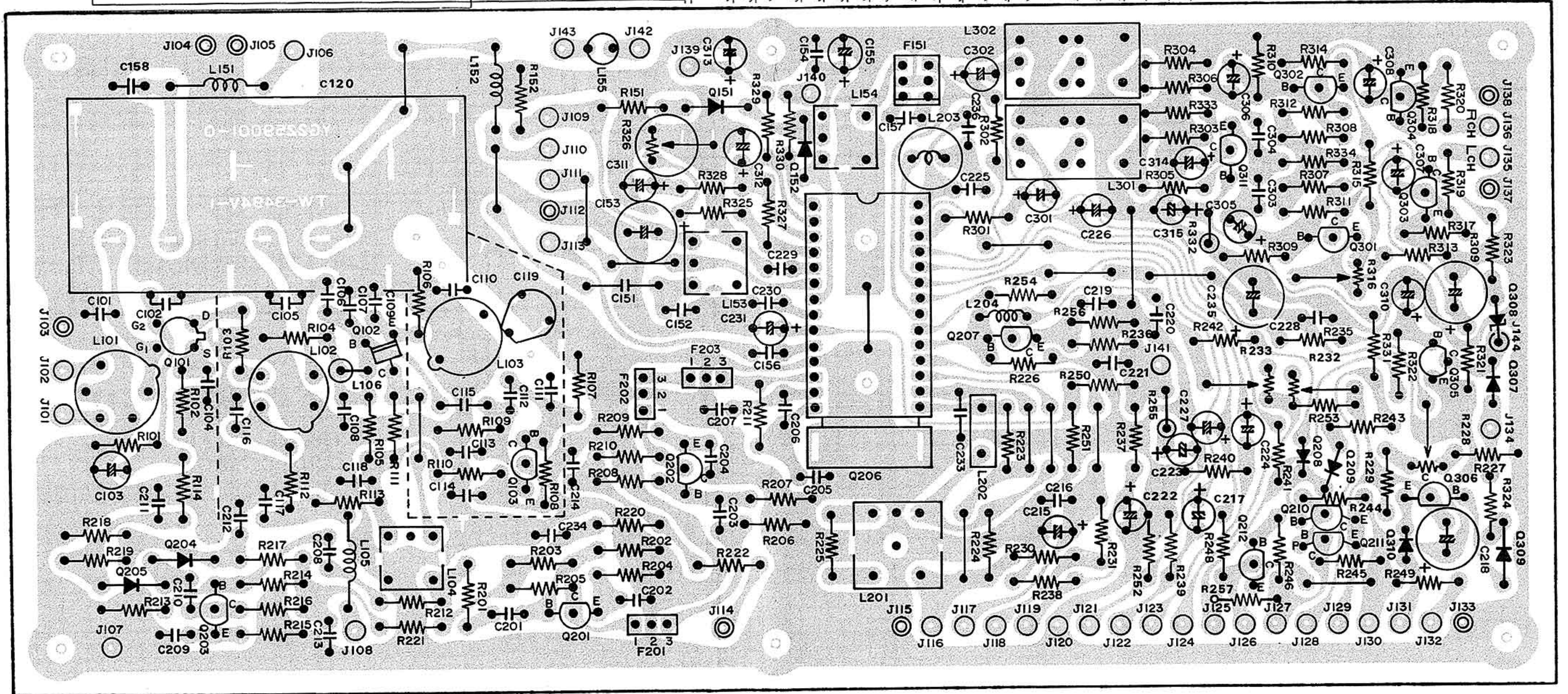
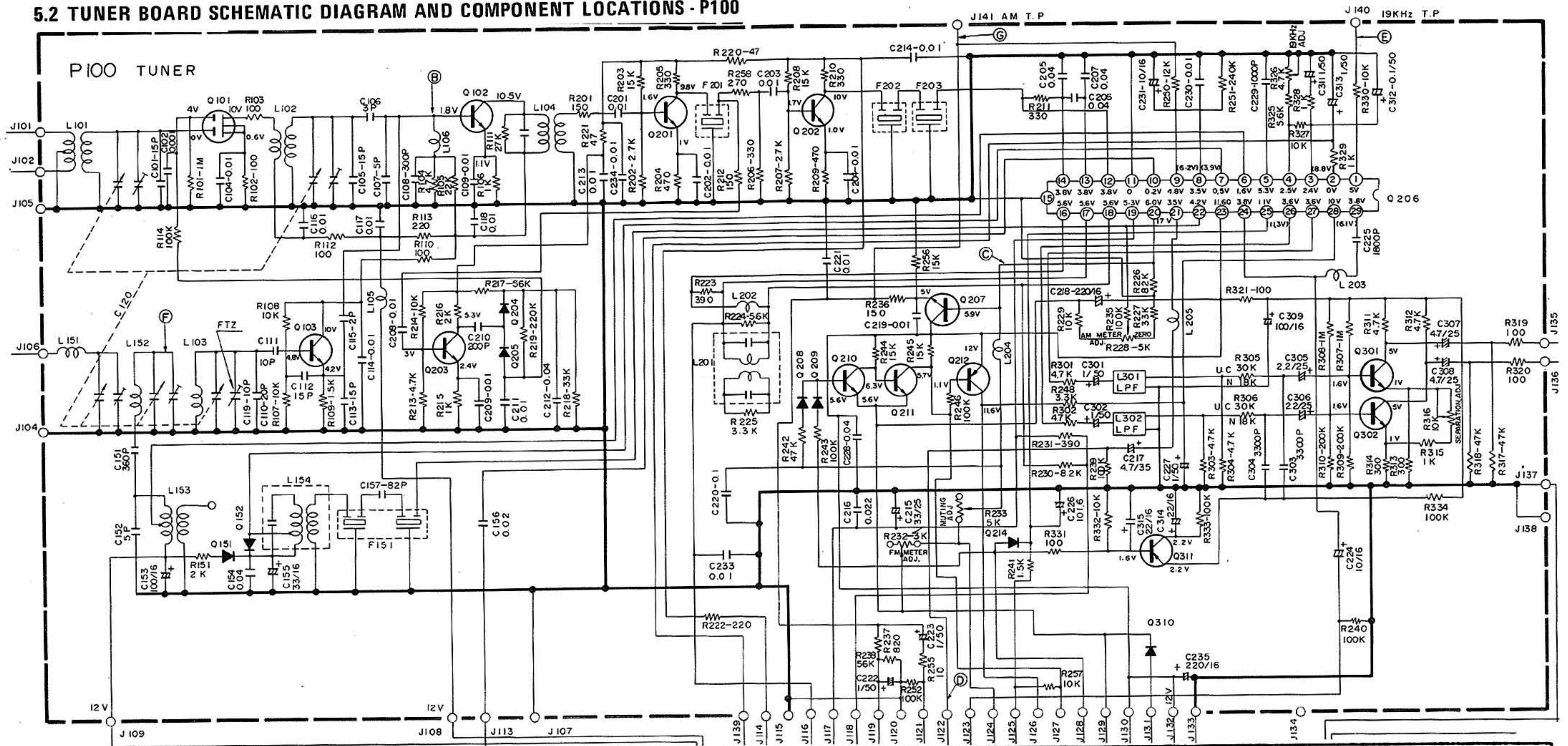



5.3 PHONO AMP BOARD SCHEMATIC DIAGRAM AND COMPONENT LOCATIONS - P400

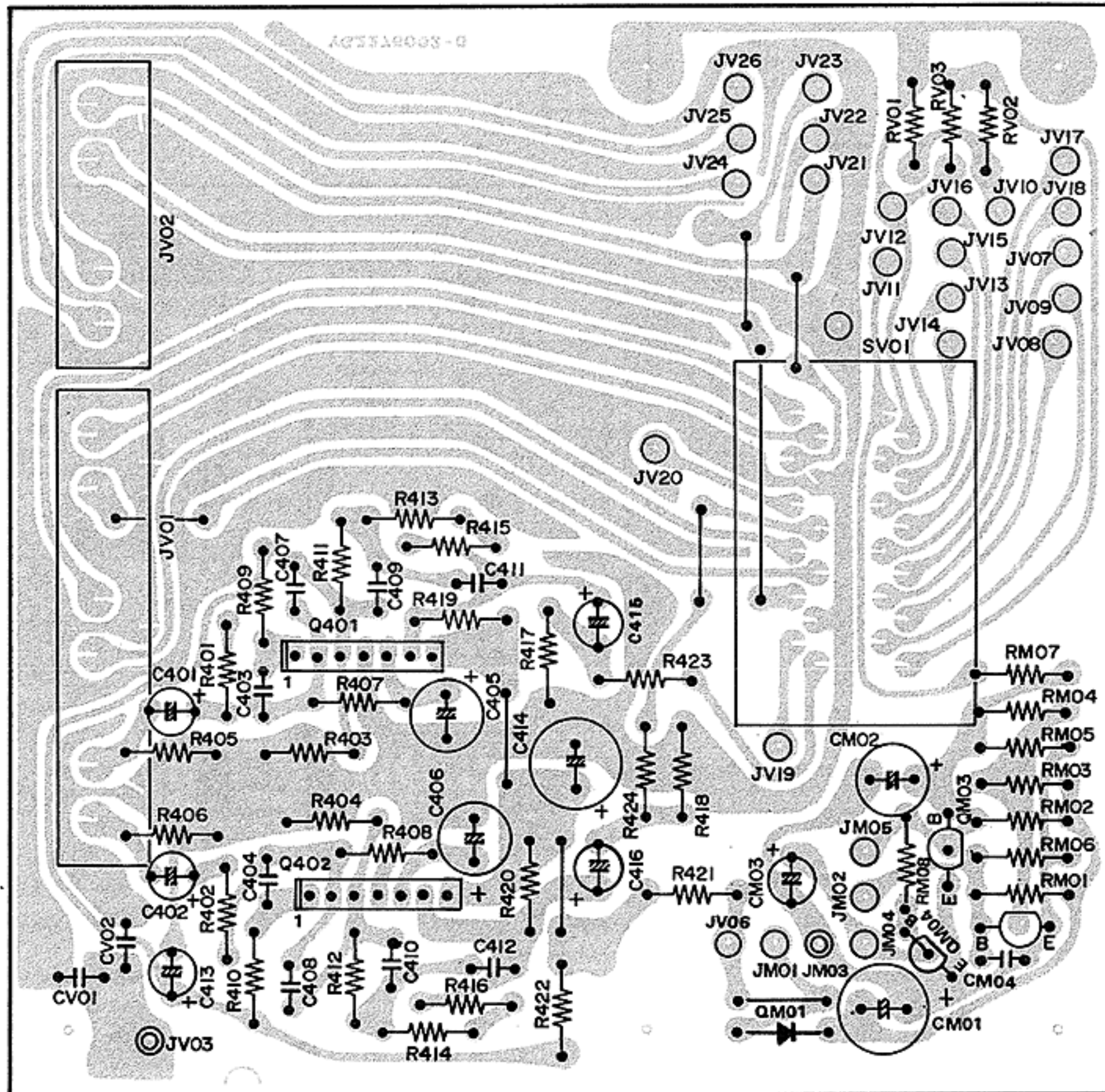
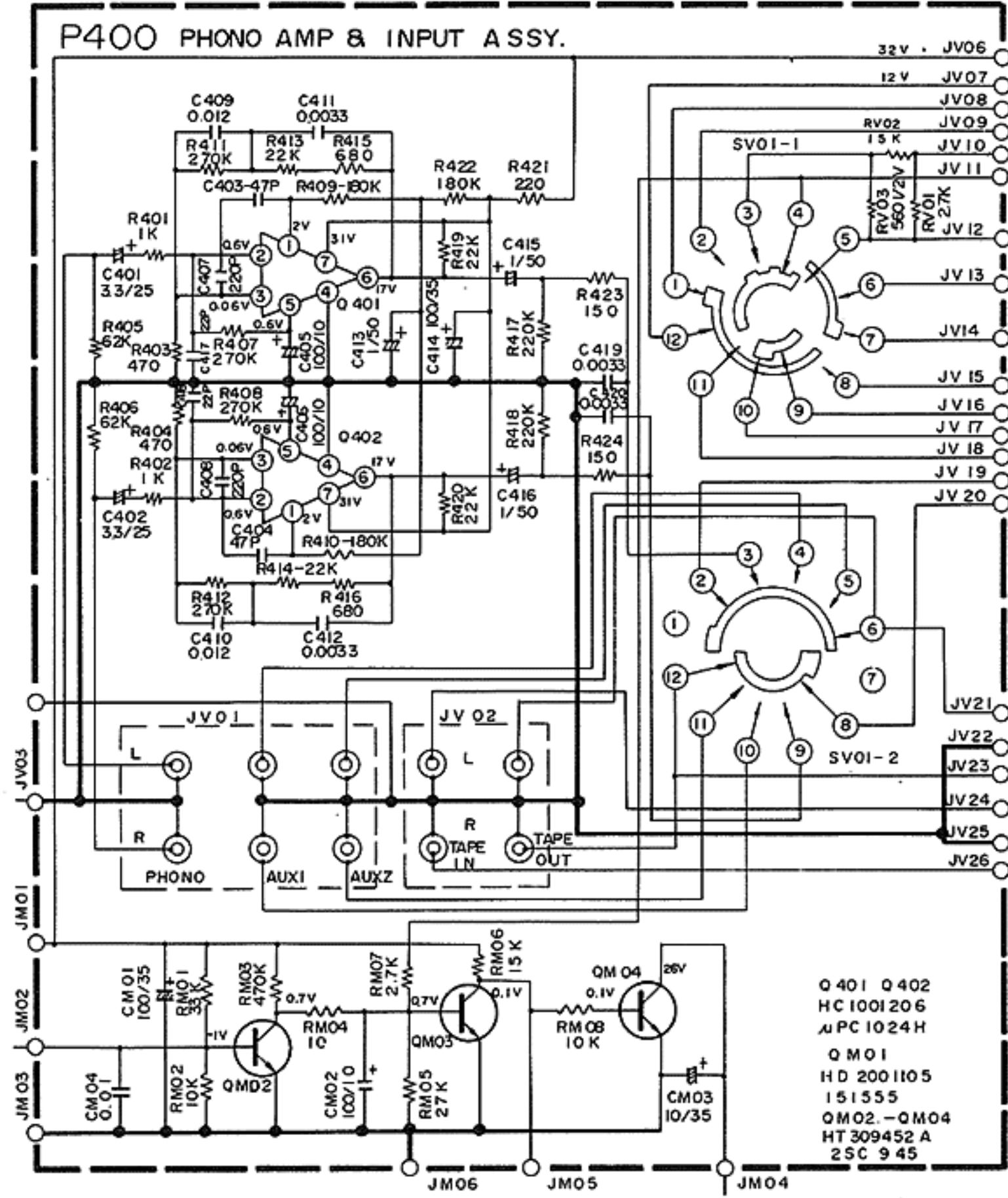

YG2276002-0



# 5.4 MAIN AMP & POWER SUPPLY BOARD SCHEMATIC DIAGRAM AND COMPONENT LOCATIONS - P700

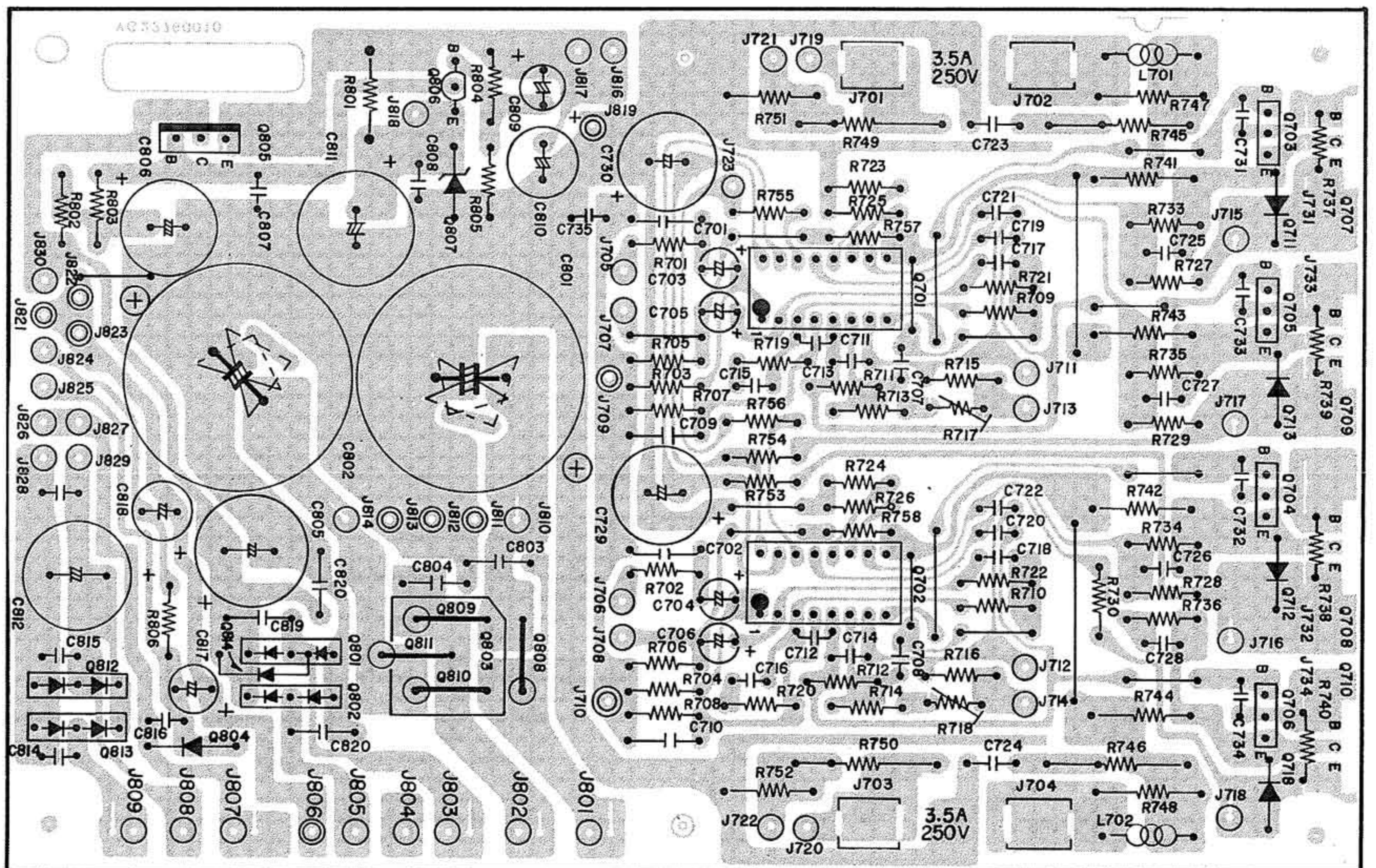
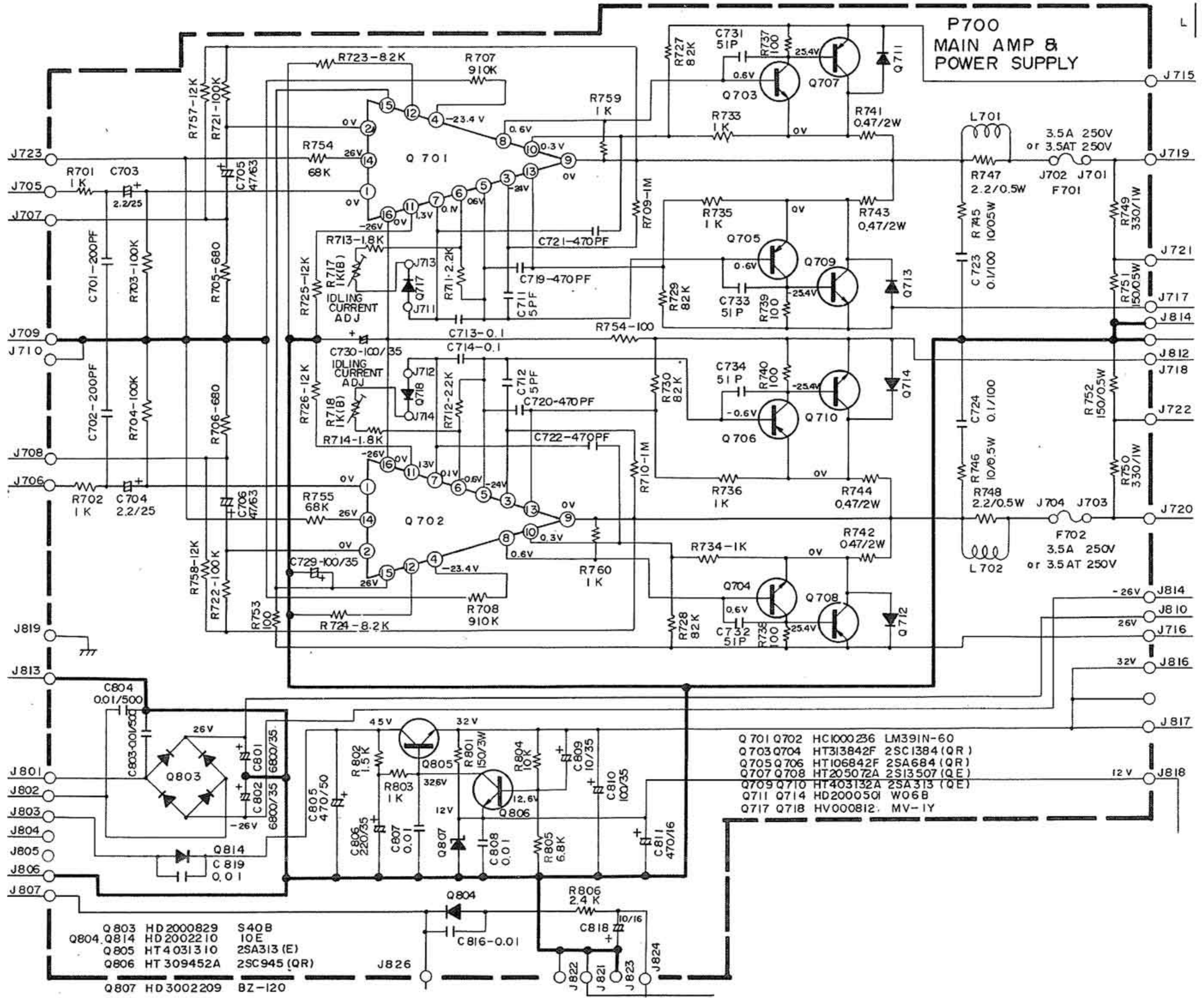



### 5.5 ANTENNA INPUT BOARD SCHEMATIC DIAGRAM AND COMPONENT LOCATIONS - PC00

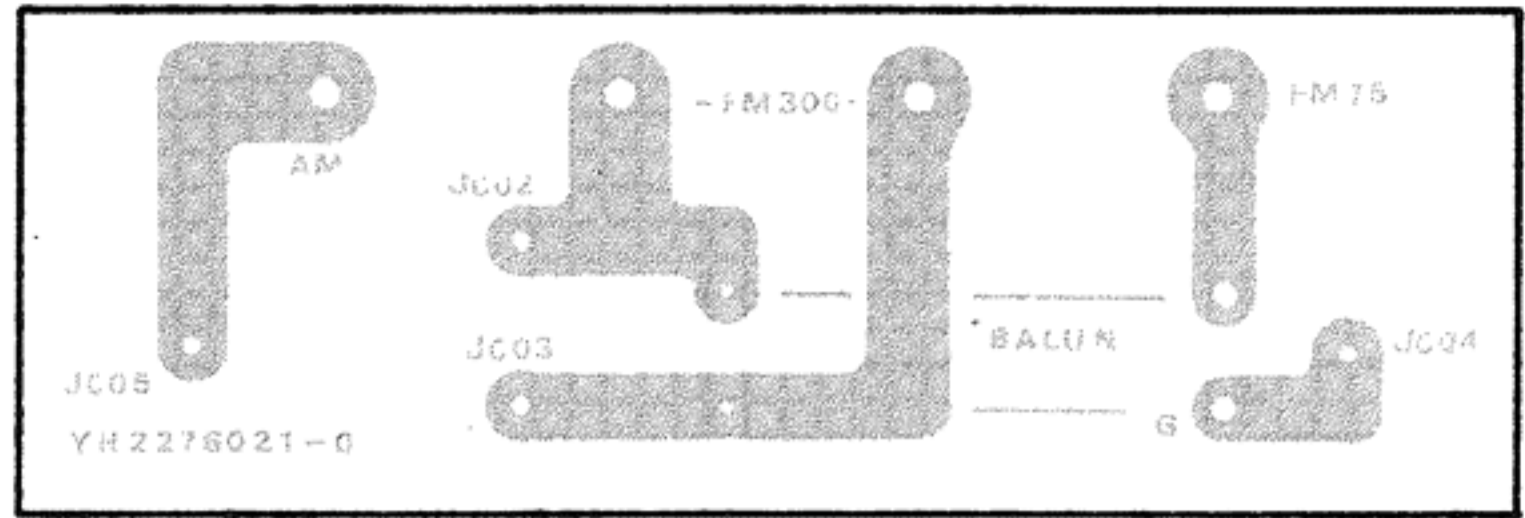
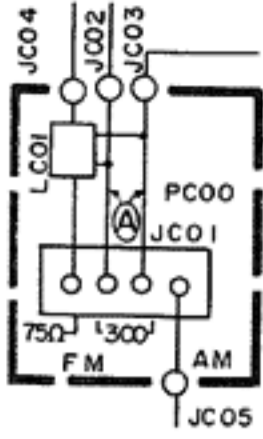

### 5.6 TONE AMP BOARD SCHEMATIC DIAGRAM AND COMPONENT LOCATIONS - PE00

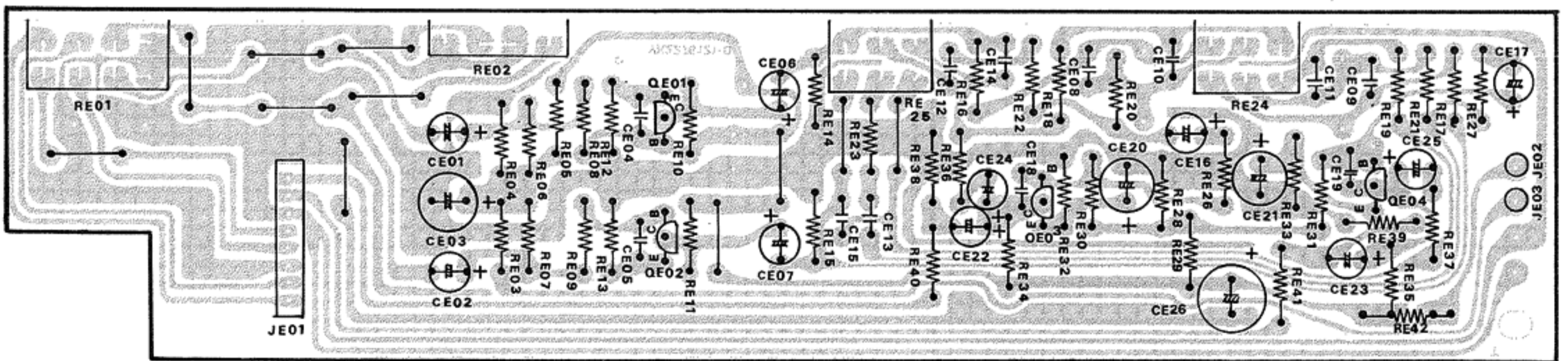
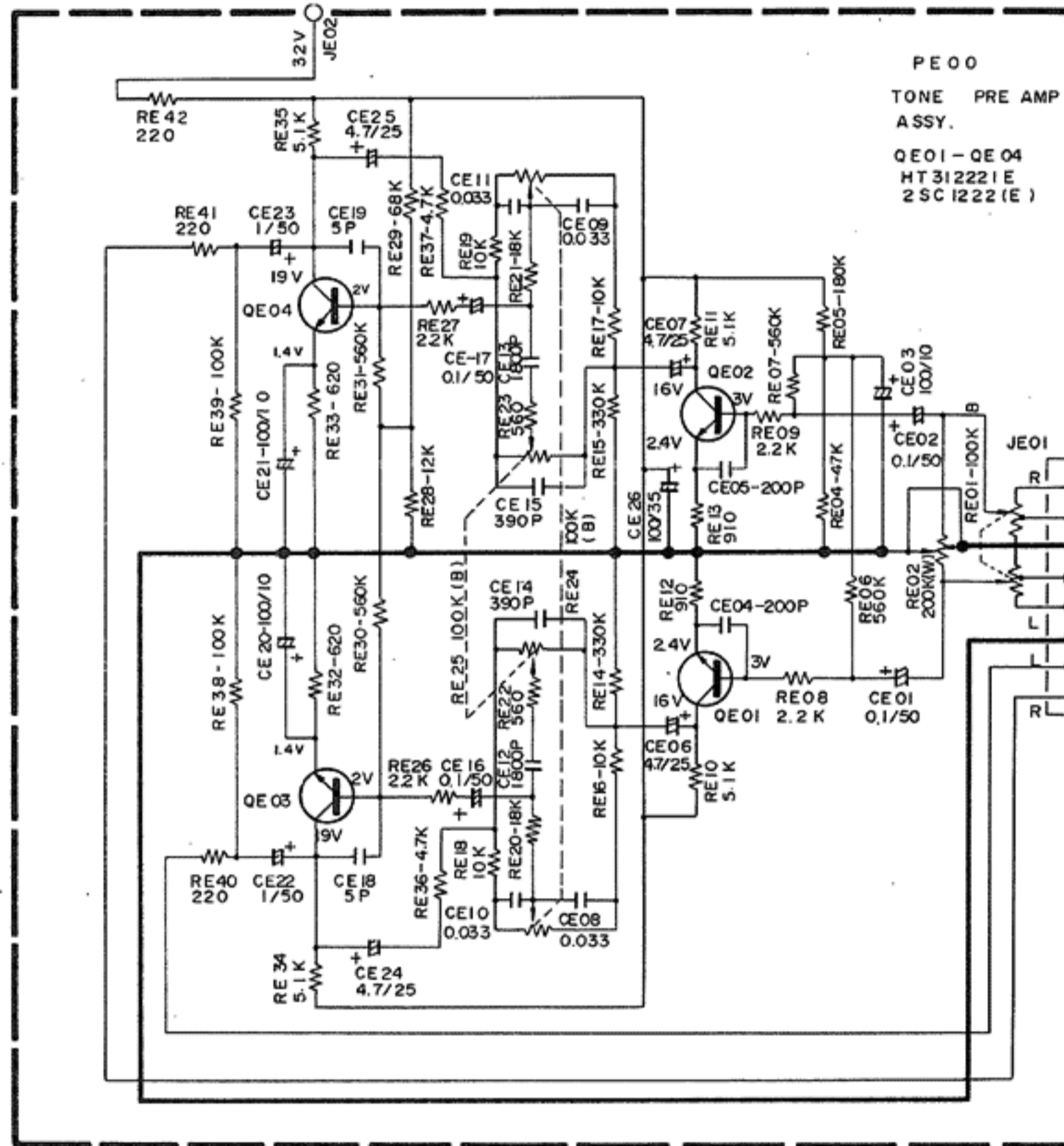



### 5.7 FILTER & SWITCH BOARD SCHEMATIC DIAGRAM AND COMPONENT LOCATIONS - PS00

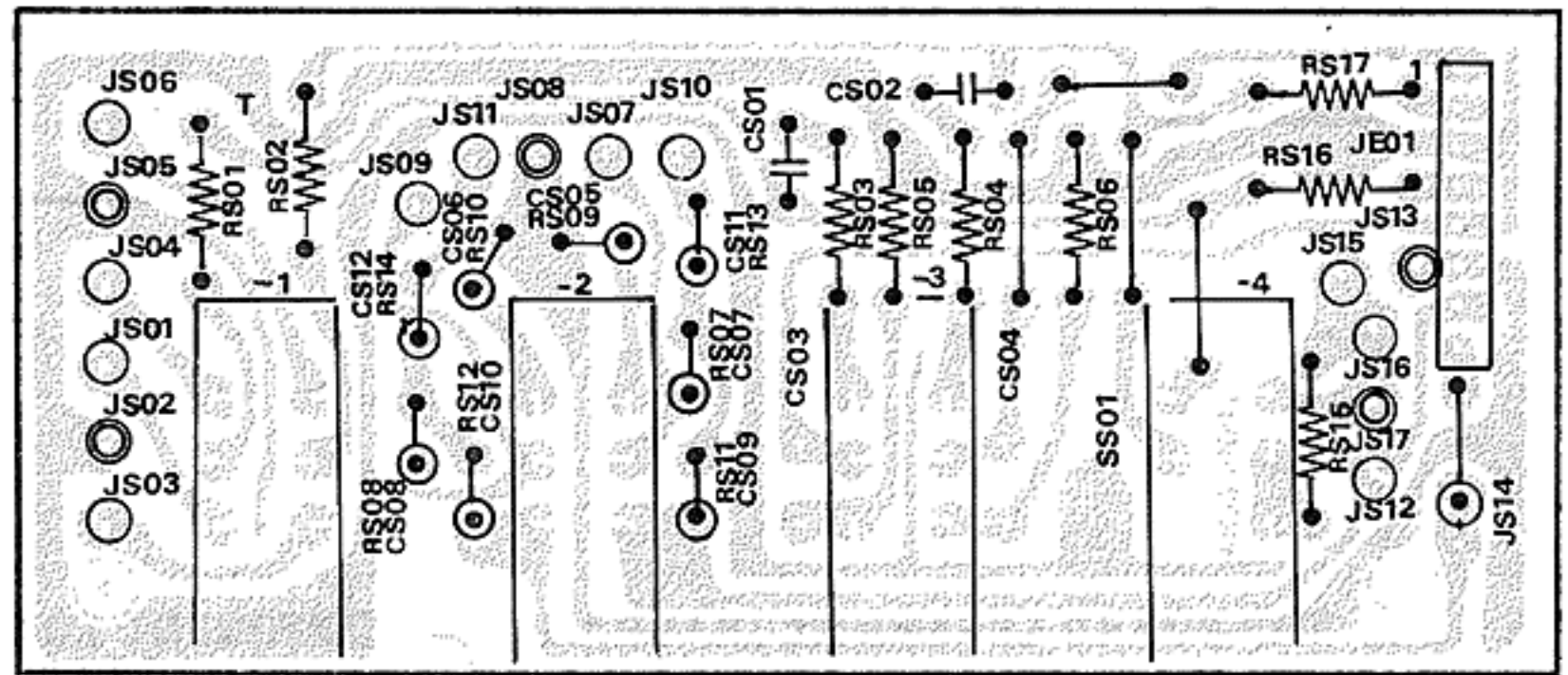
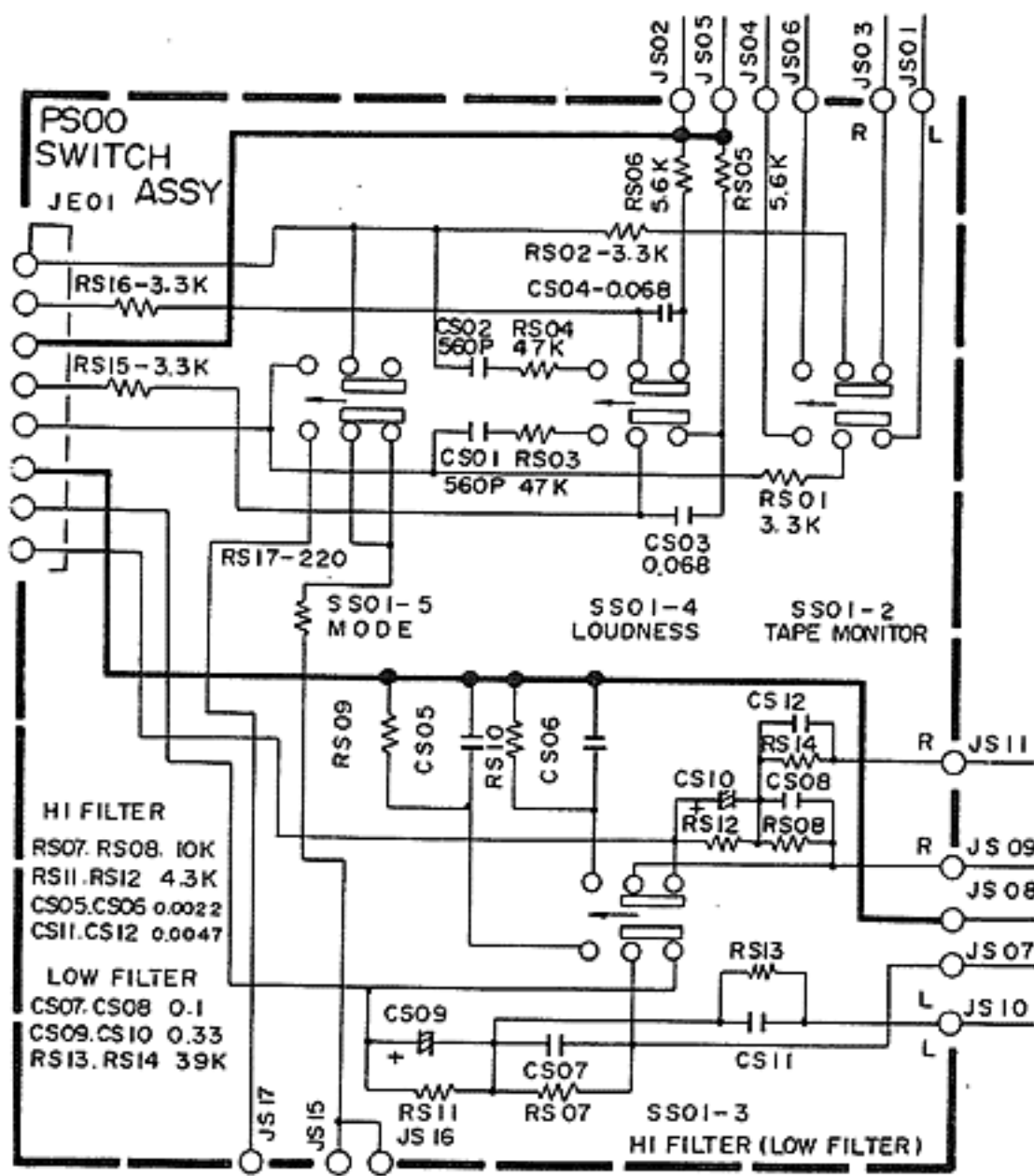

### 5.8 LED BOARD SCHEMATIC DIAGRAM AND COMPONENT LOCATIONS - PY01

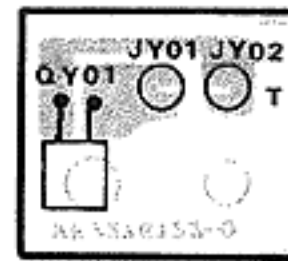
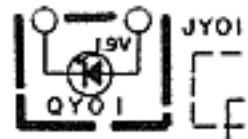

# 6. EXPLODED VIEWS AND PARTS LIST

## 6.1 [C01-99] FRONT PANEL

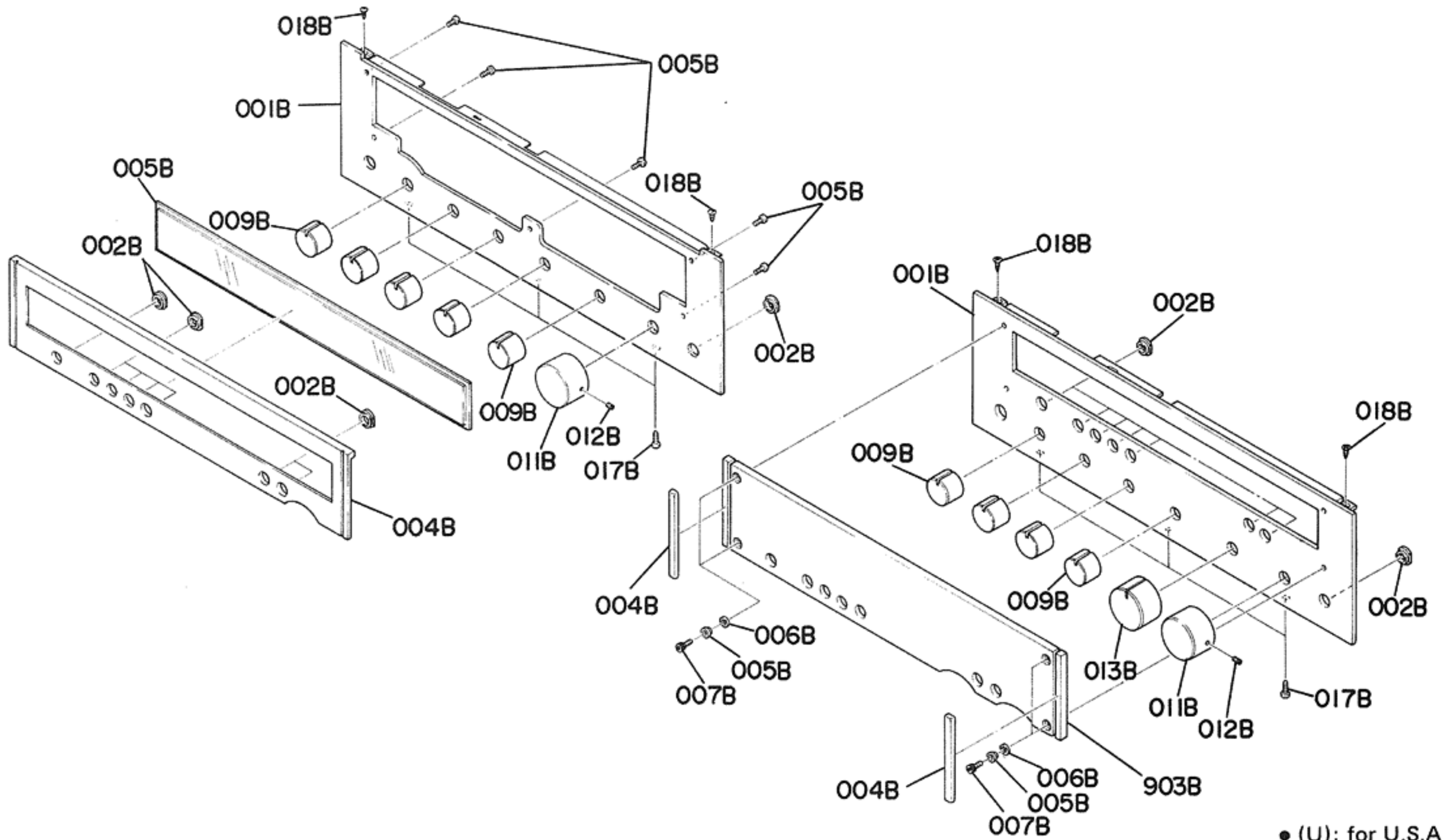

● (U): for U.S.A.  
 ● (C): for Canada  
 ● (N): for Europe

REF. DESIG.	Q'TY			PART NO.	DESCRIPTION
	U	C	N		
<b>M1515, ONLY</b>					
A	1	1		2276063400	Front Panel Assembly
A1			1	2276063410	Front Panel Assembly
001B	1	1	1	2276063112	Escutcheon, Main
002B	8	8	8	2978259012	Bushing
004B	1	1		2276063122	Escutcheon, Sub
004B			1	2276063220	Escutcheon, Sub
005B	1	1	1	2211158110	Window
007B	5	5	5	51100305A9	B.H.M. Screw B3 x 5
<b>MR215, ONLY</b>					
A			1	2468063400	Front Panel Assembly
001B			1	2276063010	Escutcheon, Main
002B			8	2978259012	Bushing
004B			2	2276067010	Cap
005B			4	2470055010	Collar
006B			4	4214107010	Sheet
007B			4	52730308S9	H.S. Head Bolt H3 x 8
903B			1	2468158014	Window
<b>MR220, ONLY</b>					
A	1			2276063420	Front Panel Assembly
001B	1			2276063112	Escutcheon
002B	8			2978259012	Bushing
004B	1			2276063132	Escutcheon
005B	1			2211158110	Window
007B	5			51100305A9	B.H.M. Screw B3 x 5

REF. DESIG.	Q'TY			PART NO.	DESCRIPTION
	U	C	N		
009B	5	5	5	2276154010	Knob (M1515, ONLY)
009B			4	2276154010	Knob (MR215, ONLY)
011B	1	1	1	2279154040	Knob, Tuning
012B	1	1	1	51690306Q9	Socket Screw, HP 3 x 6
013B			1	2276154030	Knob, Volume (MR215, ONLY)
017B	3	3	3	51280308U0	B.H. Tapped Screw B3 x 8
018B	2	2	2	51340306B0	F.H. Tapped Screw F3 x 6
<b>M1515 (U)(C)(N)</b> <b>MR215 (N), ONLY</b> <b>MR220 (U), ONLY</b>					



6.2 [C02-99] LID (TOP COVER)

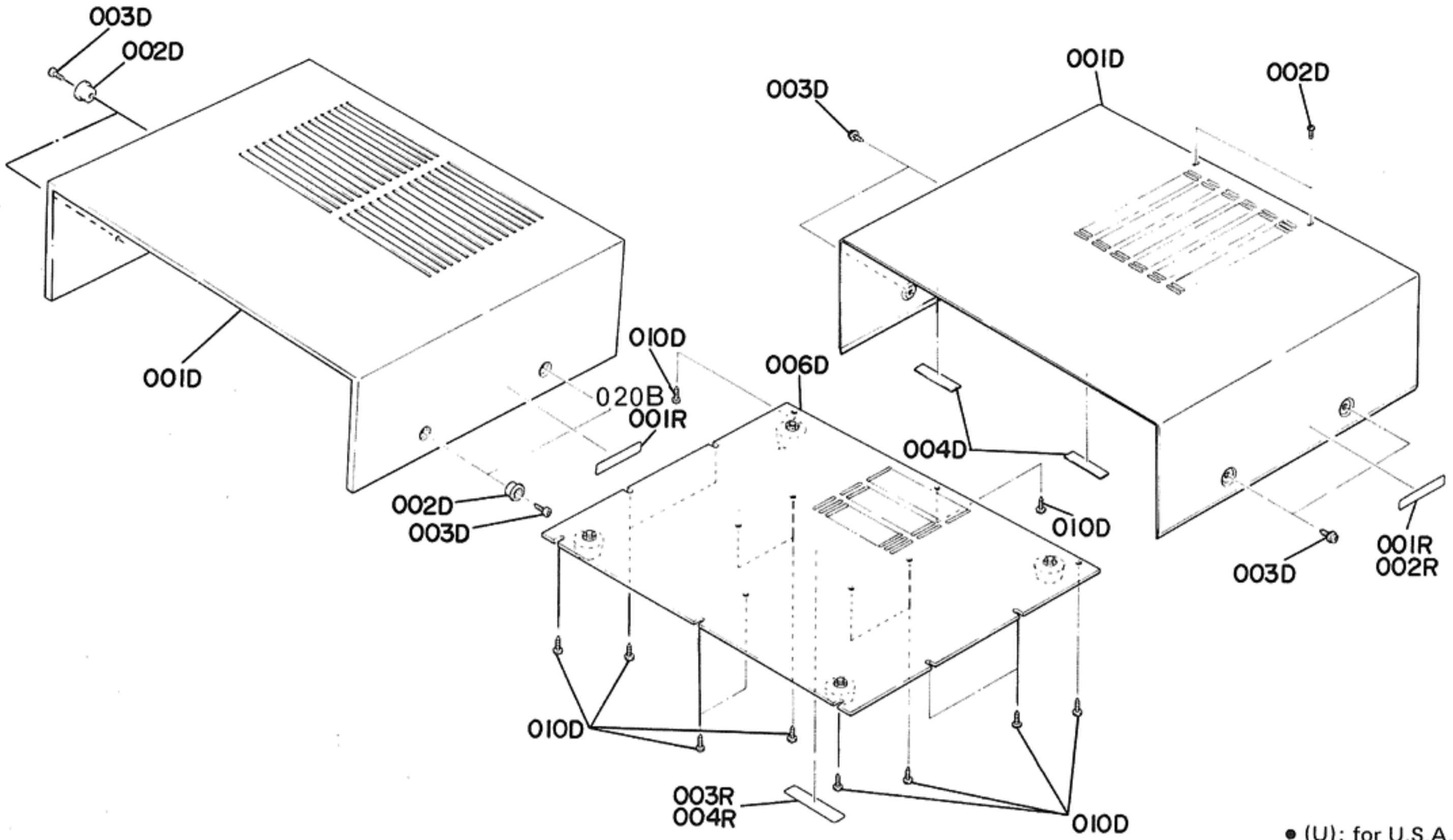

• (U): for U.S.A.  
 • (C): for Canada  
 • (N): for Europe

REF. DESIG.	Q'TY			PART NO.	DESCRIPTION
	U	C	N		
<b>M1515, ONLY</b>					
001D	1	1	1	2276257020	Lid, Metal Case
002D	2	2	2	51280306U0	B.H. Tapped Screw B3 x 6
003D	4	4	4	51260408U0	F. Washer Screw F4 x 8
004D	2	2	2	2965118010	Spacer
<b>MR215, MR220</b>					
001D	1		1	2276064010	Case, Wood
002D	4		4	3906259010	Bushing
003D	4		4	51280412U0	B.H. Tapped Screw B4 x 12
020B	1			2818861010	Label

REF. DESIG.	Q'TY			PART NO.	DESCRIPTION
	U	C	N		
006D	1	1	1	2276257500	Lid, Bottom
010D	15	15	15	51280410U0	B.H. Tapped Screw B4 x 10
001R	1		1	2932861012	Label
002R		1		2911861143	Label
003R	1		1	2578861010	Label
004R		1		2911861112	Label
<b>M1515 (U)(C)(N) MR215 (N), ONLY MR220 (U), ONLY</b>					

### 6.3 [C03-99] REAR PANEL

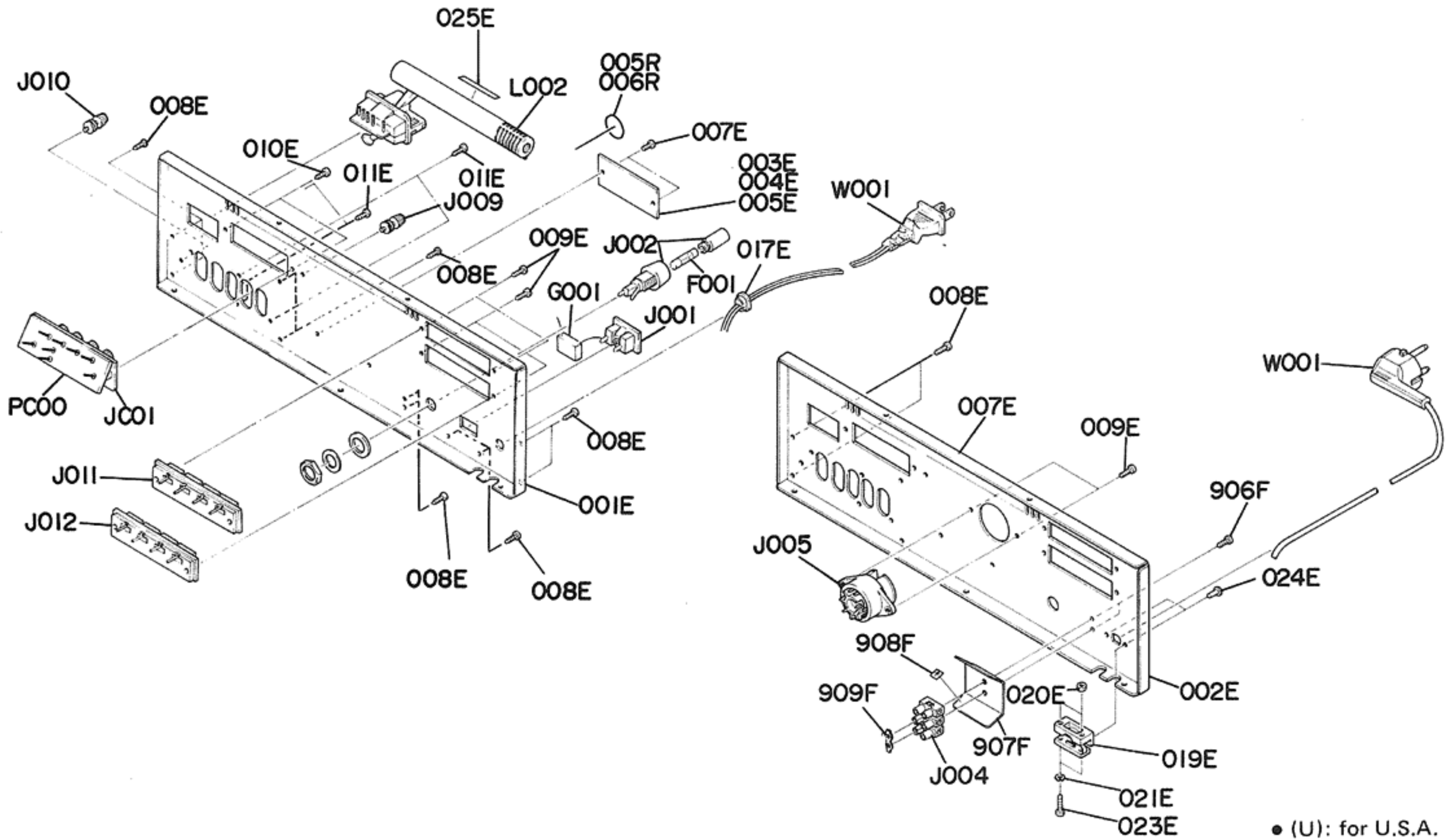

● (U): for U.S.A.  
 ● (C): for Canada  
 ● (N): for Europe

REF. DESIG.	Q'TY			PART NO.	DESCRIPTION
	U	C	N		
001E	1	1		2276160213	Bracket, Rear Panel
002E			1	2276160223	Bracket, Rear Panel
003E	1			2276265010	Indicator
003E	1			2276265040	Indicator (MR220, ONLY)
004E		1		2276265020	Indicator
005E			1	2276265030	Indicator (M1515, ONLY)
005E			1	2468265010	Indicator (MR215, ONLY)
007E	2	2	2	51760306B0	OS. Tapped Screw 3 x 6
008E	10	10	10	51280308U0	B.H. Tapped Screw B3 x 8
009E	4	4	4	51280308U0	B.H. Tapped Screw B3 x 8
010E	2	2	2	51280308U0	B.H. Tapped Screw B3 x 8
011E	6	6	6	51280308U0	B.H. Tapped Screw B3 x 8
012E			2	51100308S9	B.H.M. Screw B3 x 8
017E	1	1		1455259030	Bushing
019E			1	2821259010	Bushing
020E			2	53110303A9	Hexagon Nut
021E			2	54050300R0	T.L. Washer OR
023E			2	51060316A9	P.H.M. Screw P3 x 16
024E			2	55060305S0	T.R. Rivet
025E	1		1	2506265062	Indicator
025E		1		2911861172	Indicator
906F			2	51100316S9	B.H.M. Screw B3 x 16
907F			1	3953120030	Insulator
908F			1	2882861020	Label
909F			1	2970005010	Clamper

REF. DESIG.	Q'TY			PART NO.	DESCRIPTION
	U	C	N		
005R	1			9511101020	Label
006R		1		2457861040	Label
F001	1	1		FS10250040	Fuse 2.5A 250V
F001			1	FS10160800	Fuse 1.6AT 250V
G001	1			BF10400030	Cap. Comp 0.1μF + 120Ω
G001		1		BF10400050	Cap. Comp 0.1μF + 120Ω
J001	1	1		YJ04000560	Jack, AC Outlet
J004			1	YL09030010	Terminal (3P)
J002	1			YJ08000120	Jack, Fuse Holder
J002		1		YJ08000230	Jack, Fuse Holder
J002			1	YJ08000220	Jack, Fuse Holder
J005			1	BY03110010	Plug, Voltage Selector
J010	1	1	1	YL03010240	Terminal, Ground
J011	1	1	1	YT03040160	Terminal, Speaker
J012	1	1	1	YT03040160	Terminal, Speaker
J009	1	1	1	YL03010240	Terminal, Ant, Ground
L002	1	1	1	LF11200620	Antenna Coil
W001	1	1		YC02000150	A.C. Power Cord
W001			1	YC01900030	A.C. Power Cord
PC00	1	1	1	YH22760210	P.W. Board, Antenna
	1	1	1	ZZ22760210	P.W. Board Assembly
JC01	1	1	1	YT01040182	Terminal



6.4 [P01-99] FRONT CHASSIS AND GENERAL PARTS

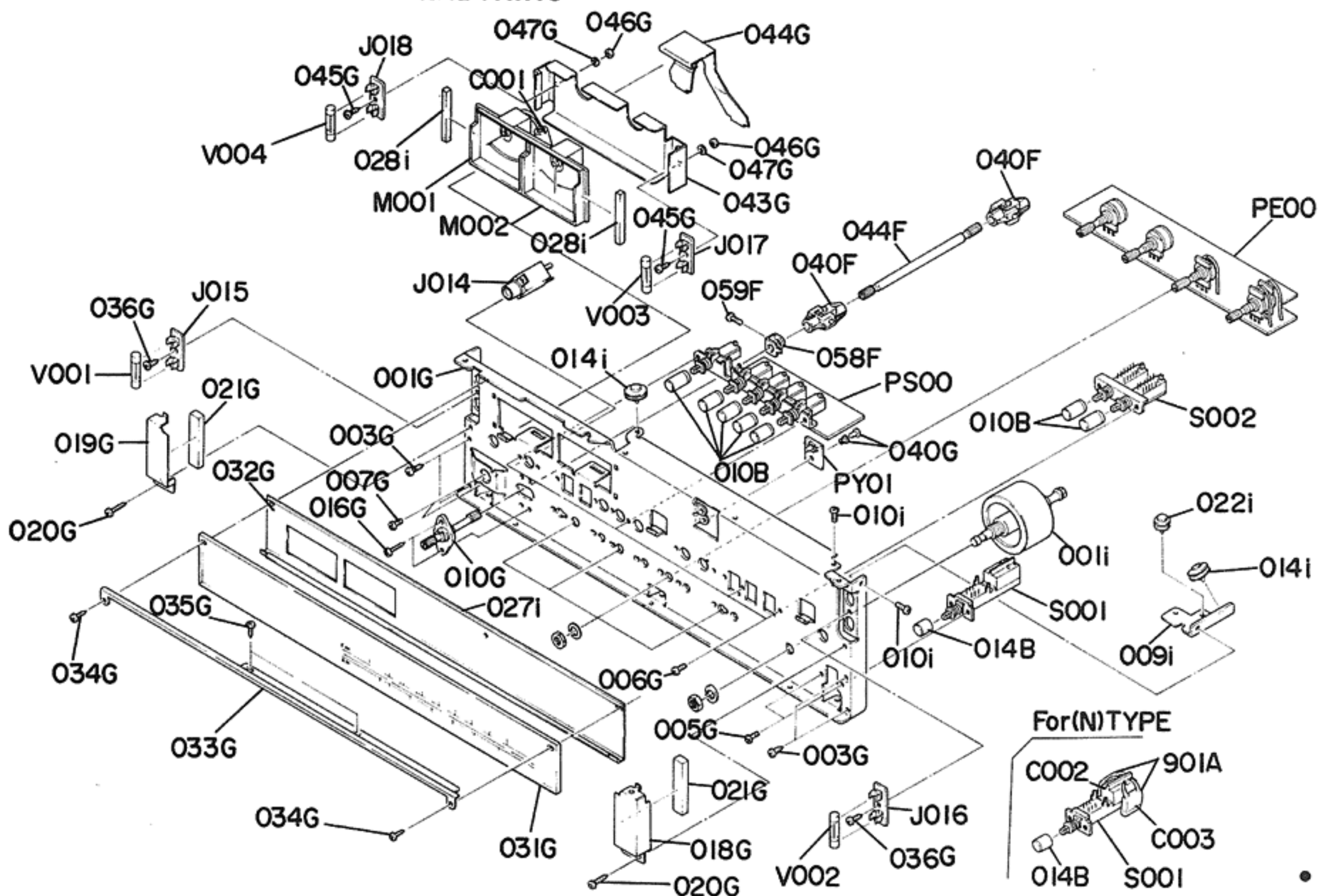

- (U): for U.S.A.
- (C): for Canada
- (N): for Europe

REF. DESIG.	Q'TY			PART NO.	DESCRIPTION
	U	C	N		
010B	7	7	7	2276154120	Knob
014B	1	1	1	2276154040	Knob, Power
040F	2	2	2	2258125510	Joint
044F	1	1	1	2276112040	Shaft
058F	1	1	1	2278114010	Stopper
059F	1	1	1	51064019A9	P.H.M. Screw
001G	1	1	1	2276160012	Bracket
003G	4	4	4	51280308B0	B.T. Tapped Screw B3 x 8
005G	2	2	2	51100306A9	B.H.M. Screw B3 x 6
006G	4	4	4	51100306A9	B.H.M. Screw B3 x 6
007G	2	2	2	51100306A9	B.H.M. Screw B3 x 6
010G	1	1	1	2276112510	Shaft
016G	2	2	2	51280314B0	B.H. Tapped Screw B3 x 14
018G	1	1	1	2276053010	Cover, Dial Lamp (R)
019G	1	1	1	2276053020	Cover, Dial Lamp (L)
020G	2	2	2	51280308B0	B.H. Tapped Screw B3 x 8
021G	2	2	2	2276118010	Spacer
031G	1	1	1	2276302014	Dial
032G	1	1	1	2276063022	Escutcheon
033G	1	1	1	2276005020	Clamper
034G	2	2	2	51280310B0	B.H. Tapped Screw B3 x 10
035G	2	2	2	51280308B0	B.H. Tapped Screw B3 x 8
036G	2	2	2	51280308B0	B.H. Tapped Screw B3 x 8
040G	1	1	1	2276005050	Clamper
043G	1	1	1	2276063030	Escutcheon
044G	1	1	1	2276005010	Clamper

REF. DESIG.	Q'TY			PART NO.	DESCRIPTION
	U	C	N		
045G	2	2	2	51100306A9	B.H.M. Screw B3 x 6
046G	2	2	2	53110303A9	Hexagon Nut
047G	2	2	2	54040302A0	Spring Washer
001i	1	1	1	2276273503	Flywheel
009i	1	1	1	2276160020	Bracket
010i	2	2	2	51100306A9	B.H.M. Screw B3 x 6
014i	2	2	2	2259262500	Pulley
022i	1	1	1	2259262520	Pulley
027i	1	1	1	2276107010	Sheet
028i	2	2	2	2276118030	Spacer
901A			2	3926120010	Insulator
C001	1	1	1	EA47700690	Elect Cap. 470μF 6.3V
C002		1		DF17223800	Film Cap. 0.022μF ±20% 1000V
C003		1		DF17223800	Film Cap. 0.022μF ±20% 1000V
J014	1	1	1	YJ01001200	Jack, Headphone
J015	1	1	1	YJ08000190	Jack
J016	1	1	1	YJ08000190	Jack
J017	1	1	1	YJ08000190	Jack
J018	1	1	1	YJ08000190	Jack
M001	1	1	1	IM11055192	D.C. Meter, Tuning
M002	1	1	1	IM11055202	D.C. Meter, Signal
S001	1	1		SP01010240	Push Switch, Power
S001			1	SP02010330	Push Switch, Power
S002	1	1	1	SP02020420	Push Switch, Speaker
V001	1	1	1	IN10080420	Lamp 0.2A 8V
V002	1	1	1	IN10080420	Lamp 0.2A 8V
V003	1	1	1	IN10080420	Lamp 0.2A 8V
V004	1	1	1	IN10080420	Lamp 0.2A 8V

6.5 [P02-99] ASSEMBLED P.W. BOARD AND OTHER PARTS

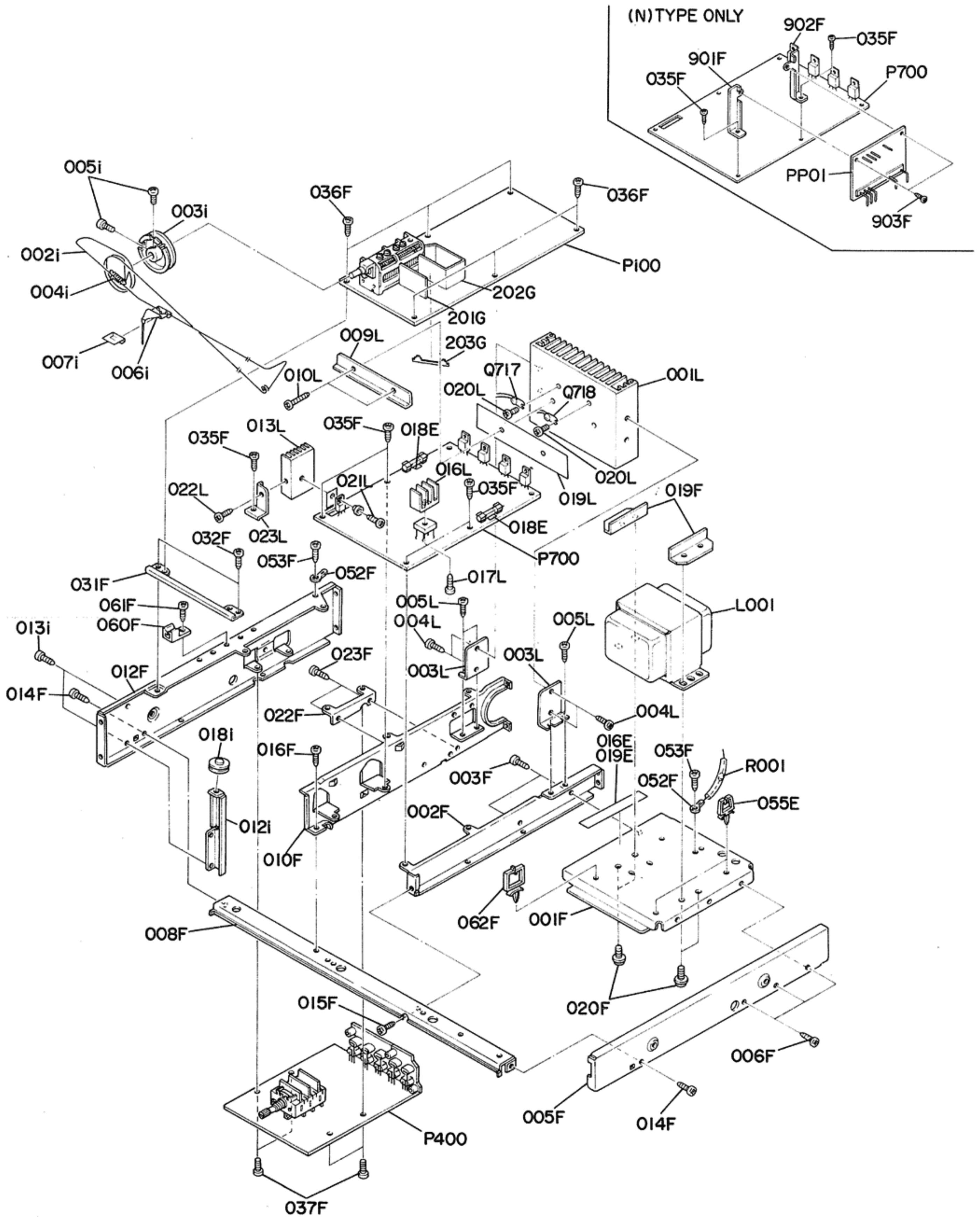



- (U): for U.S.A.
- (C): for Canada
- (N): for Europe

REF. DESIG.	Q'TY			PART NO.	DESCRIPTION
	U	C	N		
016E			1	2205861010	Label
018E			2	2225861020	Label
019E	1			2205861010	Label
019E		1		2225861010	Label
001F	1	1	1	2276105010	Chassis, Transformer
002F	1	1	1	2276105060	Chassis
003F	2	2	2	51280308B0	B.H. Tapped Screw B3 x 8
005F	1	1	1	2276105022	Chassis, (R)
006F	3	3	3	51280308B0	B.H. Tapped Screw B3 x 8
008F	1	1	1	2276105040	Chassis, Front
010F	1	1	1	2276105052	Chassis
012F	1	1	1	2276105034	Chassis, (L)
014F	2	2	2	51280308B0	B.H. Tapped Screw B3 x 8
015F	1	1	1	51280308B0	B.H. Tapped Screw B3 x 8
016F	1	1	1	51280308B0	B.H. Tapped Screw B3 x 8
019F	2	2	2	2276005030	Clamper
020F	4	4	4	51490410A9	L. Washer Screw L4 x 10
022F	1	1	1	2276160060	Bracket
023F	2	2	2	51280308B0	B.H. Tapped Screw B3 x 8
031F	1	1	1	2276160050	Bracket
032F	2	2	2	51280308B0	B.H. Tapped Screw B3 x 8
035F	4	4	4	51280308B0	B.H. Tapped Screw B3 x 8
036F	6	6	6	51280308B0	B.H. Tapped Screw B3 x 8
037F	4	4	4	51280308B0	B.H. Tapped Screw B3 x 8
052F	2	2	2	62030049W0	Lug
053F	3	3	3	51280306B0	B.H. Tapped Screw B3 x 6
055F	2	2	2	2886005050	Clamper
060F	1	1	1	2887005012	Clamper
061F	1	1	1	51280308B0	B.H. Tapped Screw B3 x 8
062F	1	1	1	2886005020	Clamper
901F		1	1	2276160070	Bracket
902F		1	1	2276160080	Bracket
903F		2	2	51280308B0	B.H. Tapped Screw B3 x 8
B	1	1	1	2276159400	Drum Assembly
003i	1	1	1	2276159010	Drum
004i	1	1	1	71101689L0	Spring
005i	2	2	2	51064019A9	P.H.M. Screw

REF. DESIG.	Q'TY			PART NO.	DESCRIPTION
	U	C	N		
002i	1	1	1	72071605A0	String (150)
006i	1	1	1	2259103010	Pointer
007i	1	1	1	2259118010	Spacer
012i	1	1	1	2276160030	Bracket
013i	2	2	2	51100306A9	B.H.M. Screw B3 x 6
018i	1	1	1	2276262500	Pulley
001L	1	1	1	2276267012	Heatsink
003L	2	2	2	2276160040	Bracket
004L	4	4	4	51280308B0	B.H. Tapped Screw B3 x 8
005L	4	4	4	51280308B0	B.H. Tapped Screw B3 x 8
009L	1	1	1	2276005040	Clamper
010L	2	2	2	51280314B0	B.H. Tapped Screw B3 x 14
013L	1	1	1	2276267043	Heatsink
016L	1	1	1	2276267030	Heatsink
017L	1	1	1	51280314B0	B.H. Tapped Screw B3 x 14
019L	1	1	1	2276118020	Spacer
020L	2	2	2	51280306B0	B.H. Tapped Screw B3 x 6
021L	1	1	1	51280308B0	B.H. Tapped Screw B3 x 8
022L	1	1	1	51280306B0	B.H. Tapped Screw B3 x 6
023L	1	1	1	2276160090	Bracket
201G	1	1	1	2259109040	Shield
202G	1	1	1	2259109053	Shield
203G	1	1	1	2259109062	Shield
L001	1			TS17402010	Power Transformer
L001		1		TS17402020	Power Transformer
L001			1	TS17402032	Power Transformer
R001	1	1		RC10225120	Resistor 2.2MΩ ±10% ½W
Q717	1	1	1	HV00008120	Varistor MV-1Y
Q718	1	1	1	HV00008120	Varistor MV-1Y

6.6 [H01-99] PACKING MATERIALS

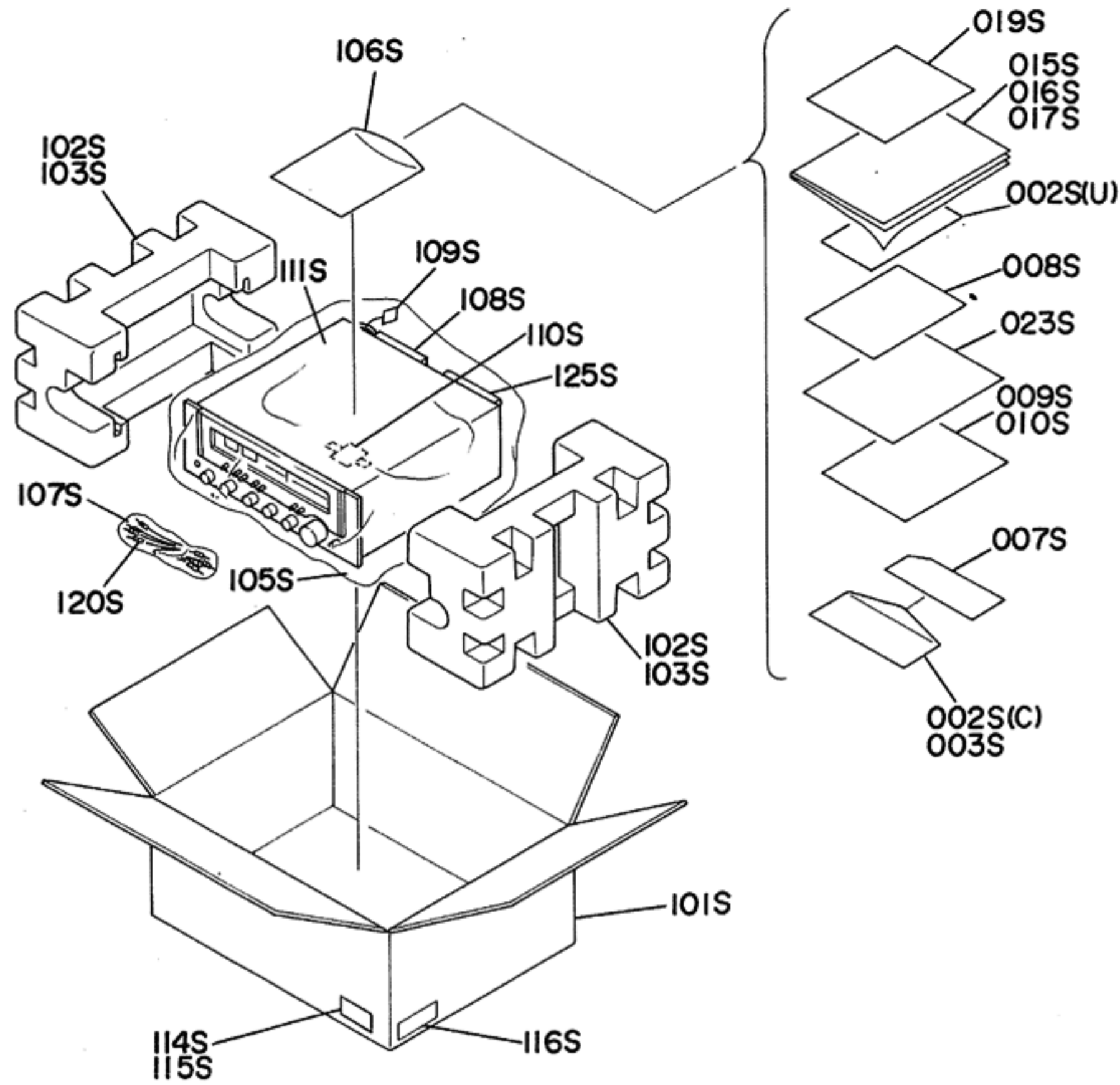

- (U): for U.S.A.
- (C): for Canada
- (N): for Europe

REF. DESIG.	Q'TY			PART NO.	DESCRIPTION
	U	C	N		
002S	1			2225813010	Envelope
002S		1		2918813012	Envelope
003S			1	2818813010	Envelope
007S		1	1	9630000180	Guarantee Card
008S		1		9650000053	S. Station Card
009S	1			2818854024	Guarantee Card
010S		1		2818854042	Guarantee Card
015S	1			2276851012	Instructions
016S			1	2276851310	Instructions (M1515, ONLY)
016S			1	2468851310	Instructions (MR215, ONLY)
017S		1		2276851012	Instructions
019S	1	1		2276851020	Instructions
019S			1	2468851030	Instructions
023S		1		2886851100	Instructions
101S	1		1	2276801013	Packing Case
101S		1		2276801152	Packing Case
101S			1	2468801012	Packing Case (MR215, ONLY)
102S			2	2276809020	Cushion (M1515, ONLY)
102S			2	2276809010	Cushion (MR215, ONLY)
103S	2	2		2276809020	Cushion
103S	2			2276809010	Cushion (MR220, ONLY)
019S	1			2276851122	Instructions (MR220, ONLY)
101S	1			2276801022	Packing Case (MR220, ONLY)

REF. DESIG.	Q'TY			PART NO.	DESCRIPTION
	U	C	N		
105S	1	1		9090909040	Polyethy Bag
105S	1	1	1	9014838380	Polyethy Bag
106S	1	1	1	9013025010	Polyethy Bag
107S	1	1	1	9011325010	Polyethy Bag
108S	1	1	1	2864804010	Sleeve
109S			1	9560000043	Hang Tag
110S			1	2731821010	Silicagel
111S	1	1	1	2918107130	Sheet
114S	3			9526019010	Serial No. Card
114S		3		9526019020	Serial No. Card
115S			3	9526019060	Serial No. Card
116S		2		9510901020	Label
120S	1	1	1	ZA02000070	EXT. Antenna
125S	1	1	1	2819056010	Buffer
					M1515 (U)(C)(N) MR215 (N), ONLY MR220 (U), ONLY



6.7 ELECTRICAL PARTS

• (U): for U.S.A.  
• (C): for Canada  
• (N): for Europe

REF. DESIG.	Q'TY			PART NO.	DESCRIPTION
	U	C	N		
P100	1	1	1	YG22590010	<b>M1515, ONLY</b> <b>P100-TUNER CIRCUIT BOARD</b> P.W. Board, Tuner
	1	1		ZZ22761010	P.W. Board Assembly
			1	ZZ22768110	P.W. Board Assembly
P100			1	YG22590012	<b>MR215, ONLY</b> <b>P100-TUNER CIRCUIT BOARD</b> P.W. Board, Tuner
			1	ZZ22768110	P.W. Board Assembly
					<b>P100-CAPACITORS</b>
C101	1	1	1	DD15180370	Ceramic 18pF ±5%
C102	1	1	1	DK16102300	Ceramic 0.001μF ±10%
C104	1	1	1	DK17103300	Ceramic 0.01μF ±20%
C105	1	1	1	DD15180370	Ceramic 18pF ±5%
C106	1	1	1	DD10030370	Ceramic 3pF ±0.5pF
C107	1	1	1	DD10050370	Ceramic 5pF ±0.25pF
C108	1	1	1	DD15301360	Ceramic 300pF ±5%
C109	1	1	1	DK17103300	Ceramic 0.01μF ±20%
C110	1	1	1	DD15200330	Ceramic 20pF ±5%
C111	1	1	1	DD11100300	Ceramic 10pF ±0.5pF
C112	1	1	1	DD15150300	Ceramic 15pF ±5%
C113	1	1	1	DD15150300	Ceramic 15pF ±5%
C114	1	1	1	DK17103300	Ceramic 0.01μF ±20%
C115	1	1	1	DD10020370	Ceramic 2pF ±0.25pF
C116	1	1	1	DK17103300	Ceramic 0.01μF ±20%
C117	1	1	1	DK17103300	Ceramic 0.01μF ±20%
C118	1	1	1	DK17103300	Ceramic 0.01μF ±20%
C119	1	1	1	CT11000080	Trimming 10pF ±0.5pF
C120	1	1	1	CA32400090	Variable C752J
C151	1	1	1	DF55361090	Film 360pF ±5%
C152	1	1	1	DD10050370	Ceramic 5pF ±0.25pF
C153	1	1	1	EA10701690	Elect 100μF 16V
C154	1	1	1	DK18403320	Ceramic 0.04μF +80%—20%
C155	1	1	1	EA33601690	Elect 33μF 16V
C156	1	1	1	DK18223310	Ceramic 0.022μF +80%—20%
C157	1	1	1	DD15820370	Ceramic 82pF ±5%
C201	1	1	1	DK17103300	Ceramic 0.01μF ±20%
C202	1	1	1	DK17103300	Ceramic 0.01μF ±20%
C203	1	1	1	DK17103300	Ceramic 0.01μF ±20%
C204	1	1	1	DK17103300	Ceramic 0.01μF ±20%
C205	1	1	1	DK18403320	Ceramic 0.04μF +80%—20%
C206	1	1	1	DK18403320	Ceramic 0.04μF +80%—20%
C207	1	1	1	DK18403320	Ceramic 0.04μF +80%—20%
C208	1	1	1	DK17103300	Ceramic 0.01μF ±20%
C209	1	1	1	DK17103300	Ceramic 0.01μF ±20%
C210	1	1	1	DD15201360	Ceramic 200pF ±5%
C211	1	1	1	DK17103300	Ceramic 0.01μF ±20%
C212	1	1	1	DK18403320	Ceramic 0.04μF +80%—20%
C213	1	1	1	DK17103300	Ceramic 0.01μF ±20%
C214	1	1	1	DK17103300	Ceramic 0.01μF ±20%
C215	1	1	1	EA33502590	Elect 3.3μF 25V
C216	1	1	1	DK18223310	Ceramic 0.022μF +80%—20%
C217	1	1	1	EA47503590	Elect 4.7μF 35V
C218	1	1	1	EA22701690	Elect 220μF 16V
C219	1	1	1	DK17103300	Ceramic 0.01μF ±20%
C220	1	1	1	DK81040200	Ceramic 0.1μF ±20%

REF. DESIG.	Q'TY			PART NO.	DESCRIPTION
	U	C	N		
C221	1	1	1	DK17103300	Ceramic 0.01μF ±20%
C222	1	1	1	EA10505090	Elect 1μF 50V
C223	1	1	1	EA47405090	Elect 0.047μF 50V
C224	1	1	1	EA10601690	Elect 10μF 16V
C225	1	1	1	DF15182300	Film 1800pF ±5%
C226	1	1	1	EA10601690	Elect 10μF 16V
C227	1	1	1	EA10505090	Elect 1μF 50V
C228	1	1	1	DK18403320	Ceramic 0.04μF +80%—20%
C229	1	1	1	DF55102090	Film 1000pF ±5%
C230	1	1	1	DK17103300	Ceramic 0.01μF ±20%
C231	1	1	1	EA10601690	Elect 10μF 16V
C233	1	1	1	DK17103300	Ceramic 0.01μF ±20%
C234	1	1	1	DK17103300	Ceramic 0.01μF ±20%
C235	1	1	1	EA22701690	Elect 220μF 16V
C301	1	1	1	EE10505050	Elect 1μF 50V
C302	1	1	1	EE10505050	Elect 1μF 50V
C303	1	1	1	DF15332300	Film 0.0033μF ±5%
C304	1	1	1	DF15332300	Film 0.0033μF ±5%
C305	1	1	1	EA22502590	Elect 2.2μF 25V
C306	1	1	1	EA22502590	Elect 2.2μF 25V
C307	1	1	1	EE47502590	Elect 4.7μF 25V
C308	1	1	1	EE47502590	Elect 4.7μF 25V
C309	1	1	1	EA10701690	Elect 100μF 16V
C311	1	1	1	EE10505050	Elect 1μF 50V
C312	1	1	1	EE10405050	Elect 0.1μF 50V
C313	1	1	1	EA10505090	Elect 1μF 50V
C314	1	1	1	EA22601690	Elect 22μF 16V
C315	1	1	1	EA10601690	Elect 10μF 16V
					<b>P100-RESISTORS</b> (All Resistors are ±5% and ¼W)
R101	1	1	1	GD05105140	1MΩ
R102	1	1	1	GD05101140	100Ω
R103	1	1	1	GD05101140	100Ω
R104	1	1	1	GD05472140	4.7KΩ
R105	1	1	1	GD05223140	22KΩ
R106	1	1	1	GD05102140	1KΩ
R107	1	1	1	GD05103140	10KΩ
R108	1	1	1	GD05103140	10KΩ
R109	1	1	1	GD05152140	1.5KΩ
R110	1	1	1	GD05101140	100Ω
R111	1	1	1	GD05273140	27KΩ
R112	1	1	1	GG05101140	100Ω
R113	1	1	1	GD05221140	220Ω
R114	1	1	1	GD05104140	100KΩ
R151	1	1	1	GD05202140	2KΩ
R201	1	1	1	GD05151140	150Ω
R202	1	1	1	GD05272140	2.7KΩ
R203	1	1	1	GD05153140	15KΩ
R204	1	1	1	GD05471140	470Ω
R205	1	1	1	GD05331140	330Ω
R206	1	1	1	GD05331140	330Ω
R207	1	1	1	GD05272140	2.7KΩ
R208	1	1	1	GD05153140	15KΩ
R209	1	1	1	GD05471140	470Ω
R210	1	1	1	GD05331140	330Ω



- (U): for U.S.A.
- (C): for Canada
- (N): for Europe

REF. DESIG.	Q'TY			PART NO.	DESCRIPTION	
	U	C	N			
R211	1	1	1	GD05331140	330Ω	
R212	1	1	1	GD05151140	150Ω	
R213	1	1	1	GD05472140	4.7KΩ	
R214	1	1	1	GD05103140	10KΩ	
R215	1	1	1	GD05102140	1KΩ	
R216	1	1	1	GD05202140	2KΩ	
R217	1	1	1	GD05563140	56KΩ	
R218	1	1	1	GD05333140	33KΩ	
R219	1	1	1	GD05224140	220KΩ	
R220	1	1	1	GD05470140	47Ω	
R221	1	1	1	GD05470140	47Ω	
R222	1	1	1	GD05221140	220Ω	
R223	1	1	1	GD05391140	390Ω	
R224	1	1	1	GD05562140	5.6KΩ	
R225	1	1	1	GD05332140	3.3KΩ	
R226	1	1	1	GD05823140	82KΩ	
R227	1	1	1	GD05333140	33KΩ	
R228	1	1	1	RA02030060	Trimming	20KΩ
R229	1	1	1	GD05472140	4.7KΩ	
R230	1	1	1	GD05822140	8.2KΩ	
R231	1	1	1	GD05391140	390Ω	
R232	1	1	1	RA03020030	Trimming	3KΩ (B)
R233	1	1	1	RA05020160	Trimming	5KΩ
R235	1	1	1	GD05473140	47KΩ	
R236	1	1	1	GD05151140	150Ω	
R237	1	1	1	GD05821140	820Ω	
R238	1	1	1	GD05563140	56KΩ	
R239	1	1	1	GD05104140	100KΩ	
R240	1	1	1	GD05104140	100KΩ	
R241	1	1	1	GD05152140	1.5KΩ	
R242	1	1	1	GD05473140	47KΩ	
R243	1	1	1	GD05104140	100KΩ	
R244	1	1	1	GD05153140	15KΩ	
R245	1	1	1	GD05153140	15KΩ	
R246	1	1	1	GD05104140	100KΩ	
R248	1	1	1	GD05222140	2.2KΩ	
R250	1	1	1	GD05123140	12KΩ	
R251	1	1	1	GD05244140	240KΩ	
R252	1	1	1	GD05104140	100KΩ	
R255	1	1	1	GD05100140	10Ω	
R256	1	1	1	GD05153140	15KΩ	
R257	1	1	1	GD05103140	10KΩ	
R258	1	1	1	GD05271140	270Ω	
R301	1	1	1	GD05472140	4.7KΩ	
R302	1	1	1	GD05472140	4.7KΩ	
R303	1	1	1	GD05472140	4.7KΩ	
R304	1	1	1	GD05472140	4.7KΩ	
R305	1	1		GD05303140	30KΩ	
R305			1	GD05183140	18KΩ	
R306	1	1		GD05303140	30KΩ	
R306			1	GD05183140	18KΩ	
R307	1	1	1	GD05105140	1MΩ	
R308	1	1	1	GD05105140	1MΩ	

REF. DESIG.	Q'TY			PART NO.	DESCRIPTION	
	U	C	N			
R309	1	1		GD05204140	200KΩ	
R309			1	GD05154140	150KΩ	
R310	1	1		GD05204140	200KΩ	
R310			1	GD05154140	150KΩ	
R311	1	1	1	GD05472140	4.7KΩ	
R312	1	1	1	GD05472140	4.7KΩ	
R313	1	1		GD05301140	300Ω	
R313			1	GD05241140	240Ω	
R314	1	1		GD05301140	300Ω	
R314			1	GD05241140	240Ω	
R315	1	1	1	GD05102140	1KΩ	
R316	1	1	1	RA01030260	Trimming	10KΩ
R317	1	1	1	GD05473140	47KΩ	
R318	1	1	1	GD05473140	47KΩ	
R319	1	1	1	GD05101140	100Ω	
R320	1	1	1	GD05101140	100Ω	
R321	1	1	1	GD05101140	100Ω	
R325	1	1	1	GD05562140	5.6KΩ	
R326	1	1	1	RA04720050	Trimming	4.7KΩ (B)
R327	1	1	1	GD05103140	10KΩ	
R328	1	1	1	GD05102140	1KΩ	
R329	1	1	1	GD05102140	1KΩ	
R330	1	1	1	GD05103140	10KΩ	
R331	1	1	1	GD05101140	100Ω	
R332	1	1	1	GD05103140	10KΩ	
R333	1	1	1	GD05104140	100KΩ	
R334	1	1	1	GD05104140	100KΩ	
<b>P100-SEMICONDUCTORS</b>						
Q101	1	1	1	HF400451B0	F.E.T.	2SK45 (B)
Q102	1	1	1	HT305352B0	Transistor	2SC535 (B or C)
Q103	1	1	1	HT308291C0	Transistor	2SC829 (C)
Q151	1	1	1	HD20001210	Diode	1S2473C
Q152	1	1	1	HD20001210	Diode	1S2473C
Q201	1	1	1	HT308291C0	Transistor	2SC829 (C)
Q202	1	1	1	HT308291C0	Transistor	2SC829 (C)
Q203	1	1	1	HT308291C0	Transistor	2SC829 (C)
Q204	1	1	1	HD10003020	Diode	20A90M
Q205	1	1	1	HD10003020	Diode	20A90M
Q206	1	1	1	HC10009020	IC	AN7000
Q207	1	1	1	HT308291C0	Transistor	2SC829 (C)
Q208	1	1	1	HD10003020	Diode	20A90M
Q209	1	1	1	HD20001210	Diode	1S2473C
Q210	1	1	1	HT308281D0	Transistor	2SC828 (S)
Q211	1	1	1	HT308281D0	Transistor	2SC828 (S)
Q212	1	1	1	HT107222A0	Transistor	2SA722 (S or T)
Q214	1	1	1	HD10003020	Diode	20A90M
Q301	1	1	1	HT308281D0	Transistor	2SC828 (S)
Q302	1	1	1	HT308281D0	Transistor	2SC828 (S)
Q310	1	1	1	HD10003020	Diode	20A90M
Q311	1	1	1	HT107222A0	Transistor	2SA722 (S or T)



- (U): for U.S.A.
- (C): for Canada
- (N): for Europe

REF. DESIG.	Q'TY			PART NO.	DESCRIPTION
	U	C	N		
<b>P100-MISCELLANEOUS</b>					
F151	1	1	1	FF10045180	Ceramic Filter AM
F201	1	1	1	FF11070050	Ceramic Filter FM SFE10.7MD1
F202	1	1	1	FF11070050	Ceramic Filter FM SFE10.7MD1
F203	1	1	1	FF11070050	Ceramic Filter FM SFE10.7MD1
L101	1	1	1	LA12026170	Ant. Coil FM
L102	1	1	1	LA12026180	Ant. Coil FM
L103	1	1	1	LO12036010	OSC Coil FM
L104	1	1	1	LI10016010	I.F.T. FM
L105	1	1	1	LC13320020	Choke Coil 3.3 $\mu$ H
L106	1	1	1	LC17510010	Choke Coil 0.75 $\mu$ H
L151	1	1	1	LC13320020	Choke Coil 3.3 $\mu$ H
L152	1	1	1	LC13320020	Choke Coil 3.3 $\mu$ H
L153	1	1	1	LO10010530	OSC Coil AM
L154	1	1	1	LI10010710	I.F.T. AM
L201	1	1	1	LI14016240	I.F.T. FM Det
L202	1	1	1	LC11830020	Choke Coil 18 $\mu$ H
L203	1	1	1	LC23960020	Choke Coil 39mH
L204	1	1	1	LC12250030	Choke Coil 2200 $\mu$ H
L205	1	1	1	LC11030020	Choke Coil 10 $\mu$ H
L301	1	1	1	LS20010010	M.P.X. Coil
L302	1	1	1	LS20010010	M.P.X. Coil
<b>P400-PHONO CIRCUIT BOARD</b>					
P400	1	1	1	YG22760020	P.W. Board, Phono
	1	1	1	ZZ22760020	P.W. Board Assembly
<b>P400-CAPACITORS</b>					
CV01	1	1	1	DK17103300	Ceramic 0.01 $\mu$ F $\pm$ 20%
CV02	1	1	1	DK17103300	Ceramic 0.01 $\mu$ F $\pm$ 20%
C401	1	1	1	EE33502550	Elect 3.3 $\mu$ F 25V
C402	1	1	1	EE33502550	Elect 3.3 $\mu$ F 25V
C403	1	1	1	DD15470360	Ceramic 47pF $\pm$ 5%
C404	1	1	1	DD15470360	Ceramic 47pF $\pm$ 5%
C405	1	1	1	EA10701090	Elect 100 $\mu$ F 10V
C406	1	1	1	EA10701090	Elect 100 $\mu$ F 10V
C407	1	1	1	DK16221300	Ceramic 220pF $\pm$ 10%
C408	1	1	1	DK16221300	Ceramic 220pF $\pm$ 10%
C409	1	1	1	DF15123300	Film 0.012 $\mu$ F $\pm$ 5%
C410	1	1	1	DF15123300	Film 0.012 $\mu$ F $\pm$ 5%
C411	1	1	1	DF15332300	Film 3300pF $\pm$ 5%
C412	1	1	1	DF15332300	Film 3300pF $\pm$ 5%
C413	1	1	1	EA10505090	Elect 1 $\mu$ F 50V
C414	1	1	1	EA10705090	Elect 100 $\mu$ F 50V
C415	1	1	1	EA10505090	Elect 1 $\mu$ F 50V
C416	1	1	1	EA10505090	Elect 1 $\mu$ F 50V
C417	1	1	1	DD15220360	Ceramic 22pF $\pm$ 5%
C418	1	1	1	DD15220360	Ceramic 22pF $\pm$ 5%
C419	1	1	1	DK16332300	Ceramic 0.0033 $\mu$ F $\pm$ 10%
C420	1	1	1	DK16332300	Ceramic 0.0033 $\mu$ F $\pm$ 10%
CM01	1	1	1	EA10703590	Elect 100 $\mu$ F 35V
CM02	1	1	1	EA10701090	Elect 100 $\mu$ F 10V
CM03	1	1	1	EA10603590	Elect 10 $\mu$ F 35V
CM04	1	1	1	DK18103310	Ceramic 0.01 $\mu$ F +80%-0

REF. DESIG.	Q'TY			PART NO.	DESCRIPTION
	U	C	N		
<b>P400-RESISTORS</b> (All Resistors are $\pm$ 5% and $\frac{1}{2}$ W)					
RV01	1	1	1	GD05272140	2.7K $\Omega$
RV02	1	1	1	GD05152140	1.5K $\Omega$
RV03	1	1	1	GD05561120	560 $\Omega$ $\frac{1}{2}$ W
R401	1	1	1	GD05102140	1K $\Omega$
R402	1	1	1	GD05102140	1K $\Omega$
R403	1	1	1	GD05471140	470 $\Omega$
R404	1	1	1	GD05471140	470 $\Omega$
R405	1	1	1	GD05623140	62K $\Omega$
R406	1	1	1	GD05623140	62K $\Omega$
R407	1	1	1	GD05274140	270K $\Omega$
R408	1	1	1	GD05274140	270K $\Omega$
R409	1	1	1	GD05184140	180K $\Omega$
R410	1	1	1	GD05184140	180K $\Omega$
R411	1	1	1	GD05274140	270K $\Omega$
R412	1	1	1	GD05274140	270K $\Omega$
R413	1	1	1	GD05223140	22K $\Omega$
R414	1	1	1	GD05223140	22K $\Omega$
R415	1	1	1	GD05681140	880 $\Omega$
R416	1	1	1	GD05681140	680 $\Omega$
R417	1	1	1	GD05224140	220K $\Omega$
R418	1	1	1	GD05224140	220K $\Omega$
R419	1	1	1	GD05223140	22K $\Omega$
R420	1	1	1	GD05223140	22K $\Omega$
R421	1	1	1	GD05221140	220 $\Omega$
R422	1	1	1	GD05184140	180K $\Omega$
R423	1	1	1	GD05151140	150 $\Omega$
R424	1	1	1	GD05151140	150 $\Omega$
RM01	1	1	1	GD05333140	33K $\Omega$
RM02	1	1	1	GD05103140	10K $\Omega$
RM03	1	1	1	GD05474140	470K $\Omega$
RM04	1	1	1	GD05100140	10 $\Omega$
RM05	1	1	1	GD05273140	27K $\Omega$
RM06	1	1	1	GD05153140	15K $\Omega$
RM07	1	1	1	GD05272140	2.7K $\Omega$
RM08	1	1	1	GD05103140	10K $\Omega$
<b>P400-SEMICONDUCTORS</b>					
Q401	1	1	1	HC10012060	IC $\mu$ PC1024H
Q402	1	1	1	HC10012060	IC $\mu$ PC1024H
QM01	1	1	1	HD20011050	Diode 1S1555
QM02	1	1	1	HT309452A0	Transistor 2SC945 (Q or R)
QM03	1	1	1	HT309452A0	Transistor 2SC945 (Q or R)
QM04	1	1	1	HT309452A0	Transistor 2SC945 (Q or R)
<b>P400-MISCELLANEOUS</b>					
JV01	1	1	1	YT02060140	Terminal, Phono Aux 1, 2
JV02	1	1	1	YT02040280	Terminal, Tape 1
SV01	1	1	1	SR06050180	Rotary Switch



- (U): for U.S.A.
- (C): for Canada
- (N): for Europe

REF. DEISG.	Q'TY			PART NO.	DESCRIPTION
	U	C	N		
P700	1	1	1	YG22760012	<b>P700-MAIN AMP./POWER SUPPLY CIRCUIT BOARD</b> P.W. Board, Main Amp./ Power Supply
	1	1		ZZ22760010	P.W. Board Assembly
			1	ZZ22768010	P.W. Board Assembly
<b>P700-CAPACITORS</b>					
C701	1	1	1	DD15201360	Ceramic 200pF ±5%
C702	1	1	1	DD15201360	Ceramic 200pF ±5%
C703	1	1	1	EE22505050	Elect 2.2μF 50V
C704	1	1	1	EE22505050	Elect 2.2μF 50V
C705	1	1	1	EE47601050	Elect 47μF 10V
C706	1	1	1	EE47601050	Elect 47μF 10V
C711	1	1	1	DD10050360	Ceramic 5pF ±0.25pF
C712	1	1	1	DD10050360	Ceramic 5pF ±0.25pF
C713	1	1	1	DF17104300	Film 0.1μF ±20%
C714	1	1	1	DF17104300	Film 0.1μF ±20%
C719	1	1	1	DK16102300	Ceramic 1000pF ±10%
C720	1	1	1	DK16102300	Ceramic 1000pF ±10%
C721	1	1	1	DK16102300	Ceramic 1000pF ±10%
C722	1	1	1	DK16102300	Ceramic 1000pF ±10%
C723	1	1	1	DF17104540	Film 0.1μF ±20% 100V
C724	1	1	1	DF17104540	Film 0.1μF ±20% 100V
C729	1	1	1	EA10703590	Elect 100μF 35V
C730	1	1	1	EA10703590	Elect 100μF 35V
C731	1	1	1	DD15510360	Ceramic 51pF ±5%
C732	1	1	1	DD15510360	Ceramic 51pF ±5%
C733	1	1	1	DD15510360	Ceramic 51pF ±5%
C734	1	1	1	DD15510360	Ceramic 51pF ±5%
C735	1	1	1	DK18103320	Ceramic 0.01μF +80% -0
C801	1	1	1	EB68803550	Elect 6800μF 35V
C802	1	1	1	EB68803550	Elect 6800μF 35V
C803	1	1	1	DK18103510	Ceramic 0.01μF +80% -0
C804	1	1	1	DK18103510	Ceramic 0.01μF +80% -0
C805	1	1	1	EA47705090	Elect 470μF 50V
C806	1	1	1	EA47705090	Elect 470μF 50V
C807	1	1	1	DK17103300	Ceramic 0.01μF ±10%
C808	1	1	1	DK17103300	Ceramic 0.01μF ±10%
C809	1	1	1	EA10603590	Elect 10μF 35V
C810	1	1	1	EA10603590	Elect 10μF 35V
C811	1	1	1	EA47701690	Elect 470μF 16V
C816	1	1	1	DR17103300	Ceramic 0.01μF ±10%
C818	1	1	1	EQ10601610	Elect 10μF 16V
C819	1	1	1	DK18103510	Ceramic 0.01μF +80% -0
<b>P700-RESISTORS</b> (All Resistors are ±5% and ¼W)					
R701	1	1	1	GD05102140	1KΩ
R702	1	1	1	GD05102140	1KΩ
R703	1	1	1	GD05104140	100KΩ
R704	1	1	1	GD05104140	100KΩ
R705	1	1	1	GD05681140	680Ω
R706	1	1	1	GD05681140	680Ω
R707	1	1	1	GD05914140	910KΩ
R708	1	1	1	GD05914140	910KΩ
R709	1	1	1	GD05105140	1MΩ
R710	1	1	1	GD05105140	1MΩ

REF. DESIG.	Q'TY			PART NO.	DESCRIPTION
	U	C	N		
R711	1	1	1	GD05222140	2.2KΩ
R712	1	1	1	GD05222140	2.2KΩ
R713	1	1	1	GD05152140	1.5KΩ
R714	1	1	1	GD05152140	1.5KΩ
R717	1	1	1	RA01020250	Trimming 1KΩ
R718	1	1	1	RA01020250	Trimming 1KΩ
R721	1	1	1	GD05104140	100KΩ
R722	1	1	1	GD05104140	100KΩ
R723	1	1	1	GD05822140	8.2KΩ
R724	1	1	1	GD05822140	8.2KΩ
R725	1	1	1	GD05123140	12KΩ
R726	1	1	1	GD05123140	12KΩ
R727	1	1	1	GD05823140	82KΩ
R728	1	1	1	GD05823140	82KΩ
R729	1	1	1	GD05823140	82KΩ
R730	1	1	1	GD05823140	82KΩ
R733	1	1	1	GG05102140	1KΩ
R734	1	1	1	GG05102140	1KΩ
R735	1	1	1	GG05102140	1KΩ
R736	1	1	1	GG05102140	1KΩ
R737	1	1	1	GG05101140	100Ω
R738	1	1	1	GG05101140	100Ω
R739	1	1	1	GG05101140	100Ω
R740	1	1	1	GG05101140	100Ω
R741	1	1		GB05472020	0.47Ω 2W
R741			1	GK05472020	0.47Ω 2W
R742	1	1		GB05472020	0.47Ω 2W
R742			1	GK05472020	0.47Ω 2W
R743	1	1		GB05472020	0.47Ω 2W
R743			1	GK05472020	0.47Ω 2W
R744	1	1		GB05472020	0.47Ω 2W
R744			1	GK05472020	0.47Ω 2W
R745	1	1	1	GG05100120	10Ω ½W
R746	1	1	1	GG05100120	10Ω ½W
R747	1	1	1	RC10022120	2.2Ω ±10% ½W
R748	1	1	1	RC10022120	2.2Ω ±10% ½W
R749	1	1	1	GA05331010	330Ω 1W
R750	1	1	1	GA05331010	330Ω 1W
R751	1	1	1	GG05151120	150Ω ½W
R752	1	1	1	GG05151120	150Ω ½W
R753	1	1	1	GG05101140	100Ω
R754	1	1	1	GG05101140	100Ω
R755	1	1	1	GD05683140	68KΩ
R756	1	1	1	GD05683140	68KΩ
R757	1	1	1	GD05123140	12KΩ
R758	1	1	1	GD05123140	12KΩ
R759	1	1	1	GD05102140	1KΩ
R760	1	1	1	GD05102140	1KΩ
R801	1	1	1	GP05151030	150Ω 3W
R802	1	1	1	GG05152140	1.5KΩ
R803	1	1	1	GG05102140	1KΩ
R804	1	1	1	GD05103140	10KΩ
R805	1	1	1	GD05682140	6.8KΩ
R806	1	1	1	GD05242140	2.4KΩ



- (U): for U.S.A.
- (C): for Canada
- (N): for Europe

REF. DEISG.	Q'TY			PART NO.	DESCRIPTION
	U	C	N		
<b>P700-SEMICONDUCTORS</b>					
Q701	1	1	1	HC10002360	IC LM391N-60
Q702	1	1	1	HC10002360	IC LM291N-60
Q703	1	1	1	HT313842F0	Transistor 2SC1384 (Q or R)
Q704	1	1	1	HT313842F0	Transistor 2SC1384 (Q or R)
Q705	1	1	1	HT106842F0	Transistor 2SA684 (Q or R)
Q706	1	1	1	HT106842F0	Transistor 2SA684 (Q or R)
Q707	1	1	1	HT205072A0	Transistor 2SB507 (D or E)
Q708	1	1	1	HT205072A0	Transistor 2SB507 (D or E)
Q709	1	1	1	HT403132A0	Transistor 2SD313 (D or E)
Q710	1	1	1	HT403132A0	Transistor 2SD313 (D or E)
Q711	1	1	1	HD20005010	Diode W06B
Q712	1	1	1	HD20005010	Diode W06B
Q713	1	1	1	HD20005010	Diode W06B
Q714	1	1	1	HD20005010	Diode W06B
Q717	1	1	1	HV00008120	Varistor MV-1Y
Q718	1	1	1	HV00008120	Varistor MV-1Y
Q719	1	1	1	HD20003210	Diode 1S2471
Q720	1	1	1	HD20003210	Diode 1S2471
Q721	1	1	1	HD20003210	Diode 1S2471
Q722	1	1	1	HD20003210	Diode 1S2471
Q801	1	1	1	HD20022100	Diode 10E1
Q803	1	1	1	HD20008290	Diode S4VB
Q804	1	1	1	HD20022100	Diode 10E1
Q805	1	1	1	HT403131Q0	Transistor 2SD313 (E)
Q806	1	1	1	HT309452A0	Transistor 2SC945 (Q or R)
Q807	1	1	1	HD30022090	Zener BZ-120
<b>P700-MISCELLANEOUS</b>					
L701	1	1	1	LL23915120	Choke Coil
L702	1	1	1	LL23915120	Choke Coil
F701	1	1		FS10350010	Fuse 3.5A 250V
F701			1	FS10350800	Fuse 3.5AT 250V
F702	1	1		FS10350010	Fuse 3.5A 250V
F702			1	FS10350800	Fuse 3.5AT 250V
J701					
?	4	4		YJ08000170	Jack, Fuse Holder
J704					
J701					
?			4	YJ08000270	Jack, Fuse Holder
J704					
<b>PC00-ANTENNA CIRCUIT BOARD</b>					
PC00	1	1	1	YH22760210	P.W. Board, Antenna
	1	1	1	ZZ22760210	P.W. Board Assembly
JC01	1	1	1	YT01040182	Terminal
LC01	1	1	1	LB30075260	Balun Coil

REF. DESIG.	Q'TY			PART NO.	DESCRIPTION
	U	C	N		
<b>PE00-TONE AMP. CIRCUIT BOARD</b>					
PE00	1	1	1	YK22761210	P.W. Board, Tone Amp.
	1	1	1	ZZ22761210	P.W. Board Assembly
<b>PE00-CAPACITORS</b>					
CE01	1	1	1	EE10405050	Elect 0.1 $\mu$ F 50V
CE02	1	1	1	EE10405050	Elect 0.1 $\mu$ F 50V
CE03	1	1	1	EA10701090	Elect 100 $\mu$ F 10V
CE04	1	1	1	DD15201360	Ceramic 200pF $\pm$ 5%
CE05	1	1	1	DD15201360	Ceramic 200pF $\pm$ 5%
CE06	1	1	1	EE47505050	Elect 4.7 $\mu$ F 50V
CE07	1	1	1	EE47505050	Elect 4.7 $\mu$ F 50V
CE08	1	1	1	DF16333300	Film 0.033 $\mu$ F $\pm$ 10%
CE09	1	1	1	DF16333300	Film 0.033 $\mu$ F $\pm$ 10%
CE10	1	1	1	DF16333300	Film 0.033 $\mu$ F $\pm$ 10%
CE11	1	1	1	DF16333300	Film 0.033 $\mu$ F $\pm$ 10%
CE12	1	1	1	DF16182300	Film 1800pF $\pm$ 10%
CE13	1	1	1	DF16182300	Film 1800pF $\pm$ 10%
CE14	1	1	1	DD15391360	Ceramic 390pF $\pm$ 5%
CE15	1	1	1	DD15391360	Ceramic 390pF $\pm$ 5%
CE16	1	1	1	EE10405050	Elect 0.1 $\mu$ F 50V
CE17	1	1	1	EE10405050	Elect 0.1 $\mu$ F 50V
CE18	1	1	1	DD10050370	Ceramic 5pF $\pm$ 0.25pF
CE19	1	1	1	DD10050370	Ceramic 5pF $\pm$ 0.25pF
CE20	1	1	1	EA10701090	Elect 100 $\mu$ F 10V
CE21	1	1	1	EA10701090	Elect 100 $\mu$ F 10V
CE22	1	1	1	EE10505050	Elect 1 $\mu$ F 50V
CE23	1	1	1	EE10505050	Elect 1 $\mu$ F 50V
CE24	1	1	1	EE47503550	Elect 4.7 $\mu$ F 35V
CE25	1	1	1	EE47503550	Elect 4.7 $\mu$ F 35V
CE26	1	1	1	EA10703590	Elect 100 $\mu$ F 35V
<b>PE00-RESISTORS (All Resistors are <math>\pm</math>5% and <math>\frac{1}{4}</math>W)</b>					
RE01	1	1	1	RM01040200	Variable 100K $\Omega$ (A)
RE02	1	1	1	RK02040070	Variable 200K $\Omega$ (B)
RE04	1	1	1	GD05473140	47K $\Omega$
RE05	1	1	1	GD05184140	180K $\Omega$
RE06	1	1	1	GD05564140	560K $\Omega$
RE07	1	1	1	GD05564140	560K $\Omega$
RE08	1	1	1	GD05222140	2.2K $\Omega$
RE09	1	1	1	GD05222140	2.2K $\Omega$
RE10	1	1	1	GD05512140	5.1K $\Omega$
RE11	1	1	1	GD05512140	5.1K $\Omega$
RE12	1	1	1	GD05911140	910 $\Omega$
RE13	1	1	1	GD05911140	910 $\Omega$
RE14	1	1	1	GD05334140	330K $\Omega$
RE15	1	1	1	GD05334140	330K $\Omega$
RE16	1	1	1	GD05103140	10K $\Omega$
RE17	1	1	1	GD05103140	10K $\Omega$
RE18	1	1	1	GD05103140	10K $\Omega$
RE19	1	1	1	GD05103140	10K $\Omega$
RE20	1	1	1	GD05183140	18K $\Omega$
RE21	1	1	1	GD05183140	18K $\Omega$



- (U): for U.S.A.
- (C): for Canada
- (N): for Europe

REF. DESIG.	Q'TY			PART NO.	DESCRIPTION
	U	C	N		
RE22	1	1	1	GD05561140	560Ω
RE23	1	1	1	GD05561140	560Ω
RE24	1	1	1	RM01040210	Variable 100KΩ (B)
RE25	1	1	1	RM01040210	Variable 100KΩ (B)
RE26	1	1	1	GD05222140	2.2KΩ
RE27	1	1	1	GD05222140	2.2KΩ
RE28	1	1	1	GD05123140	12KΩ
RE29	1	1	1	GD05683140	68KΩ
RE30	1	1	1	GD05564140	560KΩ
RE31	1	1	1	GD05564140	560KΩ
RE32	1	1	1	GD05621140	620Ω
RE33	1	1	1	GD05621140	620Ω
RE34	1	1	1	GD05512140	5.1KΩ
RE35	1	1	1	GD05512140	5.1KΩ
RE36	1	1	1	GD05472140	4.7KΩ
RE37	1	1	1	GD05472140	4.7KΩ
RE38	1	1	1	GD05104140	100KΩ
RE39	1	1	1	GD05104140	100KΩ
RE40	1	1	1	GD05221140	220Ω
RE41	1	1	1	GD05221140	220Ω
RE42	1	1	1	GG05221140	220Ω
<b>RE00-SEMICONDUCTORS</b>					
QE01	1	1	1	HT312221E0	Transistor 2SC1222 (E)
QE02	1	1	1	HT312221E0	Transistor 2SC1222 (E)
QE03	1	1	1	HT312221E0	Transistor 2SC1222 (E)
QE04	1	1	1	HT312221E0	Transistor 2SC1222 (E)
<b>PE00-MISCELLANEOUS</b>					
JE01	1	1	1	YU08120010	Jumper Lead (10P)
<b>PP01-FUSE CIRCUIT BOARD</b>					
PP01	1	1		YF22760020	P.W. Board, Fuse
				ZZ22761020	P.W. Board Assembly
<b>M1515, ONLY</b>					
PP01		1		YF22760030	P.W. Board, Fuse
		1		ZZ22768030	P.W. Board Assembly
<b>MR215, ONLY</b>					
PP01		1		YF22760032	P.W. Board, Fuse
		1		ZZ22768030	P.W. Board Assembly
<b>PP01-FUSE</b>					
FP01	1			FS10150900	Fuse 1.5A 125V
FP02	1			FS10150900	Fuse 1.5A 125V
FP03	1			FS10150900	Fuse 1.5A 125V
FP04	1			FS10150900	Fuse 1.5A 125V
FP01		1		FS10160800	Fuse 1.6AT 250V
FP02		1		FS10160800	Fuse 1.6AT 250V
FP03		1		FS10160800	Fuse 1.6AT 250V
FP04		1		FS10160800	Fuse 1.6AT 250V
<b>PP01-JACK</b>					
JP01					
JP08	8	8		YJ08000200	Jack, Fuse Holder
JP09	1	1		YP06001560	Plug

REF. DESIG.	Q'TY			PART NO.	DESCRIPTION
	U	C	N		
<b>PS00-SWITCH CIRCUIT BOARD</b>					
PS00	1	1	1	YK22760410	P.W. Board, Switch
	1	1		ZZ22760410	P.W. Board Assembly
			1	ZZ22768410	P.W. Board Assembly
<b>PS00-CAPACITORS</b>					
CS01	1	1	1	DD15561370	Ceramic 560pF ±5%
CS02	1	1	1	DD15561370	Ceramic 560pF ±5%
CS03	1	1	1	DF17683300	Film 0.068μF ±20%
CS04	1	1	1	DF17683300	Film 0.068μF ±20%
CS05	1	1		DF15222300	Film 0.0022μF ±5%
CS06	1	1		DF15222300	Film 0.0022μF ±5%
CS07			1	DF17104300	Film 0.1μF ±20%
CS08			1	DF17104300	Film 0.1μF ±20%
CS09			1	EE33405040	Elect 0.33μF 50V
CS10			1	EE33405040	Elect 0.33μF 50V
CS11	1	1		DF15472300	Film 0.0047μF ±5%
CS12	1	1		DF15472300	Film 0.0047μF ±5%
<b>PS00-RESISTORS</b> (All Resistors are ±5% and 1/4W)					
RS01	1	1	1	GD05332140	3.3KΩ
RS02	1	1	1	GD05332140	3.3KΩ
RS03	1	1	1	GD05473140	47KΩ
RS04	1	1	1	GD05473140	47KΩ
RS05	1	1	1	GD05562140	5.6KΩ
RS06	1	1	1	GD05562140	5.6KΩ
RS07	1	1		GD05103140	10KΩ
RS08	1	1		GD05103140	10KΩ
RS11	1	1		GD05432140	4.3KΩ
RS12	1	1		GD05432140	4.3KΩ
RS13			1	GD05393140	39KΩ
RS14			1	GD05393140	39KΩ
RS15	1	1		GD05221140	220Ω
RS16	1	1		GD05332140	3.3KΩ
RS17	1	1		GD05332140	3.3KΩ
<b>PS00-SWITCH</b>					
SS01	1	1	1	SP02050040	Push Switch
<b>PY00-LED CIRCUIT BOARD</b>					
PY00	1	1	1	YK22761220	P.W. Board, LED
	1	1	1	ZZ22761220	P.W. Board Assembly
QY01	1	1	1	HI0009020	L.E.D LN26RP Stereo Ind.
<b>M1515 (U)(C)(N)</b> <b>MR215 (N), ONLY</b>					

(W01-99)	Assembly and Wiring
(T01-99)	Adjustment
(X01-00)	Correction



**7. TECHNICAL SPECIFICATIONS  
[FOR U.S.A. CANADIAN MODELS ONLY]**

**AMPLIFIER SECTION:**

Minimum Continuous Watts per Channel, both Channels Driven	
into 8 ohms . . . . .	15 W
into 4 ohms . . . . .	17 W
Power Band	
at 8 ohms . . . . .	20 Hz - 20 kHz
at 4 ohms . . . . .	20 Hz - 20 kHz
Total Harmonic Distortion	
at 8 ohms . . . . .	0.08%
at 4 ohms . . . . .	0.15%
I.M. Distortion	
(I.H.F. method, 20 Hz and 7 kHz mixed 4:1 at rated power output)	
at 8 ohms . . . . .	0.08%
Damping Factor at 20 Hz . . . . .	25

**PREAMPLIFIER SECTION:**

Phono	
Input Overload at 1 kHz . . . . .	100 mV
Equivalent Input Noise, "A" weighted . . . . .	3 $\mu$ V
Input Sensitivity (Input Impedance, 47 kohms) . . . . .	2.8 mV
Frequency Response (RIAA, 20 Hz to 20 kHz) . . . . .	$\pm$ 0.75 dB
High Level Inputs (Aux and Tape)	
Input Sensitivity . . . . .	180 mV
Input Impedance . . . . .	20 kohms

**AM/FM TUNER SECTION:**

Sensitivity	
IHF Usable (Mono) . . . . .	10.8 dBf (1.9 $\mu$ V)
IHF 50 dB Quieting	
Mono . . . . .	14.5 dBf (2.9 $\mu$ V)
Stereo . . . . .	37.7 dBf (42 $\mu$ V)
Distortion, Mono and (Stereo) at 65 dBf	
1000 Hz . . . . .	0.2% (0.35%)
Hum and Noise at 65 dBf (1000 $\mu$ V)	
Mono . . . . .	-70 dB
Capture Ratio at 65 dBf (1000 $\mu$ V) . . . . .	1.0 dB
Alternate Channel Selectivity . . . . .	60 dB
Spurious Response Rejection . . . . .	90 dB
Image Response Rejection . . . . .	50 dB
IF Rejection (Balanced) . . . . .	90 dB
AM Suppression . . . . .	50 dB
Stereo Separation 1000 Hz . . . . .	42 dB
AM Usable Sensitivity (IHF) . . . . .	20 $\mu$ V
AM Distortion (THD) at 30% Modulation . . . . .	1.0%
AM Signal-to-Noise Ratio . . . . .	50 dB

**GENERAL:**

Power Requirements . . . . .	120 V AC, 60 Hz
Power Consumption at rated output, both channels operating . . . . .	98 W
Idling Power (Volume Control at zero) . . . . .	28 W
Dimensions	
Panel Width . . . . .	17-1/4" (440 mm)
Panel Height . . . . .	5-3/8" (137 mm)
Depth . . . . .	14-1/16" (357 mm)



Weight

Unit alone . . . . .	9 kg (19.8 lbs.)
Packed for shipment . . . . .	10.5 kg (23.1 lbs.)



**[FOR EUROPEAN MODEL ONLY]**

**AUDIO SECTION:**

POWER OUTPUT, DIN, 4 OHM, PER CHANNEL .....	31 W
POWER OUTPUT, FTC AMERICAN STANDARDS, 4 OHM, PER CHANNEL .....	18 W
TOTAL HARMONIC DISTORTION AT RATED POWER OUTPUT .....	0.2%
<b>I.M. DISTORTION AT RATED POWER OUTPUT</b>	
(250 Hz AND 8 kHz MIXED, AMPLITUDE RATIO 4:1) .....	0.2%
POWER BANDWIDTH .....	10 Hz ~ 40 kHz
POWER OUTPUT, DIN, 8 OHM, PER CHANNEL .....	26 W
POWER OUTPUT, FTC AMERICAN STANDARDS, 8 OHM, PER CHANNEL .....	21 W
TOTAL HARMONIC DISTORTION AT RATED POWER OUTPUT .....	0.1%
<b>I.M. DISTORTION AT RATED POWER OUTPUT</b>	
(250 Hz AND 8 kHz MIXED, AMPLITUDE RATIO 4:1) .....	0.1%
POWER BANDWIDTH .....	10 Hz ~ 40 kHz
	(40 Hz)    (1 kHz)    (12.5 kHz)
<b>DAMPING FACTOR 8 OHM</b> .....	44            45            42
<b>Frequency Response</b>	
Phono (RIAA) .....	±1.0 dB
Aux (±1 dB) .....	18 Hz ~ 30 kHz
<b>Signal-to-Noise Ratio</b>	
Phono .....	72 dB
Aux .....	80 dB
<b>Input Terminals</b>	
Phono: Input Impedance .....	47 kohms
Input Sensitivity .....	2.8 mV
Overload Margin .....	30 dB
Aux: Input Impedance .....	20 kohms
Input Sensitivity .....	180 mV
Overload Margin .....	35 dB
Phono Equivalent Input Noise .....	1.2 µV
Phono Dynamic Range (Ratio of input overload to equivalent input noise) .....	100 dB
<b>Channel Balance (0 to -40 dB/40 Hz ~ 16 kHz)</b>	
Phono .....	2.5 dB
Aux .....	2.0 dB
<b>Interchannel Crosstalk</b>	
Phono 1 kHz .....	35 dB
Aux 1 kHz .....	43 dB
Tape 1 kHz .....	55 dB
<b>Intersource Crosstalk (Worst Point)</b>	
1 kHz .....	44 dB
<b>Output Voltage, 1 kHz</b>	
Tape Out .....	500 mV
<b>Output Impedance, 1 kHz</b>	
Tape Out .....	200 ohms
Headphone Jack Load Impedance .....	8 ohms

**FM TUNER SECTION:**

Frequency Range .....	87.4 ~ 109 MHz
<b>Usable Sensitivity 40 kHz Deviation, 98 MHz</b>	
Mono, S/N 26 dB .....	1.7 µV
Stereo, S/N 46 dB .....	48 µV
Alternate Channel Selectivity, 98 MHz ±300 kHz .....	36 dB
Image Response Rejection, 98 MHz .....	50 dB
IF Rejection, 98 MHz .....	100 dB
Spurious Response Rejection, 98 MHz .....	110 dB
AM Suppression, 98 MHz .....	52 dB



Signal-to-Noise Ratio, 98 MHz	
Unweighted: Mono	62 dB
Stereo	55 dB
Weighted: Mono	66 dB
Stereo	60 dB
Pilot Signal & Subcarrier Rejection	
19 kHz	58 dB
38 kHz	58 dB
Total Harmonic Distortion, 98 MHz	
Mono	0.1%
Stereo	0.2%
Frequency Response	
30 Hz ~ 15 kHz	+0.5 dB, -2.0 dB
Separation	
Stereo	45 dB
Channel Balance	0.5 dB
Output Voltage, 1 kHz	600 $\mu$ V
Output Impedance, 1 kHz	4.4 kohms
Acceptable Load Impedance, 1 kHz	47 kohms
Antenna Terminals	
Balanced	300 ohms
Unbalanced	75 ohms

#### AM TUNER SECTION:

Frequency Range	515 ~ 1650 kHz
Usable Sensitivity (26 dB S/N 30% Mod., 1 MHz)	30 $\mu$ V
Selectivity, 1 MHz $\pm$ 9 kHz	20 dB
Image Rejection, 1 MHz	41 dB
IF Rejection, 1 MHz	55 dB
Spurious Response Rejection, 1 MHz	38 dB
Signal-to-Noise Ratio, 1 MHz	43 dB
Frequency Response, 1 MHz $\pm$ 3 dB	40 Hz ~ 2.2 kHz
Total Harmonic Distortion, 1 MHz	1.0%

#### GENERAL:

Power Requirements	220 V AC, 50 Hz
(N version is featuring an external voltage selector for use on 110/120/240 V. Other versions can be converted by a qualified technician to operate on 110/120/240 V.)	
Power Consumption at Rated Output, Both Channels Operating	98 W
Idling Power	25 W
Semiconductor Complement	
Integrated Circuits	5
Transistors	29
Diodes	19
Field Effect Transistor	1
Dimensions	
Panel Width	17-3/8" (440 mm)
Panel Height	5-3/8" (137 mm)
Depth	14-1/8" (358 mm)
Weight	
Unit alone	19.8 lbs (9.0 kg)
Packed for shipment	23.1 lbs (10.5 kg)

NOTE





**marantz.**

**MARANTZ CO., INC. · P.O. BOX 577 · CHATSWORTH, CALIFORNIA · 91311**



A WHOLLY-OWNED SUBSIDIARY OF SUPERSCOPE INC., CHATSWORTH, CALIFORNIA · 91311