

TANDBERG

Series 6000X

SERVICE MANUAL

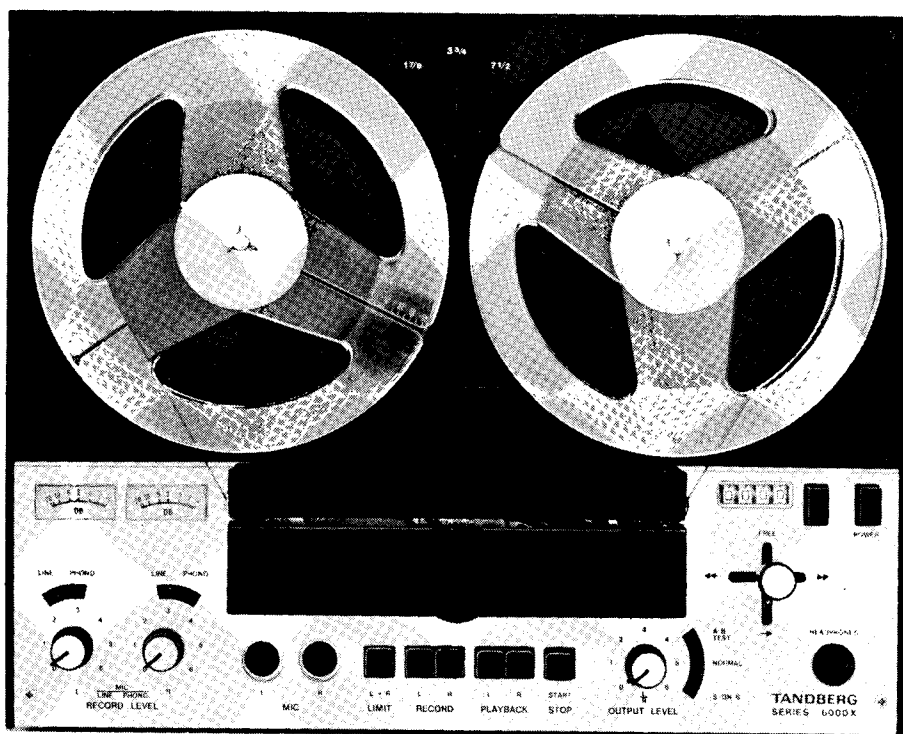

ELECTRONIC SERVICE CENTER
401 W. 11th Street, N.W.
8622 HILLENWAY DRIVE
JACKSONVILLE, FLA. 32210
313-751-1111

TANDBERGS RADIOFABRIKK A/S

CONTENTS

<ul style="list-style-type: none"> 1.0 Mechanical Adjustments 2 1.1 Clutches 2 <ul style="list-style-type: none"> 1.1.1 Take-up Turntable 2 1.1.2 Supply Turntable 3 1.2 Brakes 4 1.3 Pressure Pad Adjustment 4 1.4 End Stop Mechanism 5 <ul style="list-style-type: none"> 1.4.1 Tape Feeler Tension 5 1.4.2 Adjustment of Tape Feeler 5 2.0 Alignment 6 2.1 Demagnetizing 6 2.2 Bias- and Erase Circuits 6 <ul style="list-style-type: none"> 2.2.1 Oscillator Frequency 6 2.2.2 Erase Voltage 6 2.2.3 Bias Current 6 3.0 Tape Path 6 3.1 Visual Check 6 3.2 Mechanical Adjustment of Tape Path 6 4.0 Head Alignment with Tandberg Test Tapes Model 6041X 7 4.1 Playback Head 7 <ul style="list-style-type: none"> 4.1.1 Height Adjustment 7 4.1.2 Azimuth Adjustment 7 4.2 Record Head 7 <ul style="list-style-type: none"> 4.2.1 Height Adjustment by Visual Inspection 7 4.2.2 Height Adjustment by Track Measurement 7 4.3 Bias Head 7 <ul style="list-style-type: none"> 4.3.1 Vertical Adjustment 7 4.3.2 Height Adjustment 7 4.3.3 Horizontal Adjustment 7 4.4 Erase Head 7 <ul style="list-style-type: none"> 4.4.1 Height Adjustment 7 4.4.2 Azimuth Adjustment 7 4.5 Model 6021X 7 5.0 Head Alignment Without Tandberg Test Tapes, Model 6041X 8 5.1 Playback Head 8 <ul style="list-style-type: none"> 5.1.1 Height Alignment 8 5.1.2 Azimuth Alignment 8 5.2 Record Head 8 5.3 Bias Head 8 5.4 Erase Head 8 <ul style="list-style-type: none"> 5.4.1 Height Adjustment 8 5.4.2 Azimuth Adjustment 8 5.5 Model 6021X 8 6.0 Track Control 8 6.1 Model 6041X 8 <ul style="list-style-type: none"> 6.1.1 Record Head 8 6.1.2 Erase Head 8 6.1.3 Playback Head 8 6.2 Model 6021X 9 <ul style="list-style-type: none"> 6.2.1 Erase Head 9 6.2.2 Record Head 9 6.2.3 Playback Head 9 	<ul style="list-style-type: none"> 7.0 Adjustment and Control of the Amplifiers 9 <ul style="list-style-type: none"> 7.1.1 Playback Level Adjustment 9 7.1.2 Adjustment of Bias Current 9 7.1.3 Record Level Adjustment 9 7.1.4 Record/Playback Curves 9 7.1.5 Indicator Adjustment in Record Mode 9 7.1.6 Distortion 9 7.1.7 Indicator Adjustment in Playback and Amplifier Modes 9 7.1.8 Control of the Playback Amplifier 9 7.2 Tape Speed Control 10 <ul style="list-style-type: none"> 7.2.1 Using Frequency Meter or Counter 10 7.2.2 Using Transformer and Vacuum Tube Voltmeter 10 7.2.3 Using Tape of Known Length 10 8.0 Adjustment of the Amplifiers, without Tandberg Test Tapes 10 <ul style="list-style-type: none"> 8.1 Playback and Record Level Adjustment 10 8.2 Record/Playback Curves 10 8.3 Readjustment of Record Levels and Indicators 10 8.4 Distortion 10 8.5 Control of Playback and Record Amplifiers 11 <ul style="list-style-type: none"> 8.5.1 Playback Amplifier 11 8.5.2 Record Amplifier 11 8.6 Pick-up Amplifier Curve 11 8.7 Limiter 12 <ul style="list-style-type: none"> 8.7.1 Adjustment of Limiting Threshold 12 8.7.2 Adjustment of Release Time 12 9.0 Modifications 13 <ul style="list-style-type: none"> 9.1 Modification from 230/115V 50 Hz to 230/115V 60 Hz operation 12 9.2 Modification from Four-Track to Two-Track Version 13 9.3 Important Electrical Modifications Introduced in Series 6000X 13 10.0 Lubrication 13 11.0 Illustrations with Reference Part Numbers 14 12.0 Spare Parts List for Tandberg Tape Recorder 6000X 17 <ul style="list-style-type: none"> 12.1 Mechanical Parts 17 12.2 Screws, Washers, Nuts and Circlips 21 12.3 Electrical Components 21 <ul style="list-style-type: none"> 12.3.1 Transistors 21 12.3.2 Diodes 22 12.3.3 Rectifier 22 12.3.4 Trimming Capacitor 22 12.3.5 Potentiometers 22 12.3.6 Heads 22 12.3.7 Transformers 22 13.0 Transistor and Diode Identification 23 14.0 Block Diagram Series 6000X 23 15.0 Printed Wiring Boards and Wiring Diagram 24
--	--

1.0 MECHANICAL ADJUSTMENT

1.1 Clutches

1.1.1 Take-up Turntable

Normal Forward drive

Set the operating lever to normal forward drive position with the motor running. Ensure that the clearance between the polyurethane friction pads under the turntable and friction disc 991009 lays between 0,5—0,9 mm (0.02"—0.035"). If necessary, adjust screw A as shown in fig. 1.1.

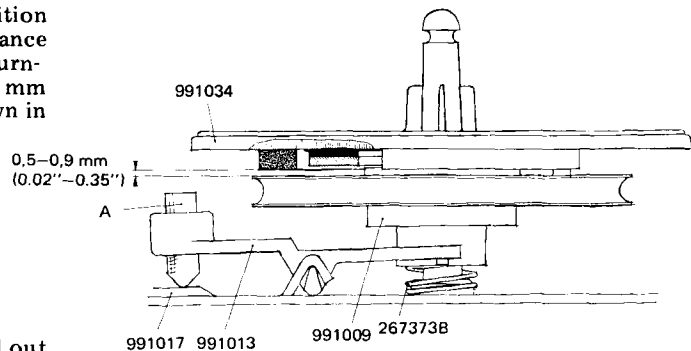

Fig. 1.1

Control of Winding Torque

Note: All controls and measurements must be carried out with the tape recorder placed in horizontal position and with empty reels only.

The control is accomplished as shown in fig. 1.2, which presents two optional modes of control.

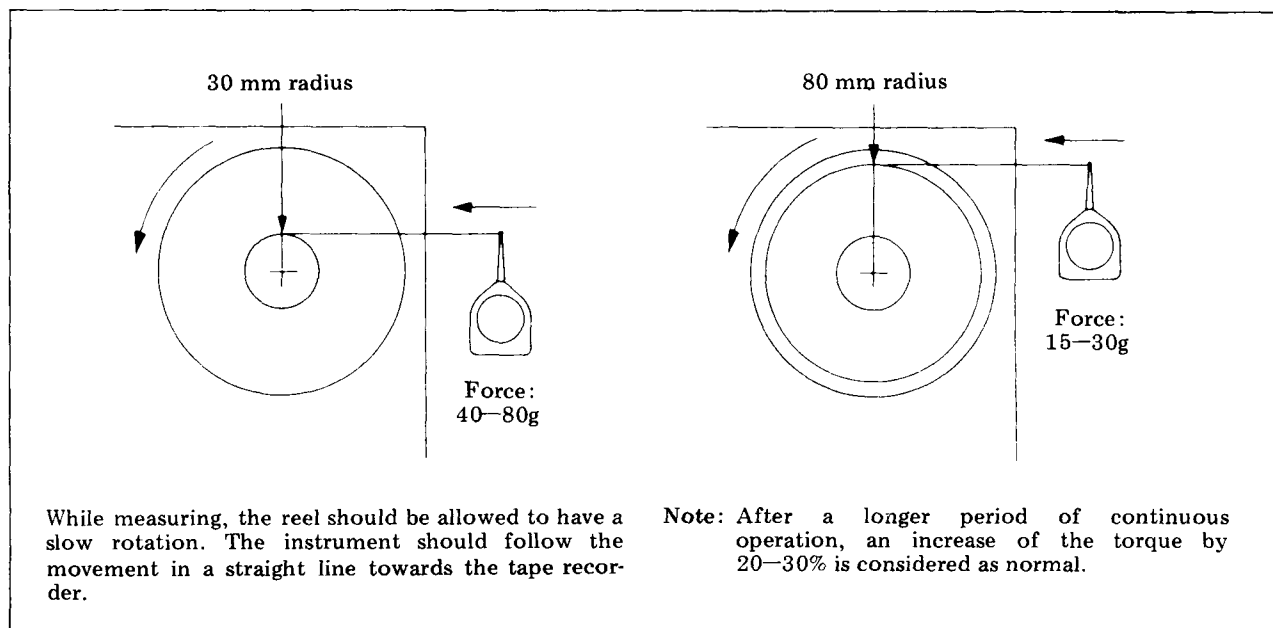

Fig. 1.2 Control of winding force. Normal forward drive mode.

Fast Forward Winding

Control of Fast Winding Torque

Set the operating lever to fast forward winding position. The control is accomplished as shown in fig. 1.3, which presents two optional modes of control.

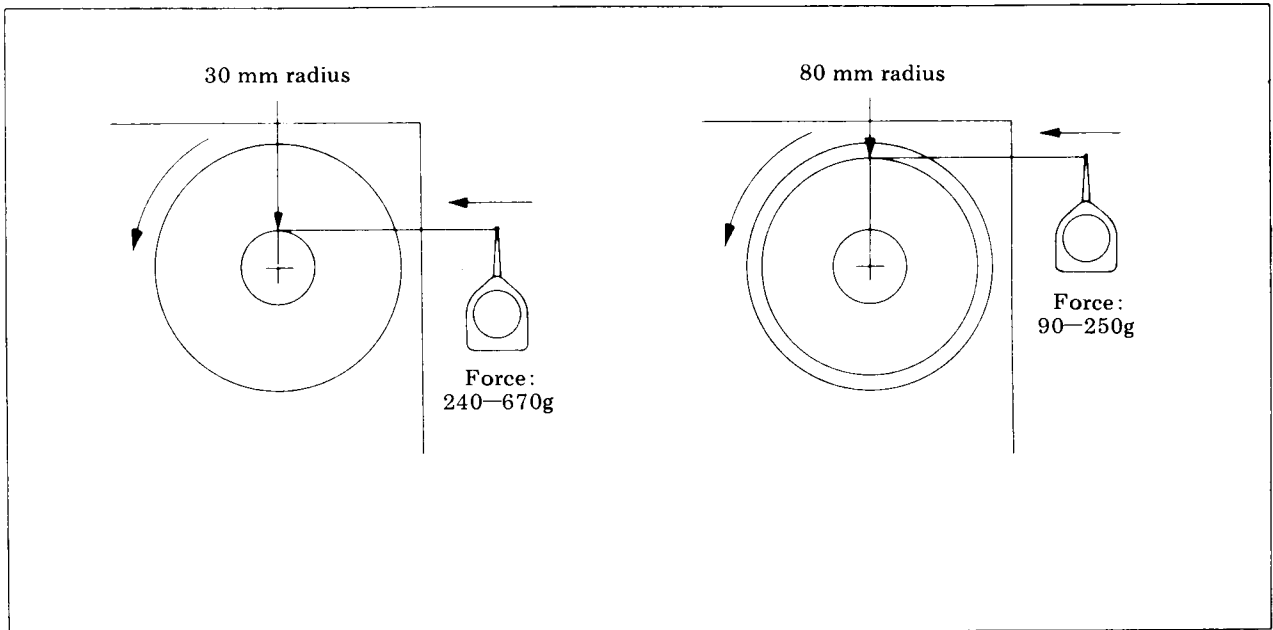

Fig. 1.3 Control of fast winding torque. Fast forward winding mode.

If the torque deviates from the specifications in the figure, check and, if necessary, alter the pressure of spring 267373B.

Ensure that there is a clearance between the studs on friction disc 991010 and lever 991013. See fig. 1.4.

1.1.2 Supply Turntable

Control of Tape Tightening Tension

Set the operating lever to normal forward drive position. The control is accomplished as shown in fig. 1.5, which presents two optional modes of control.

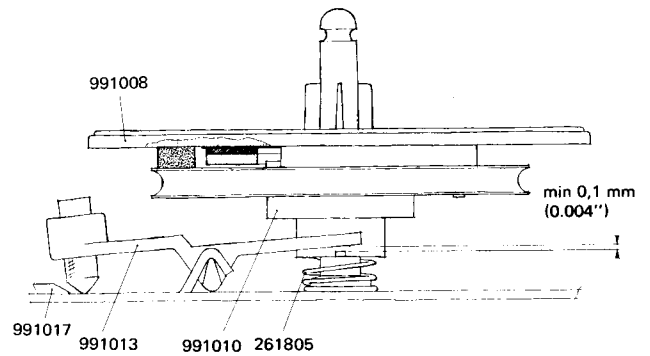
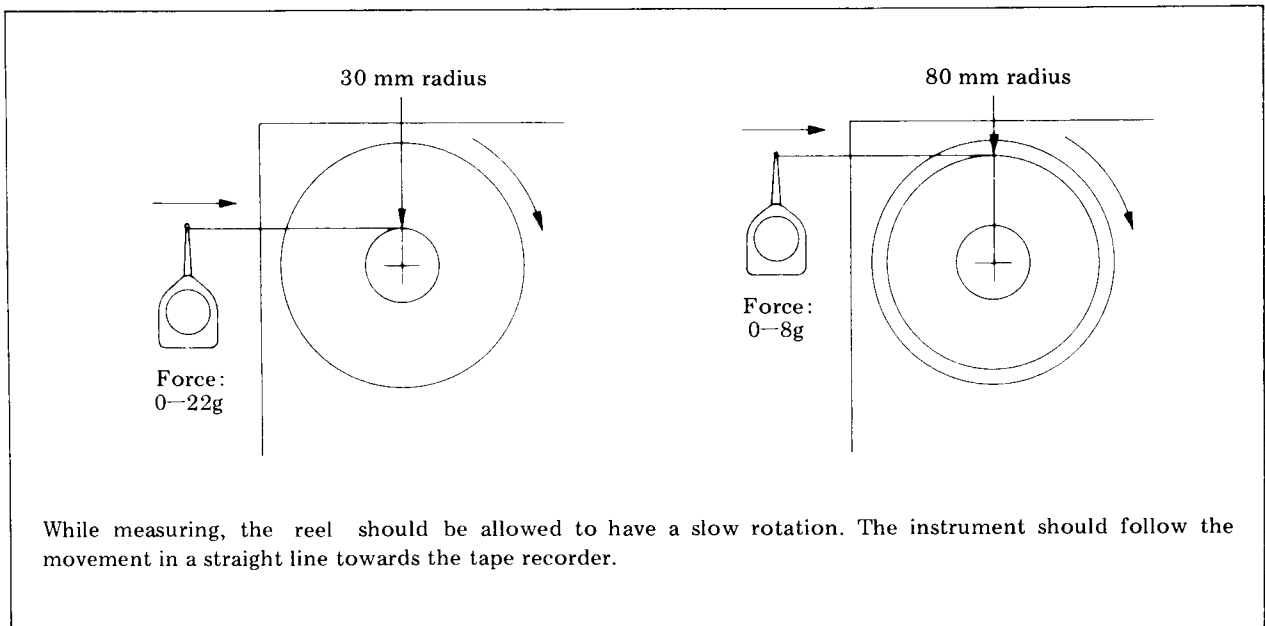

Fig. 1.4



While measuring, the reel should be allowed to have a slow rotation. The instrument should follow the movement in a straight line towards the tape recorder.

Fig. 1.5 Control of tape tightening tension. Normal forward drive mode.

Fast Reverse Winding Control of Fast Reverse Winding Torque

Set the operating lever to fast reverse winding position. The control is accomplished as shown in fig. 1.6, which presents two optional modes of control.

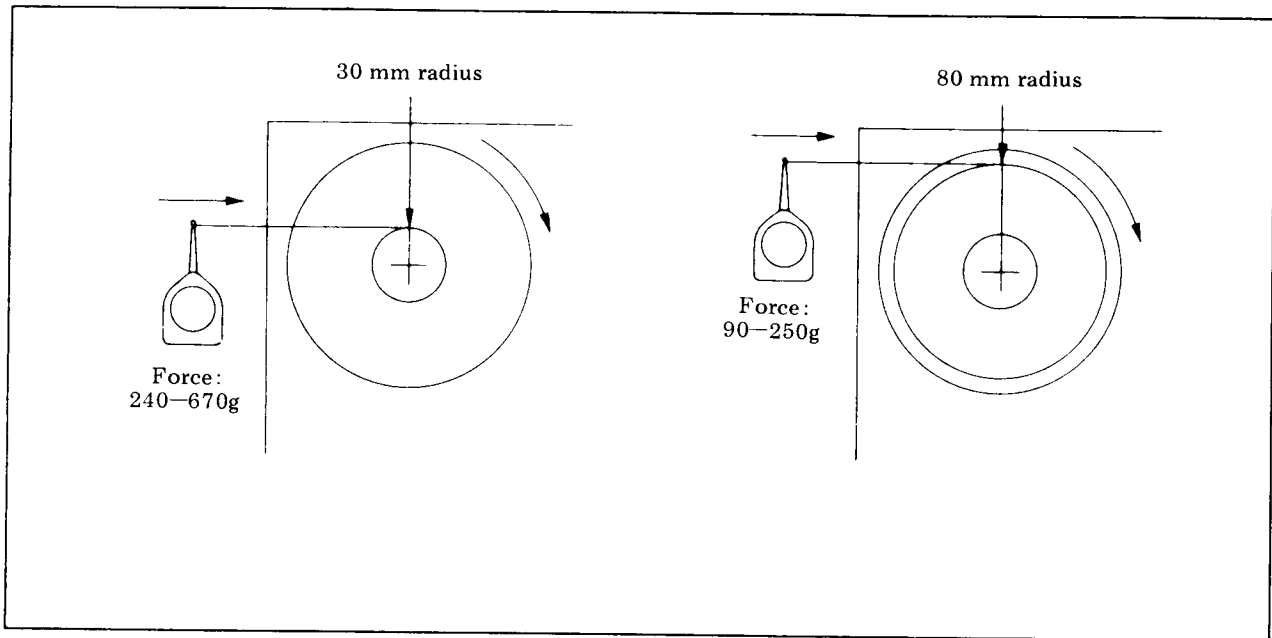

Fig. 1.6 Control of fast reverse winding torque. Fast reverse winding mode

If the torque deviates from the specifications in the figure, check and, if necessary, alter the pressure of spring 261805. See fig. 1.7.

The difference between Fast Winding Torque and Fast reverse Winding Torque should be less than 130 g (force measured at 30 mm radius), or 50 g (measured at 80 mm radius). If necessary, alter the pressure of spring 261805 (fig. 1.7), or spring 267373B (fig. 1.1).

1.2 Brakes

See fig. 1.8.

Set the operating lever to normal forward drive position. Check that the clearance between the brake pad and the turntable is approx. 1 mm (0.04"). If necessary, adjust screw D.

Set the operating lever to fast forward winding or fast reverse winding respectively. Ensure that the clearance between screw C and the bottom of the hinged delrin parts on operating arm 991017 lays between 0,5–1 mm (0.02"–0.04"). If necessary, adjust screw C.

The adjustment procedure is equal for both turntables.

1.3 Pressure Pad Adjustment

Set the operating lever to neutral position. The clearance between the pressure pad 990325 and the tape rest 254844 should be approx. 6,5 mm (1/4") as shown in fig. 1.9. If necessary, adjust the clearance by bending the arm 254025 with a pair of pliers. See fig. 1.10.

Set the operating lever to normal forward drive position. The pressure of the pad against the tape rest should be 80 g (2.8 oz) \pm 10 %, measured on the end of the pressure pad arm 254025. See fig. 1.11. If necessary, adjust the pressure by bending the spring 268062 with a pair of pliers. See fig. 1.12.

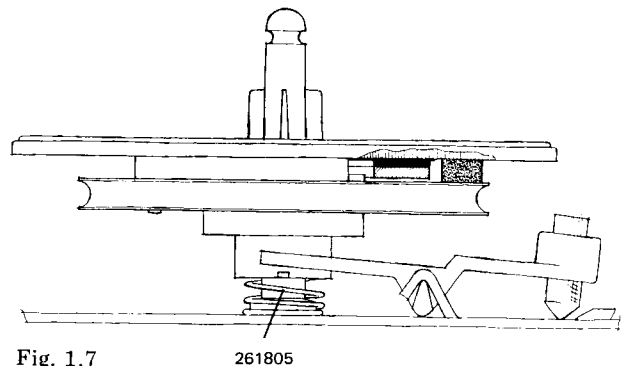

Fig. 1.7 261805

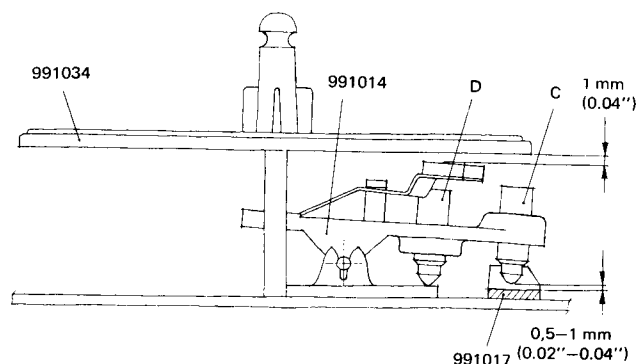

Fig. 1.8

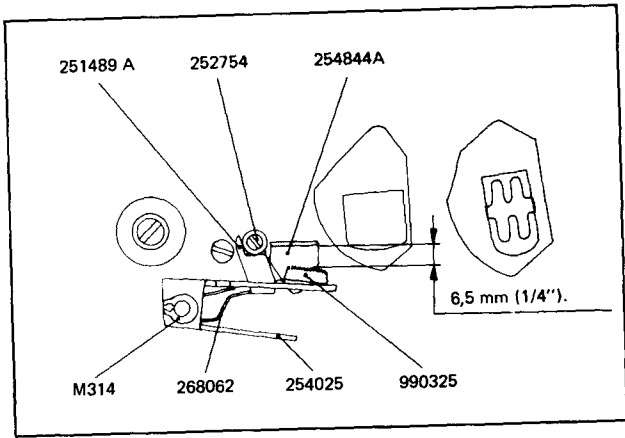

Fig. 1.9

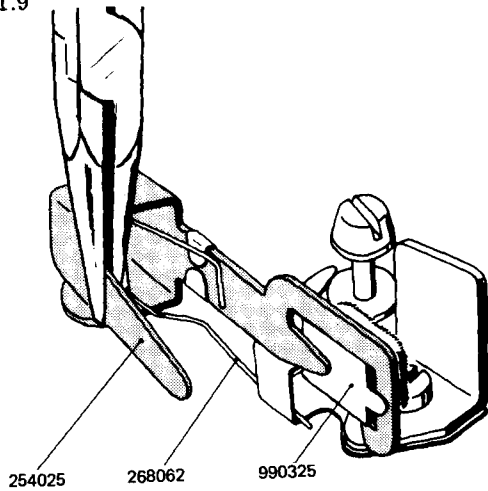

Fig. 1.10

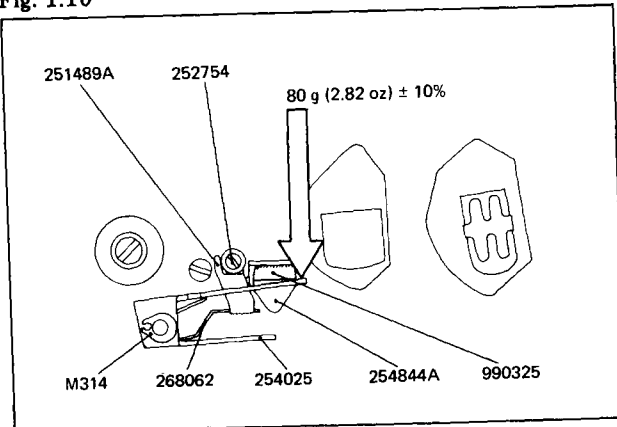

Fig. 1.11

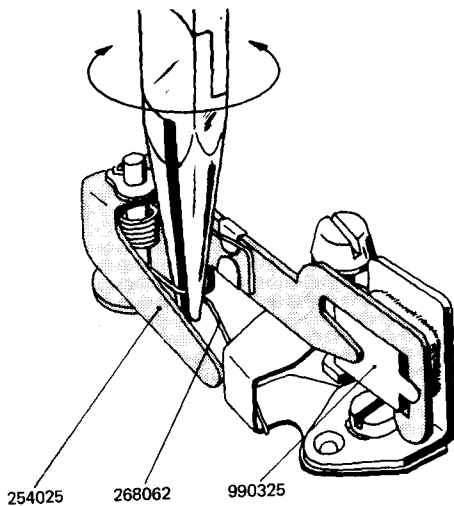

Fig. 1.12

1.4 End Stop Mechanism

1.4.1 Tape Feeler Tension

The feeler tension against the tape should lay between 8 and 10 g (0.28–0.35 oz) in drive and winding modes. Adjustment of the tension is accomplished by tightening or slackening the spring 243990. See fig. 1.14.

1.4.2 Adjustment of Tape Feeler

See fig. 1.13 and 1.14.

Set the operating lever in normal forward drive position, or forward or reverse winding. The mains switch is set to ON. No tape should be inserted. The tape feeler will therefore rest in the position where the motor is switched off. Push the feeler slowly through the guide post. When the rear side of the feeler is min. 0,5 mm (0.02'') from the polished contact surface of the guide post the microswitch should close and start the motor. If not, loosen screw F, and move the microswitch slowly until the motor starts when the tape feeler is in the position specified above. Then tighten the screw. When the tape feeler is released, the microswitch should open, and stop the motor when the spacing between the tape feeler and the arm 244694A is minimum (0,5 mm (0.02'')).

See fig. 1.14.

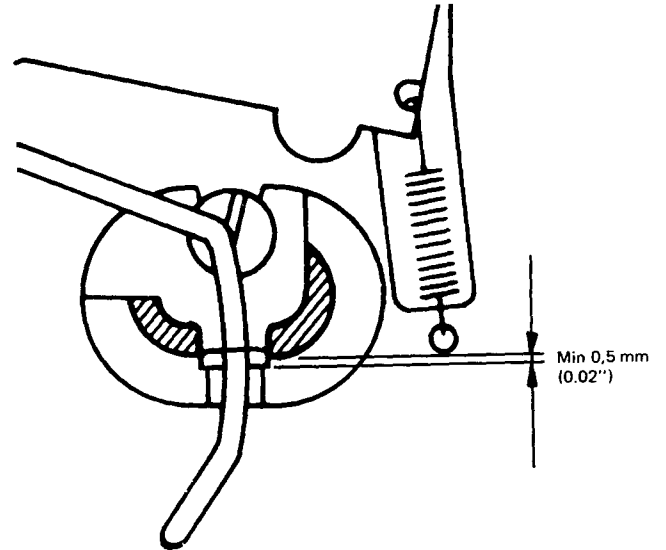

Fig. 1.13

Adjustment distance minimum 0,5 mm (0.02'')

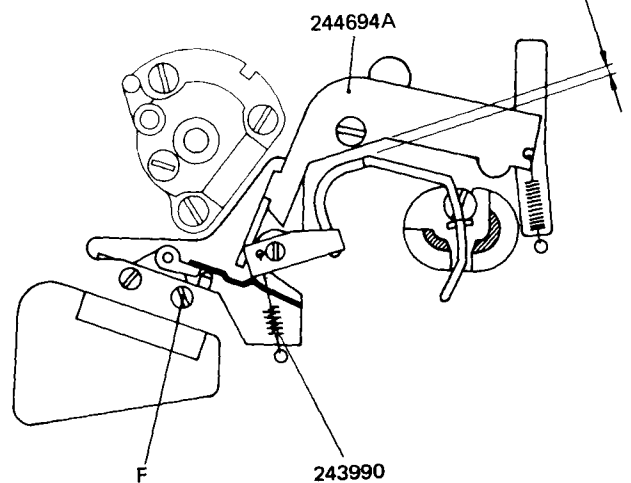

Fig. 1.14

2.0 ALIGNMENT

It is important that the contact between the tape and the heads on the tape recorder is good. To obtain optimum results on new tapes, the tape should be run through the tape recorder approx. 5 times at normal speed to have the tape polished before measuring the frequency response and the signal-to-noise ratio.

2.1 Demagnetizing

Demagnetize the heads and adjacent parts before aligning the heads.

2.2 Bias- and Erase Circuits

2.2.1 Oscillator Frequency

Connect a calibrated long wave receiver (tuned to 256.5 kHz), frequency meter or frequency counter to the oscillator by means of a pick-up loop placed around the erase head. Adjust the oscillator frequency to 85.5 kHz by means of C404.

2.2.2 Erase Voltage

Set the tape recorder for stereo recording and connect a VTVM to upper half of the erase head by means of a low-capacitance probe. The voltage should be 80–120V. Then check that the same voltage appears across lower head-half.

Set the tape recorder for recording on channel L and check the voltage across upper half of the erase head. The deviation from the voltage measured in stereo recording should not exceed 10V. Proceed similarly for recording on channel R.

2.2.3 Bias Current

Set the tape recorder for stereo recording and measure the voltage across upper half of the bias head by means of a VTVM. Adjust the voltage to 22V by means of R407. Check the voltage across lower head-half and adjust to 22V by means of R410. Demagnetize heads and tape path.

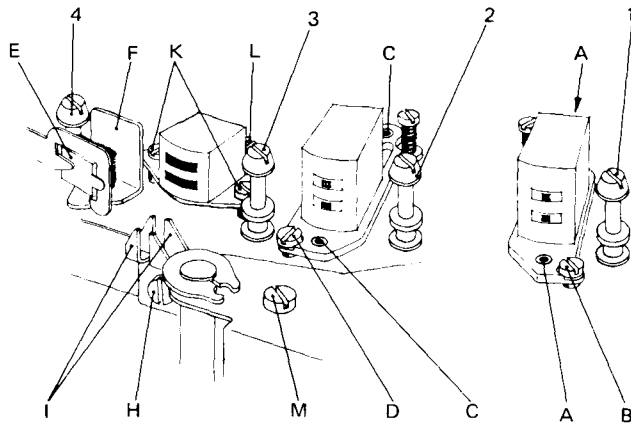

Fig. 3.1 Tape path adjustment screws

3.2 Mechanical adjustment of tape path

Prior to the electrical adjustment of the heads, it is essential to make the tape run without sideways movement through the path.

Set the operating lever to neutral position. Unscrew the screw holding latch 215563 to allow the latch to settle in the position determined by spring 234478. Then tighten the screw. The spring pressure will now be equal against the upper and lower points of pressure roller pivot 247941.

Put a tape free from damages on the recorder in normal way and set the operating lever to normal forward drive position. Adjust the azimuth position of pressure roller 990334 with a screw driver as shown in fig. 3.2, until the tape is running evenly through the rest of the tape path, slightly touching one of the flanges of the tape post 1 located adjacent to the capstan.

Align guide post 2, 3, and 4 similarly. If necessary, adjust pressure roller spring 234478 to make the tape run perfectly.

3.0 TAPE PATH

3.1 Visual Check

Load the recorder with a tape, and move the operating lever slowly to the normal forward drive position. Check that the bias head neither touches the height adjustment screws (C) on the record head base plate, nor presses the tape against the record head. Also check that the bias head is parallel to the record head.

Operate the start/stop button, and check that the tape runs within the rims of the pressure wheel rubber without flickering on neither side of the pressure wheel. Check that height positioning of the guide posts is correct. It can be tolerated that the tape touches the flanges of the guide posts when the recorder is in normal forward drive, or as the drive mechanism is engaged. The tape must, however, by no means bulge at the flanges.

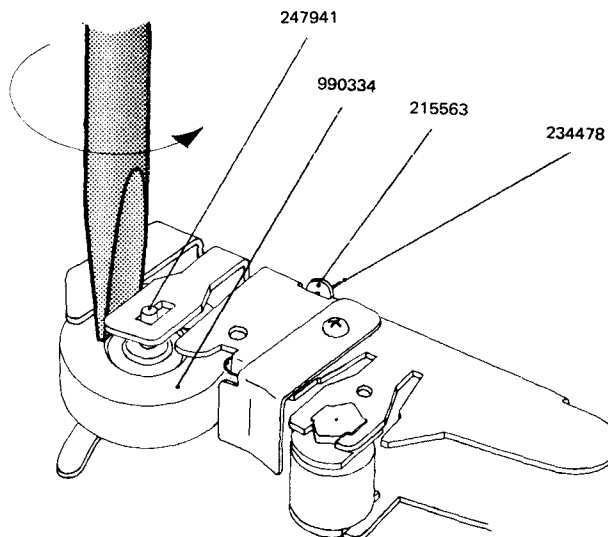

Fig. 3.2 Azimuth adjustment of pressure roller

4.0 HEAD ALIGNMENT WITH TANDBERG TEST TAPES, MODEL 6041X

4.1 Playback Head

Set the recorder for stereo playback and connect a VTVM to each one of the phono outputs.

4.1.1 Height Adjustment

Play Tandberg test tape No. 1. This is a full track prerecorded tape with 1.000 Hz recorded at 7 1/2 ips, and with the area corresponding to track 3 reduced by approx. 30 dB. Adjust the height of the playback head by means of the screws (A) until minimum output is obtained from track 3 (channel R), while endeavouring to maintain the headfront parallel to the tape.

4.1.2 Azimuth Adjustment

Play Tandberg test tape No. 2. This is a full track prerecorded tape with 10 000 or 15 000 Hz recorded at 7 1/2 ips. Adjust the azimuth position of the playback head by means of the screw (B), until maximum indication on the VTVM is obtained.

4.2 Record Head

4.2.1 Height Adjustment by Visual Inspection

Insert a new tape, and start the recorder in normal forward drive. Check visually that the tape appears to run parallel with the upper track of the record head, with a play of approx. 0,1 mm (4 mils). If necessary, adjust the height with screws (C) fig. 3.1, while endeavouring to maintain the headfront parallel to the tape.

4.2.2 Height Adjustment by Track Measurement

Record in stereo, well above normal level, first in one direction, then in the opposite. Cut off a length of tape and dip it into a solution of fine grained iron oxide powder and alcohol (Magna See). The tracks will then be visible as four dark stripes with spacings in lighter shade. Fig. 6.1 shows the correct pattern on the tape and the patterns obtained when the head is positioned either too high or too low.

Adjust as above and perform a new track measurement.

4.2.3 Azimuth Adjustment

Load a new tape into the tape recorder and record at tape speed 7 1/2 ips, a 15 000 Hz signal in stereo. Depress both playback buttons and turn both playback volume potentiometers to maximum. Adjust both Line Record Level knobs for approx. 150 mV at the outputs. Adjust the record head azimuth screw for maximum output from both channels simultaneously or best compromise.

4.3 Bias Head

4.3.1 Vertical Adjustment

Move the operating lever slowly to the normal forward drive position and check that the head fronts of bias- and record heads are parallel. If necessary, bend the arm of the bias head as required.

4.3.2 Height Adjustment

Set the tape recorder in record mode, and unscrew the locking screw (H) fig. 3.1, about 1/2 turn. Connect a VTVM across each one of the record head halves. Move the bias head up or down by means of adjustment screw M for the highest possible reading on the voltmeter. Check that the tape runs freely in the groove in front of the bias head and that there is sufficient clearance between the bias head and the mounting plate for the record head. The height position of the bias head is not critical, and if the clearance between the bias head and the mounting plate for the record head is insufficient, raise the bias head slightly.

4.3.3 Horizontal Adjustment

Connect a VTVM across each one of the record headhalves, and set the tape recorder for stereo recording. Insert a screwdriver in groove I, ref. fig. 3.1, and pull the bias head to the right.

Then pull the bias head carefully by means of the screwdriver towards the left hand side.

Induced voltage (bias) in recording head increases to a maximum. Continue pulling the head towards left side until the bias is reduced by 10–15 % below maximum. When the position has been found, thighten the screw (H) while maintaining correct horizontal position of the head. Then recheck the output voltage. If a noticeable change has occurred, the horizontal procedure has to be repeated.

4.4 Erase Head

4.4.1 Height Adjustment

By visual inspection, check that approx. 0,25 mm (10 mils) of the upper half of the erase head is visible above the tape. Insert Tandberg test tape No. 9 and record a 400 Hz signal at 7 1/2 ips well above normal level on channel R (track 3). Dip the tape in a solution of fine grained iron oxide powder and alcohol (Magna See solution). Check that the recorded track is positioned in centre of the erased track. Make sure that no parts of the adjacent tracks are erased, see fig. 6.2. If necessary, adjust the height of the erase head by means of the screws (K) and (L) ref. fig. 3.1, and repeat the above check.

4.4.2 Azimuth Adjustment

Check that the head front of the erase head is perpendicular to the mounting plate. If necessary, adjust azimuth position by means of the screws (K) ref. fig. 3.1. This adjustment is not critical.

4.5 Model 6021X

The alignments specified in para. 4.0 are valid for the model 6021X with the exception of paragraph 4.1.1, which is superseded by 5.1.1 and paragraph 4.2.1, which is superseded by 6.2.2.

5.0 HEAD ALIGNMENT WITHOUT TANDBERG TEST TAPES, MODEL 6041X

5.1 Playback Head

5.1.1 Height Alignment

The height of the playback head is aligned by the height adjustment screws (A), ref. fig. 3.1. The upper edge of the tape shall run flush with the upper part of the head lamination for channel L.

5.1.2 Azimuth Alignment

Play back a standard azimuth alignment tape with a VTVM connected to each output. Adjust the position of the playback head by the azimuth adjustment screw (B) ref. fig. 3.1, until maximum reading is obtained on the output meters.

5.2 Record Head

Follow the instructions given under paragraph 4.2.

5.3 Bias Head

Follow the instructions given under paragraph 4.3

5.4 Erase Head

5.4.1 Height Adjustment

The height of the erase head is aligned by the height adjustment screws (K and L) ref. fig. 3.1. Approx. 0,25 mm (10 mils) of the ferrite core for the upper track of the erase head should be visible above the tape.

5.4.2 Azimuth Adjustment

Align the azimuth position of the erase head by the azimuth adjustment screws (K). The erase head should be parallel with the mounting plate for the heads. The azimuth position of the erase head is not critical.

5.5 Model 6021X

The alignments specified in paragraph 5.0 are valid for model 6021X with the exception of paragraph 5.2 which is superseded by 4.2. Paragraph 4.2.1 is superseded by 6.2.2. Paragraph 5.4.1 is superseded by 6.2.1.

6.0 TRACK CONTROL

6.1 Model 6041X

6.1.1 Record Head

Record a 1.000 Hz signal from a generator well above optimum recording level in stereo A-test on tracks 1 and 3 for approx. 5 seconds. Turn the tape around and make

a similar recording on tracks 4 and 2. Cut the tape and dip it into a mixture of fine grained iron oxyde powder and alcohol (Magna See solution) to make the recording visible. The spaces between the recorded tracks should be distributed equidistant across the tape, ref. fig. 6.1. Readjust the height position, if necessary, and recheck the azimuth alignment.

6.1.2 The Erase Head

Insert a full-track prerecorded tape and record a 1.000 Hz signal from a generator, well above optimum recording level in mono on track 3 (channel R). Cut the tape and dip it into the Magna See solution. Check that the prerecorded track is in the centre of the erased area, ref. fig. 6.2. Adjust the vertical position of the erase head if necessary.

6.1.3 Playback Head

Record a 1.000 Hz signal on track 1 (channel L) and a 500 Hz signal on track 3 (channel R) at optimum recording levels. Turn the tape around and play back track 2 (channel R) at maximum volume. No signal should be heard. Raise the playback head if the 1.000 Hz signal is heard. Lower the playback head if the 500 Hz signal is heard. Recheck the azimuth position.

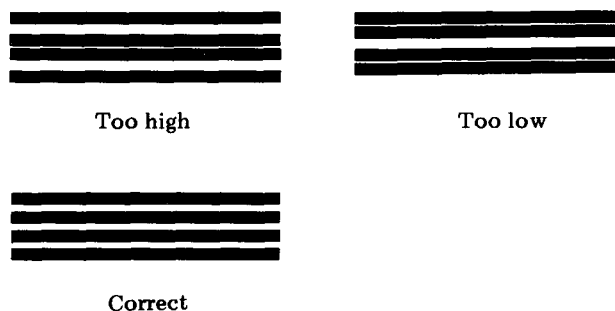

Fig. 6.1 Track measurement of record head

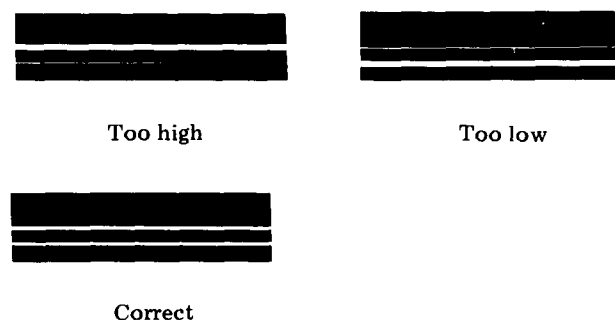

Fig. 6.2 Track measurement of erase head

6.2 Model 6021X

6.2.1 Erase Head

The height of the erase head is aligned by the adjustment screws (K and L) ref. fig. 3.1. Record a 1.000 Hz signal in stereo well above optimum recording level on a full-track prerecorded tape. Dip the tape in the Magna See solution and check that the tracks are distributed symmetrically across the tape. Readjust the erase and the record heads, if necessary.

6.2.2 Record Head

The height of the record head is aligned by the height adjustment screws (C). Record a 1.000 Hz signal in stereo well above optimum recording level on a full-track prerecorded tape. Dip the tape in Magna See solution and check that the tracks are distributed symmetrically across the tape. Readjust the erase and the record heads, if necessary.

6.2.3 Playback Head

The height of the playback head is aligned by the height adjustment screws (A). The tape shall run parallel with the upper edge of the lamination for channel L. Readjust the azimuth position if necessary.

7.0 ADJUSTMENT AND CONTROL OF THE AMPLIFIERS.

7.1.1 Playback Level Adjustment

Connect a VTVM to each one of the phono outputs, and turn the playback volume controls to maximum. Set the recorder for 7 1/2 ips playback of Tandberg test tape No. 4 and adjust R150 (L) and R250 (R) for 1.5V reading on both vacuum tube voltmeters.

7.1.2 Adjustment of Bias Current

Insert a new reel of good quality tape (Low Noise). Connect a VTVM to Line Output terminals, and signal generator to Line Input terminals and set the generator for 1.000 Hz and 0.5 volt. Set the Output Level Controls to maximum and adjust the Record Level Controls to 150 mV deflection on VTVM. Set the tape recorder for stereo recording. Adjust R407 to maximum deflection on left channel VTVM, and R410 to maximum on right channel VTVM.

Note: The 2-track model is also equipped with individually tuned bias- and erase heads. The values of C407, C408 and C126, C226 are labelled on the bias- and erase heads, respectively. The capacitances are given in pF. Upper number refers to upper track.

7.1.3 Record Level Adjustment

Insert a new tape and record a 400 Hz signal at 7 1/2 ips in A-test. Adjust the recording levels for a VTVM indication of 1.5V at both phono outputs. Depress the playback buttons (B-test) and adjust the recording current by means of R108 (left channel) and R208 (right channel) until an output voltage of 1.5 V is obtained.

7.1.4 Record/Playback Curves

Ref. para. 8.2 for adjustment and control of record/playback curves.

7.1.5 Indicator Adjustment in Record Mode

Setting of levels, the same as in paragraph 7.1.3. Adjust R124 for a 0 dB reading on left record level indicator and set R224 for the same reading on right indicator. Release both playback buttons and check that the output voltage is still 1.5 V for both channels.

7.1.6 Distortion

Connect signal generator 400 Hz, 0.5 V and distortion meter to outputs. Record in B-test on both channels. Adjust Record Level controls to 0 dB deflection on indicators. Check distortion to be less than 3%. If distortion exceeds 3%, readjust recording level and indicator, ref. paras. 7.1.3 and 7.1.5.

7.1.7 Indicator Adjustment in Playback and Amplifier Modes.

Set the tape recorder in stereo preamplifier mode, and check that the vacuum tube voltmeters read 1.5V on phono output. Adjust R422 (L) and R445 (R) until both level indicators read 0 dB.

7.1.8 Control of Playback Amplifier

Play back Tandberg test No. 3. This is a full track prerecorded tape with the following frequencies: 250-10.000-5.000-1.000-100-50-250Hz recorded at 7 1/2 ips tape speed. The tape conforms with the N.A.B. standard. The output tolerances are: 10 kHz: 0 - + 4 dB, 5 kHz: + 1 - + 3 dB. The other frequencies have tolerances ± 2 dB. The difference in level between the two channels should be less than 3dB.

7.2 Tape Speed Control

7.2.1 Using Frequency Meter or Counter.

Connect a frequency meter or counter to phono Output and play back Tandberg test tape No. 11 (1,000 Hz) at 7 1/2 ips tape speed. Difference from correct tape speed is indicated in %.

Tolerance: $\pm 1\%$

7.2.2 Using Transformer and Vacuum Tube Voltmeter

Connect a transformer 115/0.5 V or 230/0.5 V, 50/60 Hz and a VTVM to the phono Output and the mains as shown in fig. 7.1. Play back Tandberg test tape No. 10 a (mains frequency 50 Hz) or No. 19 a (mains frequency 60 Hz) at 7 1/2 ips tape speed.

Deviation from correct tape speed will give a beat across the VTVM. Turn the Output Level Control to obtain adequate meter deflection.

Clock the time for 10 complete excursions of the meter needle.

Read the speed deviation in per cent corresponding to this particular time from the nomogram in fig. 7.2.

Brake left hand turntable slightly to decide if tape speed is too high or too low. Increased deviation indicates too low tape speed.

At 3 3/4 ips, play Tandberg test tape No. 10 b (50 Hz mains frequency). Proceed as for 7 1/2 ips to find speed accuracy.

Speed tolerance: $\pm 1\%$.

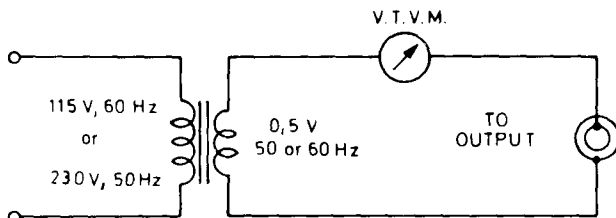

Fig. 7.1

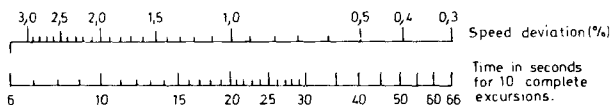

Fig. 7.2

7.2.3 Using Tape of Known Length

Insert a tape of known length 450'' (1144 cm) and play it back. Time taken for the whole length should be:

7 1/2 ips: 60 seconds

3 3/4 ips: 120 seconds

1 7/8 ips: 240 seconds

Tolerance: 1 %.

8.0 ADJUSTMENT OF THE AMPLIFIERS WITHOUT TANDBERG TEST TAPES

8.1 Playback and Record Level Adjustment

Connect a VTVM to each output terminal. The signal generator is connected to the Line Input of both channels and tuned to 400 Hz.

The tape recorder is set up for stereo recording A-test, at 7 1/2 ips tape speed. Insert a good quality tape (Low Noise).

Adjust the recording gain controls until the reading on the output meters are 1.5 V with the playback controls to maximum. Replace the VTVM for channel L with a distortion meter and depress the playback push button (B-test). Adjust the recording current by R108 until the reading shows 3 % distortion.

Replace the VTVM for channel R with the distortion meter and depress the push button playback R (B-test). Adjust the recording current by R208 until the reading shows 3 % distortion. Connect a VTVM to each output terminal and proceed the recording as described above in stereo B-test.

Adjust R150 (channel L) and R250 (channel R) until the reading on the output meters are 1.5 V. Make sure that the playback volume controls are set to maximum. Release the push-buttons Playback L and R (Stereo A-test) and check that the reading on the output meters still are 1.5 V.

8.2 Record/Playback Curves

Connect a VTVM to each one of the phono outputs L and R. In order to avoid interference from the oscillator voltage, a band stop or a low pass filter tuned to 85.5 kHz must be inserted between the output and the voltmeters.

Set the tape recorder for 3 3/4 ips stereo recording, level 30 dB below optimum (0 dB). Use the output VTVM reading as reference levels.

Then record a 16,000 Hz signal at the same level and check that the output voltage is within ± 2 dB. If the voltage is too high, increase bias current by means of R407 for channel L and R410 for channel R.

If the voltage is too low, alter the input signal frequency to 1,000 Hz and adjust for maximum output voltage by means of R407 and R410 for channels L and R respectively. Then go back to 400 Hz, reestablish the reference level, and recheck the output level at frequencies between 50 and 16,000 Hz do not deviate more than ± 2 dB from reference level.

Perform the same check for 7 1/2 ips at frequencies between 40 and 20,000 Hz, and then finally check for 1 7/8 ips between 50 and 9,000 Hz. Ref. level 400 Hz.

The output levels of the two channels should not at any frequency differ by more than 3 dB.

8.3 Readjustment of Recording Levels and Indicators

For readjustments of recording levels and indicators ref. paragraph 7.1.3 and 7.1.4.

8.4 Distortion

Ref. para. 7.1.6 for adjustment and control of distortion.

8.5 Control of Playback and Record Amplifiers

If the specified tolerances for frequency response are exceeded, check the playback and record amplifiers.

8.5.1 Playback Amplifier

Connect a signal generator in series with a 1 kohm resistor and a 100 uF capacitor and playback head, see fig. 8.1.

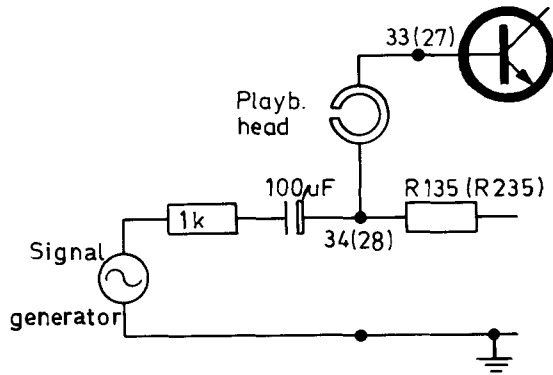

Fig. 8.1

Connect also VTVM to each of the Line Outputs and set playback volume control to maximum. Set the tape recorder for stereo playback. To ensure correct signal level, apply oscilloscope. Tune the generator to 400 Hz and adjust the level to 20 dB below 1.5 V, i.e. 150 mV. Check the frequency response according to fig. 8.2.

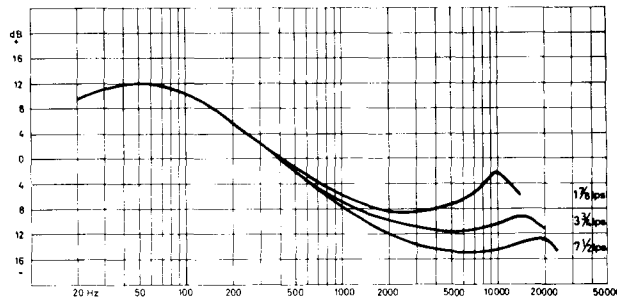

Fig. 8.2 Playback curves

8.5.2 Record Amplifier

Connect a VTVM to each one of the head-halves as shown in fig. 8.3 and a signal generator to Line Input for each channel. Short-circuit trimming capacitor C404 in oscillator. Set the tape recorder for stereo recording, with input selectors to Line position. Set the level 30 dB below 0 dB indicator deflection i.e. 20 dB down on signal generator, and 10 dB down by means of Record Level Controls. Use 400 Hz as reference on VTVM deflection. Check the frequency response according to fig. 8.4.

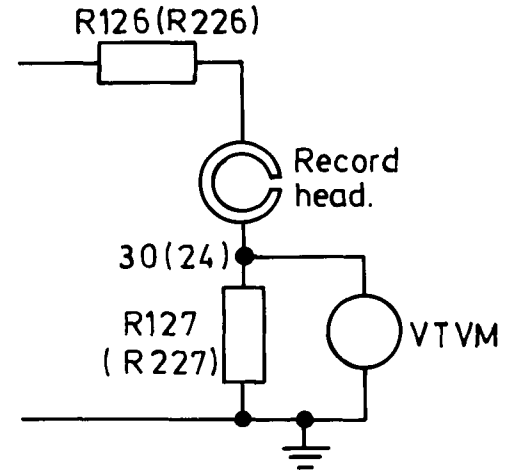

Fig. 8.3

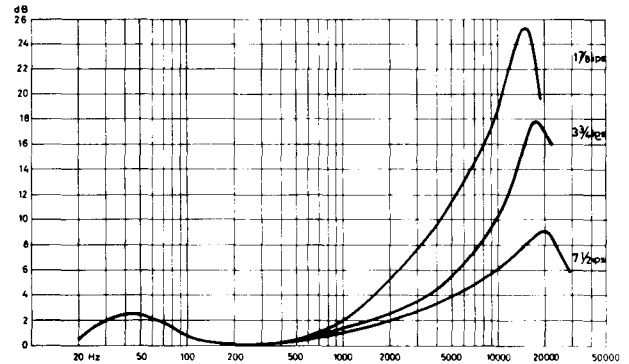

Fig. 8.4 Recording curves

8.6 Pick-up Amplifier Curve

Set the input selector in position PICK UP and the pick-up selector in position MAGN. Leave all buttons unoperated (stereo amplifier mode). Output Volume Controls to maximum. Set signal generator to 400 Hz. Adjust with Record Level Controls to 150 mV output on VTVM (1.5 V - + 20 dB). Check by means of voltmeters connected to the phono output that the frequency response conforms within a tolerance of 2 dB with the RIAA curve shown in fig. 8.5.

ELECTRONIC SERVICE CENTER

A DIV. OF ENVIRONMENTAL INC.

862 HILLWOOD BLVD.

NASHVILLE, TENN. 37203

(615) 252-6666

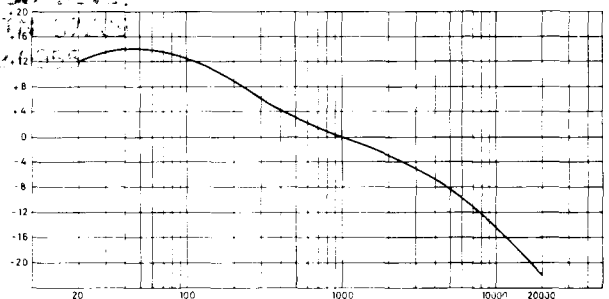

Fig. 8.5 RIAA curve for magnetic pick-up

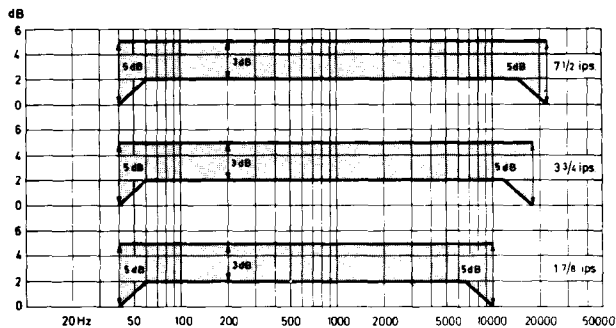

Fig. 8.6 Total frequency response tolerances according to DIN 45511

8.7 Limiter

Set both volume controls to maximum.

8.7.1 Adjustment of Limiting Threshold

Set the input and output controls to maximum. Feed 400 Hz signals into the Line Inputs in amplifier mode and set the level to 0 dB on the indicators. Depress LIMIT button and adjust both R320 for ± 1 dB reading on the indicators. Increase the input 20 dB and check that indicator reading does not increase by more than approx. 2 dB.

8.7.2 Adjustment of Release Time

Connect an oscilloscope with calibrated time scale to the phono output. Feed 400 Hz signals into the line input, and set signal levels for 0 dB reading on the indicators. Depress LIMIT button, and increase the signal level by 20 dB. Then abruptly decrease the level by 20 dB, and determine by means of the oscilloscope pattern the time taken for the output signal to return to approx. 1 dB below normal level on indicator. See fig. 8.7. Adjust the time to 0.7 s by means of R311.

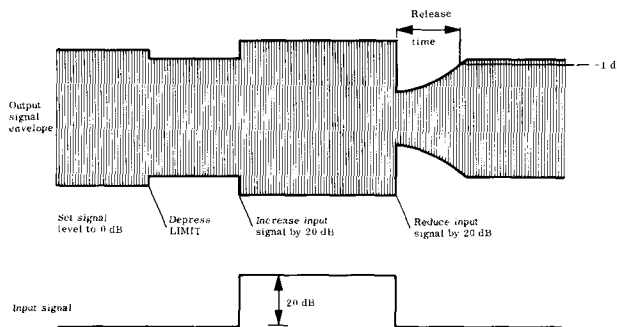

Fig. 8.7

9.0 MODIFICATIONS

9.1 Modification from 230/115V 50 Hz to 230/115V 60 Hz operation

The transformer must be rewired when changing from 50 Hz to 60 Hz or 230V to 115V operation, while motor pulley and motor capacitor have to be changed. Connect as shown in fig. 9.1—9.2 and description below.

230V connections

230V, 50 Hz: Motor pulley, part No.: 245771. Motor capacitor: 2 μ F, oil paper 5% 320V. Clamp for motor capacitor, part No.: 263184.

230V, 60 Hz: Motor pulley, part No.: 247452. Motor capacitor: 1,5 μ F, oil paper 5% 320V. Clamp for motor capacitor, part No.: 263184.

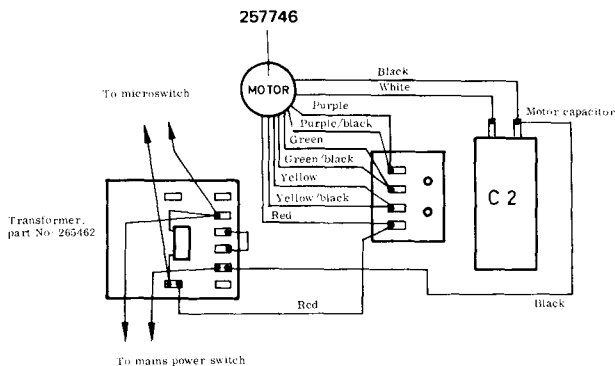

Fig. 9.1 230 V motor and transformer connections

115V connections

115V, 50 Hz: Motor pulley, part No.: 245771. Motor capacitor: 8 uF, oil paper 5 % 220V. Clamp for motor capacitor, part No.: 991040.

115V, 60 Hz: Motor pulley, part No.: 247452. Motor capacitor: 6,5 uF, oil paper 5 % 220V. Clamp for motor, part No.: 206713.

When ordering motor pulley or clamp for motor capacitor, specify the part number.

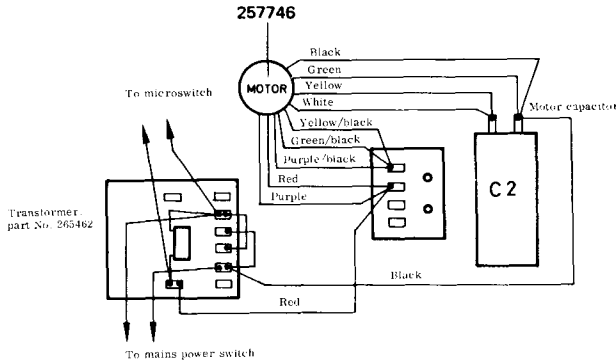

Fig. 9.2 115 V motor and transformer connections

9.2 Modification from Four-Track to Two-Track Version

The following components have to be changed when modifying from four-track to two-track. The value of total capacitance is labeled on two-track heads.

Part	Four-Track	Two-Track
Record head	C04-11R	F82-07R
Playback head	C03-10P	F83-11P
Erase head	D84-18E	D87-20E
Bias head	D90-03B	D92-04B
C126	250 pF	} Add capacitance until value labeled on head is obtained
C226	250 pF	
C407	3300 pF	
C408	3300 pF	

The numbers indicating the heads are ordering numbers for the heads.

9.3 Important Electrical Modifications Introduced in Series 6000X

From serial number 2803700 output impedance were altered from 10 kohm to 5 kohm to meet DIN specifications 45511. The following components were modified:

- R423 changed from 22 kohm to 10 kohm
- R428 changed from 22 kohm to 10 kohm
- R429 changed from 22 kohm to 10 kohm
- R432 changed from 22 kohm to 10 kohm
- R434 changed from 82 kohm to 47 kohm
- R435 changed from 10 kohm to 5,6 kohm
- R436 changed from 82 kohm to 47 kohm
- R437 changed from 10 kohm to 5,6 kohm

From serial number 2803010 the following modifications were introduced in the limiter circuit:

Resistors R314 (10 kohm) were omitted and replaced by capacitors C327 (2 uF). Resistors R346 (100 kohm) were introduced from base to emitter of Q305.

10.0 LUBRICATION

The Motor:

The motor should be lubricated after approximately every 3000 hours of use.

The upper and the lower bearing should be lubricated with a Teresso oil 43 or 47 from Esso.

The Self Lubricating Bearings:

The turntables, the flywheel and the speed transfer-wheel are mounted in self lubricating bearings and should usually not be lubricated. If, however, it should be necessary to lubricate the bearings for any reason, use Teresso oil 43 or 47 from Esso.

Note: Utmost care must be taken while lubricating. Use only one fractional drop of oil for each bearing. Excessive oil might seriously affect the friction drive.

11.0 ILLUSTRATIONS WITH REFERENCE PART NUMBERS

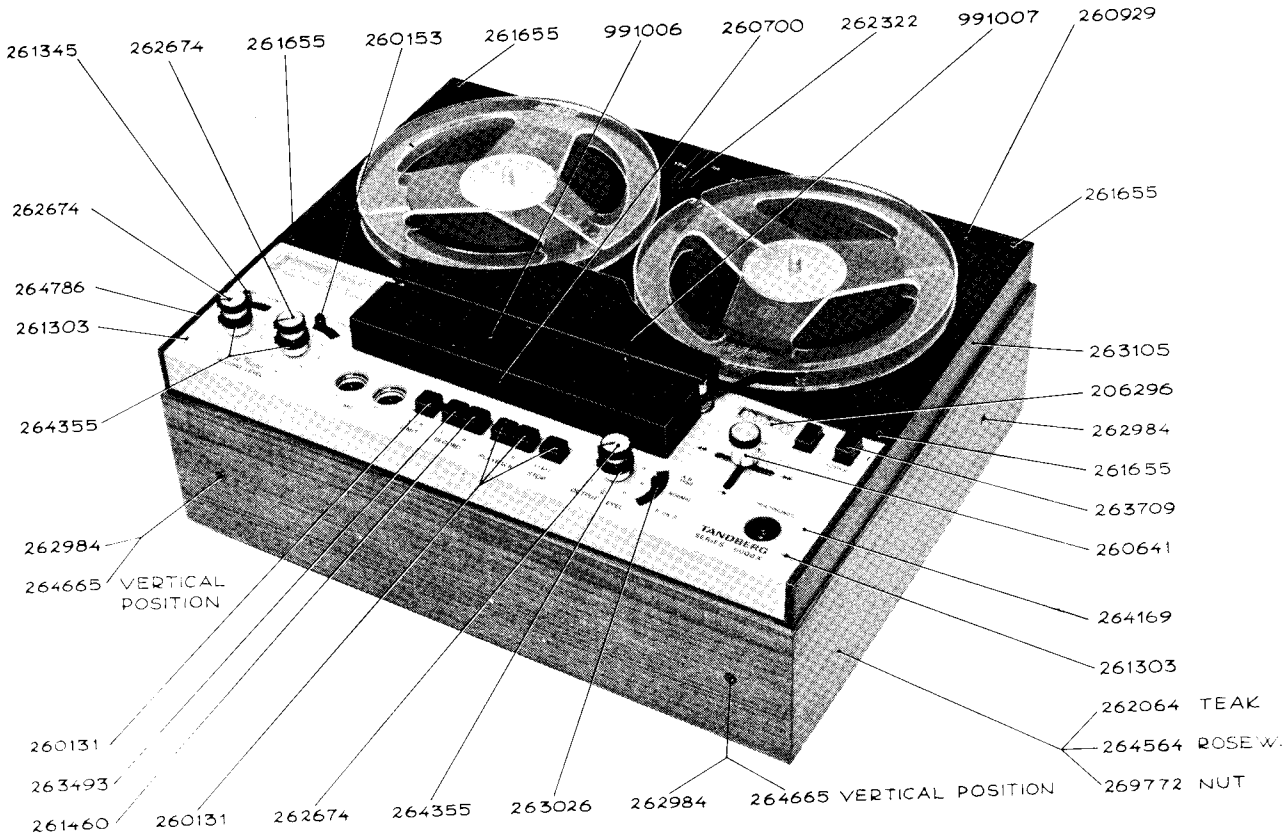
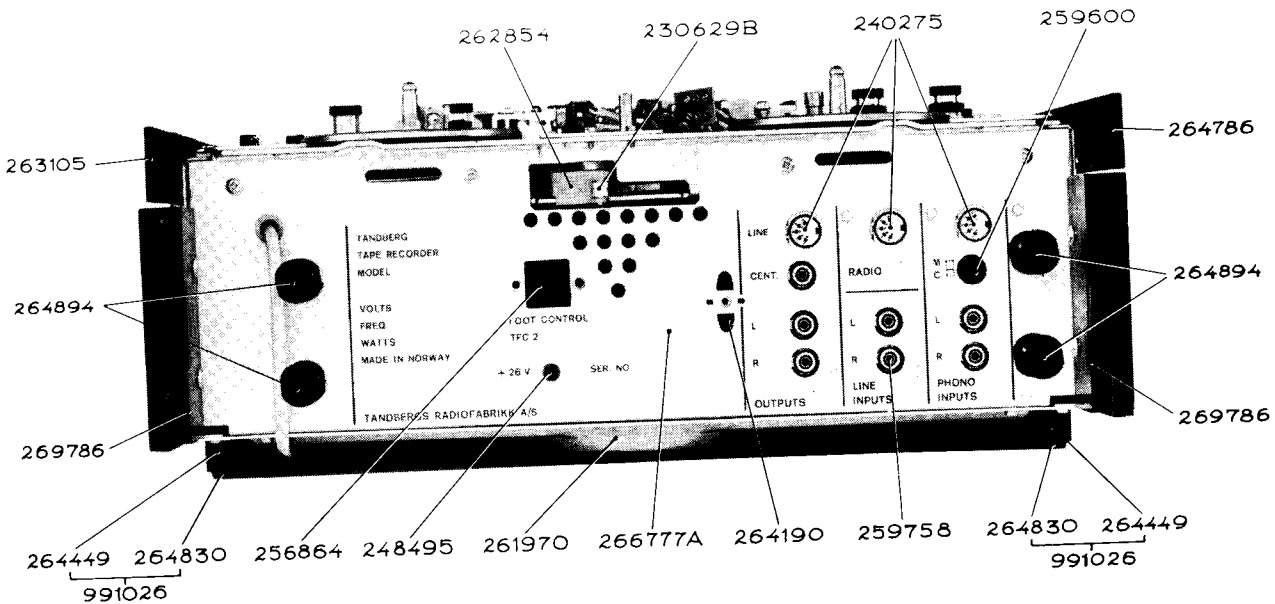

Fig. 11.1. Top exterior view



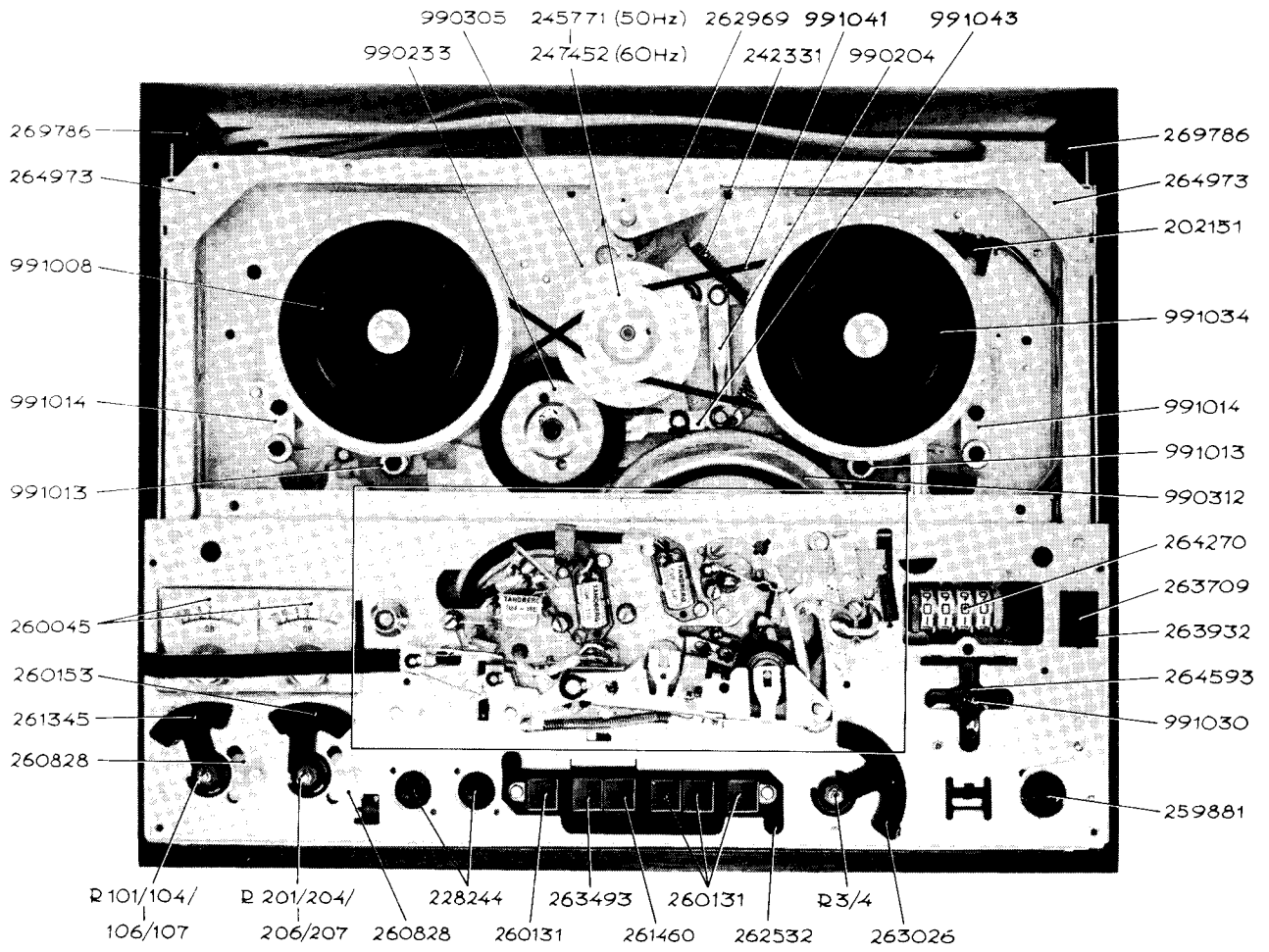

Fig. 11.3. Top view with covers removed

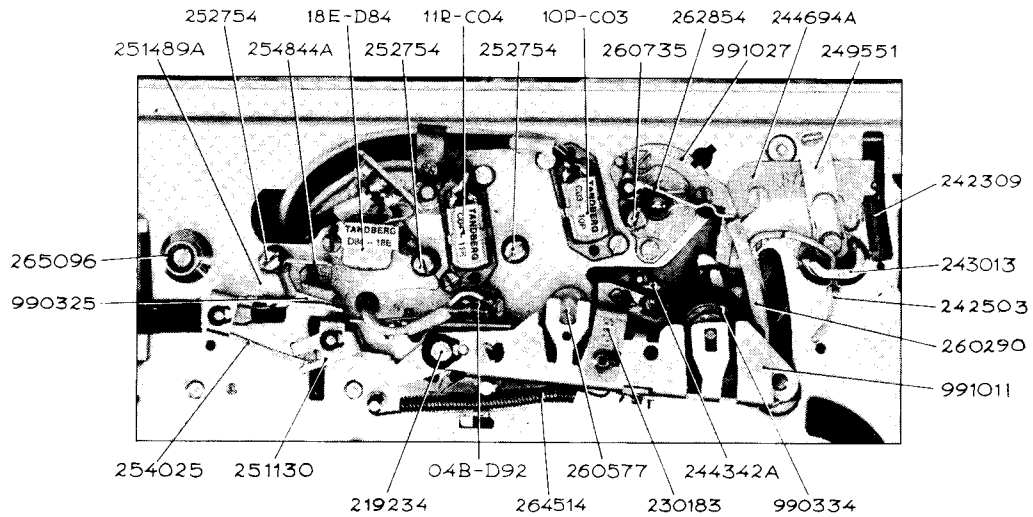

Fig. 11.4. Tape path and pressure roller arm

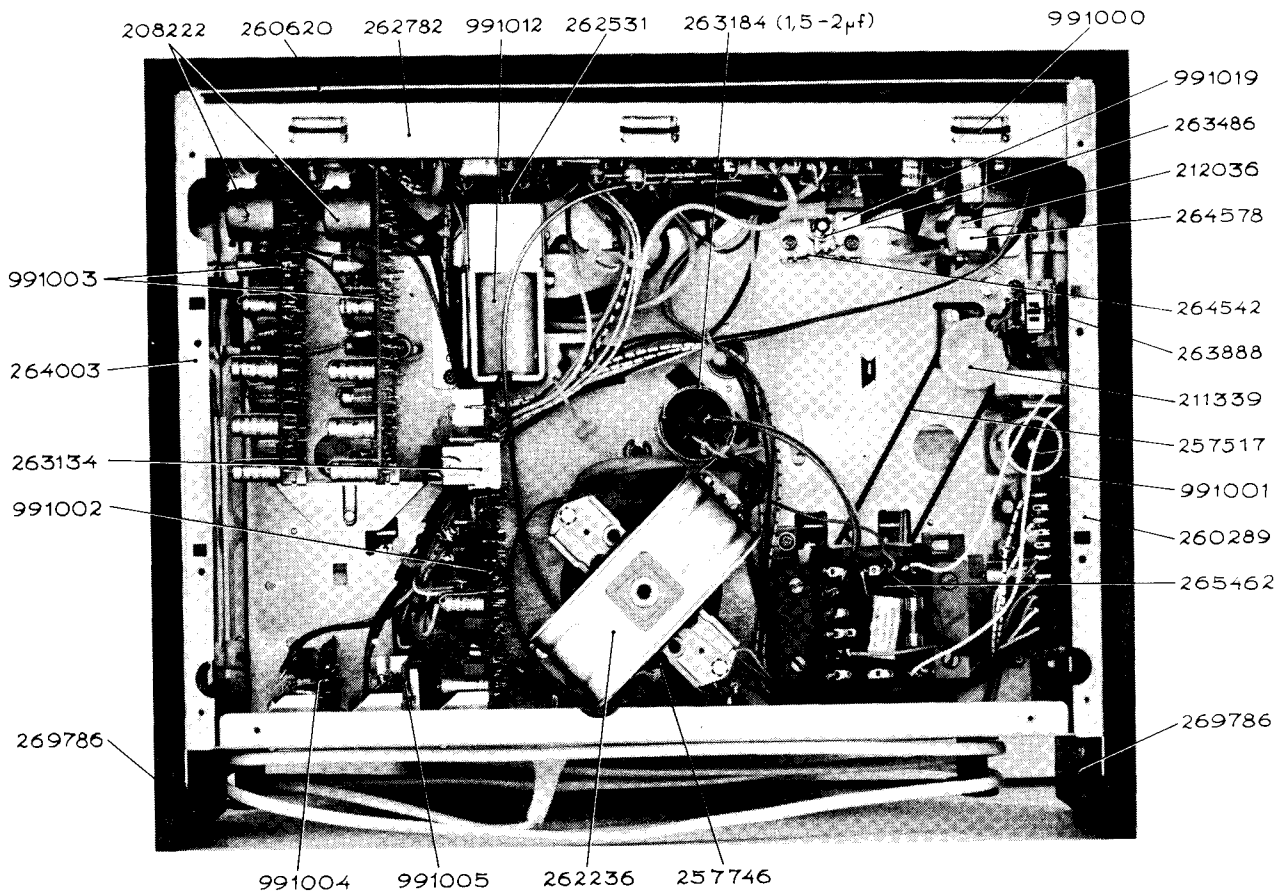

Fig. 11.5. Bottom view

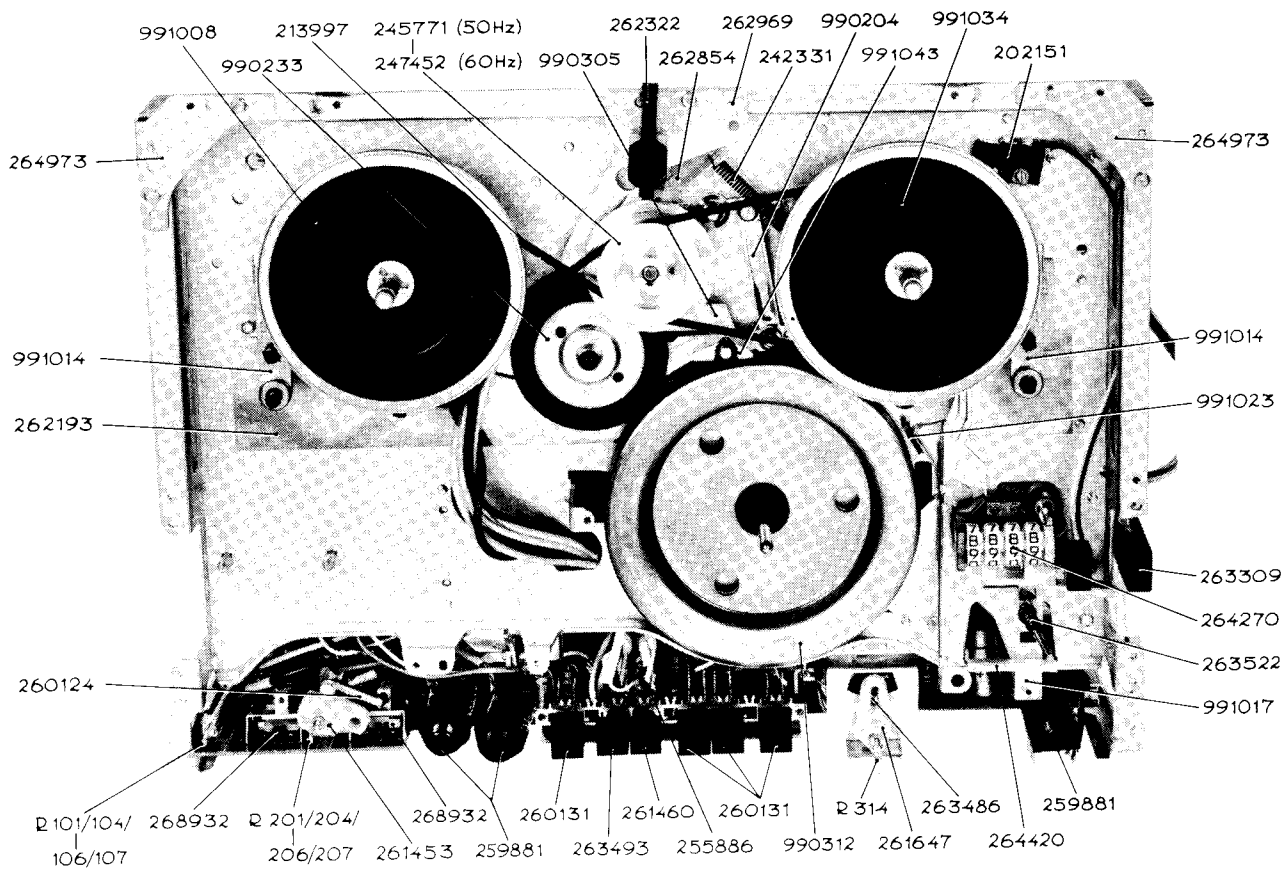

Fig. 11.6. Top view with upper mounting plate removed

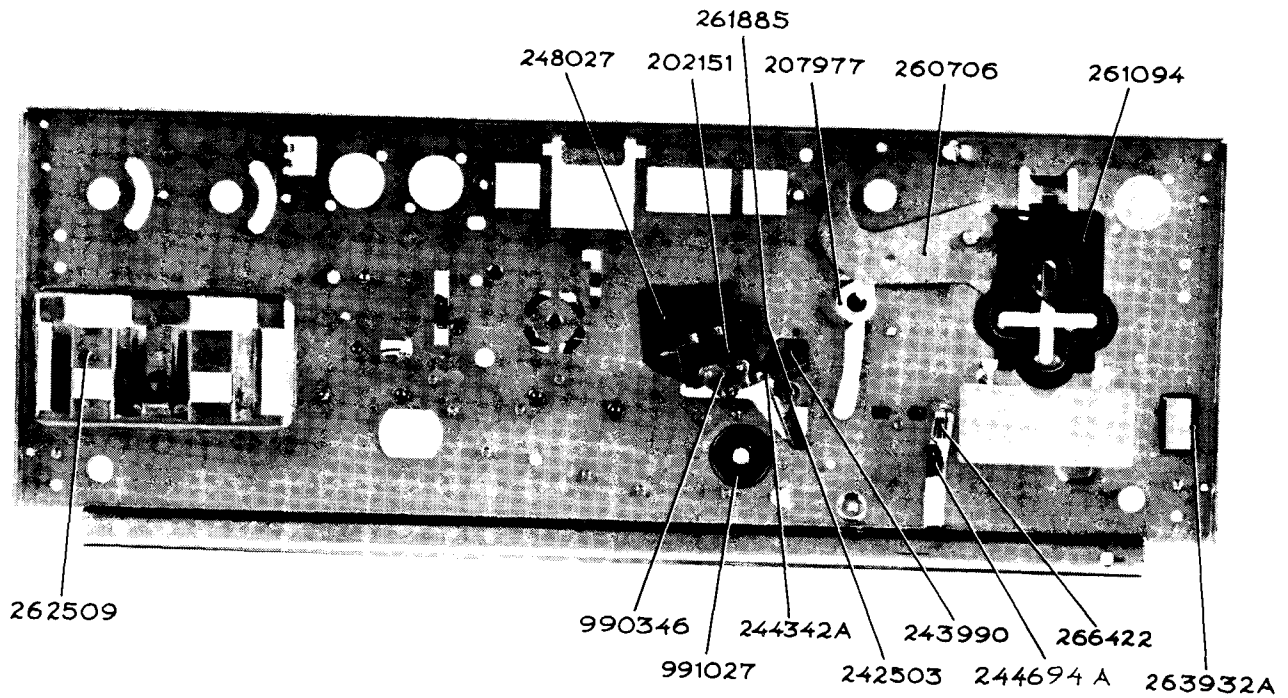

Fig. 11.7. Upper mounting plate seen from underneath

12.0 SPARE PARTS LIST FOR TANDBERG TAPE RECORDER 6000X.

The numbers of the mechanical parts on the figures are identical with the numbers on the parts in store. Parts shown on the figures without existing in the parts list are not available as spare parts.

Note: Apply part reference numbers when ordering spare parts.

12.1 Mechanical parts:

Ref.No.	Description	Usage	Notes
201957	Shaft	Pressure pad arm	
202008	Mains cable	115 V, 7FT	
202151	Microswitch		
202309	Shaft	Eccentric segment	
203250	Mains cable	230 V 220cm w/plug	
206296	Window	Counter	
206713	Clamp	Motor capacitor 6,5uF	
207977	Roller	Eccen. segment	
208222	Transformer	Microphone T301	
208724	Clamp	Mains cable	
209306	Spring	Transfer wheel arm	
211339	Pulley	Revolution counter	
211418	Shaft	Lever	
212036	Holder	Operating lever	
212066	Nut	Cabinet	
215953	Pulley	Turntable	
216599	Fin	Cooling	
217783	Retainer	Tape reel	
218767	Nut	Turntable shaft	
219234	Shaft	Pressure roller arm assembly	
219816	Flange	Turntable housing L&R	

Ref. No.	Description	Usage	Notes
224185	Screw	Vertical mounting feet	
224795	Support	Sound-on-Sound switch	
228244	Connector	Microphone	
230183	Shield	Playback head	
230629B	Roller	Stop arm	
234960	Washer	Speed selector shaft	
237482	Spring	Support, erase head	
240275	Connector	Radio - P.up - Line	
240276A	Screw	End stop	
240406	Spring	Record-playback head adj.	
240879A	Plate	Transfer wire	
242309	Spring	End stop, transfer arm	
242331	Spring	Cam disc arm	
242503	Arm	End stop	
243013	Tape guide	Right	
243150	Arm	Bias head	
243990	Spring	End stop arm	
244342A	Arm	End stop switch	
244694A	Lever	End stop	
245354	Suppressor	Start-stop switch	
245771	Pulley	Motor, 50 Hz	
246231	Clamp	End stop switch wires	
246691	Washer	Rec. potm.	
247395	Clip	9 mm (3/8")	
247452	Pulley	Motor, 60 Hz	
247941	Shaft	Pressure roller	
248027	Insulator	End stop switch	
248157	Bushing	Adj. tape guide	
248495	Connector	26 V	
249306	Suppressor	End stop switch	
249551	Guide	End stop lever	
249737	Clip	12.5 mm (1/2")	
251130	Link	Pressure pad arm	
251489A	Arm	Tape rest	
252115	Switch	Equalization	
252172	Bearing	Flywheel	
252496	Clamp		
252754	Tape guide	Adj.	
254025	Arm	Pressure pad	
254844A	Support	Pressure pad/tape	
255886	Push button switch	Assy.	
256864	Connector	Remote control	
257517	Drive belt	Counter	
257746	Motor	115/230 V 50/60 Hz	
259529	Lamp	Counter and meter. 24 V 1W	
259600	Selector switch	Pick-up	
259758	Connector	Phono	
259773	Plate	Fastening, printboard	
259881	Jack	Microphone, US version	
260045	Meter	Record and playback level indicator	
260124	Transfer arm	Input switch	
260131	Button	Limiters-playback-stop	
260153	Arm	Input switch control, right	
260289	Side plate	Right	
260290	Tape support	Neut. position	
260361	Friction ring	Clutch L&R	
260421	Washer	Neoprene, start/stop solenoid	
260476	Spring	Input switch	
260577	Bearing	Flutter filter	
260620	Panel	Front	
260641	Knob	Operating lever	
260700	Knob	Cueing control	
260706	Eccentric arm		
260735	Screw	Tape guide	
260828	Bracket	Support, input switch	
260850	Lever	Start/stop solenoid	
260929	Cover plate	Rear	
260950	Terminal plug	7 pins	

Ref. No.	Description	Usage	Notes
260965	Spring	Cueing arm	
261051	Socket	Lamp meter	
261072	Tension spring	Pressure roller cover	
261094	Guide	Operating lever, pc.	
261216	Adj. screw	Clutch-and-breake levers	
261302	Terminal connector	7 pins	
261303	Screw	Cover front	
261345	Input switch	Control arm, left	
261453	Input switch	Stop control	
261460	Button	Record, right channel	
261525	Stud	Lifting arm	
261647	Transfer arm	Control Sound-on-Sound switch	
261655	Screw	Cover rear, japanned	
261805	Coil spring	Left clutch disc	
261841	Coil spring	Clutch and brake levers	
261885	Screw	End stop, feeler arm	
261913	Spacer	Pick-up switch	
261970	Cover	Bottom	
261992	Disc	Thrust, bearing flywheel	
261999	Spacer post	Push button assy.	
262064	Cabinet	Teak	
262157	Spacer	Push button assy.	
262193	Slide plate	Stainless steel	
262215	Shield	Line input board	
262236	Clamp	Support, motor	
262244	Steel ball	Transfer arm input switch	
262258	Roller	Flutter filter	
262322	Knob	Speed selector	
262402	Contact spring	Counterlamp holder	
262481	Arm	Tape brake	
262509	Lamp shield		
262531	Armature	Start/stop solenoid	
262532	Guide plate	Push buttons	
262545	Holder	Speed selector arm spring	
262674	Knob	Upper, rec/output lever control	
262739	Spring	Lower, operating lever	
262782	Frame	Main board holder	
262833	Spring	Pull rod	
262854	Arm	Speed selector	
262969	Plate	Speed selector	
262983	Terminal plug	3 pins	
262984	Screw	Cabinet 5/8"	
263026	Control arm	Switch, Sound-on-Sound	
263105	Side plate	Right	
263134	Bracket	PC boards	
263184	Clamp	Motor capacitor 1.5—2uF	
263278	Bracket	Power switch	
263335	Plate	Retainer, flywheel bearing, lower	
263486	Transfer arm	Sound-on-Sound switch	
263493	Button	Record left	
263522	Spring	Upper, operating lever	
263688	Screw	Topplate. 3 x 8 mm countersunk	
263709	Button	Power switch	
263817	Switch	Sound-on-Sound	
263838	Spacer	Function selector switch, small	
263874	Bushing	Plastic, operating lever	
263888	Power switch	Without button	
263896	Shield	Radio connector	
263932	Guide	Power switch button	
264003	Side plate	Left	
264054	Spring	Bias head arm	
264083A	Tube	Friction disc	
264126	Spacer	Neoprene, start/stop solenoid	
264162	Tape brake	Insure rubber	
264169	Top plate	Front	
264190	Holder	Mains plug, rear panel	
264212	Screw	Start/stop solenoid adj.	
264226	Guide	Slidearm	
264370	Counter		
264355	Knob	Lower, rec/out level contr.	
264420	Sleeve	Slide arm damping	
264427	Wafer	Sound-on-Sound switch	
264485	Insulator	Motor terminal	

Ref. No.	Description	Usage	Notes
264514	Spring	Pressure roller arm	
264542	Spring	Sound-on-Sound switch control arm	
264564	Cabinet	Rosewood	
264578	Bracket	Operating lever	
264593	Bushing	Stop, operating lever	
264645	Screw	Vert. mount	
264664	Terminal plug	4 pins	
264830	Foot	Insert rubber	
264866	Spring	Tape brake arm	
264894	Holder	Mains cord	
264909	Post	Spring pressure roller arm	
264930	Bracket	Braking lever	
264973	Stay plate	Rear corners	
265096	Tape guide	Left	
265462	Transformer	Power, T1, 115-230V	
266072	Cover	Rear	
266309	Sleeve	End stop lever	
266496	Coil	Start-stop solenoid	
266777A	Panel	Rear	
267373B	Coil spring	Right friction disc	
268062	Spring	Pressure pad arm	
268134	Shield	Start-stop solenoid	
268932	Switch	Input selector	
269772	Cabinet	Walnut	
269786	Plate	Fastening rear cover	
990204	Parallel arm	Complete	
990233	Transfer wheel		
990228	Spring	Pressure roller	
990305	Arm	Transfer wheel	
990312	Flywheel	With capstan	
990325	Pressure pad		
990334	Pressure roller		
990346	Bracket w/shaft	End stop	
991000	Main amplifier board	Compl.	
991001	Power supply board	Compl.	
991002	Output amplifier/osc. board	Compl.	
991003	Input preamp board		
991004	Pick-up input board	Compl.	
991005	Line input board	Compl.	
991006	Cover	Pressure roller arm	Valid below Ser. No. 2806200
991007	Cover	Heads	Valid below Ser. No. 2806200
991008	Turntable	Supply	
991009	Clutch	Disc, right	
991010	Clutch	Disc, left	
991011	Pressure roller arm	Assy.	
991012	Start/stop solenoid	Compl.	
991013	Lever	Clutch	
991014	Lever	Braking	
991015	Releasing arm	With pulling rod	
991017	Arm	Clutch and braking slide	
991018	Arm	Cueing	
991019	Bracket	Sound-on-Sound assy.	
991020	Bracket	Start/stop solenoid	
991021	Spring	Turntable, brake left	
991022	Spring	Turntable, brake right	
991023	Spring	Flywheel, brake	
991024	Spring	Capstan, thrust	
991025	Housing	Turntable bearing	
991026	Foot	Plastic with rubber inserts	
991027	Bearing	Upper flywheel, compl.	
991028	Plate	Record interlock	
991029	Termnal strip	Motor	
991030	Operating lever	With ball	
991031	Lamp holder	Counter	
991032	Sound-on-Sound switch slide		
991034	Turntable	Take-up	
991035	Disc	Tape tightening. Take up turntable	
991038	Cover	Pressure Roller Arm	Valid below Ser. No. 2806200
991039	Cover	Heads	Valid below Ser. No. 2806200
991040	Clamp	Motor Capacitor, 8 μ F	
991041	Drivebelt	Rubber	
991043	Holder	Transfer wheel	

12.3.2 Diodes

Ref. No.	Description	Notes	
D201-6000x	1N 4148	Zener diode	
D202-6000x	1N 4148		
D301-6000x	ZF 6,2		
D302-6000x	1N 4148		
D303-6000x	1N 4148		
D401-6000x	1N 4148		
D402-6000x	1N 4148		
D403-6000x	1N 4148		
D501-6000x	ZF 24		Zener diode
D502-6000x	BY 127		

12.3.3 Rectifier

Ref. No	Description	Notes
	B 40 C2200	

12.3.4 Trimming Capacitor

Ref. No.	Description	Notes
C404-6000x	150-750 pF	

12.3.5 Potentiometers

Ref. No.	Description	Notes
R3-6000x	10 kohm	Neg. Logarithmic
R4-6000x	10 kohm	
R101-6000x	50 kohm	
R104-6000x	5 kohm	
R106-6000x	33 kohm	
R107-6000x	5 kohm	
R108-6000x	1 kohm	
R124-6000x	10 kohm	
R150-6000x	4,7 kohm	
R201-6000x	50 kohm	
R204-6000x	5 kohm	Logarithmic
R206-6000x	33 kohm	
R207-6000x	5 kohm	
R208-6000x	1 kohm	
R224-6000x	10 kohm	
R250-6000x	4,7 kohm	
R311-6000x	470 kohm	
R320-6000x	10 kohm	
R407-6000x	10 kohm	
R410-6000x	10 kohm	
R422-6000x	10 kohm	
R445-6000x	10 kohm	

12.3.6 Heads

Ref. No.	Description	Notes
C04-11R	Record Head	Four-Track
F53-11R	Record Head	Four-Track*
C03-10P	Playback Head	Four-Track
D84-18E	Erase Head	Four-Track
G51-18E	Erase Head	Four-Track*
D90-03B	Bias Head	Four-Track
F82-07R	Record Head	Two-Track
F83-11P	Playback Head	Two-Track
D87-20E	Erase Head	Two-Track
D92-04B	Bias Head	Two-Track

* Valid above: Serial No. 280515

12.3.7 Transformers

Ref. No.	Description	Notes
T1-6000x	Mains Transformer	
T301-6000x	Microphone Transformer	
T401-6000x	Oscillator Transformer	

13.0 TRANSISTOR AND DIODE IDENTIFICATION

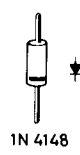
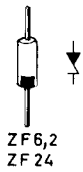
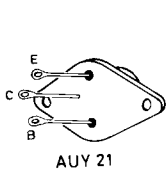
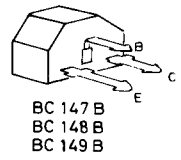
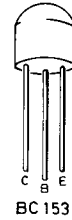
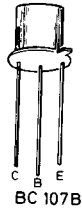
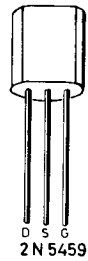
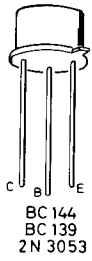

14.0 BLOCK DIAGRAM SERIES 6000X

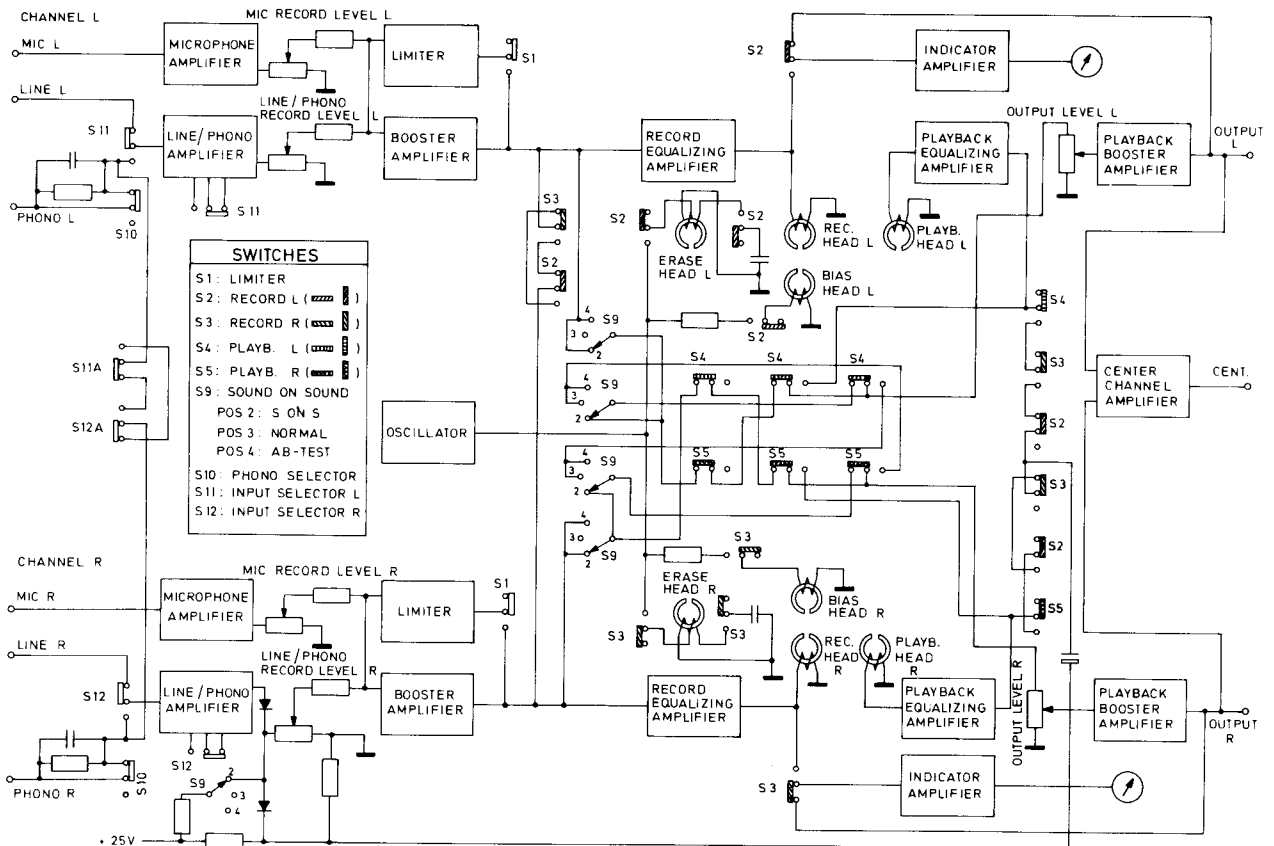

All switches shown in unoperated position. For complete switch identification, see wiring diagram.

15.0 PRINTED WIRING BOARDS AND WIRING DIAGRAM

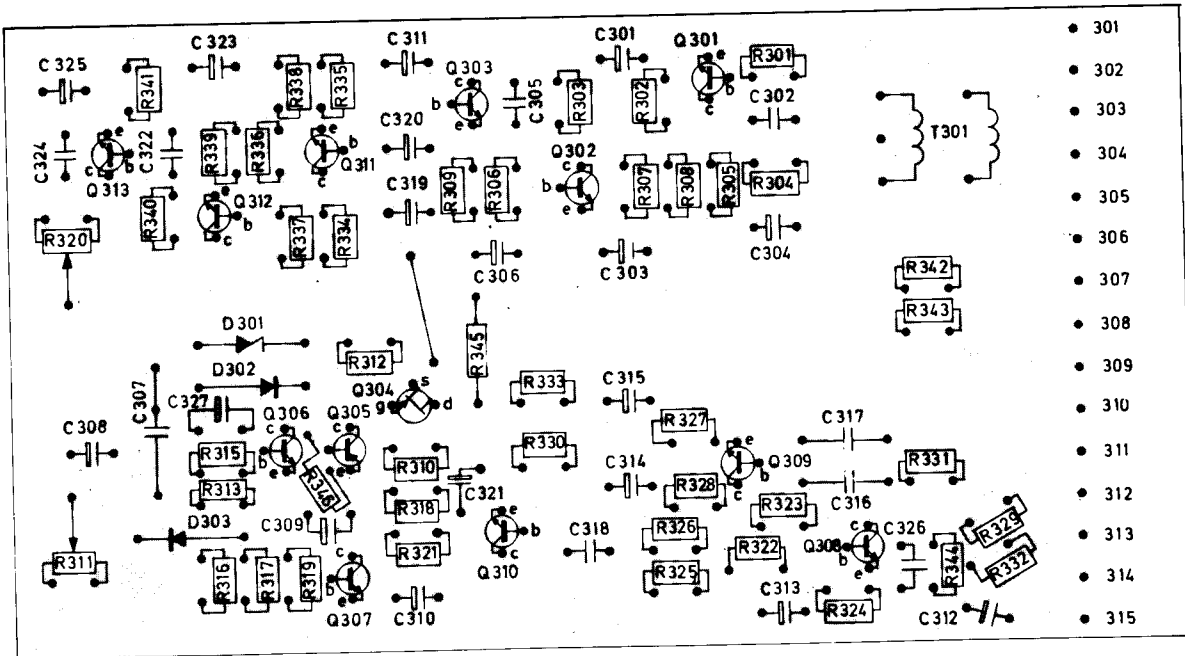

Microphone amplifier-, line/phono amplifier-, limiter- and booster amplifier board seen from printed side. Board No. 18050

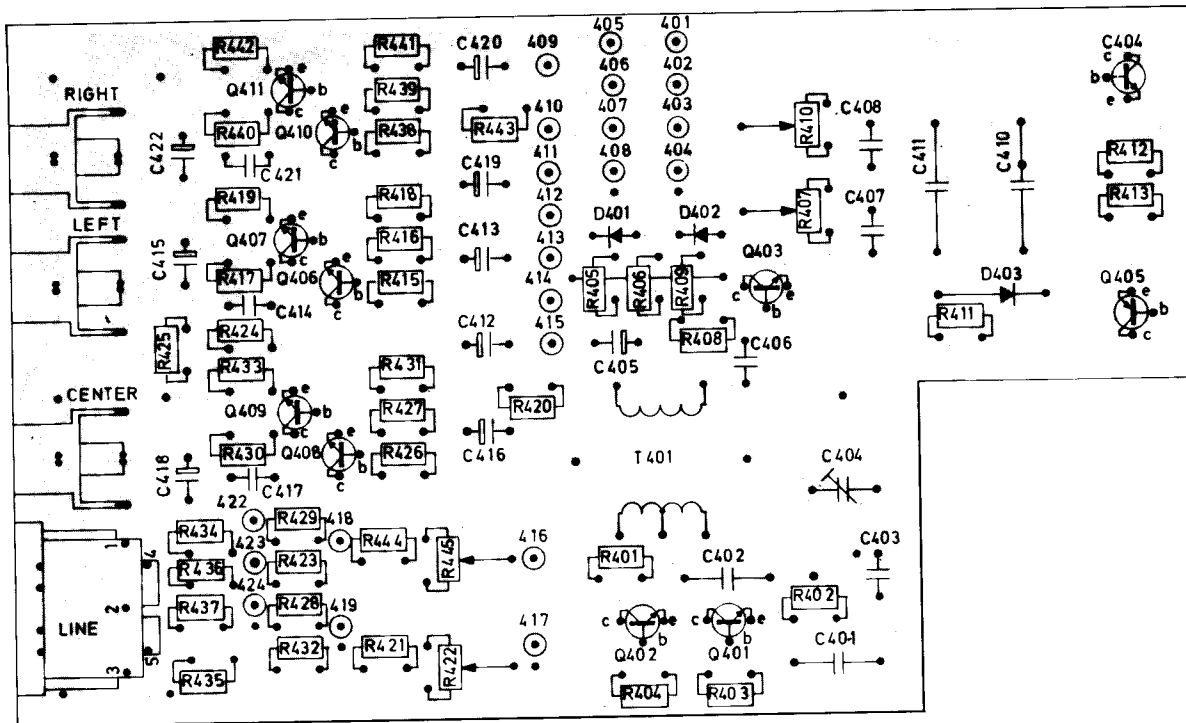

Playback amplifier — and oscillator board, seen from printed side.
Board No. 18044

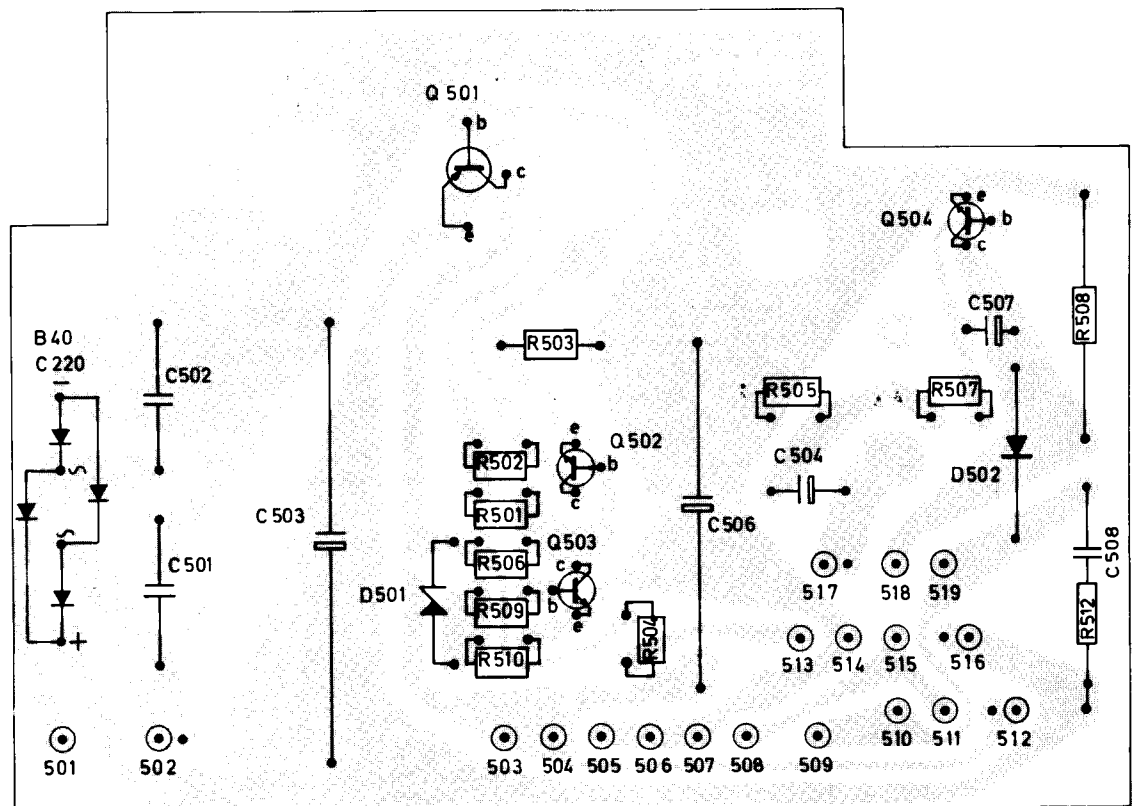
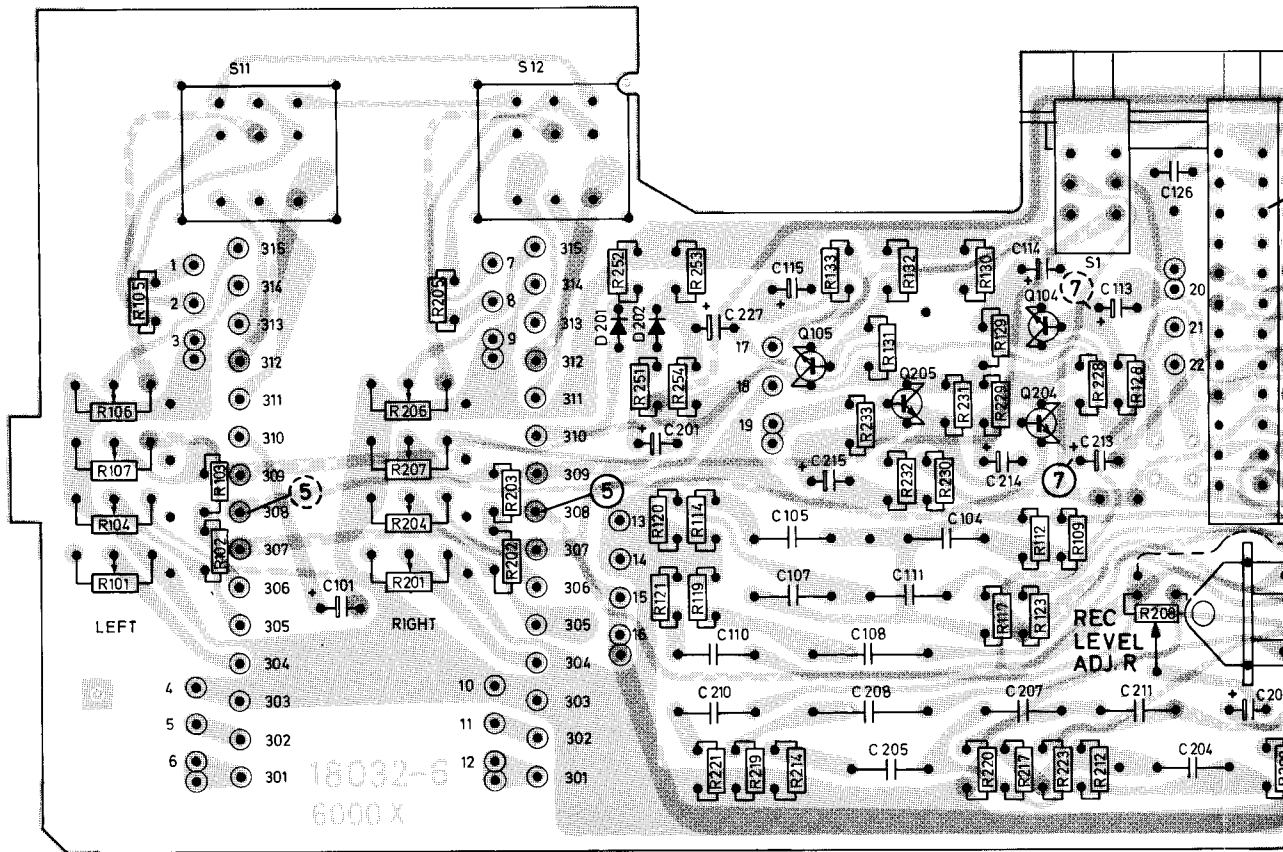

Rectifier board, seen from printed side. Board No. 18038

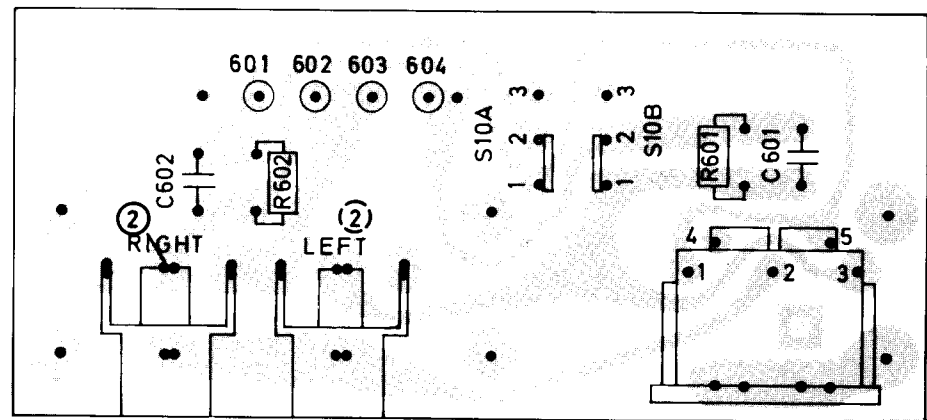
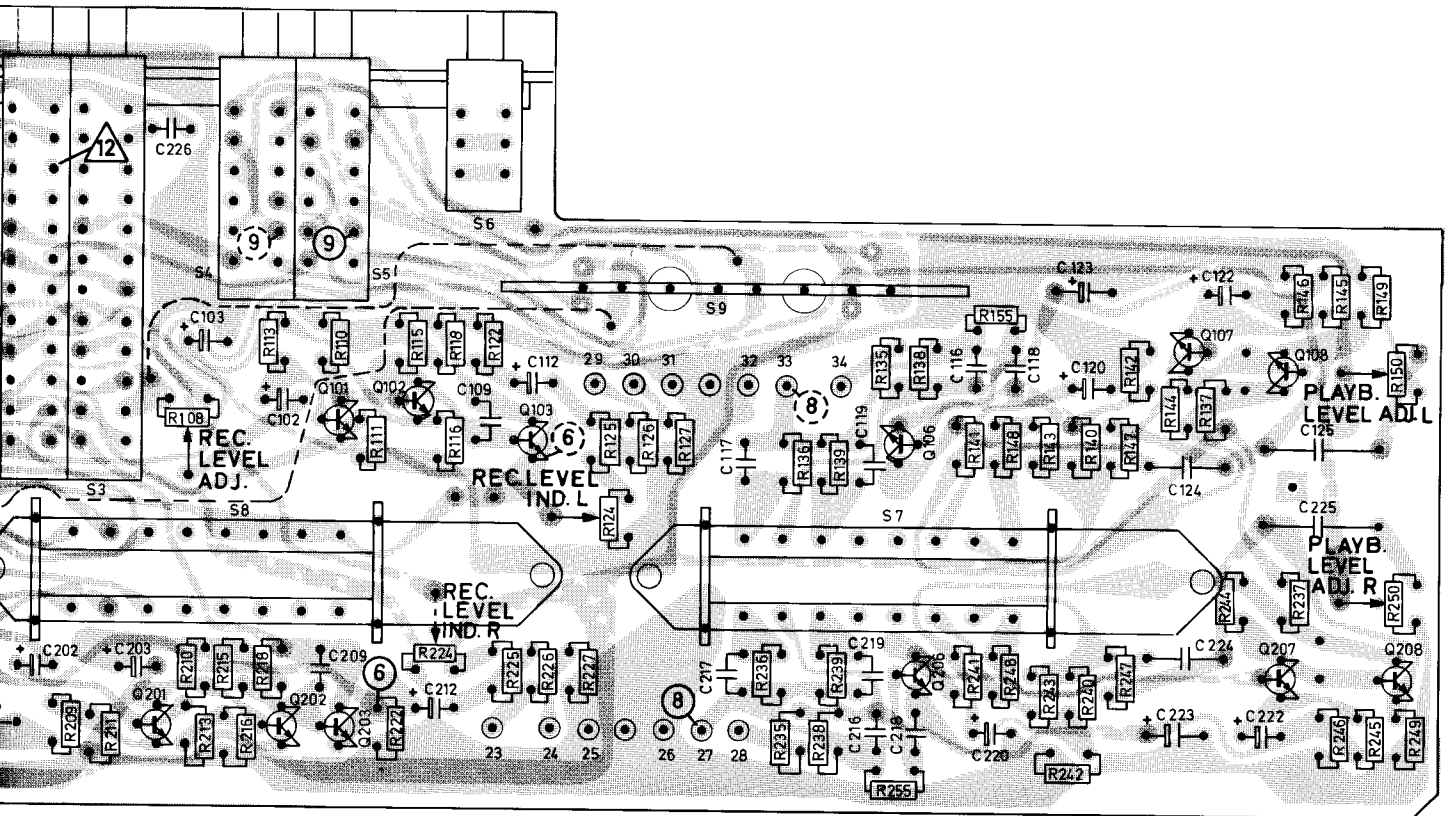

Phono input terminal board, seen from printed side. Board No. 18056 A

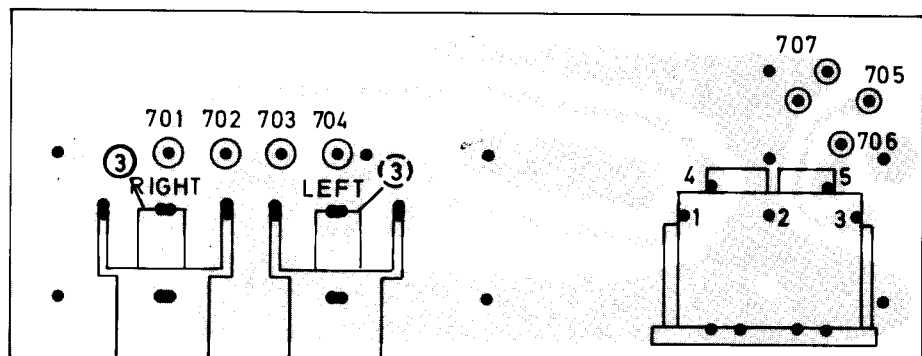

Input terminal board, seen from printed side. Board No. 18056 B

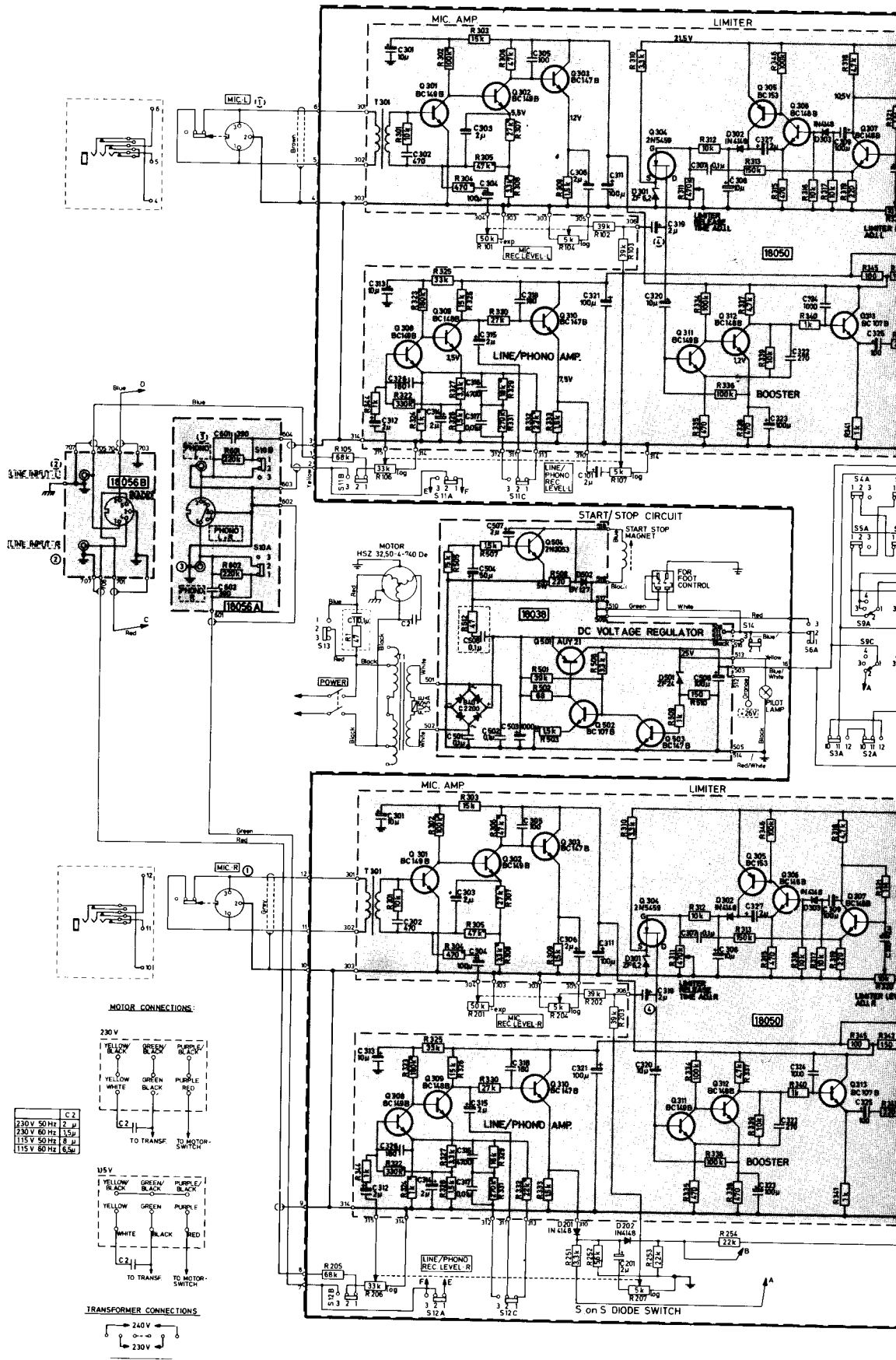

MOTOR CONNECTIONS:

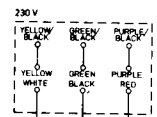

	C2
230 V 50 Hz	2 μ
230 V 60 Hz	1.5 μ
115 V 50 Hz	8 μ
115 V 60 Hz	6.5 μ

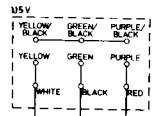

TRANSFORMER CONNECTIONS:

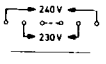

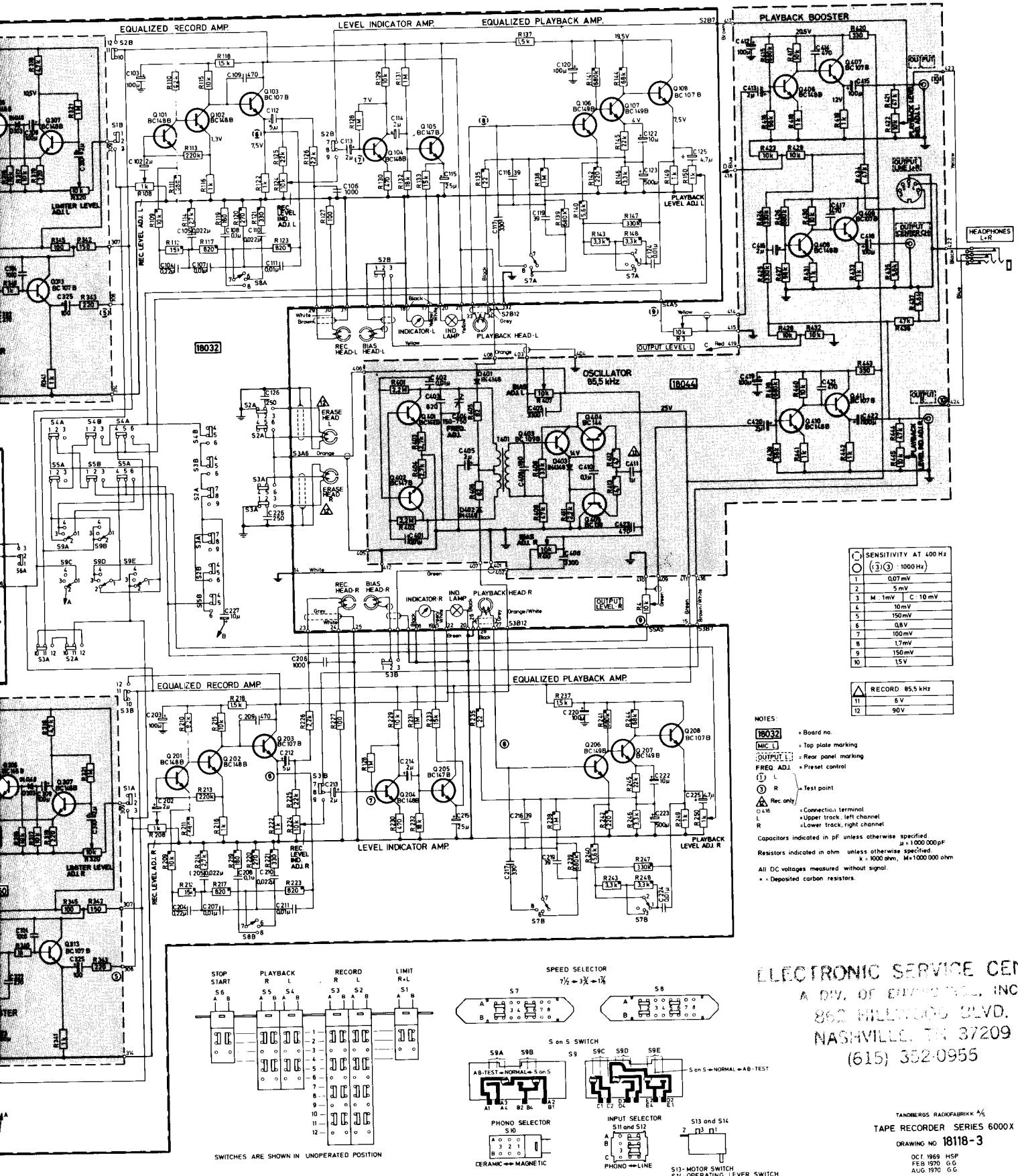

ELECTRONIC SERVICE CENTER
 A DIV. OF ENVIROTEC, INC.
 860 HILLWOOD BLVD.
 NASHVILLE, TN 37209
 (615) 382-0955

TANBERGS RADIOFABRIKK 4/5
TAPE RECORDER SERIES 6000X
 DRAWING NO. 18118-3

OCT 1969 HSP
 FEB 1970 GG
 AUG 1970 GG



Tandbergs Radiofabrikk A/S, Kjelsås.

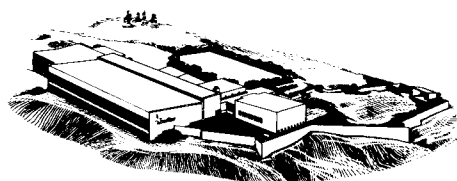

Tandbergs Radiofabrikk A/S, div. Kjeller.

TANDBERGS RADIOFABRIKK A/S

P. O. B. 9, Korsvoll, Oslo 8, Norway