

JULY 1970

Tandberg  
RADIO

**Service manual**

# TANDBERG

**Tape recorder  
series 1600X**

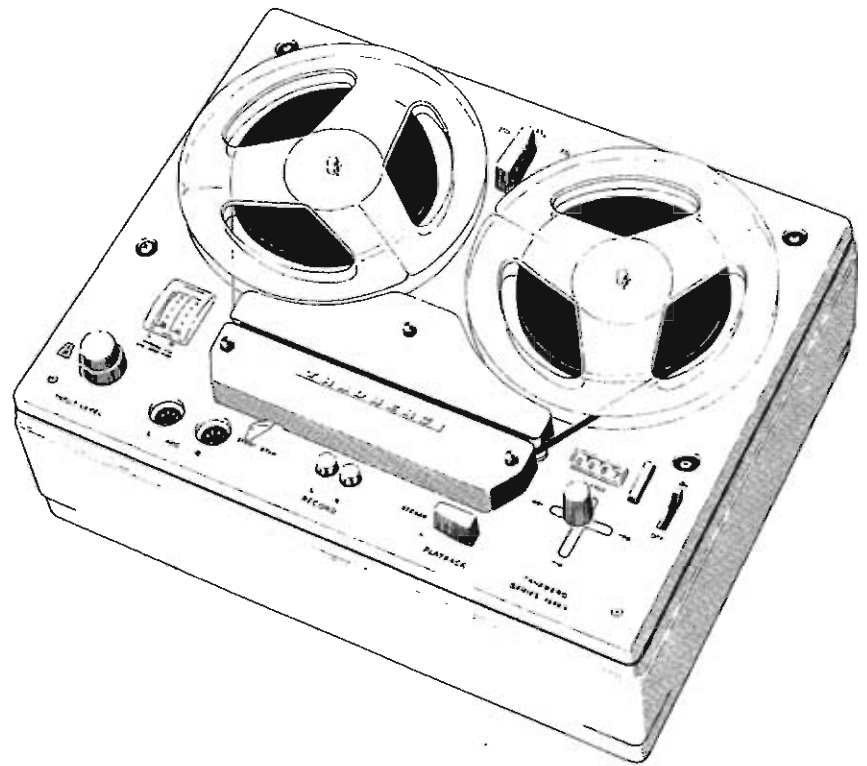

TANDBERGS RADIOFABRIKK A/S

CONTENTS

- 1.0 Technical Specifications ..... 2
- 2.0 Operating Controls..... 4
- 3.0 Input and Output Terminals..... 5
- 4.0 Tape Transport Mechanism. Detailed Description and Alignment Procedures..... 6
  - 4.1 Operating Lever 990225..... 6
    - 4.1.1 Eccentric Segment 990203..... 7
    - 4.1.2 Pressure Roller Arm 990302..... 7
    - 4.1.3 Operating Arm 248186..... 8
  - 4.2 Turntables..... 10
    - 4.2.1 Supply Turntable..... 10
    - 4.2.2 Tape Tension..... 10
    - 4.2.3 Take-up Turntable..... 11
    - 4.2.4 Adjustment of Turntables..... 12
  - 4.3 Clutches..... 13
    - 4.3.1 Neutral..... 13
    - 4.3.2 Normal Forward Drive..... 14
    - 4.3.3 Fast Forward Winding..... 15
    - 4.3.4 Fast Reverse Winding..... 15
    - 4.3.5 Free..... 16
  - 4.4 Motor Pulley 243940C..... 17
  - 4.5 Drive Belt 213997..... 17
  - 4.6 Transfer Wheel 990233..... 18
  - 4.7 Lifting Arm 990201..... 18
  - 4.8 Flywheel with Capstan 990312..... 19
  - 4.9 Speed Selector..... 20
  - 4.10 Instantaneous Start/Stop Mechanism..... 20
  - 4.11 Pressure Pad..... 21
  - 4.12 End Stop Mechanism..... 22
    - 4.12.1 Neutral..... 22
    - 4.12.2 Normal Forward Drive..... 22
    - 4.12.3 Free..... 22
    - 4.12.4 End Stop or Tape Breakage..... 23
    - 4.12.5 Tape Feeler Tension..... 23
- 5.0 Electronic Circuits. Detailed Description..... 24
  - 5.1 The Main Electronic Units. Block Diagram... 24
    - 5.1.1 Microphone and Line Amplifier..... 25
    - 5.1.2 Buffer Amplifier..... 25
    - 5.1.3 Record Equalizing Amplifier..... 25
    - 5.1.4 Indicator Amplifier..... 26
    - 5.1.5 Oscillator with Amplifier. Bias- and Erase Circuits..... 27
  - 5.2 Playback Electronics..... 27
    - 5.2.1 Playback Equalizing Amplifier..... 27
    - 5.2.2 Playback Booster Amplifier..... 28
  - 5.3 Power Supply..... 29
  - 5.4 Output Switching System..... 29
    - 5.4.1 Playback Selector with Output Receptacles..... 29
- 6.0 Alignment of Electrical Circuits and Tape Path... 30
  - 6.1 Head Alignment and Track Control with Tandberg Test Tapes..... 30
    - 6.1.1 Model 1641X (Four Track)..... 30
    - 6.1.2 Demagnetizing..... 30
    - 6.1.3 Tape Guide Adjustment..... 30
    - 6.1.4 Record/Playback Head..... 30
    - 6.1.5 Height Adjustment..... 30
    - 6.1.6 Azimuth Adjustment..... 30
    - 6.1.7 Control of Playback Curves..... 30
    - 6.1.8 Erase Head..... 30
    - 6.1.9 Height Adjustment..... 30
  - 6.2 Model 1621X (Two Track)..... 30
  - 6.3 Head Alignment without Tandberg Test Tapes.. 30
    - 6.3.1 Demagnetizing..... 30
    - 6.3.2 Record/Playback Head..... 30
    - 6.3.3 Height Alignment..... 30
    - 6.3.4 Lateral Alignment..... 31
    - 6.3.5 Azimuth Alignment..... 31
    - 6.3.6 Erase Head..... 31
    - 6.3.7 Height Alignment..... 31
    - 6.3.8 Lateral Alignment..... 31
    - 6.3.9 Azimuth Alignment..... 31
  - 6.4 Track Control, Model 1641X-Four Track, without Tandberg Test Tape..... 31
    - 6.4.1 Record/Playback Head..... 31
    - 6.4.2 Erase Head..... 31
  - 6.5 Track Control, Model 1621X- Two Track, without Tandberg Test Tapes..... 31
    - 6.5.1 Erase Head..... 31
    - 6.5.2 Record/Playback Head..... 32
  - 6.6 Electrical Adjustments for Tandberg Tape Recorder Model 1641X and 1621X..... 32
    - 6.6.1 Adjustment of Output Level..... 32
    - 6.6.2 Adjustment of Oscillator Frequency and Bias..... 32
    - 6.6.3 Using Frequency Meter (Counter)..... 32
    - 6.6.4 Using Signal Generator and Radio Receiver..... 32
    - 6.6.5 Control of Erase Voltage..... 32
    - 6.6.6 Adjustment of Bias..... 32
    - 6.6.7 Preadjustment of Recording Level and Indicator..... 32
    - 6.6.8 Adjustment of Bias Head..... 32
    - 6.6.9 Control of Total Frequency Response... 33
    - 6.6.10 Adjustment of Record Level and Indicator applying Test Tape..... 33
    - 6.6.11 Distortion..... 33
    - 6.6.12 Tape Speed Control..... 33
    - 6.6.13 Control of Playback Curves..... 33
    - 6.6.14 Control of Recording Curves..... 33
  - 6.7 Modifications from Four Track to Two Track Version..... 34
  - 6.8 Connections and Modifications from 115-130-230-240V and from 50 to 60 Hz (or 60 to 50 Hz) Operation..... 34
- 7.0 Spare Parts List..... 35
  - Mechanical Parts..... 35
  - Electrical Components..... 39
  - Lubrication Notes..... 45
  - Set of Special Tools..... 45
  - Circuit Diagrammes and Printed Boards..... 46

# 1.0 TECHNICAL SPECIFICATIONS

**POWER REQUIREMENTS:** Standard Models: 230V, 50 Hz. Convertible to 115 or 240V. U.S. model: 115V, 60 Hz. Convertible to 230V and 240V.

**POWER CONSUMPTION:** 40 W.

**MOTOR:** 2-pole, 230V - 115V, 50 Hz. U.S. model: 115 - 230V, 60 Hz.

**TAPE SPEEDS:** 7 1/2, 3 3/4 and 1 7/8 ips.

**SPEED TOLERANCE:** Absolute tolerance:  $\pm 1.5\%$ .

**PLAYING TIME, Model 1641X:** Four track recording on 1800 ft of tape:

|            | Stereo      | Mono        |
|------------|-------------|-------------|
| 7 1/2 ips: | 2 x 48 min  | 4 x 48 min  |
| 3 3/4 ips: | 2 x 96 min  | 4 x 96 min  |
| 1 7/8 ips: | 2 x 192 min | 4 x 192 min |

**PLAYING TIME, Model 1621X:** Two track recording on 1800 ft of tape:

|            | Stereo  | Mono        |
|------------|---------|-------------|
| 7 1/2 ips: | 48 min  | 2 x 48 min  |
| 3 3/4 ips: | 96 min  | 2 x 96 min  |
| 1 7/8 ips: | 192 min | 2 x 192 min |

**FAST WIND AND REWIND:** Approximately 2 1/4 min for 1800 ft of tape.

**TAPE:** Maximum reel diameter: 7 inch. LOW NOISE TAPE should be used for recording.

**AUTOMATIC STOP:** The automatic stop operates during recording or playback as well as during fast wind and rewind modes.

**HEADS, Model 1641X:** 1 ea four track erase head

1 ea four track record/playback head

1 ea four track crossfield bias head.

**HEADS, Model 1621X:** 1 ea two track erase head

1 ea two track record/playback head

1 ea two track crossfield bias head.

**FREQUENCY RESPONSE:**

|            |                |            |
|------------|----------------|------------|
| 7 1/2 ips: | 40 - 18 000 Hz | $\pm 2$ dB |
| 3 3/4 ips: | 50 - 15 000 Hz | $\pm 2$ dB |
| 1 7/8 ips: | 50 - 9 000 Hz  | $\pm 2$ dB |

Measured according to DIN 45511:

7 1/2 ips: 40 - 20 000 Hz

3 3/4 ips: 40 - 16 000 Hz

1 7/8 ips: 40 - 9 000 Hz

**ERASE AND BIAS FREQUENCY:** 85.5 kHz - distortion less than 0.5%.

**AMPLIFIER DISTORTION:** Record amplifier: 0.5% distortion at 0 dB recording level. Playback amplifier: 0.2% distortion at 0.9V output.

**TAPE DISTORTION:** A 400 Hz signal recorded to 0 dB deflection on the recording meter, gives less than 5% tape distortion in playback.

A 400 Hz signal recorded to -8 dB below 0 dB on the recording meter, gives less than 1% distortion in playback.

**WOW:** Peak value measured in % according to DIN 45507:

7 1/2 ips: Better than 0.1%

3 3/4 ips: Better than 0.2%

1 7/8 ips: Better than 0.4%.

R. M. S.

7 1/2 ips: Better than 0.07%

3 3/4 ips: Better than 0.14%

1 7/8 ips: Better than 0.28%.

CROSSTALK:

Crosstalk at 1 000 Hz according to DIN 45521:

|         |                    |
|---------|--------------------|
| Mono:   | Better than 60 dB  |
| Stereo: | Better than 50 dB. |

INPUTS:

Each channel has the following inputs:

1. Microphone Input for low impedance dynamic microphone. Impedance: 200 ohm, unbalanced. Sensitivity: 0.1 mV at 400 Hz. Maximum input level: 30 mV. 5-pin DIN receptacle.
2. Line input (HIGH IN) for high impedance connection. Impedance: 1 Mohm. Sensitivity: 100 mV at 400 Hz. Maximum input level: 20V. Phono receptacle.
3. Line input (LOW IN) for low impedance connection. Impedance: 57 kohm. Sensitivity: 5 mV at 400 Hz. Maximum input level: 1V. Phono receptacle. Pins 1 and 4 on the DIN receptacle (RADIO) are connected in parallel with phono receptacles LOW IN LEFT and RIGHT respectively.

OUTPUTS:

Emitter follower outputs. Minimum impedance: 200 ohm. Output level: A tape recorded with 400 Hz to 0 dB deflection on the recording meter, will at playback give 0.9V output. Phono receptacles.

Pins 3 and 5 on the DIN receptacle (RADIO) are connected in parallel with the phono receptacles OUTPUT LEFT and RIGHT respectively.

SIGNAL NOISE:

R. M. S. Unweighted:

|            |           |
|------------|-----------|
| Four Track | Two Track |
| 55 dB      | 55 dB     |

SIGNAL/TAPE NOISE:

Measured according to IEC standard (A-curve) R. M. S. :

|            |           |
|------------|-----------|
| Four Track | Two Track |
| 60 dB      | 62 dB     |

SIGNAL/NOISE:

Peak value measured according to DIN 45405 (Geräuschspannung) at tape speed 7 1/2 ips and 5% distortion:

|            |           |
|------------|-----------|
| Four Track | Two Track |
| 53 dB      | 55 dB     |

SIGNAL/HUM:

Peak value measured according to DIN 45405 (Fremdspannung) at tape speed 7 1/2 ips and 5% distortion:

|            |           |
|------------|-----------|
| Four Track | Two Track |
| 50 dB      | 50 dB     |

TRANSISTORS AND DIODES:

10 ea BC 149B, 8 ea BC 147B, 8 ea BC 148B, 7 ea BC 107B, 1 ea BC 144, 1 ea BC 139, 1 ea AUY 21, 3 ea IN 4148, 1 ea ZF 27.

RECTIFIER:

B40 C2200.

DIMENSIONS:

Length: 15 3/8" (39 cm), height: 6 11/16" (17 cm), depth: 11 13/16" (30 cm).

WEIGHT:

19 lbs 20 oz. (8.7 kg).

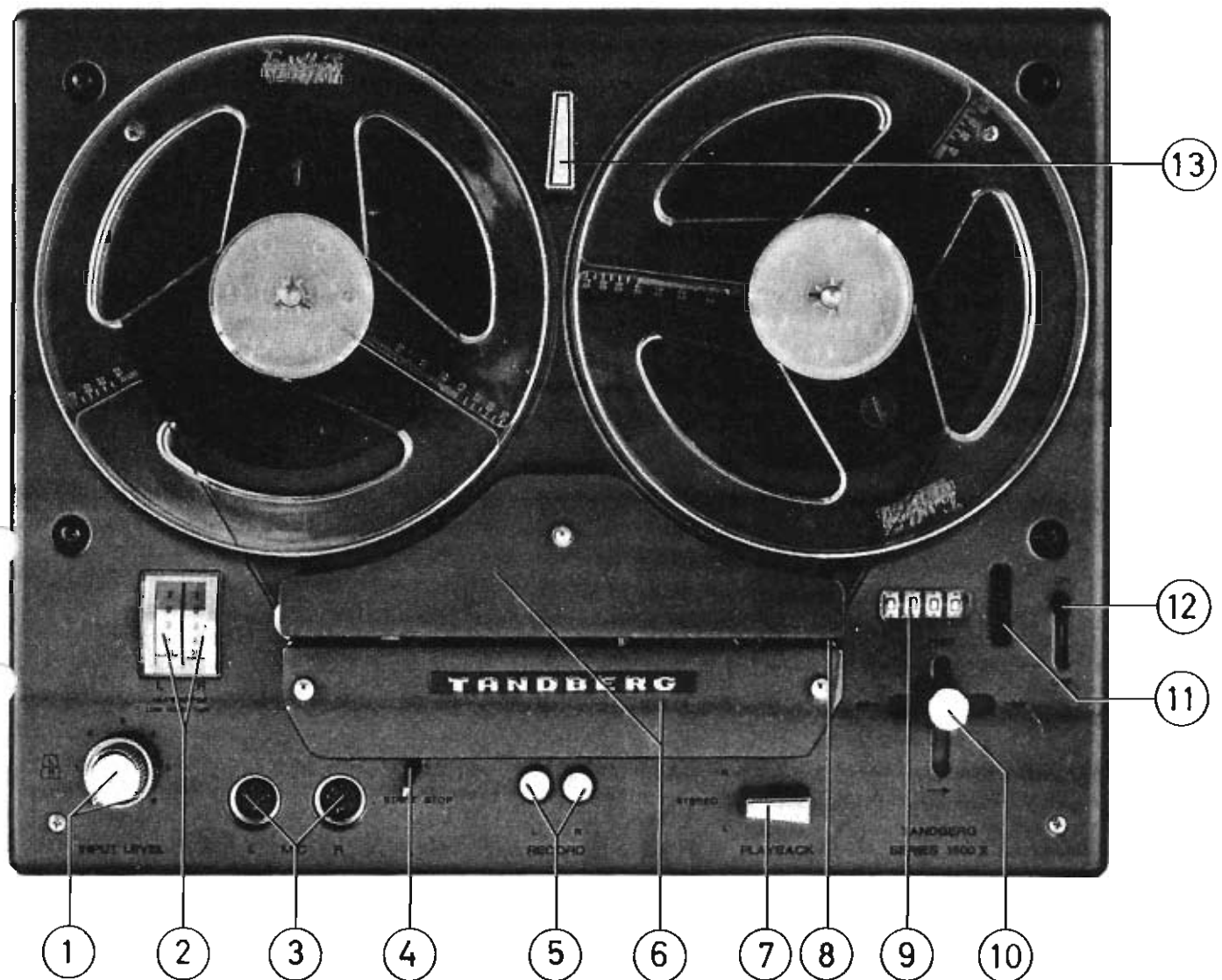

Fig. 2.0 Operating controls

## 2.0 OPERATING CONTROLS

- |                                |   |
|--------------------------------|---|
| 1. INPUT LEVEL CONTROLS:       | Adjust the recording level of both channels, separately or simultaneously.<br>Upper knob: Programme from L input sockets.<br>Lower knob: Programme from R input sockets.  |
| 2. RECORD LEVEL INDICATORS:    | Correct recording level corresponds to an indicator reading just below the area.<br>Left indicator: L channel.<br>Right indicator: R channel.   |
| 3. MICROPHONE SOCKETS:         | Low impedance microphone inputs. Impedance: 200 ohm, unbalanced. Maximum input level: 30 mV.  |
| 4. INSTANTANEOUS START/STOP:   | Starts and stops the tape instantaneously in record and playback modes.   |
| 5. RECORD BUTTONS:             | Activate the electronic circuits for recording when they are depressed. In raised position, the electronic circuits for playback are activated. An interlock system is introduced between the record buttons and the operating lever to prevent undesired erasure.<br>RECORD L: Left channel.<br>RECORD R: Right channel. |
| 6. FRONT AND REAR HEAD COVERS: | Remove for cleaning of heads and tape path.   |
| 7. OUTPUT SELECTOR:            | L position: Programme from L channel is reproduced through L and R outputs.<br>R position: Programme from R channel is reproduced through L and R outputs.<br>Stereo position: Programmes from L and R channels are fed to their respective outputs.  |

8. AUTOMATIC END STOP: Shuts off the motor when the tape runs out or if the tape breaks.
9. TAPE COUNTER: 4 digit counter which indicates the tape position.
10. OPERATING LEVER: Activates the mechanism in the tape recorder for the different modes of operation:  
 ← : Fast rewind. → : Fast forward wind. → : Normal forward drive for recording or playback.
11. RESET BUTTON: Resets the tape counter to zero.
12. POWER SWITCH: Switches the mains on and off.
13. TAPE SPEED SELECTOR: For selection of tape speeds: 1 7/8, 3 3/4 and 7 1/2 ips.

### 3.0 INPUT AND OUTPUT TERMINALS

#### MICROPHONE sockets

Model 1600X is available with two different types of microphone sockets.

The European version is furnished with DIN-sockets, ref. fig. 3.0.

The U.S. version is furnished with standard telephone jacks, ref. fig. 3.1.

Both versions have the same specifications: Impedance: 200 ohm, unbalanced. Maximum input level: 30 mV. Sensitivity: 0.1 mV at 400 Hz.

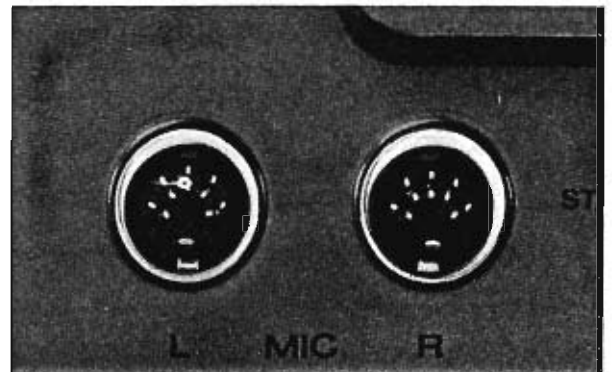

Fig. 3.0 Microphone Inputs, European version

#### RADIO DIN-socket

This socket is a combined input and output socket. Pins 1 and 4 are connected in parallel with inputs LOW IN LEFT and RIGHT respectively. Pins 3 and 5 are connected in parallel with outputs OUTPUT LEFT and RIGHT respectively. Technical specifications same as the parallel connectors.

#### +26V special connector

Outlet for operating voltage (+26V) to Tandberg FM-multiplex filter.

#### HIGH IN sockets

Phono-sockets for high impedance connection. Impedance: 1 Mohm. Maximum input level: 20V.

#### LOW IN sockets

Phono-sockets for low impedance connection. Impedance: 57 kohm. Maximum input level: 1V. LOW IN LEFT and RIGHT are respectively connected in parallel with pins 1 and 4 on DIN-socket RADIO.

#### OUTPUT sockets

Phono-sockets for connection of minimum load impedance: 200 ohm. Pin 3 and 5 on RADIO socket are connected in parallel with OUTPUT LEFT and RIGHT, respectively.



Fig. 3.1 Microphone inputs, US version

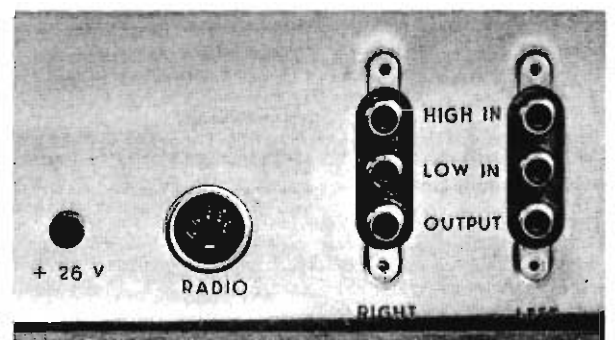

Fig. 3.2 Input and output sockets, rear panel

# 4.0 TAPE TRANSPORT MECHANISM

## Detailed Description and Alignment Procedures

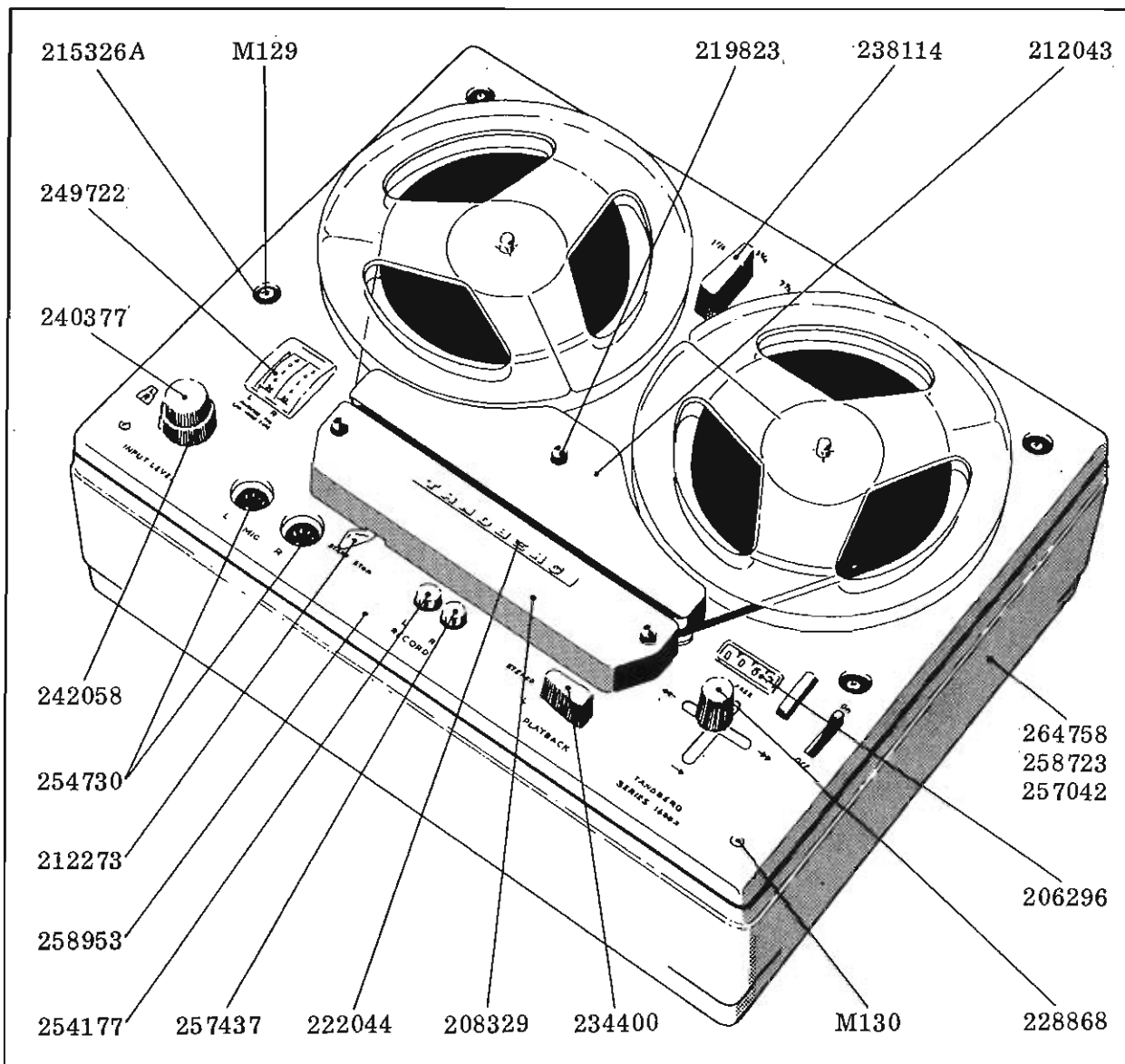

Fig. 4.1 Set of knobs

The purpose of the tape transport mechanism is to accomplish the tape motion for the following modes of operation:

1. Normal forward drive.
2. Fast forward winding.
3. Fast reverse winding.

These modes can be selected by the tape motion lever.

### 4.1 OPERATING LEVER 990225

The operating lever is situated in front of the counter, and is attached to lower mounting plate. The lever can be set to the following five positions:

1. Neutral.
2. Normal forward drive.
3. Fast forward winding.
4. Fast reverse winding.
5. Free.

Parts associated with the tape motion lever:

The eccentric segment 990203, which operates pressure roller arm 990302, and lifting arm 990201. Operating arm 248186 operates clutch levers 990229 and 990228, underneath friction disc 990236.

### 4.1.1 Eccentric Segment 990203

The eccentric segment is situated underneath upper mounting plate, and is linked with operating lever shaft 990225. The eccentric segment moves pressure roller arm 990302 with roller 990234 against the capstan when the operating lever is set to position normal forward drive.

Lifting arm 990201 is linked with eccentric segment 990203 and engages transfer wheel 990233 with motor pulley 243940C when the operating lever is set to position normal forward drive only.

#### Adjustment

Set operating lever in neutral position, and adjust the resting position of the pressure roller assembly by bending bracket A. See fig. 4.2.

Be careful not to destroy the rubber sleeve which is threaded on the flap. Take it off, or grip with the plier underneath the rubber. The flap is in correct position when the pressure roller arm rests in its hindmost position, and the eccentric segment lightly touches plastic roller 207977.

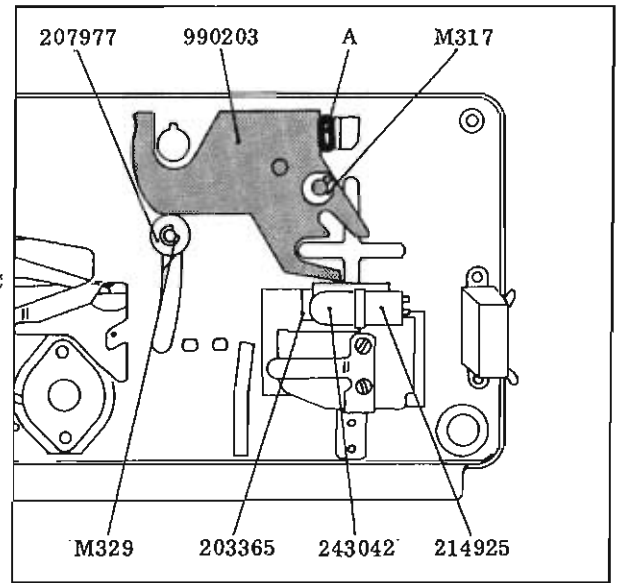

Fig. 4.2 Upper mounting plate. View from underneath

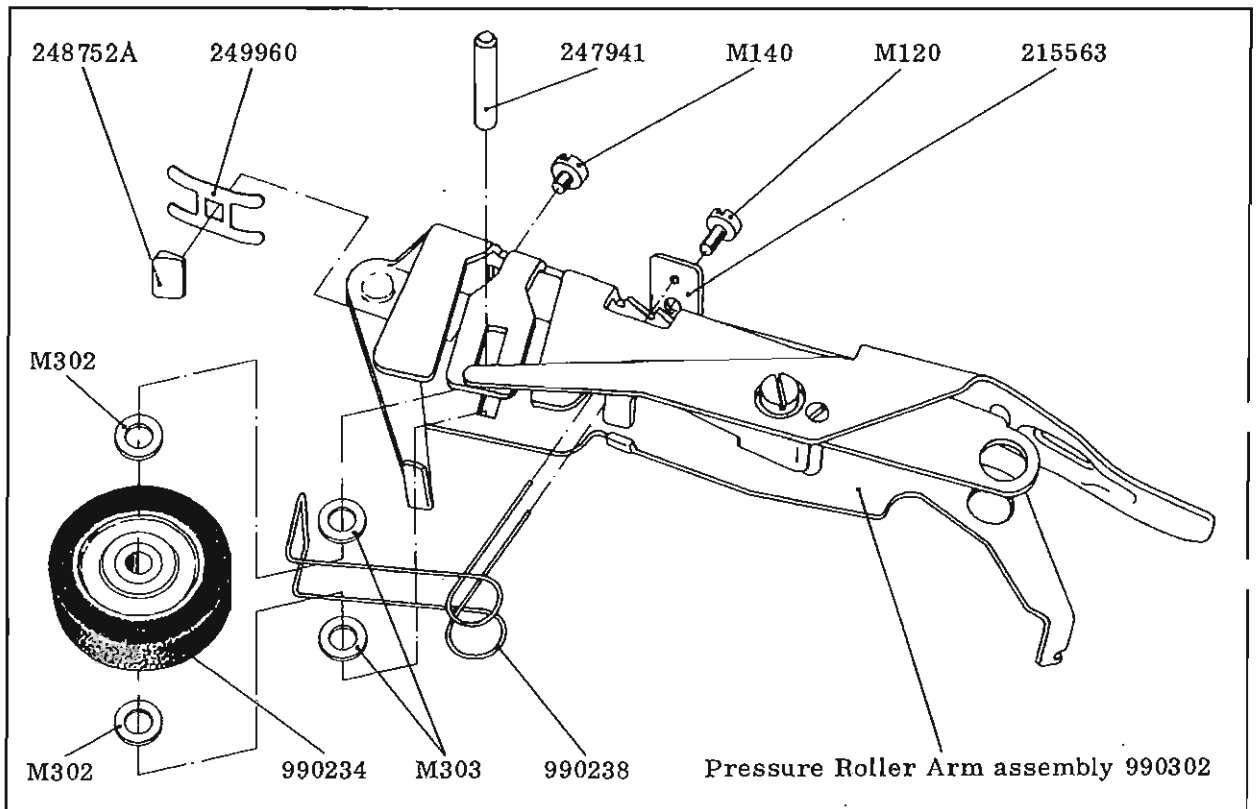

Fig. 4.3 Pressure roller arm assembly

### 4.1.2 Pressure Roller Arm 990302

The pressure roller assembly is moved against the capstan by eccentric segment 990203 when operating lever 990225 is set to position normal forward drive. Pressure

roller 990234 is suspended under balanced spring tension as shown in fig. 4.3.

For adjustments, please turn over:



### Adjustment

The balanced spring tension is adjusted to ensure that the pressure from the pressure roller against the capstan and the tape is evenly distributed across the width of the tape in normal forward drive.

Start the tape reorder in normal forward drive. Twist latch 215563 clockwise or counterclockwise after first having loosened screw M120, until the tape moves smoothly over the pressure roller. No air bubbles must

be formed between the tape and the rubber pressure ring on the pressure roller.

Ensure that the entire width of the tape is covered by the roller.

When the instantaneous start/stop handle is operated to STOP position, the pressure roller will be prevented from turning by means of plastic part 248752A which is pressed against the rubber surface by spring 249960. If it is still possible to turn the pressure roller by a lightly touch of a finger, adjust screw B until the roller is immovable.

### 1.1.3 Operating Arm 248186

The operating arm is attached to lower mounting plate and operates clutch levers 990229 and 990228 underneath friction discs 990236. See fig. 4.5. The operating arm is linked with operating lever 990225.

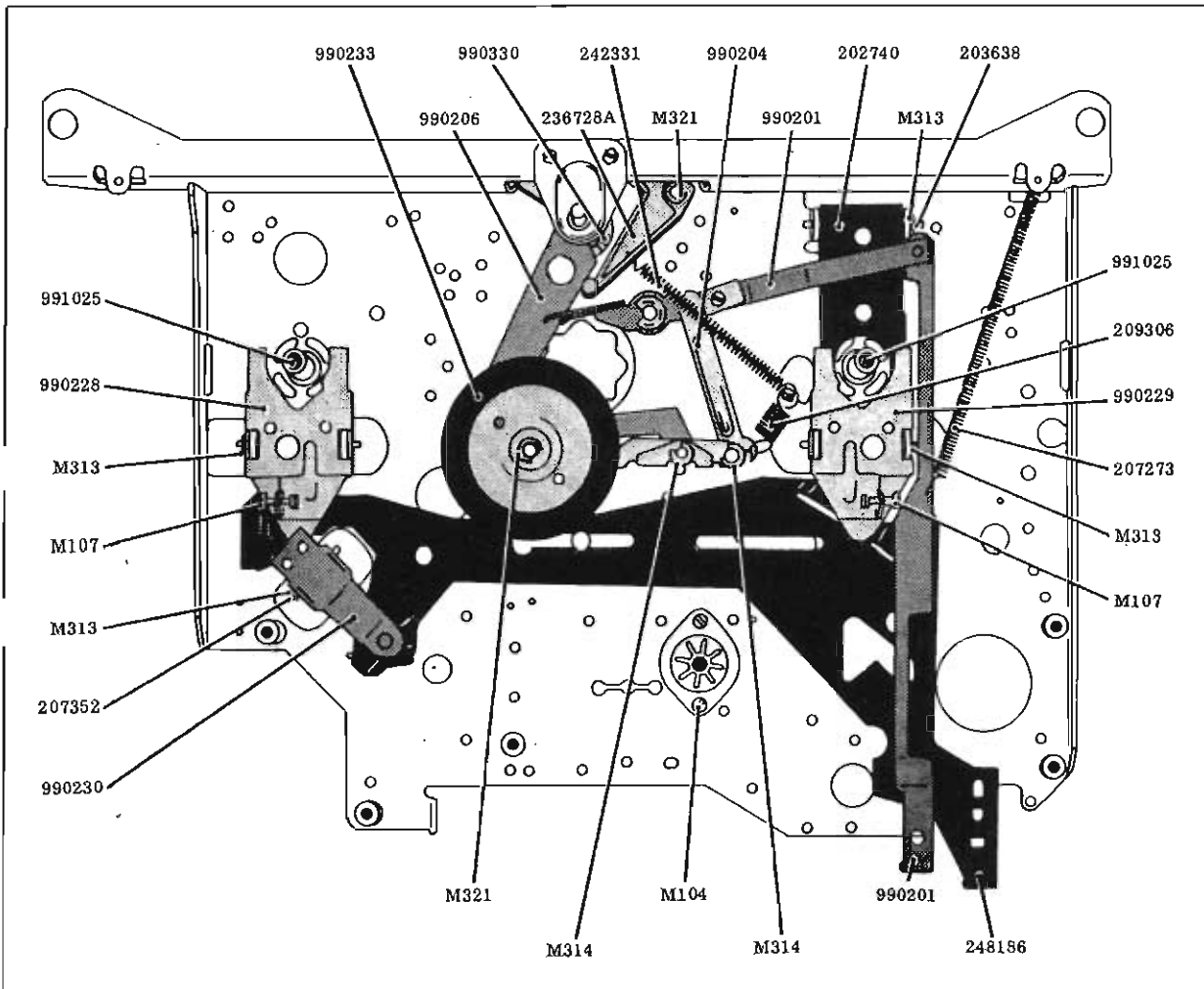

Fig. 4.5 Lower mounting plate

1650X

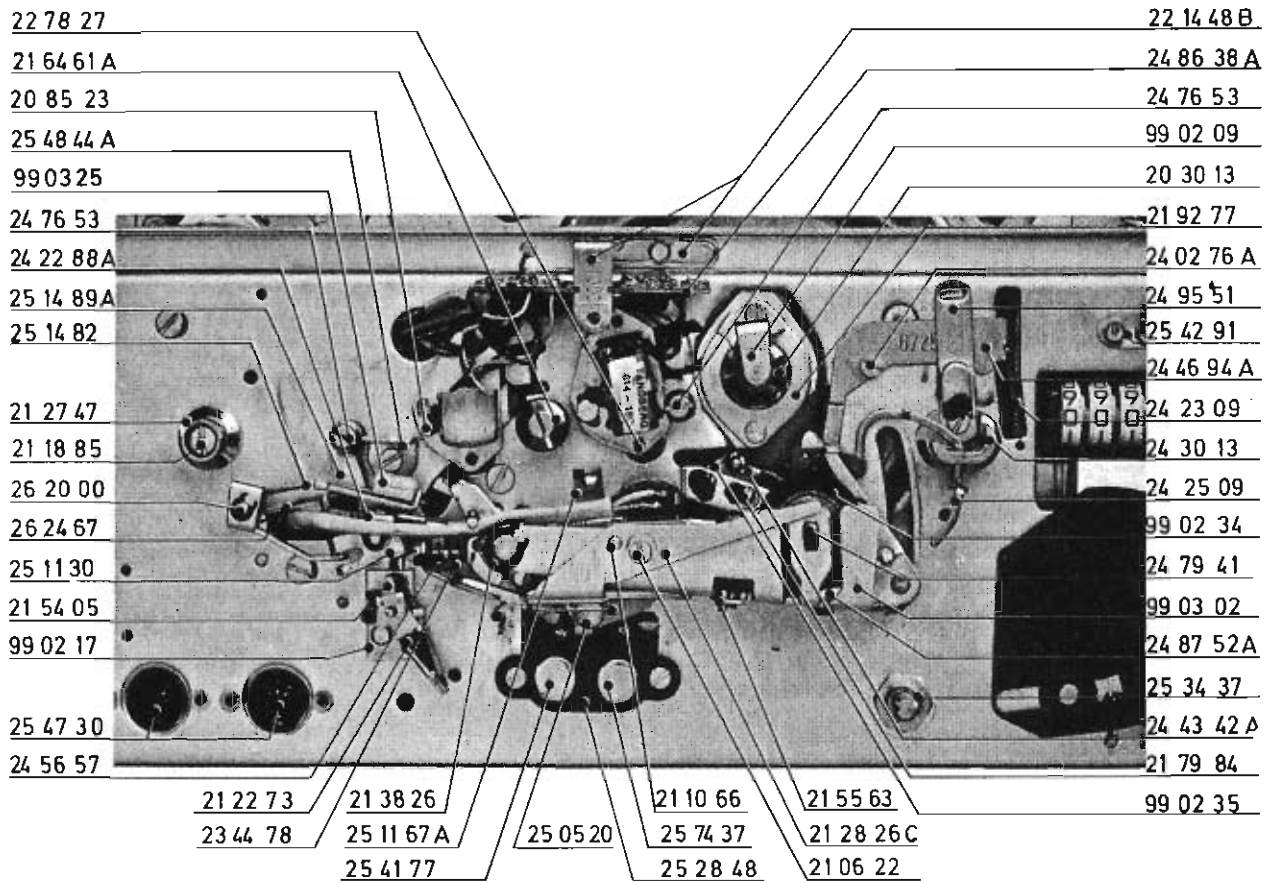

Fig. 4.4 Tape path

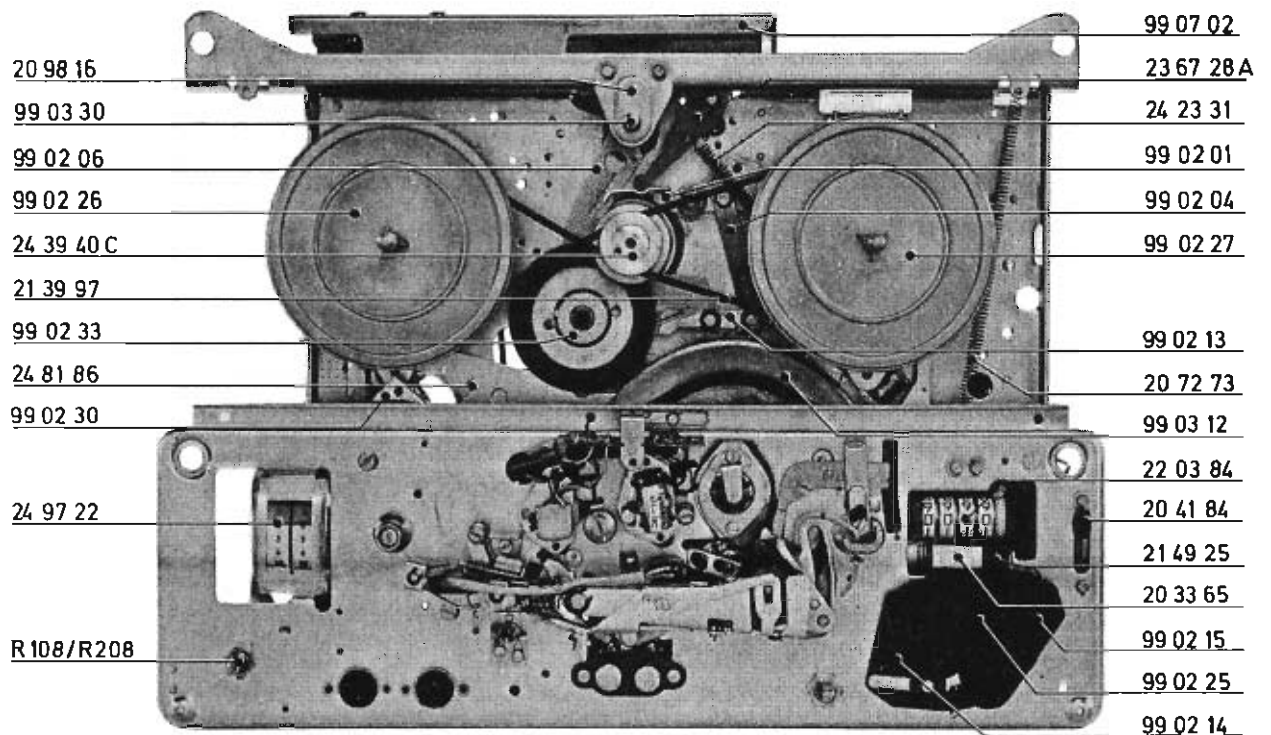

Fig. 4.5a Mechanism of tape recorder. Top view

## 4.2 TURNTABLES

Figures 4.9 and 4.6 show the take-up turntable assembly 990227 and supply turntable assembly 990226 with friction discs 990236 and clutch levers 990229 and 990228.

### 4.2.1 Supply Turntable

See fig. 4.6. The supply turntable and the friction coupling are assembled as follows:

Place helical spring 218415 and friction disc 990236 over the bearing housing 991025 with one end of the spring resting in the cylindrical groove of the friction disc. The delrin tongue on the disc should point at the front of the recorder. Push the friction disc down, ensuring that the lugs on the disc pass between the fingers of clutch lever 990228. Then turn the disc 90° clockwise until the tongue fits into the notch on the lever shown in fig. 4.7. The disc is now locked in this position. Put on mylar sheet 215743. Press flange 219816 down through the upper part of the housing.

Insert the two springs 217510 into the circular recesses in the friction disc. Then place tape tightening disc 219198 on top with its smaller guide pins extending into the springs. Put the turntable shaft through the bearing housing. Set operating lever 990225 in position fast forward winding. The friction wheel is thereby pressed down by the lever and the turntable rests on tape tightening disc 219198. Put teflon washer M355 down on the turntable shaft before the hexagonal delrin bushing 218767 is screwed on. The turntable should now move freely, and the axial slack of the turntable should be approx. 0.1 mm (4 mil).

### 4.2.2 Tape Tensioner

When the instantaneous start/stop lever is in normal forward drive with a full 7" reel on the supply turntable, there might be a tendency to forming of tape loops between the supply reel and the head covers. In order to avoid this, a slight braking torque is applied on the supply turntable.

### Adjustment

Adjustment is accomplished by stretching or cutting the two springs 217510 until the braking torque is sufficient to prevent forming of loops during normal forward drive and when the tape is stopped with the instantaneous start/stop lever. Use a full 7" reel on the supply turntable. Be careful not to stretch the springs too much, as this may cause unevenly forward movement of the tape and consequently wow or flutter in the recorded program.

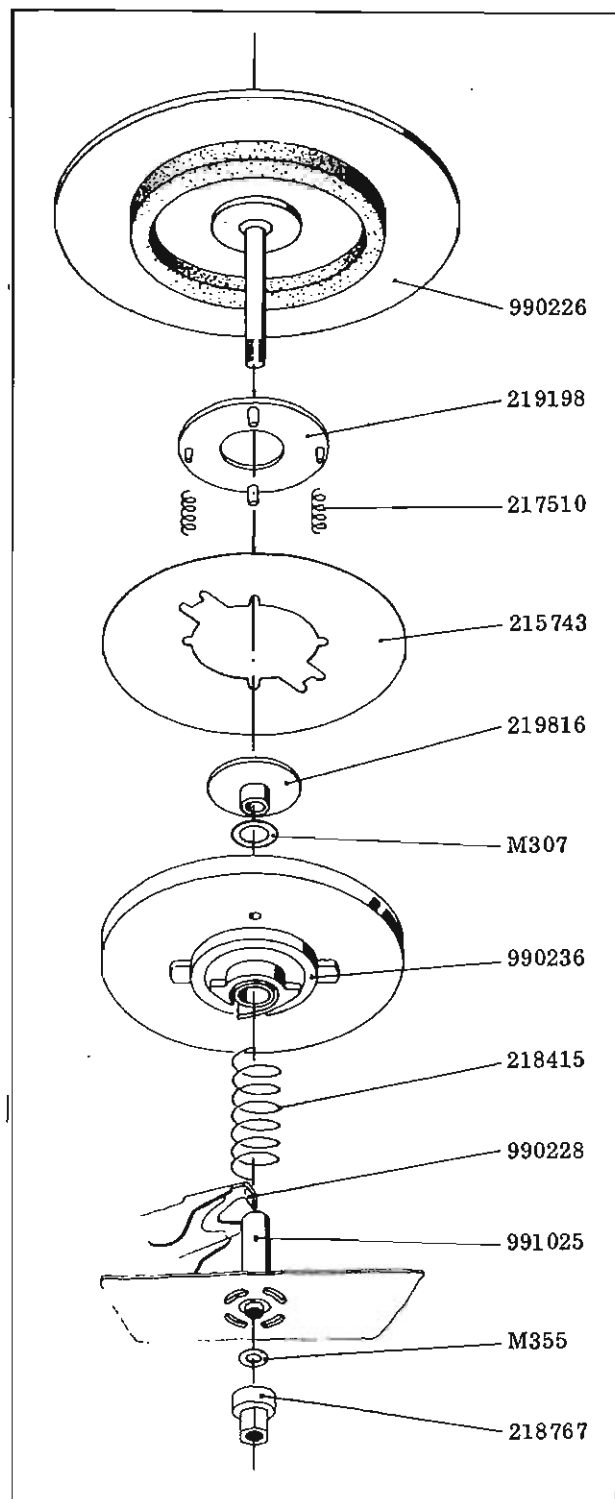

Fig. 4.6 Supply turntable

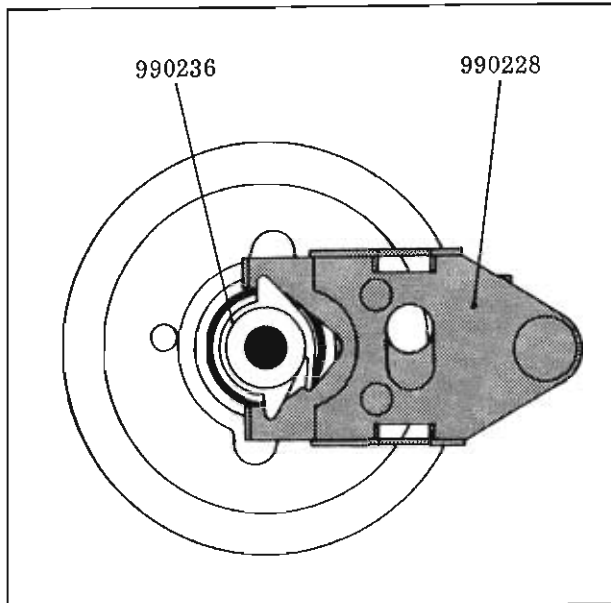

Fig. 4.7 Left friction disc w/lever

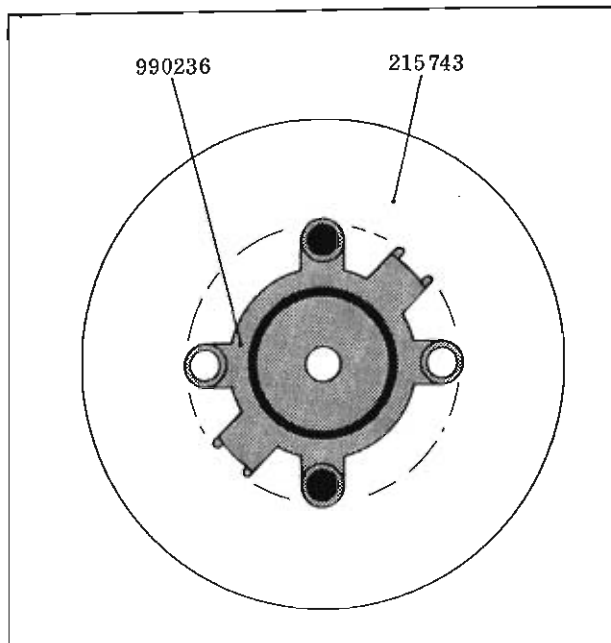

Fig. 4.8 Mylar sheet

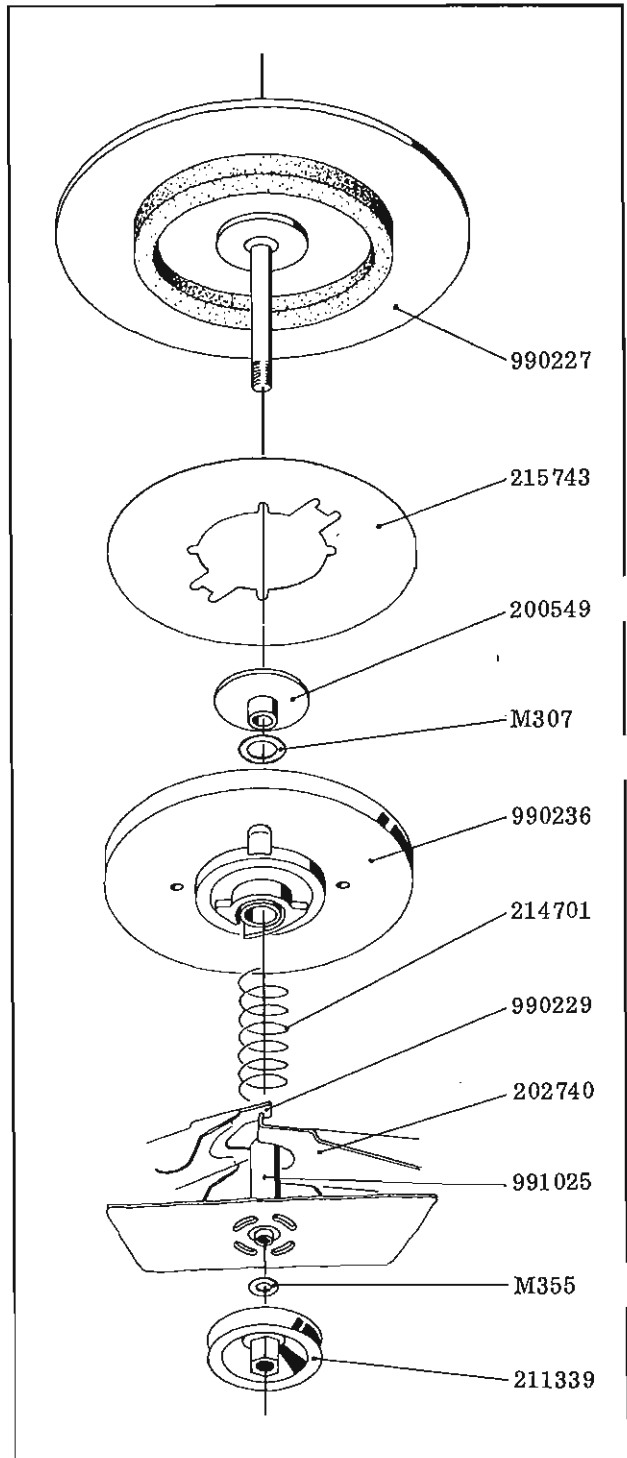

Fig. 4.9 Take-up turntable

### 4.2.3 Take-Up Turntable

See fig. 4.9. The take-up turntable assembly is put together as follows:

Place helical spring 214701 and friction disc 990236 over bearing housing 991025 with one end of the spring resting in the cylindrical groove of the friction disc. The delrin tongue on the disc should point at the rear of the tape recorder. Push friction disc 990236 down, with the delrin studs on the disc passing through the notch in upper clutch lever 990229. Press lower clutch lever 202740 against lower mounting plate by means of a screw driver. The spacing

1600x

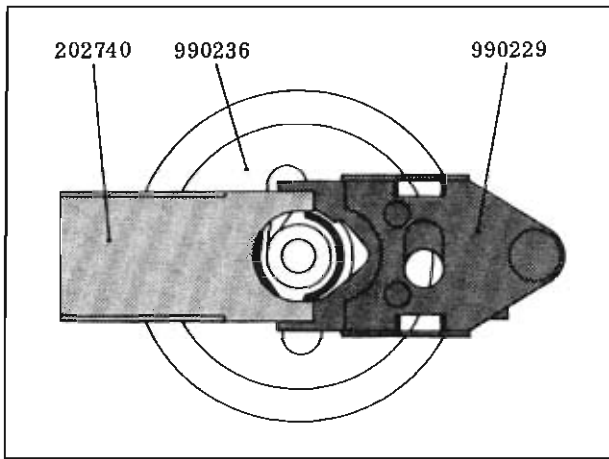

Fig. 4.10 Right friction disc

between upper and lower levers will now be approx. 6 mm (1/4"). Turn the disc 90° counterclockwise until the two delrin studs are locked by the two claws on the lower clutch lever.

Put on mylar washer 215743, press flange 200549 down into the upper end of the housing and insert the turntable shaft through the housing. Move operating lever 990225 to position fast reverse winding, whereby the friction disc is pressed down by the upper clutch lever causing the turntable to rest on the flange. Put teflon washer M355 on the turntable shaft and fasten counter pulley 211339. The turntable should now move freely with an axial slack of approx. 0.1 mm (4 mil).

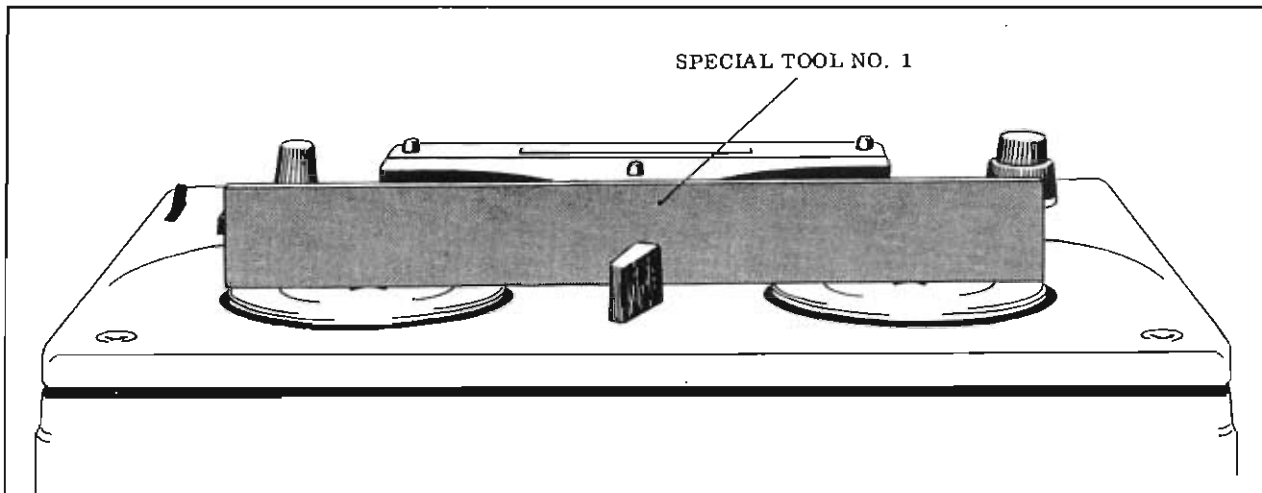

Fig. 4.11 Horizontal adjustment of turntables

#### 4.2.4 Adjustment of Turntables

Use special tools no. 1, 2 and 3. See fig. at the rear of the manual.

##### Horizontal Adjustment

See fig. 4.11. Check the horizontal position of the turntable with reference to a line parallel to the front of the tape recorder by means of special tool no. 1 placed on both turntables. There should be no spacing between the tool and the ribs on the turntables.

Check the horizontal position of the turntables along a line perpendicular to the front of the tape recorder by placing special tool no. 2 on supply turntable and take-up turntable respectively as shown in fig. 4.12. The end of the tool should pass freely through the slot in the tape guide post when the operating lever is in neutral position. Adjustment of the turntable bearing is in both cases performed with special tool no. 3 which is put down on the center pin of the turntable. In order not to risk any bending of the turntable shaft, grip the tool just above the turntable. See fig. 4.13.

##### Height Adjustment

When the horizontal adjustment has been performed, the vertical position of the turntable is checked with 7" reels on both turntables, and the tape correctly inserted in the tape path. Check that the tape runs freely between the flanges of the reels in all positions of the operating lever. The turntables can be raised or lowered by adding or removing turbax washers type M307 between flange 200549 and housing 991025, see fig. 4.6 and 4.9. Recheck the horizontal position of both turntables.

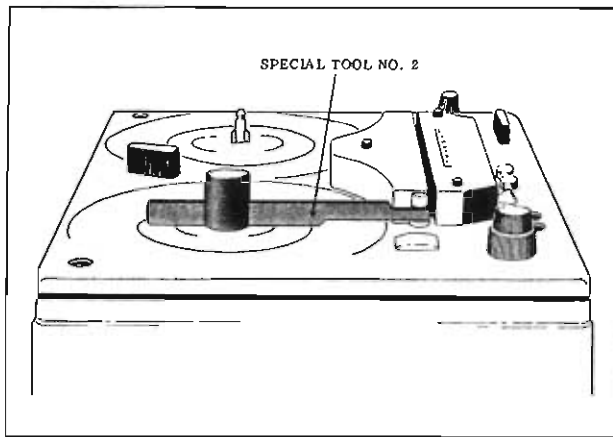

Fig. 4.12 Control of turntables

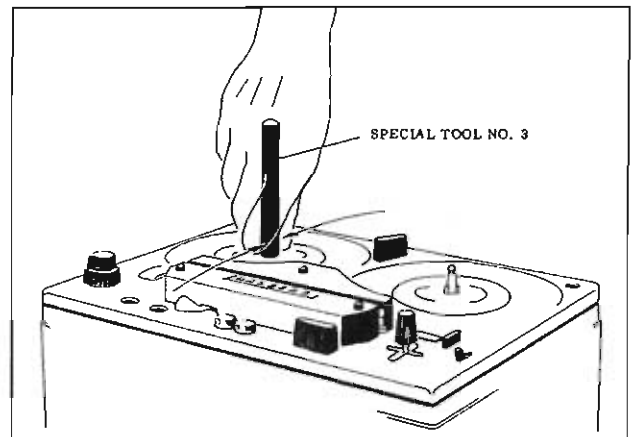

Fig. 4.13 Adjustment

### 4.3 CLUTCHES

The motor torque is transferred to the turntables by means of the friction discs and the felt ring which is glued on to the bottom side of the turntables. The amount

of friction is determined by the clutches which are operated by operating arm 248186. The operating arm is linked with operating lever 990225.

#### 4.3.1 Neutral

The motor current is switched off by switch 202151 and both friction discs 990236 are stationary.

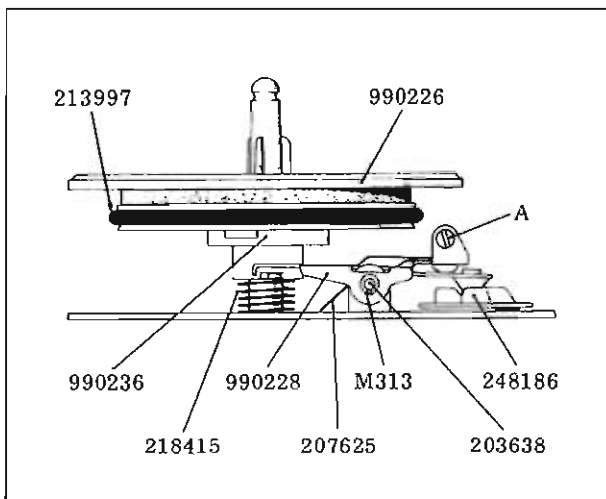

Fig. 4.14 Supply Turntable

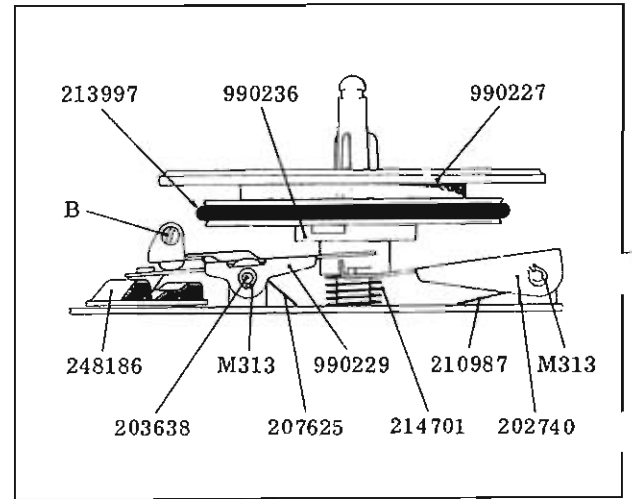

Fig. 4.15 Take-up turntable

#### Supply Turntable 990226

In neutral position the friction between the turntable and friction disc 990236 is at maximum. The friction disc is pressed against the felt ring underneath the turntable by spring 214701, and by the spring loaded lower clutch lever by spring 218415. Operating arm 248186 is in a position that allows the delrin knob on lever 990228 to rest in lower position. The delrin studs on the friction disc are disengaged from the clutch lever.

#### Take-Up Turntable 990227

When the operating lever is in neutral position, maximum friction exists between friction discs 990236 and the take-up turntable. The friction disc is pressed against the felt ring underneath the turntable by spring 214701, and by the spring loaded lower clutch lever 202740 which exerts pressure against the friction disc from underneath. Operating arm 248186 is in a position so as to leave the delrin knob on upper clutch lever 990229 in lower position.

### Adjustment

Adjust screw A until the spacing between the lever and delrin studs on the bushing is 0.5 - 1 mm (20 - 40 mil). Check the lever position in all operating modes and seal screw A.

### Adjustment

Adjust screw B until the spacing between upper and lower clutch levers is approx. 0.5 mm (20 mil). Check the lever positions in all operating modes and seal screw B.

## 4.3.2 Normal Forward Drive

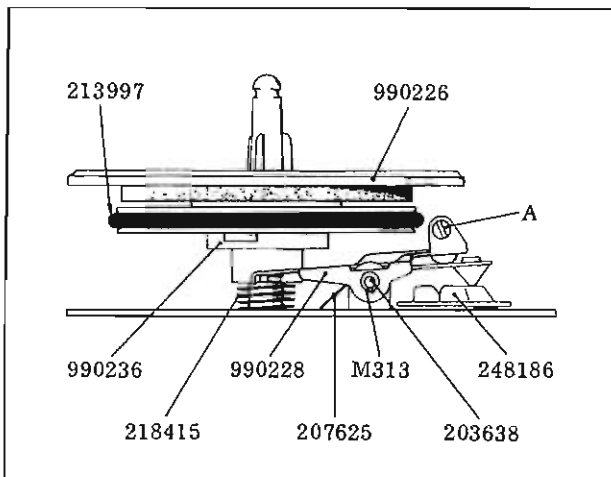

Fig. 4.16 Supply turntable

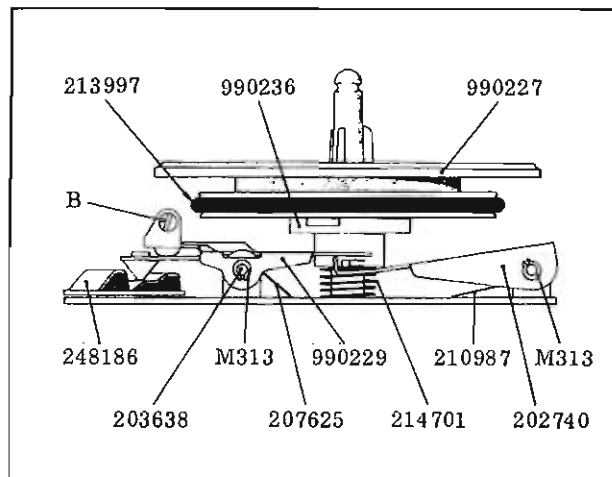

Fig. 4.17 Take-up turntable

### Supply Turntable

The supply turntable is released in normal forward drive mode. The delrin knob on clutch lever 990228 is held in upper position by operating lever 248186. Friction disc 990236 is pressed down.

### Take-Up Turntable

In normal forward drive the take-up turntable has a winding torque which is just sufficient to wind the tape in record and playback mode. The operating arm holds the delrin knob on the lever in an intermediate position. Upper clutch lever 990229 will press down lower clutch lever 202740 thereby releasing the pressure of the friction disc against the turntable. The friction disc is pressed against the turntable felt ring by spring 214701.

### Adjustment

Adjust screw A until the spacing between the friction disc and the felt ring underneath the turntable is between 0.5 and 1.0 mm (20-40 mil). Check the clutch lever positions in all operating modes, and seal screw A.

### Adjustment

By means of screw B, bring the two delrin studs on the friction disc to a position half-way between upper and lower clutch levers. The winding torque should amount to 120 - 200 g cm (1.7 - 2.8 oz in). Check the position of the levers in all position of the operating lever and seal screw B.

### 4.3.3 Fast Forward Winding

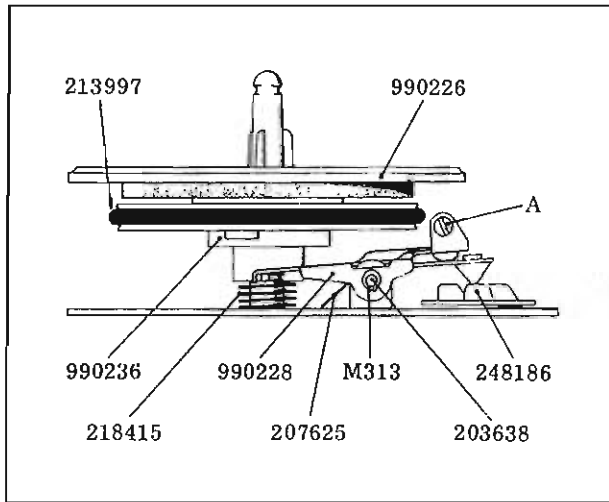

Fig. 4.18 Supply turntable

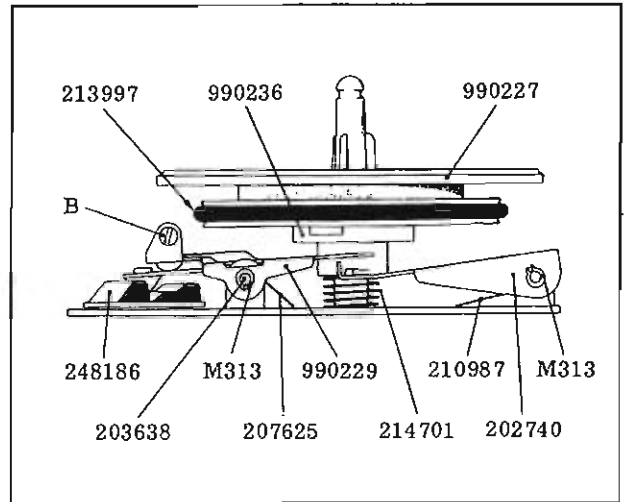

Fig. 4.19 Take-up turntable

#### Supply Turntable

This turntable is released in fast forward winding. The delrin knob on clutch lever 990228 is held in its uppermost position by operating arm 248186, and depresses friction disc 990236.

#### Take-Up Turntable

This turntable has maximum torque in fast forward winding. The operating arm is in a position that allows the delrin knob on upper clutch lever 990229 to rest in its bottom position. Upper and lower clutch levers are disengaged. The friction disc is pressed against the felt ring underneath the turntable by spring 214701 and the spring loaded clutch lever is pressed against the delrin bushing on the friction disc.

#### Adjustment

By means of screw A, adjust the clearance between the friction disc and the felt ring on the turntable to 0.5 - 1 mm (20 - 40 mil). Check the position of the clutch lever in all operating modes, and seal screw A.

#### Adjustment

By means of screw B, adjust the clearance between upper and lower levers to approx. 0.5 mm (20 mil). The winding torque should amount to minimum 520 g cm (7.2 oz. in.). Check the position of the clutch levers for all positions of the operating lever and seal screw B.

### 4.3.4 Fast Reverse Winding

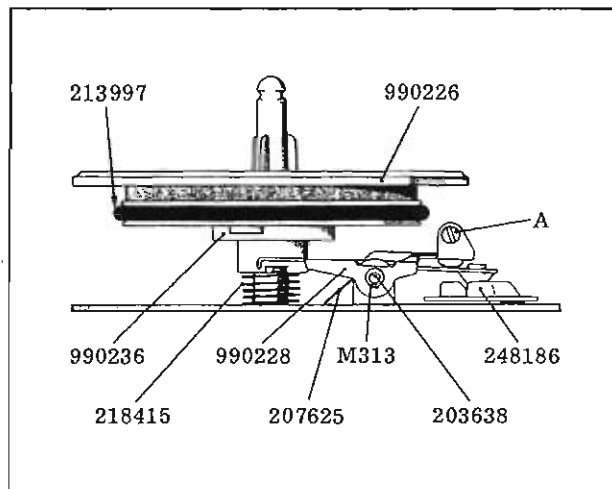

Fig. 4.20 Supply turntable

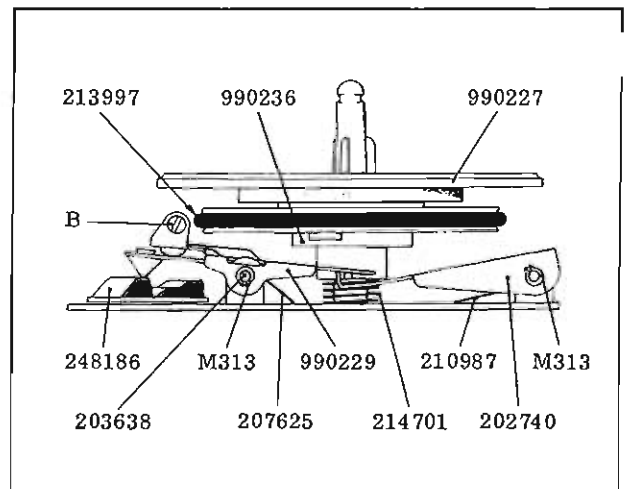

Fig. 4.21 Take-up turntable



## Supply Turntable

This turntable has a maximum torque in fast reverse winding. The operating arm is in a position that allows the delrin knob on the clutch lever to rest in its lower position. The studs on the friction disc are disengaged from the clutch lever and the friction disc is pressed against the felt ring underneath the turntable by spring 218415.

### Adjustment

By means of screw A, adjust the clearance between the studs on the delrin bushing and the clutch lever to 0.5 - 1 mm (20-40 mil). The winding torque should be minimum 600 g cm (8.3 oz. in.). Check the position of the clutch levers for all positions of the operating lever and seal screw A.

## Take-Up Turntable

The take-up turntable is released in fast reverse winding. Upper clutch lever 990229 depresses lower clutch lever 202740 and the friction disc.

### Adjustment

By means of screw B adjust the clearance between the friction disc and the felt ring underneath the turntable to 0.5 - 1 mm (20 - 40 mil). Check the position of the clutch levers for all positions of the operating lever and seal screw B.

### 4.3.5 Free

The motor is switched off by switch 202151 and both friction discs are stationary.

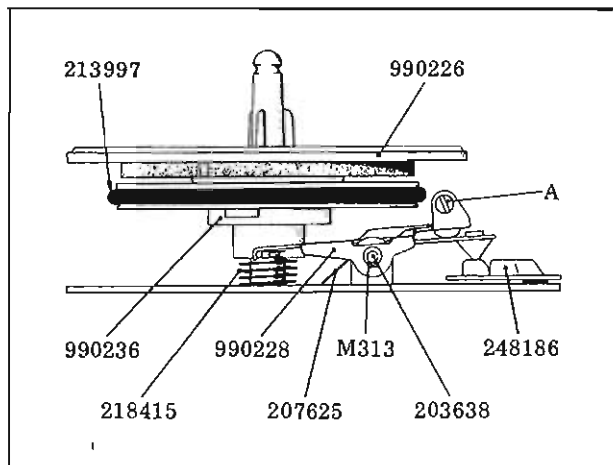

Fig. 4.22 Supply turntable

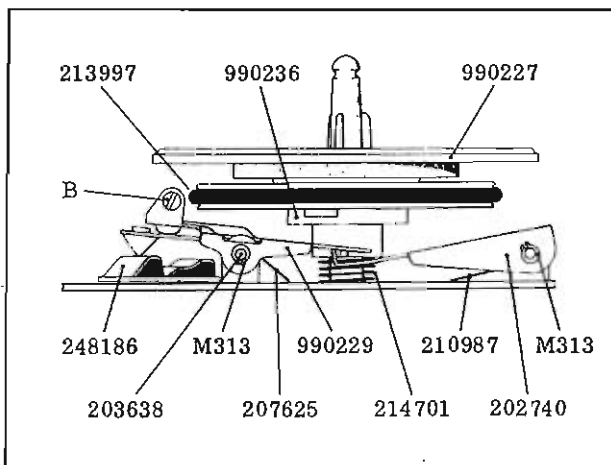

Fig. 4.23 Take-up turntable

## Supply Turntable

The supply turntable is released. For adjustment, see chapter 4.3.3.

## Take-Up Turntable

The take-up turntable is released. For adjustment, see chapter 4.3.4.

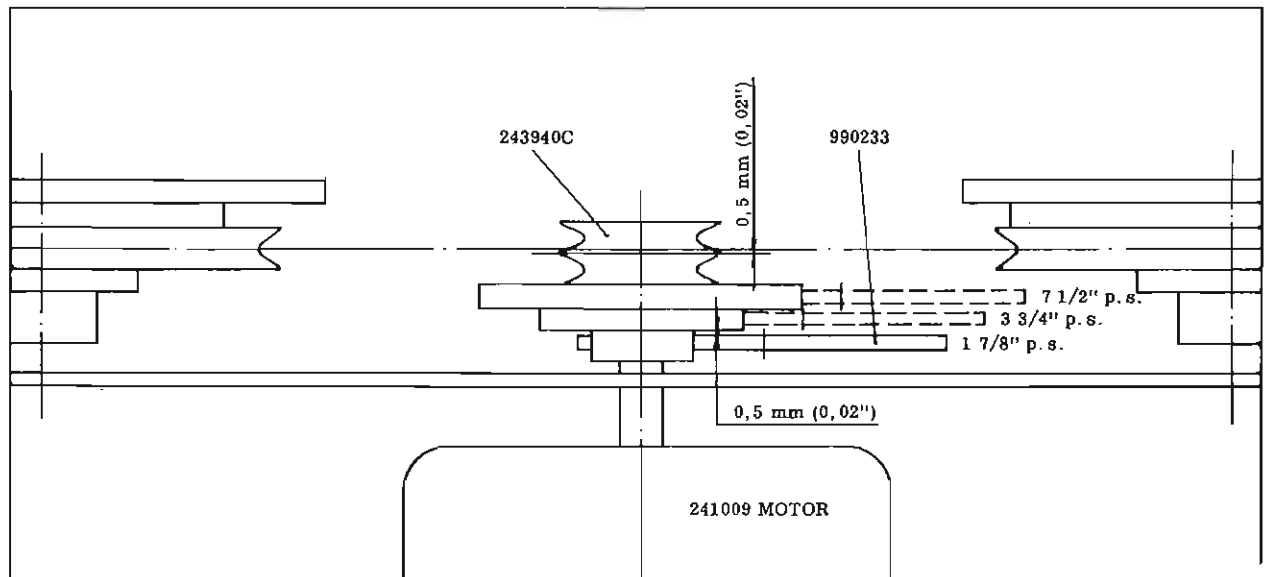

Fig. 4.24 Motor pulley w/ turntables. Rear view

#### 4.4 MOTOR PULLEY 243940C

The model 1600X has three tape speeds: 1 7/8, 3 3/4 and 7 1/2 ips, as determined by the diameter of the motor pulley track. Fig. 4.24 is a rear view of the drive mechanism with transfer wheel 990233 engaged with the motor pulley track for 1 7/8 ips.

#### Adjustment

The vertical position of the motor pulley can be adjusted when operating lever is in neutral position (center position). The dividing rib on the motor pulley should lie 0.5 mm (20 mil) below an imaginary line drawn between the bottom of the belt grooves on the friction discs.

#### 4.5 DRIVE BELT 213997

The drive belt is cross threaded, so as to run in the upper track at the front side of the motor pulley and in the lower track at the rear side. The belt crossing should lie between the supply turntable and the motor pulley.

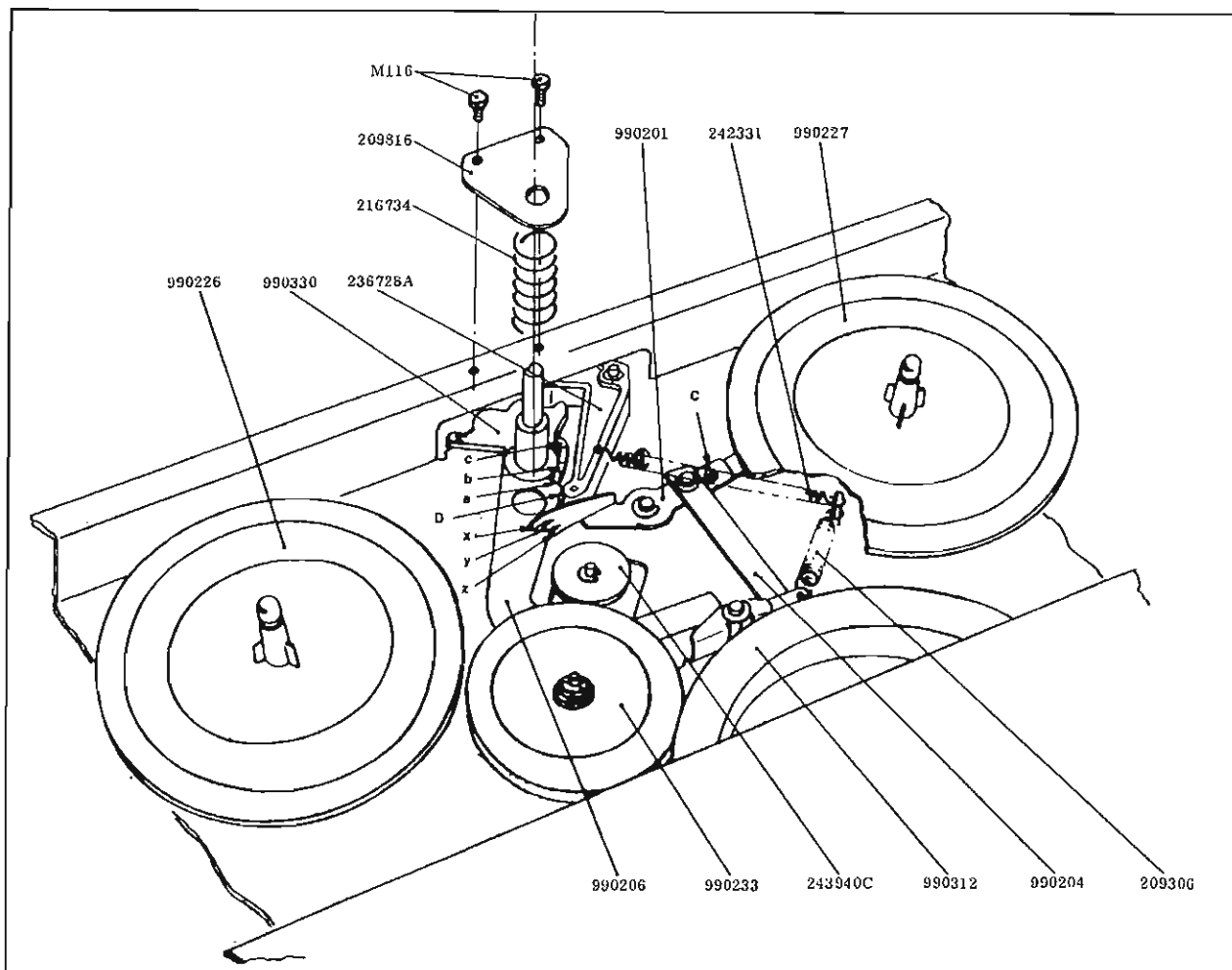

Fig. 4.25 Speed selector mechanism

#### 4.6 TRANSFER WHEEL 990233

The transfer wheel is attached to mounting arm (990206) and serves as the speed transfer medium between the motor pulley and the flywheel. Spring 209306 provides the required pressure against these two wheels. See fig. 4.25.

##### Adjustment

Set the speed selector to position  $1 \frac{7}{8}$  ips. Loosen screws M116, and adjust speed selector bracket 209816 for a clearance of 1 mm (40 mil) between the mounting

arm and lower mounting plate. Ensure that the mounting arm is parallel with lower mounting plate. The clearance between the transfer wheel and the  $3 \frac{3}{4}$  ips track on the motor pulley should be approx. 0.5 mm (20 mil). If necessary, adjust the vertical position of the transfer wheel by adding or removing turbax washers in upper or lower flywheel bearing respectively. Set the speed selector to  $3 \frac{3}{4}$  ips and  $7 \frac{1}{2}$  ips. The full width of the transfer wheel should engage with the motor pulley and the flywheel in all speed positions.

#### 4.7 LIFTING ARM 990201

The lifting arm (consisting of parallel arm and adjustment arm) is located on the lower mounting plate and is linked with eccentric segment 990203. See fig. 4.25. The lifting arm disengages transfer wheel 990233 from the motor pulley when the operating lever is set to position fast forward winding, reverse winding, free, or neutral. The transfer wheel should engage with the motor pulley in normal forward drive mode only.

##### Adjustment

For each one of the tape speeds the transfer wheel should leave the motor pulley as soon as the operating lever is moved from normal forward drive position to neutral position, and reach maximum clearance before the motor is switched off by microswitch 202151. The minimum clearance in neutral position should be 3 mm ( $1/8$ "'). If

necessary, adjust by bending the lifting arm fingers x, y, and z for relevant speeds. Set the speed selector for 1 7/8 ips and the operating lever to neutral position. Loosen screw C and adjust the parallel arm 990204 for

0.5 mm (20 mil) clearance between the transfer wheel and the flywheel. Set the speed selector for 3 3/4 ips and 7 1/2 ips and check that the clearance is the same. Readjust if necessary, tighten and seal screw C.

#### 4.8 FLYWHEEL WITH CAPSTAN 990312

The flywheel and the capstan comprises one integral part with the flywheel shaft serving as capstan. The unit is mounted in selflubricating bearings 208250, see fig. 4.27.

#### Adjustment

For vertical adjustment of the capstan, use special tool no. 5 as shown in fig. 4.26. Loosen the two screws M125 in washer 990223 in the upper flywheel bearing. Push the tool cautiously down on to the capstan until all three legs rest against the upper mounting plate. Then tighten screws M125, and remove the tool. Wipe off any impurities on the capstan by means of a clean piece of cloth.

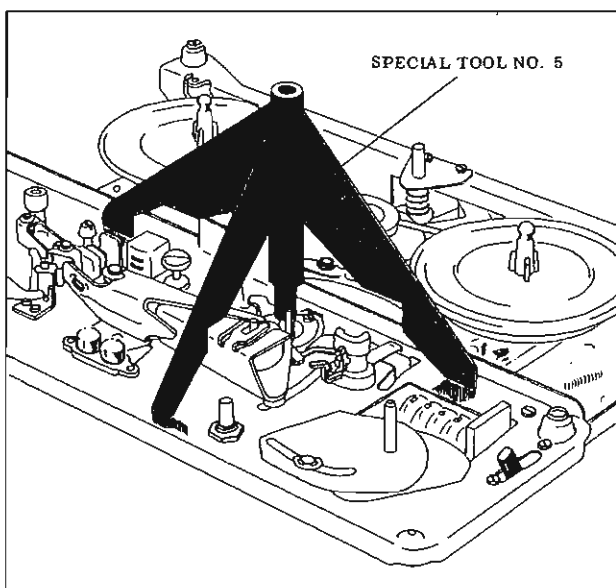

Fig. 4.26 Adjustment of capstan

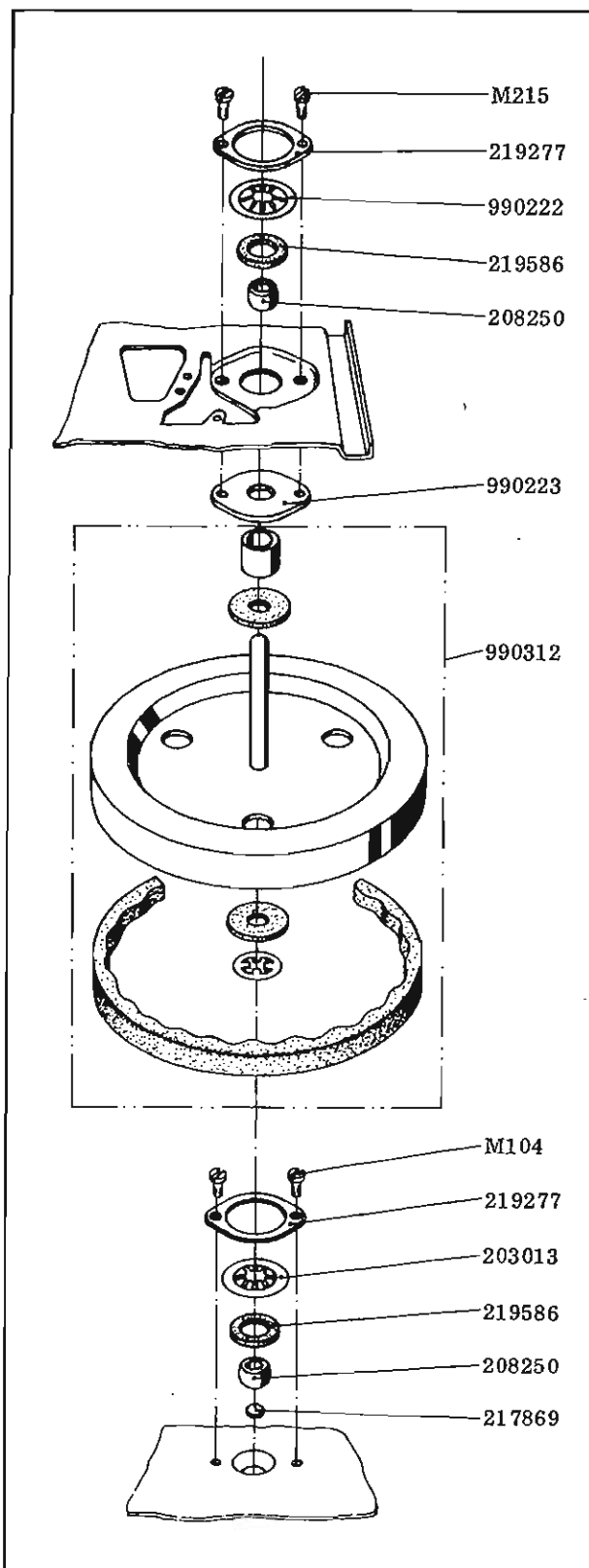

Fig. 4.27 Flywheel w/capstan

1652X

## 4.9 SPEED SELECTOR

Fig. 4.26 shows the design and operation of the speed selector. The transfer wheel is shown in engagement with the 1 7/8 ips track on motor pulley 243940C. Mounting arm 990206 is engaged with the lowest step on cam disc 990330, and arm 236728A rests against the curved edge of the cam disc. When the speed selector is moved towards the 3 3/4 ips position, the arm presses

against the mounting arm at point D, and moves the arm and the transfer wheel approx. 1 cm (3/8") horizontally to the left. The vertical movement of the mounting arm occurs simultaneously and is controlled by the slope between steps a and b on the cam disc. The transfer wheel moves horizontally towards the 3 3/4 ips track on the motor pulley. When the movement is completed, the cam disc arm returns to normal position. No adjustments are provided for the speed selector mechanism.

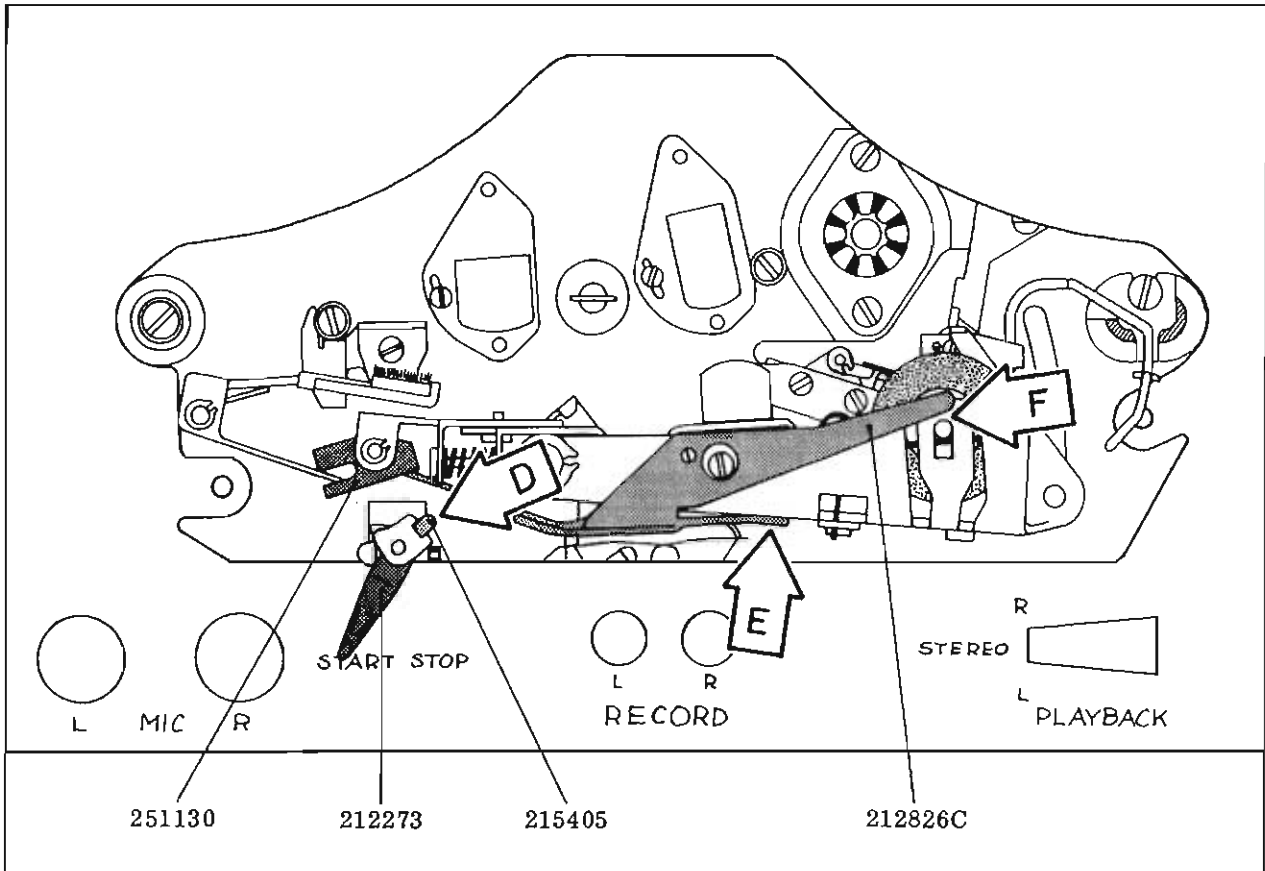

Fig. 4.28 Adjustment of start/stop mechanism

## 4.10 INSTANTANEOUS START/STOP MECHANISM

See fig. 4.28. When start/stop lever 212273 is moved towards stop position, delrin part 215405 is pressed against forked lever 212826C at point D. The lever moves the pressure roller away from the capstan, and the tape stops.

### Adjustment

Set the operating lever to normal forward drive position and the start/stop lever to STOP position. Adjust the pressure roller lever by bending flap E to obtain a clearance of 0.5 mm (20 mil) between capstan and the pressure roller. Check that the clearance between the

pressure roller lever and linkage 251130 is approx. 0.2 mm (8 mil). Start the tape by moving the start/stop lever to the left. Adjust the clearance at point F between the pressure roller lever and the pressure roller shaft approx. 1 mm (40 mil) by bending tongue E. Finally check that the clearance between the forked lever and delrin part 215405 is approx. 0.5 mm (20 mil).

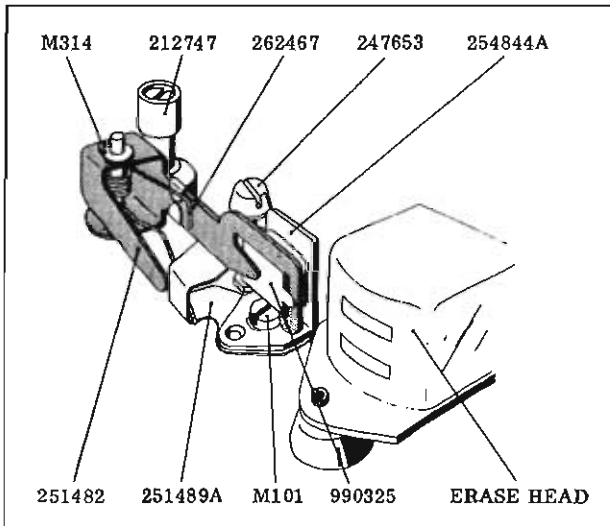

Fig. 4.29 Pressure pad mechanism

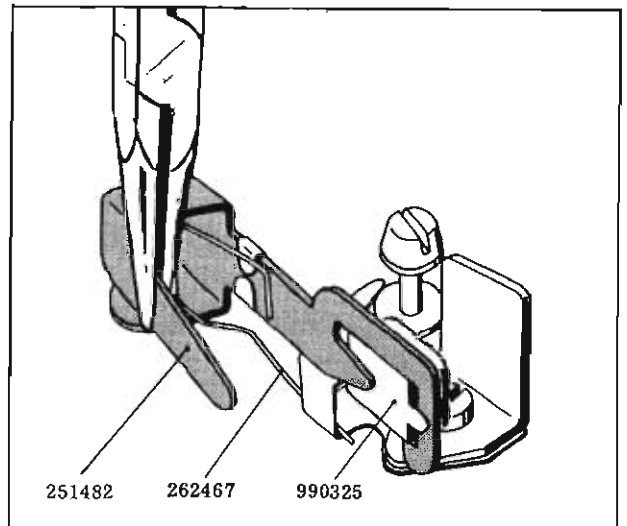

Fig. 4.31 Adjustment of pad's position

### 4.11 PRESSURE PAD

Pressure pad 990325 is attached to lever 251482. The pressure pad is pressed against tape rest 254844A, and ensures constant tape tension in normal forward drive mode. See fig. 4.29. When the operating lever is in any other position, the pressure pad is kept at a distance from the tape.

#### Adjustment

Set the operating lever to neutral position. The clearance between the pressure pad and the tape rest should be approx. 6.5 mm (1/4") as shown in fig. 4.30. If necessary, adjust by bending arm 251482 as shown in fig. 4.31.

Set the operating lever to normal forward drive position. The pressure against the tape rest should be 80 g (2.8 oz)  $\pm$  10%, see fig. 4.32. If necessary, adjust by bending spring 262467 as shown in fig. 4.33.

**Note:** The pressure pad should be brushed clean at regular intervals to avoid incorrect friction being caused by dust and other impurities. The pad must not be dampened in any way, as this will alter the surface structure and properties of the pad.

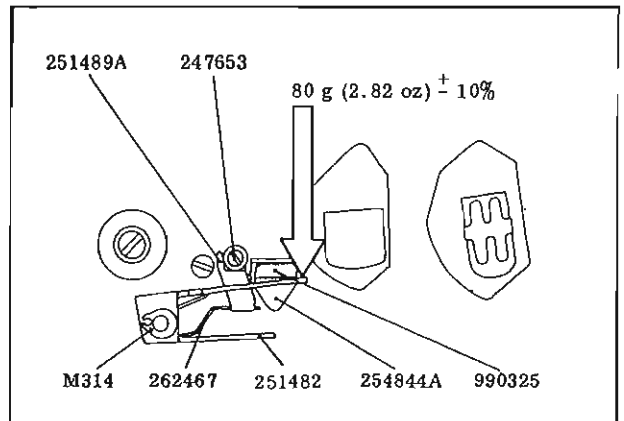

Fig. 4.32 Pressure of pad

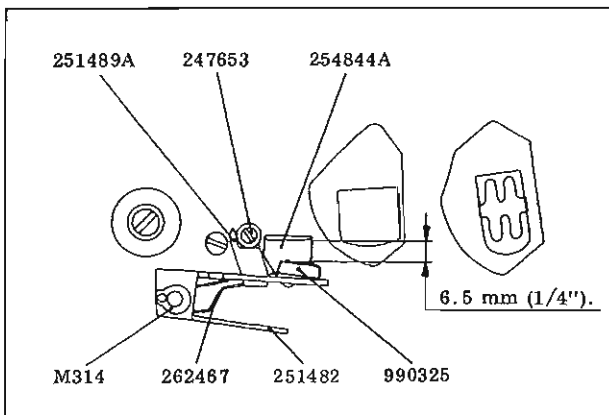

Fig. 4.30 Position of pad

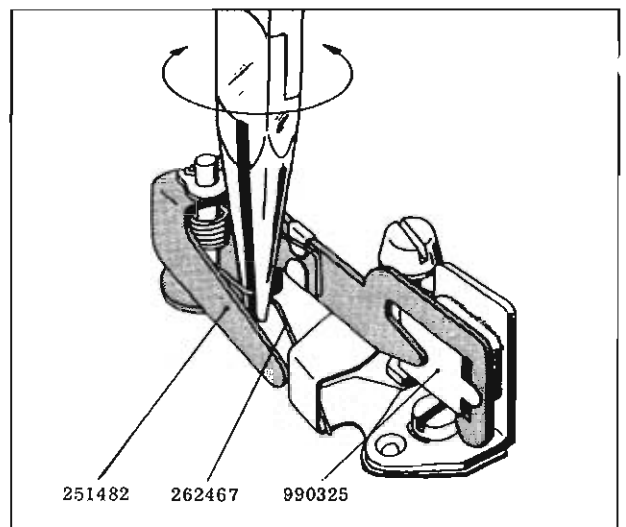

Fig. 4.33 Adjustment of pad's pressure

## 4.12 END STOP MECHANISM

The purpose of the automatic end stop mechanism is to switch off the motor at the end of the tape or in a case of tape breakage. End stop feeler 242503 is located on the upper mounting plate and extends through the cross-shaped hole in right hand guide post 24 3013. The

### 4.12.1 Neutral

Figure 4.39 shows the position of the relevant parts when the operating lever is in neutral (stop). Arm 244694A has a flap extending through upper mounting plate, and is thereby held in an intermediate position by the operating lever. The arm attacks the tape feeler at point A and keeps the feeler clear of the guide post. Arm 244694A exerts pressure on lever 244342A at point B and the microswitch is depressed to its OFF position.

feeler operates microswitch 202151 via lever 244342A, and rests with a light spring tension against the tape when the operating lever is in normal forward drive, and winding positions.

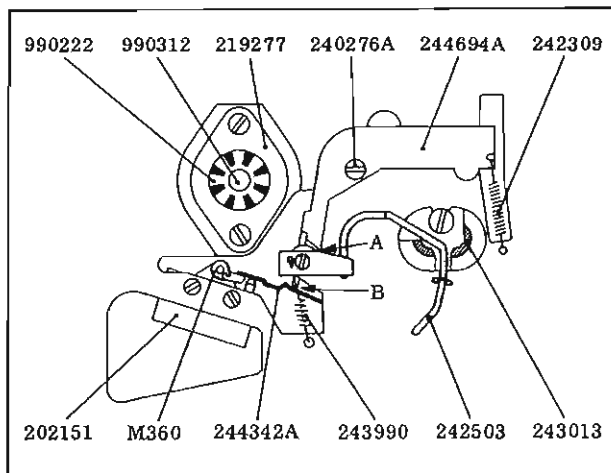

Fig. 4.34 Neutral

### 4.12.2 Normal Forward Drive

Fig. 4.35 shows the situation when the operating lever is set to normal forward drive, forward or reverse winding, with a tape properly inserted in the tape path. Arm 244694A is now moved by the operating lever in forward direction, and the pressure against the tape feeler at point A ceases. Simultaneously, the pressure at point B ceases, because arm 244694A, which rests in a groove of the lever 244342A, is released. The microswitch returns to closed position and the motor starts. The tape feeler rests gently against the tape, due to the tension of spring 243990.

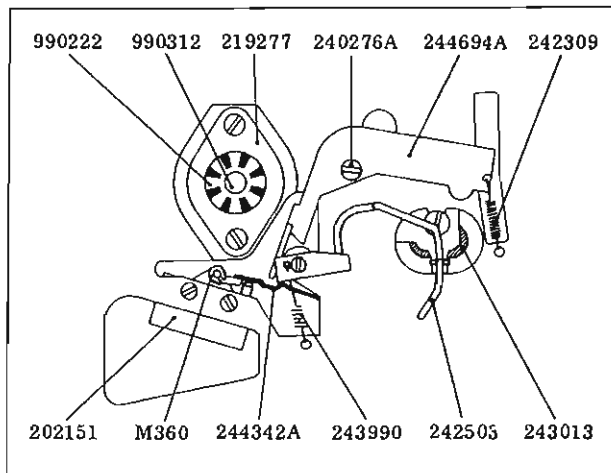

Fig. 4.35 Normal forward drive

### 4.12.3 Free

Fig. 4.36 shows the position of the relevant parts when operating lever is in position FREE. Arm 244694A is moved in a direction away from the normal forward drive position. The tape feeler is locked in open position at point D and the tape can be inserted. Lever 244342A is locked in position E, holding the microswitch depressed (motor switched off).

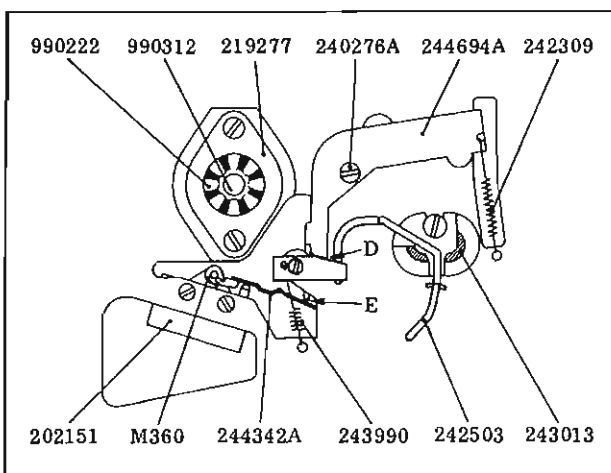

Fig. 4.36 Free

#### 4.12.4 End Stop or Tape Breakage

Fig. 4.37 shows the situation when the tape has run out, or a case of tape breakage.

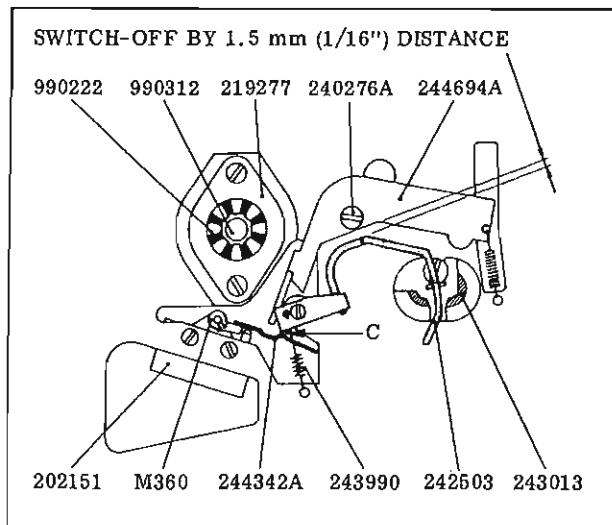

Fig. 4.37 End stop or tape breakage

#### 4.12.5 Tape Feeler Tension

The feeler tension against the tape should be between 8 and 10 gr (0.28 - 0.35 oz.) in drive and winding modes. Adjustment of the tension is accomplished by tightening or slackening spring 243990.

#### Adjustment of Tape Feeler Movement

For adjustment of the tape feeler movement refer to fig. 4.38. Set operating lever in normal forward drive position, or forward or reverse winding. The mains switch is set to ON. No tape should be inserted. The tape feeler will therefore rest in the position where the motor is switched off. Push the feeler slowly through the guide post. When the contact surface (polished) of the feeler is 0.5 - 1.0 mm (20-40 mil) from the polished contact surface of the guide post, the microswitch should close and start the motor. If not, loosen screw F, and move the microswitch slowly until the motor starts when the tape feeler is hold in the position specified above. Then tighten the screw. When the tape feeler is released, the microswitch should open, and switch off the motor when the spacing between the tape feeler and arm 244694A is maximum 1.5 mm (60 mil). See fig. 4.37.

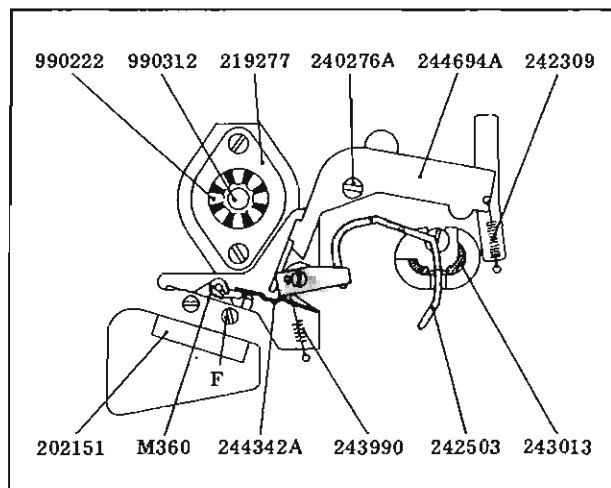

Fig. 4.38 Adjustment



# 5.0 ELECTRONIC CIRCUITS

## Detailed Description

### 5.1 THE MAIN ELECTRONIC UNITS, BLOCK DIAGRAM

The simplified block diagram for Tandberg Tape Recorder Models 1600X four track and two track, is shown in fig. 5.0. The tape recorder is equipped with the following electronic units.

The amplifiers are identical for the two channels and only the amplifiers for channel L are therefore explained in the following descriptions.

- 2 Microphone/line amplifiers
- 2 Buffer amplifiers
- 2 Equalized record amplifiers
- 2 Level indicator amplifiers
- 2 Equalized playback amplifiers
- 1 Oscillator, bias and erase circuit
- 1 Power supply
- 2 Playback booster amplifiers.

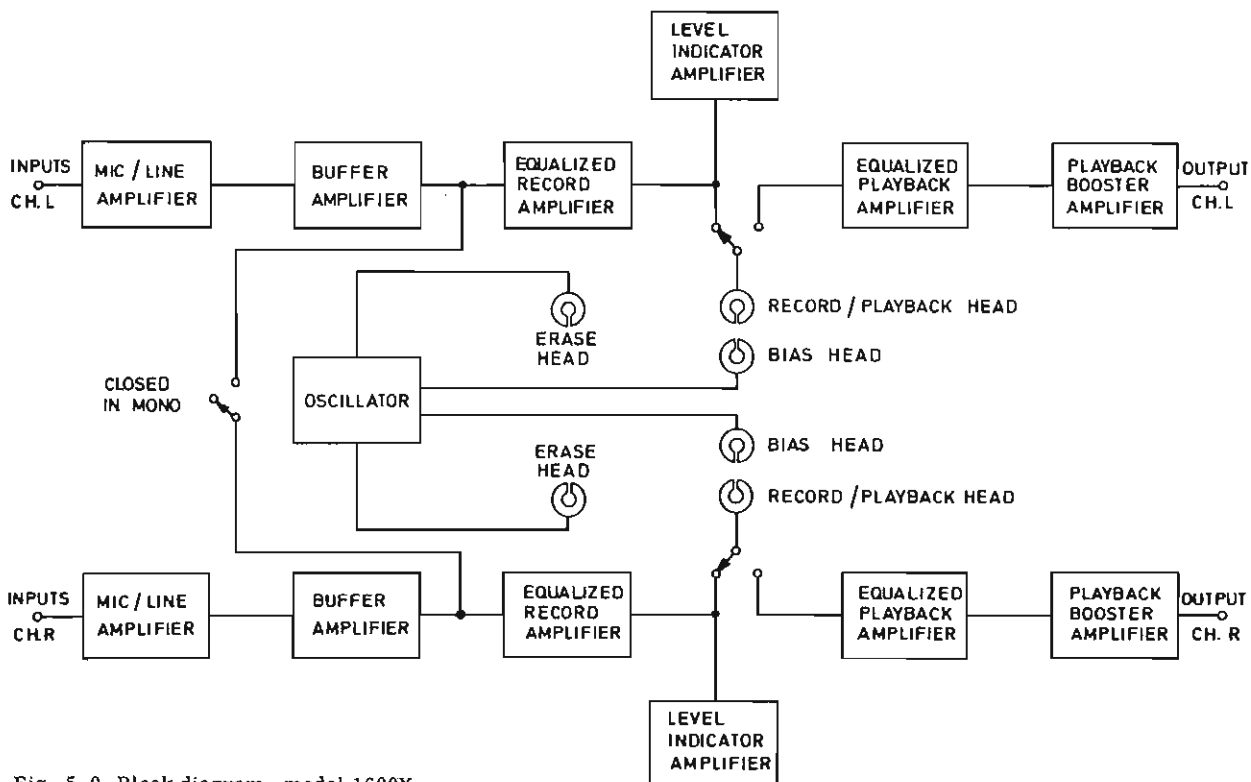

Fig. 5.0 Block diagram, model 1600X

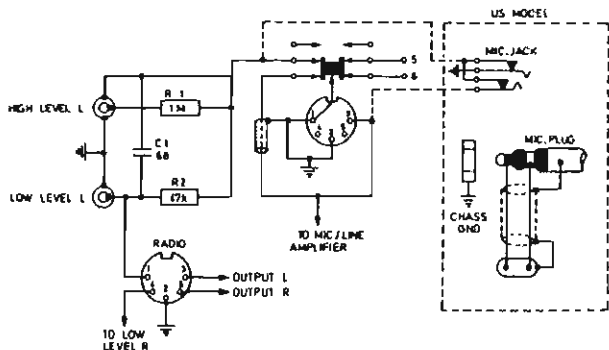

Fig. 5.1 Input circuits

#### 5.1.1 Inputs

The wiring diagram for the input circuits is shown in fig. 5.1.

The circuit framed by the dotted lines is applied on the U.S. version. Instead of DIN-sockets for microphones connections, the U.S. version is equipped with standard telephone jacks. When microphone is plugged in the respective HIGH LEVEL, LOW LEVEL and RADIO pin are automatically disconnected.

### 5.1.2 Microphone and Line Amplifier

The circuit diagram for microphone and line amplifier is shown in fig. 5.2. The amplifier is a two transistor stage, consisting of Q101 and Q102. The total amplification of the stage is 100, when applying as microphone amplifier, and 10 when it is used as line amplifier. The line amplification is achieved when R110 is connected in parallel with R109. The parallel connection increases the feedback which reduces the amplification by a factor of 10. The capacitor C135 is introduced to remove radio signals while R104 stabilizes the operating point. The signal is fed via C104 to potentiometer R108 in the buffer amplifier.

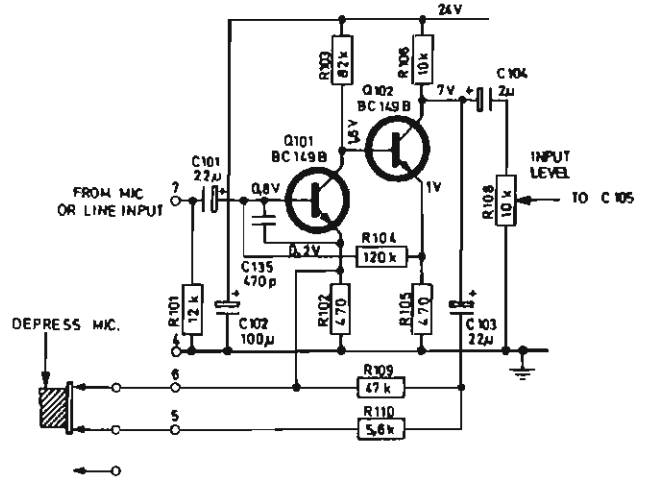

Fig. 5.2 Microphone and line amplifier

NOTE: On the U.S. version of Model 1600X, the feedback resistor R110 is omitted and R101 is changed from 12 kohm to 1 kohm.

### 5.1.3 Buffer Amplifier

Fig. 5.3 shows the circuit diagram for the buffer amplifier. The amplifier consisting of transistors Q103 and Q104 has a flat frequency response with an amplification of approximately 13. The amplification of the stage is reduced by a factor of two (6 dB) when the buffer amplifier outputs are connected in mono recording. The output signal from Q104 is fed via C107 and R116 to the equalized record amplifier.

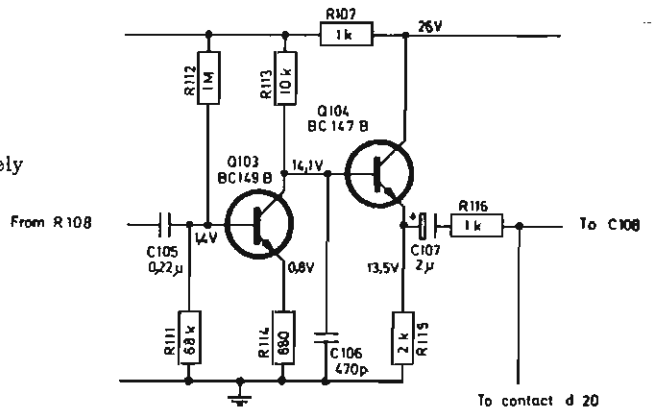

Fig. 5.3 Buffer amplifier

### 5.1.4 Record Equalizing Amplifier

Circuit diagram for the record equalizing amplifier contains the transistors Q105 - Q106 and Q107, shown in fig. 5.4. Equalizing of the bass response is obtained by the capacitor C114 parallel to C136 and R125 in series. The treble response is in tape speed 7 1/2 ips formed by the T-filter C119, C120 and R154 and the components R126 and C115. R126 form the peak value of the treble range, see fig. 5.5.

The 3 3/4 ips treble response is determined by the T-filter and a second filter consisting of R256 and C117. The peak value (of treble range) is obtained by R156. At tape speed 1 7/8 ips, the treble response is formed by T-filter and a filter consisting of R129 and C116. Total amplification of the stage is approximately 20.

The resistor R121 is introduced to stabilize the operating point while R117 is feedback resistor. The signal is fed to the record/playback head via C111 and R130.

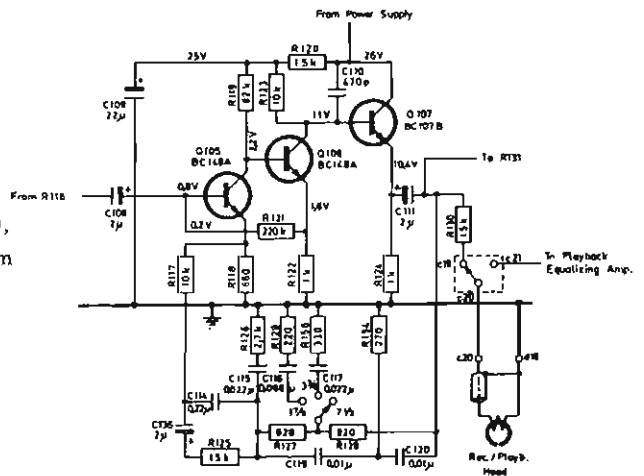

Fig. 5.4 Record equalizing amplifier

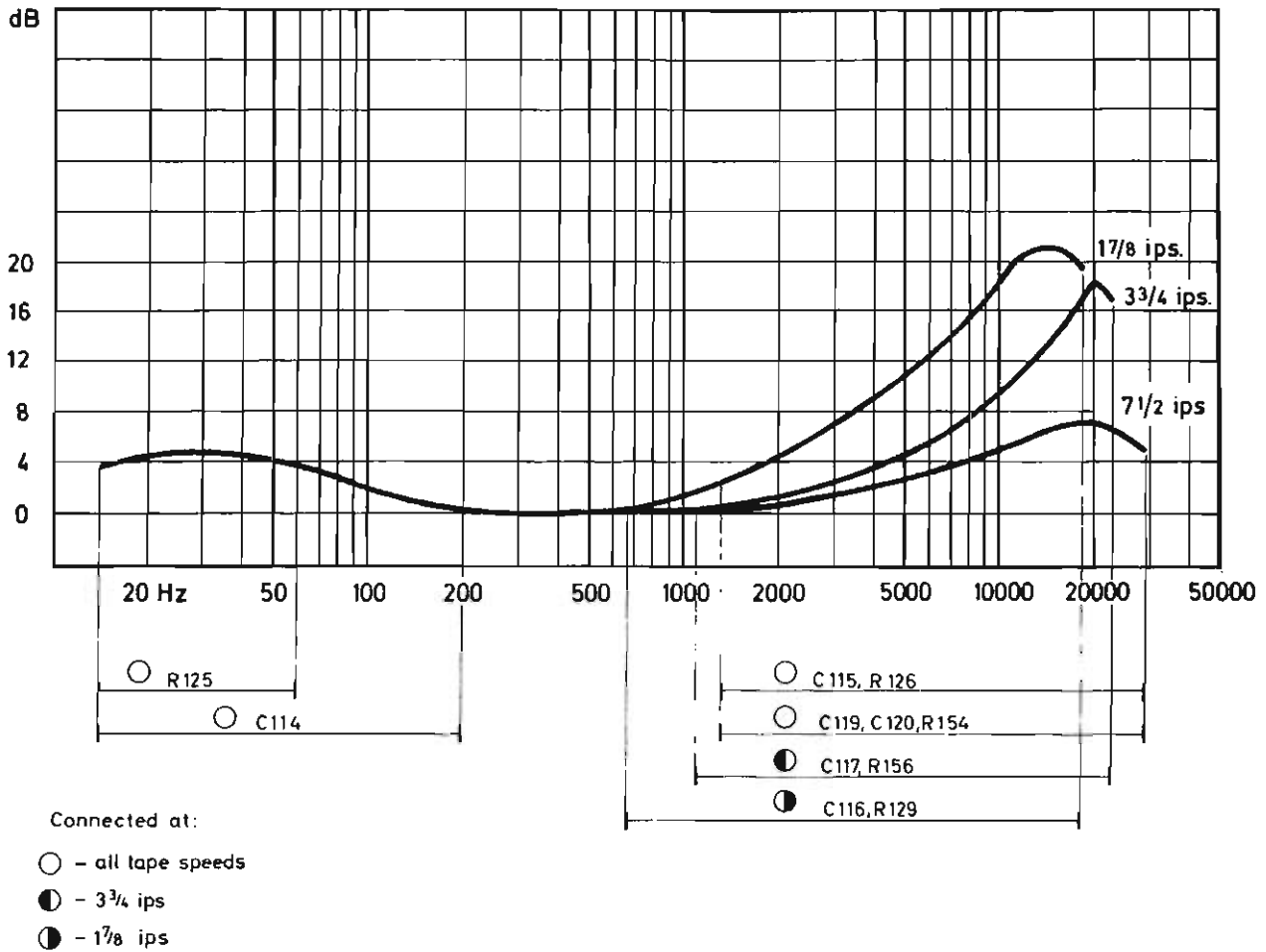

Fig. 5.5 Recording curves with equalizing components activated at the different tape speeds

### 5.1.5 Indicator Amplifier

The circuit diagram for the indicator amplifier, consisting of Q108 as an active element, is shown in fig. 5.6. The signal is fed to base of Q108 via C112 and the record level adjustment potentiometer R131. As Q108 has no bias voltage, Q108 conducts only at positive half periods of the signal. C113 will be charged when Q108 is active. If the signal level should decrease, C113 would be slowly discharged through R134 and the instrument, thus causing a slow return of the instrument needle deflection.

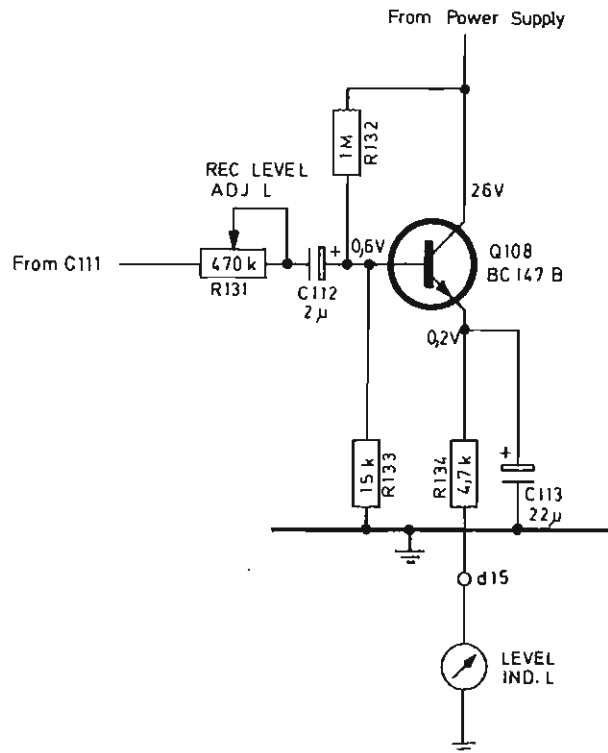

Fig. 5.6 Indicator amplifier

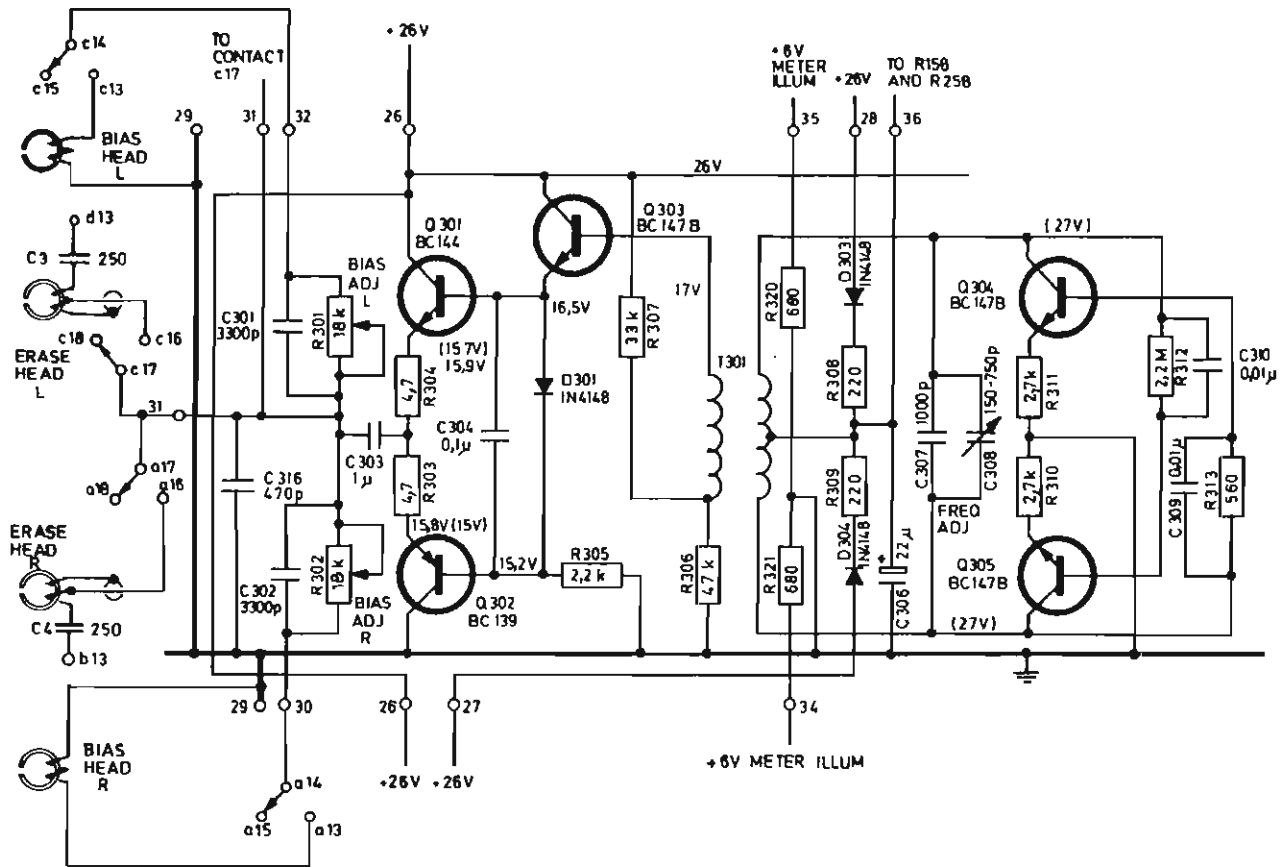

Fig. 5.7 Oscillator, bias and erase circuits

### 5.1.6 Oscillator with Amplifier, Bias- and Erase Circuits

Fig. 5.7 shows the circuit diagram for the oscillator with amplifier, bias and erase circuit.

The oscillator signal is generated by transistors Q304 and Q305 which are push-pull connected.

The oscillator frequency (85.5 kHz) is decided of transformer T301, capacitor C307 and trimming capacitor C308. The line voltage is fed to the oscillator via the mode switch when this is depressed, record position. The diodes D303 and D304 are preventing illumination of the indicator that is not

applied for the recording. The oscillator voltage is fed via the transformer T301 to the oscillator amplifier consisting of Q301, Q302 and Q303. Q301 and Q302 are connected in push-pull. Diode D301 is introduced to suppress cross-over distortion. The signal is fed via C303 and the switching system to the respective heads being in operation. The bias is adjusted with potentiometers R301 and R302 for channel L and R respectively.

## 5.2 PLAYBACK ELECTRONICS

### 5.2.1 Playback Equalizing Amplifier

The playback equalizing amplifier consisting of Q109, Q110 and Q111 is shown in fig. 5.8. Bass response is determined by the connection of R144 and C127.

The treble response is at tape speed 7 1/2 ips formed by capacitor C121. At tape speed 3 3/4 ips, the high frequency response is obtained by capacitors C121 and C122.

The capacitors C121 and C123 form high frequency response at 1 7/8 ips. Amplification of the stage is approximately 200. R137 is introduced to stabilize the operating point. The signal is fed via C128 and R146 to playback booster amplifier.

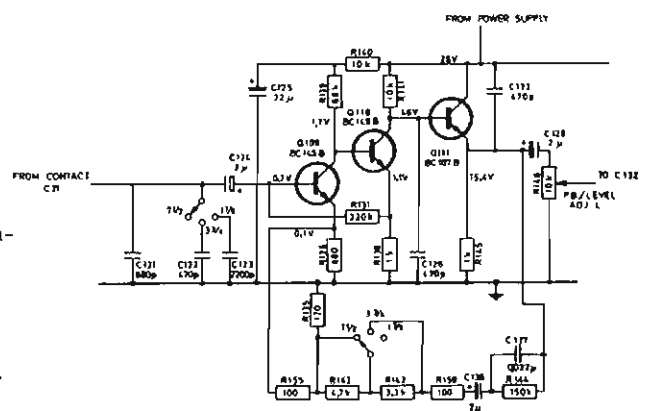

Fig. 5.8 Playback equalizing amplifier

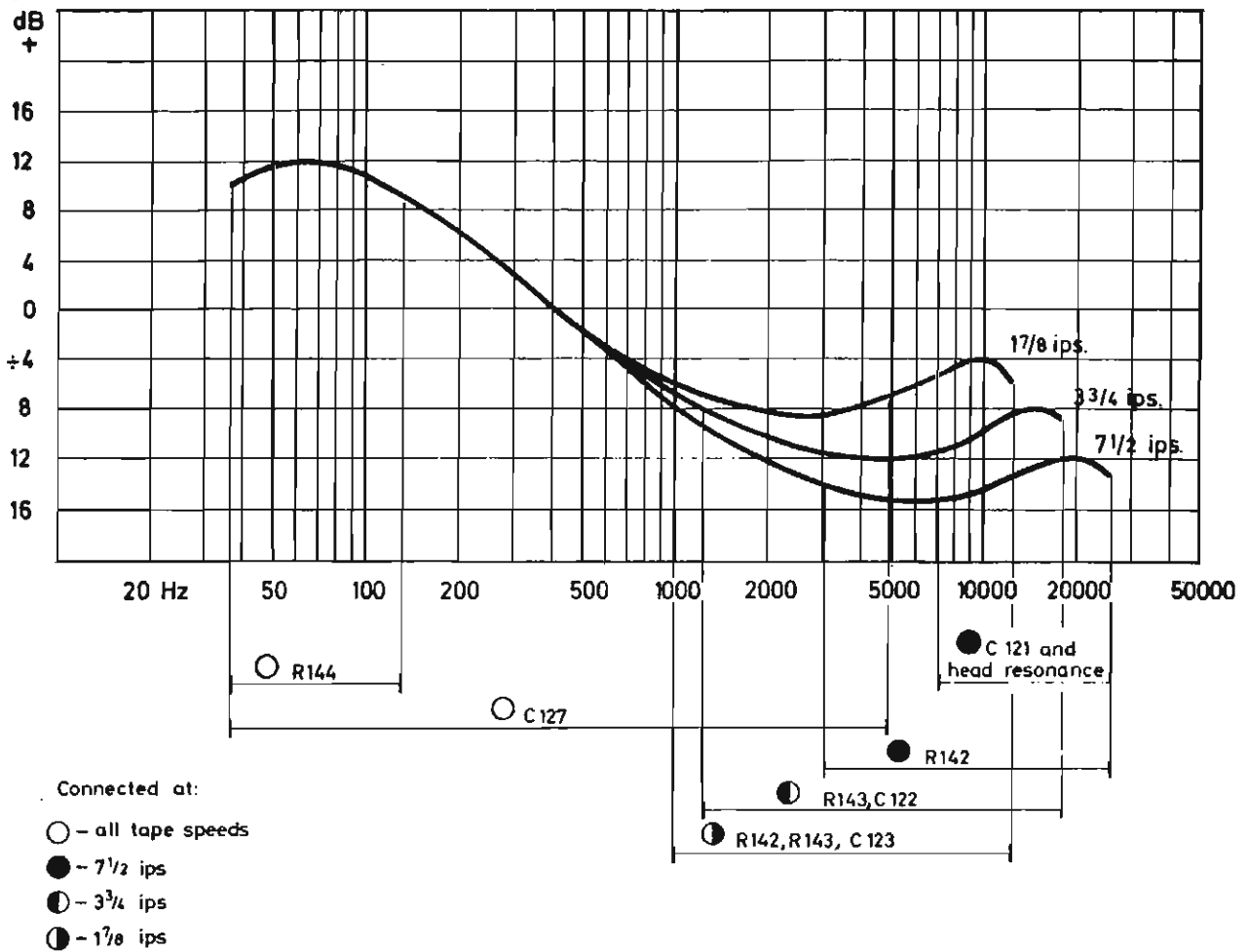

Fig. 5.9 Playback curves with equalizing components activated at different tape speeds

### 5.2.2 Playback Booster Amplifier

Transistors Q112, Q113 and Q114 are active elements of playback booster amplifier, shown in fig. 5.10, (circuit diagram). The feedback resistor R152 sets the amplification of the stage to approximately 30. R149 stabilizes the operating point. The signal is fed via C130 and playback selector to the output terminals. During mono or stereo recording, a positive voltage is fed via R158 to emitter of Q112. The emitter will be positive with respect to the base, and Q112 will be in cut-off.

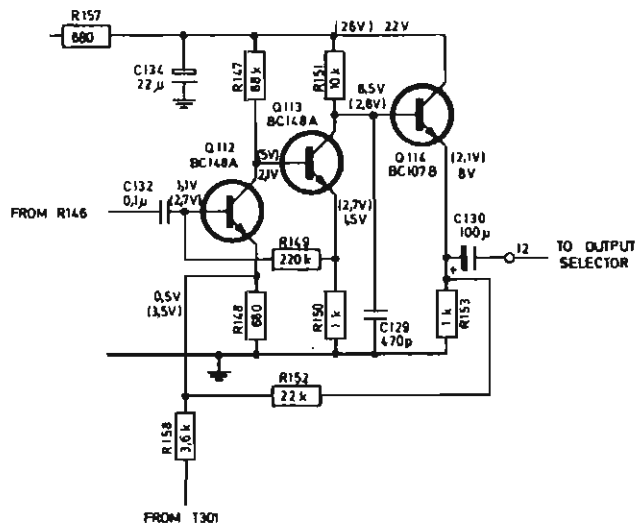

Fig. 5.10 Playback booster amplifier

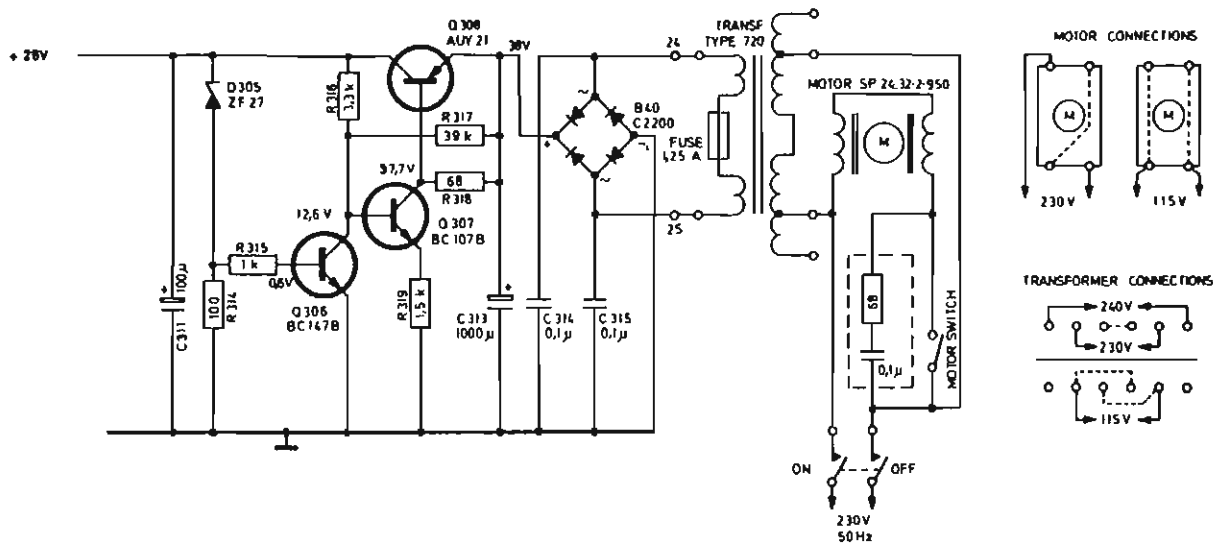

Fig. 5.11 Power Supply

### 5.3 POWER SUPPLY

Circuit diagram for the power supply is shown in fig. 5.11. The line voltage +26V is stabilized by transistors Q306, Q307, Q308 and diode D305. Q308 operates as a variable resistor. Q306 is a DC connected transistor controlled by the variations of the line load. The zener diode D306 is used as reference voltage. The DC signal from Q306 is fed to Q307 which controls Q308.

## 5.4 OUTPUT SWITCHING SYSTEM

### 5.4.1 Playback Selector with Output Receptacles

Fig. 5.12 shows the playback selector switch and the output receptacles. The playback selector is shown in STEREO position. The switch has three positions:

- Position L: Signal from left playback amplifier is fed to output receptacles on both channels.
- Position R: Signal from right playback amplifier is fed to output receptacles on both channels.
- Position STEREO: The two channels are separated and the signals from left and right playback amplifiers are fed to their respective output receptacles.

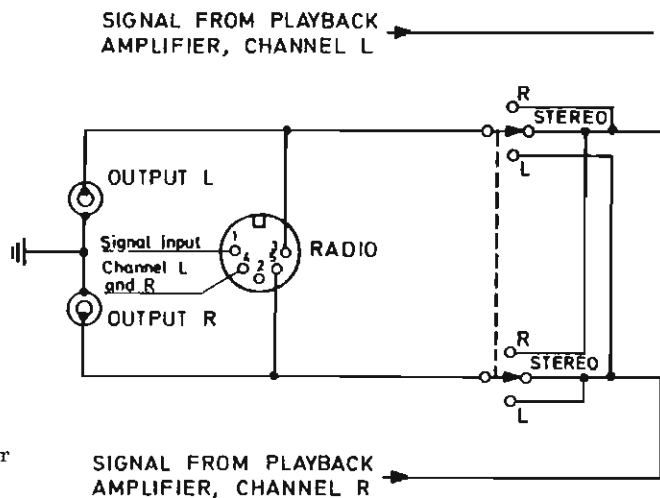

Fig. 5.12 Output switching system

## 6.0 ALIGNMENT OF ELECTRICAL CIRCUITS AND TAPE PATH

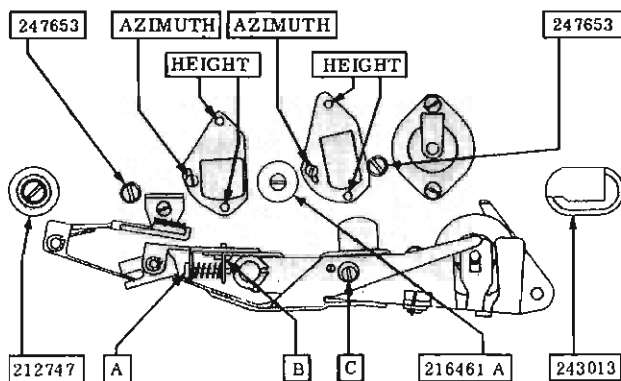

Fig. 6.0 Heads and tape path with adjustment screws

### 6.1 HEAD ALIGNMENT AND TRACK CONTROL WITH TANDBERG TEST TAPES

#### 6.1.1 Model 1641X (Four Track)

#### 6.1.2 Demagnetizing

Demagnetize heads and adjacent parts before and after aligning of heads.

#### 6.1.3 Tape Guide Adjustment

Insert tape, and move the operating lever slowly towards normal drive position with taut tape. Check that the tape does not touch flanges of the tape guides during operation of lever. If necessary, align the vertical position of the adjustable tape guides (247653) and (216461A) until the tape runs equidistant from the flanges of the tape guides.

#### 6.1.4 Record/Playback Head

#### 6.1.5 Height Adjustment

Play back Tandberg Test Tape no. 1. This is a full track prerecorded tape with 1 000 Hz recorded at 7 1/2 ips. The recording level in the exact area corresponding to track 3 (channel R) is reduced by approx. 30 dB. Adjust the height of the combined record/playback head until minimum output level from track 3 is obtained on a VTVM.

#### 6.1.6 Azimuth Adjustment

Play back Tandberg Test Tape No. 2. This is a full track prerecorded tape containing 15 000 Hz at tape speed 7 1/2 ips. Adjust the azimuth position of the record/playback head until maximum output level is obtained across both output terminals. Ref. paragraph 6.3.4 for lateral adjustment.

#### 6.1.7 Control of Playback Curves

Play back Tandberg Test Tape no. 3. This is a full track prerecorded tape recorded at tape speed 7 1/2 ips, containing the following frequencies: 250-10 000-5 000-1 000-100-50 and 250 Hz. Output tolerances: At 10 000 Hz: 0 to +4 dB.

At 5 000 Hz: - 1 to +3 dB. At 1 000 Hz and lower frequencies:  $\pm 2$  dB. The reason for these particular tolerances is that Tandberg Test Tape no. 3 is recorded according to NAB Standard, 50  $\mu$ s, while model 1600X has playback equalization according to 60  $\mu$ s, at tape speed 7 1/2 ips. This is an average value of NAB and IEC Standards. The IEC Standard specifies 70  $\mu$ s. The difference in level between the two channels should be less than 4 dB.

#### 6.1.8 Erase Head

#### 6.1.9 Height Adjustment

Set the erase head to preliminary position where approx. 0.25 mm (0.01") of the ferrite core for upper track is visible above the tape. Insert Tandberg Test Tape no. 9 and record with overloaded signal level (+20 dB) a 1 000 Hz signal from a generator on channel R (track 3). Dip the tape into Magna See solution and check that the prerecorded track is centered in the erased area. Adjust the height position of the erase head if necessary. Make sure that none part of the neighbour tracks are erased. Ref. paragraph 6.3.7 for lateral adjustment. Ref. paragraphs 6.6.6 and 6.6.8 for adjustment of bias head.

### 6.2 MODEL 1621X (TWO TRACK)

All alignment specified in paragraph 6.1 are valid for Model 1621X with the exception of paragraphs 6.1.5 and 6.1.9 which are respectively superseded of paragraphs 6.4.1 and 6.4.2.

Note: Final adjustment of erase head or record/playback head must be an azimuth adjustment. When record/playback head has been adjusted, the bias has to be readjusted, ref. para. 6.6.8.

### 6.3 HEAD ALIGNMENT WITHOUT TANDBERG TEST TAPES

#### 6.3.1 Demagnetizing

Demagnetize the heads and adjacent parts before and after alignment of heads.

#### 6.3.2 Record/Playback Head

#### 6.3.3 Height Alignment

The height of the record/playback head is aligned by the height adjustment screws, ref. fig. 6.0. The upper edge of the tape shall run flush with upper headhalf's upper edge. Ref. para. 6.4.1 and 6.5.2 for track control of record/playback head.

### 6.3.4 Lateral Alignment

Before performing lateral alignment, the azimuth alignment has to be accomplished, ref. para.6.3.5

Pull the pressure pad away from the tape angular plate when playing back standard azimuth alignment tape. The output level indicated on the VTVM should not decrease by more than 3 dB. If necessary, adjust the lateral position of the head by turning the head mounting plate.

### 6.3.5 Azimuth Alignment

Play back a standard azimuth alignment tape with a VTVM connected to the output terminals. Adjust the position of the record/playback head by the azimuth adjustment screw, ref. fig. 6.0, until maximum reading is obtained on the output meter. Brake the left hand tape reel carefully. If the reading on the VTVM is increased the tape path might be incorrectly adjusted, the lateral alignment is not correctly adjusted, or the following sources of error may exist:

1. The tape does not run correctly between the flanges of the tape guide.
2. The pressure wheel and/or the capstan may be obliquely positioned.
3. Impurities on the headfronts.

When the source of the trouble has been determined, the azimuth position has to be readjusted. A maximum deflection of + 1.5 dB on the VTVM is allowed when braking the tape.

### 6.3.6 Erase Head

### 6.3.7 Height Alignment

The height position of the head is aligned with the adjustment screws shown in fig. 6.0. Approximately 0.25 mm (0.01") of the ferrite core for the upper track of the erase head should be visible above the tape. Ref. paragraphs 6.4.2 and 6.5.1 for track control of the erase head.

### 6.3.8 Lateral Alignment

Turn the head mounting plate for the erase head until the front of the head is parallel with the tape.

### 6.3.9 Azimuth Alignment

The azimuth position is regulated with the adjustment screws shown in fig. 6.0. The head plate and upper mounting plate must be parallel. The azimuth position of the erase head is not critical.

NOTE: The final adjustment of the erase head or the record/playback head must be an azimuth alignment.

After alignment of record/playback head, the bias head must be adjusted, ref. paragraph 6.6.8.

## 6.4 TRACK CONTROL, MODEL 1641X - FOUR TRACK, WITHOUT TANDBERG TEST TAPES

### 6.4.1 Record/Playback Head

Record a 1 000 Hz signal in stereo for 5 seconds at overloaded recording level (+20 dB) on tracks 1 and 3. Turn the tape around and make similar recording on tracks 4 and 2. Cut the tape and dip it into a solution of iron powder and alcohol (Magna See) to make the recording visible. The spaces between the recorded tracks should be distributed symmetrically across the tape, ref. fig. 6.1. If necessary, readjust the height position and recheck the azimuth position.

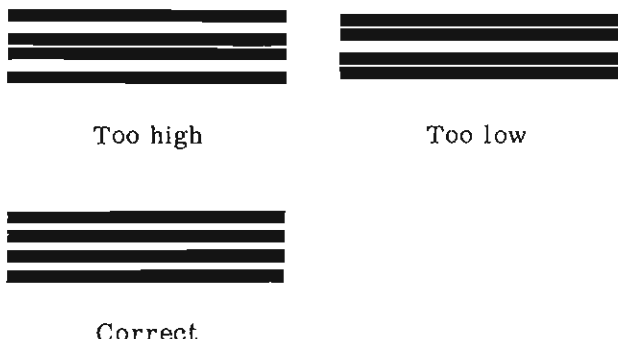

Fig. 6.1 Track measurement of record/playback head

### 6.4.2 Erase Head

Insert a full track prerecorded tape and record a 1 000 Hz signal at overloaded recording level (+20 dB), on track 3 (channel R). Cut the tape and dip it into Magna See solution. Check that the prerecorded track is centered in the erased area (ref. fig. 6.2). Adjust the vertical position of the erase head, if necessary.

## 6.5 TRACK CONTROL, MODEL 1621X - TWO TRACK, WITHOUT TANDBERG TEST TAPES

### 6.5.1 Erase Head

The height position of the erase head is aligned by the height adjustment screws, ref. fig. 6.0. The tape shall run flush with the upper edge of upper head half.

For azimuth and lateral alignment, ref. paragraphs 6.3.8 and 6.3.9.

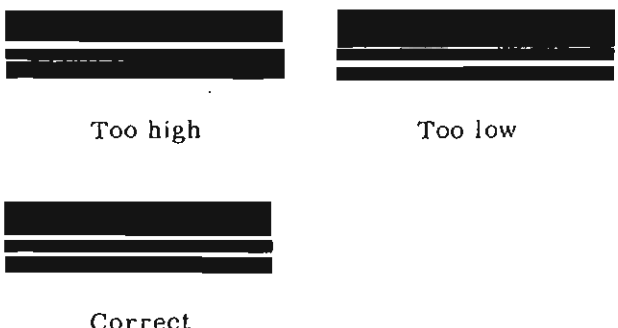

Fig. 6.2 Track measurement of erase head



### 6.5.2 Record/Playback Head

The height position of the record/playback head is aligned by the height adjustment screws, ref. figure 6.0. Record in stereo a 1 000 Hz signal at overloaded recording level (+20 dB) on a full track prerecorded tape. Cut off some of the tape and dip it into a solution of iron powder and alco-

hol (Magna See), and check that the tracks are distributed symmetrically across the tape. Check that the prerecorded zone remains in center of the erased zone. Readjust the erase and record/playback head if necessary. For azimuth and lateral alignment, ref. paragraphs 6.3.4 and 6.3.5.

## 6.6 ELECTRICAL ADJUSTMENTS FOR TANDBERG TAPE RECORDER MODELS 1641X AND 1621X

### 6.6.1 Adjustment of Output Level

Connect a VTVM to each output terminal and play back in stereo Tandberg Test Tape no. 4, 400 Hz at tape speed 7 1/2 ips.

Adjust R146, channel L, and R246, channel R, to 0.75V deflection on the VTVM's.

### 6.6.2 Adjustment of Oscillator Frequency and Bias

### 6.6.3 Using Frequency Meter (Counter)

Connect a frequency meter or counter directly or inductively to the erase head. The degree of coupling depends on input characteristics of the instrument. Adjust C308 until the frequency meter (counter) shows 85.5 kHz.

### 6.6.4 Using Signal Generator and Radio Receiver

Tune the radio to 256.5 kHz (3rd harmonic of 85.5 kHz) and take out a loop from the antenna terminal, 5 cm (2") in diameter and approximately 10 windings. Place the loop close to (around) the erase head. Tune the generator to 256.5 kHz and feed the signal via a similar loop. Start the tape recorder in record mode and adjust C308 until zero beat is obtained.

### 6.6.5 Control of Erase Voltage

Connect a VTVM between yellow wire on the erase head and ground. Apply unscreened test cable or low capacitance probe. Set the tape recorder in record mode and read the meter deflection to 80 - 120V.

Difference in level between mono and stereo recording should be less than 10V.

### 6.6.6 Adjustment of Bias

Connect a VTVM across the bias head. Set the tape recorder in record mode and adjust R301 - channel L (R302 - channel R) to approximately 25V on the VTVM.

### 6.6.7 Preadjustment of Recording Level and Indicator

Connect a signal generator to HIGH INPUT and set the level to 50 mV, 400 Hz. Connect a VTVM, to junction R116 - C108 channel L (R216 - C208 - channel R) and ground. Start the tape recorder in record mode and adjust INPUT LEVEL (R108 channel L - R208 channel R) to 140mV deflection on the VTVM. Then adjust R131 channel L (R231 - channel R) to 0 dB on the indicator.

### 6.6.8 Adjustment of Bias Head

In general this adjustment would only be necessary after changing record/playback head.

Before adjustment of bias head is obtained, paragraph 6.6.2, adjustment of oscillator frequency and bias must be accomplished.

Connect a VTVM across the record/playback head and set to 10V or 3V range. Loosen the fixing screw B approximately 1/2 turn, ref. fig. 6.0. Start the tape recorder in record mode. Check that the tape runs free of flanges on bias head. Adjust screw A until maximum deflection on the VTVM. Set the screw A displacing the bias head towards tape direction until the voltage on VTVM is reduced by 5 - 20%. Then fasten screw B. Demagnetize heads and tape path.

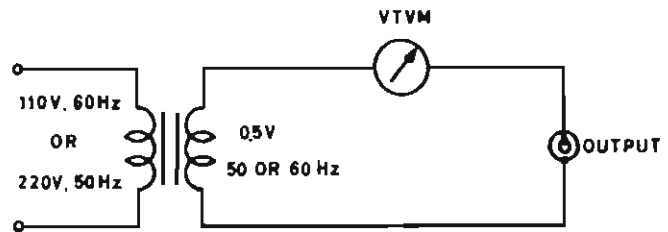

Fig. 6.3

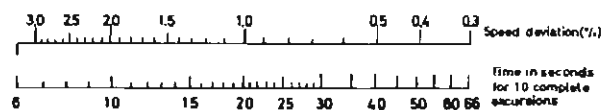

Fig. 6.4

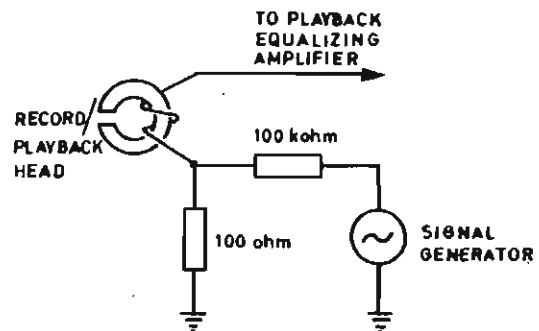

Fig. 6.5

### 6.6.9 Control of Total Frequency Response

The tape recorder's electronic design is fitted and adjusted for Low Noise tape. Consequently, Low Noise tape has to be used for frequency control.

Connect a signal generator to HIGH INPUT and set the level to 500 mV, 400 Hz. Put on a new or erased tape (Low Noise) and start the tape recorder in record mode with the tape speed 3 3/4 ips. Adjust INPUT LEVEL to 0 dB on indicators. Reduce the voltage from signal generator by 30 dB and record the following frequencies: 400 Hz- 5 kHz- 10 kHz- 15 kHz. Play back the tape with VTVM connected to output terminal using 400 Hz signal as 0 dB reference. Check that the frequency response for the whole range is flat, tolerance  $\pm 2.5$  dB. If tolerance is exceeded, the voltage across the bias head has to be successively increased or decreased. Decrease of voltage increases treble, while an increase of voltage decreases the treble. Control the frequency response at all tape speeds.

NOTE: If the bias is adjusted, check distortion according to paragraph 6.6.9.

### 6.6.10 Adjustment of Record Level and Indicator applying Test Tape

Connect a VTVM to each one of the output terminals. Play back test tape no. 4 (400 Hz) at tape speed 7 1/2 ips. Adjust the output level to 0.75V by means of R146, channel L (R246 channel R). Connect a signal generator to HIGH INPUT, insert a new or erased tape (Low Noise) and record a 400 Hz signal with amplitude that gives 1.5 dB above 0.75V level when played back. If necessary, alter between record and playback to obtain correct result. Check that the distortion is between 3 and 5%, ref. paragraph 6.6.11. Adjust R131, channel L (R231, channel R) until indicator reads 0 dB when recording at 3 to 5% distortion level.

### 6.6.11 Distortion

Connect a signal generator 400 Hz, 500 mV, and record the signal on both channels (stereo).

Adjust INPUT LEVEL control until 0 dB deflection on indicators. Rewind the tape and play back in stereo. Distortion shall then be less than 5%. If distortion exceeds 5%, readjust the recording level and indicators, ref. paragraph 6.6.10.

### 6.6.12 Tape Speed Control

#### 1. With Measured Tape Length.

Put on tape measured to 1144 cm (450") and play it back.

Time taken for the whole length should be:

7 1/2 ips: 60 seconds

3 3/4 ips: 120 seconds

1 7/8 ips: 240 seconds.

Tolerance for all tape speeds:  $\pm 1.5\%$ .

#### 2. With Test Tape.

A transformer with secondary voltage 0.5V and a VTVM are connected to OUTPUT terminal as shown in fig. 6.3. Play back test tape no. 10a, if the line frequency is 50 Hz and test tape no. 19a if line frequency is 60 Hz.

Deviation from correct tape speed will give a beat signal across the VTVM. Clock the time for 10 complete excursions of the meter needle. Read the speed deviation in percent corresponding to this particular time from the nomogram below, ref. fig. 6.4.

Speed tolerance:  $\pm 1.5\%$ .

If the tape speed is 3 3/4 ips, and mains frequency 50 Hz, play back test tape no. 10b containing a 50 Hz signal. At mains frequency 60 Hz, play back test tape no. 19b, containing a 60 Hz signal. Proceed as for 7 1/2 ips to find speed accuracy. Tolerance:  $\pm 1.5\%$ .

#### 3. Using Frequency Meter (Counter).

Connect a frequency meter (counter) to output terminal and play back Tandberg Test Tape no. 11, containing a 1 000 Hz signal at tape speed 7 1/2 ips. The frequency meter (counter) indicates directly the speed deviation in % Tape speed tolerance:  $\pm 1.5\%$ .

### 6.6.13 Control of Playback Curves

Insert a 100 ohm resistor in series with upper, channel L (lower, channel R), record/playback head and ground. Connect a signal generator in series with a 100 kohm resistor parallel to the 100 ohm resistor, ref. fig. 6.5. Connect a VTVM and an oscilloscope to output terminal. Control playback curves according to fig. 5.9 at all tape speeds using 400 Hz as reference level.

NOTE: Make sure that the signal is not being clipped by overloading the input. The tolerance is less than  $\pm 2$  dB at all frequencies. Difference in level between the two channels should be less than 4 dB at all frequencies.

### 6.6.14 Control of Recording Curves

Connect a signal generator to HIGH INPUT L (R) and a VTVM to a 100 ohm resistor in series with upper, channel L (lower channel R) record/playback head to ground (black wire). Ref. fig. 6.6. Short-circuit secondary winding of oscillator transformer T301. Set the signal generator to 400 Hz and adjust the level 30 dB below optimum recording level. Start the tape recorder in record position and check the frequency response according to fig. 5.5. Deviation for all frequencies must not exceed  $\pm 2.5$  dB. Difference in level between the two channels should be less than 4 dB at all frequencies. Check the frequency response at all tape speeds.

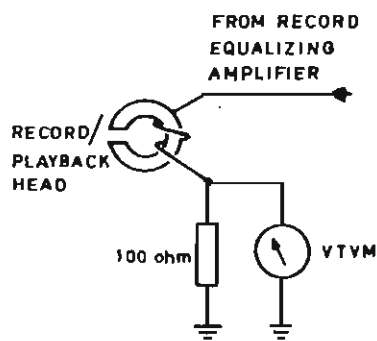

Fig. 6.6

1650X

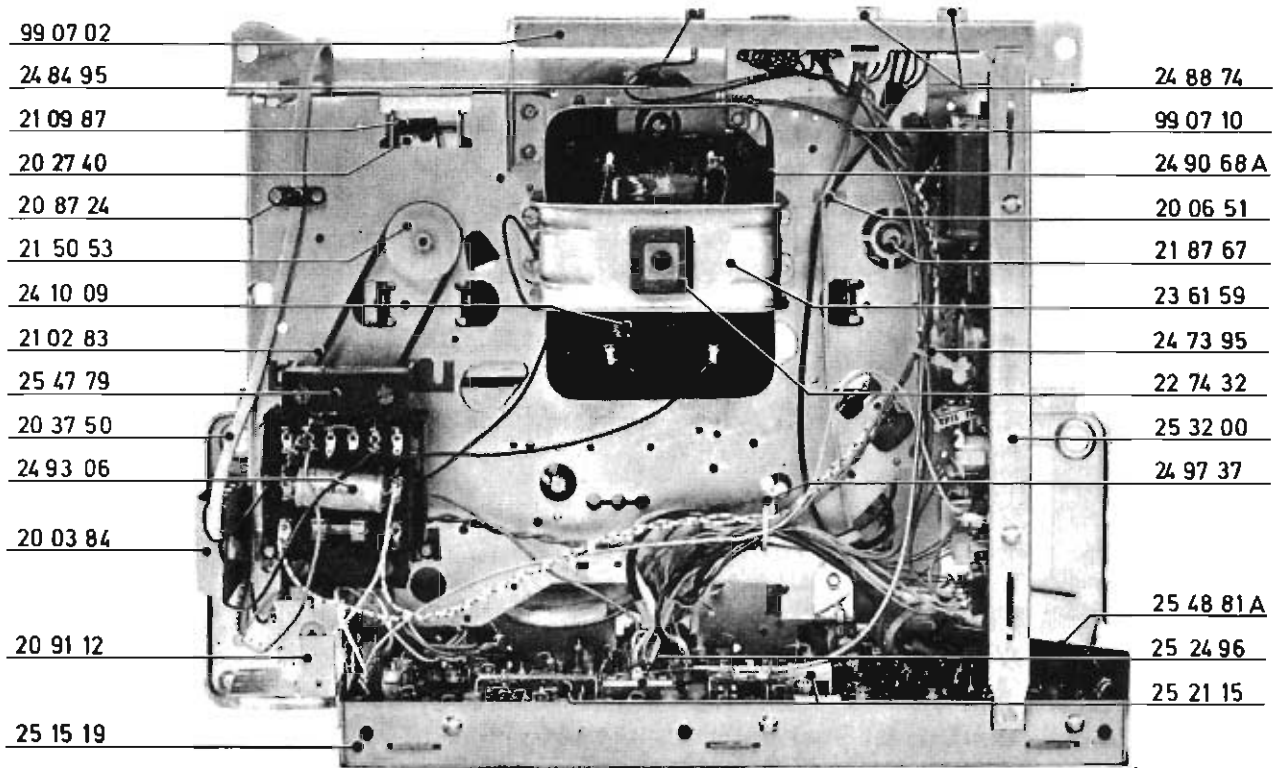

Fig. 6.7 Bottom view of model 1600X

### 6.7 MODIFICATIONS FROM FOUR TRACK TO TWO TRACK VERSION

The following changes have to be introduced when the tape recorder is modified from four-track to two-track.

| Part                 | Four track Model 1641X | Two track Model 1621X | Part      | Four track Model 1641X | Two track Model 1621X |
|----------------------|------------------------|-----------------------|-----------|------------------------|-----------------------|
| Erase head           | 18E                    | 20E                   | R130      | 15 kohm                | 12 kohm               |
| Bias head            | 03B                    | 04B                   | R144      | 120 kohm               | 220 kohm              |
| Record/playback head | 18C                    | 20C                   | R230      | 15 kohm                | 12 kohm               |
| C3                   | 250 pF                 | 400 pF                | R244      | 120 kohm               | 220 kohm              |
| C4                   | 250 pF                 | 400 pF                | R305      | 2.2 kohm               | 1 kohm                |
| C301                 | 3 300 pF               | 3 900 pF              | Q301/Q302 | BC 139/BC 144          | 2N 4921/2N 4918       |
| C302                 | 3 300 pF               | 3 900 pF              | Q303      | BC 147B                | BC 140                |

### 6.8 CONNECTIONS AND MODIFICATIONS FROM 115 - 130 - 230 - 240V AND FROM 50 TO 60 Hz (or 60 to 50 Hz) OPERATION

When changing from 50 to 60 Hz operation, the diameter of the motor pulley is reduced to compensate for the increased mains frequency. The motor pulley and the motor have to be changed.

The transformer, with part number 254779, may be rewired for all above mentioned voltages, while motor has to be changed, see wiring diagram fig. 6.8.

Motor pulley:

- 50 Hz operation, part number: 243940
- 60 Hz operation, part number: 248351B.

Motor:

- 50 Hz operation, part number: 241009
- 60 Hz operation, part number: 254973.

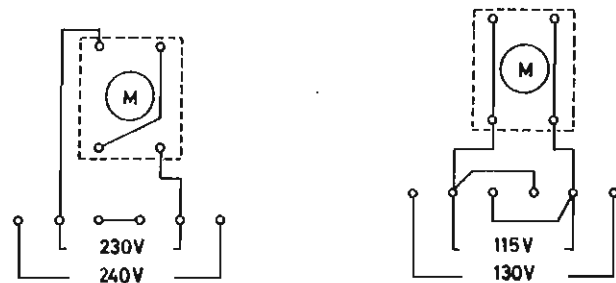

Fig. 6.8 Motor and transformer connections

## 7.0 SPARE PARTS LIST

### Ordering of Parts

When ordering a mechanical part, it is essential that the appropriate part number being used as a reference in this manual, be specified.

For ordering of electrical components, however, the position number (C130, R119, etc.) is used.

Explanation of mechanical parts and electrical component identification

#### Mechanical parts

1. The 6 digit part number specifies the mechanical part.

#### Electrical components

2. The designation 16 C indicates that the component can be used in all models of series 1600X.
3. The designation 164 indicates a component unique for the four track model.
4. The designation 162 indicates a component unique for the two track model.

### Mechanical parts

| Part no. | Description       | Usage                                     | Fig. ref.            | Notes |
|----------|-------------------|---|----------------------|-------|
| 200384   | Insulation shield | Mains switch                              |                      |       |
| 200549   | Flange            | Take-up turntable housing                 | 4.9                  |       |
| 200528   | Housing           |   |                      |       |
| 200651   | Clamp             | Shielded wire (nylon)                     |                      |       |
| 201957   | Shaft             | Arm, pressure pad                         |                      |       |
| 202008   | Mains cord        | 115 V, U.S. version                       |                      |       |
| 202151   | Switch            | Microswitch, motor                        | 4.34                 |       |
| 202303   | Rubber tube       | Shield                                    |                      |       |
| 202309   | Shaft             | Eccentric lever                           |                      |       |
| 202740   | Lever             | Additional friction                       | 4.5, 4.9, 4.10, 4.15 |       |
| 203013   | Washer            | Retaining flywheel bearing                | 4.4, 4.27            |       |
| 203250   | Mains cord, 220 V |   |                      |       |
| 203365   | Shield            | Lamp, revolution counter                  | 4.2, 4.5a            |       |
| 203559   | Spring            | Index lever, trip bar                     |                      |       |
| 203638   | Shaft             | Clutch lever                              | 4.5, 4.14, 4.15      |       |
| 204184   | Mains switch      | ON - OFF                                  | 4.5a                 |       |
| 205671   | Stud              | Parallel arm and cover plate              |                      |       |
| 206017   | Washer            | Rubber top cover                          |                      |       |
| 206296   | Window            | Revolution counter                        | 4.1                  |       |
| 207273   | Spring            | Linkage arm                               | 4.5, 4.5a            |       |
| 207352   | Shaft             | Index lever                               | 4.5                  |       |
| 207625   | Spring            | Clutch lever                              | 4.14, 4.15           |       |
| 207977   | Roller            | Pressure wheel bracket                    | 4.2                  |       |
| 208250   | Bearing           | Selflubricating, flywheel                 | 4.27                 |       |
| 208329   | Cover             | Front, pressure roller arm assembly       | 4.1                  |       |
| 208401   | Spring            | Muting switch                             |                      |       |
| 208724   | Clamp             | Mains cord, fiber                         |                      |       |
| 209112   | Bracket           | Operating lever                           |                      |       |
| 209306   | Spring            | Transfer wheel holder                     | 4.5, 4.25            |       |
| 209385   | Stud              | Eccentric lever                           |                      |       |
| 209816   | Plate             | Guide, speed selector                     | 4.5a, 4.25           |       |
| 210283   | Rubber belt       | Revolution counter                        |                      |       |
| 210987   | Spring            | Lower clutch lever, take-up friction disc | 4.15                 |       |
| 211066   | Shaft             | Forked lever, pressure roller assembly    | 4.4                  |       |
| 211339   | Pulley            | Revolution counter (on counter)           | 4.9                  |       |
| 211418   | Shaft             | Clutch lever                              |                      |       |
| 211612   | Rubber mounting   | Lower                                     |                      |       |
| 212043   | Cover             | Rear trim (heads)                         | 4.1                  |       |

| Part no. | Description           | Usage                                   | Fig. ref.        | Notes |
|----------|-----------------------|---|------------------|-------|
| 212273   | Lever                 | Momentary start/stop, operating         | 4.1, 4.4, 4.28   |       |
| 212747   | Tape guide post       | Left                                    | 4.4, 4.29        |       |
| 212826C  | Forked lever          | Pressure roller assembly                | 4.4, 4.28        |       |
| 213997   | Rubber drive belt     |   | 4.5a, 4.14, 4.15 |       |
| 214155   | Clip                  | Operating lever                         |                  |       |
| 214701   | Spring                | Right friction disc                     | 4.9, 4.15        |       |
| 215053   | Pulley                | Revolution counter (on turntable shaft) |                  |       |
| 215326A  | Rubber mounting       | Upper                                   | 4.1              |       |
| 215405   | Acetal part           | Momentary stop                          | 4.4, 4.28        |       |
| 215556   | Spring                | Pressure roller bracket                 |                  |       |
| 215743   | Mylar disc            | Friction wheel                          | 4.6, 4.8, 4.9    |       |
| 216109   | Rivet                 | Linkage arm                             |                  |       |
| 216461A  | Adjustable tape guide | Middle                                  | 4.4              |       |
| 216734   | Spring                | Speed selector                          | 4.25             |       |
| 217086   | Acetal button         | Clutch levers                           |                  |       |
| 217510   | Spring                | Tape tightening disk                    | 4.6              |       |
| 217869   | Thrust washer         | Lower flywheel bearing                  | 4.27             |       |
| 218415   | Spring                | Left friction disc                      | 4.6, 4.14        |       |
| 218494   | Rivet                 | Parallel arm and trip bar               |                  |       |
| 218767   | Acetal nut            | Hexagon, turntable shaft, (left)        | 4.6              |       |
| 219055   | Switch                | Muting switch                           |                  |       |
| 219198   | Tape tightening disk  |   | 4.6              |       |
| 219234   | Shaft                 | Pressure roller bracket                 |                  |       |
| 219277   | Retainer              | Flywheel bearing                        | 4.4, 4.27, 4.34  |       |
| 219586   | Felt ring             | Flywheel bearing                        | 4.27             |       |
| 219816   | Flange                | Supply turntable housing (acetal)       | 4.6              |       |
| 219823   | Screw                 | Covers                                  | 4.1              |       |
| 220155   | Stud                  | Lifting arm, bias head                  |                  |       |
| 220384   | Revolution counter    |   | 4.5a             |       |
| 220859   | Acetal disk           | Flywheel                                |                  |       |
| 221448B  | Bracket               | Mounting, rear covers                   | 4.4              |       |
| 222044   | "Tandberg" emblem     |   | 4.1              |       |
| 223488   | Connector             | Printed circuit board, 5-pins           |                  |       |
| 225916   | Connector             | Printed circuit board, 7-pins           |                  |       |
| 227432   | Rubber mounting       | Motor                                   |                  |       |
| 228868   | Knob                  | Operating lever                         | 4.1              |       |
| 230629B  | Roller                | Cam disk arm                            |                  |       |
| 234400   | Knob                  | Output selector                         | 4.1              |       |
| 234478   | Spring                | Adjustment screw, bias head             | 4.4              |       |
| 234960   | Washer                | Knob, speed selector                    |                  |       |
| 235549   | Felt strip            | Flywheel                                |                  |       |
| 236159   | Bracket               | Motor                                   |                  |       |
| 236728A  | Cam disc arm          |   | 4.5a, 4.25       |       |
| 238114   | Knob                  | Speed selector                          | 4.1              |       |
| 239738   | Shaft                 | Cam disc, arm                           |                  |       |
| 240276A  | Stud                  | End stop                                | 4.4, 4.34        |       |
| 240377   | Knob                  | Volume control, upper                   | 4.1              |       |
| 240879A  | Plate                 | Transfer wire, equalization switch      |                  |       |
| 241009   | Motor                 | 50 Hz, 110/220 V                        | 4.24             |       |
| 241081   | Ring                  | Potentiometer                           |                  |       |
| 241469   | Spring                | Bias head                               |                  |       |
| 242058   | Knob                  | Volume control, lower                   | 4.1              |       |
| 242244   | Connector             | RADIO                                   |                  |       |
| 242288A  | Lever                 | Bias head                               | 4.4              |       |
| 242309   | Spring                | End stop                                | 4.4, 4.34        |       |
| 242331   | Spring                | Cam disc arm                            | 4.5, 4.5a, 4.25  |       |

1600X

| Part no. | Description         | Usage                           | Fig. ref.             | Notes |
|----------|---------------------|---------------------------------|-----------------------|-------|
| 242503   | Feeler arm          | End stop                        | 4.34                  |       |
| 243013   | Post                | Tape guide, right               | 4.4, 4.34             |       |
| 243150   | Bracket             | Bias head, lever                |                       |       |
| 243925   | Retaining ring      | DIN connector                   |                       |       |
| 243940C  | Motor pulley        | 50 Hz                           | 4.5a, 4.24, 4.25      |       |
| 243990   | Spring              | End stop feeler arm             | 4.34                  |       |
| 244342A  | Lever               | End stop                        | 4.4, 4.34             |       |
| 244694A  | Arm                 | End stop, transfer              | 4.4, 4.34             |       |
| 245297C  | Heat sink           | Rectifier board                 |                       |       |
| 246231   | Plate               | Retainer, wires to motor switch |                       |       |
| 247395   | Clamp               | Wire, 9 mm                      |                       |       |
| 247653   | Tape guide          | Adjustable, outer               | 4.4, 4.29, 4.30       |       |
| 247941   | Shaft               | Pressure roller                 | 4.3, 4.4              |       |
| 248027   | Insulation          | Microswitch                     |                       |       |
| 248157   | Bushing             | Adjustable, tape guide          |                       |       |
| 248186   | Trip bar            |                                 | 4.5, 4.5a, 4.14, 4.15 |       |
| 248351B  | Motor pulley        | 60 Hz                           |                       |       |
| 248495   | Connector           | +26 V                           |                       |       |
| 248638   | Terminal strip      | Heads                           |                       |       |
| 248752A  | Brake block         | Tape brake                      | 4.3, 4.4              |       |
| 248874   | Terminal strip      | w/phono connectors              |                       |       |
| 249068A  | Shielding can       | Motor                           |                       |       |
| 249485   | Insulating plate    | Terminal strip                  |                       |       |
| 249521   | Washer              | Jack, U.S. version              | 4.4                   |       |
| 249551   | Guide               | End stop transfer arm           |                       |       |
| 249630   | Jack                | Microphone, U.S. version        |                       |       |
| 249722   | Meter               | Recording indicator             | 4.1, 4.5a             |       |
| 249737   | Clamp               | Wire, 12.5 mm                   |                       |       |
| 249966   | Spring              | Tape brake                      | 4.3                   |       |
| 250520   | Shaft               | Lifting arm, bias head          | 4.4                   |       |
| 251130   | Transfer lever      | Pressure pad                    | 4.4, 4.29, 4.3, 4.31  |       |
| 251167A  | Lever               | Interlock, push buttons         | 4.4                   |       |
| 251482   | Lever               | Pressure pad                    | 4.4, 4.28             |       |
| 251489A  | Tape guide          | Below pressure pad              |                       |       |
| 251519   | Bracket             | Mounting for main amplifier     |                       |       |
| 251979   | Spacer              | Function selector switch        |                       |       |
| 252115   | Equalization switch |                                 |                       |       |
| 252453   | Set of knobs        |                                 |                       |       |
| 252496   | Linkage             | Equalization switch             |                       |       |
| 252610   | Bracket             | Revolution counter              |                       |       |
| 252848   | Plate               | Guide push buttons              | 4.4                   |       |
| 253092   | Switch              | Push button, function selector  |                       |       |
| 253200   | Supporting bracket  | Osc./rectifier board            |                       |       |
| 253437   | Switch              | Output selector                 | 4.4                   |       |
| 254177   | Push button         | Record, left channel            | 4.1, 4.4              |       |
| 254291   | Plate               | Fixing, revolution counter      | 4.4                   |       |
| 254529   | Spring              | Interlock lever                 |                       |       |
| 254730   | Connector           | Microphone, DIN                 | 4.1, 4.4              |       |
| 254779   | Mains transformer   | 115/230/240 V, No. 720          |                       |       |
| 254844A  | Support             | Pressure pad/tape               | 4.4, 4.29, 4.30       |       |
| 254881A  | Shield              | Main amplifier board            |                       |       |
| 254973   | Motor               | 60 Hz, 110/220 V                |                       |       |
| 255986   | Shield              | Microphone connector            |                       |       |
| 257042   | Cabinet             | Teak                            | 4.1                   |       |
| 257437   | Push button         | Record, right channel           | 4.1, 4.4              |       |
| 258723   | Cabinet             | Rosewood                        | 4.1                   |       |
| 258953   | Top cover plate     |                                 | 4.1                   |       |

| Part no. | Description                           | Usage                            | Fig. ref.                              | Notes |
|----------|---------------------------------------|----------------------------------|--|-------|
| 261999   | Spacer                                | Tube push button assembly        |  |       |
| 262000   | Shaft                                 | Lever, pressure pad              | 4.4                                    |       |
| 262467   | Spring                                | Arm pressure pad                 | 4.4, 4.29, 4.30, 4.31                  |       |
| 264758   | Cabinet                               | Walnut tree                      | 4.1                                    |       |
| 990201   | Lifting arm                           | With pull rod                    | 4.5, 4.5a, 4.25                        |       |
| 990203   | Eccentric segment                     |                                  | 4.2                                    |       |
| 990204   | Parallel arm                          | Complete                         | 4.5, 4.5a, 4.25                        |       |
| 990206   | Mounting arm                          | Transfer wheel                   | 4.5, 4.5a, 4.25                        |       |
| 990207   | Bracket                               | Front trim cover, left           |  |       |
| 990208   | Bracket                               | Front trim cover, right          |  |       |
| 990209   | Thrust spring                         | With acetal knob                 | 4.4                                    |       |
| 990213   | Holder                                | Transfer wheel                   | 4.5a                                   |       |
| 990214   | Cover plate 1                         |                                  | 4.5a                                   |       |
| 990215   | Cover plate 2                         |                                  | 4.5a                                   |       |
| 990217   | Bracket w/shaft                       | Momentary stop                   | 4.4                                    |       |
| 990222   | Spring washer                         | Upper flywheel bearing           | 4.27, 4.34                             |       |
| 990223   | Retainer                              | Upper flywheel bearing, threaded | 4.27                                   |       |
| 990225   | Operating lever shaft                 | with acetal ball                 | 4.5a                                   |       |
| 990226   | Supply turntable                      | (Left)                           | 4.5a, 4.6, 4.14, 4.25                  |       |
| 990227   | Take-up turntable                     | (Right)                          | 4.5a, 4.9, 4.15, 4.25                  |       |
| 990228   | Clutch                                | Supply friction disk             | 4.5, 4.6, 4.7, 4.14                    |       |
| 990229   | Upper clutch lever                    | Take up friction disk            | 4.5, 4.9, 4.10, 4.15                   |       |
| 990230   | Index lever                           | Trip bar                         | 4.5, 4.5a                              |       |
| 990232   | Momentary start/stop                  | Assembly                         |  |       |
| 990233   | Transfer wheel                        |                                  | 4.5, 4.5a, 4.24, 4.25                  |       |
| 990234   | Pressure roller                       |                                  | 4.3, 4.4                               |       |
| 990235   | Bracket w/shaft                       | End stop                         | 4.4                                    |       |
| 990236   | Friction disk                         | Left and right                   | 4.6, 4.7, 4.8, 4.9, 4.10<br>4.14, 4.15 |       |
| 990238   | Spring, shaft                         | Pressure roller                  | 4.3                                    |       |
| 990302   | Pressure roller arm                   | Assembly                         | 4.4                                    |       |
| 990312   | Flywheel                              | Complete                         | 4.5a, 4.25, 4.27, 4.34                 |       |
| 990319   | Brake                                 | Flywheel, complete               |  |       |
| 990325   | Pressure pad                          |                                  | 4.4, 4.29, 4.30, 4.31                  |       |
| 990330   | Cam disk w./shaft                     |                                  | 4.5, 4.5a, 4.25                        |       |
| 990700   | Main amplifier board                  | Complete                         |  |       |
| 990701   | Oscillator and rectifier board        | Complete                         |  |       |
| 990702   | Input amplifier board                 | Complete                         | 4.5a                                   |       |
| 990703   | Oscillator and rectifier board        | Complete                         |  |       |
| 990704   | Main amplifier board                  | Complete                         |  |       |
| 990710   | Transfer wire                         | Equalization switch              |  |       |
| 990711   | Additional oscillator amplifier board |                                  |  |       |
| 991025   | Housing                               | With bearing                     | 4.5, 4.6, 4.9                          |       |

### Screws, Washers and Circlips

| Article | Part no. | Ref. no. | Dimension   | Type      |
|---------|----------|----------|-------------|-----------|
| Screw   | 217984   | M121     | 2.3 x 12 mm | DIN 84-4D |
| Screw   | 214270   | M120     | 2.6 x 4 mm  | DIN 84-4D |
| Screw   | 200556   | M140     | 3 x 3 mm    | DIN 84-4D |
| Screw   | 206842   | M101     | 3 x 4 mm    | DIN 84-4D |
| Screw   | 208372   | M102     | 3 x 4.5 mm  | DIN 84-4D |
| Screw   | 216951   | M103     | 3 x 5 mm    | DIN 84-4D |
| Screw   | 208523   | M104     | 3 x 6 mm    | DIN 84-4D |
| Screw   | 204809   | M107     | 3 x 8 mm    | DIN 84-4D |
| Screw   | 223186   | M148     | 3 x 8 mm    | DIN 7988  |

| Article       | Part no. | Ref. no. | Dimension          | Type      |
|---------------|----------|----------|--------------------|-----------|
| Screw         | 210622   | M110     | 3 x 18 mm          | DIN 84-4D |
| Screw         | 244837   | M129     | 4 x 24 mm          | DIN 7985  |
| Screw         | 220169   | M173     | 3/16" No. 4        |           |
| Screw         | 200944   | M116     | 1/4" No. 4         |           |
| Screw         | 218675   | M154     | 3/8" No. 4         |           |
| Cireclip      | 236346   | M360     | 2 mm               |           |
| Cireclip      | 230542   | M359     | 2.3 mm             | DIN 6799  |
| Cireclip      | 262000   | M314     | 3 mm               |           |
| Cireclip      | 239651   | M321     | 3.2 mm             | DIN 6799  |
| Cireclip      | 235937   | M316     | 4 mm               | DIN 6799  |
| Cireclip      | 235600   | M317     | 5 mm               | DIN 6799  |
| Cireclip      | 213826   | M318     | 6 mm               | DIN 6799  |
| Turbax washer | 214141   | M301     | 7.5 x 4.2 x 0.2 mm |           |
| Turbax washer | 214895   | M302     | 7.5 x 4.2 x 0.3 mm |           |
| Turbax washer | 204013   | M303     | 7.5 x 4.2 x 0.5 mm |           |
| Turbax washer | 217856   | M361     | 7.5 x 5.2 x 0.2 mm |           |
| Turbax washer | 200299   | M304     | 7.5 x 5.2 x 0.5 mm |           |

## Electrical components

### Capacitors

| Ref. no.    | Description   |      |      | Type          | Notes                           |
|-------------|---------------|------|------|---------------|---------------------------------|
| C1 - 16 C   | 68 pF         | 500V | 10%  | Ceramic       |                                 |
| C2 - 16 C   | 68 pF         | 500V | 10%  | Ceramic       |                                 |
| C3 - 162    | 400 pF        | 160V | 2.5% | Polyester     |                                 |
| C3 - 164    | 250 pF        | 630V | 2.5% | Polyester     |                                 |
| C4 - 162    | 400 pF        | 160V | 2.5% | Polyester     |                                 |
| C4 - 164    | 250 pF        | 630V | 2.5% | Polyester     |                                 |
| C101 - 16 C | 25 $\mu$ F    | 25V  |      | Electrolytic  |                                 |
| C102 - 16 C | 100 $\mu$ F   | 25V  |      | Electrolytic  |                                 |
| C103 - 16 C | 25 $\mu$ F    | 25V  |      | Electrolytic  |                                 |
| C104 - 16 C | 2 $\mu$ F     | 100V |      | Electrolytic  |                                 |
| C105 - 16 C | 0.22 $\mu$ F  | 200V | 10%  | Met. paper    |                                 |
| C106 - 16 C | 470 pF        | 500V | 20%  | Ceramic       |                                 |
| C107 - 16 C | 2 $\mu$ F     | 100V |      | Electrolytic  |                                 |
| C108 - 16 C | 2 $\mu$ F     | 100V |      | Electrolytic  |                                 |
| C109 - 16 C | 25 $\mu$ F    | 25V  |      | Electrolytic  |                                 |
| C110 - 16 C | 470 pF        | 500V | 20%  | Ceramic       |                                 |
| C111 - 16 C | 2 $\mu$ F     | 100V |      | Electrolytic  |                                 |
| C112 - 16 C | 2 $\mu$ F     | 100V |      | Electrolytic  |                                 |
| C113 - 16 C | 25 $\mu$ F    | 25V  |      | Electrolytic  |                                 |
| C114 - 16 C | 0.22 $\mu$ F  | 200V | 10%  | Met. paper    |                                 |
| C115 - 16 C | 0.022 $\mu$ F | 400V | 5%   | Met. paper    |                                 |
| C116 - 16 C | 0.068 $\mu$ F | 250V | 10%  | Polyester     | Changed from ser. no. 2 700 551 |
| C117 - 16 C | 0.022 $\mu$ F | 400V | 5%   | Met. paper    |                                 |
| C119 - 16 C | 0.01 $\mu$ F  | 400V | 10%  | Met. paper    |                                 |
| C120 - 16 C | 0.01 $\mu$ F  | 400V | 10%  | Met. paper    |                                 |
| C121 - 16 C | 280 pF        | 125V | 5%   | Styroflex     |                                 |
| C122 - 16 C | 470 pF        | 125V | 5%   | Styroflex     |                                 |
| C123 - 16 C | 3 300 pF      | 63V  | 2%   | Styroflex     | Changed from ser. no. 2 700 551 |
| C124 - 16 C | 2 $\mu$ F     | 100V |      | Electrolytic  |                                 |
| C125 - 16 C | 25 $\mu$ F    | 25V  |      | Electrolytic  |                                 |
| C126 - 16 C | 470 pF        | 500V | 20%  | Ceramic       |                                 |
| C127 - 16 C | 0.022 $\mu$ F | 400V | 10%  | Met. paper    |                                 |
| C128 - 16 C | 2 $\mu$ F     | 100V |      | Electrolytic  |                                 |
| C129 - 16 C | 470 pF        | 500V | 20%  | Ceramic       |                                 |
| C130 - 16 C | 100 $\mu$ F   | 25V  |      | Electrolytic  |                                 |
| C132 - 16 C | 0.1 $\mu$ F   | 100V | 10%  | Polycarbonate |                                 |



Capacitors cont.

| Ref. no.    | Description |                    | Type              | Notes                                |
|-------------|-------------|--------------------|-------------------|--------------------------------------|
| C133 - 16 C | 470 pF      | 500V               | Electrolytic      |                                      |
| C134 - 16 C | 25 μF       | 25V                | Electrolytic      |                                      |
| C135 - 16 C | 470 pF      | 500V               | 20% Ceramic       |                                      |
| C136 - 16 C | 2 μF        | 100V               | Electrolytic      |                                      |
| C137 - 16 C | 470 pF      | 500V               | 20% Ceramic       |                                      |
| C138 - 16 C | 2 μF        | 100V               | Electrolytic      | Introduced from serial no. 2 703 521 |
| C201 - 16 C | 25 μF       | 25V                | Electrolytic      |                                      |
| C202 - 16 C | 100 μF      | 250V               | Electrolytic      |                                      |
| C203 - 16 C | 25 μF       | 25V                | Electrolytic      |                                      |
| C204 - 16 C | 2 μF        | 100V               | Electrolytic      |                                      |
| C205 - 16 C | 0.22 μF     | 200V               | 10% Met. paper    |                                      |
| C206 - 16 C | 470 pF      | 500V               | 20% Ceramic       |                                      |
| C207 - 16 C | 2 μF        | 100V               | Electrolytic      |                                      |
| C208 - 16 C | 2 μF        | 100V               | Electrolytic      |                                      |
| C209 - 16 C | 25 μF       | 25V                | Electrolytic      |                                      |
| C210 - 16 C | 470 pF      | 500V               | 20% Ceramic       |                                      |
| C211 - 16 C | 2 μF        | 100V               | Electrolytic      |                                      |
| C212 - 16 C | 2 μF        | 100V               | Electrolytic      |                                      |
| C213 - 16 C | 25 μF       | 25V                | Electrolytic      |                                      |
| C214 - 16 C | 0.22 μF     | 200V               | 10% Met. paper    |                                      |
| C215 - 16 C | 0.022 μF    | 400V               | 5% Met. paper     |                                      |
| C216 - 16 C | 0.068 μF    | 250V               | 10% Polyester     | Changed from ser. no. 2 703 952      |
| C217 - 16 C | 0.022 μF    | 400V               | 5% Met. paper     |                                      |
| C219 - 16 C | 0.01 μF     | 400V               | 10% Met. paper    |                                      |
| C220 - 16 C | 0.01 μF     | 400V               | 10% Met. paper    |                                      |
| C221 - 16 C | 680 pF      | 125V               | 5% Polyester      |                                      |
| C222 - 16 C | 470 pF      | 125V               | 5% Polyester      |                                      |
| C223 - 16 C | 3 300 pF    | 63V                | 2% Polyester      | Changed from ser. no. 2 700 551      |
| C224 - 16 C | 2 μF        | 100V               | Electrolytic      |                                      |
| C225 - 16 C | 25 μF       | 25V                | Electrolytic      |                                      |
| C226 - 16 C | 470 pF      | 500V               | 20% Ceramic       |                                      |
| C227 - 16 C | 0.022 μF    | 400V               | 10% Met. paper    |                                      |
| C228 - 16 C | 2 μF        | 100V               | Electrolytic      |                                      |
| C229 - 16 C | 470 pF      | 500V               | 20% Ceramic       |                                      |
| C230 - 16 C | 100 μF      | 25V                | Electrolytic      |                                      |
| C232 - 16 C | 0.1 μF      | 100V               | 10% Polycarbonate |                                      |
| C233 - 16 C | 470 pF      | 500V               | 20% Ceramic       |                                      |
| C234 - 16 C | 25 μF       | 25V                | Electrolytic      |                                      |
| C235 - 16 C | 470 pF      | 500V               | 20% Ceramic       |                                      |
| C236 - 16 C | 2 μF        | 100V               | Electrolytic      |                                      |
| C238 - 16 C | 2 μF        | 100V               | Electrolytic      | Introduced from s. no. 2 703 521     |
| C301 - 162  | 3 900 pF    | 64V                | 2% Polyester      |                                      |
| C301 - 164  | 3 300 pF    | 64V                | 2% Polyester      |                                      |
| C302 - 162  | 3 900 pF    | 64V                | 2% Polyester      |                                      |
| C302 - 164  | 3 300 pF    | 64V                | 2% Polyester      |                                      |
| C303 - 16 C | 1 μF        | 100V               | 20% Polycarbonate |                                      |
| C304 - 16 C | 0.1 μF      | 200V               | 10% Met. paper    |                                      |
| C305 - 16 C | 180 pF      | 500V               | 10% Ceramic       |                                      |
| C306 - 16 C | 25 μF       | 25V                | Electrolytic      |                                      |
| C307 - 16 C | 820 pF      | 63V                | 5% Polyester      |                                      |
| C308 - 16 C | 150-750 pF  | Trimming capacitor |                   |                                      |
| C309 - 16 C | 0.01 μF     | 63V                | 5% Polyester      |                                      |
| C310 - 16 C | 0.01 μF     | 63V                | 5% Polyester      |                                      |
| C311 - 16 C | 100 μF      | 40V                | Electrolytic      |                                      |
| C313 - 16 C | 1 000 μF    | 55/60V             | Electrolytic      |                                      |
| C314 - 16 C | 0.1 μF      | 200V               | 10% Met. paper    |                                      |
| C315 - 16 C | 0.1 μF      | 200V               | 10% Met. paper    |                                      |
| C316 - 16 C | 180 pF      | 500V               | 10% Ceramic       |                                      |

# Resistors

| Ref. no.    | Description |                       |     | Notes                             |
|-------------|-------------|-----------------------|-----|-----------------------------------|
| R1 - 16 C   | 1 Mohm      | 1/4W                  | 5%  |                                   |
| R2 - 16 C   | 47 kohm     | 1/4W                  | 5%  |                                   |
| R3 - 16 C   | 1 Mohm      | 1/4W                  | 5%  |                                   |
| R4 - 16 C   | 47 kohm     | 1/4W                  | 5%  |                                   |
| R101 - 16 C | 1 kohm      | 1/3W                  | 5%  |                                   |
| E102 - 16 C | 470 ohm     | 1/3W                  | 5%  |                                   |
| R103 - 16 C | 82 kohm     | 1/3W                  | 5%  |                                   |
| R104 - 16 C | 120 kohm    | 1/3W                  | 5%  |                                   |
| R105 - 16 C | 470 kohm    | 1/3W                  | 10% |                                   |
| R106 - 16 C | 10 kohm     | 1/3W                  | 10% |                                   |
| R107 - 16 C | 1 kohm      | 1/3W                  | 5%  |                                   |
| R108 - 16 C | 1x10 kohm   | Pot. meter, pos. log. |     |                                   |
| R109 - 16 C | 47 kohm     | 1/3W                  | 5%  | Changed from serial no. 2 705 440 |
| R110 - 16 C | 5.6 kohm    | 1/3W                  | 5%  |                                   |
| R111 - 16 C | 68 kohm     | 1/3W                  | 5%  |                                   |
| R112 - 16 C | 1 Mohm      | 1/3W                  | 5%  |                                   |
| R113 - 16 C | 10 kohm     | 1/3W                  | 5%  |                                   |
| R114 - 16 C | 680 ohm     | 1/3W                  | 5%  |                                   |
| R115 - 16 C | 2 kohm      | 1/3W                  | 10% |                                   |
| R116 - 16 C | 1 kohm      | 1/3W                  | 10% |                                   |
| R117 - 16 C | 10 kohm     | 1/3W                  | 10% |                                   |
| R118 - 16 C | 680 ohm     | 1/3W                  | 10% |                                   |
| R119 - 16 C | 82 kohm     | 1/3W                  | 10% |                                   |
| R120 - 16 C | 1.5 kohm    | 1/3W                  | 5%  |                                   |
| R121 - 16 C | 220 kohm    | 1/3W                  | 5%  |                                   |
| R122 - 16 C | 1 kohm      | 1/3W                  | 10% |                                   |
| R123 - 16 C | 10 kohm     | 1/3W                  | 10% |                                   |
| R124 - 16 C | 1 kohm      | 1/3W                  | 10% |                                   |
| R125 - 16 C | 15 kohm     | 1/2W                  | 10% |                                   |
| R126 - 16 C | 2.7 kohm    | 1/4W                  | 5%  |                                   |
| R127 - 16 C | 820 ohm     | 1/3W                  | 5%  |                                   |
| R128 - 16 C | 820 ohm     | 1/3W                  | 5%  |                                   |
| R129 - 16 C | 120 ohm     | 1/3W                  | 10% | Changed from serial no. 2 703 952 |
| R130 - 162  | 12 kohm     | 1/3W                  | 5%  |                                   |
| R130 - 164  | 15 kohm     | 1/3W                  | 5%  |                                   |
| R131 - 16 C | 47 ohm      | Pot. meter, linear    |     |                                   |
| R132 - 16 C | 1 Mohm      | 1/3W                  | 10% |                                   |
| R133 - 16 C | 15 kohm     | 1/3W                  | 10% |                                   |
| R134 - 16 C | 4.7 kohm    | 1/4W                  | 10% |                                   |
| R135 - 16 C | 120 ohm     | 1/3W                  | 5%  |                                   |
| R136 - 16 C | 680 ohm     | 1/3W                  | 5%  |                                   |
| R137 - 16 C | 220 kohm    | 1/3W                  | 5%  |                                   |
| R138 - 16 C | 1 kohm      | 1/3W                  | 10% |                                   |
| R139 - 16 C | 68 kohm     | 1/3W                  | 5%  |                                   |
| R140 - 16 C | 10 kohm     | 1/3W                  | 5%  |                                   |
| R141 - 16 C | 10 kohm     | 1/3W                  | 5%  |                                   |
| R142 - 16 C | 2.7 kohm    | 1/3W                  | 5%  | Changed from serial no. 2 706 790 |
| R143 - 16 C | 4.7 kohm    | 1/3W                  | 5%  |                                   |
| R144 - 162  | 220 kohm    | 1/3W                  | 5%  |                                   |
| R144 - 164  | 120 kohm    | 1/3W                  | 5%  | Changed from serial no. 2 700 551 |
| R145 - 16 C | 1 kohm      | 1/3W                  | 5%  |                                   |
| R146 - 16 C | 10 kohm     | Pot. meter, linear    |     |                                   |
| R147 - 16 C | 68 kohm     | 1/3W                  | 10% |                                   |
| R148 - 16 C | 680 ohm     | 1/3W                  | 10% |                                   |
| R149 - 16 C | 220 kohm    | 1/3W                  | 5%  |                                   |
| R150 - 16 C | 1.5 kohm    | 1/3W                  | 10% |                                   |
| R151 - 16 C | 10 kohm     | 1/3W                  | 10% |                                   |
| R152 - 16 C | 22 kohm     | 1/3W                  | 10% |                                   |

## Resistors cont.

| Ref. no.    | Description |                       |     | Notes                             |
|-------------|-------------|-----------------------|-----|-----------------------------------|
| R153 - 16 C | 1 kohm      | 1/3W                  | 10% |                                   |
| R154 - 16 C | 270 kohm    | 1/3W                  | 10% |                                   |
| R155 - 16 C | 100 ohm     | 1/2W                  | 10% |                                   |
| R156 - 16 C | 330 ohm     | 1/3W                  | 10% |                                   |
| R157 - 16 C | 680 ohm     | 1/3W                  | 5%  |                                   |
| R158 - 16 C | 3.6 kohm    | 1/4W                  | 5%  |                                   |
| R159 - 16 C | 100 ohm     | 1/3W                  | 5%  |                                   |
| R201 - 16 C | 1 kohm      | 1/3W                  | 5%  |                                   |
| R202 - 16 C | 470 ohm     | 1/3W                  | 5%  |                                   |
| R203 - 16 C | 82 kohm     | 1/3W                  | 5%  |                                   |
| R204 - 16 C | 120 kohm    | 1/3W                  | 5%  |                                   |
| R205 - 16 C | 470 ohm     | 1/3W                  | 10% |                                   |
| R206 - 16 C | 10 kohm     | 1/3W                  | 10% |                                   |
| R207 - 16 C | 1 kohm      | 1/3W                  | 5%  |                                   |
| R208 - 16 C | 1x10 kohm   | Pot. meter, pos. log. |     |                                   |
| R209 - 16 C | 47 kohm     | 1/3W                  | 10% | Changed from serial no. 2 705 440 |
| R210 - 16 C | 5.6 kohm    | 1/3W                  | 5%  |                                   |
| R211 - 16 C | 68 kohm     | 1/3W                  | 5%  |                                   |
| R212 - 16 C | 1 Mohm      | 1/3W                  | 5%  |                                   |
| R213 - 16 C | 10 kohm     | 1/3W                  | 5%  |                                   |
| R214 - 16 C | 680 ohm     | 1/3W                  | 5%  |                                   |
| R215 - 16 C | 2 kohm      | 1/3W                  | 10% |                                   |
| R216 - 16 C | 1 kohm      | 1/3W                  | 10% |                                   |
| R217 - 16 C | 10 kohm     | 1/3W                  | 10% |                                   |
| R218 - 16 C | 680 ohm     | 1/3W                  | 10% |                                   |
| R219 - 16 C | 82 kohm     | 1/3W                  | 10% |                                   |
| R220 - 16 C | 1.5 kohm    | 1/3W                  | 5%  |                                   |
| R221 - 16 C | 220 kohm    | 1/3W                  | 5%  |                                   |
| R222 - 16 C | 1 kohm      | 1/3W                  | 10% |                                   |
| R223 - 16 C | 10 kohm     | 1/3W                  | 10% |                                   |
| R224 - 16 C | 1 kohm      | 1/3W                  | 10% |                                   |
| R225 - 16 C | 15 kohm     | 1/2W                  | 10% |                                   |
| R226 - 16 C | 2.7 kohm    | 1/4W                  | 5%  |                                   |
| R227 - 16 C | 820 ohm     | 1/3W                  | 5%  |                                   |
| R228 - 16 C | 820 ohm     | 1/3W                  | 5%  |                                   |
| R229 - 16 C | 220 ohm     | 1/3W                  | 10% | Changed from serial no. 2 703 952 |
| R230 - 162  | 12 kohm     | 1/3W                  | 5%  |                                   |
| R230 - 164  | 15 kohm     | 1/3W                  | 5%  |                                   |
| R231 - 16 C | 47 kohm     | Pot. meter, linear    |     |                                   |
| R232 - 16 C | 1 Mohm      | 1/3W                  | 10% |                                   |
| R233 - 16 C | 15 kohm     | 1/3W                  | 10% |                                   |
| R234 - 16 C | 4.7 kohm    | 1/3W                  | 10% |                                   |
| R235 - 16 C | 120 ohm     | 1/3W                  | 5%  |                                   |
| R236 - 16 C | 680 ohm     | 1/3W                  | 5%  |                                   |
| R237 - 16 C | 220 kohm    | 1/3W                  | 5%  |                                   |
| R238 - 16 C | 1 kohm      | 1/3W                  | 10% |                                   |
| R239 - 16 C | 68 kohm     | 1/3W                  | 5%  |                                   |
| R240 - 16 C | 10 kohm     | 1/3W                  | 5%  |                                   |
| R241 - 16 C | 10 kohm     | 1/3W                  | 5%  |                                   |
| R242 - 16 C | 2.7 kohm    | 1/3W                  | 5%  | Changed from serial no. 2 706 790 |
| R243 - 16 C | 4.7 kohm    | 1/3W                  | 5%  |                                   |
| R244 - 16 C | 120 kohm    | 1/3W                  | 5%  | Changed from serial no. 2 700 551 |
| R245 - 16 C | 1 kohm      | 1/3W                  | 10% |                                   |
| R246 - 16 C | 10 kohm     | Pot. meter, linear    |     |                                   |
| R247 - 16 C | 68 kohm     | 1/3W                  | 10% |                                   |
| R248 - 16 C | 690 ohm     | 1/3W                  | 10% |                                   |
| R249 - 16 C | 220 kohm    | 1/3W                  | 5%  |                                   |
| R250 - 16 C | 1.5 kohm    | 1/3W                  | 10% |                                   |
| R251 - 16 C | 10 kohm     | 1/3W                  | 10% |                                   |

## Resistors

| Ref no.     | Description |                    |     | Notes                             |
|-------------|-------------|--------------------|-----|-----------------------------------|
| R252 - 16 C | 22 kohm     | 1/4W               | 5%  |                                   |
| R253 - 16 C | 1 kohm      | 1/3W               | 10% |                                   |
| R254 - 16 C | 270 ohm     | 1/3W               | 10% |                                   |
| R255 - 16 C | 100 ohm     | 1/2W               | 10% |                                   |
| R256 - 16 C | 330 ohm     | 1/3W               | 10% |                                   |
| R257 - 16 C | 680 ohm     | 1/3W               | 5%  |                                   |
| R258 - 16 C | 3.6 kohm    | 1/4W               | 5%  |                                   |
| R259 - 16 C | 100 ohm     | 1/3W               | 10% |                                   |
| R301 - 16 C | 18 kohm     | Pot. meter, linear |     | Changed from serial no. 2 707 340 |
| R302 - 16 C | 18 kohm     | Pot. meter, linear |     | Changed from serial no. 2 707 340 |
| R303 - 16 C | 4.7 ohm     | 1/2W               | 5%  |                                   |
| R304 - 16 C | 4.7 ohm     | 1/2W               | 5%  |                                   |
| R305 - 162  | 1 kohm      | 1/3W               | 10% |                                   |
| R305 - 164  | 2.2 kohm    | 1/3W               | 10% |                                   |
| R306 - 16 C | 47 kohm     | 1/3W               | 10% |                                   |
| R307 - 16 C | 33 kohm     | 1/3W               | 10% |                                   |
| R308 - 16 C | 220 ohm     | 1/3W               | 5%  |                                   |
| R309 - 16 C | 220 ohm     | 1/3W               | 5%  |                                   |
| R310 - 16 C | 2.7 kohm    | 1/3W               | 10% | Changed from serial no. 2 701 210 |
| R311 - 16 C | 2.7 kohm    | 1/3W               | 10% | Changed from serial no. 2 701 210 |
| R312 - 16 C | 2.2 Mohm    | 1/3W               | 10% |                                   |
| R313 - 16 C | 2.2 Mohm    | 1/3W               | 10% |                                   |
| R314 - 16 C | 100 ohm     | 1/3W               | 10% |                                   |
| R315 - 16 C | 1 kohm      | 1/3W               | 10% |                                   |
| R316 - 16 C | 3.3 kohm    | 1/3W               | 10% |                                   |
| R317 - 16 C | 39 kohm     | 1/3W               | 10% |                                   |
| R318 - 16 C | 68 ohm      | 1/3W               | 10% |                                   |
| R319 - 16 C | 1.5 kohm    | 1W                 | 5%  |                                   |
| R320 - 16 C | 680 ohm     | 1W                 | 10% |                                   |
| R321 - 16 C | 680 ohm     | 1W                 | 10% |                                   |

## Transistors

| Ref. no.    | Description | Notes |
|-------------|-------------|-------|
| Q101 - 16 C | BC 149B     |       |
| Q102 - 16 C | BC 149B     |       |
| Q103 - 16 C | BC 149B     |       |
| Q104 - 16 C | BC 147B     |       |
| Q105 - 16 C | BC 148A     |       |
| Q106 - 16 C | BC 148A     |       |
| Q107 - 16 C | BC 107B     |       |
| Q108 - 16 C | BC 147B     |       |
| Q109 - 16 C | BC 149B     |       |
| Q110 - 16 C | BC 149A     |       |
| Q111 - 16 C | BC 107B     |       |
| Q112 - 16 C | BC 148A     |       |
| Q113 - 16 C | BC 148A     |       |
| Q114 - 16 C | BC 107B     |       |
| Q201 - 16 C | BC 149B     |       |
| Q202 - 16 C | BC 149B     |       |
| Q203 - 16 C | BC 149B     |       |
| Q204 - 16 C | BC 147B     |       |
| Q205 - 16 C | BC 148A     |       |
| Q206 - 16 C | BC 148A     |       |
| Q207 - 16 C | BC 107B     |       |
| Q208 - 16 C | BC 147B     |       |
| Q209 - 16 C | BC 149B     |       |

1600K

Transistors cont.

| Ref. no.      | Description                   | Notes  |
|---------------|-------------------------------|--|
| Q210 - 16 C   | BC 149B                       | <p>Relevant transistors viewed from underneath</p> |
| Q211 - 16 C   | BC 107B                       |  |
| Q212 - 16 C   | BC 148A                       |  |
| Q213 - 16 C   | BC 148A                       |  |
| Q214 - 16 C   | BC 107B                       |  |
| Q301/Q302-162 | 2N 4921/2N 4918               |  |
| Q301/Q302-164 | BC 139/BC 144 - BC 160/BC 140 |  |
| Q303 - 162    | BC 140                        |  |
| Q303 - 164    | BC 147B                       |  |
| Q304 - 16 C   | BC 147B                       |  |
| Q305 - 16 C   | BC 147B                       |  |
| Q306 - 16 C   | BC 147B                       |  |
| Q307 - 16 C   | BC 107B                       |  |
| Q308 - 16 C   | AUY 21                        |  |

Diodes

| Ref. no.    | Description   | Notes                                |
|-------------|---------------|--------------------------------------|
| D301 - 16 C | 1N 4148       | Introduced from serial no. 2 710 620 |
| D303 - 16 C | 1N 4148       |                                      |
| D304 - 16 C | 1N 4148       |                                      |
| D305 - 16 C | ZF 27 (Zener) |                                      |
| D306 - 16 C | 1N 4148       |                                      |

Potentiometers

| Ref. no.         | Description | Type     | Notes |
|------------------|-------------|----------|-------|
| R108/R208 - 16 C | 2 x 10 kohm | Pos. log |       |
| R131 - 16 C      | 47 kohm     | Linear   |       |
| R146 - 16 C      | 10 kohm     | Linear   |       |
| R231- 16 C       | 47 kohm     | Linear   |       |
| R246 - 16 C      | 10 kohm     | Linear   |       |
| R301 - 16 C      | 18 kohm     | Linear   |       |
| R302 - 16 C      | 18 kohm     | Linear   |       |

Rectifier

| Ref. no. | Description | Notes |
|----------|-------------|-------|
|          | B40 C2 200  |       |

Trimming Capacitor

| Ref. no.    | Description  | Notes |
|-------------|--------------|-------|
| C308 - 16 C | 150 - 750 pF |       |

Transformer

| Ref. no.          | Description            | Notes |
|-------------------|------------------------|-------|
| T301 - 16 C       | Oscillator transformer |       |
| Mains transformer | Type 720               |       |

1600x  
Heads

| Previous Designation | Usage                | New Designation |
|----------------------|----------------------|-----------------|
| 67 H - 164           | Record/playback head | 18C - 164       |
| 68 H - 164           | Bias head            | 03B - 164       |
| 70 H - 164           | Erase head           | 18E - 164       |
| 75 H - 162           | Erase head           | 10E - 162       |
| 76 H - 162           | Record/playback head | 20C - 162       |
| 77 H - 162           | Bias head            | 04B - 162       |

Explanation of Head Type Code:

C - Combined Record/Playback Head, B - Bias Head (Crossfield), E - Erase Head. The letter indicates the type of head while preceding digits represents the serial number.

### LUBRICATING

The motor:

The motor should be lubricated after approx. every 3000 hours of use.

The upper and the lower bearing should be lubricated with a Teresso oil 43 or 47 from Esso.

The self-lubricating bearings:

The turntables, the flywheel, and the speed transfer wheel are mounted in self-lubricating bearings and should usually not be lubricated. If, however, it should be necessary to lubricate the bearings for any reason, use Teresso oil 43 or 47 from Esso.

Note: Utmost care must be taken while lubricating, use only one fractional drop of oil for each bearing. Excessive oil might seriously affect the friction drive.

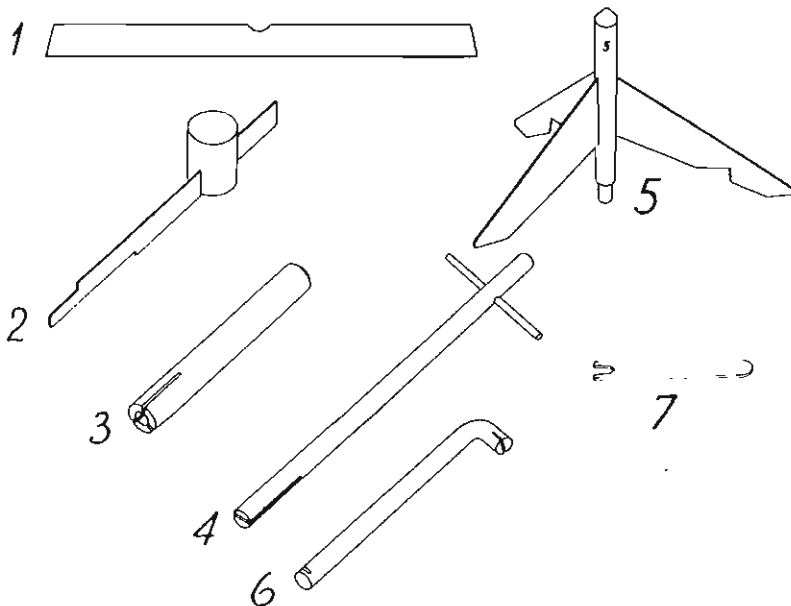

Set of special tools.

1603X

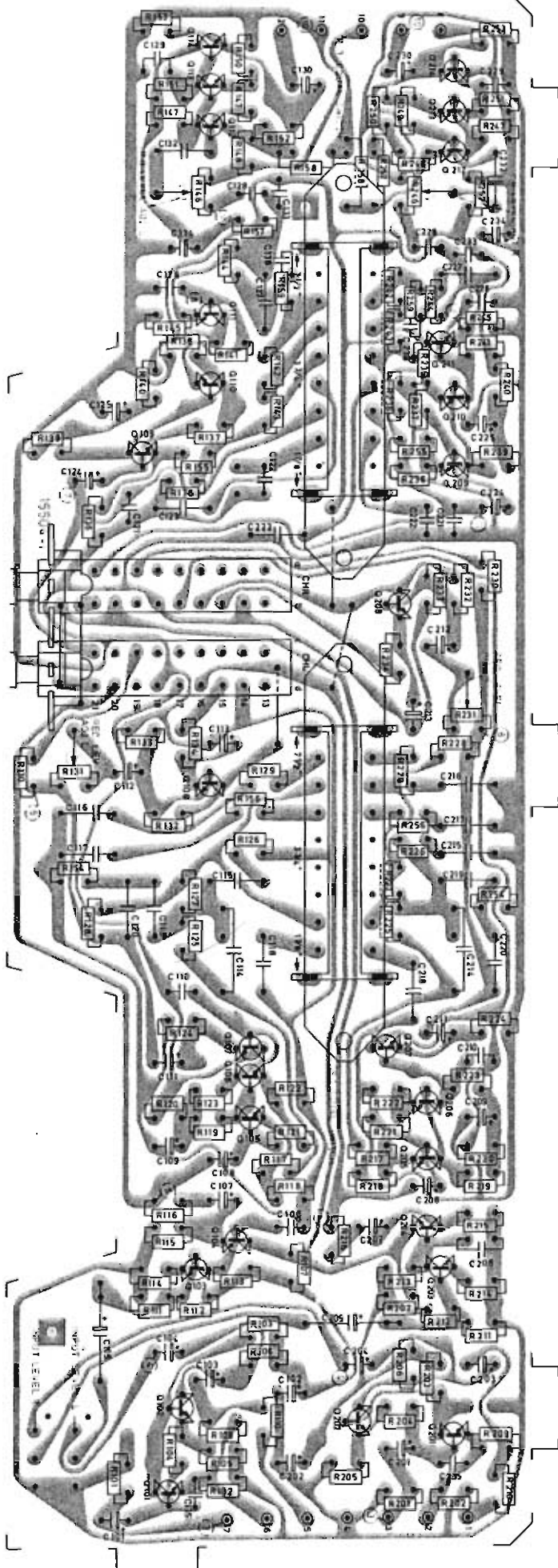

Record and playback amplifier board, printed side.

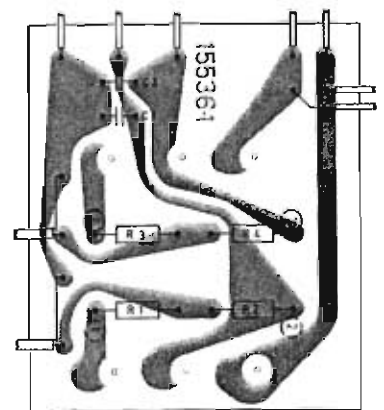

Line input board, printed side.

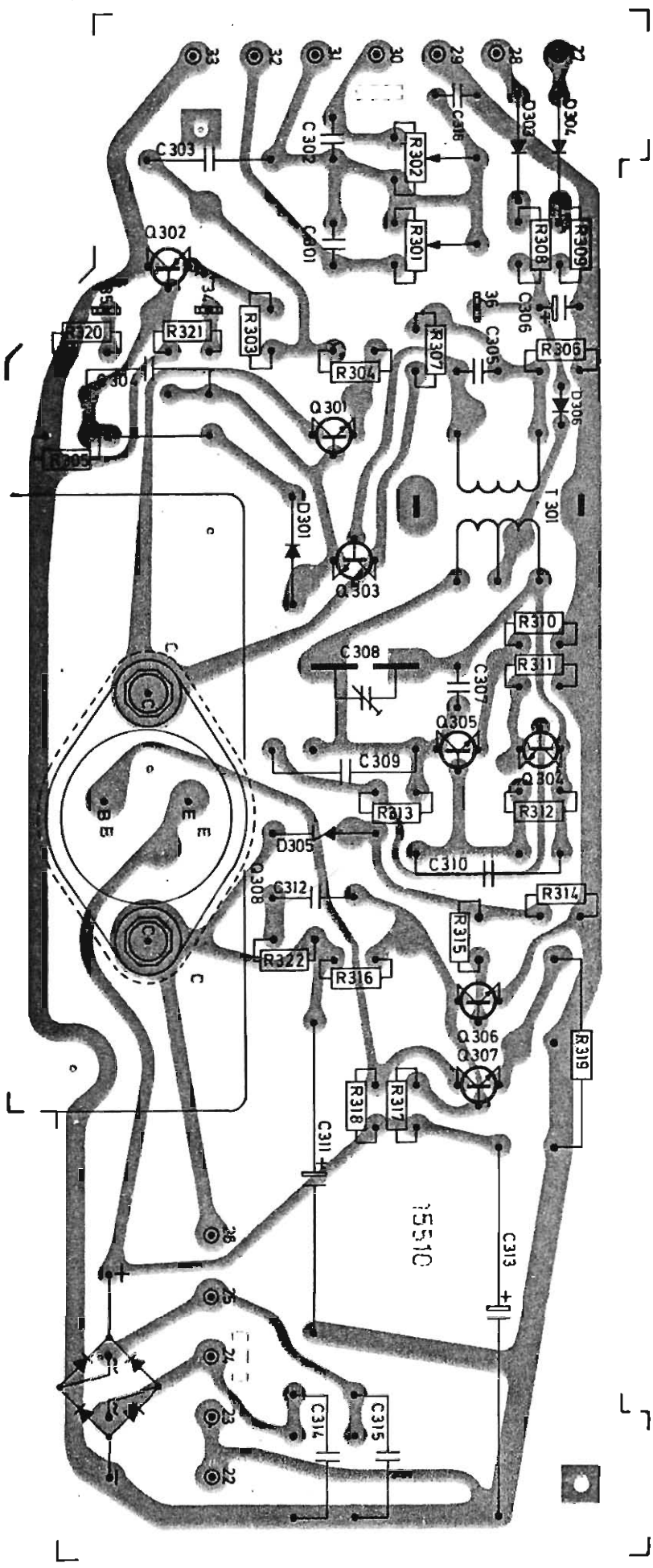

Detector and oscillator board, printed side.



1600

MIC/LINE AMP

BUFFER AMP

EQUALIZED RECORD PREAMP

LEVEL INDICATOR AMP

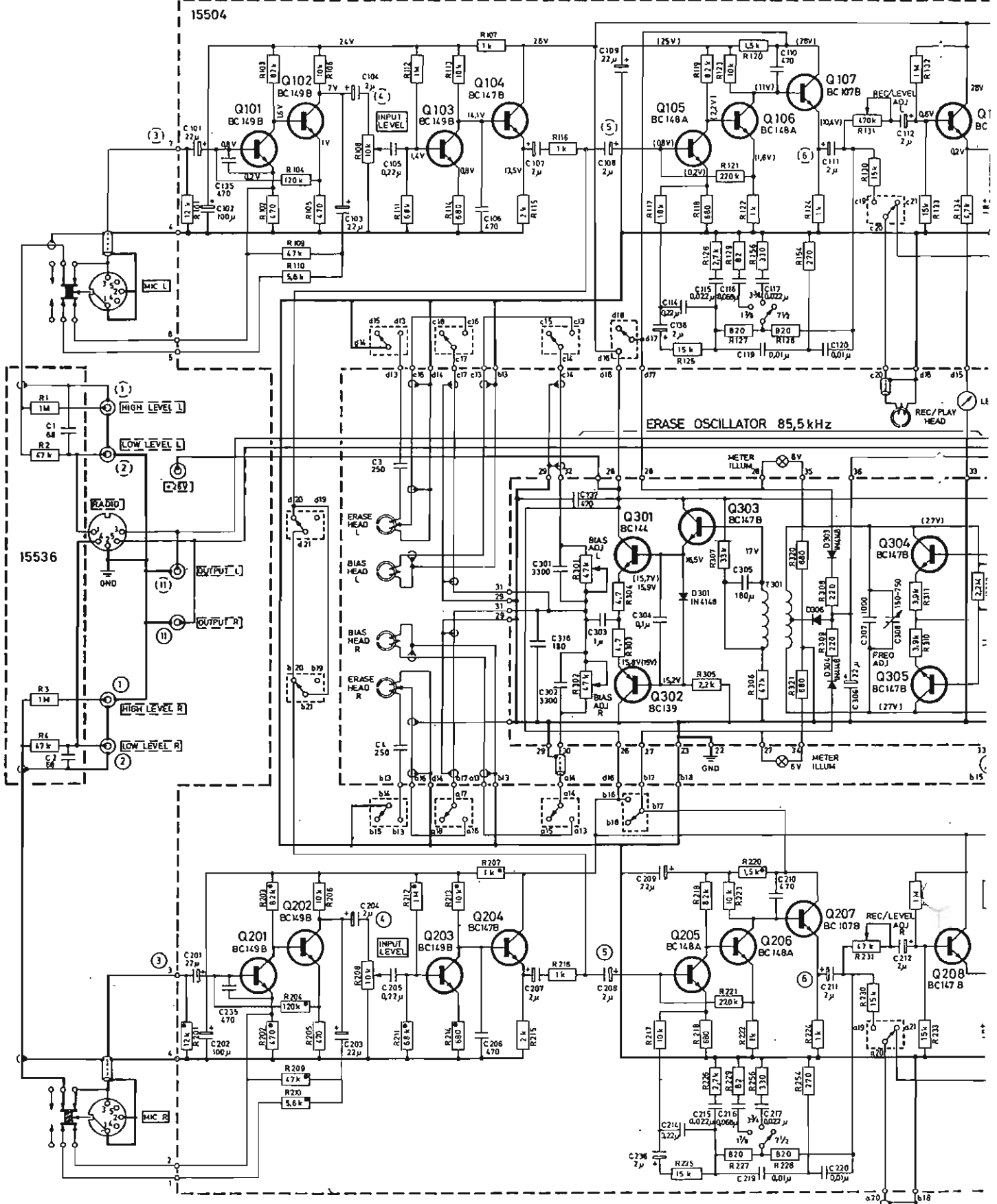

- NOTES:
- [MIC L] = Top plate marking
  - [OUTPUT R] = Rear panel marking
  - = Preset control
  - (L) (R) = Test point
  - = Signal path, playback
  - = Signal path, record

side

INDICATOR AMP      EQUALIZED PLAYBACK AMP      PLAYBACK BOOSTER

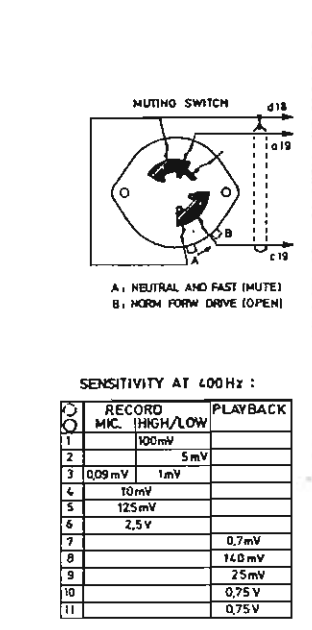
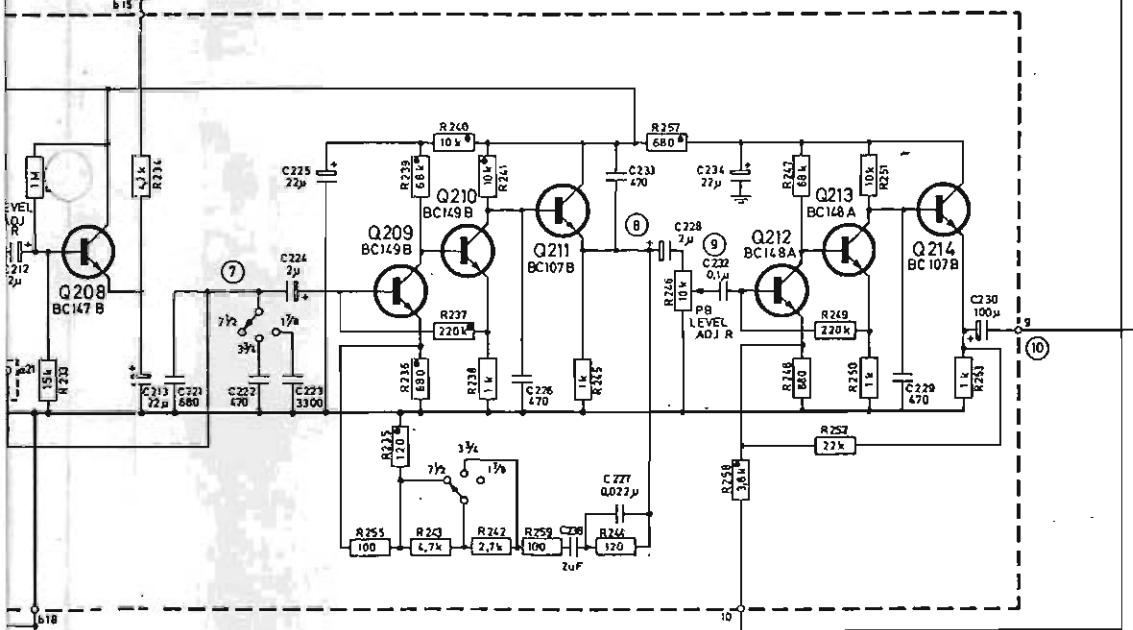
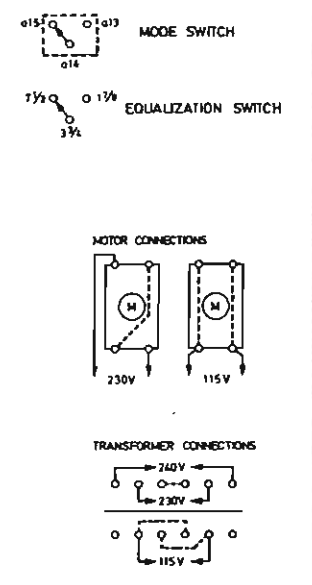
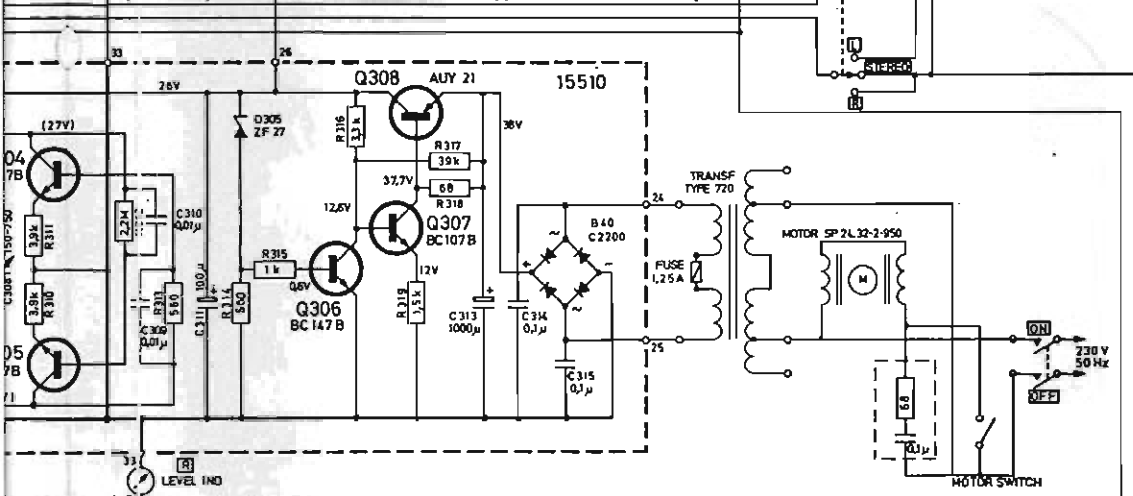
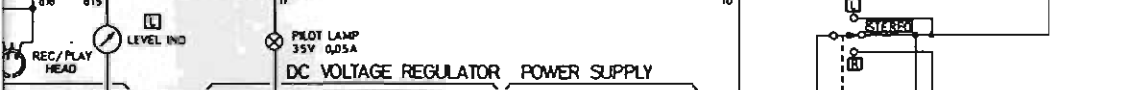
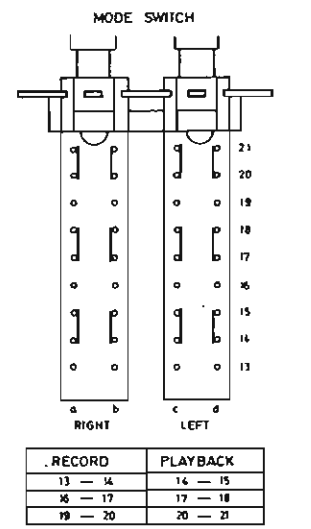
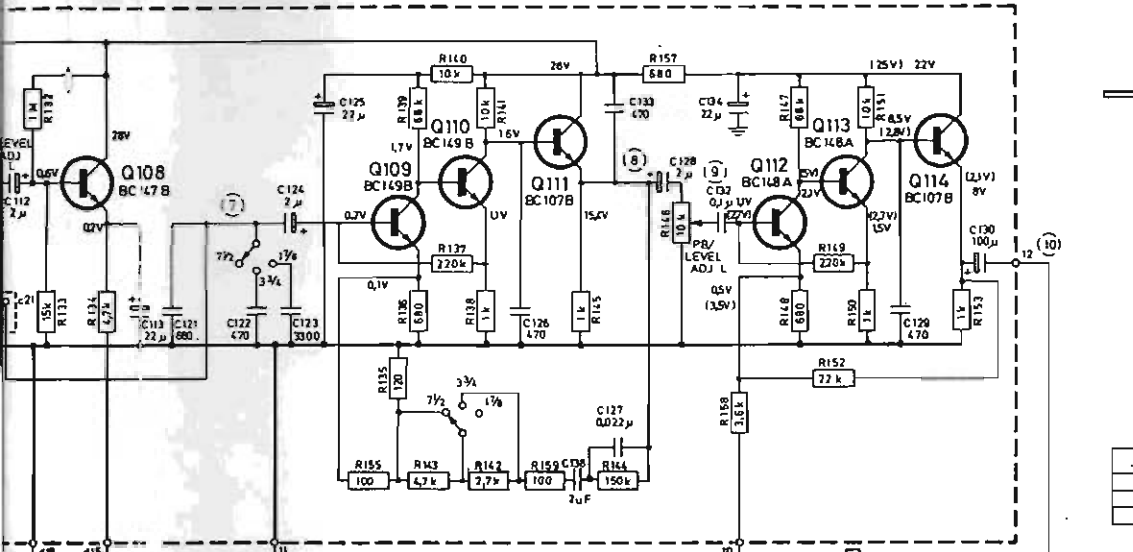

NOTES:  
 O 24 = Connection point  
 L = Upper track = Left channel  
 R = Lower track = Right channel  
 Capacitors indicated in pF unless otherwise specified.  $\mu$  = 1000000 pF  
 Resistors indicated in ohms unless otherwise specified. k = 1000 ohms, M = 1000000 ohms  
 All DC-voltages measured without signal  
 Voltages given in parenthesis refer to record position  
 • = Deposited carbon Resistors

Tondbergs Radiolabrikk A/S  
 WIRING DIAGRAM  
 TAPE RECORDER SERIES 1600 X  
 DRAWING NO 15509-4-  
 19-11-68 JJA  
 14-1-69 JJA  
 7-3-69 JJA  
 19-3-69 JJA  
 8-8-69 JJA