

TANDBERG® TR 3030

Service Manual

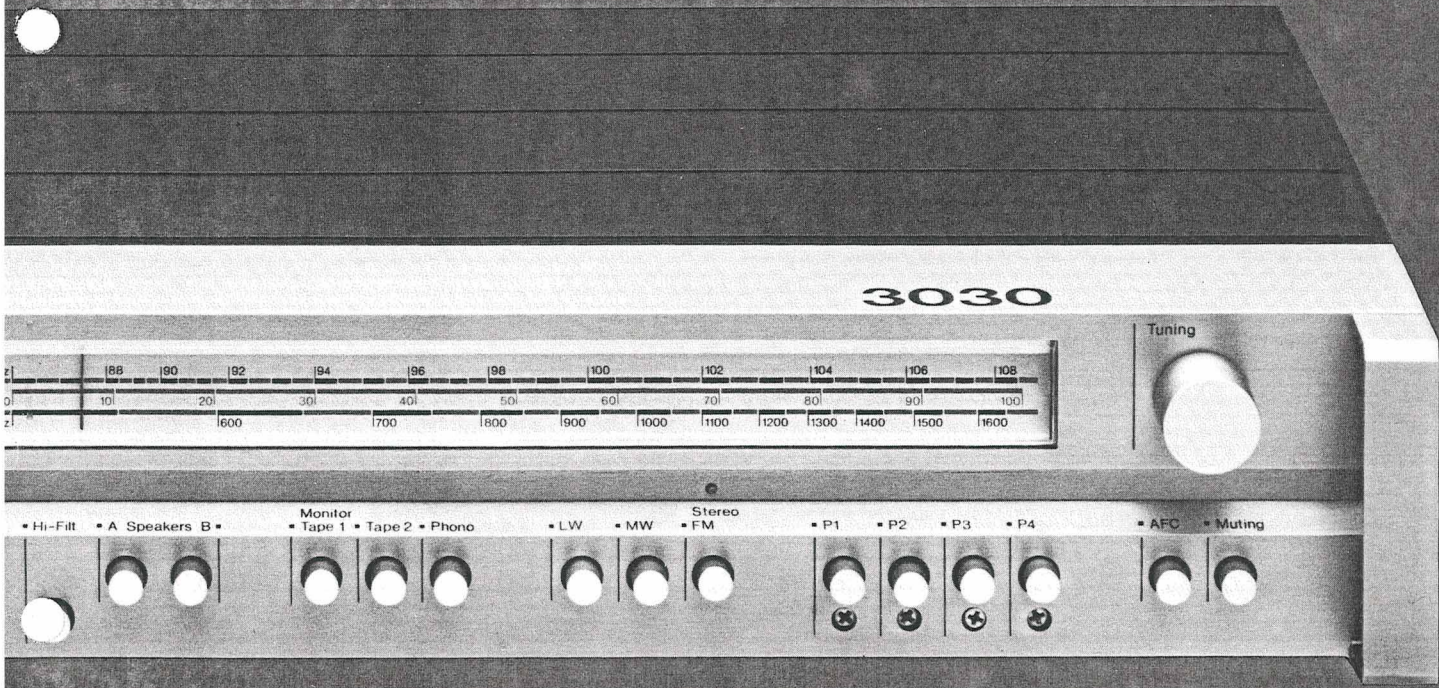

Contents

	Page
Mechanical service	4
Dismantling the chassis	4
Changing lamps, instruments, dial cord, fuses, and diodes	5
Electrical adjustments	6
AM alignment procedure	6
Quiescent current adjustments	6
FM alignment procedure	7
FM selector circuit diagram, European version	8
Connections, FM board	9
AM board with LW	9
FM board	10
Connections, AM board	10
FM selector circuit diagram, US version	11
Audio and power amp. circuit diagram	12
Audio and power board	13
Buffer board	13
Connections to mains transformer	14

Mechanical service

Dismantling the chassis

Top cover

Unscrew the three screws holding the cover and remove it.

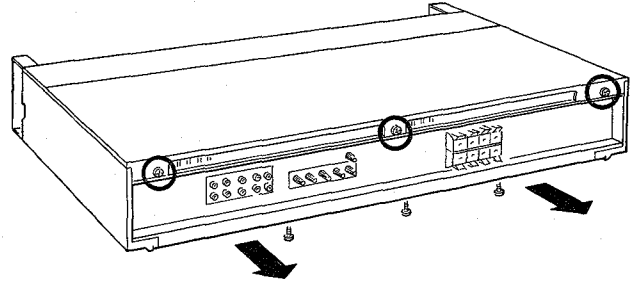

Bottom cover

Unscrew the three screws and pull the cover out, see figure.

Front covers

- Pull off the tuning knob. Unscrew three screws on each side and pull out the handles, see figure.
- Remove the upper front cover.
- Pull off the rotary knobs and remove the lower front cover.

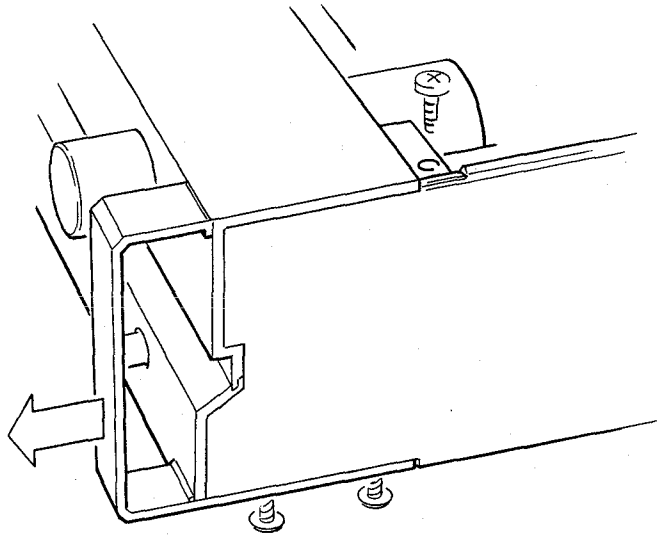

Side panels

Unscrew the two screws on each side and remove the side panels.

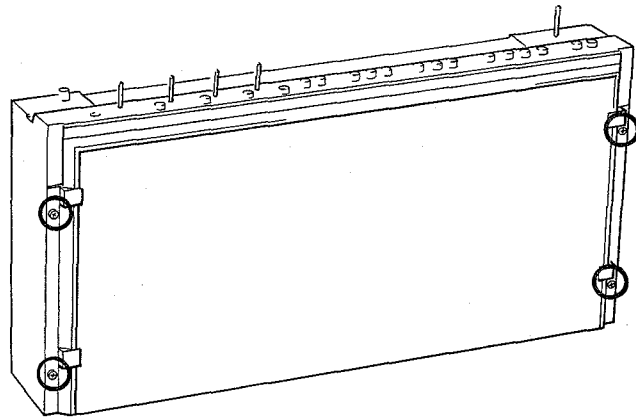

Changing lamps, instruments, dial cord, fuses, and diodes

Scale lamps

Press out the lamp holder and pull out the lamp.

After changing the lamps they must be adjusted for maximum light on the dial. Move the lamp-holder backwards and forwards and seal it with lacquer.

Instruments

Unscrew the two screws holding the plexi glass cover and remove it.

Lift up the dial pointer and remove the dial. The dial is fixed to the chassis with double-sided sticky tape.

Push the instruments out from the inside. They are fixed with double-sided sticky tape.

Diodes

To change a mains or stereo indicator diode, straighten the leads of the diode and pull it out from the front of the receiver.

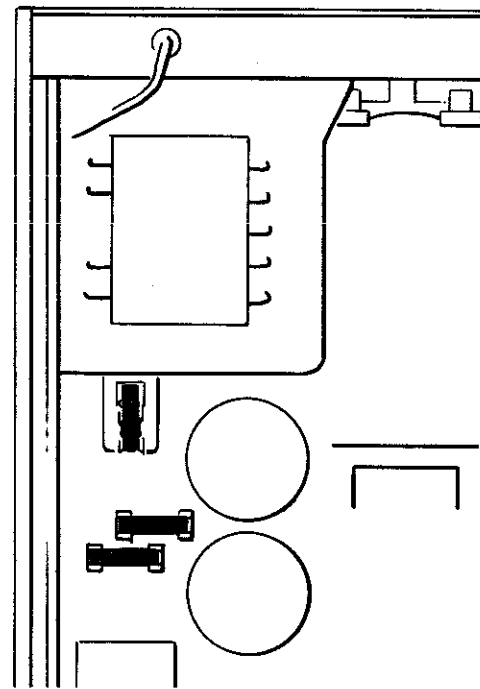
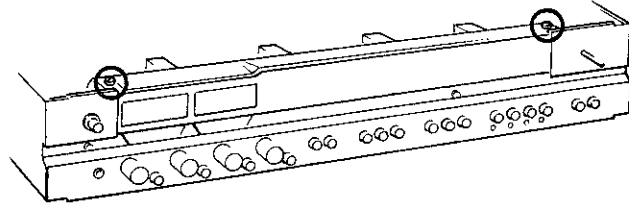

Fuses

To locate the fuses, see figure.

Dial cord

- Turn the dial pointer to the extreme left.
- Unscrew the screw on the AM board.
- Loosen the FM ground screw with a few turns until you can lift out the AM board.
- Press the AM board backwards and lift it out.

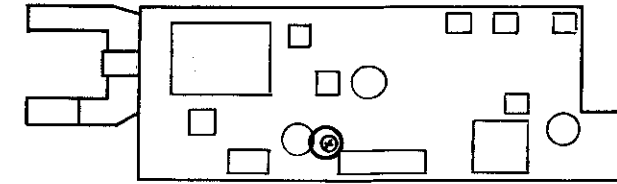
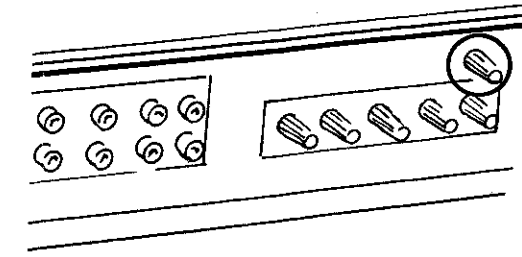

Valid for receivers with serial No's below 10500
Unscrew the two screws on the AM board and pull it out backwards. Then follow the instructions above.

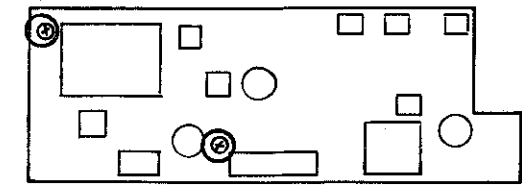

Replace the AM board so that the flywheel shaft goes into the dial cord wheel.

Note! The bracket on the end of the AM board must be placed so that the cord runs freely, see figure.

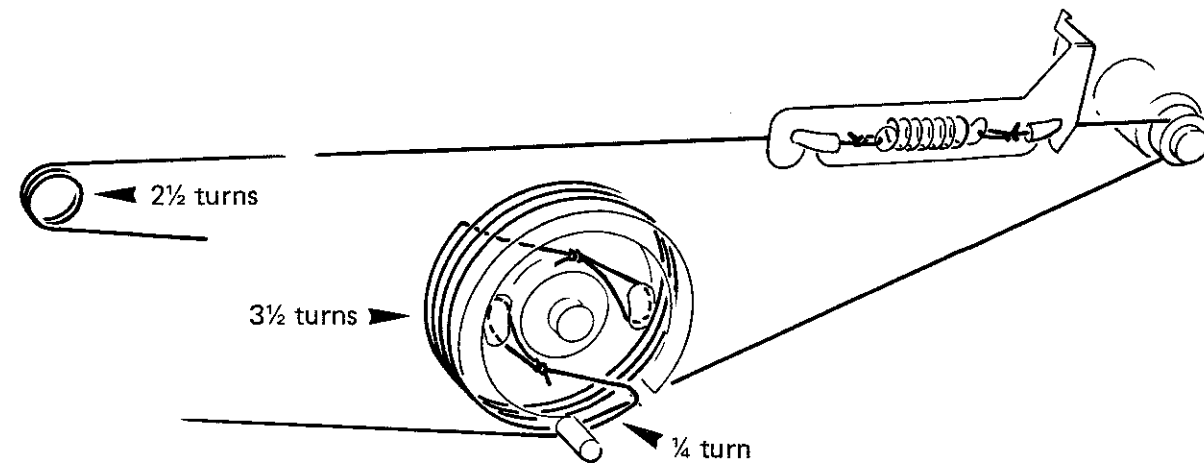
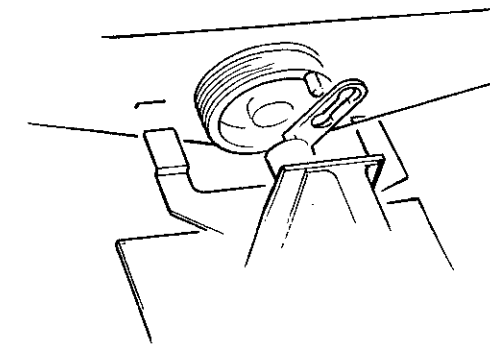

Change the dial cord according to the figure.

Electrical adjustments

AM alignment procedure

Step	Alignment procedure	Receiver		Signal generator		Frequency counter	Oscilloscope	Circuits	Notes
		Frequency	Frequency	Deviation	Connected to	Connected to	Adjust		
1	Osc. MW	518 kHz			M401			L409-410	Adjust frequency counter to 973 kHz.
2	Osc. MW	1630 kHz			M401			C422	Adjust frequency counter to 2085 kHz.
3	Osc. LW	270 kHz			M401			C415	Repeat steps 1 and 2. Adjust frequency counter to 725 kHz.
4	Osc. LW	150 kHz			M401				Check that the frequency counter shows 150 kHz.
5	AGC	1000 kHz						R425	Adjust to 2.2 V on source Q402 with DC meter.
6.	455 kHz trap	1000 kHz	455 kHz	Sweep			R441	L407, L408	Adjust to min. curve height on scope.
7	IF	1400 kHz	1400 kHz	Sweep			R441	L413-414, L415-416, L417, L411-412	Adjust to max. curve height and symmetry.
8	Antenna circuit MW	600 kHz	600 kHz	Sweep			R441	L404-405	Adjust to max. curve height.
9	Antenna circuit MW	1400 kHz	1400 kHz	Sweep			R441	C408	Adjust to max. curve height. Repeat steps 8 and 9.
10	Antenna circuit LW	170 kHz	170 kHz	Sweep			R441	L403	Adjust to max. curve height.
11	Antenna circuit LW	270 kHz	270 kHz	Sweep			R441	C406	Adjust to max. curve height. Repeat steps 10 and 11.
12	Field strength and frequency meter	1400 kHz	1400 kHz	Unmodulated				R449	Adjust to approx. 100 uV on the frequency meter.
13	Distortion	1000 kHz	1000 kHz	30%					< 1% If the frequency meter is adjusted higher than 100 uV the distortion may increase.

Steps 3, 4, 10, and 11 concern European version only.

Quiescent current measurement
Connect the DC meter on the top of:
R837 and R839 (left) R840 and R838 (right)

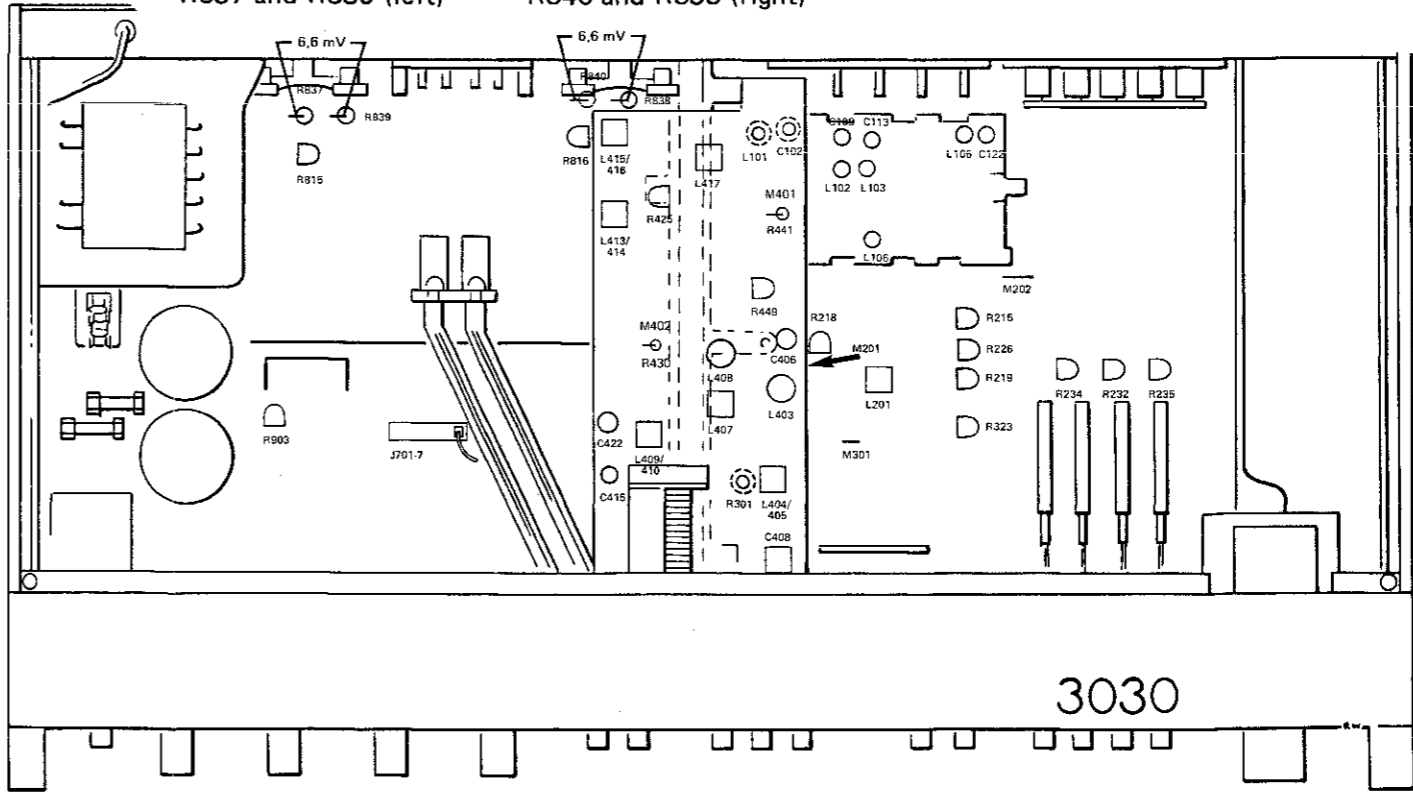

FM alignment procedure

Step	Alignment procedure	Receiver	Signal generator		Connected to	Oscilloscope DC meter	Circuits	Notes
		Frequency	Frequency	Deviation		Connected to	Adjust	
1	25 V for varicap	Pos. FM				Red wire J 701-7	R903	Adjust to 25 ± 0.1 V DC
2	Min. varicap FM	FM dial and field strength meter in left end position				M 202	R234	Adjust to 2.9 V DC
3	Min. varicap preset					M 202	R232	Adjust to 2.9 V DC.
4	Antenna circuit, osc.	90 MHz	90 MHz	Mono ± 200 kHz	Antenna	M201	L105, L101, L102, L103, L106	AFC to off. Check center position of the center meter. Adjust L105 to center. Adjust L101, L102, L103, and L106 to max. curve height.
5	Antenna circuit, osc.	105 MHz	105 MHz	Mono ± 200 kHz	Antenna	M201	C122, C102, C109, C113	AFC to off. Adjust C122 until the curve is in the center of the oscilloscope. Then adjust C102, C109, and C113 for max. curve height. Repeat steps 4 and 5 until oscillator and antenna circuits are optimally adjusted.
6	Preset freq. adjust	Field strength meter in right end position					R235	Adjust frequency meter to 108 MHz.
7	AFC, distortion	98 MHz	98 MHz	Mono ± 75 kHz	Antenna	M201	L201	AFC to off. Adjust tuning knob for symmetrical curve on scope. AFC to on. Adjust L201 for symmetrical curve. When AFC is switched on and off the curve shall not change. Check that the distortion is less than 0.5% on the tape output.
8	Center meter	98 MHz	98 MHz	Mono ± 75 kHz	Antenna	M201	R226	Adjust the meter to center with the signal in center position on the scope.
9	Field strength meter	98 MHz	98 MHz	Mono ± 75 kHz	Antenna > 1 mV		R215	Adjust to 1000 uV.
10	19 kHz oscillator	98 MHz	98 MHz	Mono unmodulated	Antenna > 1 mV	Freq. counter M301	R301	Check that the collector on Q301 is high (approx. 13 V) and adjust to 19 kHz.
11	Stereo level	98 MHz	98 MHz	Stereo 10%, 19 kHz	Antenna 10 uV		R219	Adjust until the stereo lamp is switching on.
12	Muting	98 MHz	98 MHz	± 75 kHz	Antenna 3 uV	Scope to tape output	R218	Muting to off. Adjust until the signal on the oscilloscope disappears.
13	Stereo separation	98 MHz	98 MHz	Stereo ± 75 kHz left or right	Antenna 1 mV	Scope to tape output	R323	Adjust to best compromise < -40 dB.

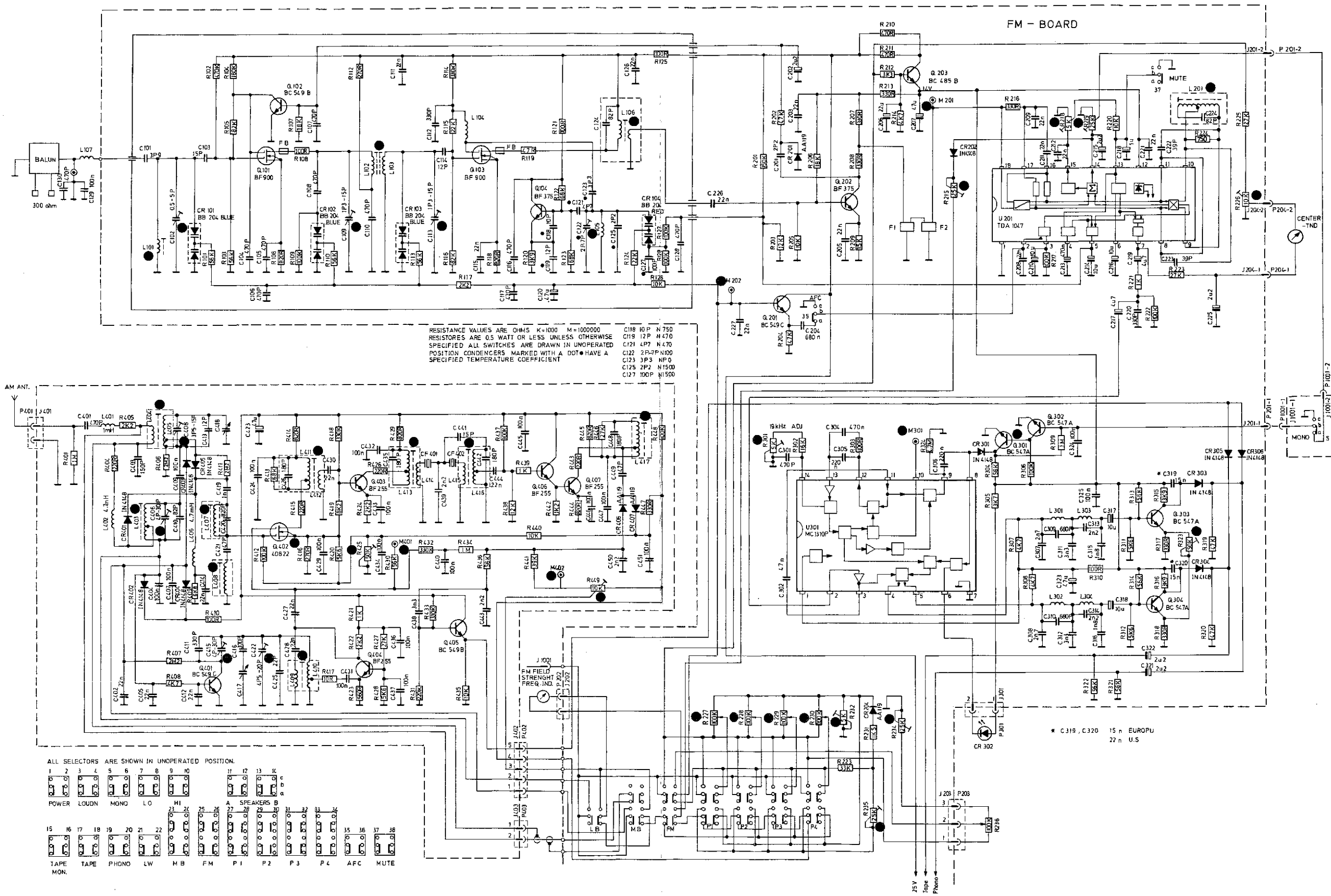

FM SELECTOR CIRCUIT DIAGRAM, EUROPEAN VERSION

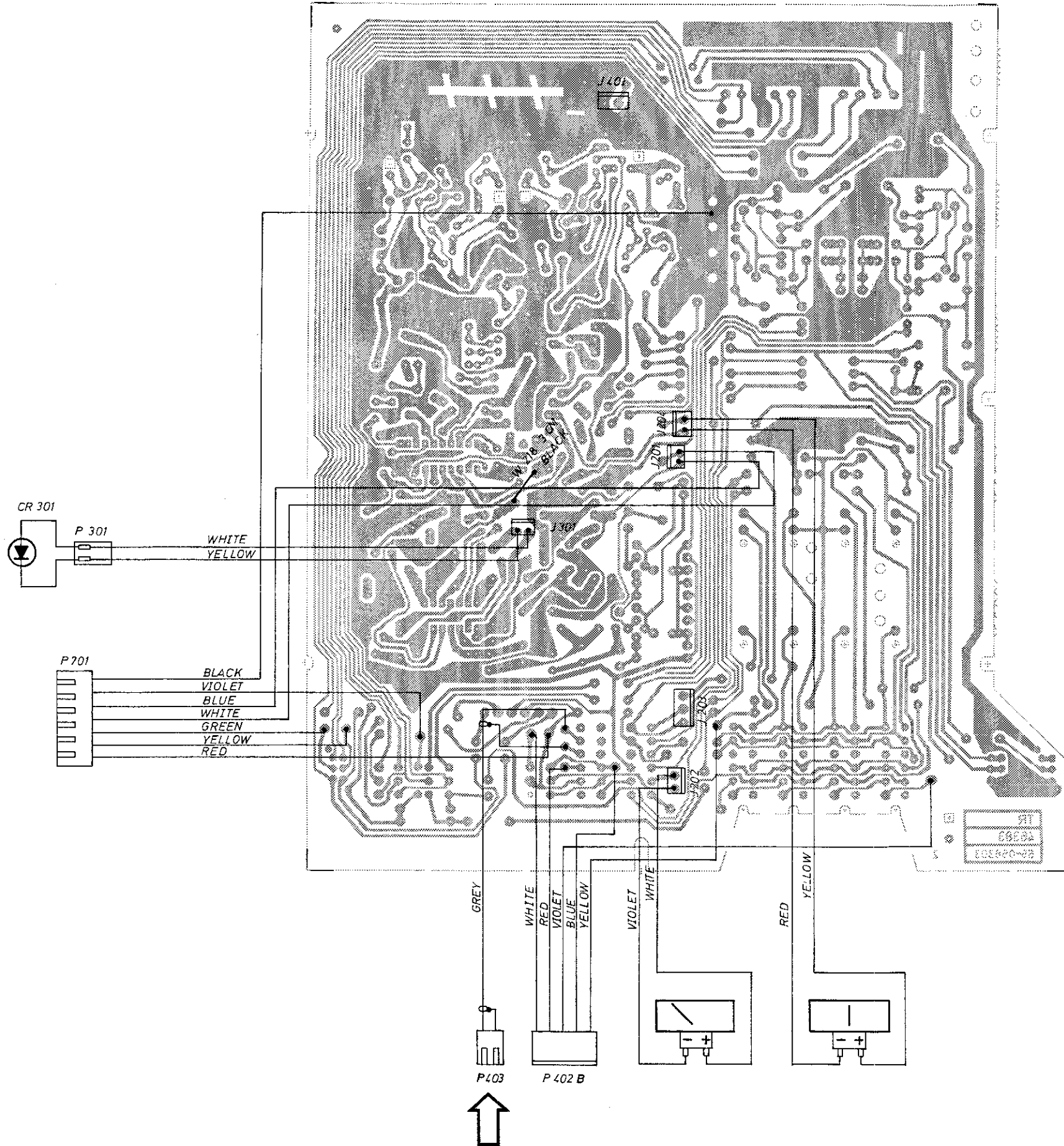

CONNECTIONS, FM BOARD

European version only

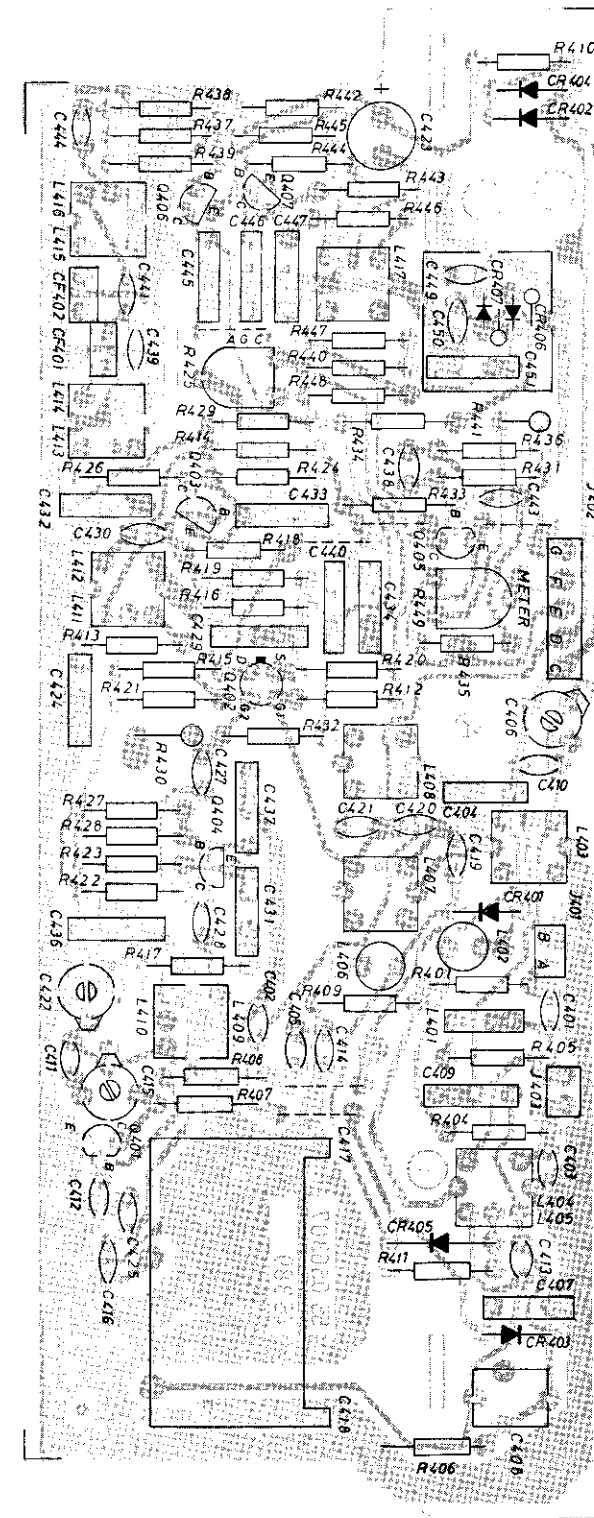

AM BOARD WITH LW, COMPONENT SIDE

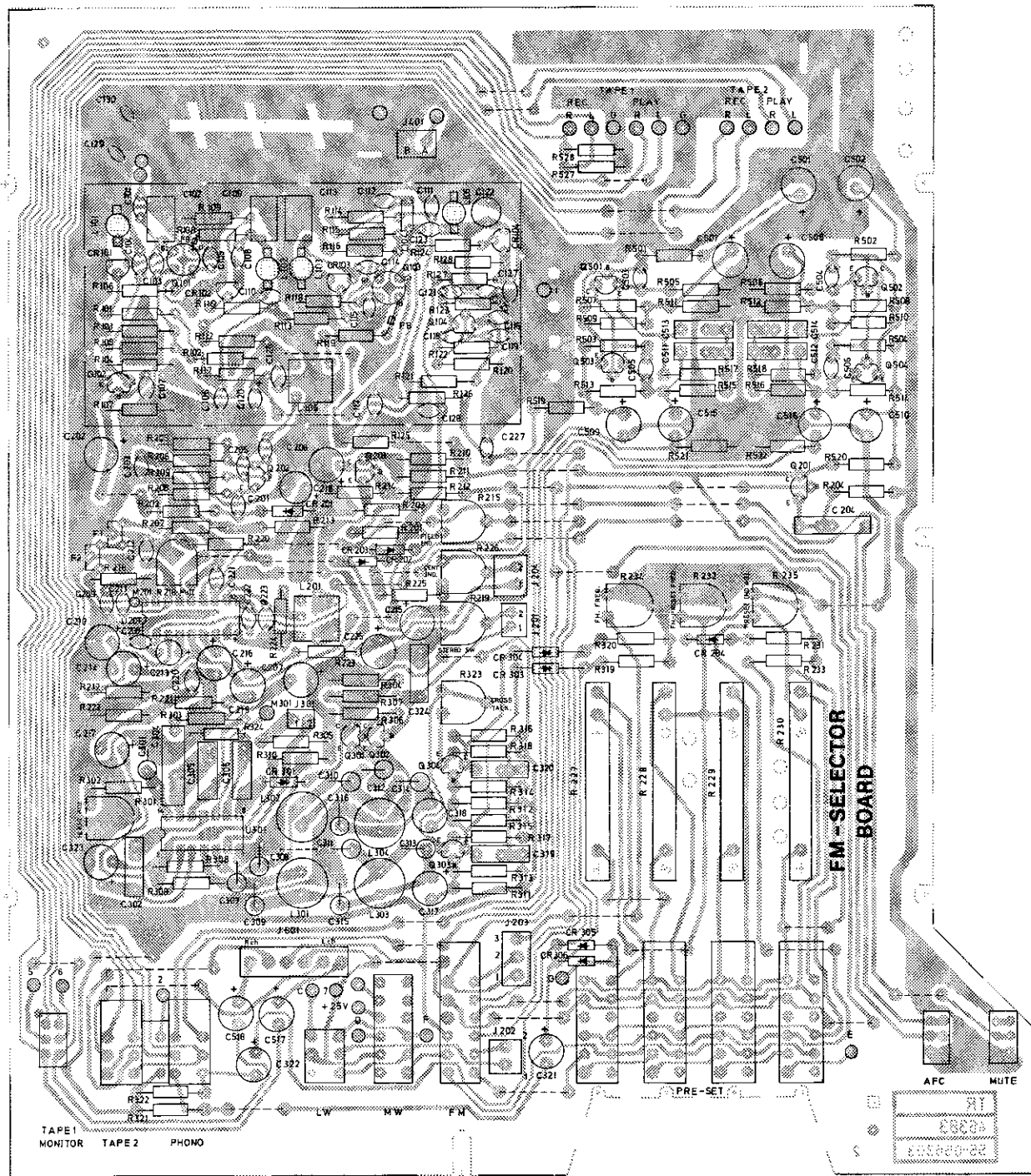

FM BOARD

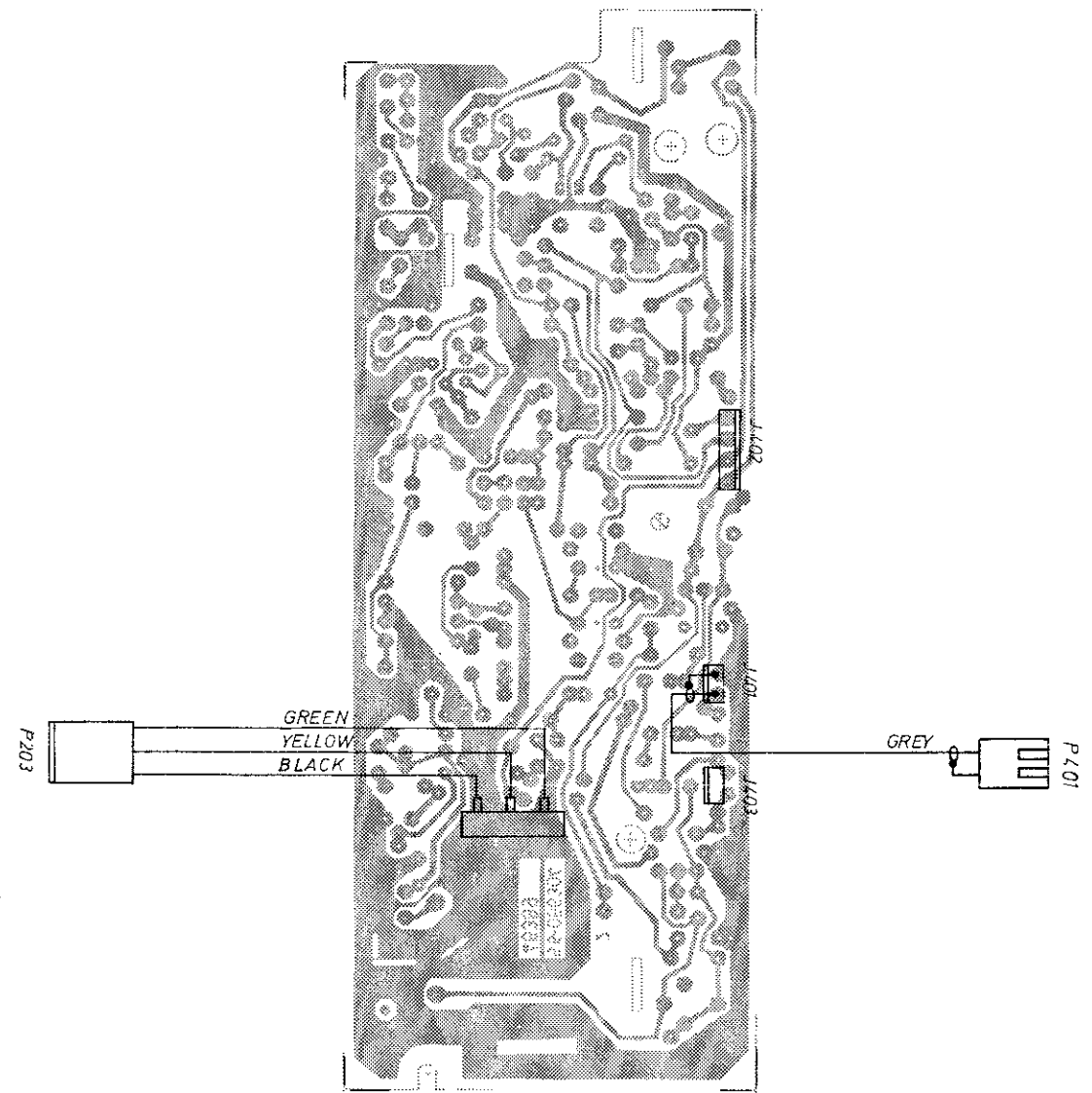

CONNECTIONS, AM BOARD

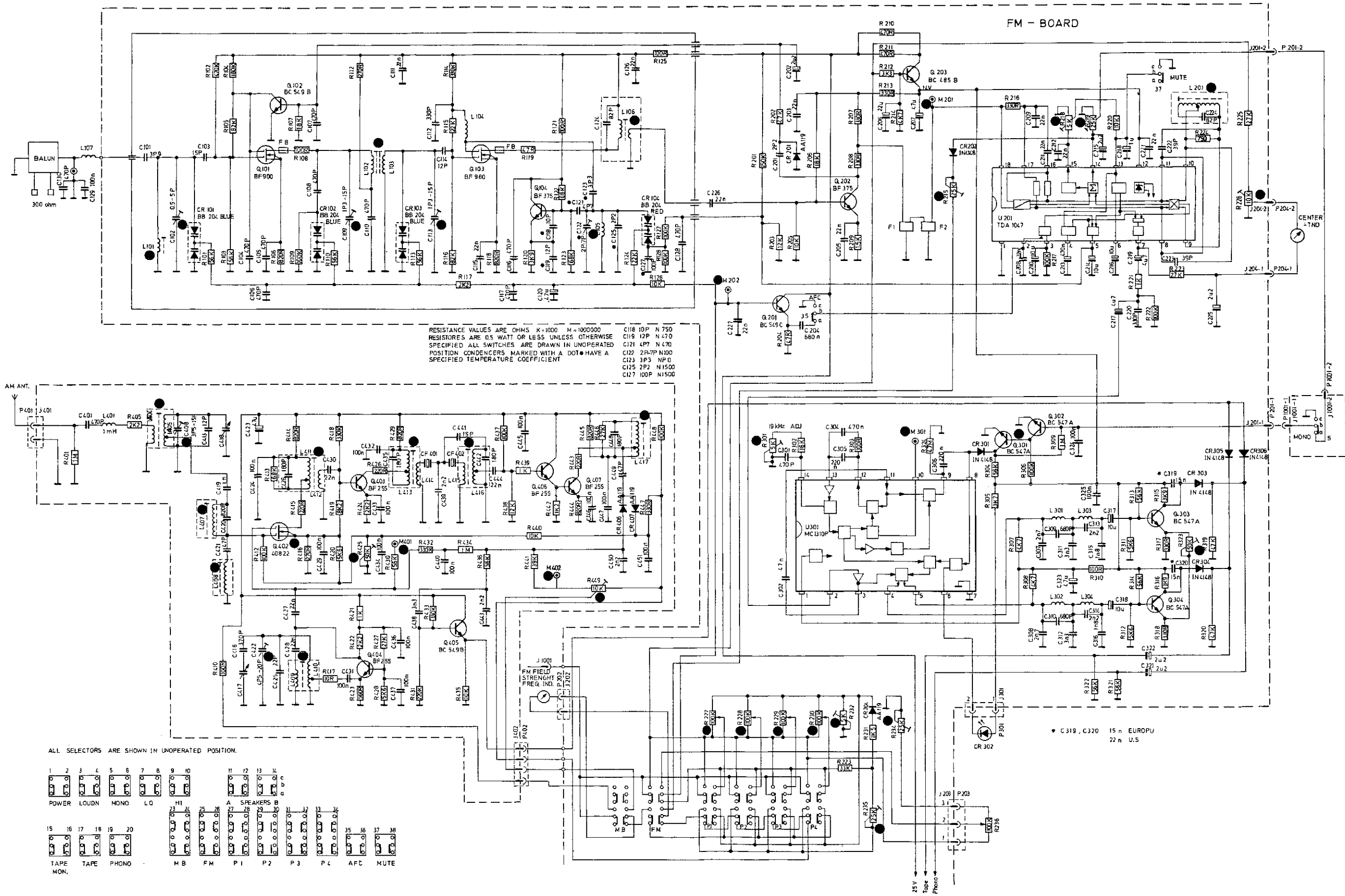

FM SELECTOR CIRCUIT DIAGRAM, US VERSION

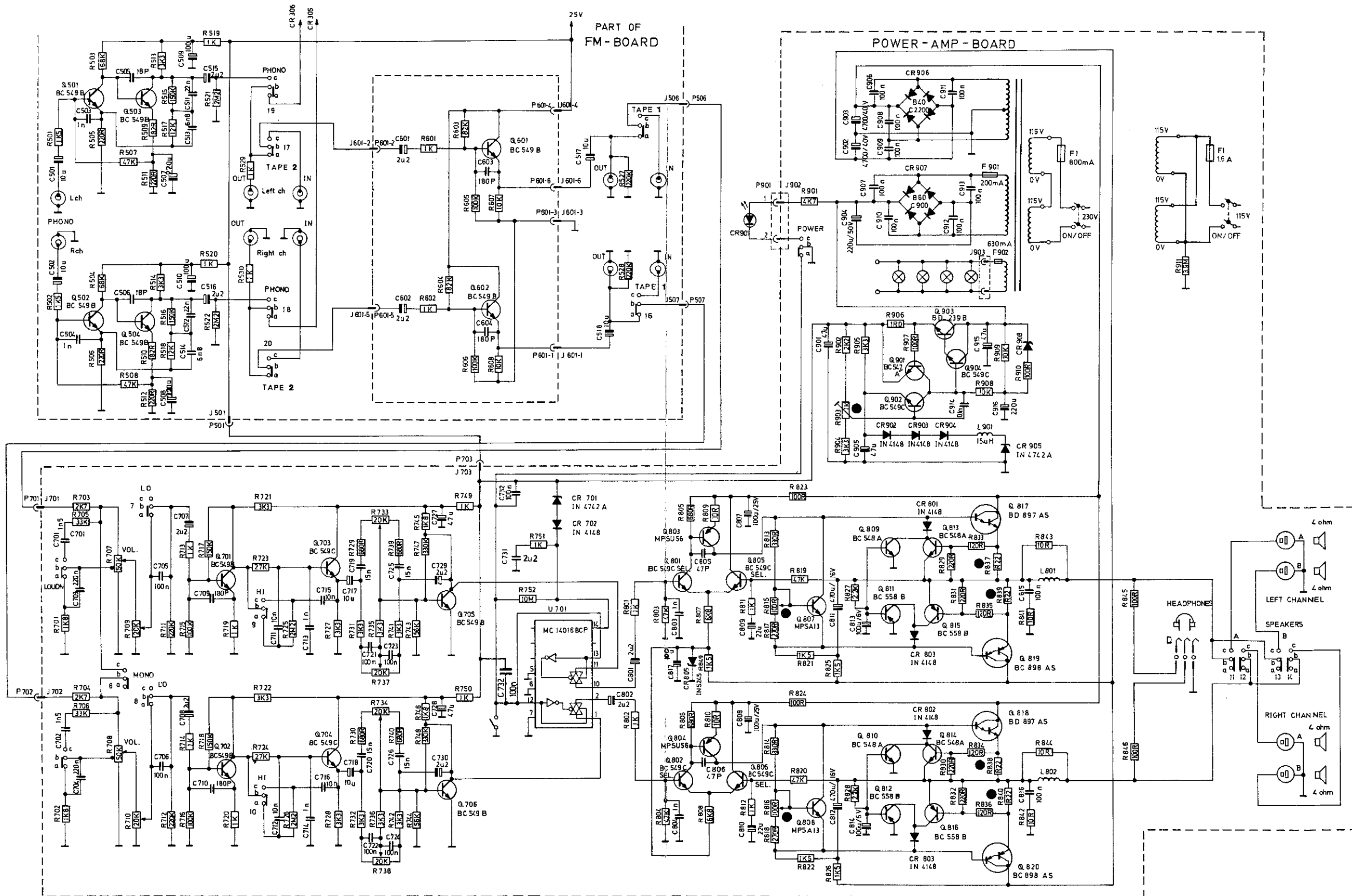

AUDIO AND POWER AMP. CIRCUIT DIAGRAM

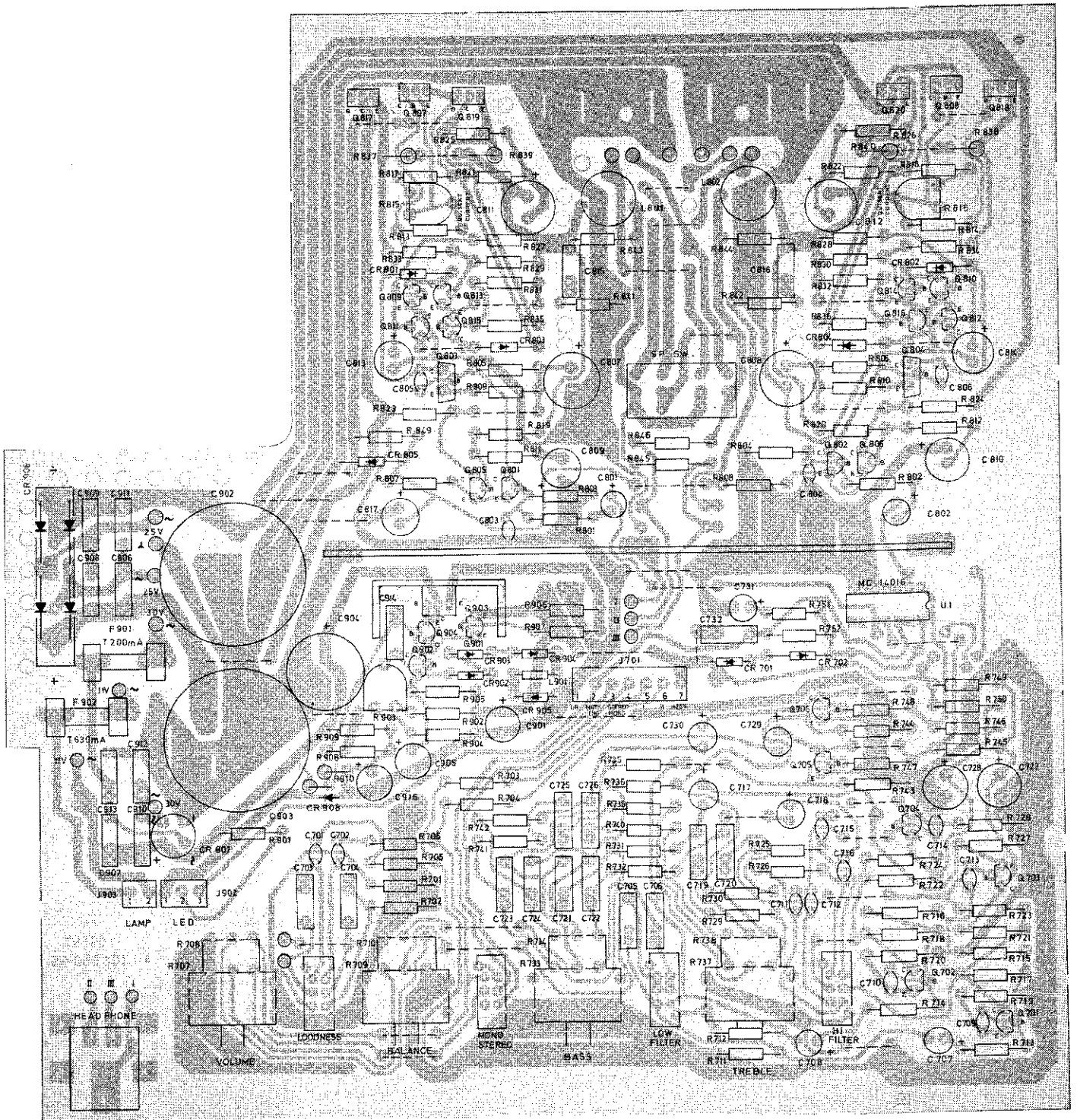

AUDIO AND POWER BOARD

Quiescent current

Measure across R837 and R840. Adjust R815 and R816 to 6.6 mV after approx. 10 minutes warm-up.

For complete adjustment, see page 6.

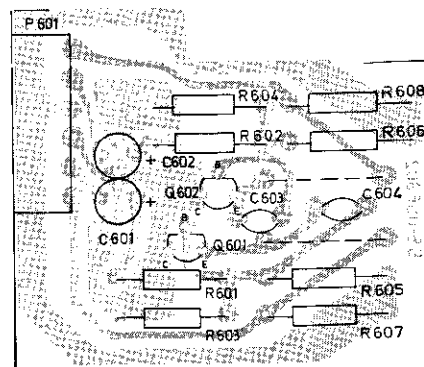

BUFFER BOARD

Connections to mains transformer

To change the wiring of the power supply transformer to suit another power supply voltage, see figure.

