

SERVICE
MANUAL

PM-64/PM-54

4822 725 50317

marantz®

model PM-64/PM-54

Stereo Pre Main Amplifier

TABLE OF CONTENTS

SECTION	PAGE
INTRODUCTION	1
1. SHOCK, FIRE HAZARD SERVICE TEST:	1
2. P.W. BOARDS	1
3. TEST EQUIPMENT REQUIRED FOR SERVICING	2
4. ALIGNMENT PROCEDURES	2
5. VOLTAGE CONVERSION	2
6. CIRCUIT DESCRIPTION	3
7. BLOCK DIAGRAM	6
8. SCHEMATIC DIAGRAM AND COMPONENT LOCATIONS	8
8.1 Phono Amp/Input Jack (P401) Schematic Diagram and Component Locations	8
8.2 Main Amp/Power Supply (P701) Schematic Diagram and Component Locations	10
8.3 Tone Amp (PE01) Schematic Diagram and Component Locations	16
8.4 Volume, Balance (PT01) Schematic Diagram and Component Locations	17
8.5 Power Switch (P851) Schematic Diagram and Component Locations	17
8.6 Compo-Multi (PU51) Schematic Diagram and Component Locations	18
8.7 Tape 2 In/Out Jack (PV01) Schematic Diagram and Component Locations	18
8.8 Phones (PW51) Schematic Diagram and Component Locations	18
8.9 Indicator (PY01) Schematic Diagram and Component Locations	18
9. EXPLODED VIEW AND PARTS LIST	19
10. ELECTRICAL PARTS LIST	24
11. TECHNICAL SPECIFICATIONS	30
12. SCHEMATIC DIAGRAM	32

For Service Manuals Contact
MAURITRON TECHNICAL SERVICES
 8 Cherry Tree Rd, Chinnor
 Oxon OX9 4QY
 Tel:- 01844-351694 Fax:- 01844-352554
 Email:- enquiries@mauritron.co.uk

For Service Manuals Contact
MAURITRON TECHNICAL SERVICES
 8 Cherry Tree Rd, Chinnor
 Oxon OX9 4QY
 Tel:- 01844-351694 Fax:- 01844-352554
 Email:- enquiries@mauritron.co.uk

MODEL PM-64/PM-54 STEREO PRE MAIN AMPLIFIER

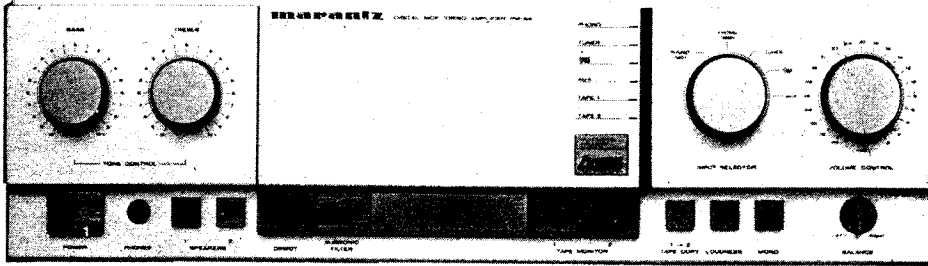

For Service Manuals Contact
MAURITRON TECHNICAL SERVICES
 8 Cherry Tree Rd, Chinnor
 Oxon OX9 4QY
 Tel:- 01844-351694 Fax:- 01844-352554
 Email:- enquiries@mauritron.co.uk

PM-64

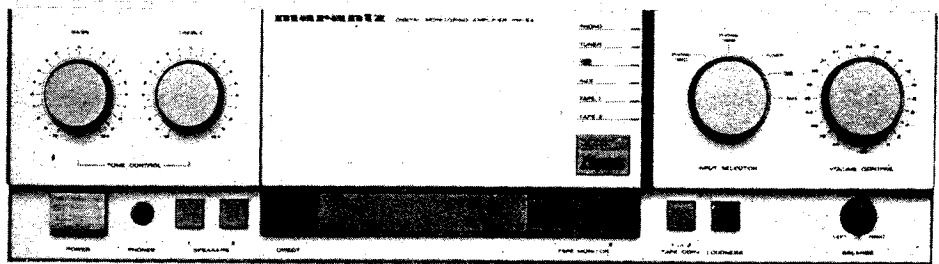

PM-54

INTRODUCTION

This service manual was prepared for use by Authorized Warranty Stations and contains service information for the Marantz Model PM-64/PM-54 Stereo Pre Main Amplifier.

Servicing information and voltage data included in this manual are intended for use by knowledgeable and experienced personnel only. All instructions should be read carefully. No attempt should be made to proceed without a good understanding of circuitry operation.

The parts list furnishes complete ordering information. Most replacement parts should be ordered from the Marantz Company. However, a simple description is included for parts which can be obtained locally.

1. SHOCK, FIRE HAZARD SERVICE TEST:

CAUTION: After servicing this appliance and prior to returning to customer, measure the resistance between either primary AC cord connector pins (with unit NOT connected to AC mains and its Power switch ON), and the face or front Panel of product and controls and chassis bottom.

Any resistance measurement less than 1 Megohms should cause unit to be repaired or corrected before AC power is applied, and verified before return to user/customer.

Ref. UL Standard NO. 1270. Para 66. 3. D (Mandatory Test after servicing Electrical Appliances, effective 7-1-83).

2. P.W. BOARDS

As can be seen from the circuit diagram the chassis of Model PM-64/PM-54 consists of the following units. Each unit mounted on a printed circuit board is described within the square enclosed by a bold dotted line on the circuit diagram.

1. Phono Amp/Input Jack mounted on P.W. Board P401
2. Main Amp/Power Supply mounted on P.W. Board P701
3. Power Switch mounted on P.W. Board P851
4. Tone Amp mounted on P.W. Board PE01
5. Volume, Balance mounted on P.W. Board PT01
6. Compo-Multi mounted on P.W. Board PU51
7. Tape 2 In/Out Jack mounted on P.W. Board PV01
8. Phones mounted on P.W. Board PW51
9. Indicator mounted on P.W. Board PY01

3. TEST EQUIPMENT REQUIRED FOR SERVICING

This table lists the test equipment required for servicing the Model PM-64/PM-54 Stereo Pre Main Amplifier.

Item	Use
Distortion Analyzer	Distortion measurements
Audio Oscillator	Sinewave and squarewave signal source
AC VTVM	Voltage measurements (AC)
Oscilloscope	Waveform analysis and trouble shooting and ASO alignment
Circuit Tester	Trouble shooting
DC VTVM	Voltage measurements (DC)
AC Wattmeter	Monitors primary power to amplifier
Line Voltmeter	Monitors potential of primary power to amplifier
Variable Autotransformer (0 ~ 140V AC, 10A)	Adjust level of primary power to amplifier
Shorting Plug	Shorts amplifier input to eliminate noise pickup

4. ALIGNMENT PROCEDURES

• Idling Adjustment

1. Set the load at the speaker terminals to the open condition.
2. Connect a DC voltmeter between TP-1 and TP-2.
3. Adjust R731 (semi-fixed resistor) so that the DC voltmeter displays 8.8mV.
4. Adjust R732 in the same manner over TP-3 and TP-4 for the right channel.

5. VOLTAGE CONVERSION

• European Model Only

To convert the unit to a different power source voltage, change the position as illustrated in the drawing below.

CAUTION
DISCONNECT POWER SUPPLY CORD FROM AC OUTLET BEFORE CONVERTING VOLTAGE.

Voltage Conversion Chart

For Service Manuals Contact
MAURITRON TECHNICAL SERVICES
8 Cherry Tree Rd, Chinnor
Oxon OX9 4QY
Tel:- 01844-351694 Fax:- 01844-352554
Email:- enquiries@mauritron.co.uk

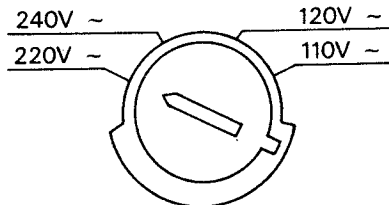
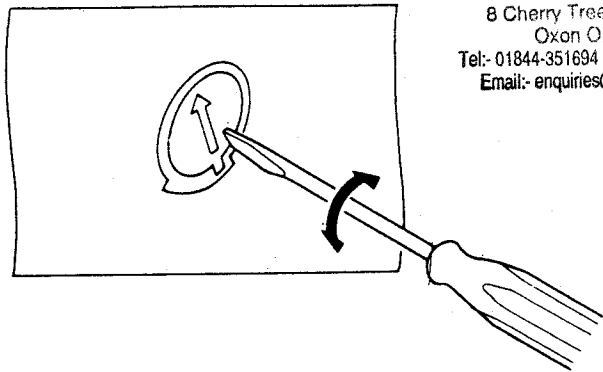

VOLTAGE SELECTOR

Note on safety: Symbol Δ Fire or electrical shock hazard. Only original parts should be used to replace any part marked with symbol Δ . Any other component substitution (other than original type), may increase risk of fire or electrical shock hazard.

6. CIRCUIT DESCRIPTION

• Audio Power Drive Amplifier

1. Maximum ratings $T_a = 25^\circ\text{C}$

Item	Symbol	Conditions	Maximum ratings	Units
Operating supply current	V_{cc}		± 75	V
IC board operating temperature	T_c		115	$^\circ\text{C}$
Storage temperature	T_{stg}		$-30 \sim -115$	$^\circ\text{C}$
Package power dissipation	P_d			W

2. Operating characteristics

$T_a = 25^\circ\text{C}$, $R_L = 33\text{k}\Omega$, (1) $V_H = 40\text{ dB}$ (2) $V_G = 26.5\text{ dB}$, measurements at the specified circuits

Item	Symbol	Test conditions				Test circuit	Standard values			Units
		V_{cc} (V)	f (Hz)	V_o (V)			Min.	Typ.	Max.	
Quiescent current	I_{cc}	± 60				(1)		26	40	nA
Medium voltage (1)	V_N (1)	± 60				(1)	- 50		+ 50	nV
Output noise voltage	V_{No}^{*1}	± 60			$R_g = 0\Omega$	(1)			1.0	nV
Input impedance	r_i	± 60	- 1k	2/83		(1)		0.005	0.01	
Total harmonic distortion	THD (1)	± 50	20K	28.3		(1)		0.005	0.1	%
	THD (2)									
	THD (3)									
Medium voltage (2)	V_N (2)	± 60				(2)	- 70		+ 70	nV

For Service Manuals Contact
MAURITRON TECHNICAL SERVICES
 8 Cherry Tree Rd, Chinnor
 Oxon OX9 4QY
 Tel:- 01844-351694 Fax:- 01844-352554
 Email:- enquiries@mauritron.co.uk

3. Internal equivalent circuit

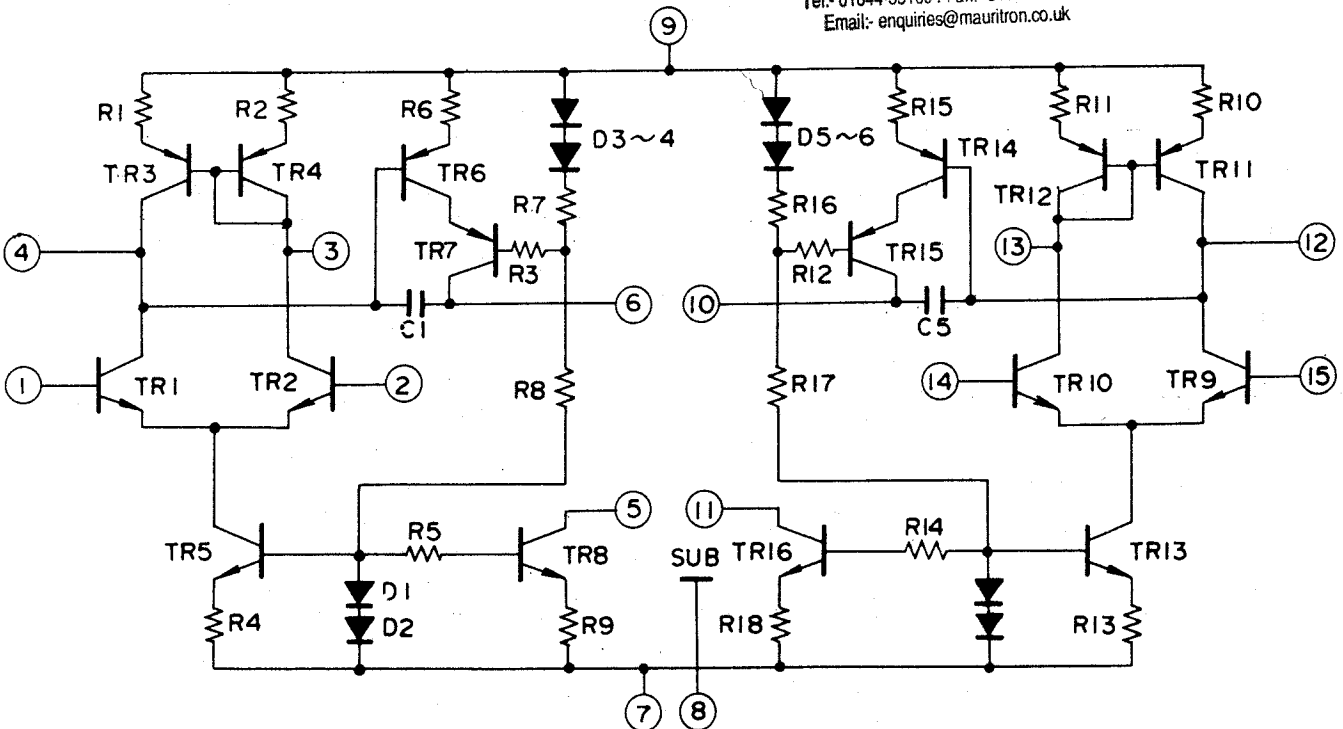

• Silicon PNP Expitaxial Planer Type, Low Frequency Power Amplification Transistor 2SD1266 (Q801)

1. Absolute maximum ratings

T_a = 25°C

Item	Symbol	Conditions	Maximum ratings	Units
Collector-base voltage	V _{CB0}		60	V
Collector-emitter voltage	V _{CEO}		60	V
Emitter-base voltage	V _{EBO}		6	V
Front collector current	I _{cp}		5	A
Collector current	I _c		3	A
Collector loss	P _c	T _c = 25°C	35	W
		T _a = 25°C	2	
Junction temperature	T _j		150	°C
Storage temperature	T _{stg}		- 55 ~ + 150	°C

2. Electrical characteristics

T_a = 25°C

Item	Symbol	Test Conditions				Standard values			Units
		V _{CE} (V)	V _{BE} (V)	I _c (A)	I _B (A)	Min.	Typ.	Max.	
Collector breaking current	I _{CES}	60	0					2.00	μA
	I _{CEO}	60			0			300	μA
Emitter breaking current	I _{EBO}		5	0				1	mA
Collector-emitter voltage	V _{CEO}			30m	0	60			V
DC amplification rate	h _{FE1}	4		1		40		250	
	h _{FE2}	4		3		10			
Base-emitter voltage	V _{BE}	4		3				1.8	V
Collector-emitter saturation voltage	V _{CE(sat)}			3	0.375			1.2	V
Turn-on time	T _{on}			1	0.1		0.5		μs
Storage time	T _{stg}			1	0.1		2.5		μs
Fall time	t _f			1	0.1		0.4		μs

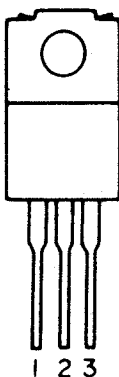

For Service Manuals Contact
 MAURITRON TECHNICAL SERVICES
 8 Cherry Tree Rd, Chinnor
 Oxon OX9 4QY
 Tel:- 01844-351694 Fax:- 01844-352554
 Email:- enquiries@mauritron.co.uk

1. Base
2. Collector
3. Emitter

• Silicon PNP Expitaxial Planer Type, Low Frequency Power Amplification Transistor 2SB941 (Q802)

1. Absolute maximum ratings

T_a = 25°C

Item	Symbol	Conditions	Maximum ratings	Units
Collector-base voltage	-V _{CBO}		60	V
Collector-emitter voltage	-V _{CEO}		60	V
Emitter-base voltage	-V _{EBO}		5	V
Front collector current	-I _{CP}		5	A
Collector current	-I _C		3	A
Collector loss	P _c	T _c = 25°C	35	W
		T _a = 25°C	2	
Junction temperature	T _j		150	°C
Storage temperature	T _{stg}		-55 ~ +150	°C

2. Electrical characteristics

T_a = 25°C

Item	Symbol	Test Conditions				Standard value			Units
		V _{CE} (V)	V _{BE} (V)	I _C (A)	I _B (A)	Min.	Typ.	Max.	
Collector breaking current	-I _{CES}	-60	0					2 00	μA
Emitter breaking current	-I _{CEO}	-60			0			300	μA
	-I _{EBO}		-5	0				1	mA
Collector-emitter voltage	-V _{CEO}			-30m	0	60			V
DC amplification rate	h _{FE1}	-4		-1		40		250	
	h _{FE2}	-4		-3		10			
Base-emitter voltage	-V _{BE}	-4		-3				1.8	V
Collectoremitter saturation voltage	-V _{CE(sat)}			-3	-0.375			1.2	V
Turnon time	T _{on}			-1	-0.1		0.5		μs
Storage time	T _{stg}			-1	-0.1		1.2		μs
Fall time	t _f			-1	-0.1		0.3		μs

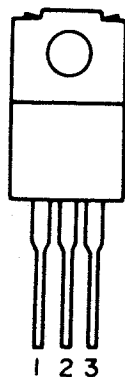

1. Base
2. Collector
3. Emitter

For Service Manuals Contact
 MAURITRON TECHNICAL SERVICES
 8 Cherry Tree Rd, Chinnor
 Oxon OX9 4QY
 Tel:- 01844-351694 Fax:- 01844-352554
 Email:- enquiries@mauritron.co.uk

7. BLOCK DIAGRAM PM-64

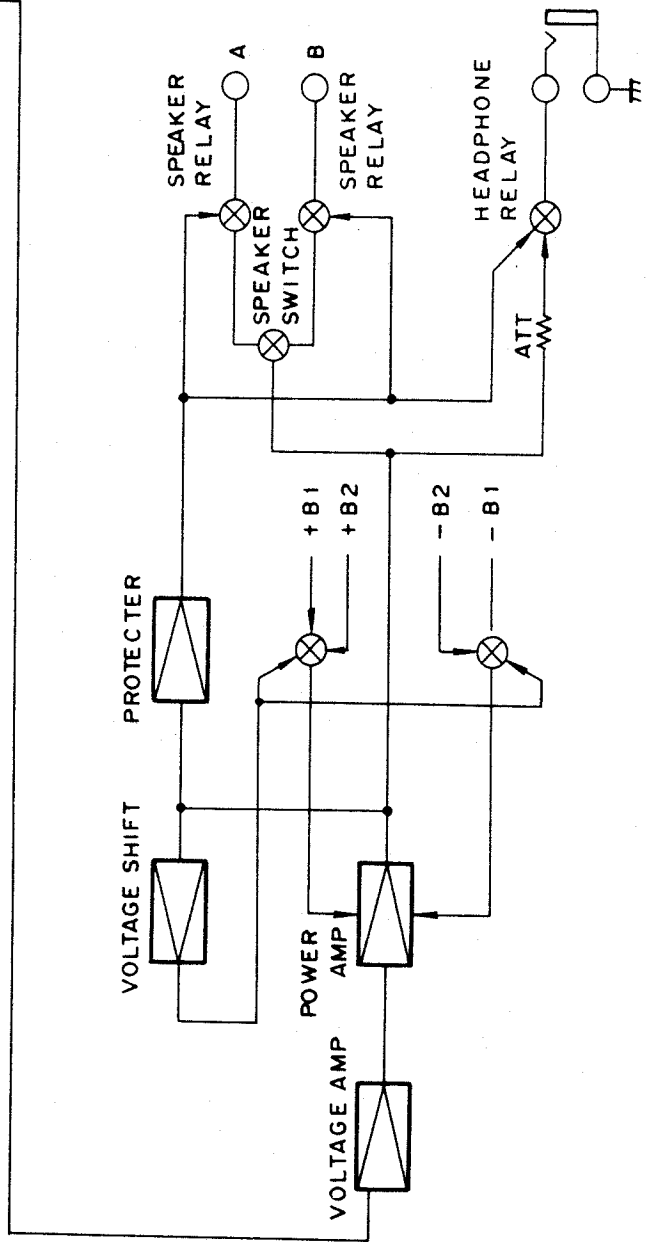
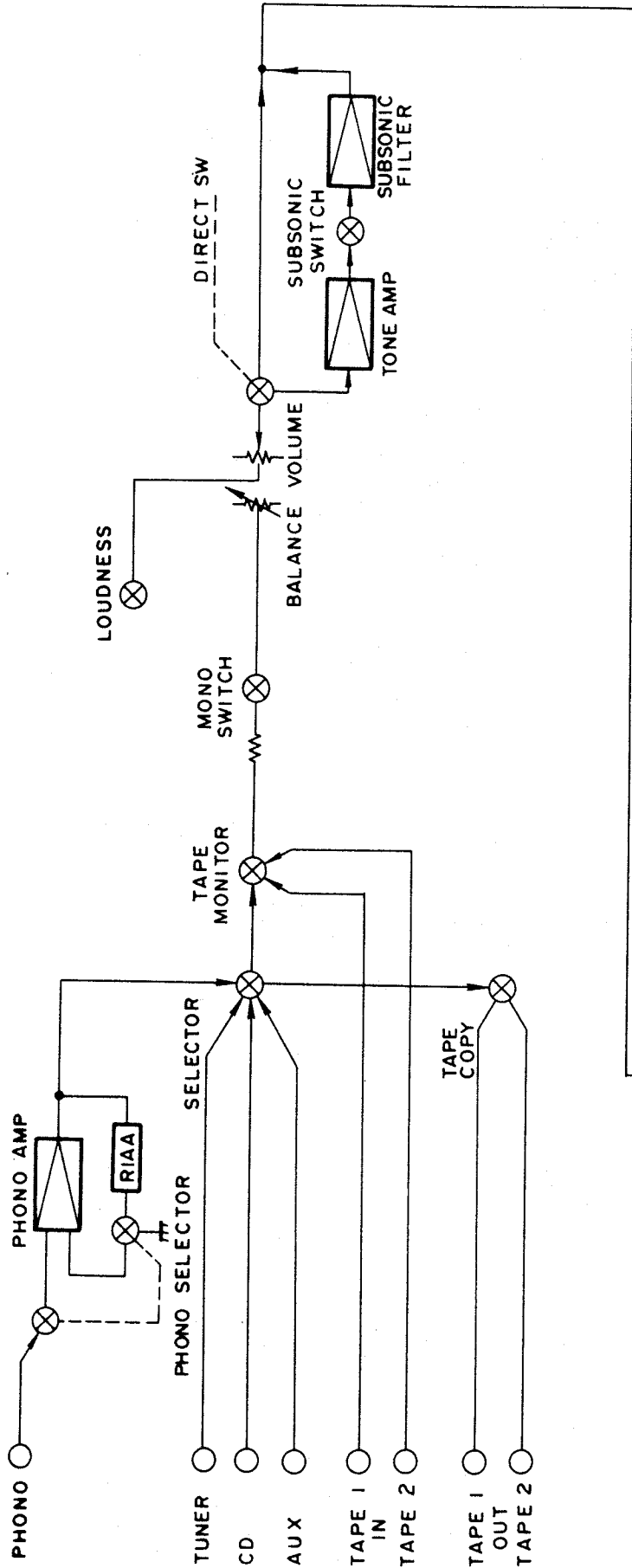

For Service Manuals Contact
 MAURITRON TECHNICAL SERVICES
 8 Cherry Tree Rd, Chinnor
 Oxon OX9 4QY
 Tel:- 01844-351694 Fax:- 01844-352554
 Email:- enquiries@mauritron.co.uk

M9633

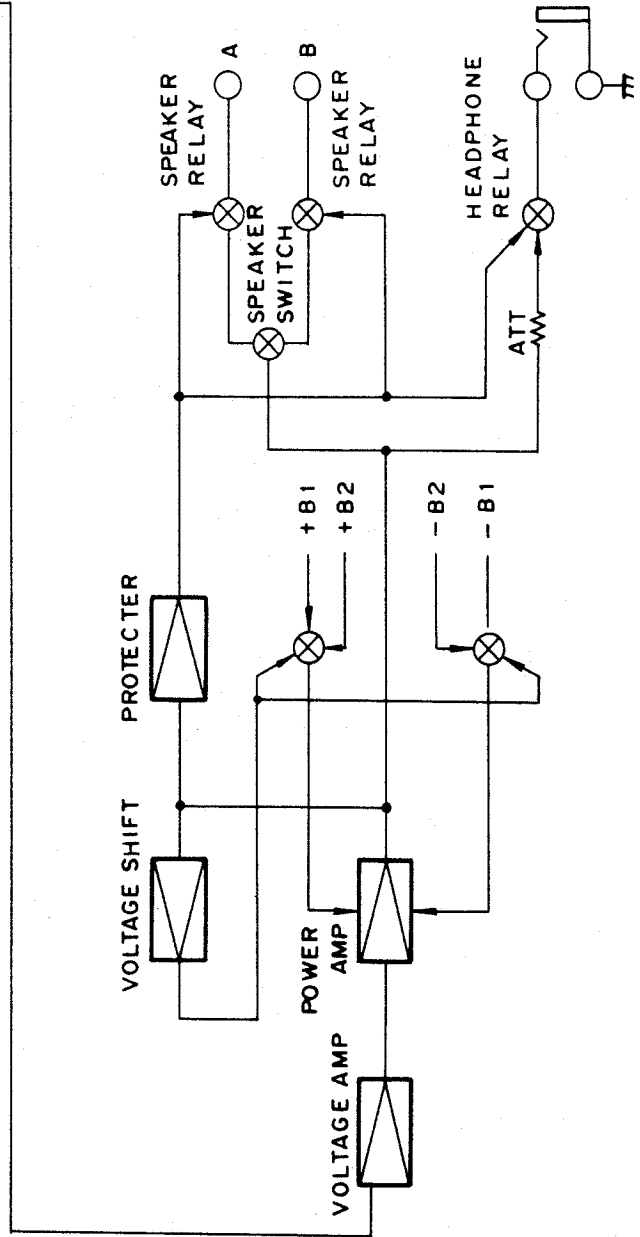
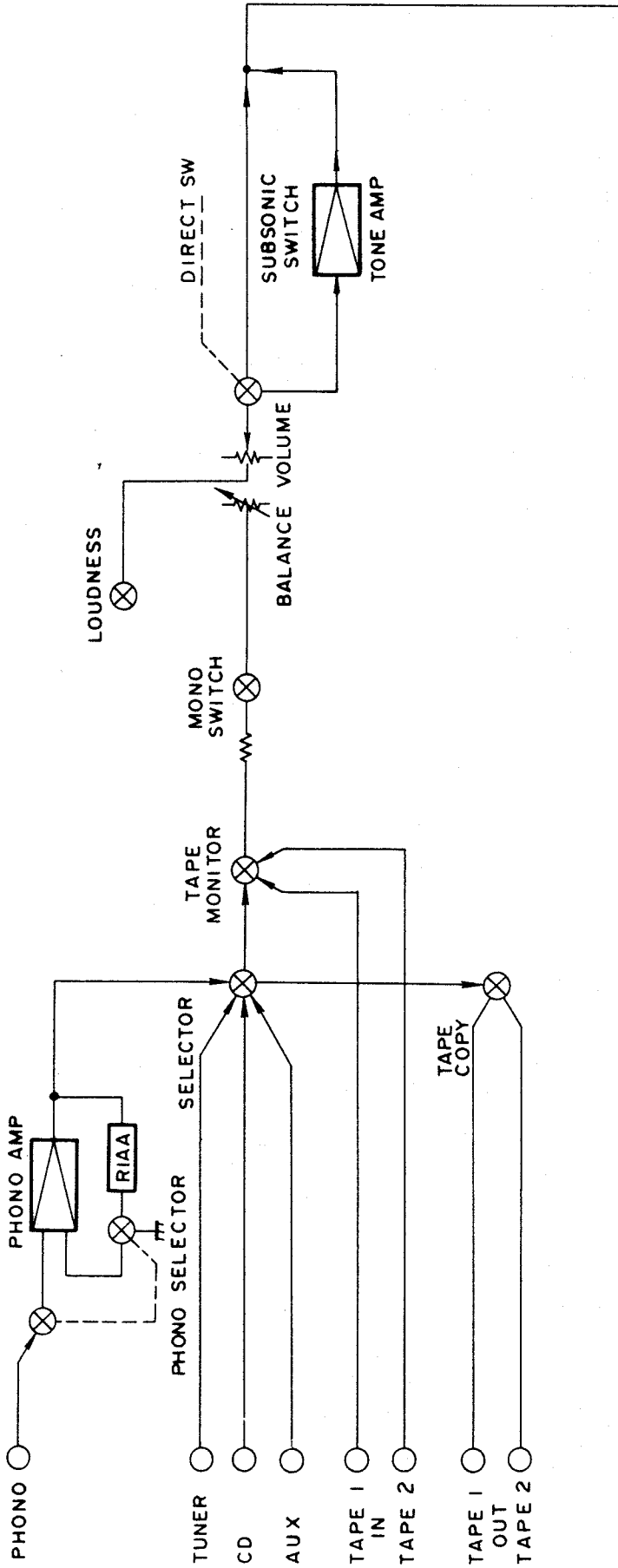

For Service Manuals Contact
 MAURITRON TECHNICAL SERVICES
 8 Cherry Tree Rd. Chinnor
 Oxon OX9 4QY
 Tel: 01844-351694 Fax: 01844-352554
 Email: enquiries@mauritron.co.uk

8. SCHEMATIC DIAGRAM AND COMPONENT LOCATIONS

8.2 Phono Amp/Input Jack (P401) Schematic Diagram and Component Locations

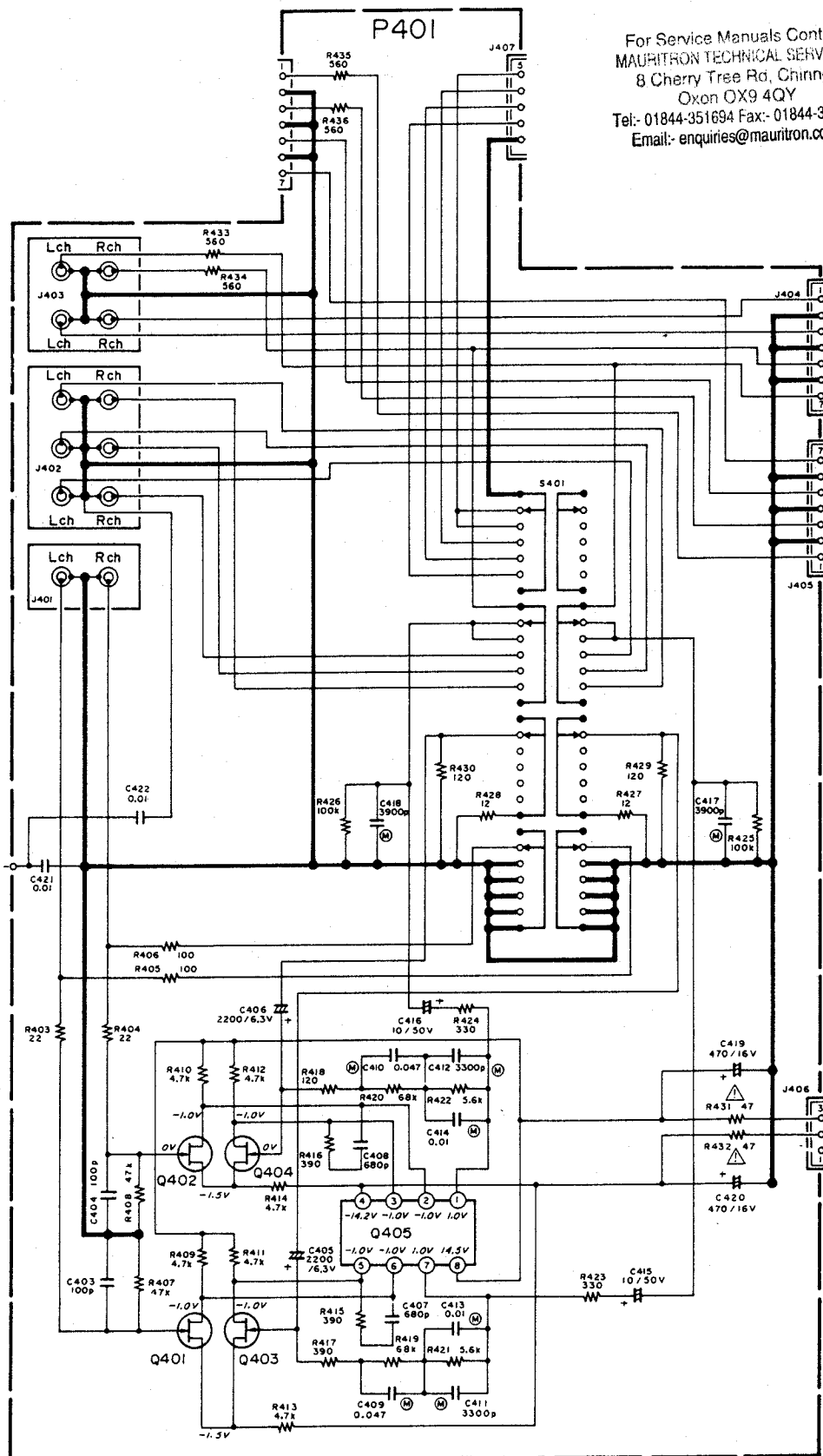

For Service Manuals Contact
MAURITRON TECHNICAL SERVICES
8 Cherry Tree Rd, Chinnor
Oxon OX9 4QY
Tel: 01844-351694 Fax: 01844-352554
Email: enquiries@mauritron.co.uk

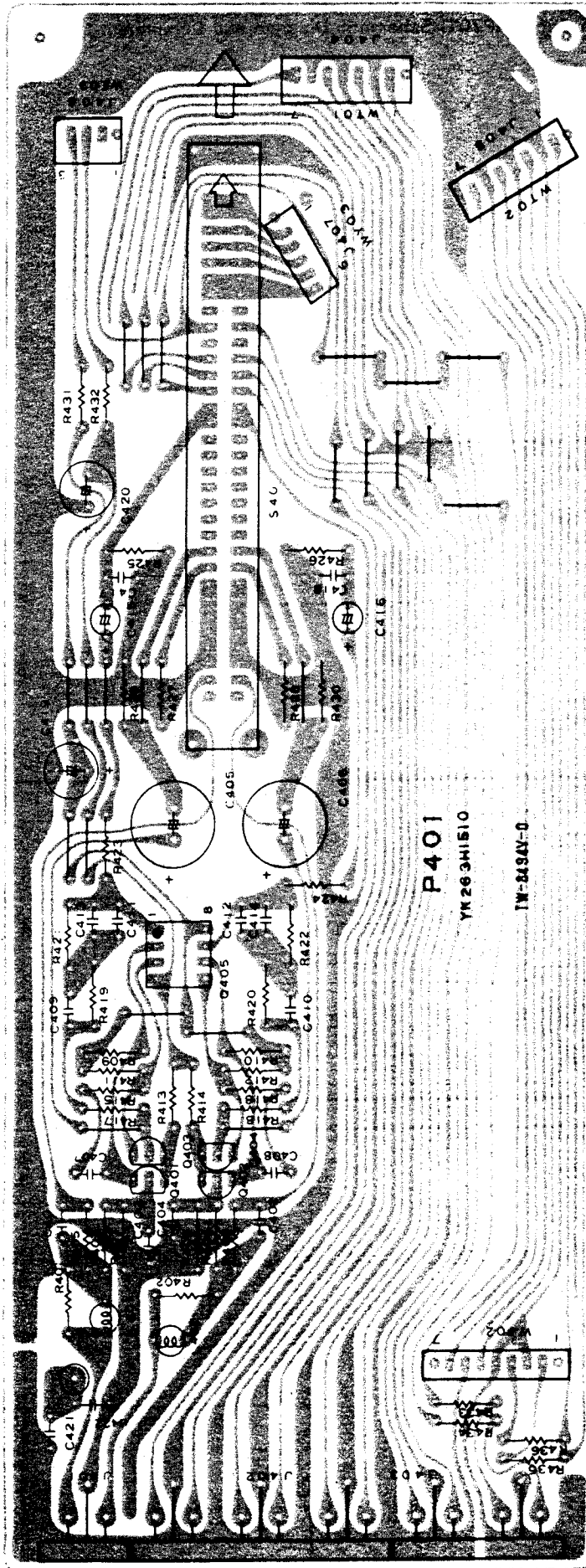

For Service Manuals Contact
 MAURITRON TECHNICAL SERVICES
 8 Cherry Tree Rd, Chinnor
 Oxon OX9 4QY
 Tel: 01844-351694 Fax: 01844-352554
 Email: enquiries@mauritron.co.uk

8.2 Main Amp/Power Supply (P701) Schematic Diagram and Component Locations

PM-64

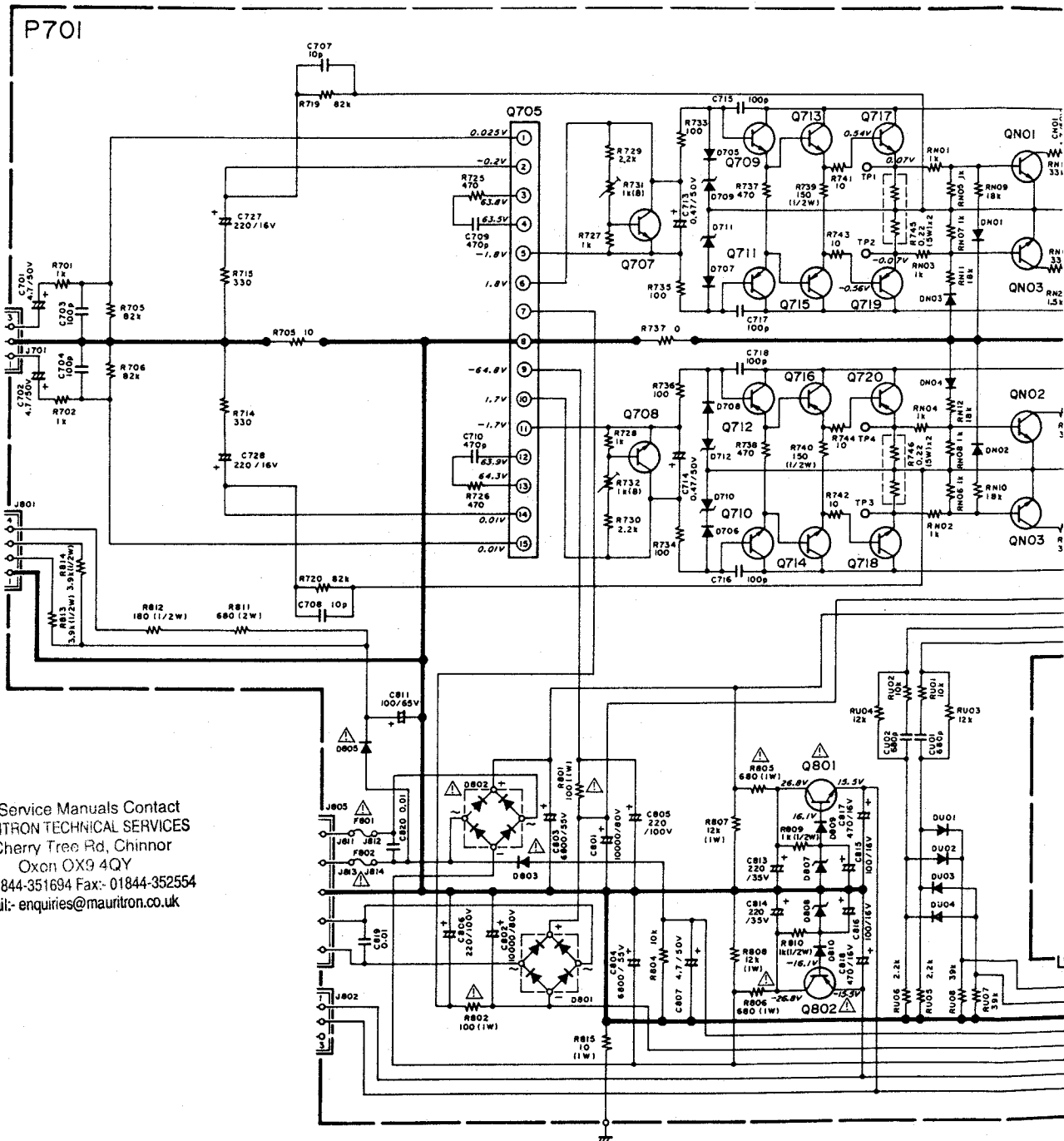

For Service Manuals Contact
 MAURITRON TECHNICAL SERVICES
 8 Cherry Tree Rd, Chinnor
 Oxon OX9 4QY
 Tel:- 01844-351694 Fax:- 01844-352554
 Email:- enquiries@mauritron.co.uk

For Service Manuals Contact
 MAURITRON TECHNICAL SERVICES
 8 Cherry Tree Rd. Chinnor
 Oxon OX9 4QY
 Tel:- 01844-351694 Fax:- 01844-352554
 Email:- enquiries@mauritron.co.uk

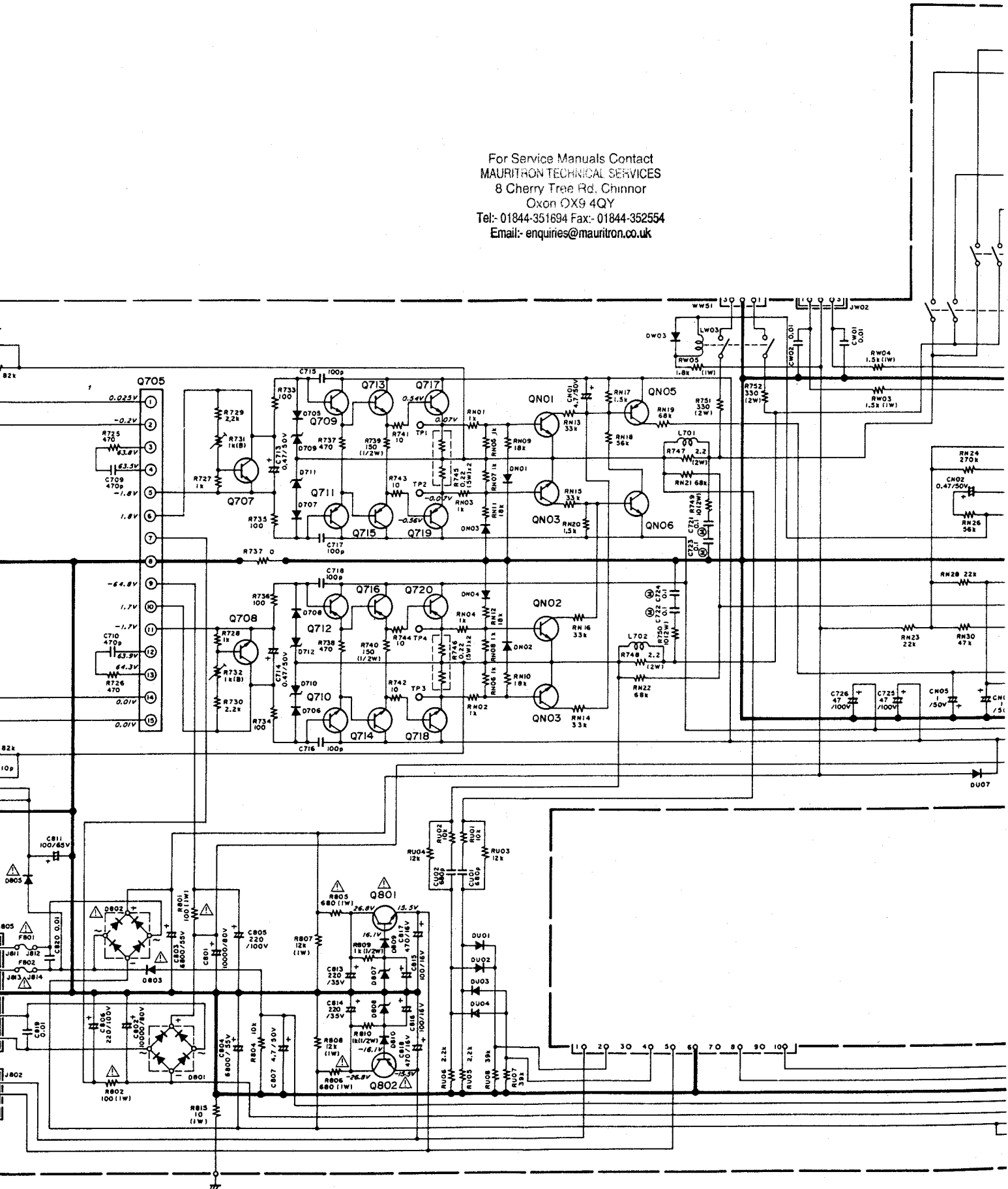

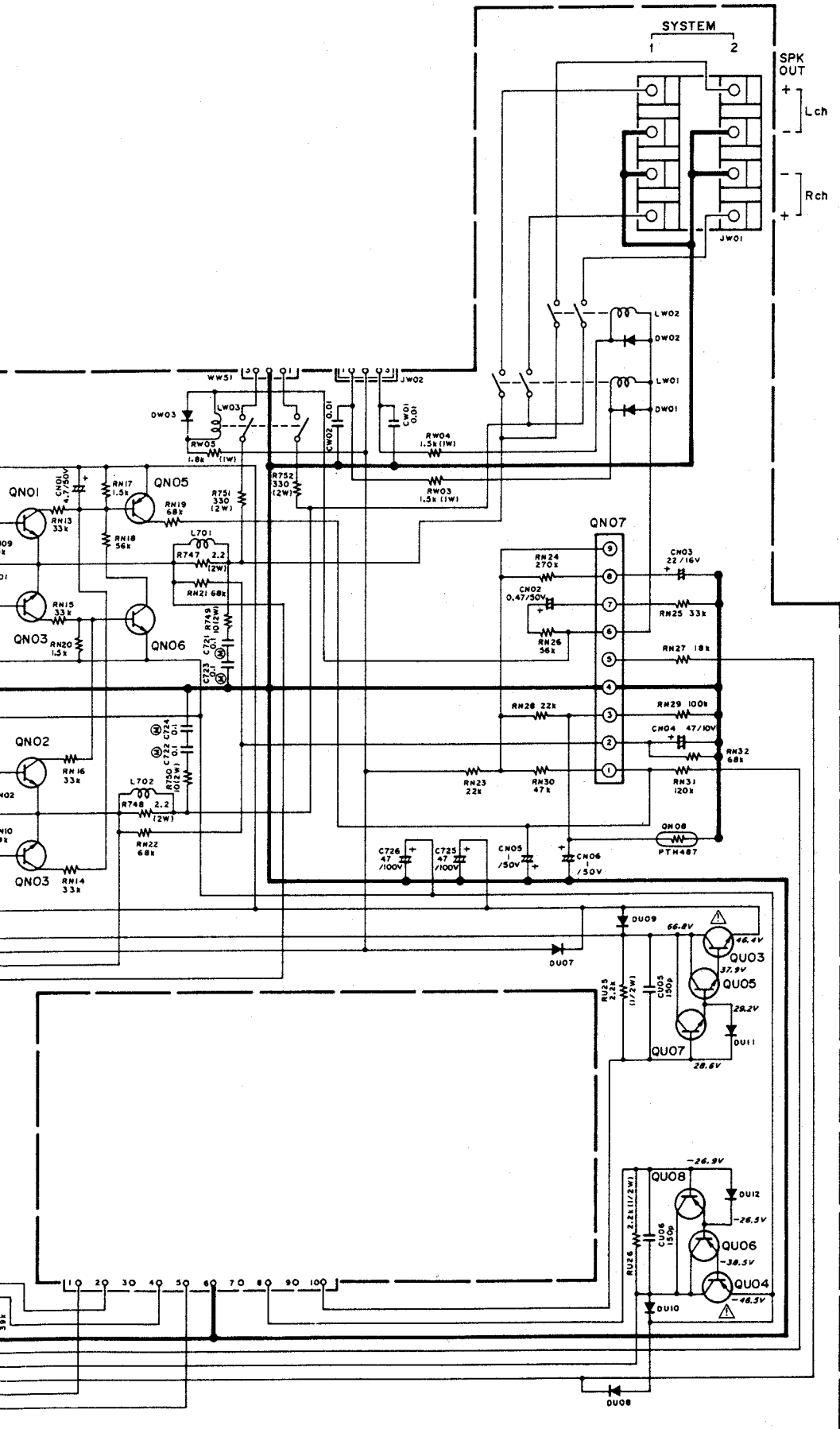

For Service Manuals Contact
MAURITRON TECHNICAL SERVICES
 8 Cherry Tree Rd, Chinnor
 Oxon OX9 4QY
 Tel:- 01844-351694 Fax:- 01844-352554
 Email:- enquiries@mauritron.co.uk

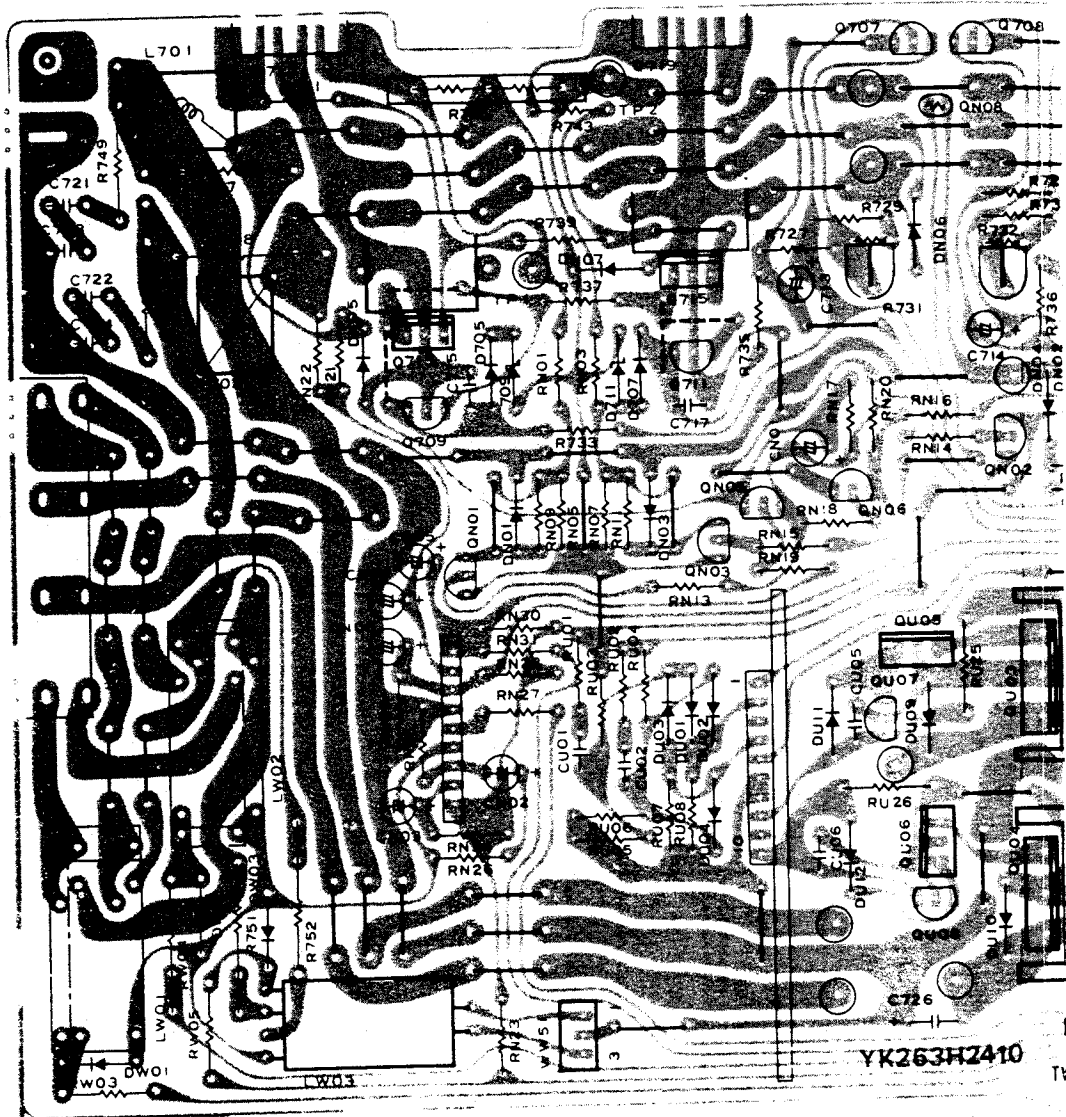

For Service Manuals Contact
MAURITRON TECHNICAL SERVICES
 8 Cherry Tree Rd, Chinnor
 Oxon OX9 4QY
 Tel:- 01844-351694 Fax:- 01844-352554
 Email:- enquiries@mauritron.co.uk

M9637

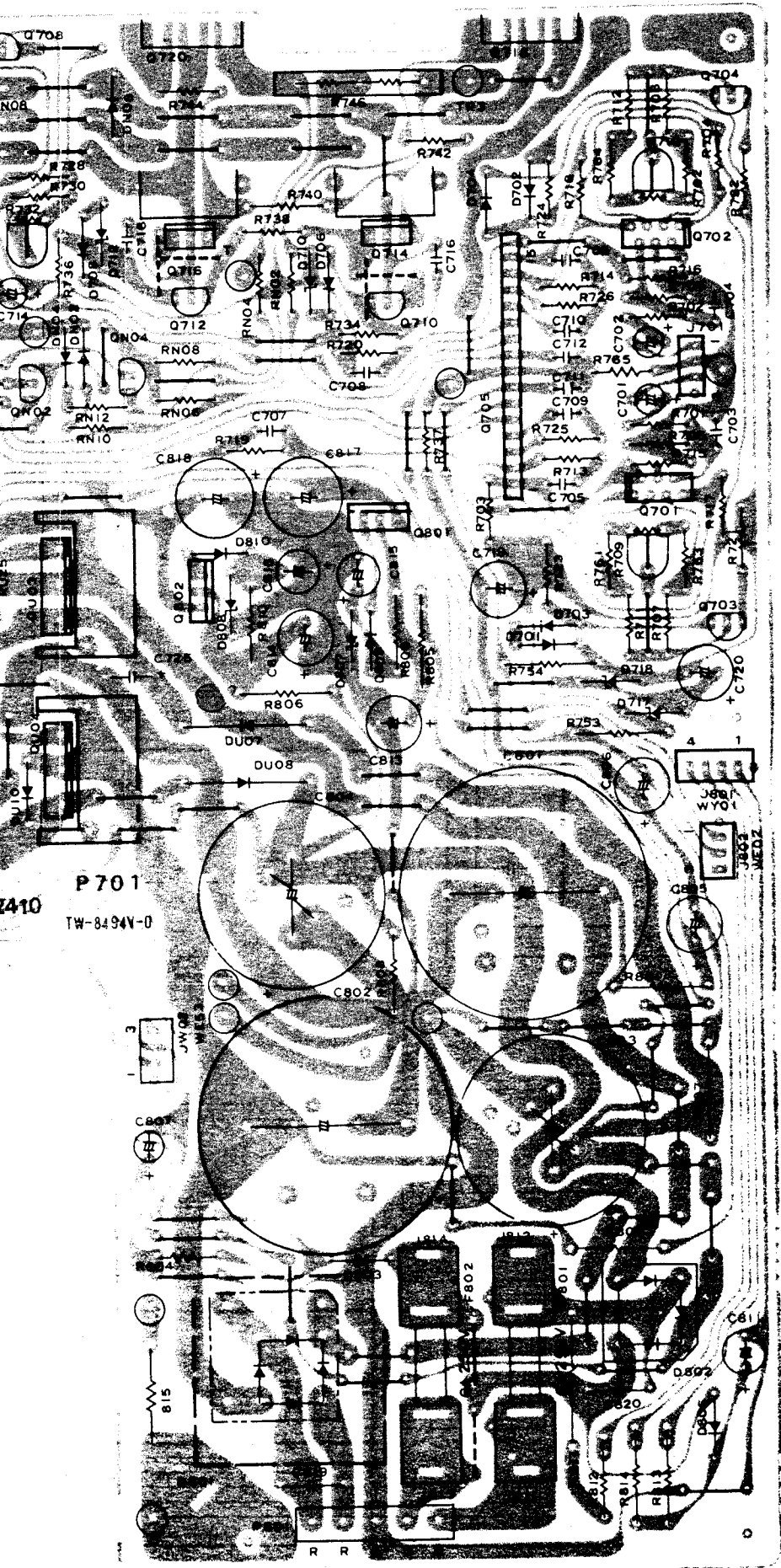

P701
TW-8494V-0

For Service Manuals Contact
MAURITRON TECHNICAL SERVICES
 8 Cherry Tree Rd, Chinnor
 Oxon OX9 4QY
 Tel: 01844-351694 Fax: 01844-352554
 Email: enquiries@maurtron.co.uk

8.2 Main Amp/Power Supply (P701) Schematic Diagram and Component Locations

PM-54

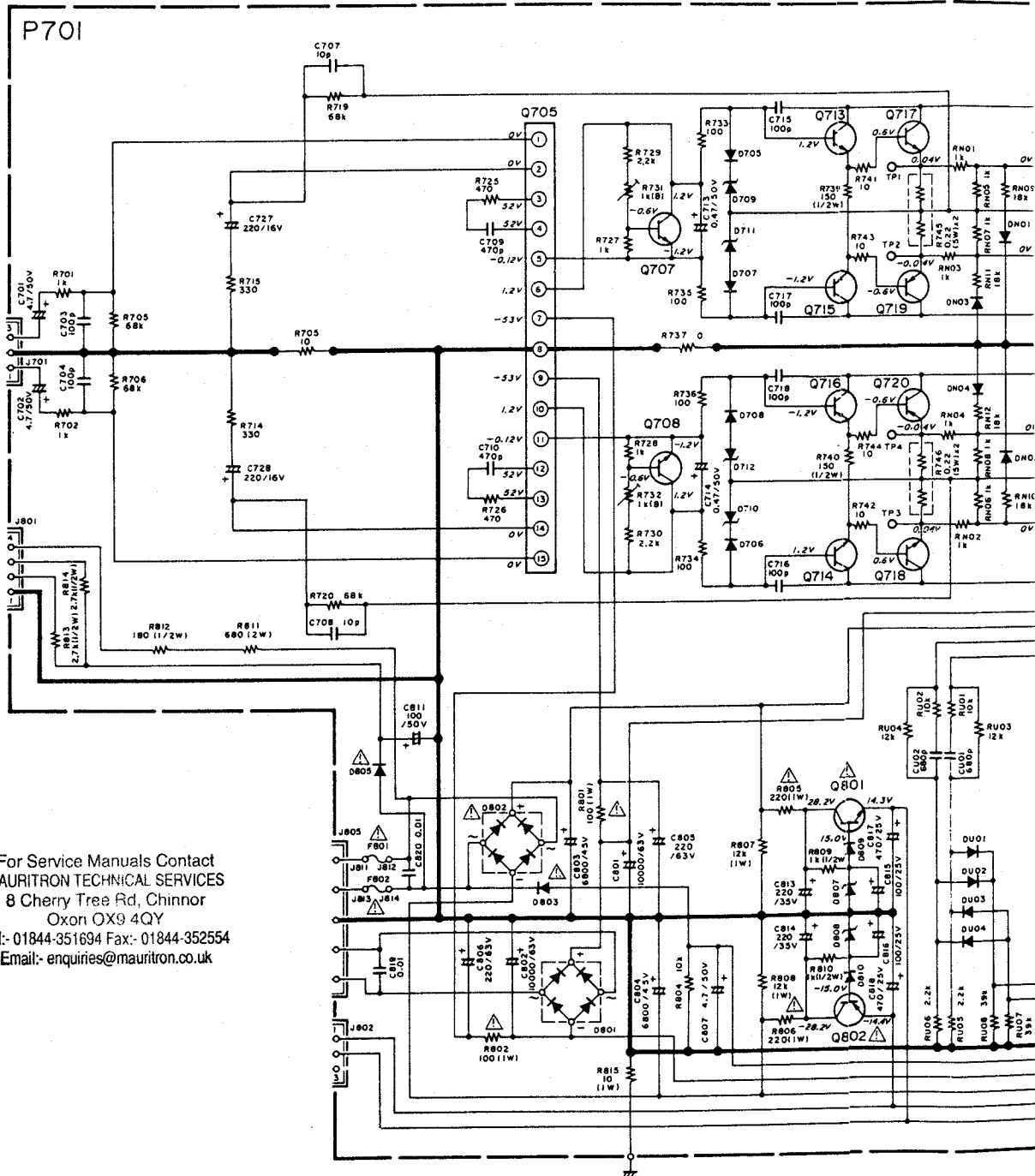

For Service Manuals Contact
MAURITRON TECHNICAL SERVICES
 8 Cherry Tree Rd, Chinnor
 Oxon OX9 4QY
 Tel: 01844-351694 Fax: 01844-352554
 Email: enquiries@mauritron.co.uk

Diagram and Component Locations

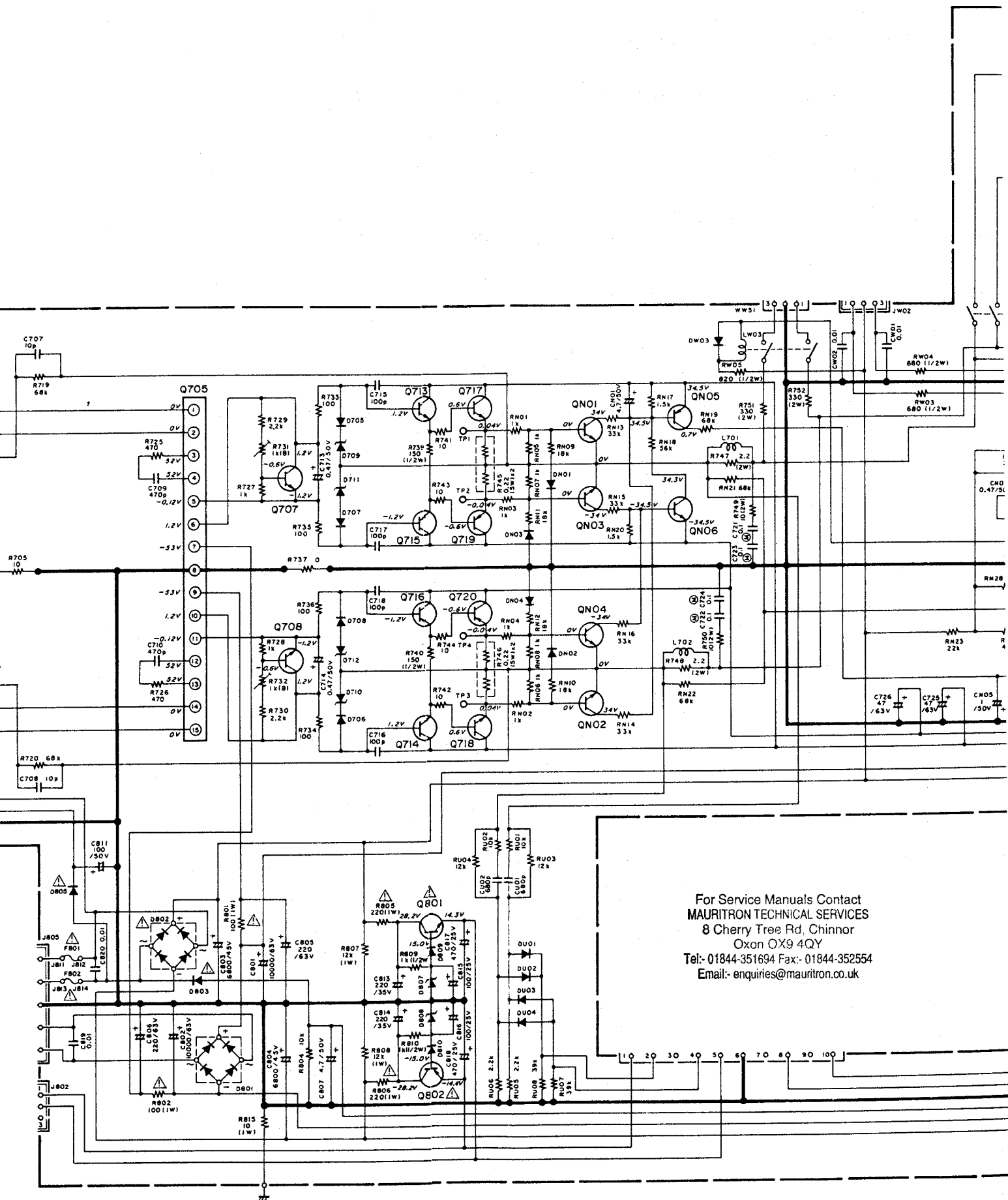

For Service Manuals Contact
MAURITRON TECHNICAL SERVICES
 8 Cherry Tree Rd, Chinnor
 Oxon OX9 4QY
 Tel:- 01844-351694 Fax:- 01844-352554
 Email:- enquiries@mauritron.co.uk

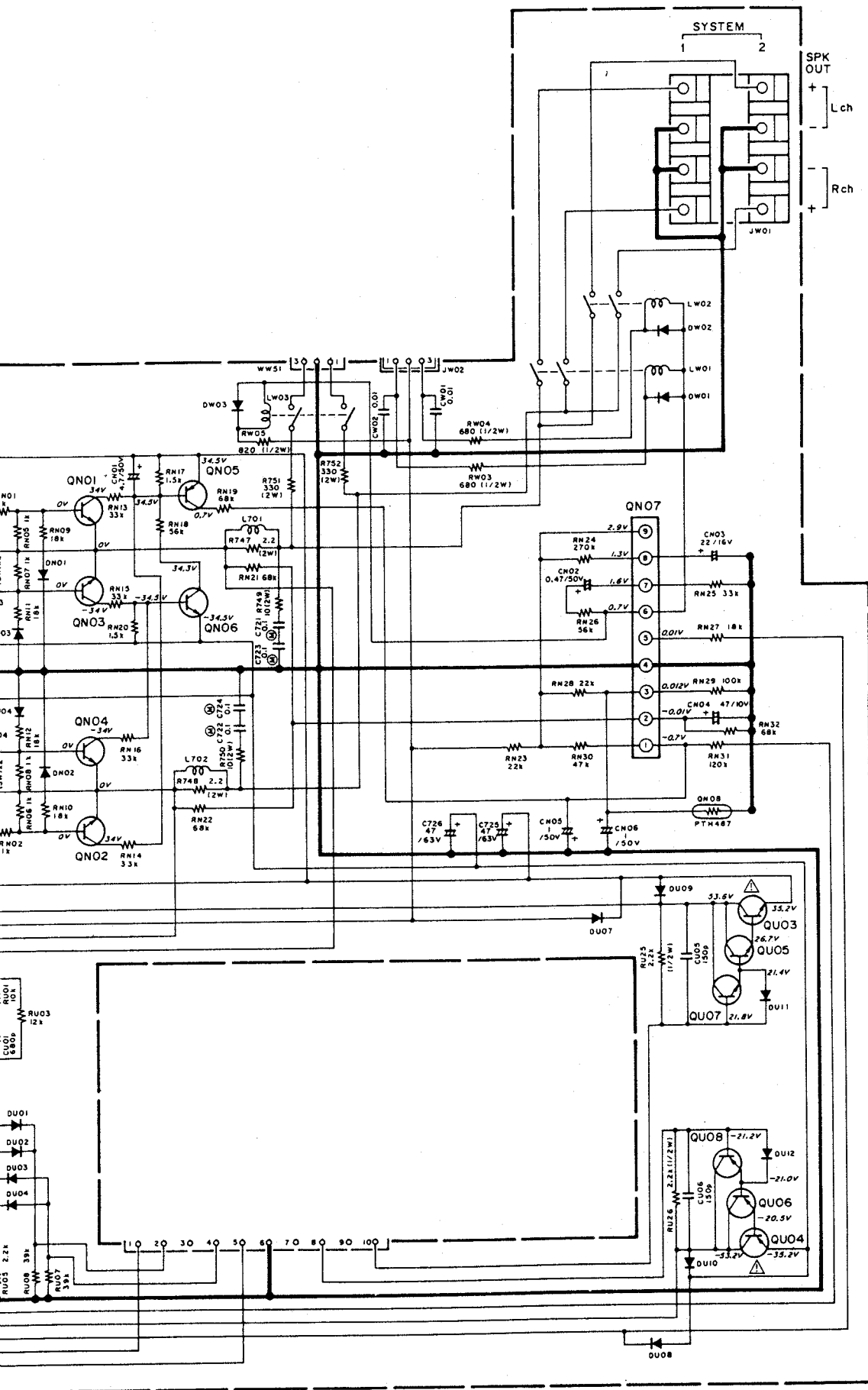

For Service Manuals Contact
MAURITRON TECHNICAL SERVICES
 8 Cherry Tree Rd, Chinnor
 Oxon OX9 4QY
 Tel: 01844-351694 Fax: 01844-352554
 Email: enquiries@mauritron.co.uk

8.3 Tone Amp (PE01) Schematic Diagram and Component Locations

PM-64

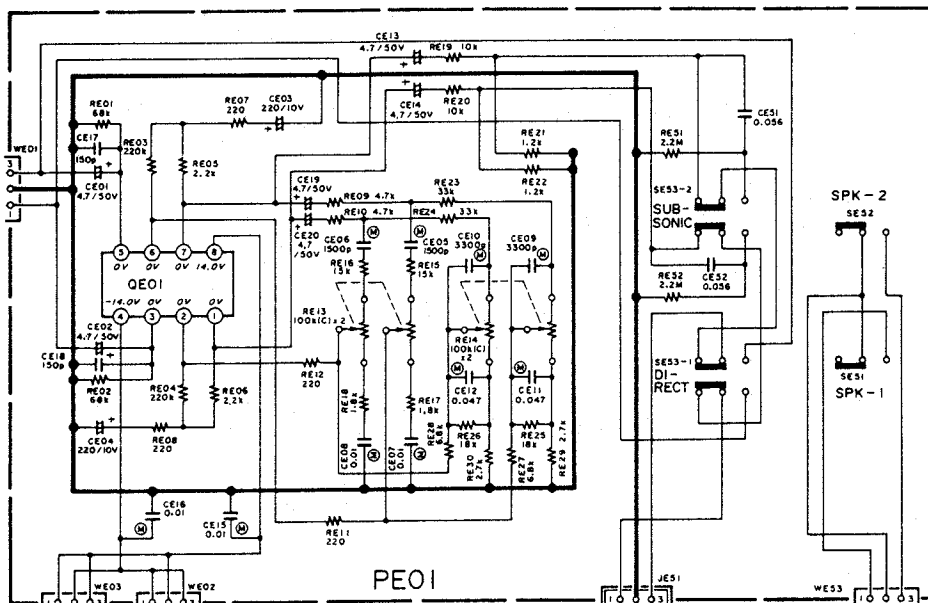

PM-54

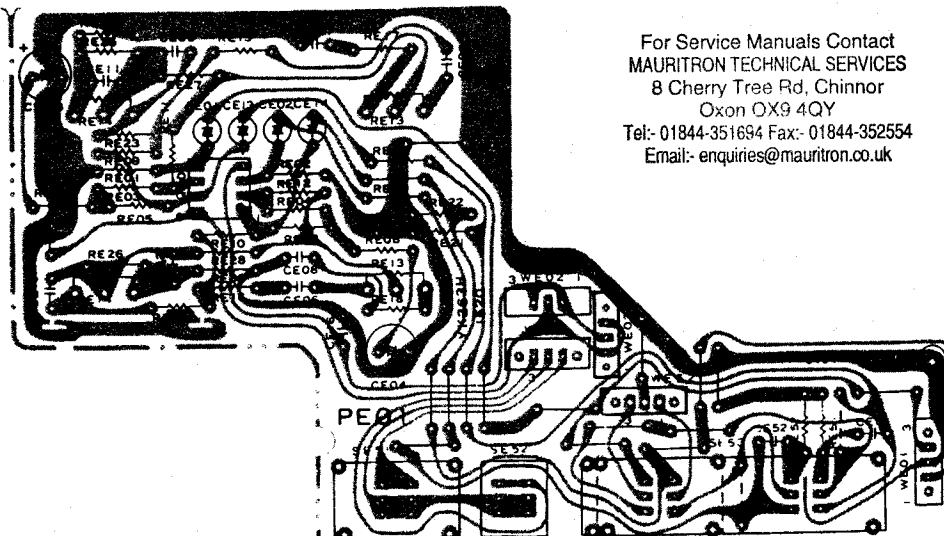
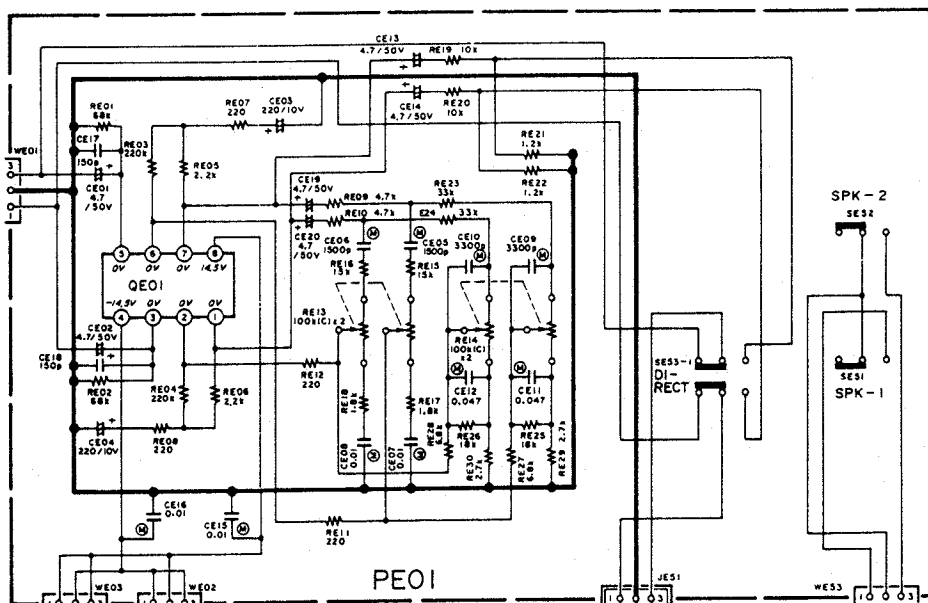

For Service Manuals Contact
 MAURITRON TECHNICAL SERVICES
 8 Cherry Tree Rd, Chinnor
 Oxon OX9 4QY
 Tel:- 01844-351694 Fax:- 01844-352554
 Email:- enquiries@mauritron.co.uk

8.4 Volume, Balance (PT01) Schematic Diagram and Component Locations

PM-64

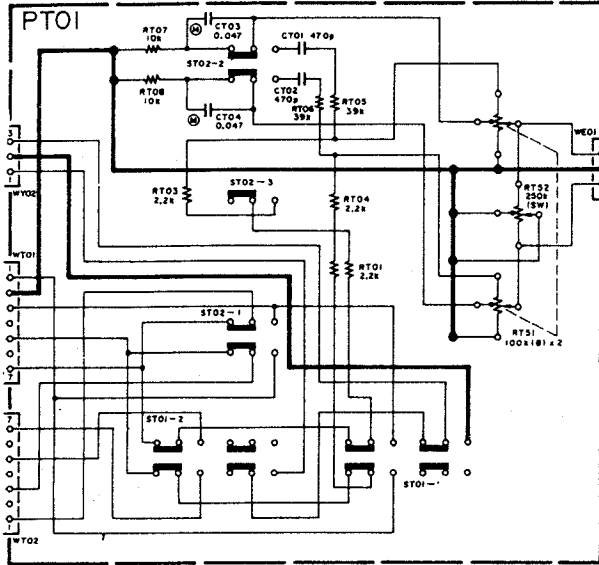

PM-54

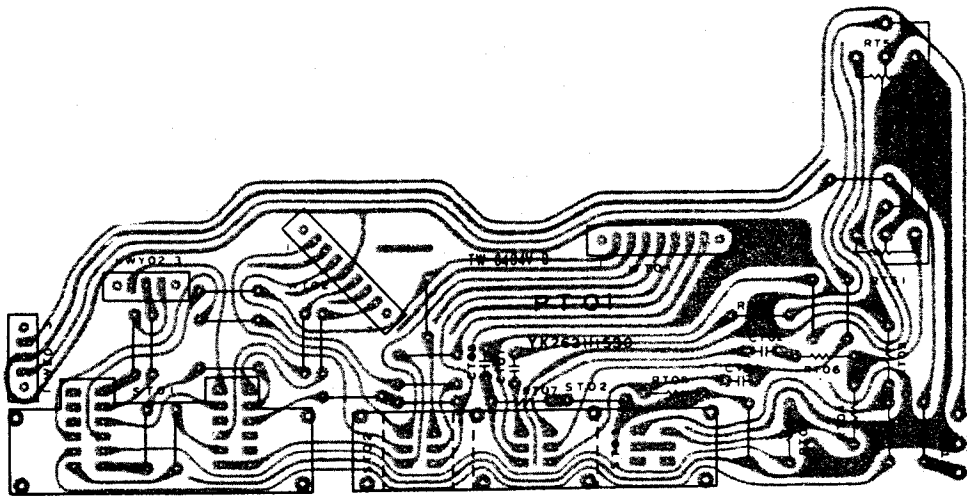
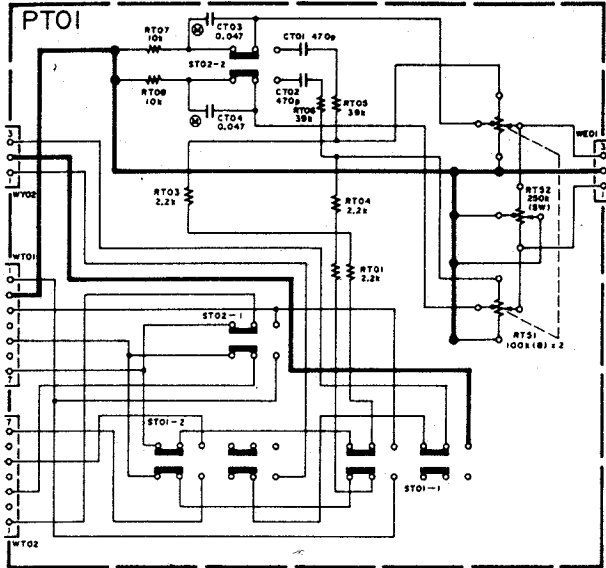

8.5 Power Switch (P851) Schematic Diagram and Component Locations

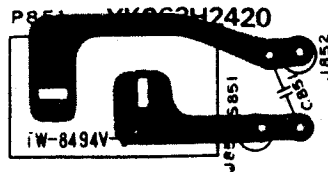
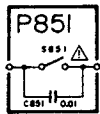

For Service Manuals Contact
 MAURITRON TECHNICAL SERVICES
 8 Cherry Tree Rd, Chinnor
 Oxon OX9 4QY
 Tel: 01844-351694 Fax: 01844-352554
 Email: enquiries@mauritron.co.uk

- (U) for U.S.A.
- (N) for Europe
- (A) for Australia
- (P) for PX
- (F) for Japan

REF. DESIG.	Q'TY					PART NO.	DESCRIPTION	REF. DESIG.	Q'TY					PART NO.	DESCRIPTION
	U	N	A	P	F				U	N	A	P	F		
A	1	1	1	1		263H248400	PM-64 FRONT PANEL Front Panel Assembly (Gold)	002C	2	2	2	2	2	51280308Z0	B.H. Tapped Screw B3×8
001C	1	1	1	1		263H248010	Front Panel	003C	2	2	2	2	2	51280308Z0	B.H. Tapped Screw B3×8
012C	1	1	1	1		263H113010	Stud	006C	2	2	2	2		263H154010	Knob (Gold) Vol./Input Selec.
015C	1	1	1	1		263H259010	Bushing	006C					2	263H154110	Knob (Black) Vol./Input Selec.
016C	1	1	1	1		242H259020	Bushing Power Switch	007C	2	2	2	2		263H154020	Knob (Gold) Tone Control
017C	5	5	5	5		242H259030	Bushing	007C					2	263H154120	Knob (Black) Tone Control
020C	1	1	1	1		263H067010	Cap Right	008C	1	1	1	1		263H154030	Knob (Gold) Balance
021C	1	1	1	1		263H067020	Cap Left	008C					1	263H154130	Knob (Black) Balance
022C	1	1	1	1		263H151010	Introducer	009C	1	1	1	1		242H270010	Button (Gold) Power
023C	1	1	1	1		263H158010	Window	009C					1	242H270110	Button (Black) Power
024C	1	1	1	1		242H151020	Introducer AVSS	025C	4	4	4	4		263H115010	Spring Button
A1					1	263H248410	Front Panel Assembly (Black)	010C	4	4	4	4		263H270010	(PM-64 ONLY) Button (Gold) Direct/Subsonic/Tape Monitor 1, 2
001C					1	263H248020	Front Panel	010C					4	263H270110	Button (Black) Direct/Subsonic/Tape Monitor 1, 2
012C					1	263H113110	Stud	011C	5	5	5	5		263H270020	Button (Gold) Speaker 1, 2/ Loudness, etc.
015C					1	263H259110	Bushing	011C					5	263H270120	Button (Black) Speaker 1, 2/ Loudness, etc.
016C					1	242H259120	Bushing Power Switch	010C	3	3	3			263H270010	(PM-54 ONLY) Button (Gold) Direct/Tape Monitor
017C					5	242H259130	Bushing	010C					3	263H270110	Button (Black) Direct/Tape Monitor
020C					1	263H067110	Cap Right	011C	4	4	4			263H270020	Button (Gold) Speaker/Loudness, etc.
021C					1	263H067120	Cap Left	011C					4	263H270120	Button (Black) Speaker/ Loudness, etc.
022C					1	263H151010	Introducer	001G	1	1	1	1		263H105010	Chassis Front
023C					1	263H158010	Window	002G	7	7	7	7		51280308B0	B.H. Tapped Screw B3×8
024C					1	242H151120	Introducer	003G	8	8	8	8		51100306A9	B.H.M. Screw B3×6
A	1	1	1			264H248400	PM-54 FRONT PANEL Front Panel Assembly (Gold)	004G	2	2	2	2		51100306Z9	B.H.H. Screw B3×6
001C	1	1	1			264H248010	Front Panel	017G	1	1	1	1		263H051010	Guide L.E.D.
012C	1	1	1			242H113010	Stud	021G	3	3	3			51280308B0	B.H. Tapped Screw B3×8
015C	1	1	1			242H259010	Bushing	021G					3	51280308Z0	B.H. Tapped Screw B3×8
016C	1	1	1			242H259020	Bushing	016E	1					105H861010	Label 3 Year ESC
017C	4	4	4			242H259030	Bushing								
020C	1	1	1			263H067010	Cap Right								
021C	1	1	1			263H067020	Cap Left								
022C	1	1	1			263H151010	Introducer								
023C	1	1	1			263H158010	Window								
024C	1	1	1			244H151020	Introducer								
A1					1	264H248410	Front Panel Assembly (Black)								
001C					1	264H248020	Front Panel								
012C					1	242H113110	Stud								
015C					1	242H259110	Bushing								
016C					1	242H259120	Bushing								
017C					4	242H259130	Bushing								
020C					1	263H067110	Cap Right								
021C					1	263H067120	Cap Left								
022C					1	263H151010	Introducer								
023C					1	263H158010	Window								
024C					1	242H151120	Introducer								

For Service Manuals Contact
MAURITRON TECHNICAL SERVICES
 8 Cherry Tree Rd, Chinnor
 Oxon OX9 4QY
 Tel:- 01844-351694 Fax:- 01844-352554
 Email:- enquiries@mauritron.co.uk

M9643

[P02-99] Rear Panel

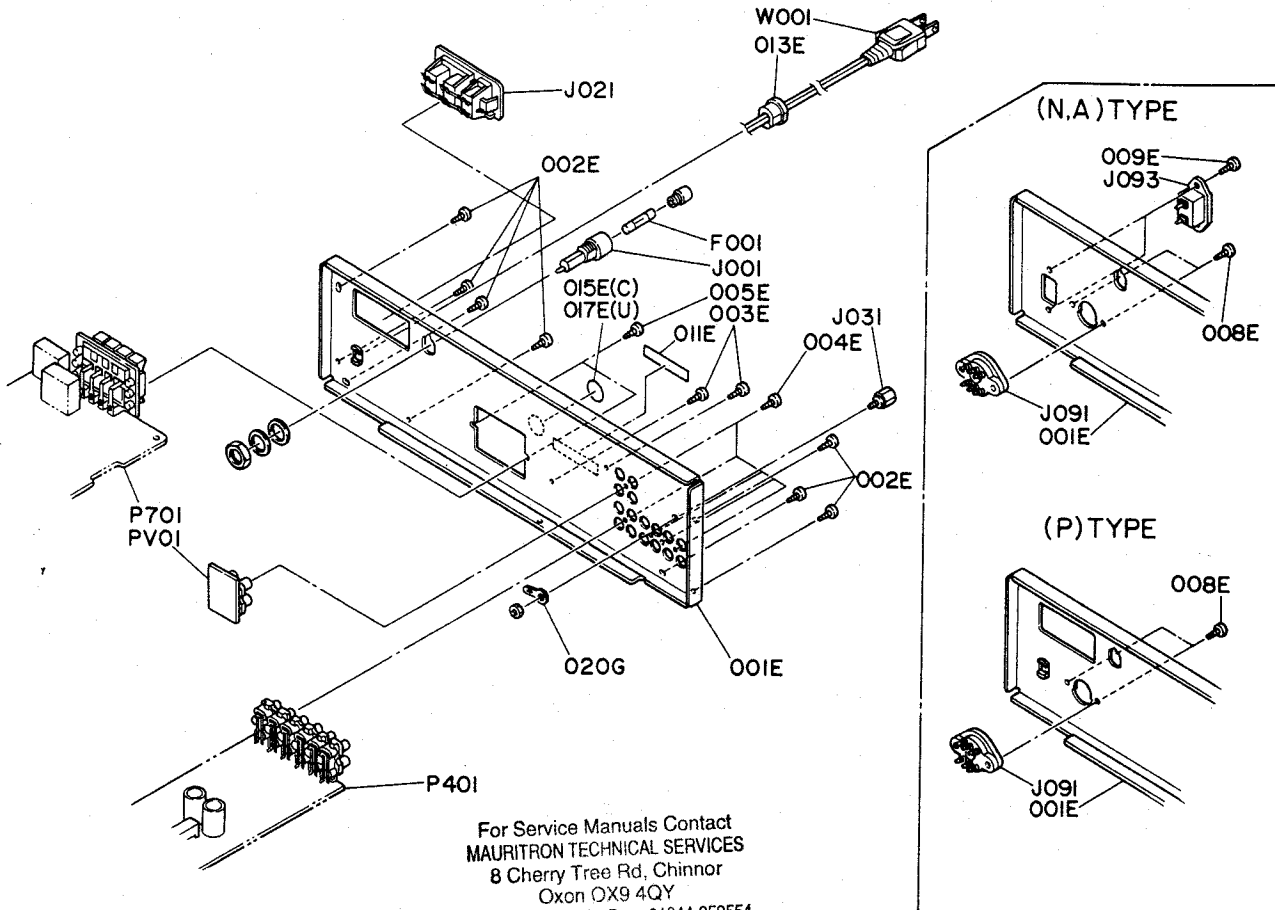

For Service Manuals Contact
 MAURITRON TECHNICAL SERVICES
 8 Cherry Tree Rd, Chinnor
 Oxon OX9 4QY
 Tel:- 01844-351694 Fax:- 01844-352554
 Email:- enquiries@mauritron.co.uk

- (U) for U.S.A.
- (N) for Europe
- (A) for Australia
- (P) for PX
- (F) for Japan

REF. DESIG.	Q'TY					PART NO.	DESCRIPTION	REF. DESIG.	Q'TY					PART NO.	DESCRIPTION
	U	N	A	P	F				U	N	A	P	F		
001E	1	1				263H250020	Rear Panel (PM-64)	Δ F001	1	1				FS10258000	Fuse 2.5A (PM-64)
001E					1	263H250010	Rear Panel (PM-64)	Δ F001				1	1	FS10800600	Fuse 8A (PM-64)
001E				1		263H250030	Rear Panel (PM-64)	Δ F001	1					FS10500500	Fuse 5A (PM-64)
001E	1					263H250040	Rear Panel (PM-64)	Δ F001	1	1				FS10200800	Fuse 2A (PM-54)
001E				1		264H250010	Rear Panel (PM-54)	Δ F001				1		FS10500600	Fuse 5A (PM-54)
001E	1	1				264H250020	Rear Panel (PM-54)	Δ F001	1					FS10500500	Fuse 5A (PM-54)
001E	1					264H250040	Rear Panel (PM-54)								
002E	7	7	7	7		51280308B0	B.H. Tapped Screw B3×8	Δ J001	1	1	1			YJ08000290	Jack, Fuse Holder
002E					7	51280308Z0	B.H. Tapped Screw B3×8	Δ J001	1				1	YJ08000300	Jack, Fuse Holder
003E	2	2	2	2		51280308B0	B.H. Tapped Screw B3×8	Δ J021	1			1	1	YJ04001100	Jack, AC Outlet
003E					2	51280308Z0	B.H. Tapped Screw B3×8	Δ J031	1	1	1	1	1	YT01010050	Terminal, Ground
004E	5	5	5	5		51280308B0	B.H. Tapped Screw B3×8	Δ J091	1	1	1			BY05080050	Voltage Selector
004E					5	51280308Z0	B.H. Tapped Screw B3×8	Δ J093	1	1				YPO4000610	AC Inlet
005E	2	2	2	2		51280308B0	B.H. Tapped Screw B3×8	Δ W001					1	YC01800200	AC Power Cord
005E					2	51280308Z0	B.H. Tapped Screw B3×8	Δ W001	1				1	YC01800260	AC Power Cord
008E	2	2	2			51280308B0	B.H. Tapped Screw B3×8								
008E					2	51280308Z0	B.H. Tapped Screw B3×8								
009E	2	2				51280308B0	B.H. Tapped Screw B3×8								
011E	1	1		1		2112265110	Indicator Serial Label								
011E	1					2112265010	Indicator Serial Label								
013E	1			1	1	1455259090	Bushing								
015E	1					2457861040	Label CSA								
017E	1					9511101070	Label UL								
020G	1	1	1	1	1	62040029WD	Lug GND								

[P03-99] Lid and General Parts

For Service Manuals Contact
MAURITRON TECHNICAL SERVICES
 8 Cherry Tree Rd, Chinnor
 Oxon OX9 4QY
 Tel: 01844-351694 Fax: 01844-352554
 Email: enquiries@mauritron.co.uk

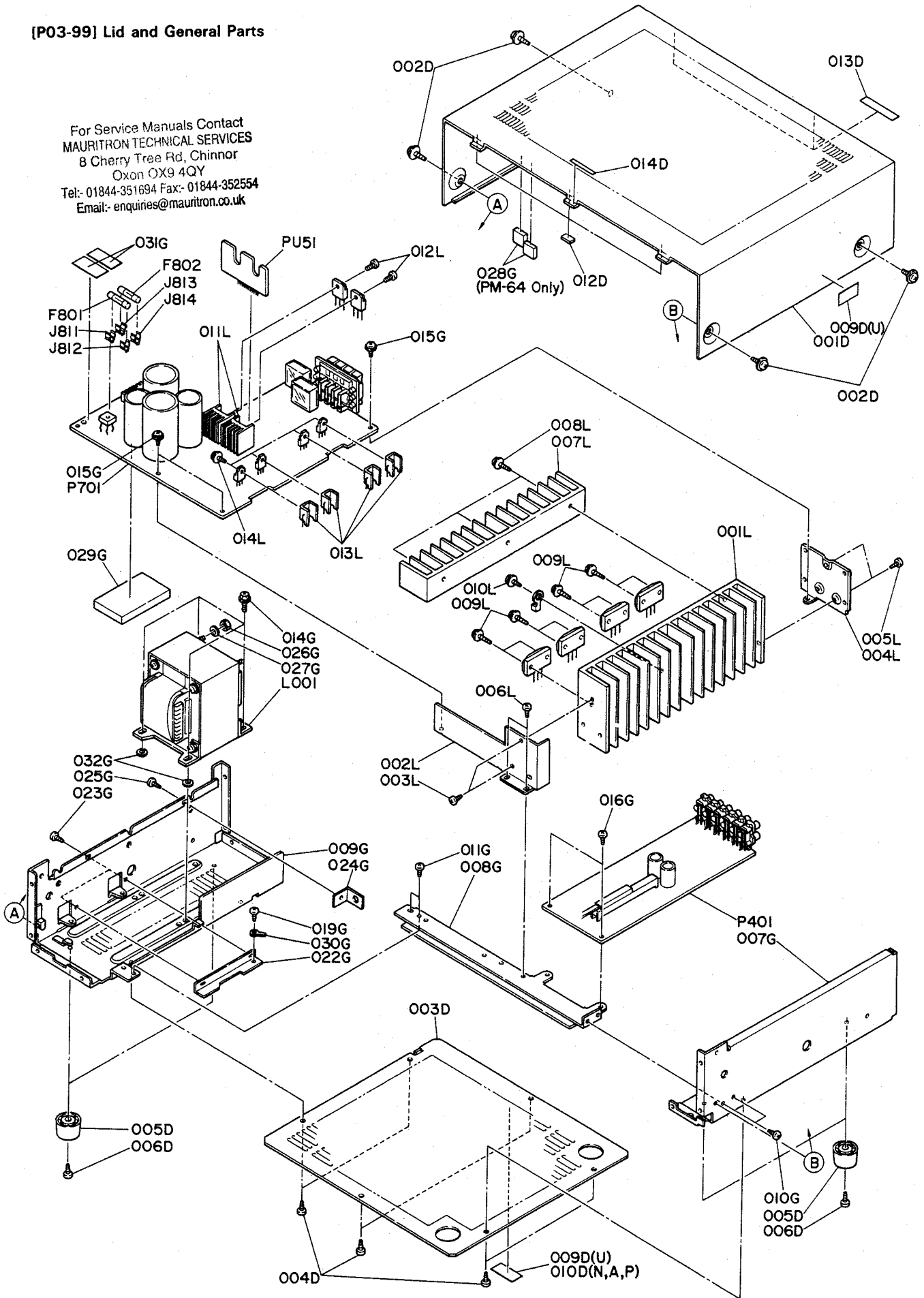

- (U) for U.S.A. • (P) for PX
- (N) for Europe • (E) for Japan
- (A) for Australia

REF. DESIG.	QTY					PART NO.	DESCRIPTION	REF. DESIG.	QTY					PART NO.	DESCRIPTION
	U	N	A	P	F				U	N	A	P	F		
001D	1	1	1	1		263H257030	Top Cover (Gold)	001L	1	1	1	1	1	263H267010	Heat Sink
001D					1	263H257040	Top Cover (Black)	002L	1	1	1	1	1	263H160030	Bracket
002D	4	4	4	4	4	51260408Z0	B.T. Screw B4x8	003L	2	2	2	2	2	51280308B0	B.H. Tapped Screw B3x8
003D	1	1	1	1	1	263H257020	Bottom Cover	004L	1	1	1	1	1	263H160020	Bracket
004D	6	6	6	6		51280308B0	B.H. Tapped Screw B3x8	005L	2	2	2	2	2	51280308B0	B.H. Tapped Screw B3x8
004D					6	51280308Z0	B.H. Tapped Screw B3x8	006L	2	2	2	2	2	51280308B0	B.H. Tapped Screw B3x8
005D	4	4	4	4	4	2759057010	Leg	007L	1	1	1	1	1	263H267030	Heat Sink (PM-64 Only)
006D	4	4	4	4	4	51280410B0	B.H. Tapped Screw B4x10	008L	3	3	3	3	3	51780315B0	Fin Neck B.T. Screw B3x15
009D		1	1	1		2911861140	Label	009L	8	8	8	8	8	51780315B0	Fin Neck B.T. Screw B3x15
009D	2					117H861010	Label								
010D		1	1	1		2911861110	Label	010L	1	1	1	1	1	51780315B0	Fin Neck B.T. Screw B3x15
012D					3	242H118010	Spacer	011L	2	2	2	2	2	263H267040	Heat Sink
013D					2	2965118010	Spacer	012L	2	2	2	2	2	51100308A9	B.H.M. Screw B3x8
014D					1	2964056010	Buffer	013L	4	4	4	4	4	250H267020	Heat Sink (PM-64 Only)
007G	1	1	1	1	1	263H105020	Chassis, Right	014L	4	4	4	4	4	51260308B0	B.T. Screw B3x8 (PM-64 Only)
008G	1	1	1	1	1	263H160010	Bracket	Δ L001		1	1	1		TS19620060	Power Transformer (PM-64)
009G	1	1	1	1	1	263H105030	Chassis, Left	Δ L001					1	TS19620040	Power Transformer (PM-64)
010G	2	2	2	2	2	51280308B0	B.H. Tapped Screw B3x8	Δ L001	1					TS19620050	Power Transformer (PM-64)
011G	2	2	2	2	2	51280308B0	B.H. Tapped Screw B3x8	Δ L001		1	1			TS19616050	Power Transformer (PM-54)
014G	4	4	4	4	4	52040408A0	H. Head Bolt	Δ L001					1	TS19616030	Power Transformer (PM-54)
015G	3	3	3	3	3	51260308B0	B.T. Screw B3x8	Δ L001	1					TS19616040	Power Transformer (PM-54)
016G	2	2	2	2	2	51260308B0	B.T. Screw B3x8								
019G	1	1	1	1		51280308B0	B.H. Tapped Screw B3x8								
019G					1	51280308Z0	B.H. Tapped Screw B3x8								
022G	1	1	1	1	1	263H104010	Retainer								
023G	2	2	2	2		51280308B0	B.H. Tapped Screw B3x8								
023G					2	51280308Z0	B.H. Tapped Screw B3x8								
024G	1	1	1	1	1	263H104020	Retainer								
025G	1	1	1	1		51280308B0	B.H. Tapped Screw B3x8								
025G					1	51280308Z0	B.H. Tapped Screw B3x8								
026G	1	1	1	1	1	53110503A9	Hexagon Nut								
027G	1	1	1	1	1	54020501A0	Flat Washer, P.								
028G	2	2	2	2	2	263H056010	Buffer Top Cover (PM-64)								
029G	1	1	1	1	1	263H056020	Buffer								
030G	1	1	1	1	1	62030049W0	Lug								
031G	2				2	9510611050	Label.Fuse								

For Service Manuals Contact
 MAURITRON TECHNICAL SERVICES
 8 Cherry Tree Rd, Chinnor
 Oxon OX9 4QY
 Tel:- 01844-351694 Fax:- 01844-352554
 Email:- enquiries@mauriron.co.uk

[H01-99] Packing Materials

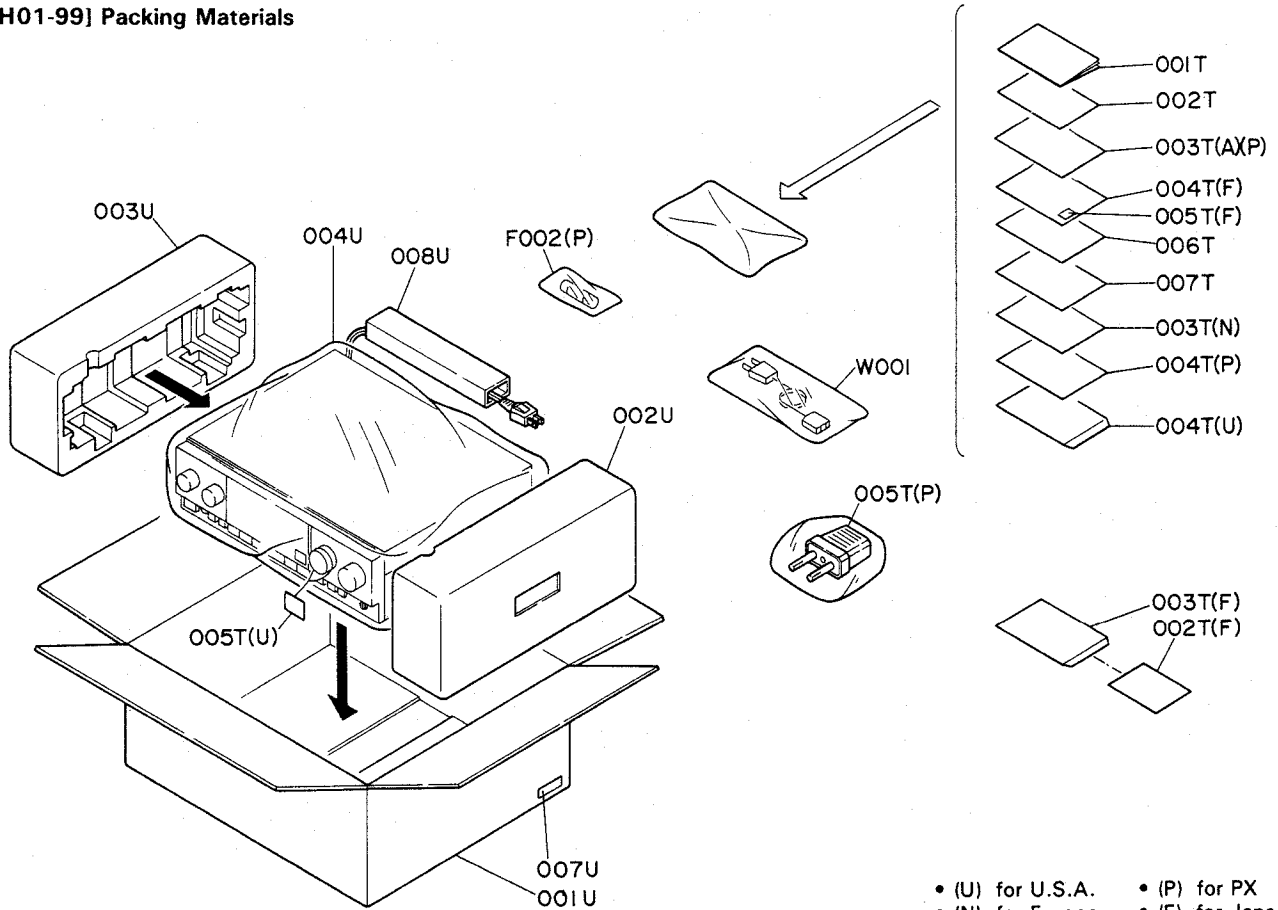

- (U) for U.S.A.
- (N) for Europe
- (A) for Australia
- (P) for PX
- (F) for Japa

REF. DESIG.	Q'TY					PART NO.	DESCRIPTION
	U	N	A	P	F		
001T	1	1	1			263H851310	User Manual
001T					1	263H851110	User Manual
001T	1					263H851210	User Manual
002T	1	1	1			263H851320	User Manual, Spec (PM-64)
002T					1	9631000130	Warranty Card
002T	1					263H851220	User Manual, Spec (PM-64 Only)
002T	1	1				264H851320	User Manual, Spec (PM-54)
002T	1					264H851220	User Manual, Spec (PM-54)
003T			1			9631000090	Warranty Card
003T					1	128T854010	Warranty Card
003T	1					263H856010	Circuit Diagram (PM-64)
003T			1			416H854010	Warranty Card
003T	1					103H854010	Warranty Card
003T	1	1				264H856010	Circuit Diagram (PM-54)
004T					1	9611000050	User's Card
004T					1	3435851210	User Manual Flysheet
004T	1					2225813010	Envelope
005T					1	9540000010	License
005T					1	YJ04000240	Jack Plug
005T	1					9560000100	Hang Tag
006T	1					9650000050	Service Station Card Canada
007T	1					101K854210	Warranty Card Canada

REF. DESIG.	Q'TY					PART NO.	DESCRIPTION
	U	N	A	P	F		
001U		1	1			263H801010	Packing Case (PM-64)
001U					1	263H801020	Packing Case (PM-64)
001U	1					263H801030	Packing Case (PM-64)
001U		1	1			264H801010	Packing Case (PM-54)
001U	1					264H801020	Packing Case (PM-54)
002U	1	1	1	1	1	263H809010	Cushion (R)
003U	1	1	1	1	1	263H809020	Cushion (L)
004U	1	1	1	1	1	9091111030	Polyethy Sheet
007U				4		9526019030	Serial No. Card
007U					4	9526019040	Serial No. Card
007U		4				9526019060	Serial No. Card
007U					4	9562019050	Serial No. Card
007U	4					9562019010	Serial No. Card
008U	1			1	1	2864804010	Sleeve
Δ W001				1		ZC02006030	AC Power Cord
Δ W001		1				ZC01805030	AC Power Cord
F002					1	FS10400600	Fuse 4A

For Service Manuals Contact
MAURITRON TECHNICAL SERVICES
 8 Cherry Tree Rd, Chinnor
 Oxon OX9 4QY
 Tel:- 01844-351694 Fax:- 01844-352554
 Email:- enquiries@mauritron.co.uk

- (U) for U.S.A. • (P) for PX
- (N) for Europe • (F) for Japan
- (A) for Australia

10. ELECTRICAL PARTS LIST

REF. DESIG.	Q'TY					PART NO.	DESCRIPTION
	U	N	A	P	F		
P401	1	1	1	1	1	YK263H1510	P401-PHONO AMP/INPUT JACK CIRCUIT BOARD P.W. Board, Phono Amp/ Input Jack
	1	1	1	1	1	ZZ263H1510	P.W. Board Assembly
P401-CAPACITORS							
C403	1	1	1	1	1	DF35100520	Mica 1000pF ± 5%
C404	1	1	1	1	1	DF35100520	Mica 1000pF ± 5%
C405	1	1	1	1	1	0A22800160	Elect 2200µF 6.3V
C406	1	1	1	1	1	0A22800160	Elect 2200µF 6.3V
C407	1	1	1	1	1	DF55681090	Film 680pF ± 5%
C408	1	1	1	1	1	DF55681090	Film 680pF ± 5%
C409	1	1	1	1	1	DF75473530	Film 0.047µF ± 5%
C410	1	1	1	1	1	DF75473530	Film 0.047µF ± 5%
C411	1	1	1	1	1	DF55332090	Film 3300pF ± 5%
C412	1	1	1	1	1	DF55332090	Film 3300pF ± 5%
C413	1	1	1	1	1	DF75103530	Film 0.01µF ± 5%
C414	1	1	1	1	1	DF75103530	Film 0.01µF ± 5%
C415	1	1	1	1	1	EA10602560	Elect 10µF 25V
C416	1	1	1	1	1	EA10602560	Elect 10µF 25V
C417	1	1	1	1	1	DF15392310	Film 3900pF ± 5%
C418	1	1	1	1	1	DF15392310	Film 3900pF ± 5%
C419	1	1	1	1	1	0A47701630	Elect 470µF 16V
C420	1	1	1	1	1	0A47701630	Elect 470µF 16V
C421	1	1	1	1	1	DK18103310	Ceramic 0.01µF +80% -20%
C422	1	1	1	1	1	DK18103310	Ceramic 0.01µF +80% -20%
P401-RESISTORS (All Resistor are ± 5% & 1/4W)							
R403	1	1	1	1	1	GD05220140	22Ω
R404	1	1	1	1	1	GD05220140	22Ω
R405	1	1	1	1	1	GD05101140	100Ω
R406	1	1	1	1	1	GD05101140	100Ω
R407	1	6	6	6	6	GD05473140	47kΩ
R412	1	1	1	1	1	GD05472140	4.7kΩ
R413	1	1	1	1	1	GD05472140	4.7kΩ
R414	1	1	1	1	1	GD05472140	4.7kΩ
R415	1	1	1	1	1	GD05391140	390Ω
R416	1	1	1	1	1	GD05391140	390Ω
R417	1	1	1	1	1	GD05121140	120Ω
R418	1	1	1	1	1	GD05121140	120Ω
R419	1	1	1	1	1	GD05683140	68kΩ
R420	1	1	1	1	1	GD05683140	68kΩ
R421	1	1	1	1	1	GD05562140	5.6kΩ
R422	1	1	1	1	1	GD05562140	5.6kΩ
R423	1	1	1	1	1	GD05331140	330Ω

REF. DESIG.	Q'TY					PART NO.	DESCRIPTION
	U	N	A	P	F		
R424	1	1	1	1	1	GD05331140	330Ω
R425	1	1	1	1	1	GD05104140	100kΩ
R426	1	1	1	1	1	GD05104140	100kΩ
R427	1	1	1	1	1	GD05120140	12Ω
R428	1	1	1	1	1	GD05120140	12Ω
R429	1	1	1	1	1	GD05121140	120Ω
R430	1	1	1	1	1	GD05121140	120Ω
△ R431	1	1	1	1	1	GG05470140	47Ω
△ R432	1	1	1	1	1	GG05470140	47Ω
R433	1	1	1	1	1	GG05470140	47Ω
?	4	4	4	4	4	GD05561140	560Ω
R436	1	1	1	1	1	GD05561140	560Ω
P401-SEMICONDUCTORS							
Q401	1	4	4	4	4	HF203691B0	F.E.T. 2SK369(BL)
Q404	1	4	4	4	4	HF203691B0	F.E.T. 2SK369(BL)
Q405	1	1	1	1	1	HC10017090	IC NJM 2043 DD
P401-MISCELLANEOUS							
J401	1	1	1	1	1	YT02020290	Terminal Phono
J402	1	1	1	1	1	YT02060180	Terminal Tuner, CD & AUX
J403	1	1	1	1	1	YT02040470	Terminal Tape 1 In/Out
J404	1	1	1	1	1	YJ06002460	Jack (7P)
J405	1	1	1	1	1	YJ06002460	Jack (7P)
J406	1	1	1	1	1	YJ06002430	Jack (3P)
J407	1	1	1	1	1	YJ06002390	Jack (5P)
L401	1	1	1	1	1	LC16820020	Choke Coil 6.8µH
L402	1	1	1	1	1	LC16820020	Choke Coil 6.8µH
S401	1	1	1	1	1	SS08060040	Slide Switch, Selector
S402	1	1	1	1	1	SR00050190	Rotary Switch, Selector Cont
W402	1	1	1	1	1	YU07100260	Jumper Lead
P701-MAIN AMP/POWER SUPPLY CIRCUIT BOARD (PM-64 ONLY)							
P701	1	1	1	1	1	YK263H2410	P.W. Board, Main Amp/ Power Supply
	1					ZZ263H2410	P.W. Board Assembly
			1			ZZ263H8410	P.W. Board Assembly
						ZZ263H7410	P.W. Board Assembly
(PM-54 ONLY)							
P701	1	1	1		1	YK263H2410	P.W. Board Main Amp/ Power Supply
	1					ZZ264H2410	P.W. Board Assembly
			1			ZZ264H8410	P.W. Board Assembly

For Service Manuals Contact
MAURITRON TECHNICAL SERVICES
 8 Cherry Tree Rd, Chinnor
 Oxon OX9 4QY
 Tel: 01844-351694 Fax: 01844-352554
 Email: enquiries@mauritron.co.uk

- (U) for U.S.A.
- (N) for Europe
- (A) for Australia
- (P) for PX
- (F) for Japan

REF. DESIG.	Q'TY					PART NO.	DESCRIPTION	REF. DESIG.	Q'TY					PART NO.	DESCRIPTION		
	U	N	A	P	F				U	N	A	P	F				
P701-CAPACITORS							CN01	1	1	1	1	1	EA47505030	Elect	4.7 μ F 50V		
C701	1	1	1	1	1	OA10605010	Elect	10 μ F	50V	CN02	1	1	1	1	EA47405030	Elect	0.47 μ F 50V
C702	1	1	1	1	1	OA10605010	Elect	10 μ F	50V	CN03	1	1	1	1	EA22601630	Elect	22 μ F 16V
C703	1	1	1	1	1	DF55221520	Film	220pF	\pm 5%	CN04	1	1	1	1	EA47601010	Elect	47 μ F 10
C704	1	1	1	1	1	DF55221520	Film	220pF	\pm 5%	CN05	1	1	1	1	EA10505030	Elect	1 μ F 50V
C707	1	1	1	1	1	DF31100520	Mica	10pF	\pm 0.5pF	CN06	1	1	1	1	EA10505030	Elect	1 μ F 50V
C708	1	1	1	1	1	DF31100520	Mica	10pF	\pm 0.5pF	CU01	1	1	1	1	DF15681550	Film	680pF \pm 5%
C709	1	1	1	1	1	DF54471090	Film	470pF	\pm 5%	CU02	1	1	1	1	DF15681550	Film	680pF \pm 5%
C710	1	1	1	1	1	DF54471090	Film	470pF	\pm 5%	CU05	1	1	1	1	DF15151550	Film	150pF \pm 5%
C713	1	1	1	1	1	OA10701610	Elect	100 μ F	16V	CU06	1	1	1	1	DF15151550	Film	150pF \pm 5%
C714	1	1	1	1	1	OA10701610	Elect	100 μ F	16V	CW01	1	1	1	1	DF16103350	Film	0.01 μ F \pm 10%
C715	4	4	4	4	4	DF15101550	Film	100pF	100V	CW02	1	1	1	1	DF16103350	Film	0.01 μ F \pm 10%
C718	1	1	1	1	1	DF15104350	Film	0.1 μ F	\pm 5%	P701-RESISTORS							
C721	1	1	1	1	1	DF15104350	Film	0.1 μ F	\pm 5%	(All Resistor are \pm5% & 1/4W)							
C722	1	1	1	1	1	DF15104350	Film	0.1 μ F	\pm 5%	R701	1	1	1	1	GD05102140	1k Ω	
C723	1	1	1	1	1	DF15104350	Film	0.1 μ F	\pm 5%	R702	1	1	1	1	GD05102140	1k Ω	
C724	1	1	1	1	1	DF15104350	Film	0.1 μ F	\pm 5%	R705	1	1	1	1	GD05823140	82k Ω	
C725	1	1	1	1	1	EA47610030	Elect	47 μ F	100V	R706	1	1	1	1	GD05823140	82k Ω	
C726	1	1	1	1	1	EA47610030	Elect	47 μ F	100V	R715	1	1	1	1	GD05331140	330 Ω	
C727	1	1	1	1	1	OA22701610	Elect	220 μ F	16V	R716	1	1	1	1	GD05331140	330 Ω	
C728	1	1	1	1	1	OA22701610	Elect	220 μ F	16V	R719	1	1	1	1	GD05823140	82k Ω	
C801	1	1	1	1	1	EB10908010	Elect	10000 μ F	80V (PM-64)	R720	1	1	1	1	GD05823140	82k Ω	
C801	1	1	1	1	1	EB10906330	Elect	10000 μ F	63V (PM-54)	R725	1	1	1	1	GD05471140	470 Ω	
C802	1	1	1	1	1	EB10908010	Elect	10000 μ F	80V (PM-64)	R726	1	1	1	1	GD05471140	470 Ω	
C802	1	1	1	1	1	EB10906330	Elect	10000 μ F	63V (PM-54)	R727	1	1	1	1	GD05681140	680 Ω	
C803	1	1	1	1	1	EB68805520	Elect	6800 μ F	55V (PM-64)	R728	1	1	1	1	GD05681140	680 Ω	
C803	1	1	1	1	1	EB68804540	Elect	6800 μ F	45V (PM-54)	R729	1	1	1	1	GD05222140	2.2k Ω	
C804	1	1	1	1	1	EB68805520	Elect	6800 μ F	55V (PM-64)	R730	1	1	1	1	GD05222140	2.2k Ω	
C804	1	1	1	1	1	EB68804540	Elect	6800 μ F	45V (PM-54)	R731	1	1	1	1	RA01020600	Trimming 1k Ω	
C805	1	1	1	1	1	EA10708050	Elect	100 μ F	80V	R732	1	1	1	1	RA01020600	Trimming 1k Ω	
C806	1	1	1	1	1	EA10708050	Elect	100 μ F	80V	R733	4	4	4	4	GD05101140	100 Ω	
C807	1	1	1	1	1	EA10505030	Elect	1 μ F	50V	R736	1	1	1	1	GG05471140	470 Ω	
C811	1	1	1	1	1	EA10706330	Elect	100 μ F	63V	R737	1	1	1	1	GG05471140	470 Ω	
C813	1	1	1	1	1	OA22703510	Elect	220 μ F	35V	R738	1	1	1	1	GG05471140	470 Ω	
C814	1	1	1	1	1	OA22703510	Elect	220 μ F	35V	R739	1	1	1	1	GG05151120	150 Ω 1/2W	
C815	1	1	1	1	1	OA10701610	Elect	100 μ F	16V	R740	1	1	1	1	GG05151120	150 Ω 1/2W	
C816	1	1	1	1	1	OA10701610	Elect	100 μ F	16V	R741	1	1	1	1	GG05100140	10 Ω	
C817	1	1	1	1	1	OA47701630	Elect	470 μ F	16V	R742	1	1	1	1	GG05100140	10 Ω	
C818	1	1	1	1	1	OA47701630	Elect	470 μ F	16V	R743	1	1	1	1	GG05100140	10 Ω	
C819	1	1	1	1	1	DK18103560	Ceramic	0.01 μ F	+80% -20%	R744	1	1	1	1	GG05100140	10 Ω	
C820	1	1	1	1	1	DK18103560	Ceramic	0.01 μ F	+80% -20%	R745	1	1	1	1	BW10000060	Compo. 0.22 Ω \times 2 5W	
										R746	1	1	1	1	BW10000060	Compo. 0.22 Ω \times 2 5W	
										R747	1	1	1	1	NK05022020	2.2 Ω 2W	
										R748	1	1	1	1	NK05022020	2.2 Ω 2W	
										R749	1	1	1	1	NK05100020	10 Ω 2W	
										R750	1	1	1	1	NK05100020	10 Ω 2W	
										R751	1	1	1	1	GA05331010	330 Ω 1W	
										R752	1	1	1	1	GA05331010	330 Ω 1W	

M9647

- (U) for U.S.A.
- (N) for Europe
- (A) for Australia
- (P) for PX
- (F) for Japa

REF. DESIG.	Q'TY					PART NO.	DESCRIPTION
	U	N	A	P	F		
△ R801	1	1	1	1	1	NK05101010	100Ω 1W
△ R802	1	1	1	1	1	NK05101010	100Ω 1W
R804	1	1	1	1	1	GD05103140	10kΩ
△ R805	1	1	1	1	1	NK05681010	680Ω 1W
△ R806	1	1	1	1	1	NK05681010	680Ω 1W
R807	1	1	1	1	1	NK05123010	12kΩ 1W
R808	1	1	1	1	1	NK05123010	12kΩ 1W
R809	1	1	1	1	1	GG05102120	1kΩ 1/2W
R810	1	1	1	1	1	GG05102120	1kΩ 1/2W
R811	1	1	1	1	1	GA05681020	680Ω 2W
R812	1	1	1	1	1	GG05181120	180Ω 1/2W
R813	1	1	1	1	1	GG05392120	3.9kΩ 1/2W
R814	1	1	1	1	1	GG05392120	3.9kΩ 1/2W
RN01	?	8	8	8	8	GD05102140	1kΩ
RN08							
RN09	?	4	4	4	4	GD05183140	18kΩ
RN12							
RN13	?	4	4	4	4	GD05333140	33kΩ
RN16							
RN17	1	1	1	1	1	GD05152140	1.5kΩ
RN18	1	1	1	1	1	GD05563140	56kΩ
RN19	1	1	1	1	1	GD05683140	68kΩ
RN20	1	1	1	1	1	GD05152140	1.5kΩ
RN21	1	1	1	1	1	GD05683140	68kΩ
RN22	1	1	1	1	1	GD05683140	68kΩ
RN23	1	1	1	1	1	GD05333140	33kΩ
RN24	1	1	1	1	1	GD05274040	270kΩ
RN25	1	1	1	1	1	GD05333140	33kΩ
RN26	1	1	1	1	1	GD05563140	56kΩ
RN27	1	1	1	1	1	GD05333140	33kΩ
RN28	1	1	1	1	1	GD05223140	22kΩ
RN29	1	1	1	1	1	GD05104040	100kΩ
RN30	1	1	1	1	1	GD05473140	47kΩ
RN31	1	1	1	1	1	GD05124040	120kΩ
RU01	?	4	4	4	4	GD05103140	10kΩ
RU04							
RU05	1	1	1	1	1	GD05222140	2.2kΩ (PM-64)
RU05	1	1	1	1	1	GD05332140	3.3kΩ (PM-54)
RU06	1	1	1	1	1	GD05222140	2.2kΩ (PM-64)
RU06	1	1	1	1	1	GD05332140	3.3kΩ (PM-54)
RU07	1	1	1	1	1	GD05393140	39kΩ
RU08	1	1	1	1	1	GD05393140	39kΩ
RU25	1	1	1	1	1	GG05222120	2.2kΩ 1/2W
RU26	1	1	1	1	1	GG05222120	2.2kΩ 1/2W
RW03	1	1	1	1	1	GA05152010	1.5kΩ 1W (PM-64)
RW03	1	1	1	1	1	GG05331120	330Ω 1/2W (PM-54)
RW04	1	1	1	1	1	GA05152010	1.5kΩ 1W (PM-64)
RW04	1	1	1	1	1	GG05331120	330Ω 1/2W (PM-54)
RW05	1	1	1	1	1	NK05182010	1.8kΩ 1W (PM-64)
RW05	1	1	1	1	1	GG05681120	680Ω 1/2W (PM-54)

REF. DESIG.	Q'TY					PART NO.	DESCRIPTION
	U	N	A	P	F		
							P701-SEMICONDUCTORS
D705							
?	4	4	4	4	4	HD20003210	Diode 1S2471
D708							
D709							
?	4	4	4	4	4	HD30064060	Zener RD6.2E
D712							
△ D801	1	1	1	1	1	HE20013290	Diode D5FB20 (PM-64)
△ D801	1	1	1		1	HE20009290	Diode S5VB20 (PM-54)
△ D802	1	1	1	1	1	HD20008290	Diode S4VB20
△ D803	1	1	1	1	1	HD20003210	Diode 1S2471
△ D805	1	1	1	1	1	HD20022030	Diode DSF10C
D807	1	1	1	1	1	HD30051060	Zener RD16E
D808	1	1	1	1	1	HD30051060	Zener RD16E
D809	1	1	1	1	1	HD20001000	Diode 1S1555
D810	1	1	1	1	1	HD20001000	Diode 1S1555
DN01							
?	4	4	4	4	4	HD20003210	Diode 1S2471
DN04							
DU01							
?	4	4	4	4	4	HD20003210	Diode 1S2471
DU04							
DU07	1	1	1	1	1	HD20011290	Diode S3V20
DU08	1	1	1	1	1	HD20011290	Diode S3V20
DU09	1	1	1	1	1	HD20022030	Diode DSF10C
DU10	1	1	1	1	1	HD20022030	Diode DSF10C
DU11	1	1	1	1	1	HD20003210	Diode 1S2471
DU12	1	1	1	1	1	HD20003210	Diode 1S2471
DW01	1	1	1	1	1	HD20003210	Diode 1S2471
DW02	1	1	1	1	1	HD20003210	Diode 1S2471
DW03	1	1	1	1	1	HD20003210	Diode 1S2471
Q705	1	1	1	1	1	HC10145030	IC STK3102-2A
Q707	1	1	1	1	1	HT318452B0	Transistor 2SC1845 (F, E)
Q708	1	1	1	1	1	HT318452B0	Transistor 2SC1845 (F, E)
Q709	1	1	1	1	1	HT326821P0	Transistor 2SC2682(P) (PM-64)
Q710	1	1	1	1	1	HT326821P0	Transistor 2SC2682(P) (PM-64)
Q711	1	1	1	1	1	HT111421P0	Transistor 2SA1142(P) (PM-64)
Q712	1	1	1	1	1	HT111421P0	Transistor 2SA1142(P) (PM-64)
Q713	1	1	1	1	1	HT332982D0	Transistor 2SC3298 (O, Y)

For Service Manuals Contact
MAURITRON TECHNICAL SERVICES
 8 Cherry Tree Rd, Chinnor
 Oxon OX9 4QY
 Tel:- 01844-351694 Fax:- 01844-352554
 Email:- enquiries@mauritron.co.uk

- (U) for U.S.A. • (P) for PX
- (N) for Europe • (F) for Japan
- (A) for Australia

REF. DESIG.	Q'TY					PART NO.	DESCRIPTION	REF. DESIG.	Q'TY					PART NO.	DESCRIPTION
	U	N	A	P	F				U	N	A	P	F		
Q714	1	1	1	1	1	HT332982D0	Transistor 2SC3298 (O, Y)	J701	1	1	1	1	1	YJ06002430	Jack (3P)
Q715	1	1	1	1	1	HT113062D0	Transistor 2SA1306 (O, Y)	J801	1	1	1	1	1	YJ06002430	Jack (3P)
Q716	1	1	1	1	1	HT113062D0	Transistor 2SA1306 (O, Y)	J802	1	1	1	1	1	YJ06002430	Jack (3P)
Q717	1	1	1	1	1	HT327742B0	Transistor 2SC2774 (O, Y)	J805	1	1	1	1	1	YJ06001050	Jack (5P)
							(PM-64)	J811	1	1	1	1	1	YJ08000270	Jack
Q717	1	1	1	1	1	HT327732B0	Transistor 2SC2773 (O, Y)	J811	1	1	1	1	1	YJ08000170	Jack
							(PM-54)	J812	1	1	1	1	1	YJ08000270	Jack
Q718	1	1	1	1	1	HT327742B0	Transistor 2SC2774 (O, Y)	J812	1	1	1	1	1	YJ08000170	Jack
							(PM-64)	J813	1	1	1	1	1	YJ08000270	Jack
Q718	1	1	1	1	1	HT327732B0	Transistor 2SC2773 (O, Y)	J813	1	1	1	1	1	YJ08000170	Jack
							(PM-54)	J814	1	1	1	1	1	YJ08000270	Jack
								J814	1	1	1	1	1	YJ08000170	Jack
Q719	1	1	1	1	1	HT111702B0	Transistor 2SA1170 (O, Y)	JW01	1	1	1	1	1	YT03080010	Terminal Speaker 1/2
							(PM-64)	JW02	1	1	1	1	1	YJ06002430	Jack (3P)
Q719	1	1	1	1	1	HT111692B0	Transistor 2SA1169 (O, Y)								
							(PM-54)	L701	1	1	1	1	1	LL23905120	Coil
Q720	1	1	1	1	1	HT111702B0	Transistor 2SA1170 (O, Y)	L702	1	1	1	1	1	LL23905120	Coil
							(PM-64)	LW01	1	1	1	1	1	LY20240190	Relay (PM-64)
Q720	1	1	1	1	1	HT111692B0	Transistor 2SA1169 (O, Y)	LW01	1	1	1	1	1	LY20240260	Relay (PM-54)
							(PM-54)	LW02	1	1	1	1	1	LY20240190	Relay (PM-64)
△ Q801	1	1	1	1	1	HT412662B0	Transistor 2SD1266 (Q, P)	LW02	1	1	1	1	1	LY20240260	Relay (PM-54)
△ Q802	1	1	1	1	1	HT209412B0	Transistor 2SB941 (Q, P)	LW03	1	1	1	1	1	LY20240240	Relay
QN01	1	1	1	1	1	HT318452B0	Transistor 2SC1845 (F, E)								
QN02	1	1	1	1	1	HT318452B0	Transistor 2SC1845 (F, E)								
QN03	1	1	1	1	1	HT109922B0	Transistor 2SA992 (F, E)								
QN04	1	1	1	1	1	HT109922B0	Transistor 2SA992 (F, E)								
QN05	1	1	1	1	1	HT109922B0	Transistor 2SA992 (F, E)								
QN06	1	1	1	1	1	HT318452B0	Transistor 2SC1845 (F, E)								
QN07	1	1	1	1	1	HC10042050	IC TA7317P								
QN08	1	1	1	1	1	HP00009230	Varistor PTH487								
△ QU03	1	1	1	1	1	HT335193A0	Transistor 2SC3519 (O, P, Y) (PM-64)								
△ QU03	1	1	1	1	1	HT412382B0	Transistor 2SD1238 (R, S) (PM-54)	△ C851	1	1	1	1	1	DK18103840	Ceramic 0.01μF +80% -20%
△ QU04	1	1	1	1	1	HT113863A0	Transistor 2SA1386 (O, P, Y) (PM-64)	△ C851						DK18103850	Ceramic 0.01μF +80% -20%
△ QU04	1	1	1	1	1	HT209222B0	Transistor 2SB922 (R, S) (PM-54)								
								△ S851	1	1	1	1	1	SP01010820	P851-MISCELLANEOUS Push Switch Power
QU05	1	1	1	1	1	HT323441D0	Transistor 2SC2344(D)								
QU06	1	1	1	1	1	HT110111D0	Transistor 2SA1011(D)								
QU07	1	1	1	1	1	HT318452B0	Transistor 2SC1845 (F, E)								
QU08	1	1	1	1	1	HT109922B0	Transistor 2SA992 (F, E)								
							P701-MISCELLANEOUS (PM-64 ONLY)								
△ F801	1					FS10500500	Fuse 5A								
△ F801		1	1			FS10500800	Fuse 5A	CE01	1	1	1	1	1	OA47505010	Elect 4.7μF 50V
△ F801				1	1	FS10600600	Fuse 6A	CE02	1	1	1	1	1	OA47505010	Elect 4.7μF 50V
△ F802	1					FS10500500	Fuse 5A	CE03	1	1	1	1	1	EA22701030	Elect 220μF 10V
△ F802		1	1			FS10500800	Fuse 5A	CE04	1	1	1	1	1	EA22701030	Elect 220μF 10V
△ F802				1	1	FS10500800	Fuse 5A	CE05	1	1	1	1	1	DF15152310	Film 1500pF ± 5%
△ F802					1	FS10600600	Fuse 6A	CE06	1	1	1	1	1	DF15152310	Film 1500pF ± 5%
								CE07	1	1	1	1	1	DF15103310	Film 0.01μF ± 5%
							(PM-54 ONLY)	CE08	1	1	1	1	1	DF15103310	Film 0.01μF ± 5%
△ F801	1					FS10500500	Fuse 5A	CE09	1	1	1	1	1	DF15332310	Film 3300pF ± 5%
△ F801		1	1			FS10400800	Fuse 4A	CE10	1	1	1	1	1	DF15332310	Film 3300pF ± 5%
△ F801				1		FS10500600	Fuse 5A								
△ F802	1					FS10500500	Fuse 5A								
△ F802		1	1			FS10400800	Fuse 4A								
△ F802				1		FS10500600	Fuse 5A								

For Service Manuals Contact
MAURITRON TECHNICAL SERVICES
 8 Cherry Tree Rd, Chinnor
 Oxon OX9 4QY
 Tel: 01844-351694 Fax: 01844-352554
 Email: enquiries@mauritron.co.uk

- (U) for U.S.A.
- (N) for Europe
- (A) for Australia
- (P) for PX
- (F) for Japan

REF. DESIG.	Q'TY					PART NO.	DESCRIPTION
	U	N	A	P	F		
CE11	1	1	1	1	1	DF15473310	Film 0.047µF ± 5%
CE12	1	1	1	1	1	DF15473310	Film 0.047µF ± 5%
CE13	1	1	1	1	1	EA47505030	Elect 4.7µF 50V
CE14	1	1	1	1	1	EA47505030	Elect 4.7µF 50V
CE15	1	1	1	1	1	DF15103310	Film 0.01µF ± 5%
CE16	1	1	1	1	1	DF15103310	Film 0.01µF ± 5%
CE17	1	1	1	1	1	DF55151520	Film 150pF ± 5%
CE18	1	1	1	1	1	DF55151520	Film 150pF ± 5%
CE19	1	1	1	1	1	EA47505030	Elect 4.7µF 50V
CE20	1	1	1	1	1	EA47505030	Elect 4.7µF 50V
CE51	1	1	1	1	1	DF15153310	Film 0.015µF ± 5% (PM-64)
CE52	1	1	1	1	1	DF15153310	Film 0.015µF ± 5% (PM-64)
PE01-RESISTORS (All Resistor are ± 5% & 1/4W)							
RE01	1	1	1	1	1	GD05683140	68kΩ
RE02	1	1	1	1	1	GD05683140	68kΩ
RE03	1	1	1	1	1	GD05224140	220kΩ
RE04	1	1	1	1	1	GD05224140	220kΩ
RE05	1	1	1	1	1	GD05222140	2.2kΩ
RE06	1	1	1	1	1	GD05222140	2.2kΩ
RE07	1	1	1	1	1	GD05221140	220Ω
RE08	1	1	1	1	1	GD05221140	220Ω
RE09	1	1	1	1	1	GD05472140	4.7kΩ
RE10	1	1	1	1	1	GD05472140	4.7kΩ
RE11	1	1	1	1	1	GD05221140	220Ω
RE12	1	1	1	1	1	GD05221140	220Ω
RE13	1	1	1	1	1	RM01040810	Variable 100kΩ × 2
RE14	1	1	1	1	1	RM01040810	Variable 100kΩ × 2
RE15	1	1	1	1	1	GD05153140	15kΩ
RE16	1	1	1	1	1	GD05153140	15kΩ
RE17	1	1	1	1	1	GD05182140	1.8kΩ
RE18	1	1	1	1	1	GD05182140	1.8kΩ
RE19	1	1	1	1	1	GD05103140	10kΩ
RE20	1	1	1	1	1	GD05103140	10kΩ
RE21	1	1	1	1	1	GD05821140	820Ω
RE22	1	1	1	1	1	GD05821140	820Ω
RE23	1	1	1	1	1	GD05333140	33kΩ
RE24	1	1	1	1	1	GD05333140	33kΩ
RE25	1	1	1	1	1	GD05183140	18kΩ
RE26	1	1	1	1	1	GD05183140	18kΩ
RE27	1	1	1	1	1	GD05682140	6.8kΩ
RE28	1	1	1	1	1	GD05682140	6.8kΩ
RE29	1	1	1	1	1	GD05272140	2.7kΩ
RE30	1	1	1	1	1	GD05272140	2.7kΩ
RE51	1	1	1	1	1	GD05225140	2.2MΩ (PM-64)
RE52	1	1	1	1	1	GD05225140	2.2MΩ (PM-64)
QE01	1	1	1	1	1	HC10026090	PE01-SEMICONDUCTOR IC NJM2041D

REF. DESIG.	Q'TY					PART NO.	DESCRIPTION
	U	N	A	P	F		
JE51	1	1	1	1	1	YJ06002430	PE01-MISCELLANEOUS Jack (3P)
SE51	1	1	1	1	1	SP02011180	Push Switch Speaker System 1
SE52	1	1	1	1	1	SP02011210	Push Switch Speaker System 2
SE53	1	1	1	1	1	SP02020770	Push Switch Direct & Sub-sonic (PM-64)
SE53	1	1	1	1	1	SP02011180	Push Switch Direct (PM-54)
WE01	1	1	1	1	1	YU03140260	Jumpr Lead
WE02	1	1	1	1	1	YU03100260	Jumpr Lead
WE03	1	1	1	1	1	YU03340260	Jumpr Lead
WE51	1	1	1	1	1	YU03120260	Jumpr Lead (PM-64)
WE53	1	1	1	1	1	YU03200260	Jumpr Lead (PM-64)
PT01-VOL/BALANCE CIRCUIT BOARD							
PT01	1	1	1	1	1	YK263H1530	P.W. Board, Vol/Balance
	1	1	1	1	1	ZZ263H1530	P.W. Board Assembly (PM-64)
	1	1	1	1	1	ZZ264H1530	P.W. Board Assembly (PM-54)
PT01-CAPACITORS							
CT01	1	1	1	1	1	DF55471090	Film 470pF ± 5%
CT02	1	1	1	1	1	DF55471090	Film 470pF ± 5%
CT03	1	1	1	1	1	DF15473310	Film 0.047µF ± 5%
CT04	1	1	1	1	1	DF15473310	Film 0.047µF ± 5%
PT01-RESISTORS (All Resistor are ± 5% & 1/4W)							
RT01	4	4	4	4	4	GD05222140	2.2kΩ
RT04							
RT05	1	1	1	1	1	GD05393140	39kΩ
RT06	1	1	1	1	1	GD05393140	39kΩ
RT07	1	1	1	1	1	GD05103140	10kΩ
RT08	1	1	1	1	1	GD05103140	10kΩ
RT51	1	1	1	1	1	RM01040820	Variable 100kΩ × 2 Vol.
RT52	1	1	1	1	1	RK02540050	Variable 250kΩ Balance
PT01-MISCELLANEOUS							
ST01	1	1	1	1	1	SP04020430	Push Switch Tape 1/2 Mon
ST02	1	1	1	1	1	SP02030320	Push Switch Copy/Loudness/Mono (PM-64)
ST02	1	1	1	1	1	SP02011210	Push Switch Copy 1-2 (PM-54)
ST03	1	1	1	1	1	SP02011180	Push Switch Loudness (PM-54)
WT01	1	1	1	1	1	YU04140260	Jumper Lead (4P)
WT02	1	1	1	1	1	YU04140260	Jumper Lead (4P)

For Service Manuals Contact
MAURITRON TECHNICAL SERVICES
 8 Cherry Tree Rd, Chinnor
 Oxon OX9 4QY
 Tel: 01844-351694 Fax: 01844-352554
 Email: enquiries@mauritron.co.uk

Mabso

- (U) for U.S.A.
- (N) for Europe
- (A) for Australia
- (P) for PX
- (F) for Japan

REF. DESIG.	Q'TY					PART NO.	DESCRIPTION
	U	N	A	P	F		
PU51	1	1	1	1	1	YK263H2430 ZZ263H2430	PU51-COMP-MULTI CIRCUIT BOARD P.W. Board, Comp-Multi P.W. Board Assembly
CU51	1	1	1	1	1	EA10601630	PU51-CAPACITORS Elect 10 μ F 16V
CU52	1	1	1	1	1	DD15220370	Ceramic 22pF \pm 5%
CU53	1	1	1	1	1	DF15103310	Film 0.01 μ F \pm 5%
CU54	1	1	1	1	1	EA10602530	Elect 10 μ F 25V
RU51	1	1	1	1	1	GG05101140	PU51-RESISTORS (All Resistor are \pm 5% & 1/4W) 100 Ω
RU52	1	1	1	1	1	GG05101140	100 Ω
RU53	1	1	1	1	1	GD05104140	100k Ω
RU54	1	1	1	1	1	GD05104140	100k Ω
RU55	1	1	1	1	1	GD05473140	47k Ω
RU56	1	1	1	1	1	GD05152140	1.5k Ω
RU57	1	1	1	1	1	GD05222140	2.2k Ω
RU58	1	1	1	1	1	GG05152140	1.5k Ω
RU59	1	1	1	1	1	GG05102140	1k Ω
RU60	1	1	1	1	1	GG05152140	1.5k Ω
RU61	1	1	1	1	1	GD05392140	3.9k Ω
RU62	1	1	1	1	1	GD05392140	3.9k Ω
RU63	1	1	1	1	1	GD05122140	1.2k Ω
RU64	1	1	1	1	1	GD05122140	1.2k Ω
RU65	1	1	1	1	1	GD05104140	100k Ω
RU66	1	1	1	1	1	GD05104140	100k Ω
RU67	1	1	1	1	1	GG05152120	1.5k Ω 1/2W
DU51	1	1	1	1	1	HD20002210	PU51-SEMICONDUCTORS Diode 1S2472
QU51	1	1	1	1	1	HC10022090	IC NJM2903D
QU52	1	1	1	1	1	HC712200A0	IC HD74LS122P
QU53	1	1	1	1	1	HT318452B0	Transistor 2SC1845 (F, E)
QU54	1	1	1	1	1	HT109922B0	Transistor 2SA992 (F, E)
JP51	1	1	1	1	1	YP06003240	PU51-MISCELLANEOUS Plug (12P)
PV01	1	1	1	1	1	YK263H1540 ZZ263H1540	PV01-TAPE 2 IN/OUT JACK CIRCUIT BOARD P.W. Board, Tape 2 In/Out Jack P.W. Board Assembly
JV01	1	1	1	1	1	YT02040490	PV01-MISCELLANEOUS Terminal Tape 2 In/Out

REF. DESIG.	Q'TY					PART NO.	DESCRIPTION
	U	N	A	P	F		
PW51	1	1	1	1	1	YK263H2440 ZZ263H2440	PW51-PHONES CIRCUIT BOARD P.W. Board, Phones P.W. Board Assembly
JW51	1	1	1	1	1	YJ01001790	PW51-MISCELLANEOUS Jack, Phones
JW51					1	YJ01002080	Jack, Phones
WW51	1	1	1	1	1	YU03260260	Jumper Lead
PY01	1	1	1	1	1	YK263H1550 ZZ263H1550	PY01-INDICATOR CIRCUIT BOARD P.W. Board, Indicator P.W. Board Assembly
RY01	1	1	1	1	1	GG05272120	PY01-RESISTORS (All Resistor are \pm 5%) 2.7k Ω 1/2W
RY02	1	1	1	1	1	GG05272120	2.7k Ω 1/2W
DY01							PY01-SEMICONDUCTORS
DY06	6	6	6	6	6	HI10028320	L.E.D. GL-9HD4
VY01	1	1	1	1	1	IN10080610	PY01-MISCELLANEOUS Lamp
WY01	1	1	1	1	1	YU04220260	Jumper Lead
WY02	1	1	1	1	1	YU03140260	Jumper Lead
WY03	1	1	1	1	1	YU05180260	Jumper Lead

For Service Manuals Contact
MAURITRON TECHNICAL SERVICES
8 Cherry Tree Rd, Chinnor
Oxon OX9 4QY
Tel:- 01844-351694 Fax:- 01844-352554
Email:- enquiries@mauritron.co.uk

(W01-99)

Assembly and Wiring

(T01-99)

Adjustment

(X01-00)

Correction

NOTE ON SAFETY:

Symbol Δ Fire or electrical shock hazard. Only original parts should be used to replace any part marked with symbol Δ . Any other component substitution (other than original type), may increase risk of fire or electrical shock hazard.

11. TECHNICAL SPECIFICATIONS

PM-64

AUDIO SECTION

POWER OUTPUT PER CHANNEL

DIN 4 OHMS	110 W
RMS 4 OHMS (20 ~ 20 kHz, 0.06%)	100 W
DIN 8 OHMS (1 kHz, 1%)	110 W
RMS 8 OHMS (20 ~ 20 kHz, 0.03%)	100 W
TOTAL HARMONIC DISTORTION AT RMS 8 OHMS (20 ~ 20 kHz)	0.03%
I.M. DISTORTION	0.03%
DAMPING FACTOR 8 OHMS (1 kHz)	100

MM CARTRIDGE INPUT

Frequency Response (RIAA)(20 ~ 20 kHz)	±0.5 dB
Signal-to-Noise Ratio "IHF A"	80 dB
Input Impedance	47k ohms
Input Capacitance	120 pF
Input Sensitivity	2.5 mV
Equivalent Input Noise	1.0 µV
Dynamic Range	35.5 dB

MC CARTRIDGE INPUT

Input Sensitivity	250 µV
Input Impedance	100 ohms

AUX. INPUT

Input Impedance	27 k ohms
Input Sensitivity	150 mV
Frequency Response	10 Hz ~ 30 kHz
Signal-to-Noise Ratio (IHF A)	90 dB

OUTPUT VOLTAGE

Tape Out [PHONO 1 kHz 7.75 mV Input]	435 mV
--	--------

OUTPUT IMPEDANCE

Tape Out	(Other) 560/800 ohms (PHONO)
----------------	------------------------------

GENERAL

Power Requirements	110/120/220/240 V AC, 50/60 Hz
Power Consumption at Rated Output, both Channels Operating	460 W
Dimensions (W × H × D)	416 × 117 × 334 mm
Weight	10 kg

Specifications and appearance are subject to change for modification without notice.

For Service Manuals Contact
MAURITRON TECHNICAL SERVICES
8 Cherry Tree Rd, Chinnor
Oxon OX9 4QY
Tel:- 01844-351694 Fax:- 01844-352554
Email:- enquiries@mauritron.co.uk

PM-54

AUDIO SECTION

POWER OUTPUT PER CHANNEL

DIN 4 OHMS	70 W
RMS 4 OHMS (20 ~ 20 kHz, 0.06%)	60 W
DIN 8 OHMS (1 kHz, 1%)	70 W
RMS 8 OHMS (20 ~ 20 kHz, 0.03%)	60 W
TOTAL HARMONIC DISTORTION AT RMS 8 OHMS (20 ~ 20 kHz)	0.03%
I.M. DISTORTION	0.03%
DAMPING FACTOR 8 OHMS (1 kHz)	100

MM CARTRIDGE INPUT

Frequency Response (RIAA)(20 ~ 20 kHz)	±0.5 dB
Signal-to-Noise Ratio "IHF A"	80 dB
Input Impedance	47k ohms
Input Capacitance	120 pF
Input Sensitivity	2.5 mV
Equivalent Input Noise	1.0 µV
Dynamic Range	35.5 dB

MC CARTRIDGE INPUT

Input Sensitivity	250 µV
Input Impedance	100 ohms

AUX. INPUT

Input Impedance	27 k ohms
Input Sensitivity	150 mV
Frequency Response	10 Hz ~ 30 kHz
Signal-to-Noise Ratio (IHF A)	90 dB

OUTPUT VOLTAGE

Tape Out [PHONO 1 kHz 7.75 mV Input]	435 mV
--	--------

OUTPUT IMPEDANCE

Tape Out	(Other) 560/800 ohms (PHONO)
----------------	------------------------------

GENERAL

Power Requirements	110/120/220/240 V AC, 50/60 Hz
Power Consumption at Rated Output, both Channels Operating	280 W
Dimensions (W × H × D)	416 × 117 × 334 mm
Weight	8.8 kg

Specifications and appearance are subject to change for modification without notice.

For Service Manuals Contact
MAURITRON TECHNICAL SERVICES
8 Cherry Tree Rd, Chinnor
Oxon OX9 4QY
Tel:- 01844-351694 Fax:- 01844-352554
Email:- enquiries@mauritron.co.uk

12. SCHEMATIC DIAGRAM

Q401-Q404 HF203691B0 25K369(BL)	Q405 HC10017090 NJM2043DD	Q707, Q708 QN01, QN02, QN06, QU07, QU53 HT318452B0 25C1845 (F, E)	Q705 HC10145030 STK3102 II	Q709, Q710 HT326821P0 25C2682(P)	Q711, Q712 HT111421P0 25A1142(P)	Q713, Q714 HT332 25C32
---------------------------------------	---------------------------------	--	----------------------------------	--	--	------------------------------

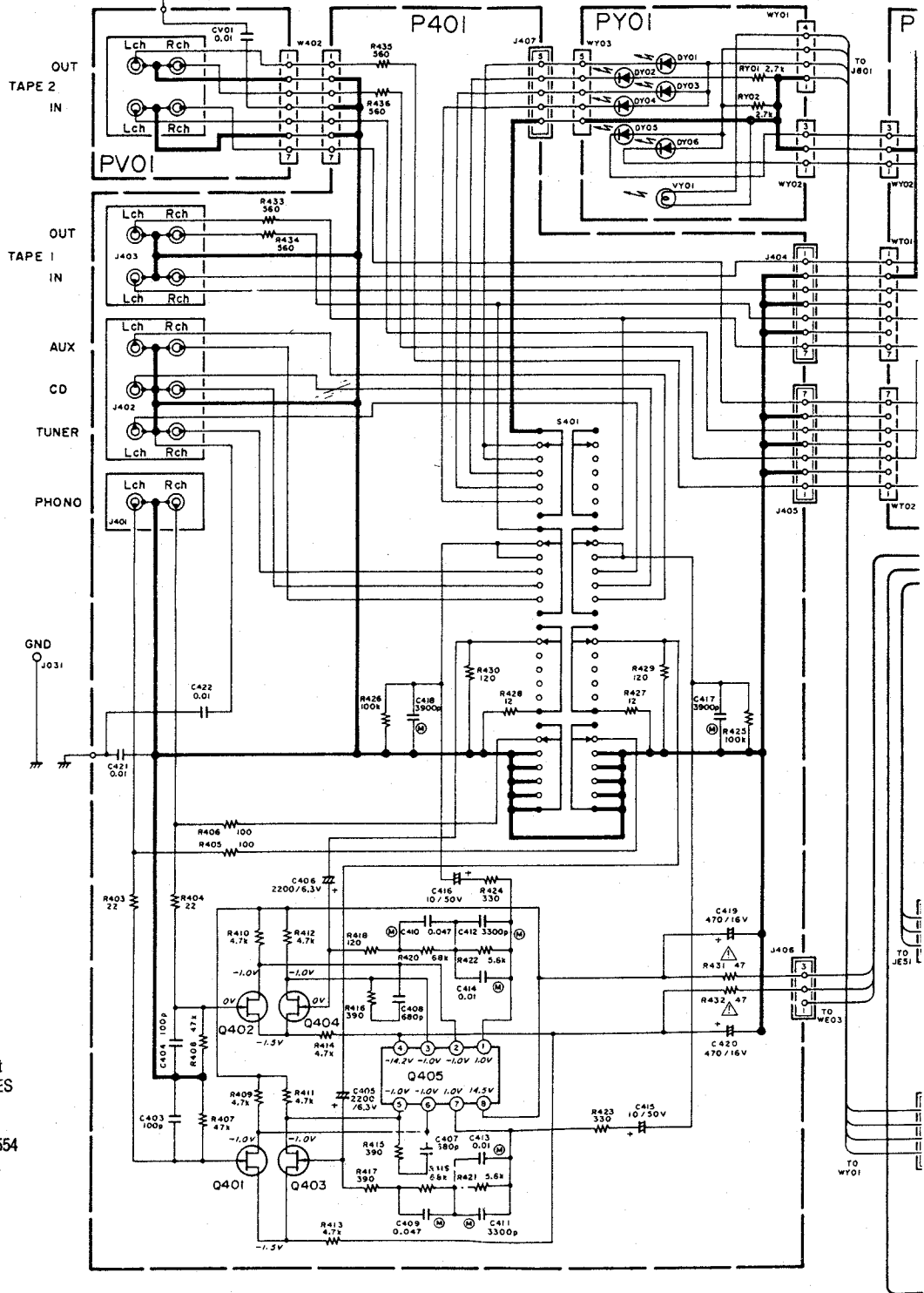

For Service Manuals Contact
MAURITRON TECHNICAL SERVICES
 8 Cherry Tree Rd, Chinnor
 Oxon OX9 4QY
 Tel:- 01844-351694 Fax:- 01844-352554
 Email:- enquiries@mauritron.co.uk

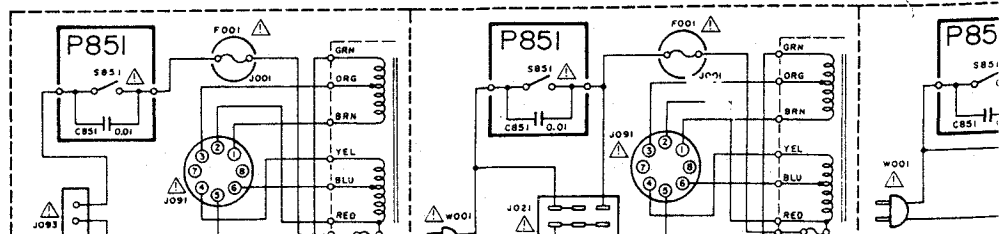

For Service Manuals Contact
MAURITRON TECHNICAL SERVICES
 8 Cherry Tree Rd, Chinnor
 Oxon OX9 4QY
 Tel: 01844-351694 Fax: 01844-352554
 Email: enquiries@mauritron.co.uk

- | | | | | | | | | | | | | |
|------|----------------------------------|--|--|---|---|---|---|---|--|--------------------------------|---|------------------------|
| QU53 | Q705
HC10145030
STK3102 II | Q709, Q710
HT326821P0
25C2682(P) | Q711, Q712
HT111421P0
2SA1142(P) | Q713, Q714
HT332982D0
25C3298
(O, Y) | Q715, Q716
HT113062D0
2SA1306
(O, Y) | Q717, Q718
HT327742B0
25C2774
(O, Y) | Q719, Q720
HT111702B0
2SA1170
(O, Y) | Q801
HT412662B0
25D1266
(Q, P) | Q802
HT209412B0
25B941
(Q, P) | QE01
HC10026090
NJM2041D | QN03~QN05
QU08, QU54
HT109922B0
2SA992
(F, E) | QN07
HC100
TA731 |
|------|----------------------------------|--|--|---|---|---|---|---|--|--------------------------------|---|------------------------|

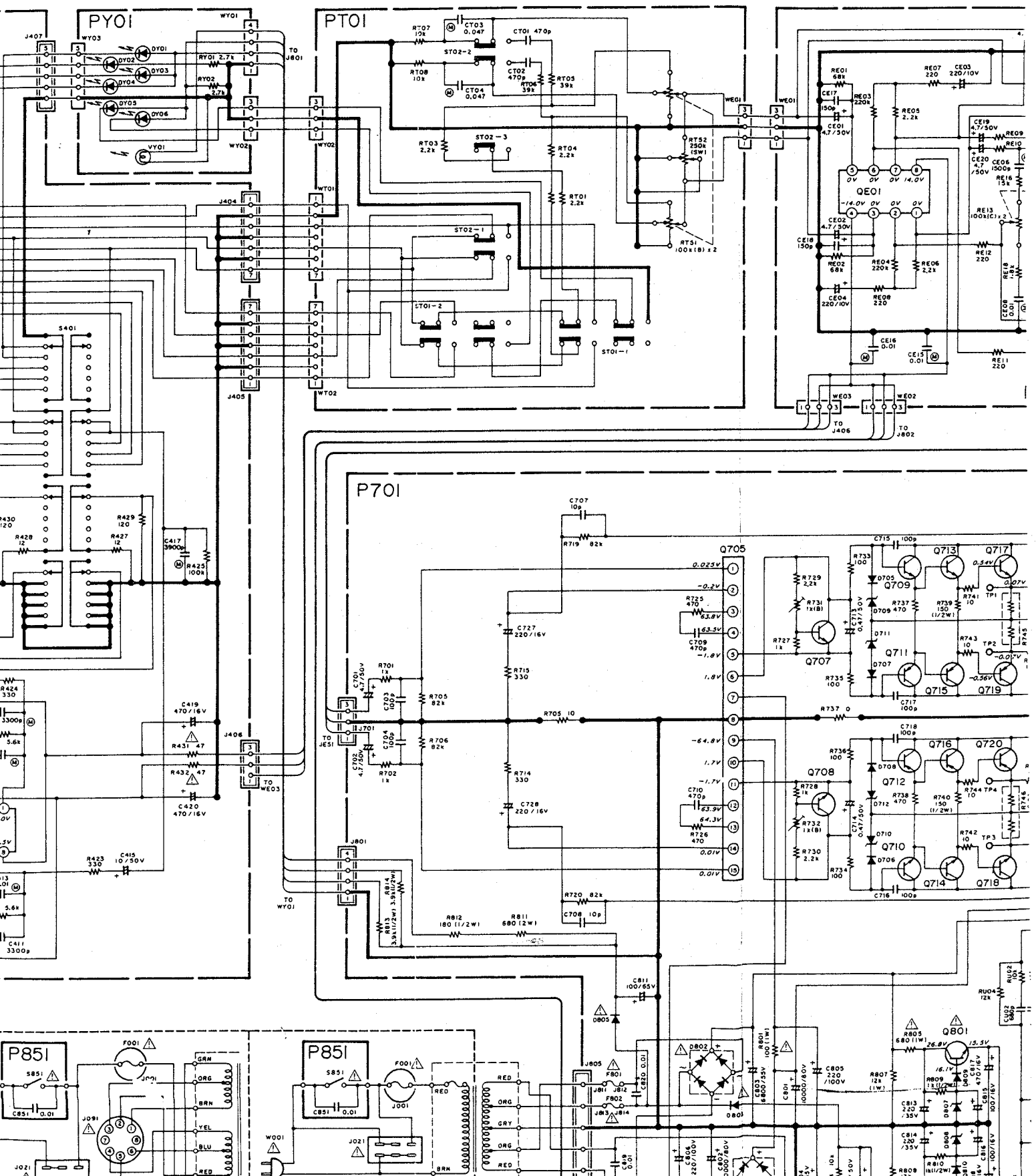

For Service Manuals Contact
MAURITRON TECHNICAL SERVICES
 8 Cherry Tree Rd, Chinnor
 Oxon OX9 4QY
 Tel: 01844-351694 Fax: 01844-352554
 Email: enquiries@mauritron.co.uk

- | | | | | | | | | | | | |
|--|---------------------------------------|--------------------------------|---|-------------------------------|--|---------------------------------------|----------------------------------|----------------------------------|--------------------------------|----------------------------------|---------------------------|
| Q801
HT412662B0
2SD1266
(Q,P) | Q802
HT209412B0
2SB941
(Q,P) | QE01
HC10026090
NJM2041D | QN03~QN05
QU08,QU54
HT109922B0
2SA992
(F,E) | QN07
HC10042050
TA7317P | QU03
HT412382B0
2SD1238
(R,S) | QU04
HT209222B0
2SB922
(R,S) | QU05
HT323441D0
2SC2344(D) | QU06
HT101011D0
2SA1011(D) | QU51
HC10022090
NJM2903D | QU52
HC712200A0
HA74LS122P | DU51
HD20002
IS2472 |
|--|---------------------------------------|--------------------------------|---|-------------------------------|--|---------------------------------------|----------------------------------|----------------------------------|--------------------------------|----------------------------------|---------------------------|

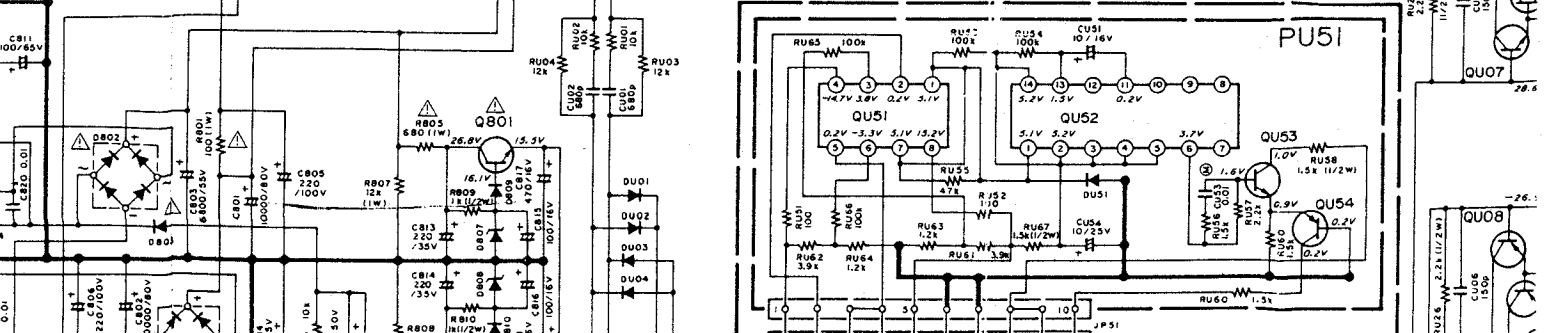
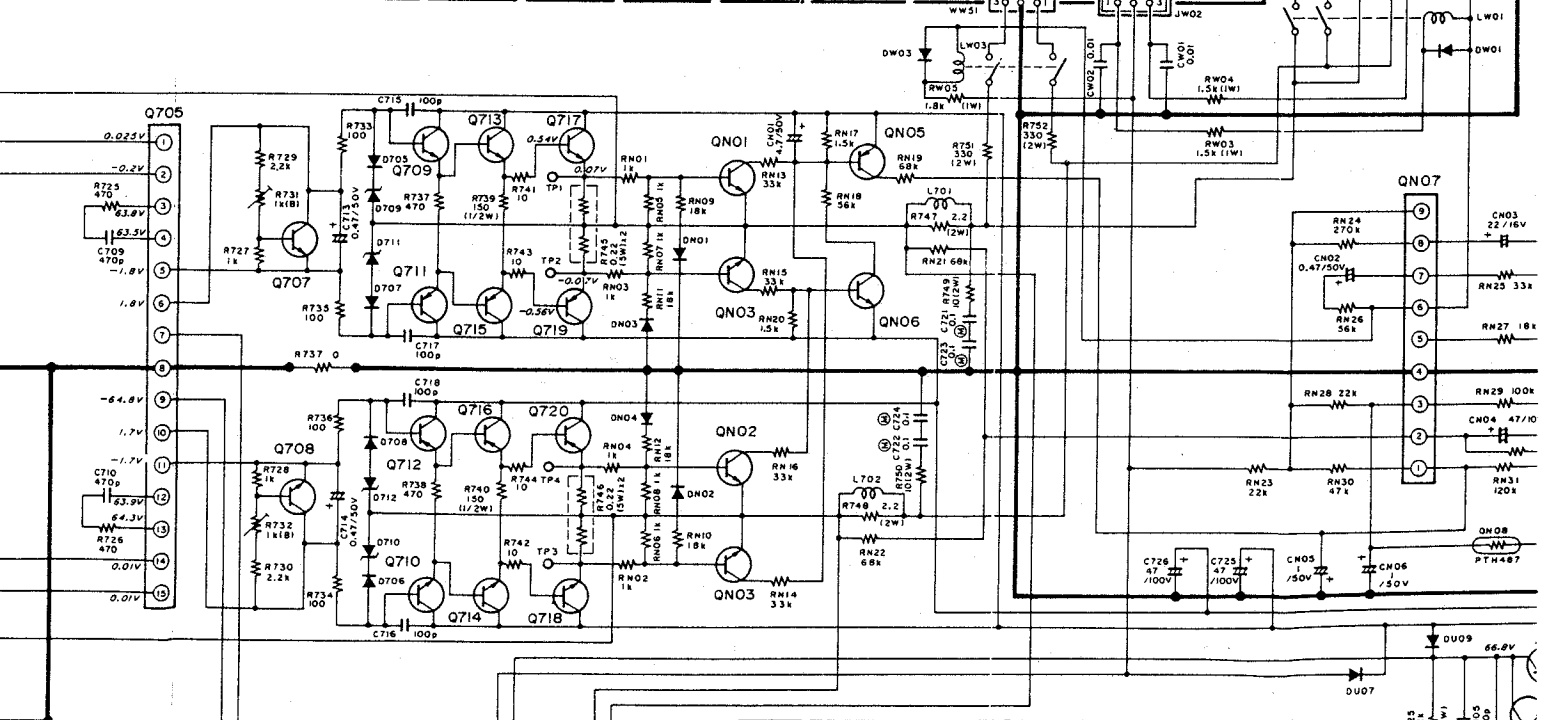
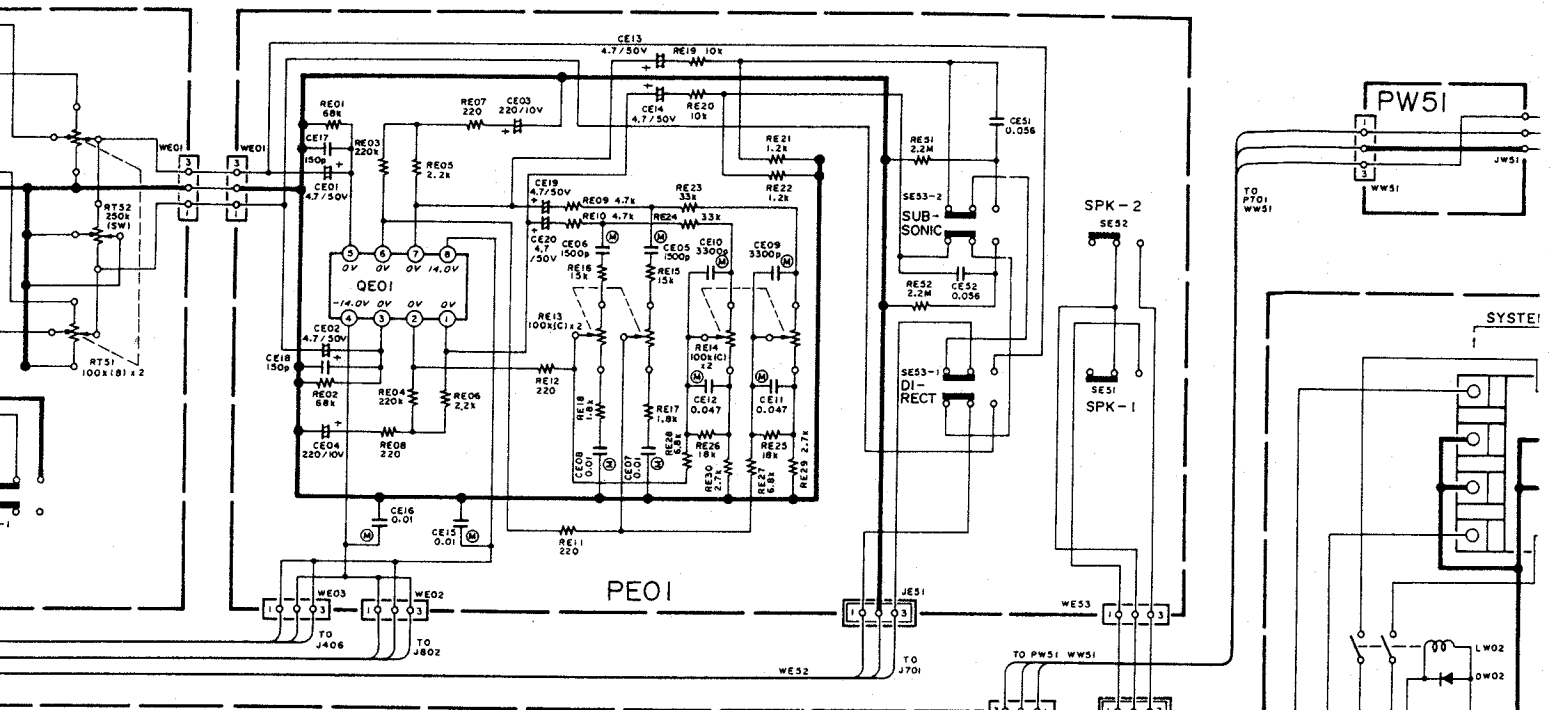

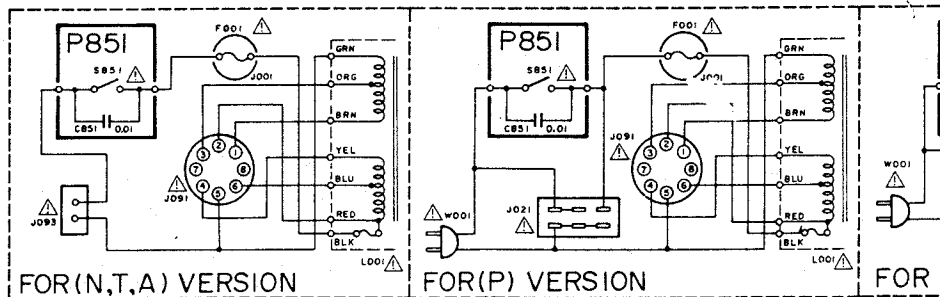
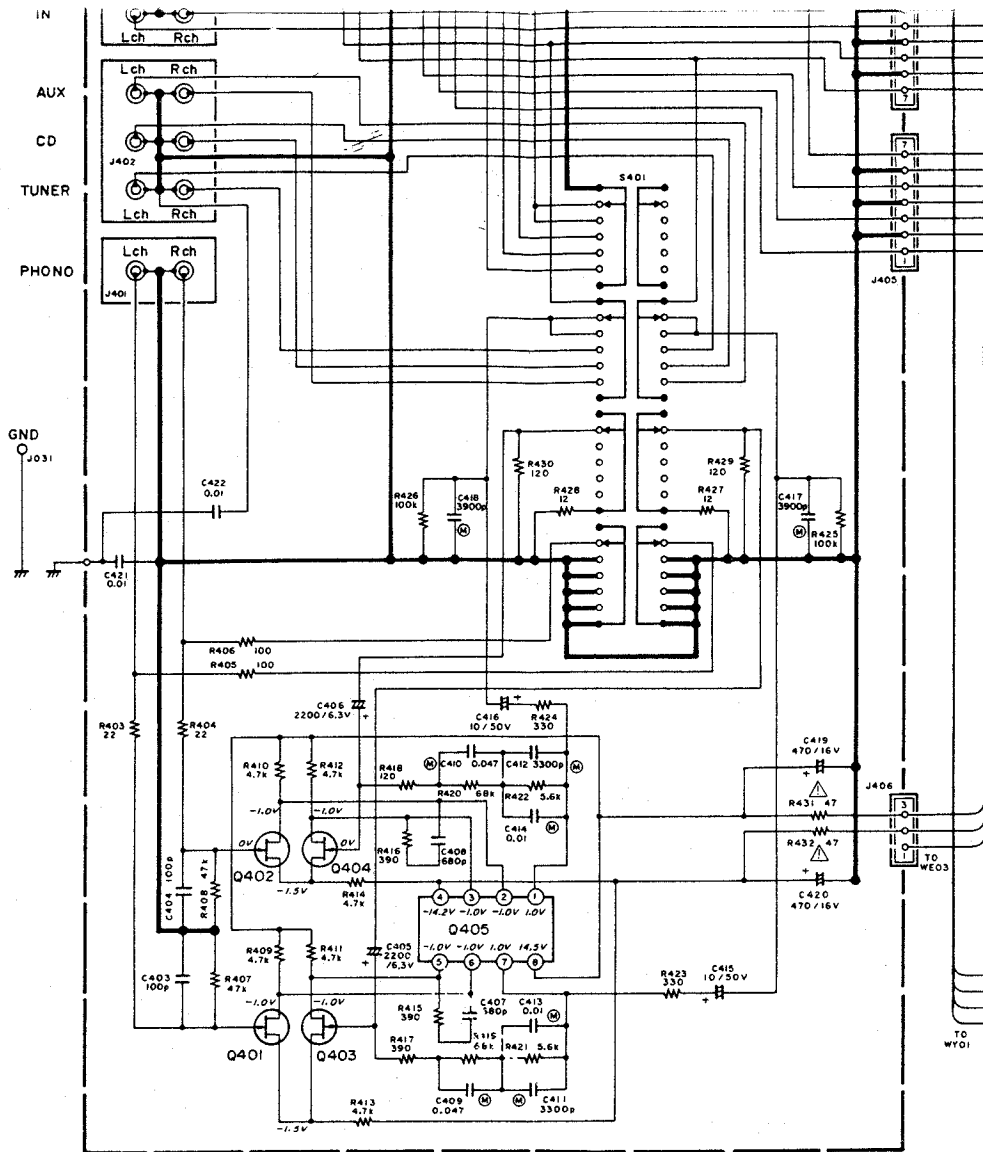

For Service Manuals Contact
MAURITRON TECHNICAL SERVICES
 8 Cherry Tree Rd, Chinnor
 Oxon OX9 4QY
 Tel:- 01844-351694 Fax:- 01844-352554
 Email:- enquiries@mauritron.co.uk



2SC1845 (F, E)
 Q707, Q708
 QN01, QN02, QN06, QU07, QU53

2SA992 (F, E)
 QN03 ~ QN05, QU08, QU54

2SC2682 (P)
 Q709, Q710

2SA1142 (P)
 Q711, Q712



2SK369 (BL)
 Q401 ~ Q404

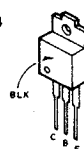

2SC3298 (O, Y)
 Q713, Q714

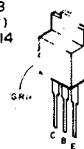

2SA1142 (P)
 Q715

NOTE ON SAFETY:

Symbol Δ Fire or electrical shock hazard. Only original parts should be used to replace any part marked with symbol Δ . Any other component substitution (other than original type), may increase risk of fire or electrical shock hazard.

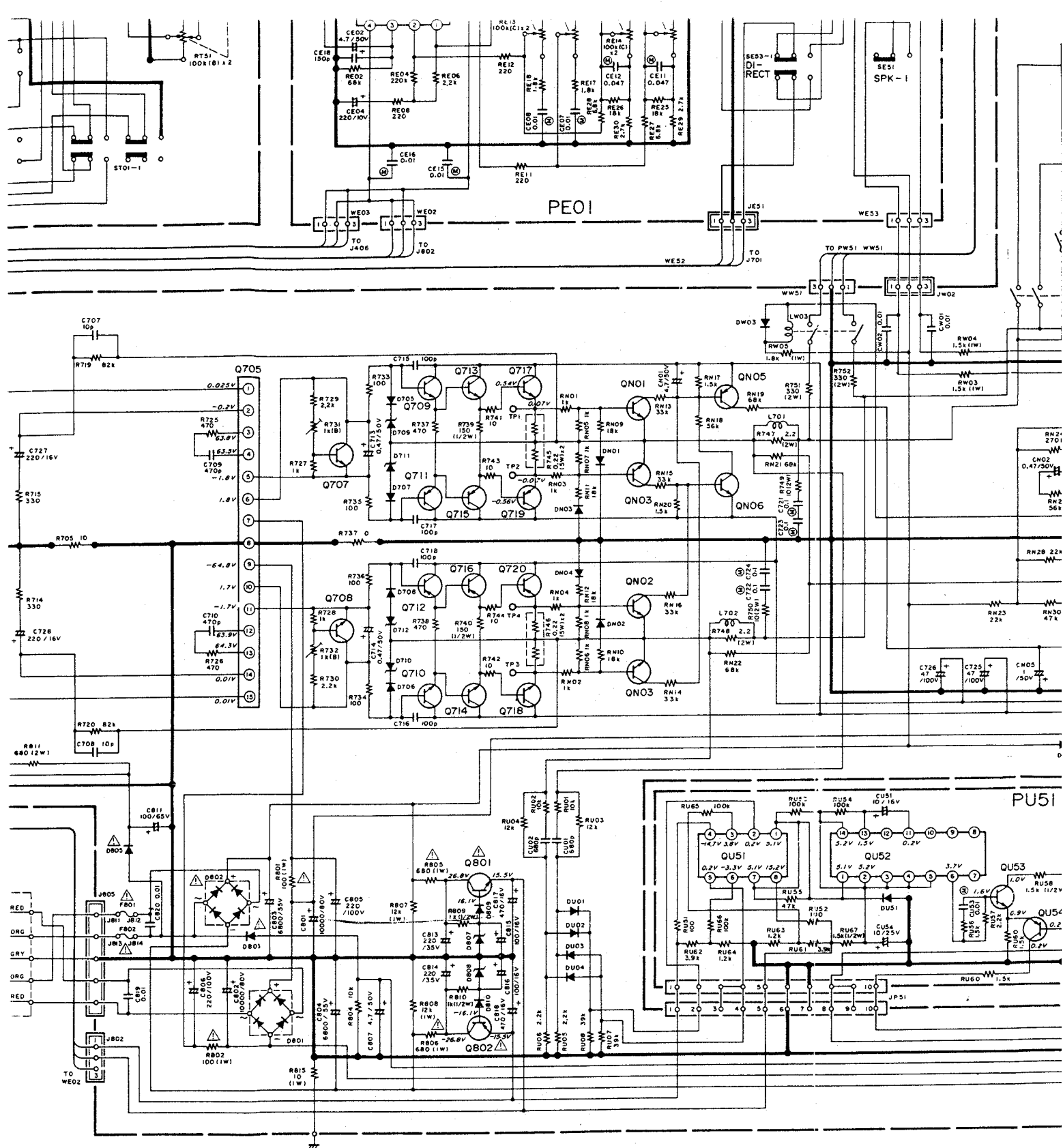

- 2SB922 (R,S) QU04
- 2SC2344 (D) QU05
- 2SA1011 (D) QU06
- 2SD1266 (Q,P) Q801
- 2SB941 (O,P) Q802
- NUM2043DD Q405
- NUM2041D QE01
- NUM2903D QU51
- TOP VIEW NUM2043DD Q405
- FRONT VIEW TAT7317P QN07
- TOP VIEW HA74LS122P QU52
- FRONT VIEW STK3102 Q705

For Service Manuals Contact
MAURITRON TECHNICAL SERVICES
 8 Cherry Tree Rd, Chinnor
 Oxon OX9 4QY
 Tel: 01844-351694 Fax: 01844-352554
 Email: enquiries@mauritron.co.uk

Components and wiring are subject to change for

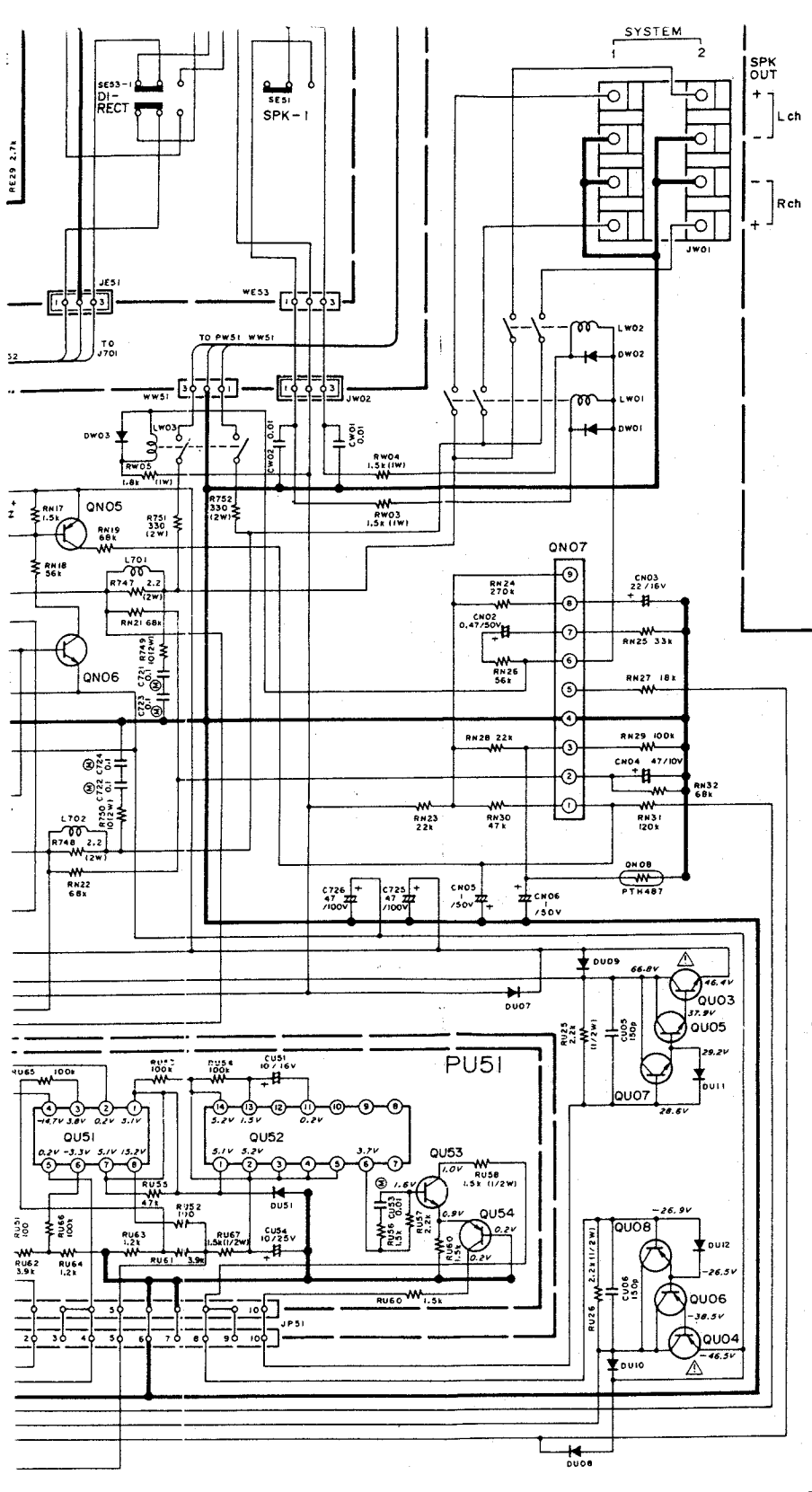

D807, D808
HD30051060
RD16E

DU07, DU08
HD20011290
S3VB20

DY01 - DY06
H110028320
GL-9HD4

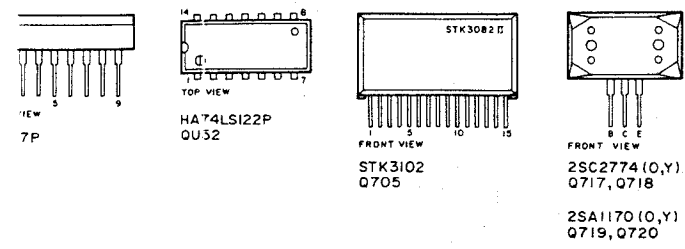

Components and wiring are subject to change for modification without notice.

Q401 ~ Q404	Q405	Q707, Q708	Q705	Q713, Q714	Q715, Q716	Q717, Q
HF203691B0	HC10017090	QN01, QN02, QN06, QU07, QU53	HC10145030	HT332982D0	HT113062D0	HT327
2SK369(BL)	NJM2043D0	HT318452B0	STX3102II	2SC3298	2SA1306	2SC27
		2SC1845 (F, E)		(O, Y)	(O, Y)	2SC27

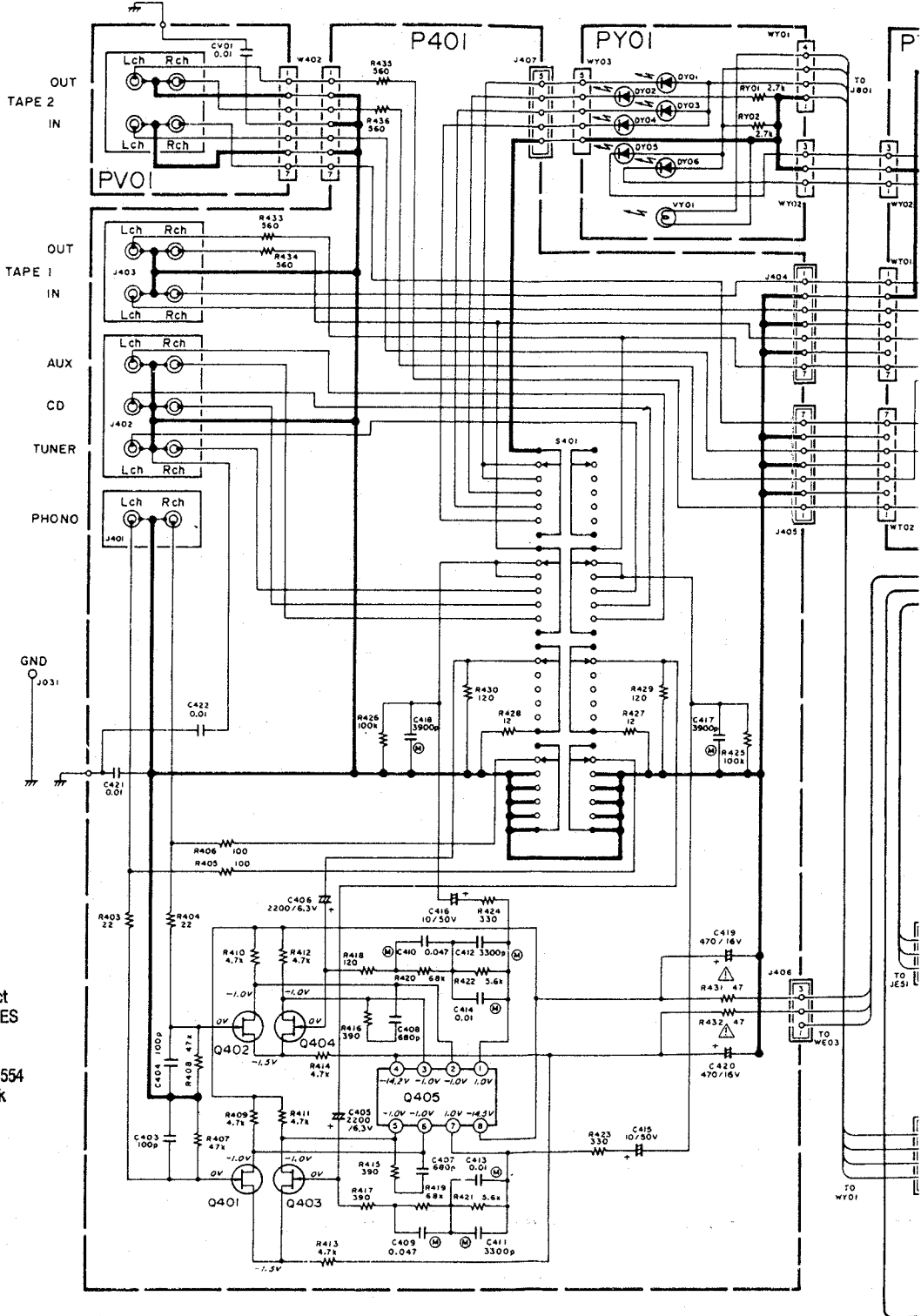

For Service Manuals Contact
MAURITRON TECHNICAL SERVICES
 8 Cherry Tree Rd, Chinnor
 Oxon OX9 4QY
 Tel:- 01844-351694 Fax:- 01844-352554
 Email:- enquiries@mauritron.co.uk

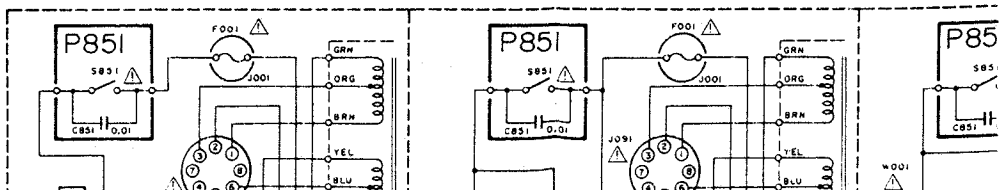

Q707, Q708
 QN01, QN02, QN06, QU07, QU53
 HT318452B0
 2SC1845 (F, E)

Q705
 HC10145030
 STK3102 II

Q713, Q714
 HT332982D0
 2SC3298
 (O, Y)

Q715, Q716
 HT113062D0
 2SA1306
 (O, Y)

Q717, Q718
 HT327732B0
 2SC2773
 (O, Y)

Q719, Q720
 HT111692B0
 2SA1169
 (O, Y)

Q801
 HT412662B0
 2SD1266
 (Q, P)

Q802
 HT209412B0
 2SB941
 (Q, P)

QE01
 HC10026090
 NJM2041D

QN03 ~ QN05
 QU08, QU54
 HT109922B0
 2SA992
 (F, E)

QN07
 HC10042050
 TA7317P

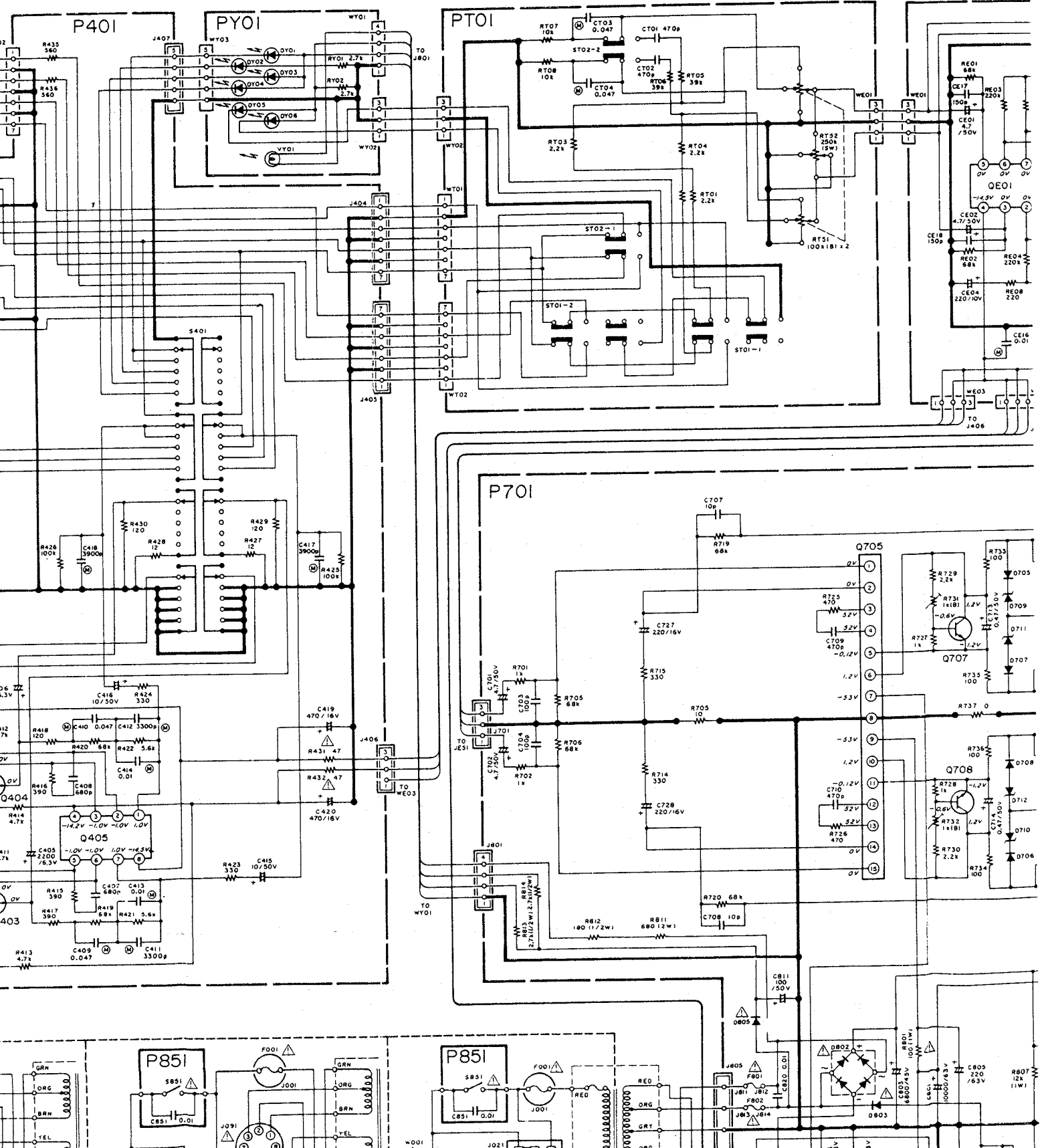

- | | | | | | | | | | | | |
|------------|------------|-------------|------------|------------|------------|------------|------------|------------|------------|------------|-------------------|
| 802 | QE01 | QN03 ~ QN05 | QN07 | QU03 | QU04 | QU05 | QU06 | QU51 | QU52 | OU51 | 0705 ~ 0708 |
| HT209412B0 | HC10026090 | QU08, QU54 | HC10042050 | HT412382B0 | HT209922B0 | HT323441D0 | HT110111D0 | HC10022090 | HC712200A0 | HD20002210 | 0803, 0N01 ~ 0N0 |
| SB941 | NJM2041D | HT109922B0 | TA7317P | 25D1233 | 25B992 | 25C2344(D) | 25A1011(D) | NJM2903D | HA74LS122P | IS2472 | 0U01 ~ 0U04, 0U11 |
| (Q,P) | | 2SA992 | (F,E) | (R,S) | (R,S) | | | | | | DUI2, DW01 ~ DW0 |
| | | | | | | | | | | | HD20003210 |
| | | | | | | | | | | | IS2471 |

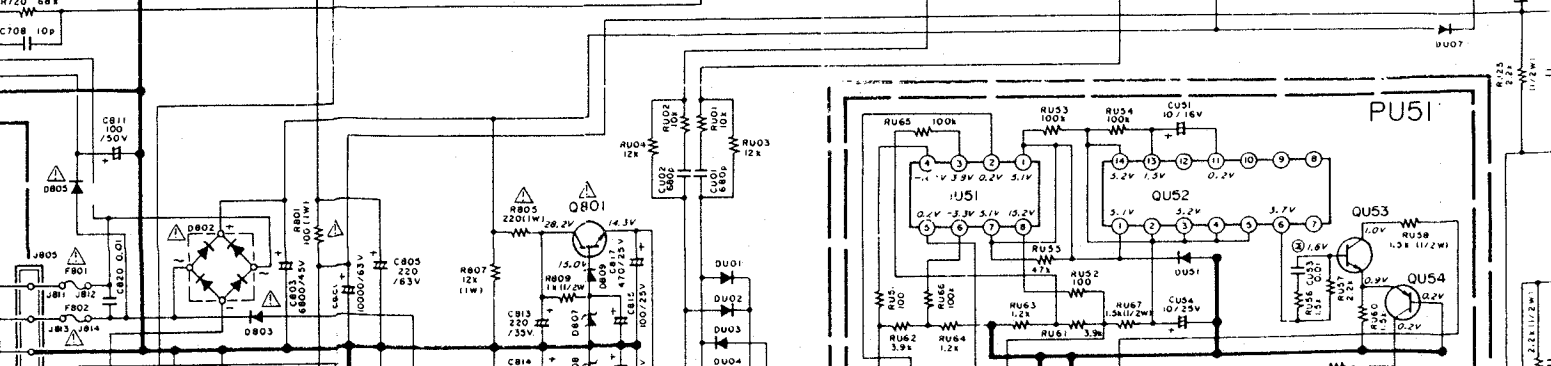
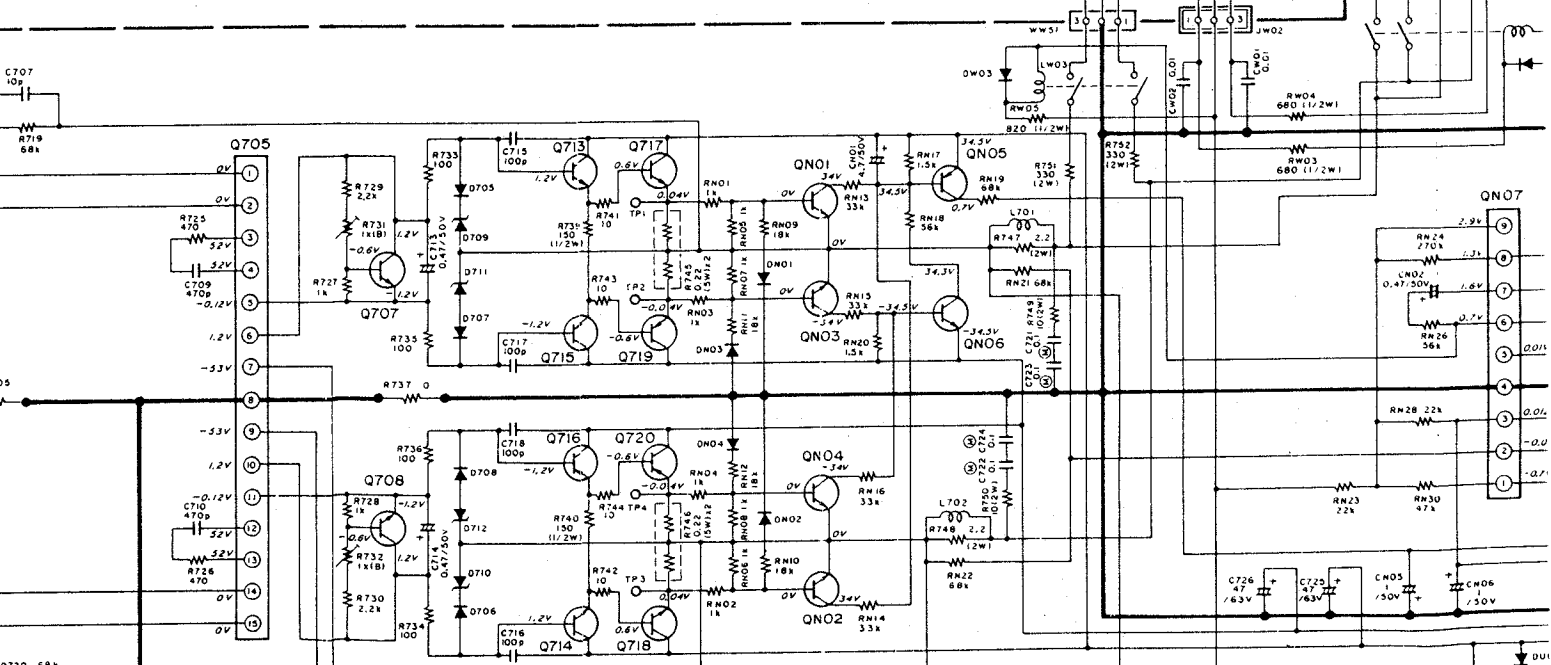
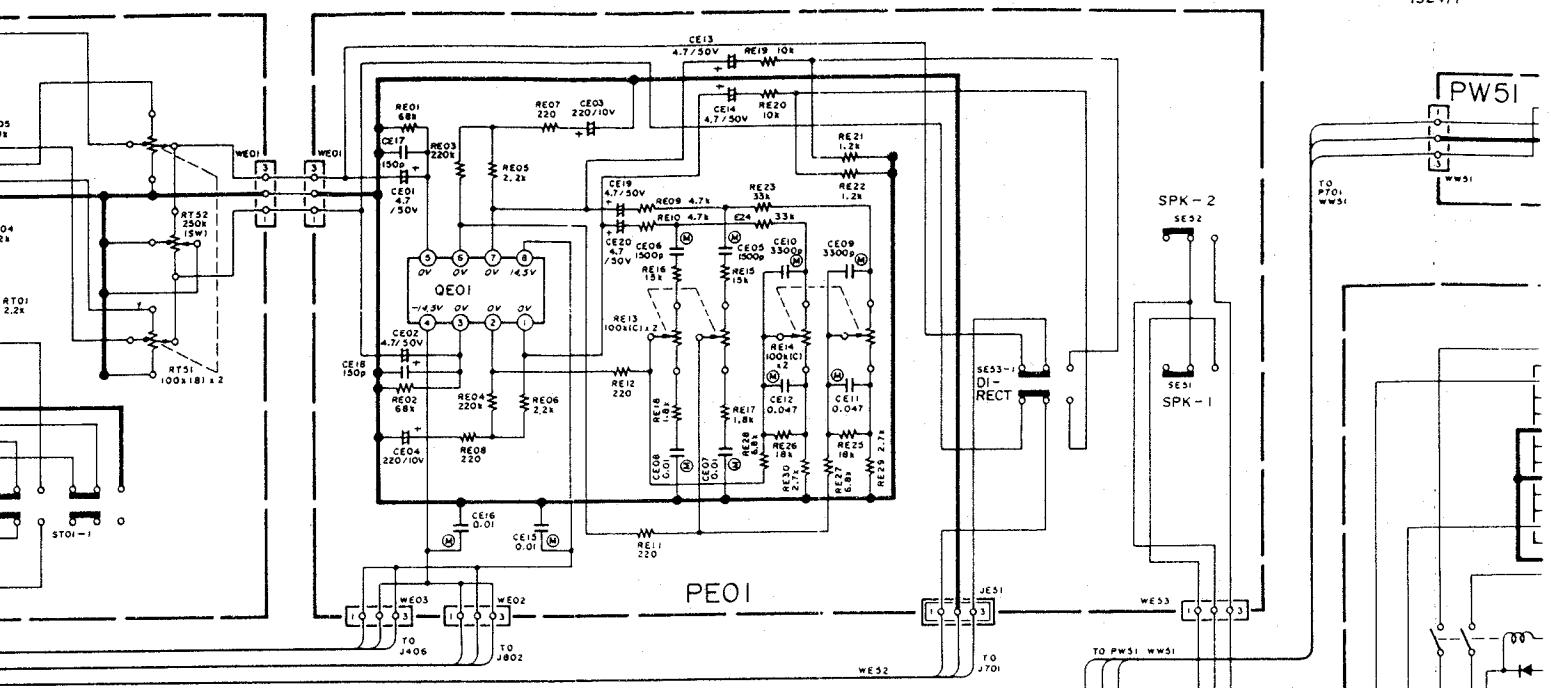

MODEL PM-54

QU51 HC10022090
 NJM2903D
 QU52 HC712200A0
 HA74LS122P
 DU51 HD20002210
 IS2472
 D705 ~ D708
 D803, DN01 ~ DN04
 DU01 ~ DU04, DU11
 DU12, DW01 ~ DW03
 HD20003210
 IS2471
 D709 ~ D712
 HD30064060
 RD6.2E
 D805
 DU09, DU10
 HD20022030
 DSF10C
 D801
 HE2009290
 S5VB20

D802
 HD20008290
 S4VB20



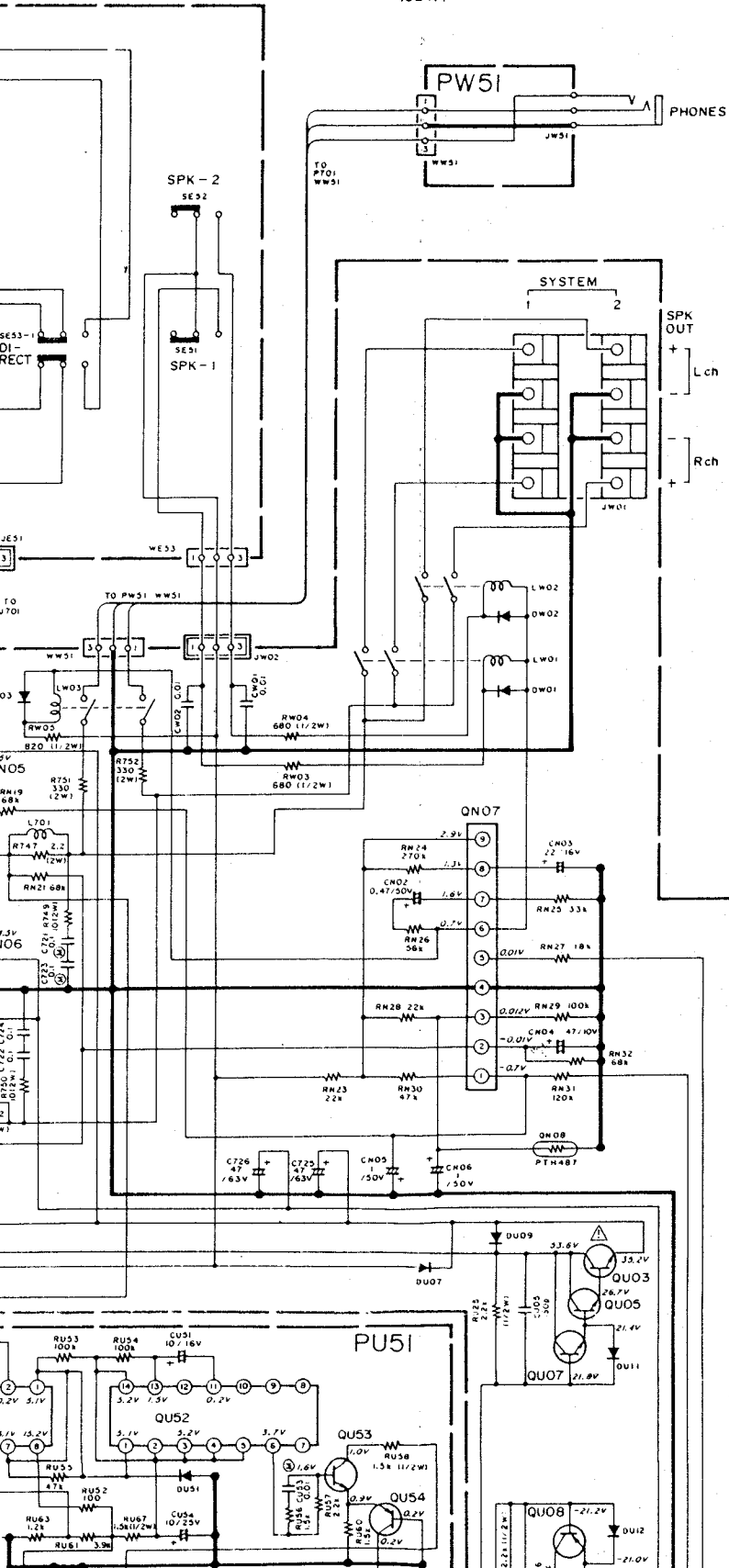

D807, D808
 HD30051060
 RD16E

DU07, DU08
 HD20011290
 S3VB20

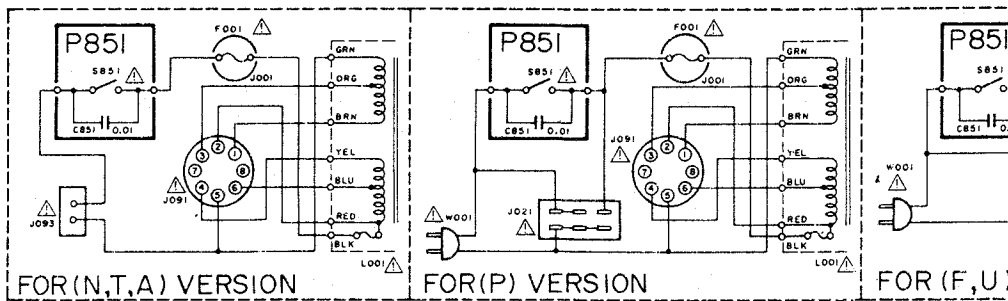
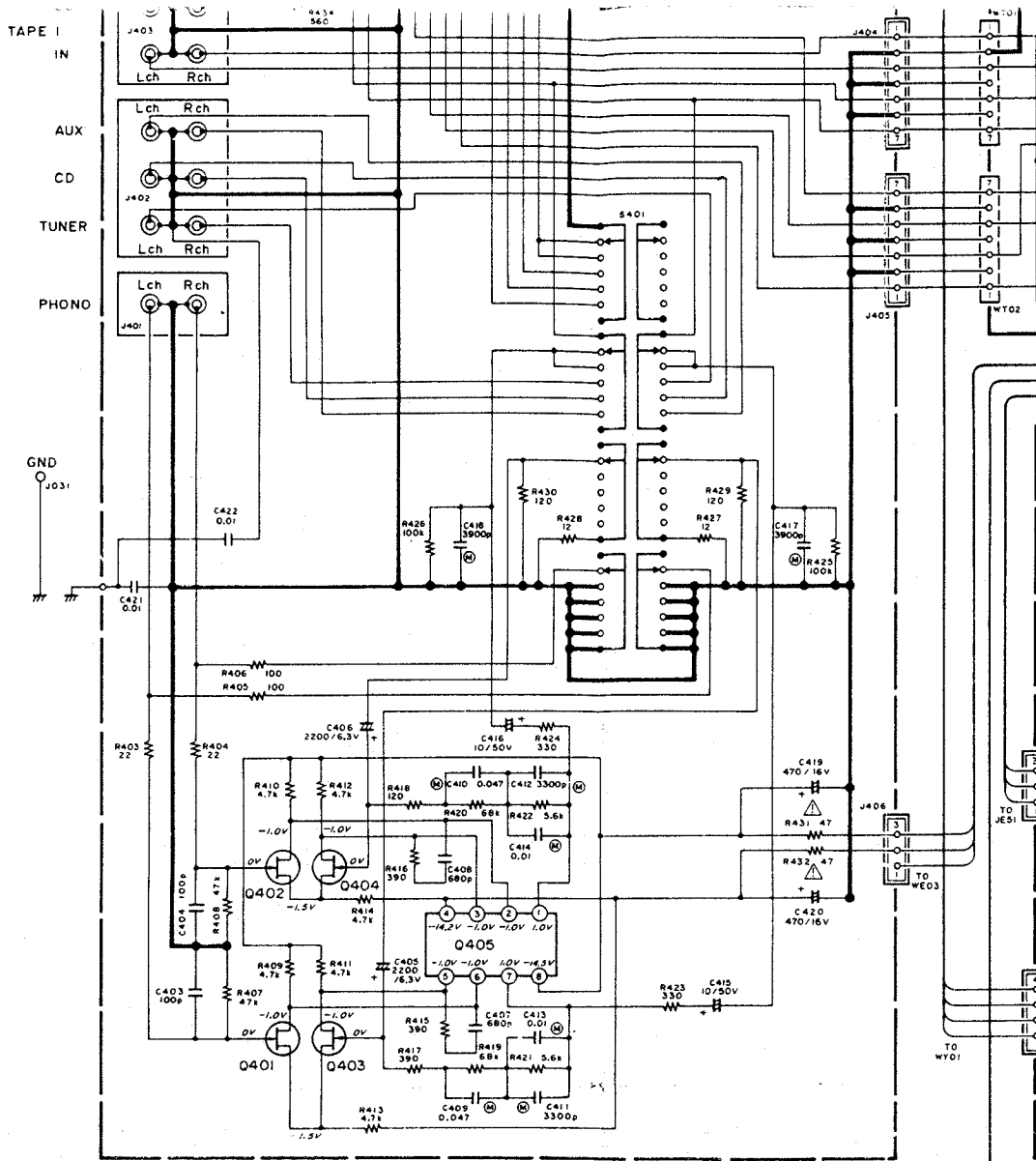
DY01 ~ DY06
 H110028320
 GL-9HD4

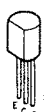

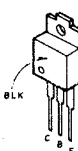
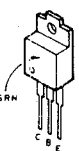

- | | | | |
|---|--|--|--|
|  <p>2SC1845 (F, E)
Q707, Q708
QN01, QN02, QN06, QU07, QU53</p> |  <p>2SK369 (BL)
Q401~Q404</p> |  <p>2SC3298 (O, Y)
Q713, Q714</p> |  <p>2SA1306 (O, Y)
Q715, Q716</p> |
|  <p>2SA992 (F, E)
QN03~QN05
QU08, QU54</p> | | | |

NOTE ON SAFETY:

Symbol Δ Fire or electrical shock hazard. Only original parts should be used to replace any part marked with symbol Δ . Any other component substitution (other than original type), may increase risk of fire or electrical shock hazard.

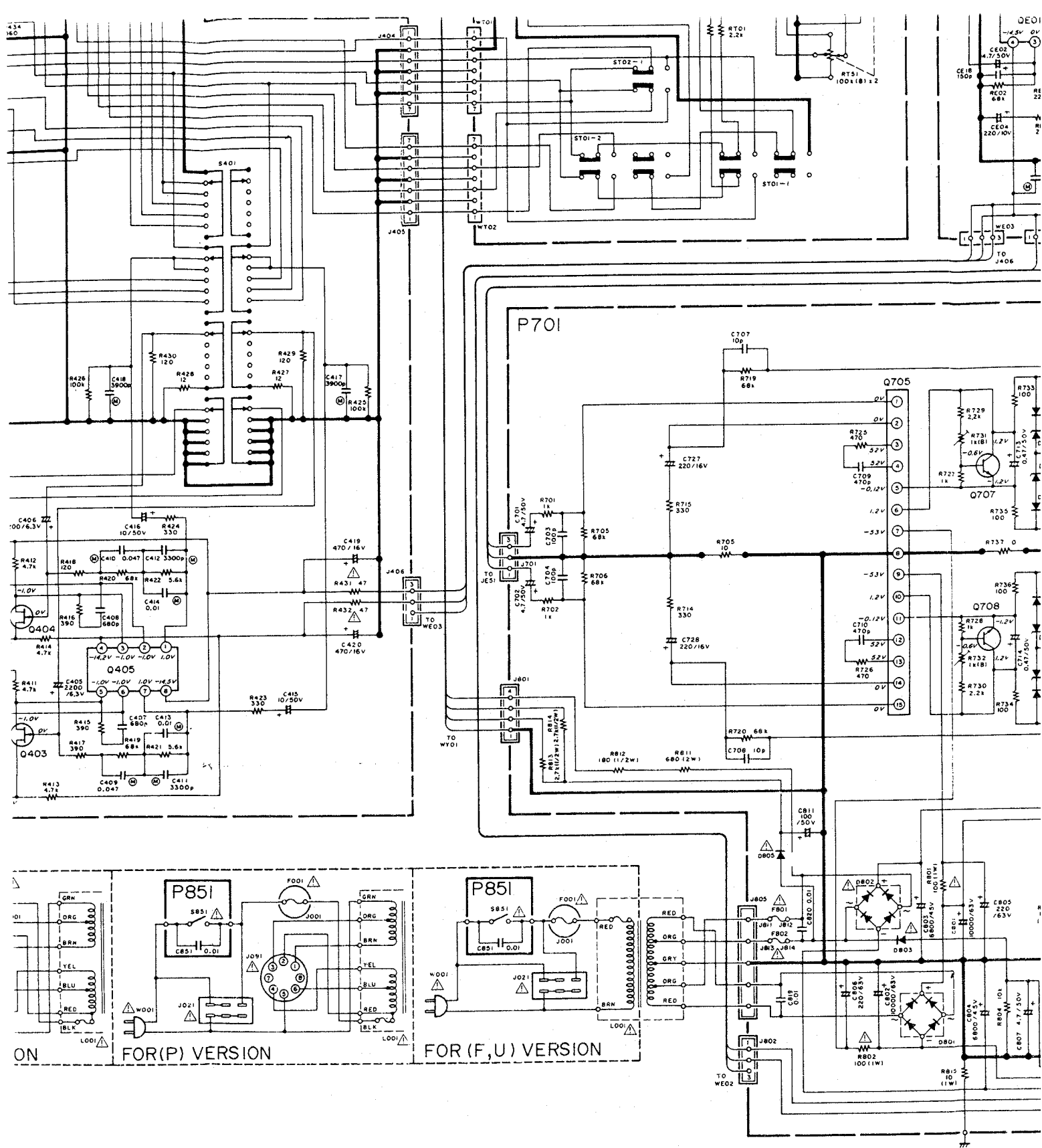

- 1B45 (F,E)
- 7,0708
- 11,0N02,0N06,0U07,0U53



2SK369 (BL)
Q401-Q404

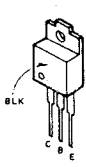

2SC3298 (O,Y)
Q713,Q714



2SA1306 (O,Y)
Q715,Q716

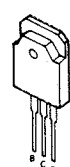

2SD1238 (R,S)
QU03

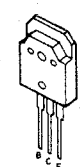

2SB922 (R,S)
QU04

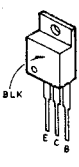

2SC2344 (D)
QU05

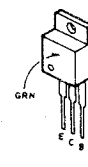

2SA1011 (D)
QU06

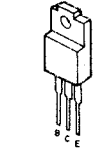

ON SAFETY:

! Δ Fire or electrical shock hazard. Only original parts be used to replace any part marked with symbol Δ . Other component substitution (other than original) may increase risk of fire or electrical shock hazard.

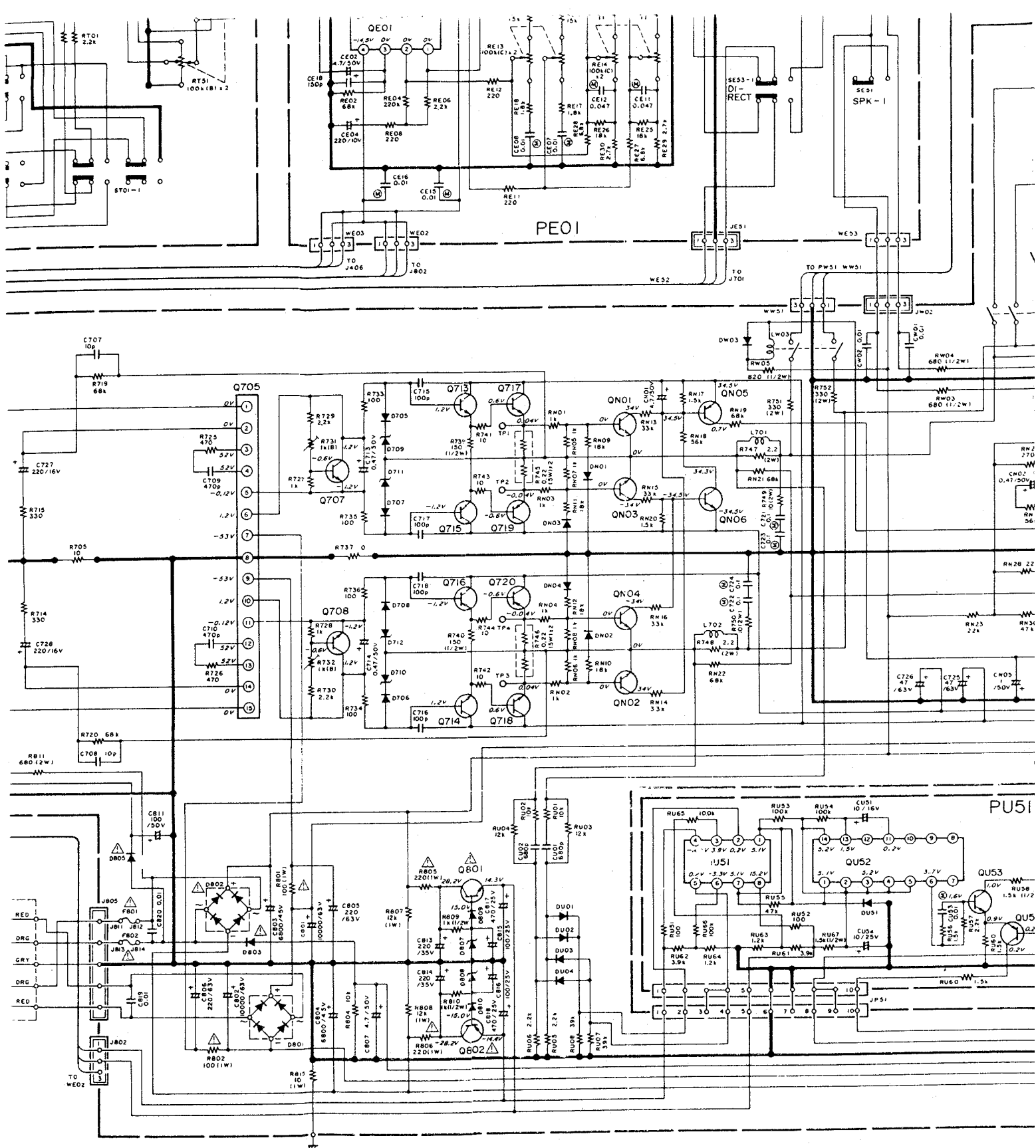

- 2SB922 (R,S) QU04
- 2SC2344 (D) QU05
- 2SA1011 (D) QU06
- 2SD1266 (Q,P) Q801
- 2SB941 (Q,P) Q802
- NJM2043DD Q405
- NJM2041D QE01
- NJM2903D QU51
- TA7317P QN07
- HA74LS122P QU52
- STK3082 II
- STK3102 II Q705

Components and wiring are subject to change for mod

DY01 ~ DY06
H110028320
GL-9H04

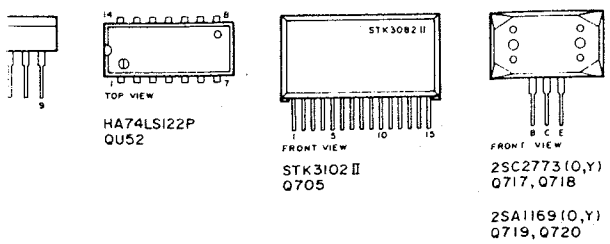
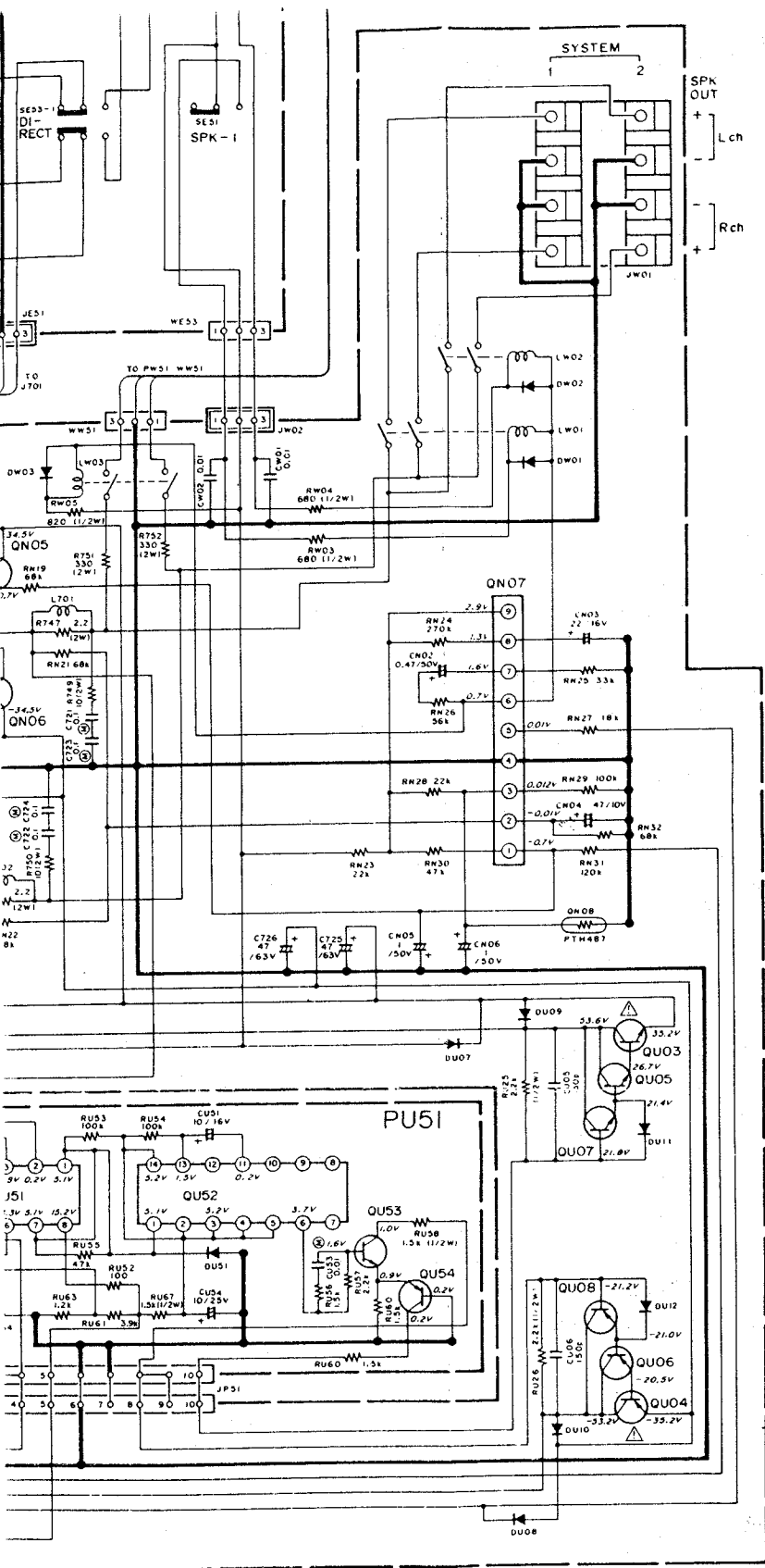

ents and wiring are subject to change for modification without notice.