

# JVC

## SERVICE MANUAL

### 36cm (14") COLOUR TV

# C-14M1

BASIC CHASSIS

KY

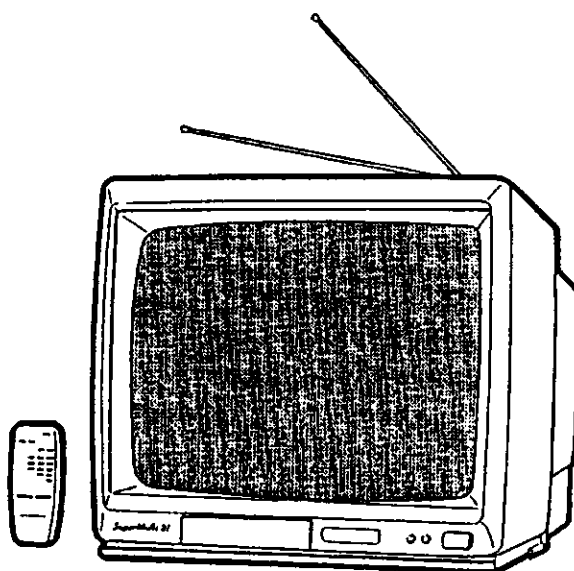

## CONTENTS

|  |          |
|--|----------|
| ■ SPECIFICATIONS .....                   | 2        |
| ■ SAFETY PRECAUTIONS .....               | 3        |
| ■ FEATURES .....                         | 4        |
| ★ OPERATING INSTRUCTIONS(APPENDED) ..... | 3-1~3-16 |
| ■ SPECIFIC SERVICE INSTRUCTIONS .....    | 5        |
| ■ SERVICE ADJUSTMENT .....               | 7        |
| ■ PARTS LIST .....                       | 15       |
| ★ SCHEMATIC DIAGRAM(APPENDED) .....      | 2-1~2-24 |

# C-14M1 STANDARD CIRCUIT DIAGRAM

## NOTE ON USING CIRCUIT DIAGRAMS

### 1. SAFETY

The components identified by the  $\triangle$  symbol and shading are critical for safety. For continued safety replace safety critical components only with manufactures recommended parts.

### 2. SPECIFIED VOLTAGE AND WAVEFORM VALUES

The voltage and waveform values have been measured under the following conditions.

- (1) Input signal : PAL Color bar signal
- (2) Setting positions of each knob/button and variable resistor : Original setting position when shipped
- (3) Internal resistance of tester : DC 20k $\Omega$ /V
- (4) Oscilloscope sweeping time : H  $\Rightarrow$  20 $\mu$ S/div  
: V  $\Rightarrow$  5mS/div  
: Others  $\Rightarrow$  Sweeping time is specified
- (5) Voltage values : All DC voltage values
- \* Since the voltage values of signal circuit vary to some extent according to adjustments, use them as reference values.

### 3. INDICATION OF PARTS SYMBOL [EXAMPLE]

- In the PW board : R1209  $\rightarrow$  R209

### 4. INDICATIONS ON THE CIRCUIT DIAGRAM

#### (1) Resistors

- Resistance value
  - No unit :  $\{\Omega\}$
  - K :  $\{K\Omega\}$
  - M :  $\{M\Omega\}$

- Rated allowable power
  - No indication : 1/6[W]
  - Others : As specified

#### • Type

- No indication : Carbon resistor
- OMR : Oxide metal film resistor
- MFR : Metal film resistor
- MPR : Metal plate resistor
- UNFR : Uninflammable resistor
- FR : Fusible resistor

\* Composition resistor 1/2 [W] is specified as 1/2S or Comp.

#### (2) Capacitors

- Capacitance value
  - 1 or higher :  $\{pF\}$
  - less than 1 :  $\{\mu F\}$
- Withstand voltage
  - No indication : DC50[V]
  - Others : DC withstand voltage[V]
  - AC indicated : AC withstand voltage[V]

#### \* Electrolytic Capacitors

47/50 [Example]: Capacitance value [ $\mu F$ ]/withstand voltage [V]

#### • Type

- No indication : Ceramic capacitor
- MY : Mylar capacitor
- MM : Metalized mylar capacitor
- PP : Polypropylene capacitor
- MPP : Metalized polypropylene capacitor
- MF : Metalized film capacitor
- TF : Thin film capacitor
- BP : Bipolar electrolytic capacitor
- TAN : Tantalum capacitor

#### (3) Coils

- No unit :  $\{\mu H\}$
- Others : As specified

#### (4) Power Supply

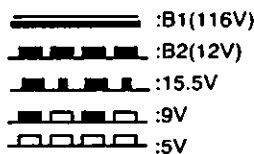

\* Respective voltage values are indicated.

#### (5) Test Point

- : Test point
- : Only test point display

#### (6) Connecting method

- : Connector
- : Wrapping or soldering
- : Receptacle

#### (7) Ground symbol

- : LIVE side ground
- : NEUTRAL side ground
- : EARTH ground
- : DIGITAL ground

### 5. NOTE FOR REPAIRING SERVICE

This model's power circuit is partly different in the GND. The difference of the GND is shown by the LIVE (primary :  $\perp$ ) side GND and the NEUTRAL (secondary :  $\nearrow$ ) side GND. Therefore, care must be taken for the following points.

- (1) Do not touch the LIVE side GND or the LIVE side GND and the NEUTRAL side GND simultaneously. If the above caution is not respected, an electric shock may be caused. Therefore, make sure that the power cord is surely removed from the receptacle when, for example, the chassis is pulled out.
- (2) Do not short between the LIVE side GND and NEUTRAL side GND or never measure with a measuring apparatus (oscilloscope, etc.) the LIVE side GND and NEUTRAL side GND at the same time. If the above precaution is not respected, a fuse or any parts will be broken.

◇ Since the circuit diagram is a standard one, the circuit and circuit constants may be subject to change for improvement without any notice.

SEMICONDUCTOR SHAPES



2SC1740S(QR)  
DTC124ES  
2SA933S(QR)



2SC1815(B)  
2SC1959(Y)



2SC1360  
2SA1013(RO)  
2SC2655(Y)  
2SA966  
2SA1370(E)  
2SC2229(Y)  
2SA966(OY)  
2SC1627A(OY)



2SK301(P)



SFOR1A42



2SD1555-C1  
2SD1274A-C1



2SC2068



2SC4502

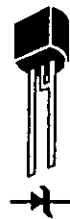

IC  
μPC574J



IC  
AN78L05



IC  
PST529E

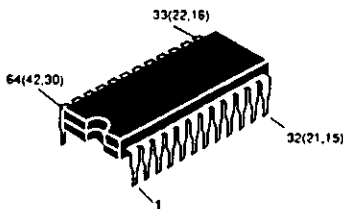

IC  
M37102M8-548SP  
TA8659AN

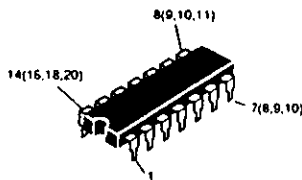

IC  
MC14066BCP  
M51496P  
M51320P

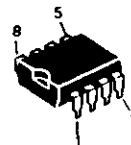

IC  
M6M80041P

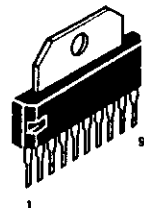

IC  
AN5265



IC  
AN7812



IC  
STR54041S

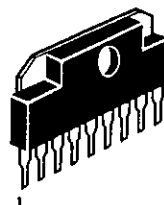

IC  
μPC1488H

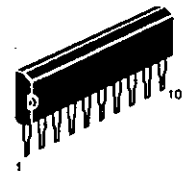

IC  
LA7210

MAIN PARTS LOCATION AND ALIGNMENTS LOCATION

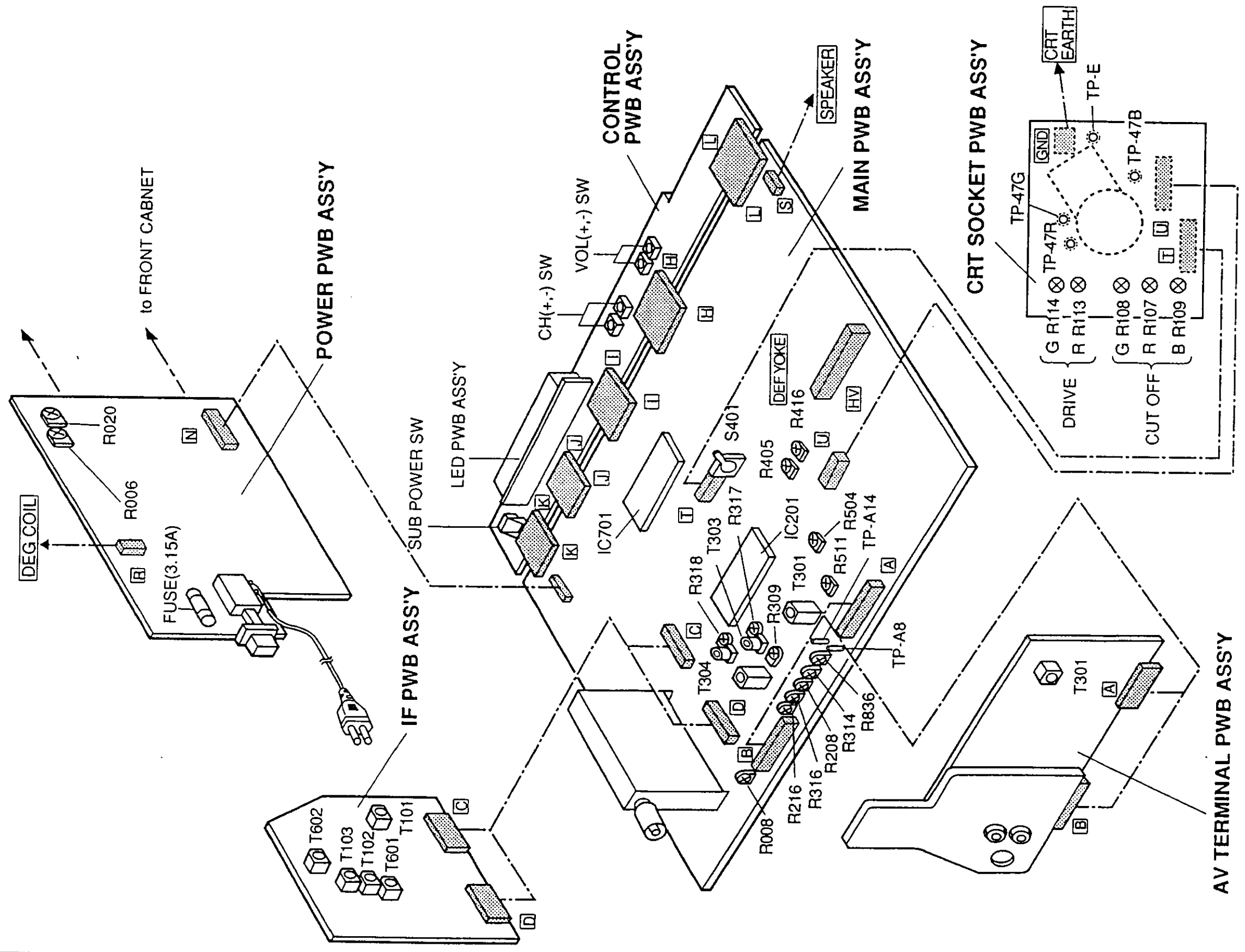

## WIRING LIST

| CONNECTOR | P.W.B. or PART | CONNECTOR | P.W.B. or PART |
|-----------|----------------|-----------|----------------|
| A         | SKY-1002A      | A         | SKY-7002A      |
| B         | SKY-1002A      | B         | SKY-7002A      |
| C         | SKY-1002A      | C         | SKY-1F001A     |
| D         | SKY-1002A      | D         | SKY-1F001A     |
| H         | SKY-1002A      | H         | SKY-8002A      |
| I         | SKY-1002A      | I         | SKY-8002A      |
| J         | SKY-1002A      | J         | SKY-8002A      |
| K         | SKY-1002A      | K         | SKY-8002A      |
| L         | SKY-1002A      | L         | SKY-8002A      |
| N         | SKY-1002A      | N         | SKY-9002A      |
| R         | SKY-9002A      |           | DEG. COIL      |
| S         | SKY-1002A      |           | SPEAKER        |
| T         | SKY-1002A      | T         | SKY-3002A      |
| U         | SKY-1002A      | U         | SKY-3002A      |
| HV        | SKY-1002A      |           | DEF. YOKE      |
| GND       | SKY-1002A      |           | CRT            |

### BLOCK DIAGRAM

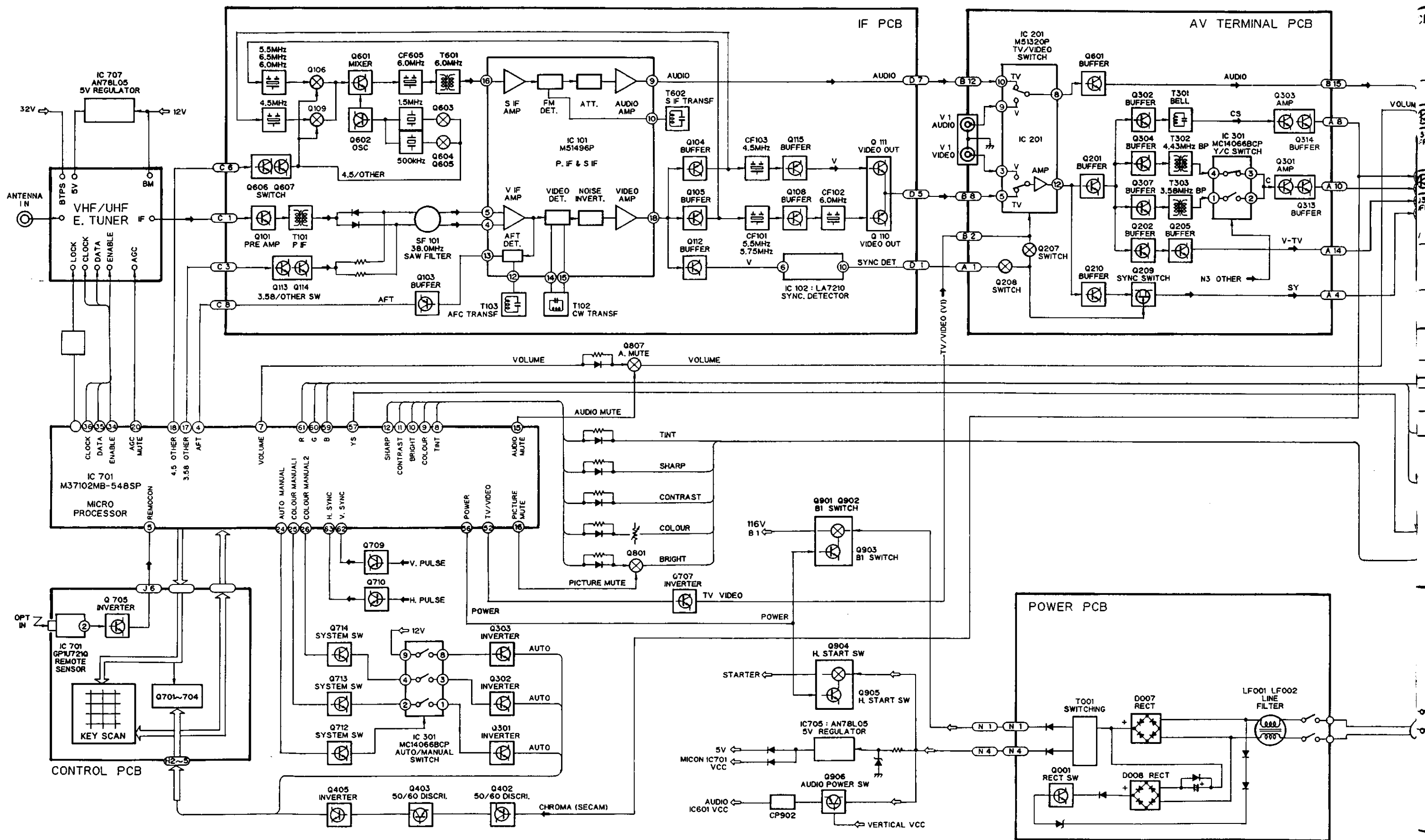

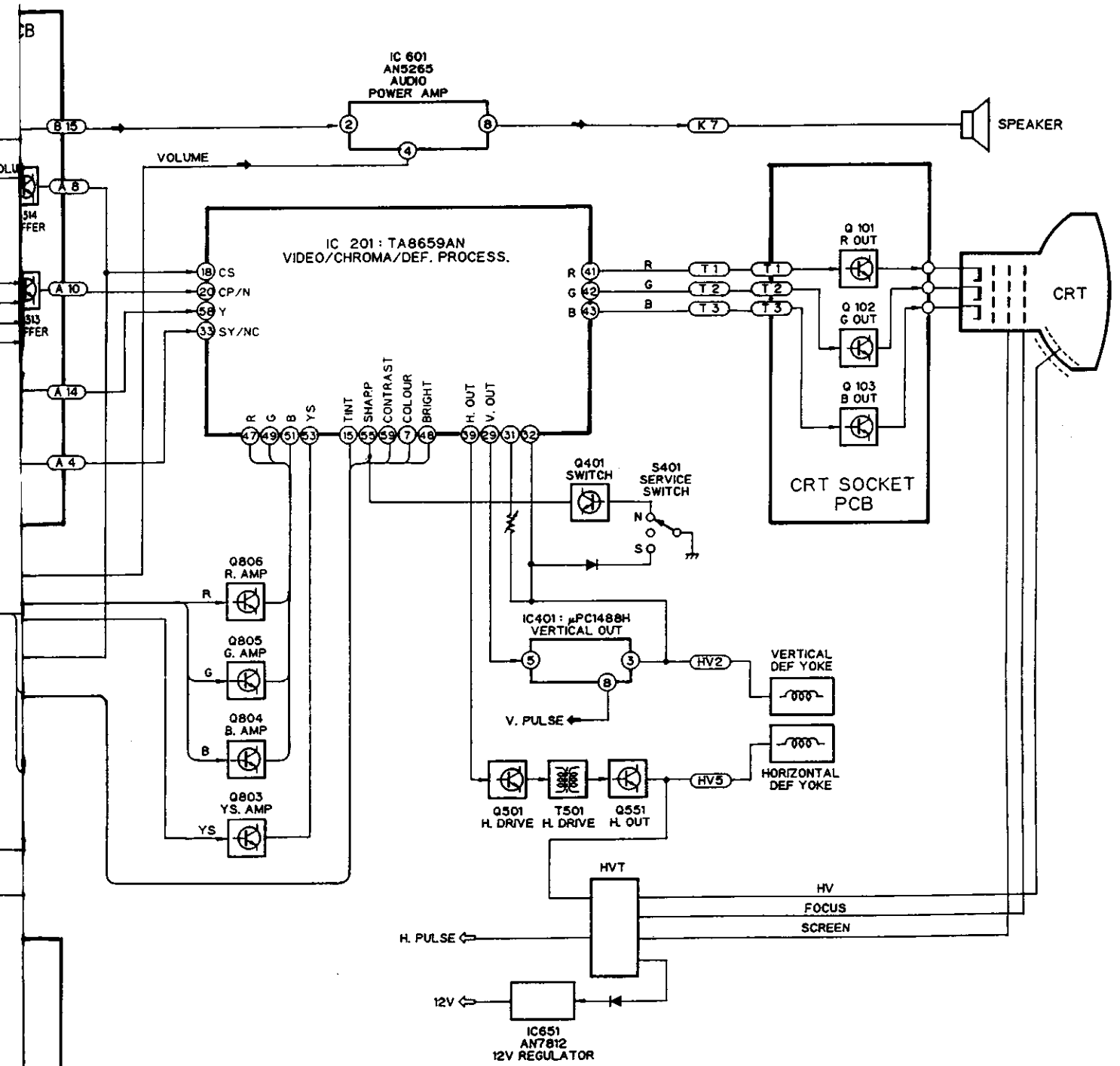

CIRCUIT DIAGRAMS AND PWB PATTERNS

AV TERMINAL PWB CIRCUIT DIAGRAMS

REFER TO THE FOLLOWING PWB PATTERN; AV TERMINAL PWB 2-20 page.

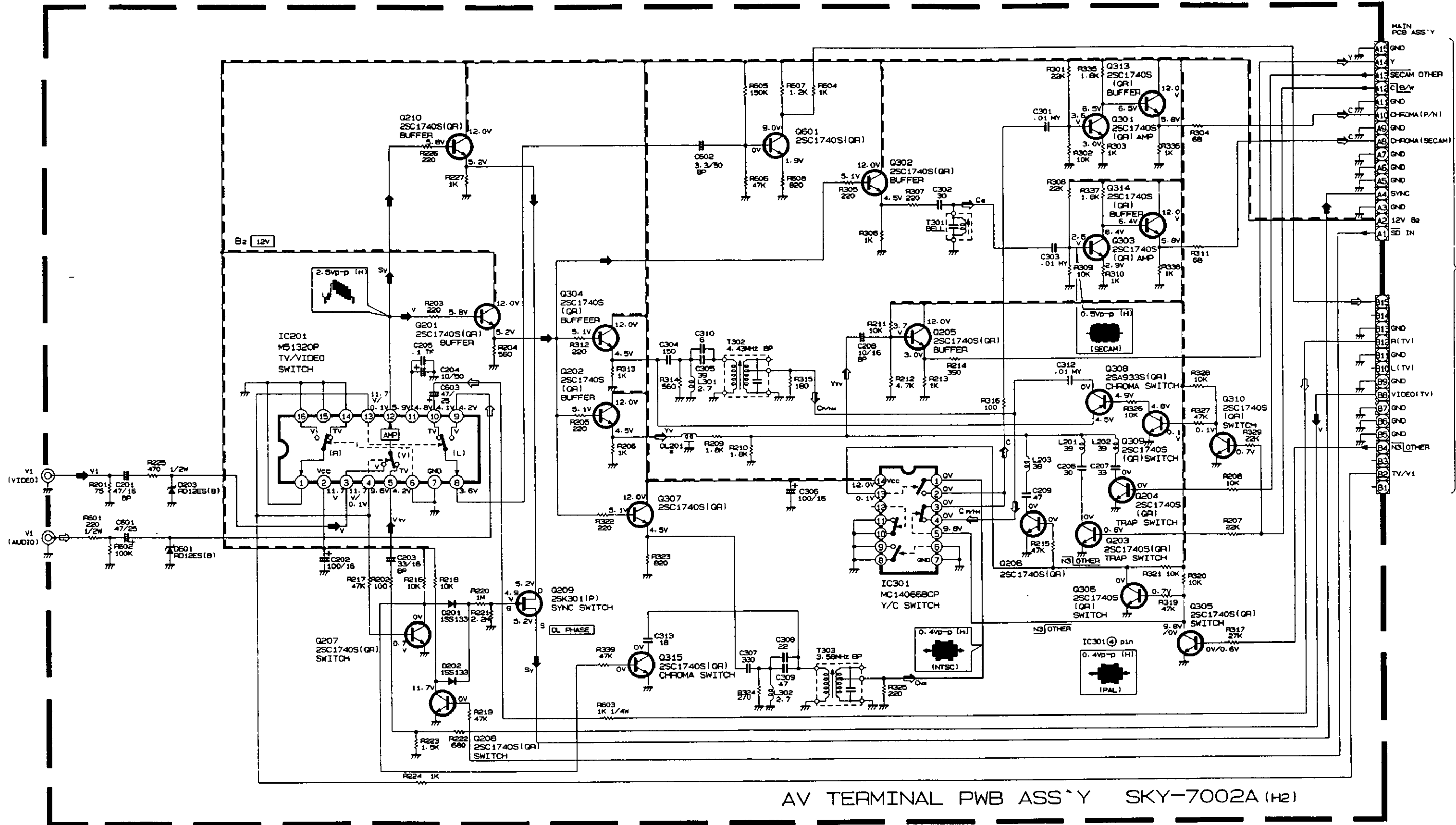



MAIN PWB, CONTROL PWB, LED PWB CIRCUIT DIAGRAMS

REFER TO THE FOLLOWING PWB PATTERN; MAIN PWB 2-17 page, CONTROL PWB 2-21 page LED PWB 2-21 page.

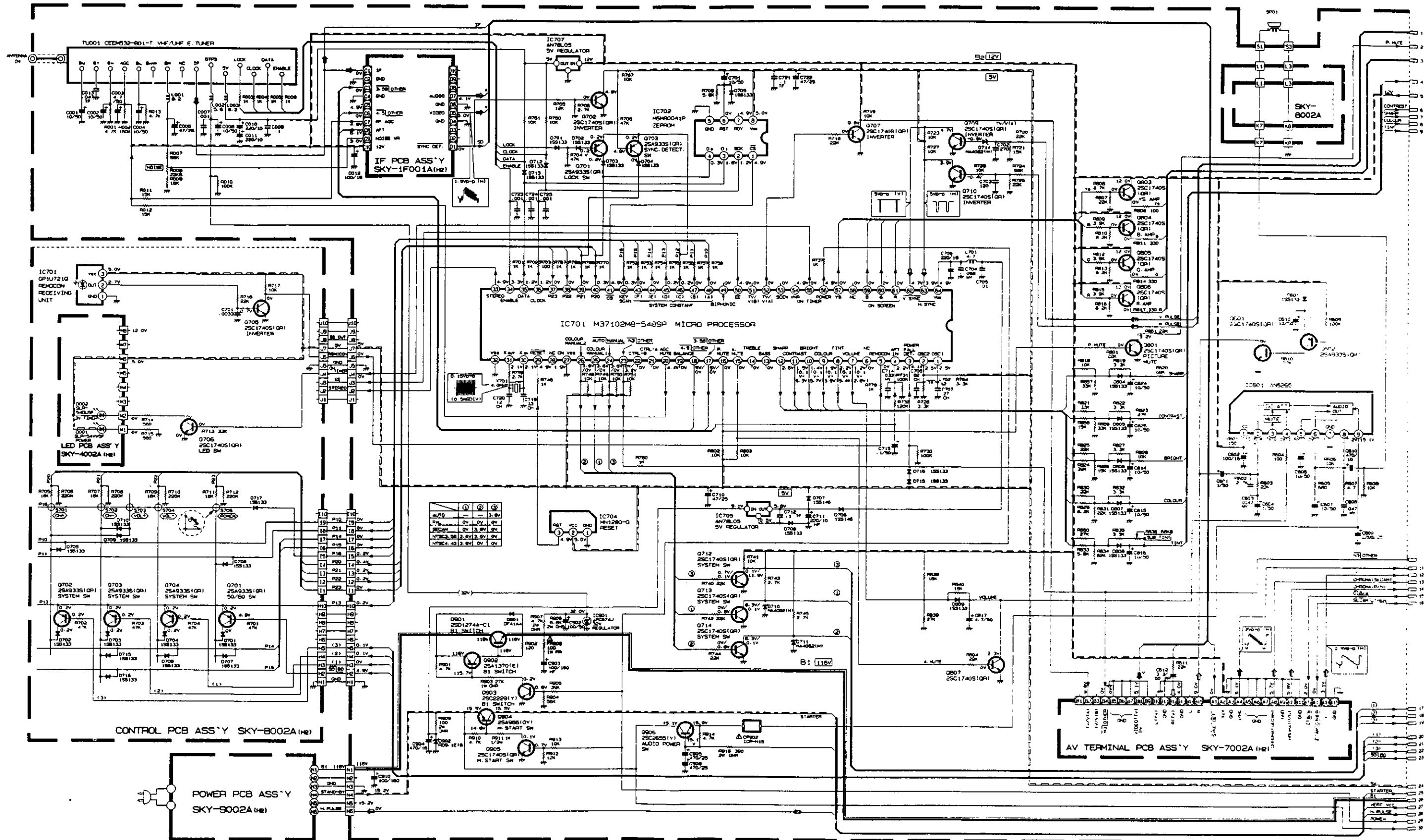

MAIN PWB, CRT SOCKET PWB CIRCUIT DIAGRAMS

REFER TO THE FOLLOWING PWB PATTERN; MAIN PWB 2-17 page CRT SOCKET PWB 2-19 page.

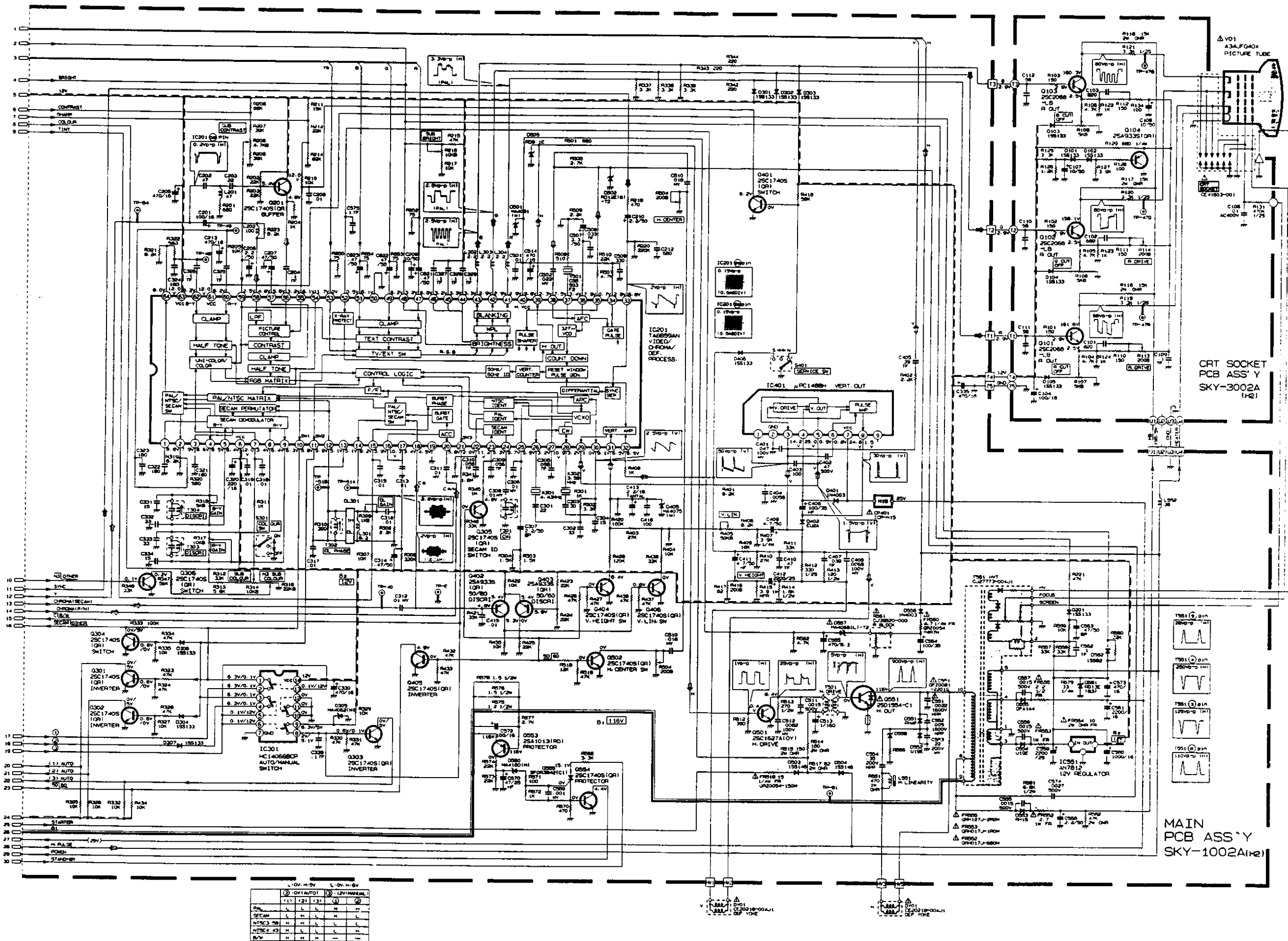

CRT SOCKET PCB ASS'Y SKY-3002A (H2)

MAIN PCB ASS'Y SKY-1002A(H2)

|         | OFF/AUTO | 12V/MANUAL |
|---------|----------|------------|
| PA      | L        | L          |
| SECAM   | L        | L          |
| NTSC 30 | L        | L          |
| NTSC 43 | L        | L          |
| 5V      | H        | H          |

POWER PWB CIRCUIT DIAGRAMS

REFER TO THE FOLLOWING PWB PATTERN; POWER PWB 2-22 page.

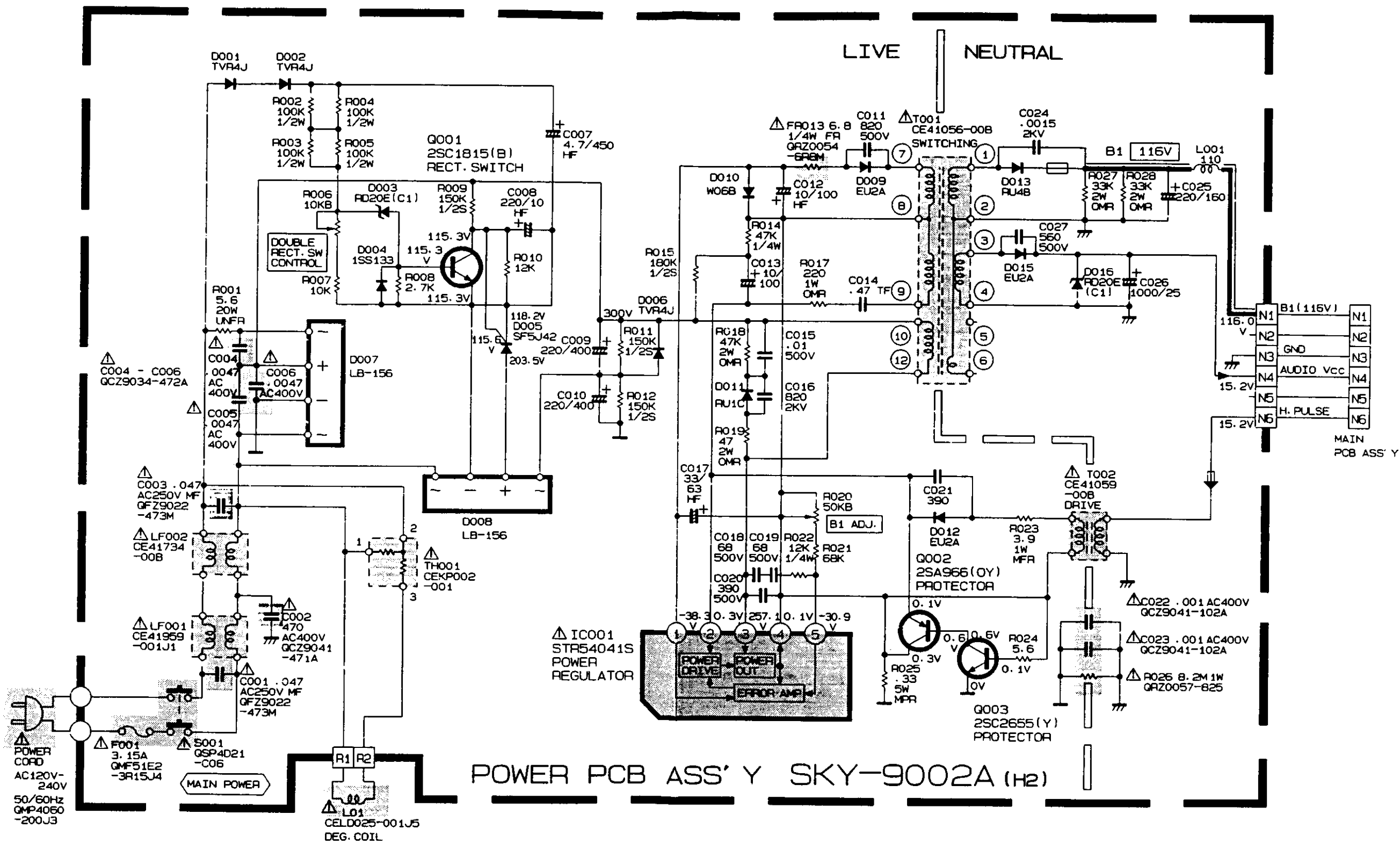

POWER PCB ASS'Y SKY-9002A (H2)

IF PWB CIRCUIT DIAGRAMS

REFER TO THE FOLLOWING PWB PATTERN; IF PWB 2-23 page.

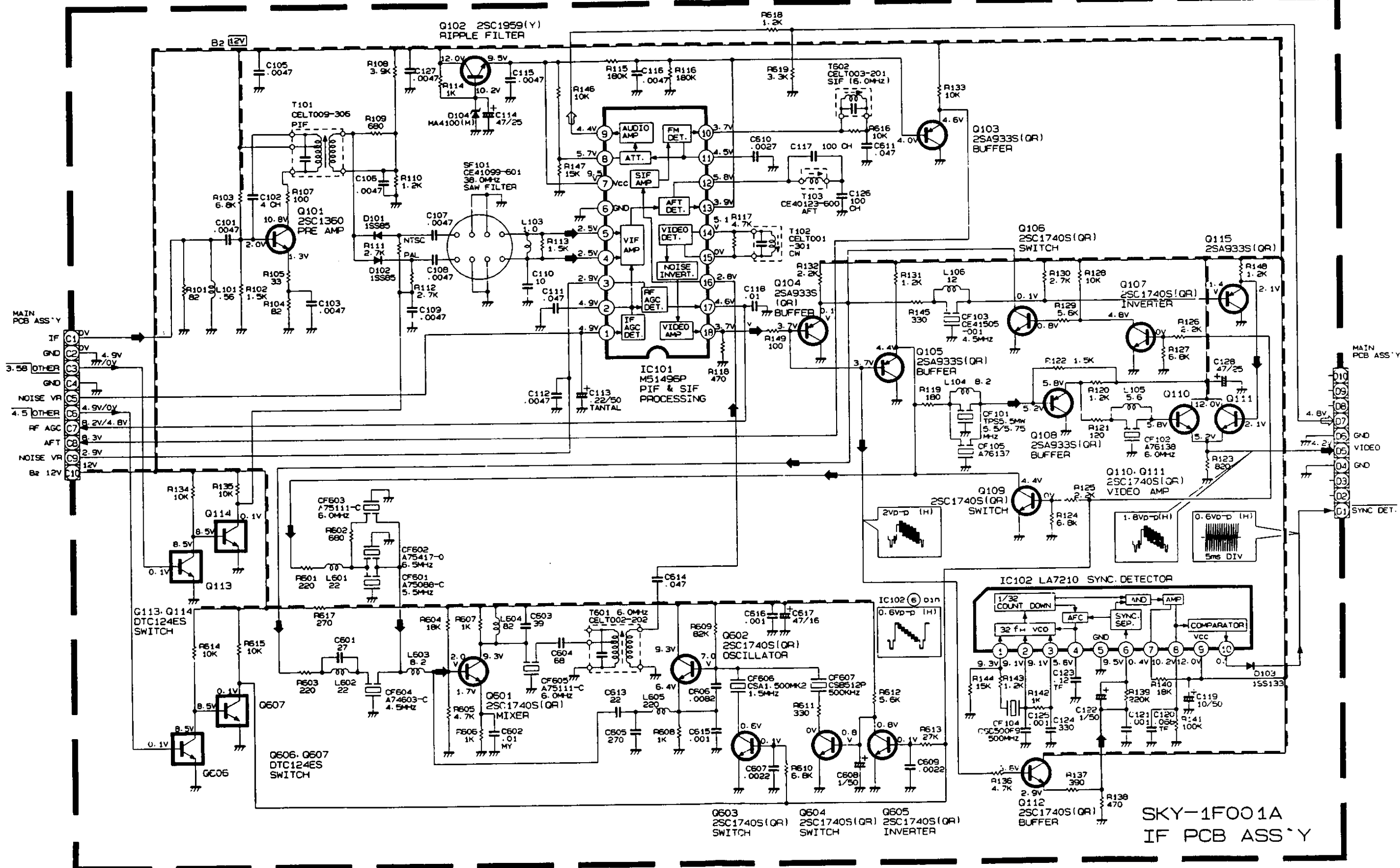

MAIN PWB PATTERN

(SKY-1002A)

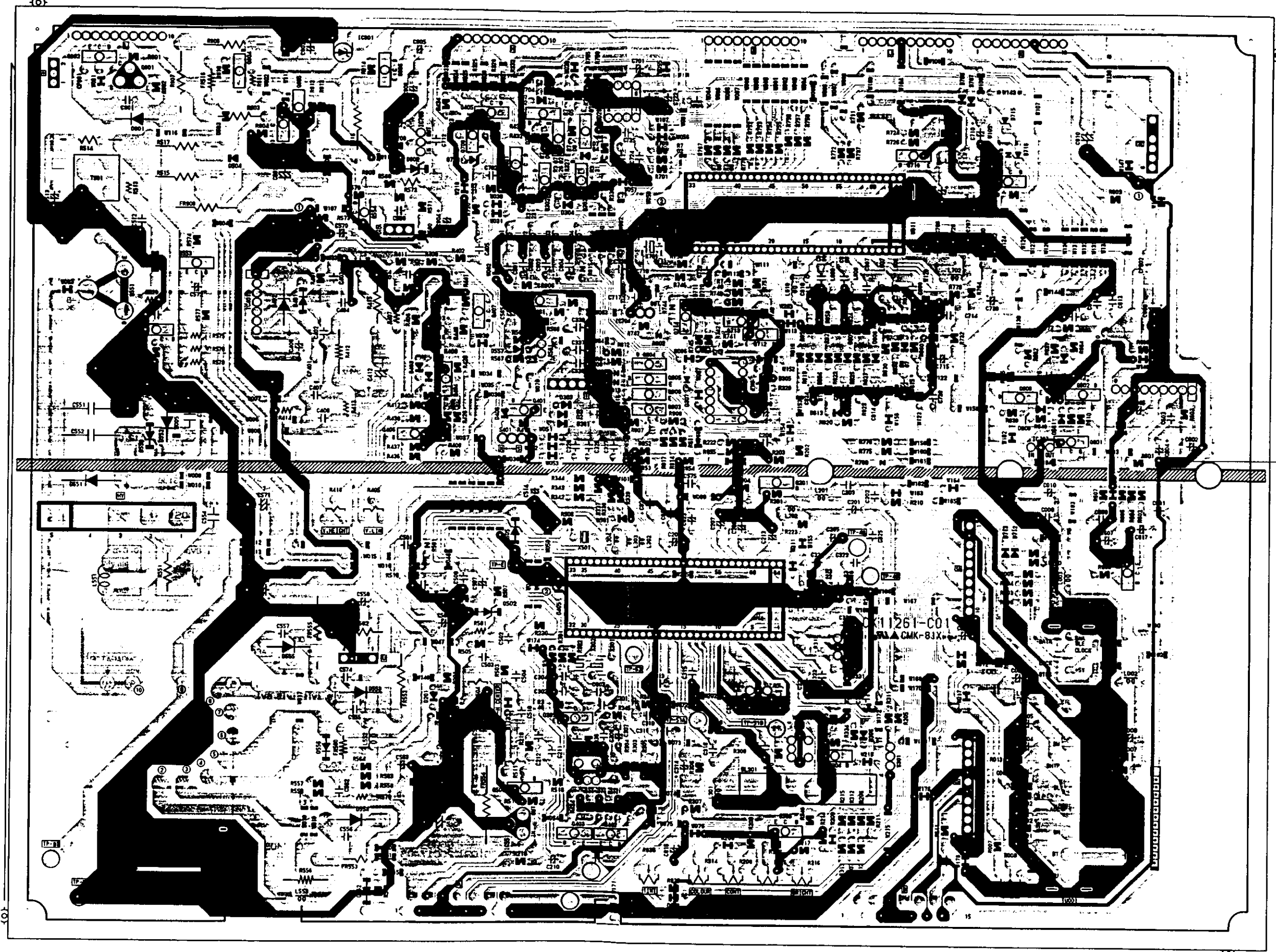

↑  
FRONT

CRT SOCKET PWB PATTERN

(SKY-3002A)

↑ TOP

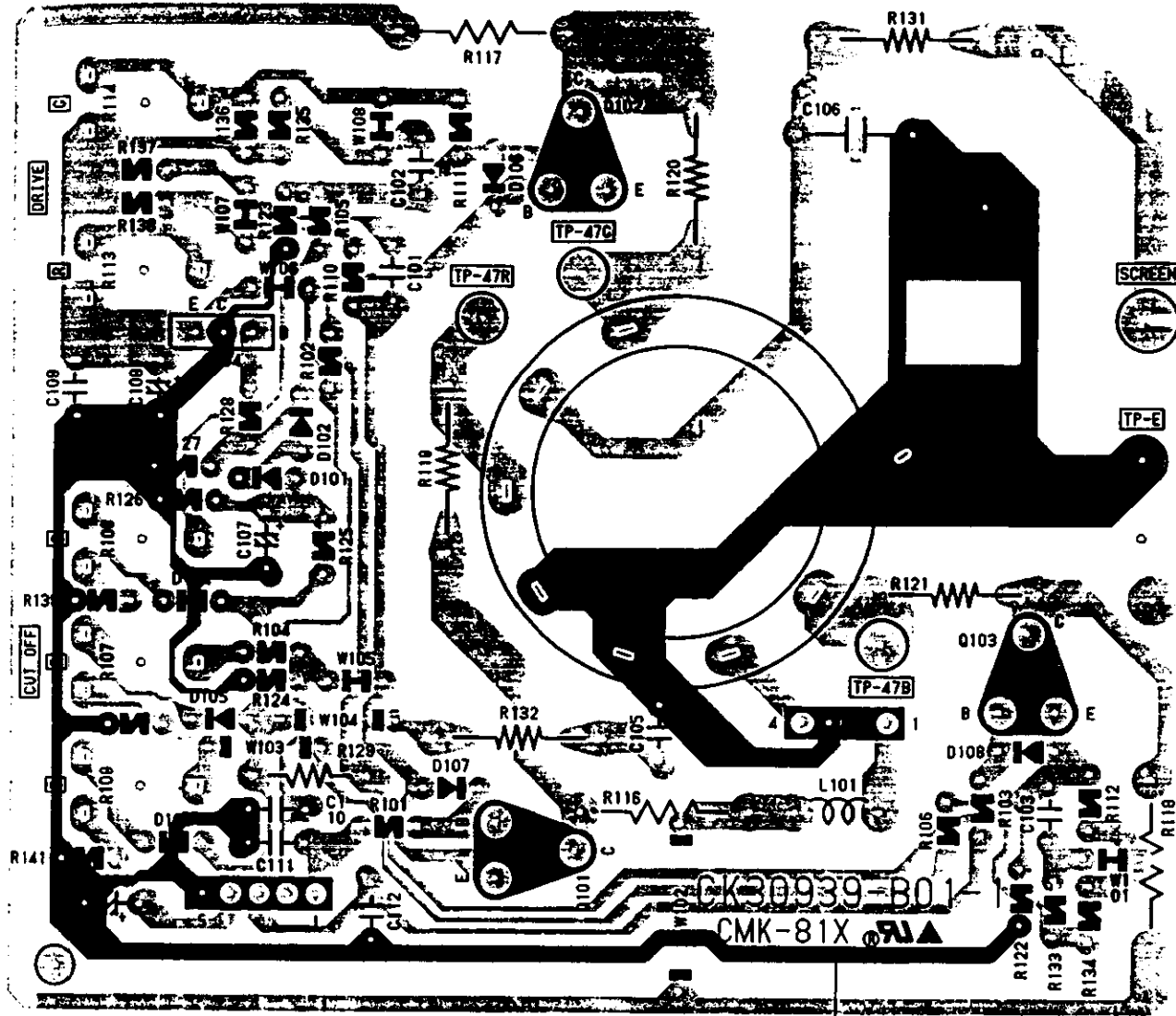

(77)

AV TERMINAL PWB PATTERN

(SKY-7002A)

↑ TOP

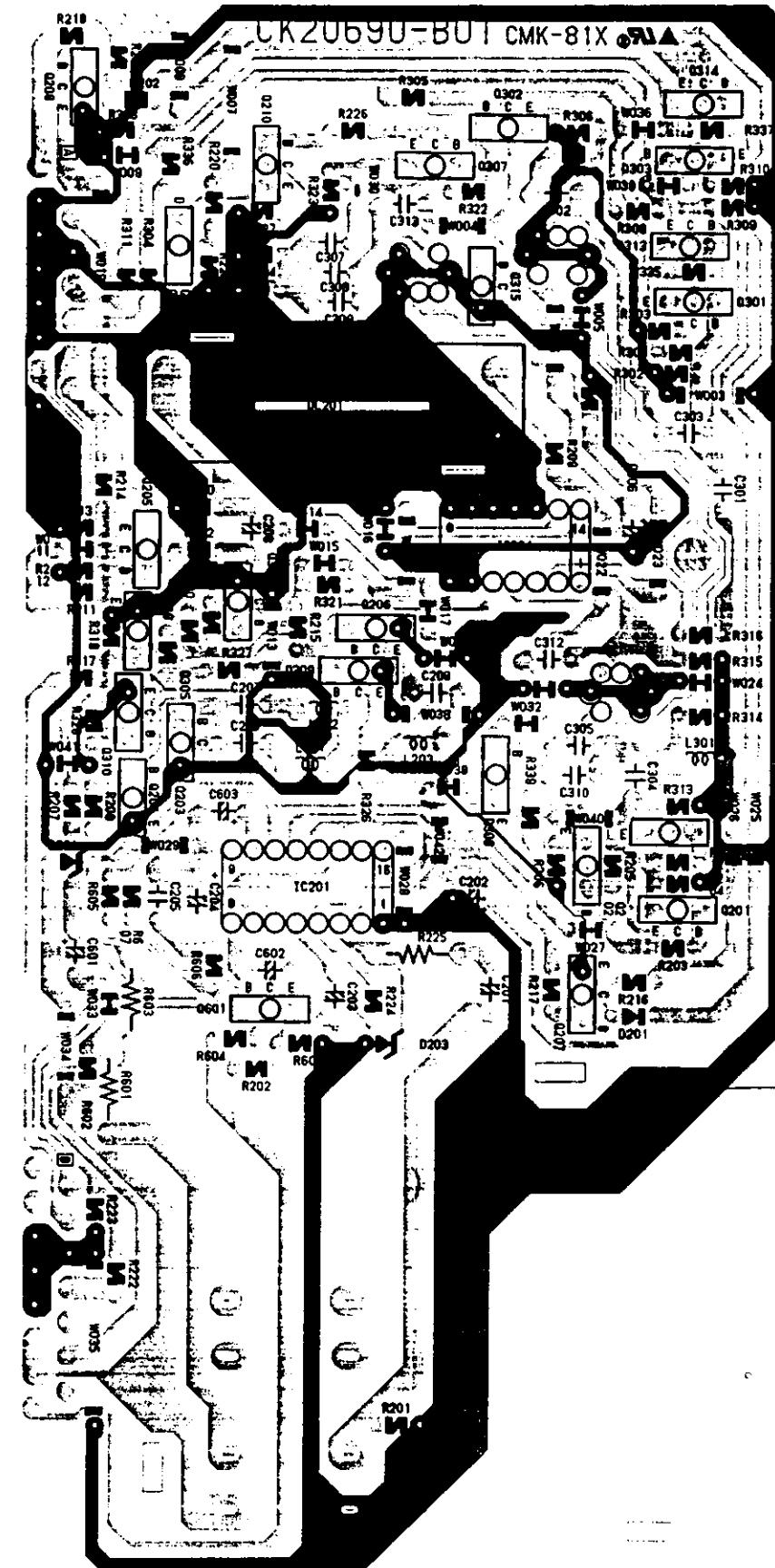

(77)



CONTROL & LED PWB PATTERN

(SKY-8002A) (SKY-4002A)

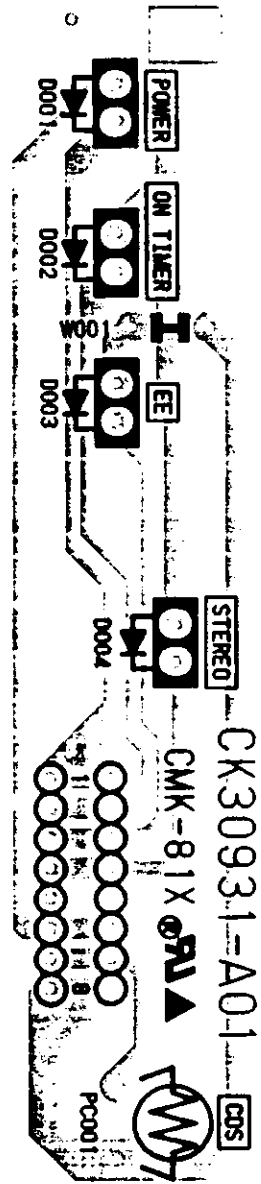
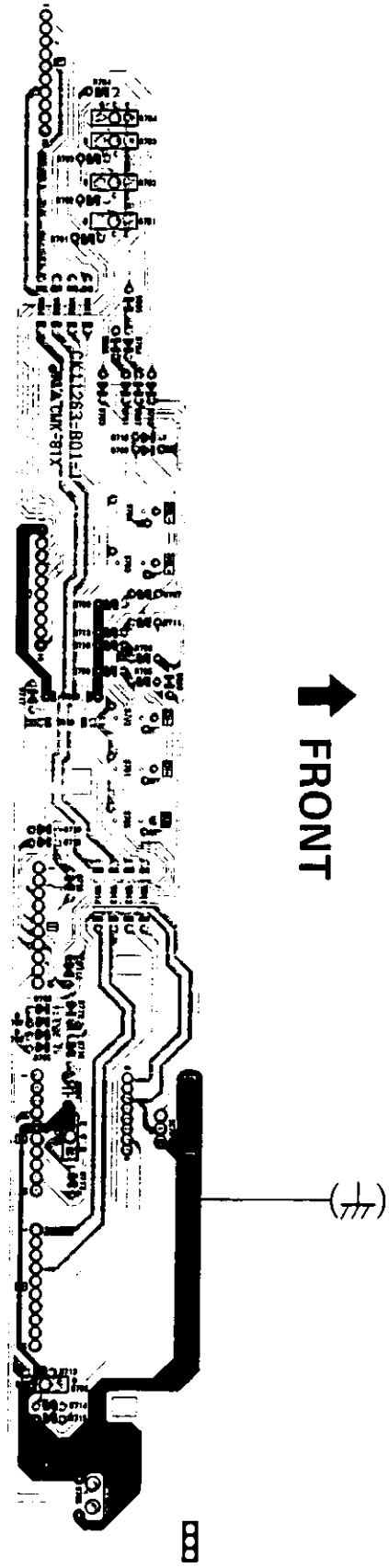

POWER PWB PATTERN

(SKY-9002A)

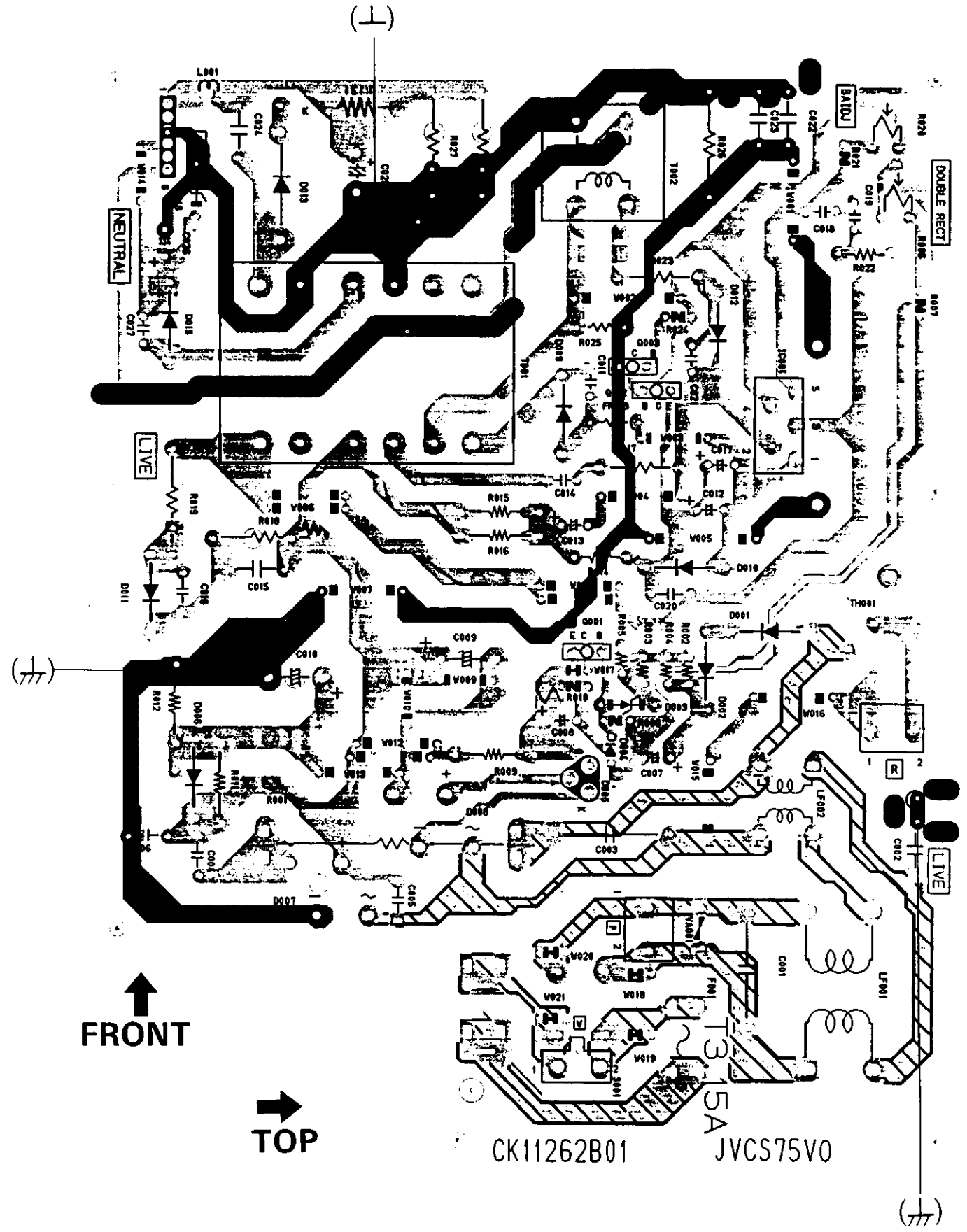

IF PWB PATTERN

(SKY-1F001A)

